

# YEARBOOK

OF THE

UNITED STATES  
DEPARTMENT OF  
AGRICULTURE

1919



**Agriculture is the foundation of  
Manufacture and Commerce**

WASHINGTON  
GOVERNMENT PRINTING OFFICE

1920

[ACT JANUARY 12, 1895, CHAP. 23, 28 STAT., 612.]

\* \* \* \* \*

[AN ACT Providing for the public printing and binding and the distribution of  
public documents.]

\* \* \* \* \*

Section 73, paragraph 2:

The Annual Report of the Secretary of Agriculture shall hereafter be submitted and printed in two parts, as follows: Part One, which shall contain purely business and executive matter which it is necessary for the Secretary to submit to the President and Congress; Part Two, which shall contain such reports from the different Bureaus and Divisions, and such papers prepared by their special agents, accompanied by suitable illustrations, as shall, in the opinion of the Secretary, be specially suited to interest and instruct the farmers of the country, and to include a general report of the operations of the Department for their information. There shall be printed of Part One, one thousand copies for the Senate, two thousand copies for the House, and three thousand copies for the Department of Agriculture; and of Part Two, one hundred and ten thousand copies for the use of the Senate, three hundred and sixty thousand copies for the use of the House of Representatives, and thirty thousand copies for the use of the Department of Agriculture, the illustrations for the same to be executed under the supervision of the Public Printer, in accordance with directions of the Joint Committee on Printing, said illustrations to be subject to the approval of the Secretary of Agriculture; and the title of each of the said parts shall be such as to show that such part is complete in itself.

# ORGANIZATION OF U. S. DEPARTMENT OF AGRICULTURE.

CORRECTED TO MARCH 1, 1920.

Secretary of Agriculture, EDWIN THOMAS MEREDITH.  
Assistant Secretary of Agriculture, JAMES R. RIGGS.  
Assistant to the Secretary, FLOYD R. HARRISON.  
Private Secretary to the Secretary, HARRISON F. FITTS.  
Solicitor, WILLIAM MARTIN WILLIAMS.  
Chief Clerk, R. M. REESE.  
Office of Farm Management, HENRY C. TAYLOR, *Chief*.  
Weather Bureau, CHARLES F. MARVIN, *Chief*.  
Bureau of Animal Industry, JOHN R. MOHLER, *Chief*.  
Bureau of Plant Industry, WM. A. TAYLOR, *Plant Physiologist and Pathologist and Chief*.  
Forest Service, HENRY S. GRAVES, *Forester and Chief*.  
Bureau of Chemistry, CARL L. ALSBERG, *Chemist and Chief*.  
Bureau of Soils, MILTON WHITNEY, *Soil Physicist and Chief*.  
Bureau of Entomology, L. O. HOWARD, *Entomologist and Chief*.  
Bureau of Biological Survey, EDWARD W. NELSON, *Biologist and Chief*.  
Division of Accounts and Disbursements, A. ZAPPONE, *Chief and Disbursing clerk*.  
Division of Publications—including Offices of Information, Exhibits, Motion Pictures, etc.—EDWY B. REID, *Chief*.  
Bureau of Crop Estimates, LEON M. ESTABROOK, *Statistician and Chief*.  
States Relations Service, A. C. TRUE, *Director*.  
Bureau of Public Roads, THOMAS H. MACDONALD, *Chief*.  
Bureau of Markets, GEORGE LIVINGSTON, *Chief*.  
Insecticide and Fungicide Board, J. K. HAYWOOD, *Chairman*.  
Federal Horticultural Board, C. L. MARLATT, *Chairman*.  
Librarian, CLARIBEL R. BARNETT.

## CONTENTS.

	Page.
Report of the Secretary of Agriculture.....	9
Prewar Crop Estimates in Germany. By Alonzo Englebert Taylor..	61
Progress in Eradicating Contagious Animal Diseases. By John R. Mohler.....	69
Community Tile Drainage Construction. By John R. Haswell.....	79
How to Use Market Stations. By G. B. Fiske.....	94
Atmospheric Nitrogen for Fertilizers. By R. O. E. Davis.....	115
Farm Practices in Growing Wheat: A Geographical Presentation. By J. H. Arnold and R. R. Spafford .....	123
Three Centuries of Tobacco. By George K. Holmes.....	151
The Open Road through the Nation's Forest. By John L. Cobbs, jr..	177
Influence of Depreciation of Exchange on Agricultural Production. By Alonzo Englebert Taylor.....	189
Practical Points in Hog-Cholera Control. By T. P. White.....	197
Marketing and Purchasing Demonstrations in the South. By Bradford Knapp.....	205
Electric Light and Power in the Farm Home. By A. M. Daniels.....	223
Federal Supervision of Live-Stock Markets. By Louis D. Hall.....	239
Cooperative Improvement of Citrus Varieties. By A. D. Shamel...	249
The Toll of Tuberculosis in Live Stock. By J. A. Kiernan and L. B. Ernest.....	277
The Reorganization of the Country School. By Alvin Dille.....	289
Common Sense in Poultry Keeping. By Rob R. Slocum.....	307
Why Produce Inspection Pays. By H. E. Kramer and G. B. Fiske..	319
Home Production of Lime by the Farmer. By C. C. Fletcher.....	335
What the Farmer Should Expect from the Seedsman. By Edgar Brown.....	343
Harnessing Heredity to Improve the Nation's Live Stock. By D. S. Burch.....	347
The Fight against the Pink Bollworm in the United States. By W. D. Hunter.....	355
Selling Purebred Stock to South America. By David Harrell and H. P. Morgan.....	369
The Farmers' Purchase Power, How Organized. By J. M. Mehl.....	381
Live-Stock Drought Relief Work in 1919. By George M. Rommel..	391
Live-Stock Conditions in Europe. By Turner Wright and George A. Bell.....	407
Securing a Dry Cellar. By George M. Warren.....	425
Trapping on the Farm. By Ned Dearborn.....	451
The Horse Power Problem on the Farm. By Oscar A. Juve.....	485
Appendix:	
Agricultural Colleges in the United States.....	497
Agricultural Experiment Stations.....	499
State Officials in Charge of Agriculture.....	500

## Appendix—Continued.

State Officers in Charge of Cooperative Agricultural Extension Work.....	Page. 500
Live-Stock Associations.....	502
Statistics of Grain Crops, 1919.....	509
Statistics of Crops Other than Grain Crops.....	568
Live Stock, 1919.....	644
Imports and Exports of Agricultural Products.....	682
Miscellaneous Agricultural Statistics.....	722
Index.....	757

## ILLUSTRATIONS.

Charts showing upward tendency of crop yields per acre.....	18-21
Eradication of contagious pleuropneumonia.....	70
Eradication of cattle scabies.....	71
Eradication of sheep scabies.....	72
Eradication of bovine tuberculosis in District of Columbia.....	73
Extent of cooperative tuberculosis-eradication work in the United States.....	74
Eradication of cattle ticks.....	74
Suppression of foot-and-mouth disease.....	75
Extent of hog-cholera losses.....	76
Two methods of ditching and land benefited by drainage.....	81
Trenching machine.....	82
Trenching machines and a drained spot.....	84
How drainage helps.....	93
Dealer's display of produce.....	94
Direct circulation of market news.....	100
Produce in freight terminal, Cleveland; transferring a shipment, New York; produce warehouse, Baltimore.....	101
Unloading produce, Pittsburgh; loading potatoes, Boston.....	102
Market centers in Norfolk, Va.....	104-105
Monthly average prices of leading crops, 1918-19.....	110
Maps 1 to 22, showing geographical distribution of various wheat-growing practices..	124-147
Typical report as made out by a farmer.....	125
Lister in operation—Kansas.....	131
Binder and header in operation.....	142
Combine in operation.....	143
Cradle in use.....	144
Cody Road in Shoshone National Forest, Wyoming.....	179
Difficult travel in the mountains of the West.....	181
Forest roads and a camp in the hills.....	183
Motoring along the "Top of the World" on the Rabbit Ears Road, Colorado.....	184
An open road, a road in the making, and a summer camp by the wayside.....	186
Travelers' registry booth; the "Fourth of July tree"; "fisherman's luck" on a National Forest.....	187
Burning, a safe way to destroy a diseased hog carcass.....	201
One method by which hog cholera may be spread.....	203
Milking by electricity.....	225
Portable utility motor.....	226
Motor-driven sewing machine.....	227
Vacuum cleaner.....	229
Drop shower and wall switch.....	231
Labor savers—motor-driven washing machine and separator.....	236

*Illustrations.*

7

	Page.
Electric iron.....	237
Trend of population and live stock, 1870 to 1919.....	241
In the stock yards.....	244
Waiting for a buyer.....	247
Best strain of the Washington Navel orange.....	252
Dry strain of the Washington Navel orange.....	253
Several strains of lemons from the same tree.....	254
A drone tree.....	255
A productive lemon tree.....	256
Orange variations on the same branch.....	257
Top-worked shade tree (lemon).....	258
Good results from top-working.....	259
Individual-tree numbering.....	262
Commercial performance record taking.....	263
Weighing, an essential step.....	264
Fruit-bearing orange bud wood.....	267
Fruit-bearing lemon bud wood.....	269
Strain characteristics revealed in the nursery trees.....	272
Trees produced from selected buds.....	273
Barn that housed an 82 per cent tuberculous herd.....	278
Diseased heifer from a tuberculous herd.....	280
Herd once diseased—now healthy.....	282
The old and the new in rural schools.....	290
Practical instruction in agriculture.....	296
Applied home economics.....	298
Going to school a pleasure.....	304
Mongrel flock.....	308
Flock of standardbred Barred Plymouth Rocks.....	309
A profitable hen.....	310
A less profitable hen.....	311
Interior of a movable poultry house.....	312
Suitable feeds for poultry.....	313
A happy family.....	314
Proper loading of produce in a car.....	322
Damage in transit.....	324
Damaged potatoes.....	325
Results of improper loading.....	326
Increase in produce inspections (chart).....	332
Location of inspection points (map).....	333
Small limestone crusher operated by farm tractor.....	335
Limestone pulverizer.....	336
Small stationary plant.....	337
Portable machine with tractor as power.....	338
Type of commercial pulverizer.....	340
First "Better Sires—Better Stock" emblem awarded.....	350
An unusual grade steer and a purebred yearling boar.....	351
Pink bollworm injury to top crop of cotton.....	358
Pink bollworm injury to bolls.....	361
Injury to partly opened boll.....	363
Cleaning cotton fields.....	366
Scenes in Brazil and Argentina.....	373
First-cross heifer and group of purebred bulls.....	378
Sheep arriving in Lake County, Minn., from drought area of Northwest.....	393
Ewes brought from Northwest in July being shipped to market in October.....	395
Range pasture used by cattle and sheep in Michigan.....	397
Drought area and area to which cattle and sheep were shipped (map).....	398
Native pasture and cut-over range in Michigan.....	400
Ranch scene in Texas and sheep herder just arrived from Northwest.....	402
Cut-over range in Minnesota.....	404
Normandy cow on farm near Caen, France.....	408
Normandy bull on farm near Cherbourg, France.....	409
First prize group of mares, Belgian horse show.....	412

	Page.
Cattle at work in southern Italy.....	415
Cattle at the Hull live-stock market.....	418
Cattle on the London markets.....	420
Four classes of ground and ground water conditions.....	426
Unsatisfactory cellar wall.....	427
Inside face of same wall.....	428
Shedding water from cellar walls.....	429
Conducting water along a cellar wall.....	430
How to waste roof water.....	431
Where roof water worked into the cellar.....	432
How to lead roof water away from the house.....	433
Looking across gutter.....	434
Air-filled space under cellar floors reduces dampness.....	435
Damp-proofing paint and plaster coat.....	436
Bituminous or asphaltic coating.....	437
Damp-proofing the outside of a cellar wall.....	438
How to drain a cellar site.....	439
Draining through house sewer—rarely advisable.....	440
Type of drain that should not be used.....	441
Sand and stone measuring frames or bottomless boxes.....	443
Faulty application of the membrane method of waterproofing.....	446
Correct application of the membrane method of waterproofing.....	448
Membrane waterproofing.....	449
Types of traps used for catching small rodents.....	453
Box trap for catching small animals uninjured.....	454
Details of construction of box trap.....	455
Shelter trap for catching cottontail rabbits.....	456
Traps for catching pocket gophers.....	457
Trap for disposing of vagrant cats humanely.....	458
Details of operation of cat trap.....	459
Great horned owl captured in a small jump trap placed on a post.....	460
Sieve trap for catching English sparrows.....	461
Funnel sparrow trap.....	462
Deadfall and wolf set.....	463
End-spring steel traps, for larger animals.....	464
Single and double spring jump traps.....	465
Diagram to illustrate the Bakken prairie-dog set for catching coyotes.....	469
Mole traps.....	471-473
Drying moleskins on a board.....	474
Box trap for muskrats in narrow streams.....	475
Cased mink skin on board stretcher.....	477
Fleshing beam.....	478
Stretchers for muskrat skins.....	479
Rabbit skin on wire stretcher.....	480
How horse labor is distributed through the year (three charts on folder).....	486
An operation in which tractor power may release horses for smaller power units.....	487
Half the work done by 2-horse teams.....	487
Power requirements vary.....	487
Size of team used and kind of farm.....	489
Size of team used and time of year.....	490
Number of horses per power unit (map).....	492
Working time and idle time of horses.....	493

# YEARBOOK OF THE UNITED STATES DEPARTMENT OF AGRICULTURE, 1919

## REPORT OF THE SECRETARY OF AGRICULTURE.

WASHINGTON, D. C., *November 15, 1919.*

SIR: America during the war helped to save Europe and to preserve civilization by making available to the Allies, through increased production and conservation, large supplies of foodstuffs. But for this contribution it is difficult to see how the Allies could have waged the war to a victorious conclusion. Lacking such support and with their own producing capacity seriously crippled, the German people experienced partial famine conditions; their health and vitality were greatly impaired; and the collapse of their military power was due in no small measure to the shortage of food.

The cessation of hostilities brought no immediate improvement in Europe. On the contrary, in some respects more adverse conditions developed. Revolution became the order of the day; the directing hand of government was removed; discipline was relaxed; the morale, particularly of the people of the Central Powers, was broken; idleness and unemployment prevailed; and in some sections anarchy reigned. It was obvious that Europe could not produce sufficient foods for herself. Her crops had been short for several years and it was scarcely probable that those for 1919 would be greater than the crops of the last year of the war. Quite as unsatisfactory was the live-stock situation. In nine of the western nations the number of cattle had declined more than 7,000,000, sheep 7,500,000, swine 24,500,000, and dairy cows several millions, with a greater proportionate reduction in the volume of products.

Food relief after the armistice was imperative not only for the peoples of the new small friendly nations but also of the enemy countries. It became the key to the whole



situation and to the establishment of a real peace. Europe had to be fed if order was to be restored and if European civilization, and, therefore, that of all the world, including our own, was to be preserved. America had again to assist in saving Europe and herself by supplying food, and that in great abundance. It was estimated that Europe would need to import at least 20,000,000 tons of bread grains alone, and that of this quantity 11,000,000 must come from the United States. It was obvious also that she would call for large imports of meats and fats, and that for months, until shipping expanded again, most of these must be obtained from the United States. This burden America was able to assume because of the achievements of her farmers. The full story can not be told; only the outcome can be suggested.

#### 1919 ACREAGES AND YIELDS.

The farmers of the Nation, in 1919, planted an acreage in leading cereals greater by 33,000,000 than the prewar annual average (1910-1914), which, it is estimated, will yield 635,000,000 bushels more than the prewar average, and increased the number of milch cows over 1914 by 2,700,000, of other cattle by 8,500,000, of swine by 16,700,000, and of horses and mules by 1,000,000, or a total of 28,900,000. The planting operations for the year began before the fighting ceased. The call was still for more wheat. The Department suggested a maximum fall acreage of 47,206,000 acres, an increase of 12 per cent over 1918. There was actually planted 49,261,000, the largest acreage in the Nation's history, 6,960,000 acres more than in 1918 and 15,608,000 more than the five-year average, 1910-1914. The spring-wheat acreage was 22,593,000, while the winter and spring plantings combined amounted to 71,854,000 acres, or 7,200,000 more than the preceding record and 19,400,000 more than the prewar average. It is estimated that the yield will exceed that of 1918 by 1,000,000 bushels

and will be the Nation's second record wheat crop. The estimated corn crop of 2,910,000,000 bushels will be 300,000,000 greater than that of 1918 and only slightly less than the high yields of 1915 and 1917.

If the fighting had continued and the season had been favorable, there is little question that the farmers of the country would have planted an aggregate crop acreage during the winter and spring greater than that for any preceding year in the Nation's history.

Forecasts of meat production for 1919, from partial reports of slaughtering, indicate that the record figure of last year—20,250,000,000 pounds—will be exceeded. The total will probably reach 21,000,000,000 pounds, as follows: Pork, 12,900,000,000 pounds, compared with 11,248,000,000 in 1918 and 8,769,000,000 in 1914; beef, 7,500,000,000 as against 8,500,000,000 in 1918 and 6,079,000,000 in 1914; and mutton 600,000,000 pounds as against 537,000,000 in 1918 and 739,000,000 in 1914.

A rough estimate, based upon the number of milch cows and the census average of milk production per cow, indicates that the number of gallons of milk produced in 1919 will aggregate 8,495,000,000, or 57,000,000 more than in 1918 and 1,029,000,000 more than the average for 1910-1914. The figures for poultry and egg production have not been accurately ascertained, but it is roughly estimated, upon the basis of reported increases from one census to another, that egg production in 1919 will aggregate 1,957,000,000 dozen, as against 1,921,000,000 in 1918 and 1,774,000,000 in 1914, and that the number of poultry raised on farms will approximate 600,000,000.

#### EXPORTS.

The exports of foodstuffs, enormous during the war, rose greatly between the armistice and midsummer. The annual average exports of important cereals for the five years preceding the war were 162,000,000 bushels. They rose to 517,000,000 in 1915 and aggregated 448,000,000 in 1919. Dairy products, of which 25,000,000 pounds were exported

on the average during the five-year period before the war, increased in volume to 102,400,000 pounds in 1915, 217,500,000 in 1916, 352,000,000 in 1917, 592,000,000 in 1918, and 781,000,000 in 1919; while the exports of meat and meat products were 1,291,000,000 pounds for the five-year average before the war, 1,500,000,000 in 1915, 1,800,000,000 in 1916, 2,300,000,000 in 1918, and 3,300,000,000 in 1919.

The following tables may facilitate the examination of these essential facts:

*Acreage of crops in the United States.*

[Figures refer to planted acreage for winter wheat and rye.]

Crop. <sup>1</sup>	1919 (unrevised estimate, October, 1919).	1918 (subject to revision). <sup>1</sup>	1917	1916	1915	1914	Annual average, 1910-1914.
<b>CEREALS.</b>							
Corn.....	102,977,000	107,494,000	116,730,000	105,296,000	106,197,000	103,435,000	105,240,000
Wheat.....	71,854,000	64,707,000	58,366,000	56,810,000	61,173,000	54,661,000	52,452,000
Oats.....	42,169,000	44,400,000	43,553,000	41,527,000	40,996,000	38,442,000	38,014,000
Barley.....	8,899,000	9,679,000	8,933,000	7,757,000	7,148,000	7,565,000	7,593,000
Rye.....	6,820,000	6,708,000	4,480,000	3,474,000	3,153,000	2,733,000	2,562,000
Buckwheat.	943,000	1,040,000	924,000	828,000	769,000	792,000	826,000
Rice.....	1,091,300	1,112,770	980,900	869,000	802,600	694,000	733,000
Kafirs.....	5,183,000	5,619,000	5,153,000	3,944,000	4,153,000	.....	.....
Total.....	239,936,300	240,759,770	239,119,900	220,505,000	224,391,600	<sup>2</sup> 208,322,000	<sup>2</sup> 207,420,000
<b>VEGETA- BLES.</b>							
Potatoes....	4,003,000	4,210,000	4,384,000	3,565,000	3,734,000	3,711,000	3,686,000
Sweet pota- toes.....	1,023,000	922,000	919,000	774,000	731,000	603,000	611,000
Total.....	5,026,000	5,132,000	5,303,000	4,339,000	4,465,000	4,314,000	4,297,000
Tobacco....	1,774,300	1,549,000	1,518,000	1,413,000	1,369,900	1,224,000	1,209,000
Cotton.....	32,390,000	35,890,000	33,841,000	34,985,000	31,412,000	36,832,000	35,330,000
Grand to- Total.....	279,126,600	283,330,770	279,781,900	261,242,000	261,638,500	<sup>2</sup> 250,692,000	<sup>2</sup> 248,256,000

<sup>1</sup> For revised figures, see tables in Appendix.

<sup>2</sup> Excluding grain sorghums.

Production in the United States.

[The figures are in round thousands, i. e., 000 omitted.]

Crop.	1919 (unre- vised estimate Novem- ber, 1919).	1918 (subject to re- vision).	1917	1916	1915	1914	Annual average, 1910- 1914.
CEREALS.							
Corn.....bushels..	2,910,250	2,582,814	3,065,233	2,566,927	2,994,793	2,672,804	2,732,457
Wheat.....do....	918,471	917,100	636,655	636,318	1,025,801	891,017	728,225
Oats.....do....	1,219,521	1,538,359	1,592,740	1,251,837	1,549,030	1,141,060	1,157,961
Barley.....do....	198,298	256,375	211,759	182,309	228,851	194,953	186,208
Rye.....do....	84,552	90,183	62,933	48,862	54,050	42,779	37,568
Buckwheat.....do....	20,120	17,182	16,022	11,662	15,056	16,881	17,022
Rice.....do....	44,261	40,424	34,739	40,861	28,947	23,649	24,378
Kafirs.....do....	123,343	66,396	61,409	53,858	114,460	.....	.....
Total.....do....	5,518,816	5,508,833	5,681,490	4,792,634	6,010,988	14,983,143	14,883,819
VEGETABLES.							
Potatoes.....bushels..	352,025	400,106	442,108	286,953	359,721	409,921	360,772
Sweet potatoes.....do....	102,946	86,334	83,822	70,955	75,639	56,574	57,117
B e a n s (commercial), bushels.....	12,690	17,437	16,045	10,715	10,321	11,585	.....
Onions, commercial crop, bushels.....	10,784	13,396	12,376	8,562	7,664	( <sup>2</sup> )	.....
C a b b a g e (commercial), tons.....	388	516	475	255	671	( <sup>2</sup> )	.....
FRUITS.							
Peaches.....bushels..	51,327	34,133	45,066	37,505	64,097	54,109	43,752
Pears.....do....	13,628	10,342	13,281	11,874	11,216	12,086	11,184
Apples.....do....	144,429	169,911	163,117	204,582	76,670	253,200	197,898
Cranberries (3 States), barrels.....	546	343	249	471	441	644	.....
MISCELLANEOUS.							
Flaxseed.....bushels..	9,450	14,657	9,164	14,296	14,030	13,749	18,353
Sugar beets.....tons..	7,298	5,890	5,980	6,228	6,511	5,585	5,391
Tobacco.....pounds..	1,316,553	1,340,019	1,249,276	1,153,278	1,062,237	1,034,679	991,958
All hay.....tons..	103,544	90,443	98,439	110,992	107,263	88,686	81,640
Cotton.....bales..	10,696	12,041	11,302	11,450	11,192	16,135	14,259
Sorghum sirup...gallons..	33,668	29,224	37,472	13,668	.....	.....	.....
Peanuts.....bushels..	44,966	54,434	52,505	35,324	.....	.....	.....
Broom corn (5 States), tons.....	51	58	57	39	.....	.....	.....
Clover seed.....bushels..	967	1,102	1,488	1,706	.....	.....	.....

<sup>1</sup> Excludes grain sorghums.

<sup>2</sup> No estimate.

14 *Yearbook of the Department of Agriculture, 1919.*

*Number of live stock on farms on January 1, 1910-1919.*

[The figures are in round thousands, i. e., 000 omitted.]

Kind.	1919	1918	1917	1916	1915	1914	Annual average, 1910-1914.
Horses.....	21,534	21,555	21,210	21,159	21,195	20,962	20,430
Mules.....	4,925	4,873	4,723	4,593	4,479	4,449	4,346
Milch cows.....	23,467	23,310	22,894	22,108	21,262	20,737	20,676
Other cattle.....	44,399	44,112	41,689	39,812	37,067	35,855	38,000
Sheep.....	49,863	48,603	47,616	48,625	49,956	49,719	51,929
Swine.....	75,587	70,978	67,503	67,766	64,618	58,933	61,865

*Estimated production of meat, milk, and wool.*

[The figures are in round thousands, i. e., 000 omitted.]

Product.	1919	1918	1917	1916	1914	1909
Beef <sup>1</sup> .....pounds..	7,500,000	8,465,000	7,384,007	6,670,938	6,078,908	8,138,000
Pork <sup>1</sup> .....do....	12,868,000	11,248,000	8,450,148	10,587,765	8,768,532	8,199,000
Mutton and goat <sup>1</sup> .....do....	637,000	537,000	491,205	633,969	739,401	615,000
Total.....do....	21,005,000	20,250,000	16,325,360	17,892,672	15,586,841	16,952,000
Milk <sup>2</sup> .....gallons..	8,495,000	8,438,000	8,288,000	8,003,000	7,507,000	7,466,466
Wool (including pulled wool), pounds.....	308,459	298,870	281,892	288,490	290,192	289,420
Eggs produced <sup>3</sup> .....dozen..	1,957,000	1,921,000	1,884,000	1,848,000	1,774,000	<sup>4</sup> 1,591,000
Poultry raised <sup>3</sup> .....number..	600,000	589,000	578,000	567,000	544,000	<sup>4</sup> 488,000

<sup>1</sup> Estimated for 1914-1918 by the Bureau of Animal Industry. Figures for meat production for 1919 are tentative estimates based upon 1918 production and a comparison of slaughter under Federal inspection for 6 months of 1919 with the corresponding 6 months in 1918.

<sup>2</sup> Estimated for 1914-1919 by assuming 362 gallons as the average yearly production of milk per cow. This average is given in the census for 1909.

<sup>3</sup> Estimated by assuming a constant increase since 1910.

<sup>4</sup> Annual averages for 1910-1914: Eggs, 1,695,000,000 dozen; poultry, 522,000,000.

*Exports of live stock from the United States.*

[Bureau of Foreign and Domestic Commerce, United States Department of Commerce.]

Kind.	Annual average, 1910-1914.	Fiscal year ending June 30—					Three months, July to September, 1919.
		1915	1916	1917	1918	1919	
	<i>Number.</i>	<i>Number.</i>	<i>Number.</i>	<i>Number.</i>	<i>Number.</i>	<i>Number.</i>	<i>Number.</i>
Horses.....	28,073	289,340	357,553	278,674	84,765	22,776	5,971
Mules.....	5,125	65,788	111,915	136,689	28,879	4,883	906
Cattle.....	88,225	5,484	21,287	13,387	18,213	18,376	20,803
Sheep.....	522,505	182,278	231,535	58,811	7,959	152,000	14,186
Swine.....	11,191	7,799	22,048	21,926	9,280	10,122	2,285

*Exports of domestic foodstuffs and cotton from the United States.*

[Reports of Bureau of Foreign and Domestic Commerce, United States Department of Commerce.]

Article exported.	Annual average, 1910-1914.	Year ending June 30—						Three months, July to September, 1919.
		1915	1916	1917	1918	1919		
						Amount.	Per cent of 1910-1914.	
Wheat.....bushels..	56,913,228	259,642,533	173,274,015	149,831,427	34,118,853	178,582,673	313.8	35,651,158
Wheat flour.....barrels..	10,678,635	16,182,765	15,520,669	11,942,778	21,880,151	24,190,092	226.5	5,132,968
Oats.....bushels..	8,304,203	96,809,551	95,918,884	88,944,401	105,881,233	96,360,974	1,160.4	14,273,916
Rye.....do....	854,765	12,544,888	14,532,437	13,260,015	12,065,922	27,540,188	3,222.3	3,691,246
Barley.....do....	7,895,521	26,754,522	27,473,160	16,381,077	26,408,978	20,457,781	259.1	16,643,135
Corn.....do....	39,809,690	48,786,291	38,217,012	64,720,842	40,997,827	16,687,538	41.9	2,613,519
Total 5 cereals, including flour.....do....	161,831,264	517,360,227	419,258,518	386,880,263	317,933,492	448,484,568	.....	95,971,330
Sugar.....pounds..	70,976,908	549,007,411	1,630,150,863	1,248,908,286	576,415,850	1,115,865,524	1,572.2	333,452,731
Dairy products:								
Butter.....pounds..	4,277,955	9,850,704	13,487,481	26,835,092	17,735,966	33,739,960	788.7	4,416,051
Cheese.....do....	4,915,502	55,362,917	44,394,301	66,050,013	44,330,978	18,794,853	382.4	2,465,335
Milk, condensed.....do....	15,773,900	37,235,627	159,577,620	259,141,231	529,750,032	728,740,509	4,619.9	192,881,959
Total dairy products.....do....	24,967,357	102,449,248	217,459,402	352,026,336	591,816,976	781,275,322	.....	199,763,345

*Report of the Secretary.*

Exports of domestic foodstuffs and cotton from the United States—Continued.

Article exported.	Annual average, 1910-1914.	Year ending June 30—						Three months, July to September, 1919.
		1915	1916	1917	1918	1919		
						Amount.	Per cent of 1910-1914.	
<b>Meat and meat products:</b>								
Canned beef.....pounds..	9,392,122	75,243,261	50,803,765	67,536,125	97,366,983	108,489,472	1,155.1	9,500,174
Fresh beef.....do....	29,452,302	170,440,934	231,214,000	197,177,101	370,057,514	332,205,176	1,127.9	24,041,841
Pickled beef.....do....	32,893,172	31,874,743	38,114,682	58,053,667	54,867,310	45,067,861	137.0	9,338,564
Oleo oil.....do....	280,224,505	80,481,946	102,645,914	67,110,111	56,648,102	59,092,322	21.1	18,626,949
Bacon.....do....	182,474,092	346,718,227	579,808,786	667,151,972	815,319,424	1,239,540,973	679.3	259,009,482
Hams and shoulders.....do....	166,813,134	203,701,114	282,208,611	266,656,581	419,571,869	667,848,019	400.4	105,809,800
Pickled pork.....do....	48,274,929	45,655,574	63,460,713	46,992,721	33,221,502	31,504,497	65.3	7,362,746
Lard.....do....	474,354,914	475,531,908	427,011,338	444,769,540	392,498,435	725,577,868	153.0	154,092,726
Lard compounds.....do....	67,318,857	69,980,614	52,843,311	56,359,493	31,278,382	131,750,503	195.7	19,030,447
Total meat and meat products.....do....	1,291,198,027	1,499,628,321	1,828,111,120	1,871,807,311	2,270,829,521	3,341,076,691	.....	606,812,729
Cotton.....do....	4,419,802,157	4,403,578,499	3,084,070,125	3,088,080,786	2,320,511,665	2,733,683,125	61.9	632,449,973

## VALUES.

On the basis of prices that have recently prevailed, the total value of all crops produced in 1919 is \$15,873,000,000, compared with \$14,222,000,000 for 1918; \$13,479,000,000 for 1917; \$9,054,000,000 for 1916; \$6,112,000,000 for 1914; and \$5,827,000,000 for the five-year average, 1910-1914. These values represent gross production and not net returns to the producer. The value of live stock on farms in 1919 was \$8,830,000,000, compared with \$8,284,000,000 in 1918; \$6,736,000,000 in 1917; \$6,021,000,000 in 1916; \$5,890,000,000 in 1914; and \$5,318,000,000 for the five-year average, 1910-1914.

This increased financial showing, it is again necessary to emphasize, does not mean that the Nation is better off to that extent or that its real wealth has advanced in that proportion. Considering merely the domestic relations, the true state is indicated rather in terms of real commodities, comparative statements of which are given in the foregoing tables. The increased values, however, do reveal that the monetary returns to the farmers have increased proportionately with those of other groups of producers in the Nation and that their purchasing power has kept pace in the rising scale of prices.

## PROGRESS OF AMERICAN AGRICULTURE.

The results of agricultural operations during the war furnish guaranty of the ability of the present farm population of the country, with the area now in farms and in the existing state of agricultural science and practice, to meet the Nation's necessities for the near future if the requisite incentives are furnished. But there are reasons for further optimism. As has been repeatedly pointed out, we still have a large area of untouched tillable land. This is somewhat generally understood, but it is not so well known that, as the result of improved processes and better practices in all sections, there has been an upward tendency in the acre yields. As a matter of fact, the view seems more frequently to be expressed



that in this respect American agriculture has deteriorated. The facts disprove this, and in no part of the Union more strikingly than in the older regions, such as the New England and North Atlantic States.

Crop yields per acre in the United States show an upward tendency during the period for which we have reliable comparable statistics. The average rate of increase for the past 25 years has been about one-half of 1 per cent a year. This gain is not readily observed from one year to another, owing to the wide yearly fluctuations in yield. But when averages for a series of years are obtained, the effect of the seasonal variations is largely neutralized and the general trend is clear. The upward tendency is shown graphically in the following charts:

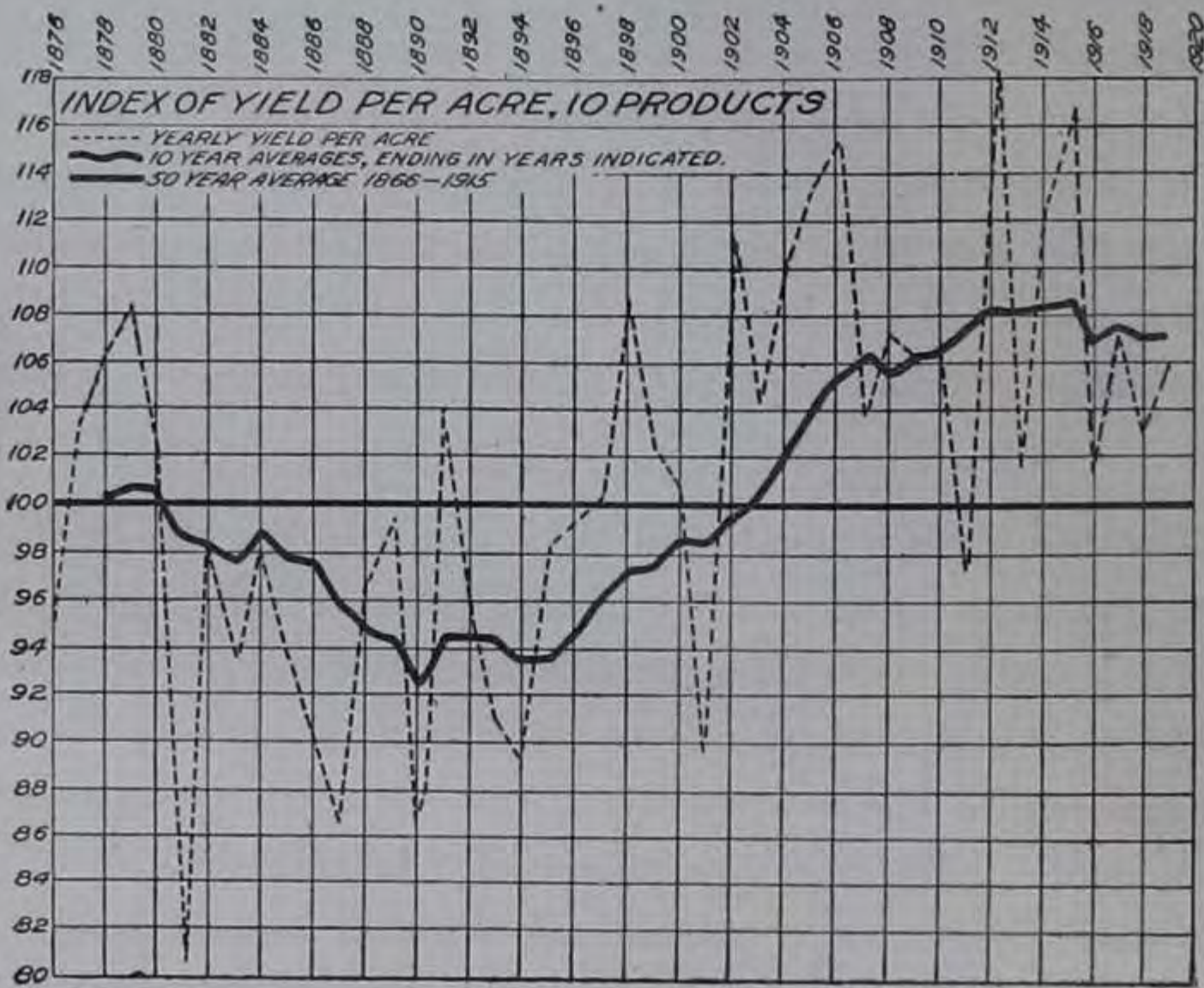

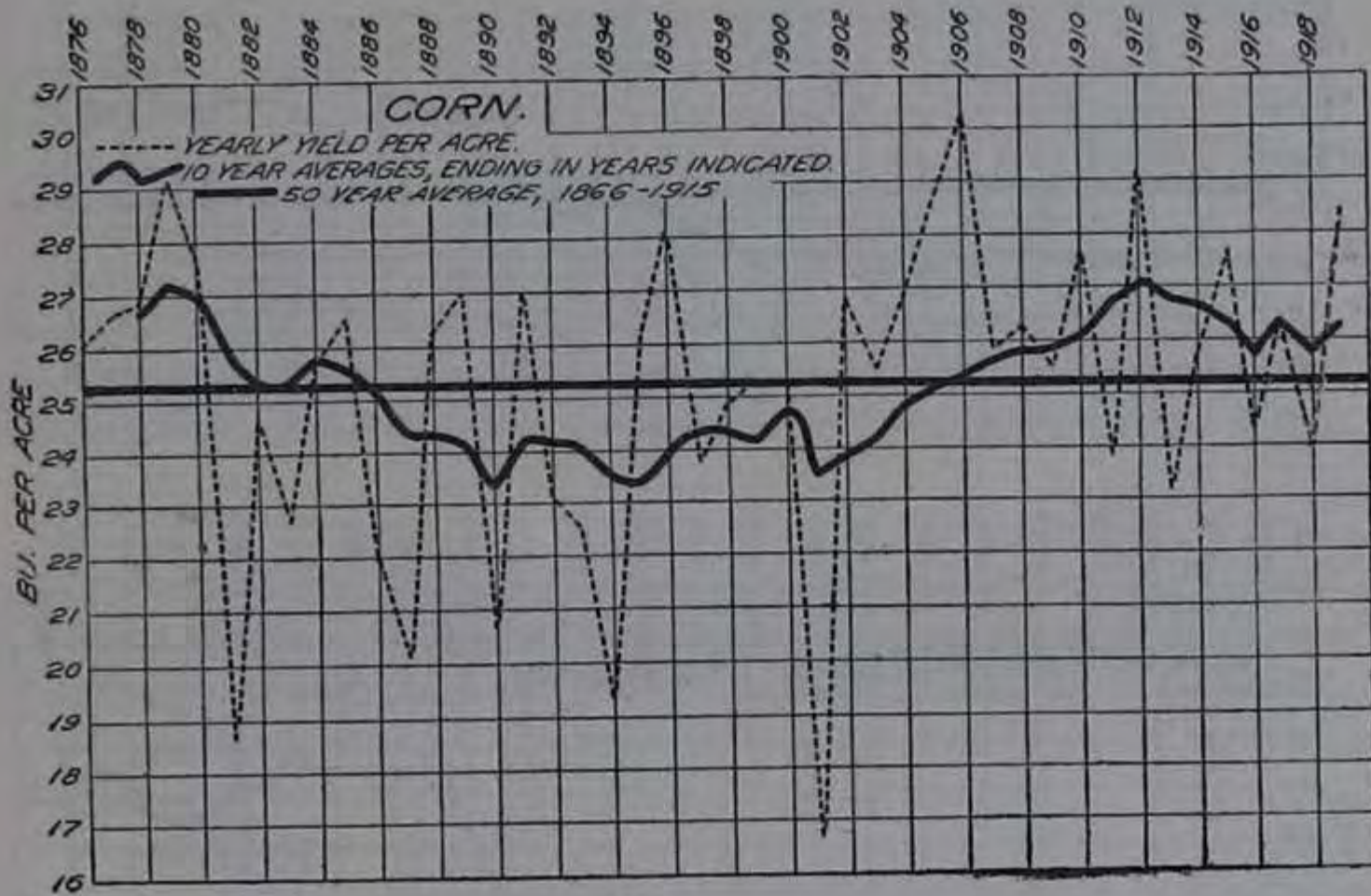
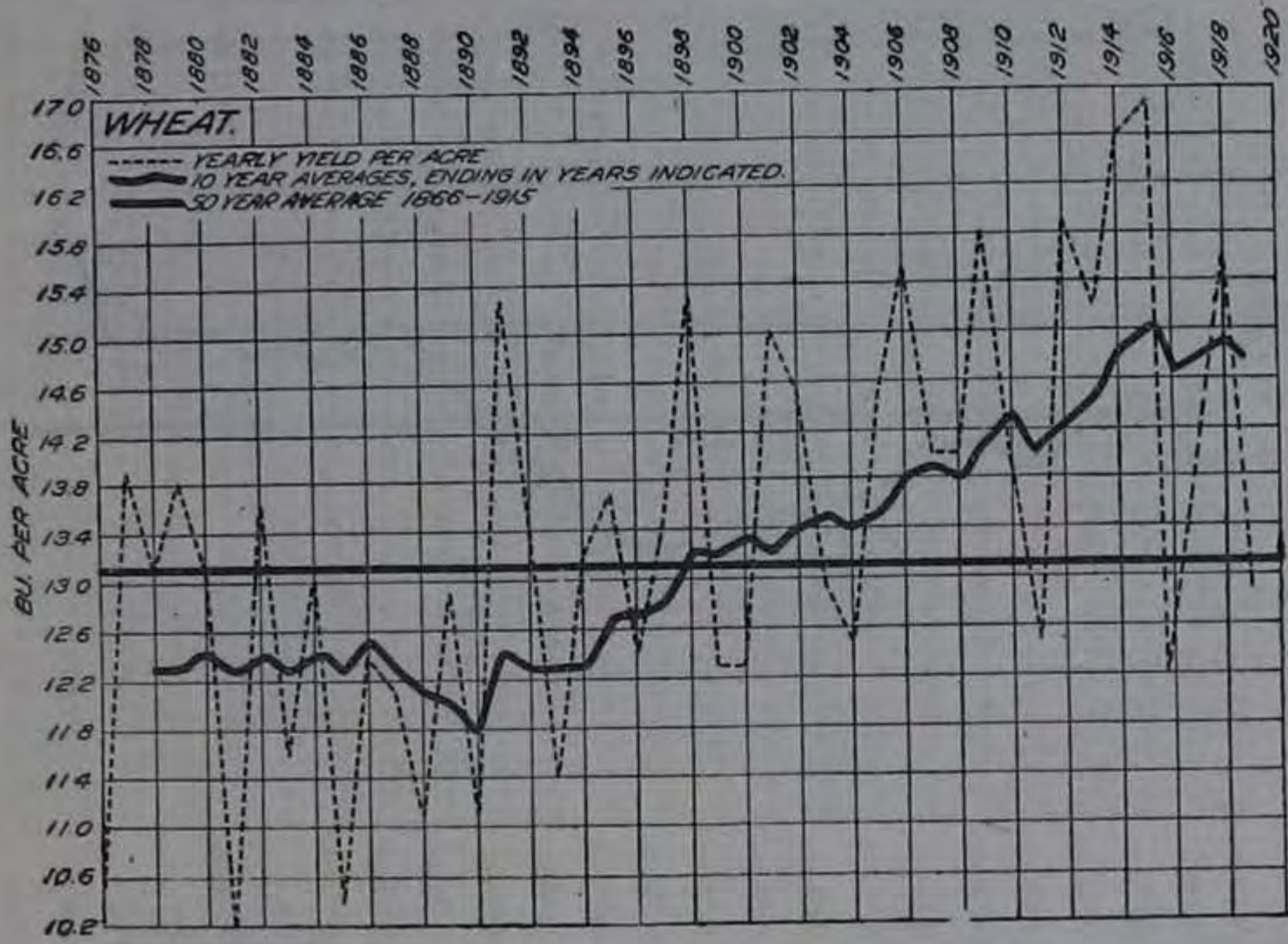

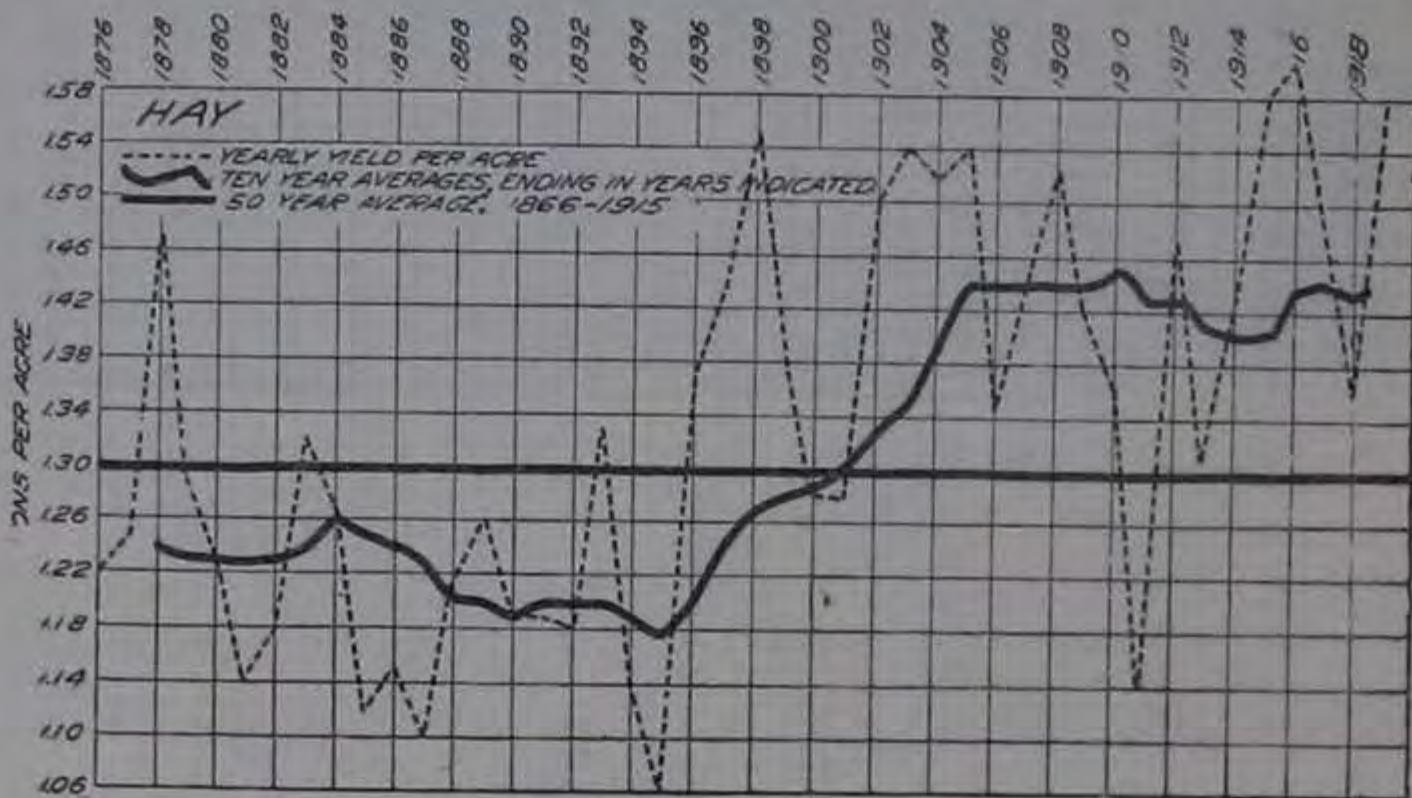
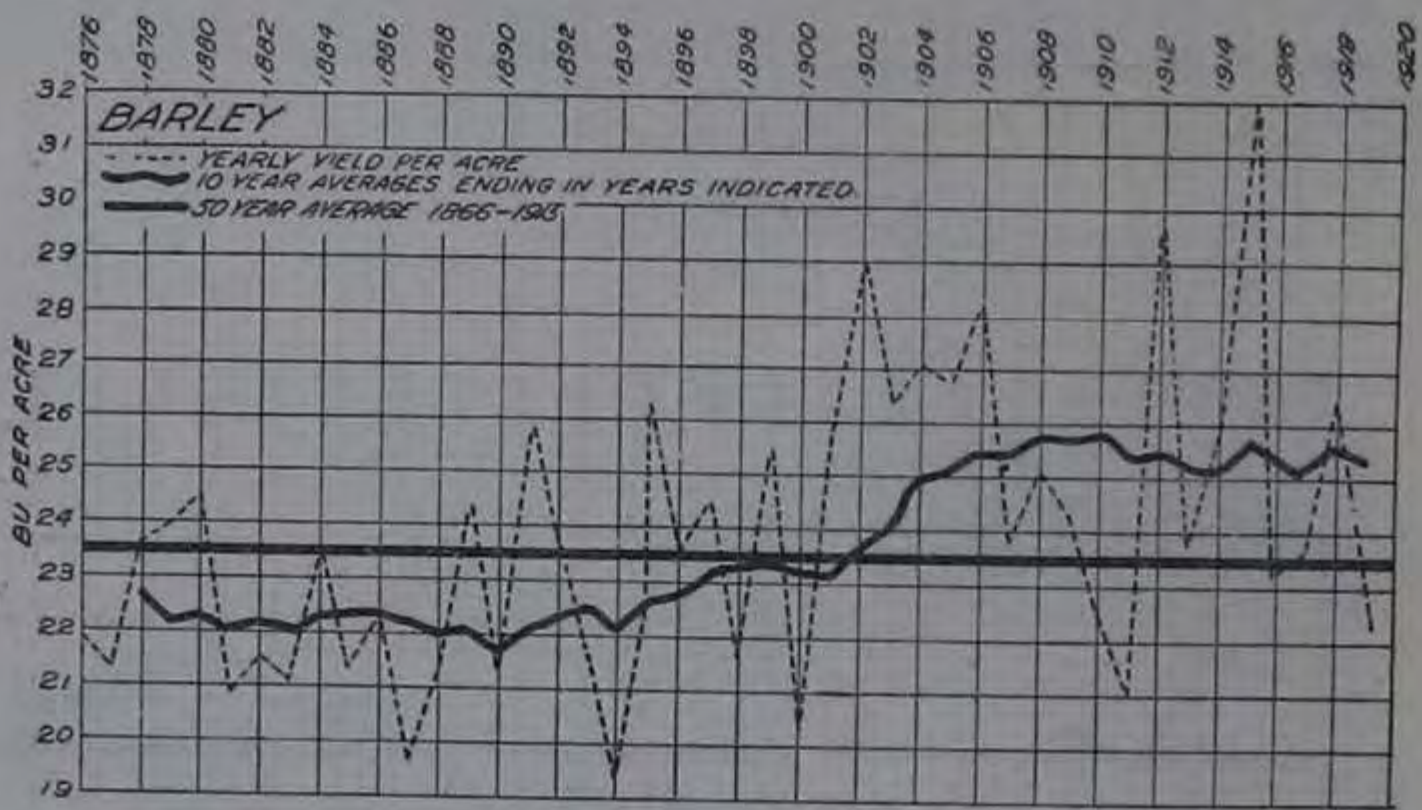
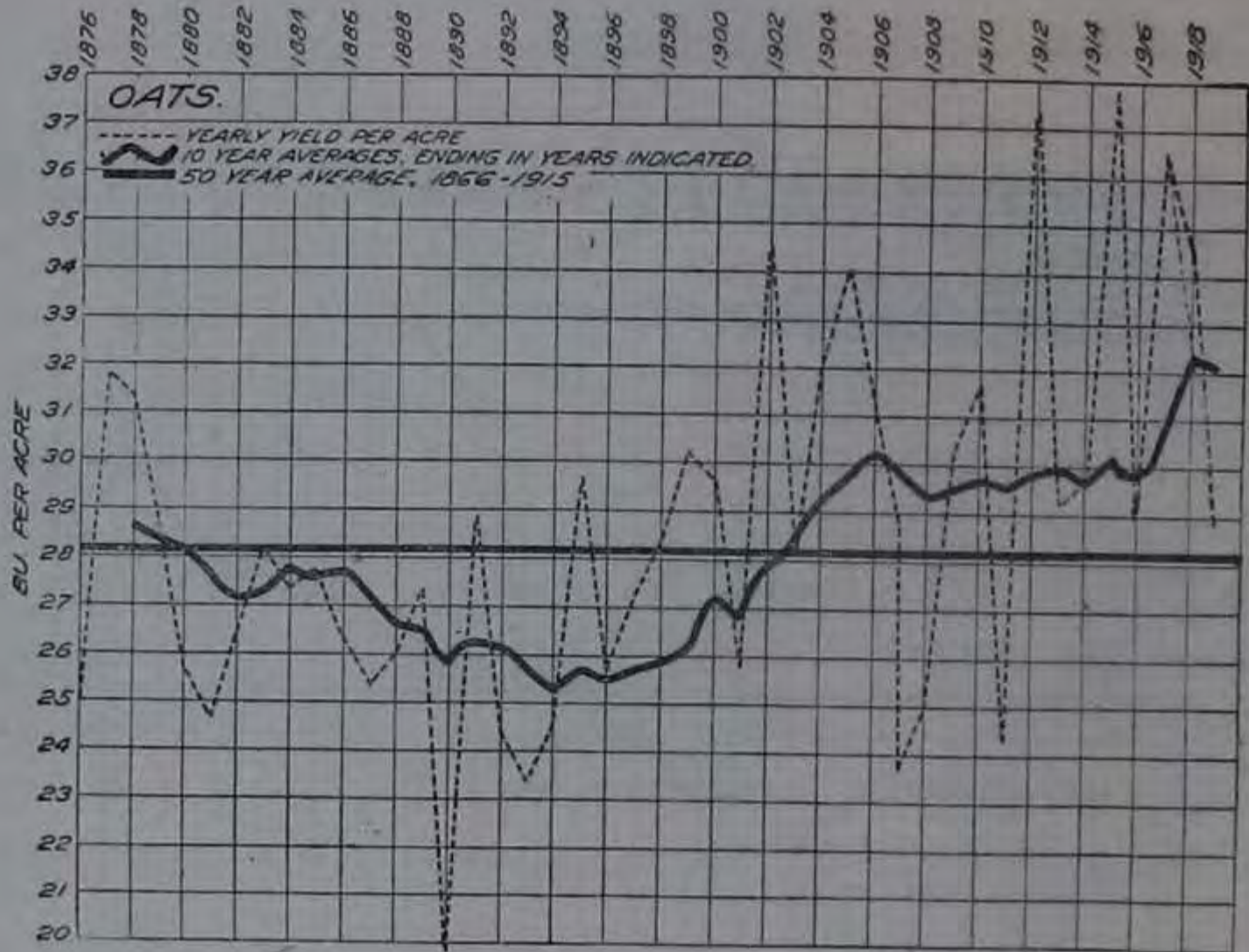

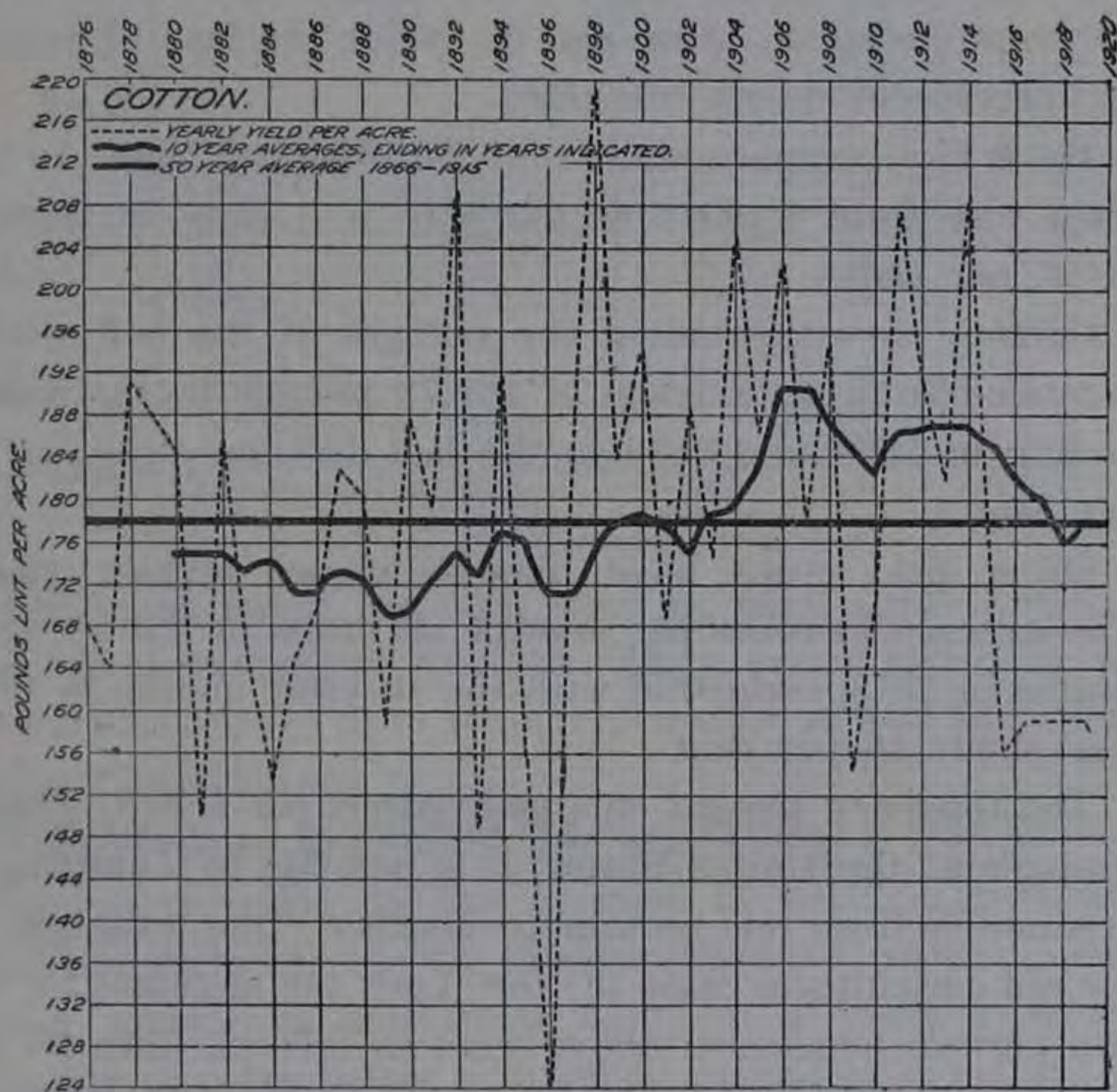
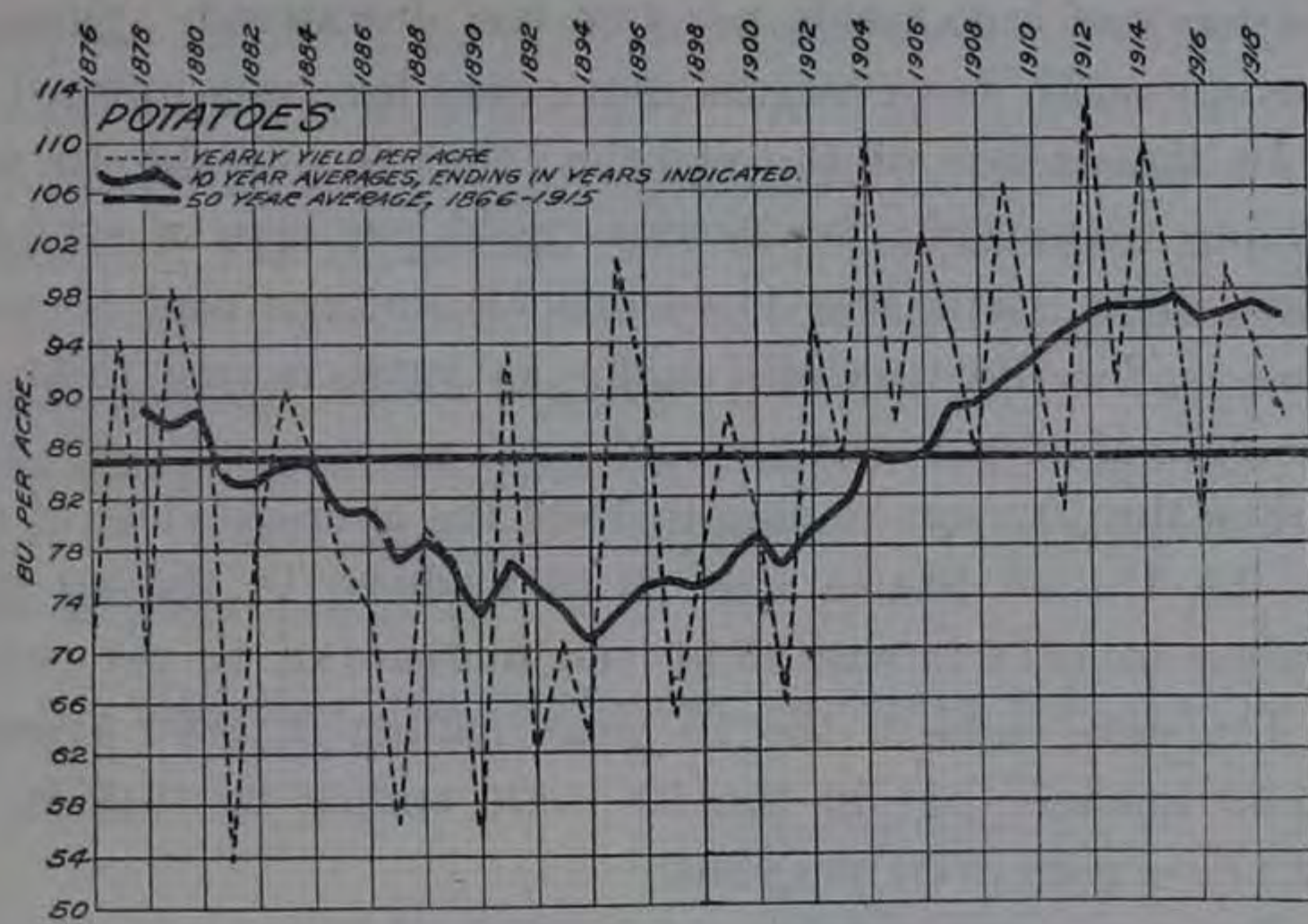

During the decades of the seventies and eighties, when there was a vast expansion of farm area in the West and crops were grown on a more and more extensive scale, the

tendency of crop yields per acre was downward. Since the early nineties, however, the movement has been upward.

In the decade of the eighties, that is, for the 10 years ending with 1890, the average yield per acre of wheat in the United States was 11.84 bushels; for the past 10 years, that is, for the 10 years ending in 1918, it was 14.87—an increase of 25 per cent.

For the 10 years ending in 1890 the average yield of corn in the United States was 23.43 bushels; in the 10 years ending in 1918 it was 25.81—an increase of 10 per cent.

The oats yield in the 10 years ending in 1890 averaged 25.92 bushels, but in the 10 years ending in 1918 it was 32.17—a gain of 24 per cent.

The potato crop averaged 72.97 bushels per acre for the 10 years ending in 1890, and 96.84 for the last 10 years—an increase of nearly one-third.

By a like comparison, it may be observed that the hay yield rose from 1.193 tons per acre to 1.432—an increase of 20 per cent.

Cotton, notwithstanding the ravages of the boll weevil, increased from an average of 169.78 pounds in the decade ending in 1890 to 175.73 in the last decade—a gain of 3.5 per cent.

Other field crops have likewise shown greater yields. The average increase per acre of all crops in the 10 years ending in 1918, compared with the 10 years ending in 1890, was about 16 per cent.

The tendency toward enlarged output per acre is general throughout the United States; it is not due to a shifting of production from one section to another. For example, in the old agricultural State of New York the increases for the two periods mentioned above were as follows: Corn 24 per cent, wheat 44, oats 21, barley 24, buckwheat 43, potatoes 30, hay 10, average of all (weighted) 18 per cent. The facts for the New England States may appeal to many as even more striking and significant. For the six New England

States, the following gains are shown in the 10-year period, 1909-1918, over the average for 1866-1875: Corn 33 per cent, wheat 63, oats 25, barley 27, rye 27, buckwheat 17, potatoes 27, hay 24, and all field crops 25 per cent; and for the 10 years, 1909-1918, over the average for 1881-1890: Corn 38 per cent, wheat 60, oats 24, barley 29, rye 44, buckwheat 45, potatoes 69, hay 23, and all field crops 26 per cent. For convenience of comparison, the accompanying table is inserted.

*Comparison of crop yields in six New England States.*

Crops.	Percentage increase in average yields per acre during 10 years, 1909-1918, over—	
	10-year average, 1866-1875.	10-year average, 1881-1890.
Corn.....	33	38
Wheat.....	63	60
Oats.....	25	24
Barley.....	27	29
Rye.....	27	44
Buckwheat.....	17	45
Potatoes.....	27	69
Hay.....	24	23
All field crops (weighted).....	25	26

The gains noted are real; that is, they are not due to changes in statistical method. They are observed in the official statistics of most foreign countries, as well as in those of the United States.

The increased production per acre shown is due, in considerable measure, to the practice of better agricultural methods, including the use of more efficient farm machinery; better knowledge and fuller adoption of crop rotations; planting of crops better adapted to prevailing climatic conditions; development and adoption of varieties more resistant to plant diseases and insect pests; more general application of disease and insect control measures; increased and

more intelligent use of fertilizers; and improved efficiency in crop production generally.

#### FOREIGN YIELDS ALSO INCREASED.

Not only in the United States, but in most civilized countries of the world, the yield per acre has been tending upward in recent years. This is noted in respect to wheat in practically all wheat-growing countries. If we compare the average wheat yields per acre in the 10-year period, 1891-1900, with those in 1901-1910, we find that in the United Kingdom there has been an improvement of 6 per cent, that is, from 30.1 to 31.9 bushels; in the Netherlands, of 19 per cent, or from 27.7 to 33; in New Zealand, of 28 per cent, or from 24.6 to 31.5; in Sweden, of 14 per cent, or from 24.2 to 27.6; in Germany, of 23 per cent, or from 23.6 to 29.1; in Ontario, of 12 per cent, or from 19.4 to 21.8; in Manitoba, of 7 per cent, or from 17 to 18.2; in France of 8 per cent, or from 18.1 to 19.5; in Hungary, of 3 per cent, or from 17.3 to 17.8; in Japan, of over 2 per cent, or from 17 to 17.4; in Poland, of 3 per cent, or from 15.5 to 15.9; in Roumania, of 21 per cent, or from 14 to 16.9; in the United States, of 8 per cent, or from 12.9 to 13.9; in India, of 16 per cent, or from 9.7 to 11.3; in Caucasia, of 18 per cent, or from 9.5 to 11.2; in Russia, excluding Poland and Caucasia, of 14 per cent, or from 8.3 to 9.5 bushels. These countries are given in the order of their relative rank in yield per acre during the period 1891-1900. Satisfactory comparative data are not available for Argentina. Similar gains have been observed in other crops.

The average yields in the United States are frequently compared with the much larger yields in some European nations. In Belgium the average yield is about double that in the United States; in the United Kingdom, more than 60 per cent greater, and in France, nearly 15 per cent. It should be borne in mind, however, that the energy of each American farmer is spread over a larger area and that, although he produces less per acre, he produces much more

per man. The total output of the average farmer is probably greater in the United States than in any other country in the world. Thus, in Belgium, with its intensive system of farming, only about 5.3 acres are cultivated for each person engaged in agriculture, whereas, in the United States, the corresponding figure is 27 acres. Taking both acreage and yield per acre into consideration, the average American farmer produces 2.5 times as much as the average Belgian farmer; 2.3 times as much as the English; 3.2 times as much as the French; 2.5 times as much as the German; and over 6 times as much as the Italian.

For many years to come the average yield per acre in the United States may be expected to increase, although the total output per man may diminish. This country has a long distance to go before it comes in sight of its limit of farm production. It can further increase its output of commodities by continuing to secure increased yields per acre. It has been estimated by experts that only about 15 per cent of the land in cultivation is yielding reasonably full returns. The opportunity is presented, as conditions warrant, to bring the remaining 85 per cent up to the point of fair yield. One of the objectives of all good farmers and of the agricultural agencies assisting them is to promote increased yields along economic lines by the further application of scientific knowledge and the adoption of improved practices. The path of progress is pretty well charted and the agricultural forces are moving along it with gratifying speed. However, the maintenance of satisfactory increases necessitates the continuance and enlargement of investigational work, particularly such as is required to insure fuller control of destructive plant diseases and insect pests.

#### FARM LAND PROBLEMS.

The Nation can further expand its output of commodities by cultivating the tillable land which at present is unused, estimated to be over 60 per cent of the total. But there has



been no such full consideration of the policy which should be pursued in reference to the extension of the farm area as has been given to economical production. Since the Nation now retains but little land of ready availability, agricultural expansion will result mainly from efforts to utilize and to increase the productivity of farm lands now owned by individuals, corporations, and the States.

A number of important questions must be answered: How rapidly should new areas be developed? What means should be employed to bring new lands into use, so that settlers may achieve success, employ sound methods of husbandry, and establish a wholesome community life? What is the significance of the increase of tenancy and what may be done to establish a system of land tenure which will insure good farming and a sound and democratic foundation for American agriculture? What is the bearing of the increasing prices of land and the resulting speculation on the progress of agriculture and the welfare of the farmer?

#### EXPANSION OF AREA IN FARMS.

The expansion of the Nation's agriculture is limited by the supply of labor and capital available for farming purposes rather than by the scarcity of undeveloped lands. It is true that, in general, the best land is already in cultivation, but without question much of the remainder can be tilled when the country reaches the economic stage which would justify its utilization.

There are numerous fallacious opinions with respect to the need of extending the farm area. Many people, noting the prevailing prices of agricultural products, demand increased production and insist that the remedy lies in immediate and rapid expansion of the acreage in farms. Others, observing large tracts of unused land, deplore the great waste of our resources. Still others explain the movement of population from rural districts to cities by the nonavailability of land, which they attribute to land monopoly, speculation, and

other evils. The demand for farm products, unlike the demand for manufactured articles, does not expand rapidly to meet a large increase in supply. There is a tendency toward an equilibrium between urban and agricultural industry. If too much labor and capital are diverted from farming, the relative prices, and consequently the relative profits, of agricultural activity will increase, and there will be a tendency toward expansion. If this is excessive, however, relative prices and profits will tend to decrease and the industry may suffer depression. The inelasticity of demand for farm products sets a very decided limit at a given time to the increase of population and capital profitably employed in agriculture.

It is not in the interest of producers or consumers to have large fluctuations in agricultural production. There is always danger of glutting the market and of serious loss. The aim rather should be to secure a steady flow of commodities of sufficient volume to supply an increasing demand at prices which will yield the farmer a decent wage and a fair profit on his investment. It seems difficult to get it into the minds of some people that farming is a business and must pay; that under modern conditions there can not be an unlimited number of farmers. There could be a larger proportion of farmers to total population if each farm were self-sufficient and produced no surplus of consequence, but to-day the average farmer produces many times what he consumes of some things and is dependent for his prosperity upon their profitable exchange for other articles which he uses. There should be, and in the long run there will tend to be, no more farmers in the Nation than are needed to produce the quantity of products which can be disposed of at a profit. There will be farmers enough if the business of farming is made profitable and if rural life is made attractive and healthful. The consumers must be willing to pay prices for farm products which will enable farmers to produce them and to maintain a satisfactory standard of individual and commu-

nity life. The Nation also must be prepared to omit nothing to improve the countryside. It is of the first importance that satisfactory schools, with courses of study related to the problems of rural life, be provided, that good roads be constructed, and that adequate provision be made to give rural communities the requisite sanitary and medical services, including hospital facilities. When these requirements are met, we shall not have to concern ourselves as to the number of farmers and the adequacy of our agricultural production. There will then be no difficulty in retaining in the rural districts a sufficient number of contented and efficient people. What we need is not a "back to the land" propaganda, but an acceleration of the movement for the improvement of the countryside which will render the abandonment of farms unnecessary and the expansion of farming inevitable.

There is reason to believe that a considerable expansion in farm-land area occurred during the war. The acreage devoted to the 19 principal crops increased 10.1 per cent from 1914 to 1918. Accordingly, the crop area per capita increased from 3.22 acres in 1914 to 3.33 in 1918, or 3.4 per cent. This expansion probably resulted in part from the use for crops of land normally devoted to other purposes, especially to pasture. However, it seems to indicate that the farming industry has more than held its own during the period. This conclusion is confirmed by an increase not only in the per capita production of nearly all the important crops, but also, according to a recent report, in the number of cattle and swine per capita. Moreover, estimates for milk, eggs, and poultry indicate an increase in per capita production during the war. In view of these facts, it probably would be unwise to stimulate a large increase in the per capita farm acreage at the present time, especially where such an increase would have to be effected by utilizing land which is inferior or which would be made available at a heavy outlay for drainage, irrigation, or clearing. Apparently, therefore, American agriculture should consolidate

the gains already made; prepare for the period of competition which is to be expected with the return of normal world conditions, principally by increasing, through sound and economical methods, the productivity of areas already under cultivation; and utilize the services of the most experienced and judicious agricultural leaders in determining where, when, and how to bring into cultivation and develop public and private unused land.

The best experts of the Federal department and of the agricultural colleges should make a careful investigation of the possibilities of utilizing land not now devoted to agriculture. In respect to the 200,000,000 acres of cut-over land, the 60,000,000 requiring drainage, and the 30,000,000 which may be irrigated, there is great variation from district to district as to the possibility of economic use. Distinctive regions should be fully studied with a view to assemble all existing data on productivity, cost of making the land available, present tenure and prices, type of agriculture best adapted to the conditions, possible returns, minimum size of farms capable of supporting families in reasonable comfort, minimum equipment needed at the beginning of settlement, sources of credit, and marketing and transportation facilities.

#### LAND SETTLEMENT.

At present various private agencies are engaged in promoting land settlement. Many of them are honest in intention, promise, and practice; others keep within the letter of the law but, through exaggeration and indirection of statement, create false impressions in the mind of the settler. Many violate no canon of fair business practice, but their interest is in profits and they do not pursue a policy calculated to develop a profitable and wholesome community life. Only a few have made careful studies of the conditions of successful settlement and developed their business with a view to the settlers' progress and success.

Practically all are seeking to realize the highest possible price for their undeveloped holdings, and the settler is compelled to face the problem of adjustment to pioneer conditions while carrying a burden of land value which often represents, in part, the capitalization of a future increase in earning power.

The intending settler of small means is rarely able to distinguish between the good and bad methods of selling land in new regions. The more unscrupulous the land company the more lurid are its advertisements and the more extravagant its promises. Settlers often are induced to invest all their savings in land not suitable for successful farming, to purchase more land in relation to the capital available for development than they should, or to undertake projects the cost of clearing or reclamation of which will prove to be prohibitive. The results, in many instances, have been tragic failures after years of incredible hardships, waste of capital and of human lives, discouragement of intending settlers, and injury to the business of legitimate and well-meaning land concerns.

It would be desirable if governmental agencies, by systematic aid, should furnish reliable information to those seeking farms, should take particular pains, through their agricultural machinery, to give new settlers very special assistance and guidance, and, where conditions are favorable, should aid in the development of well-considered settlement plans.

#### TENANCY.

The increase of tenancy has become the subject of deep concern to thoughtful students of rural conditions. The tenant, on an average, remains on the same farm only about one-sixth as long as the owning farmer. Consequently, he often manifests little interest in the improvement of the farm and in the progress of the community. A certain proportion of tenants is normal and may not be unwholesome. Many farm owners, because of age or infirmity, find it necessary to

retire. Their farms are temporarily operated by their sons or other relatives who subsequently may become owners through inheritance or purchase. Large numbers of young men with little capital find tenancy a convenient stage in their progress to ownership. Certain local studies reveal the fact that nearly two-thirds of the farm owners who operate their farms have passed through this stage. Frequently it serves as a useful period of apprenticeship in farm management before the heavier financial burdens of ownership are assumed.

In a great many cases the farmer has not yet acquired sufficient experience as a manager to operate his farm efficiently without the assistance of the landlord. In some instances, also, the tenant has been reared in an environment characterized by lack of thrift, self-restraint, and systematic industry. He may not have the general intelligence or technical knowledge to stand alone in the management of a farm. Where these personal limitations exist the solution of the problem lies in education, training, and the development of systematic habits of industry and thrift rather than in radical changes in the system of tenure.

Since there will continue to be a certain number of tenants, every effort should be made to change the conditions of leasing so as to improve the methods of agriculture, increase the period of occupancy, and insure a fair division of returns; and the States should provide by law for a system of compensation by owners to tenants for unexhausted improvements and set up the necessary administrative machinery. Such arrangements have prevailed in England for many years to the benefit of all concerned.

Although landlords may, and often do, play an important part in financing and in operating farms, there are large numbers who live at a distance and who contribute nothing toward their efficient utilization or improvement. Moreover, they often fail to interest themselves in promoting the progress of the community in which their land is situated, although they benefit by such progress. Land, however, is peculiarly

important to all the people and the welfare and prosperity of the community, as well as its economic and social progress, depend so vitally on its use and the relationship of the population to it that serious thought must be given to the problem of limiting absentee ownership.

The endeavor to develop a more harmonious and efficient relation between tenant and landlord and to restrict absentee landlordism does not obviate the necessity of taking measures to retard the increase of tenancy. The road to farm ownership should be made as smooth as possible. This may be accomplished in part by providing more liberal credit facilities. The Federal Farm-Loan System has furnished a means whereby farmers may conveniently borrow under the conservative conditions of first-mortgage security. However, an analysis of the amount loaned shows that only a small proportion of the net proceeds was ostensibly obtained for the purchase of farms.

In some sections the growth of tenancy has been stimulated by the fact that the price of land has been higher than the level justified by current earnings. Consequently, it has been more profitable to rent than to buy unless one wished to speculate in land values. Recently there has been a tendency for prices to increase with extreme rapidity. There has been active, and in many respects unwholesome, speculation which has profited mainly the real estate agents. A heavy charge, therefore, has been placed against the earnings of the land on the assumption of the continuance of war prices. The advancing price of land is especially serious in the case of the undeveloped regions of the country. It constitutes an obstacle to development, for the actual settler is compelled to assume at the outset unduly heavy interest charges.

#### EXTENSION OF FORESTRY.

The continued dissipation of privately owned forests in every timber-producing region of the country is a matter of grave concern. The public does not fully realize its

seriousness. If the area having little or no value for other than forest purposes is not protected, much of it will become practically nonproductive. Millions of acres in the older parts of the country where supplies of timber are needed by the communities have become almost valueless. Where the land is not valuable for agriculture large-scale lumbering operations are followed by local industrial depression, the timber industries migrate, population decreases, farmers lose their local market, taxable values decline, schools and roads deteriorate, and the economic and social life of the community suffer.

The problem presented is very difficult. Public forests are confined to relatively limited areas, except in the West. These will by no means supply the future needs of the country. At present the greater part of the lumber produced annually is cut from private lands on which the appearance of new growth is at best a matter of accident, is likely to be long delayed, or may never occur. Without concerted action under public cooperation and direction the problem will not be solved. Private initiative can not be depended upon to secure the requisite conservation.

The preservation of forests in all forest regions is of immediate concern and importance to farmers. Timber is an important farm crop. Farm woodlands comprise about 20 per cent of the farm area of the country. At the last census the value of the products from them was greater than that of the potato crop and nearly double that of the tobacco yield. Forestry, therefore, must be assigned a place in farm management. Farmers also are vitally concerned with national forestry problems. They consume more wood than any other group and they are interested in seeing that there is available, at reasonable prices, a continuous supply of lumber and other forest products. A sound forestry policy does not conflict with agricultural settlement. In fact, it facilitates the cultivation of land



suitable for agriculture, and also seeks to secure the proper handling of existing forests and the reforestation of denuded regions. On the other hand, forest devastation retards agricultural development.

#### NECESSARY STEPS.

Certain things seem clear. Fire is a great menace not only on forested but also on cut-over areas. Adequate protection, therefore, should be required of all owners. The public, through both the State and Federal Governments, should cooperate in organizing this service and should share the cost of maintaining it. It should also adopt such practical measures as may be necessary to bring about the discontinuance of all practices which result in turning the forests into wastes, and should aid private owners to perpetuate their forests by proper management. A well-balanced policy requires a much larger program of publicly owned forests than at present. The acquisition of forest lands by the Federal Government is now proceeding under the Weeks forestry law. The total area approved for purchase to date is 1,835,298 acres. The continuation of the policy is sought by the National Forest Reservation Commission, and an estimate of an appropriation of \$10,000,000 will be placed before the Congress. And, furthermore, the consolidation of National Forest areas through exchange with private owners should be accelerated. There are now pending no less than 25 bills authorizing exchanges, and the enactment of a general law would be in the public interest. There is a growing demand for additions to the National Forests from the public lands in the States where such action is possible only through legislation. Recently a law authorizing the addition of 1,000,000 acres to the National Forests in central Idaho has been enacted.

Good forestry practice rests upon the possession of full and accurate data. Our present knowledge of the methods of securing the largest yields is inadequate. There is need

of further information regarding the amount, quality, and distribution of existing timber supplies. A detailed inventory of our present resources and a survey of present and prospective needs are essential for constructive planning.

#### FARM MANAGEMENT AND FARM ECONOMICS.

Until comparatively recently studies in farm economics were neglected. In the last 10 or 15 years it has come to be recognized that the prosperity of the farmer depends as much upon good business methods as upon his practices in plant culture and animal husbandry. In 1906 the Department of Agriculture inaugurated investigations in farm management, which remained in the Bureau of Plant Industry until 1915, when the Office of Farm Management was established as a branch of the Office of the Secretary. During the latter part of the calendar year 1918 steps were taken to reorganize the work. At my request, a committee composed of recognized authorities on farm management and agricultural economics made a thorough study of the activities of the office, not only with a view to enlarge the scope and increase the efficiency of the work but also to outline definite methods of procedure to be followed in the study of farm-management problems, and especially the cost of producing agricultural products. The members of this committee were: G. F. Warren, professor of agricultural economics and farm management, State College of Agriculture, Ithaca, N. Y.; Andrew Boss, chief of the division of agronomy and farm management, State College of Agriculture, St. Paul, Minn.; H. C. Taylor, head of the department of agricultural economics, College of Agriculture of the University of Wisconsin, Madison, Wis.; J. A. Foord, professor of farm management, State College of Agriculture, Amherst, Mass.; J. I. Falconer, professor of rural economics, State College of Agriculture, Columbus, Ohio; R. L. Adams, professor of agronomy, State College of Agriculture, Berkeley, Calif.; and G. I. Christie, Assistant Secretary of Agriculture and director of extension in Indiana.

This committee submitted a report to me, which I approved and which has been published as Circular No. 132 of the Office of the Secretary. It not only outlined the field of work of the Office of Farm Management but also recommended that its name be changed to Bureau of Farm Management and Farm Economics, and that the investigations conducted by it be carried on in close cooperation with the agricultural colleges and experiment stations in order to prevent duplication of effort, to promote the development of farm-management activities in the various States, and to unify the methods and improve the general character of all farm-management work. On the basis of these recommendations, separate conferences were held for the purpose of indicating in greater detail the activities proposed by the reorganization committee, and especially to consider the projects relating to cost of production, farm organization, land utilization, and farm life.

These conferences resulted in the following approved projects:

(1) **COST OF PRODUCTION STUDIES.**—The value and importance of such studies are set forth clearly in the report of the reorganization committee, as follows:

Cost of production studies are of value to the individual farmer and, at the same time, are helpful in ascertaining the economic status of farming as an industry.

From the standpoint of the individual farmer the primary purposes are:

- (1) To record the details of the farm business for reference.
- (2) To give an insight into the elements and interrelations of the different farm activities.
- (3) To furnish information that may enable the farmer to reduce costs or otherwise increase profits.
- (4) To make possible a comparison of the profitableness of the different enterprises and combinations of enterprises.

The records secured by cost of production studies give data for analyzing the farm business, and thus are of fundamental importance in the whole program of agricultural research and education. The results of such studies on a number of farms where a given type of farming is practiced are useful not only to the farmers from whose farms the results were obtained, but are of value in showing other farmers how to improve their methods.

From the standpoint of the public, cost of production studies provide the facts which give a basis for intelligent judgment upon the probable effects of any given legislation or other public activity upon the farmer as a producer and as a citizen. Cost of production studies are therefore one of the means of providing the basic facts needed by legislators and price commissions in comparing the profits of competing lines of production and estimating necessary price.

(2) **FARM-LIFE STUDIES.**—These studies are to be conducted with a view to make living conditions in the home and in the community more satisfactory to the farm family. They will cover the following topics: Rural home life; opportunities for social contacts in typical rural communities; the relation of educational and religious institutions to farm-life problems; problems relating to geographical population groups, such as the relation of urban and rural populations, the shifting of rural populations, race elements in rural districts; social aspects of tenancy and landlordism; rural organizations, their efficiency, scope, causes of success and failure; social aspects of various types of farm labor—the married and unmarried farm hand, seasonal and child labor; the relation of various forms of disability—the aged, illiterate, defective, dependent, delinquent—to farm-life problems; and the social consequences of local disasters due to natural causes, as well as of thrift and agencies for promoting it.

(3) **LAND ECONOMICS (LAND UTILIZATION)**, involving the consideration of land resources, values, ownership and tenancy, settlement and colonization, and land policies.

(4) **FARM ORGANIZATION.**

(5) **FARM FINANCIAL RELATIONS.**

(6) **FARM LABOR STUDIES.**

(7) **AGRICULTURAL HISTORY AND GEOGRAPHY;** and

(8) **DEMONSTRATION ACTIVITIES.**

The supervision of the task of executing the new program was assigned to Dr. H. C. Taylor, who was appointed Chief of the Office of Farm Management. Dr. Taylor, before accepting this position, owned and operated a farm in

Wisconsin and also was head of the department of agricultural economics in the college of agriculture, University of Wisconsin. The department also secured the services of Mr. Francis W. Peck, of the University of Minnesota, who has had wide experience in studies of the cost of producing farm products, to take charge of the enlarged activities in this important field; of Dr. L. C. Gray, of Peabody College, to direct the work relating to land economics; and of Prof. C. J. Galpin, of the college of agriculture of the University of Wisconsin, to supervise the farm-life studies. This is merely a part of the plan to secure some of the best available minds in the country to direct the work relating to farm management and farm economics.

#### APPROPRIATIONS REQUIRED.

Arrangements promptly were made to develop the activities of the Office of Farm Management along the lines suggested by the reorganization committee. As it was clear that existing funds were inadequate, I submitted to the Congress, on May 23, 1919, a revised estimate calling for appropriations, during the fiscal year 1920, aggregating \$611,990, compared with \$305,090 during the fiscal year 1919, an increase of \$306,900. Aside from statutory salaries, it was proposed to allot the appropriation to the following lines of work, in the amounts indicated:

Cost of production studies.....	\$245, 000
Farm organization.....	53, 600
Farm finance and farm relations.....	21, 560
Agricultural history and geography.....	29, 200
Land economics (land utilization).....	112, 920
Farm-life studies.....	20, 560
Demonstration activities (extension work).....	32, 820

It was hoped that the necessary additional funds would be included in the agricultural appropriation bill for 1920, which was then pending. Unfortunately, however, Congress did not take favorable action on the proposal. It not only did not grant the increases recommended but inserted a proviso in the bill which restricts the amount that may

be expended on cost of production studies during the present fiscal year to \$23,873.

Although the funds at the disposal of the office were small, every effort has been made to carry out the reorganization program along the lines indicated. I am renewing, in the estimates of the department for the fiscal year 1921, the recommendation that approximately \$611,900 be provided, and that the name of the present Office of Farm Management be changed to Bureau of Farm Management and Farm Economics.

Having secured the best experts available to direct the principal activities of the office, I am confident that the work now under way and proposed, if the necessary funds are appropriated, will be executed in a highly satisfactory way, and that facts and information of immense value to individual farmers in dealing with their own problems, and also to the Nation for its guidance in considering broad agricultural policies, will be obtained and made available.

#### CROP AND LIVE-STOCK REPORTING SERVICE.

Accurate and complete statistics are prerequisite to the satisfactory consideration of any problem. They are of overwhelming importance to the millions of people interested in rural life, and especially those charged with the responsibility of aiding, by legislative and administrative processes, the successful development of our great agricultural industry. Suggestions as to the direction of production and plans to improve marketing and distribution wait upon them, and in any national crisis they are essential to the intelligent handling of the Nation's food problems. In this direction, as in many others, the war has brought home in very direct fashion the need of improvement.

The value of dependable information on acreage, crop yield, number of live stock, and farm surpluses can not be overestimated. The Bureau of Crop Estimates has slowly developed an organization to secure and verify many valuable

data. It is now necessary to extend it. The time has arrived for placing the work in all the States on a county basis. It is important that the live-stock and feed-reporting service be enlarged, that farm surpluses be ascertained, and that information regarding foreign crop and live-stock production be more fully secured and reported. It is peculiarly urgent that this be done at the present time. The 1920 census is about to be taken. It will furnish new base-lines, and the department should be in a position, by reason of an improved service, to supply the country each year after the census with as full and accurate data as possible.

Estimates to make it practicable for the department to execute the enlarged program will be laid before the Congress for consideration at its regular session. If they are approved, the field force of the bureau will be strengthened by placing an assistant field agent and a clerk in each State. Additional specialists also will be appointed to collect, interpret, and present information regarding special crops and classes of live stock. The bureau then will be in a position to report for the Nation as a whole, for each State, and for each county, monthly or oftener if necessary, acreages to be planted; surpluses or deficiencies of seed, fertilizer, labor, and farm machinery; acreages actually planted; progress of farm work; acreages abandoned and harvested; damage from weather conditions, insects, and plant diseases; condition of crops and forecasts of production; yields per acre and production at or near harvest; acreages and yields of principal varieties of each crop; disposition and utilization of the crops produced; marketable surpluses and stocks on farms; prices received by farmers as distinguished from market quotations; prices farmers pay for supplies, machinery, and equipment; hours and wages of farm labor; and the foreign situation. These reports will cover about 70 crops, including such special items as vegetables, nuts, fruits, seed, oils, forest products,

and nursery stock, for all which adequate reports have not been available except in the census years.

Likewise, there will be given the number of horses, mules, dairy cattle, beef cattle, swine, sheep, goats, and poultry, by age and sex classifications corresponding with the census enumeration of January, 1920; of purebred animals of each kind; of those bred, born, or brought on to the farm; of those sold, slaughtered, or lost through disease, exposure, or other causes; of those remaining on hand and on feed; the condition of the various classes of animals; farm prices; and the feed situation, including the carrying capacity of pastures and ranges, the number of silos, the quantity of silage and other forage available, as well as the domestic meat, dairy, poultry, wool, and hide production, and the foreign situation.

Available foreign crop and live-stock estimates will be secured and published, especially for countries of deficient supply and those of surplus production in competition with the United States, and periodical world balance sheets will be prepared, showing for the principal countries of the world the production requirements, imports, exports, and net deficiencies or surpluses of the major crops and classes of live stock.

It is proposed to establish intimate cooperative relations with State departments of agriculture and State assessors. In this way greater accuracy will be secured and the aggregate expense to the States and the Nation reduced. As the value of reports depends not only on their completeness and accuracy but also on their quick availability, they will be issued very promptly and more frequently, summaries will be released on dates of issuance, and the Crop Reporter will be changed from a monthly to a weekly basis.

#### VALUE OF COMPLETE ESTIMATES.

It need scarcely be pointed out that county estimates are of great importance to the work of the county agents and the extension service in each State, to manufacturers



and business men who supply farmers with equipment and machinery, to banks which furnish funds for financing crop production and movements, and to transportation companies for supplying cars when and where needed to move crops. They have already been made in a number of States. Preliminary estimates of acreages intended to be planted will enable farmers to determine whether their plans should be modified. Estimates of surpluses or deficiencies in the supplies of seed, fertilizers, and farm help tend to equalize both distribution and prices and to insure adequate farm production. Estimates of acreage, yield per acre, and production of each principal variety of a given crop, in addition to total production of the entire crop, will show the relative adaptability and productivity of varieties, and therefore will be of assistance not only to farmers but also to seedsmen and to crop specialists and plant breeders of the State experiment stations and of the Federal Department of Agriculture. Those of crop damage by counties from insect pests and plant diseases will enable the entomologists and plant pathologists to work more intelligently in developing and applying remedies. Those of marketable surpluses on farms, or the portion of the crop sold from the farm and entering the channels of trade, will facilitate the satisfactory marketing and distribution of surplus production. Such estimates have been made for apples, peaches, potatoes, and truck crops, and they were promptly and effectively utilized by growers and marketing agencies.

Perhaps the most important feature of the enlarged program is that relating to live stock, which represents not only a farm investment of more than \$10,000,000,000 but also constitutes the meat supply of the Nation, a considerable portion of the export trade, a very important factor of successful farm management and economy, and 50 per cent of all farm sales. Yet for this important industry the bureau, with its inadequate facilities, has been

able to estimate, once a year, only the gross number of animals on farms, the number of brood sows, and the total losses from disease and exposure. No attempt has been made in the past to estimate dairy and poultry production between censuses, the annual value of which amounts to approximately \$3,000,000,000. The great losses occurring yearly from drought and feed shortage in portions of the Great Plains and in limited areas of other sections might, to a considerable extent, be reduced by having definite and detailed information regarding the feed situation.

The expenditure of money for the execution of this program will clearly be an investment, which should be made without delay in order that agricultural and business interests may have the benefit of the improved service during the period of readjustment. It should be borne in mind also that the proposals are in no sense experimental. Their feasibility and practical value have been fully demonstrated.

#### MARKETING AND DISTRIBUTION.

In the field of distribution, as well as in the field of production, the farmers of the Nation must assume the main tasks of improvement. The Government should furnish all possible aid in the way of information and suggestion, create favorable conditions under which production and distribution may take place, and especially see that the channels of trade are open and that abuses do not exist.

The present time is especially fruitful of proposals of a large and novel nature designed quickly to solve marketing problems. Recently measures have been introduced into the Congress proposing a private or a governmental agency of national range, with State and county subdivisions, to supervise, or even to direct, the handling or marketing of the Nation's farm products. The probability is that an undertaking of such character would break down of its own weight. There is no question that everything which can legitimately be done to eliminate

waste in marketing and to promote orderly distribution should be done. But the views of the most experienced students of the matter seem to be that we must approach the problem in simpler terms, work along lines which have clearly proven to be feasible, and promote existing tendencies and practices.

Certainly, we can proceed further, by State, Federal, and individual action, in standardizing the production, the handling, and the packing of farm products, and in promoting the use of standard containers and proper storage on farms, in transit, and at market centers. We can continue to furnish assistance in the preparation and installation of accounting systems, and more extensively and accurately gather and furnish to the farmers of the Nation all pertinent statistical information. I need scarcely emphasize the paramount importance of making available daily to producers facts as to market prices, supplies, and demands. The market news services of the Department of Agriculture have already clearly proved their value. The department now conducts and operates an inspection service on fruits and vegetables covering 164 markets. It publishes reports on the supply, commercial movement, and prices of most of the important products and, in cooperation with 14 States, is issuing exchange marketing lists which make known to county agents, breeders, and feeders in these States, where surpluses of live stock, feeds, and seeds are to be found. It is estimated that last year, through such service, the farmers in Iowa alone made local exchanges having an estimated value of \$1,500,000.

#### COOPERATIVE ASSOCIATIONS.

Particularly must the Federal and State agencies omit nothing to promote farmers' cooperative associations along right lines. Already, within a generation, many such bodies have appeared and rapidly expanded. It is estimated that they now market annually approximately \$1,500,000,000

worth of commodities. They are of very diverse forms and sizes. For the most part, where they have been successful, they have centered their activities on some one product, or on related products, in a given area. The indications are that, with the continued success of these enterprises and with the proper educational effort and direction, they will develop even more rapidly in the future. Through bulletins, news articles, and lectures, the Department of Agriculture has endeavored to stimulate these efforts. It has furnished suggestions for State legislation governing their organization and, in cooperation with 23 States, it has employed trained specialists to advise extension workers, including county agents, and others, with reference to cooperative marketing.

As I have said, the rational program would seem to be to expand these activities, which have clearly demonstrated their value, to follow the scent as it were, and further to develop the machinery through which increased assistance may be furnished. There should be in every State one or more trained market specialists of the Department of Agriculture, working in cooperation with the proper State authority, to stimulate cooperative enterprises and to aid farmers in their marketing work by helpful suggestions as to plans and methods. These experts could very effectively aid the extension workers. County agents generally have the assistance of specialists in many other lines, but at present they have not the requisite aid in distribution. They can not be expected to be expert in all agricultural matters or to be omniscient. The department is requesting increased funds to make this extension possible and will take the necessary action promptly if the appropriations are made.

#### GOOD ROADS.

Good roads are essential to the prosperity and well-being of urban and rural communities alike. They are prerequisite for the orderly and systematic marketing of farm

products, for the establishment of satisfactory rural schools, and for the development of a richer and more attractive rural life. Recognizing these facts, the Federal Government, through the passage of the Federal aid road act in 1916, inaugurated a policy of direct financial participation in road-building operations in the various States. This act appropriated \$75,000,000, to be matched by an equal amount from the States, for the construction of rural post roads over a period of five years, and \$10,000,000—\$1,000,000 a year for 10 years—for roads within or partly within the National Forests. It required each State to have a responsible central highway department with the requisite powers and funds. All the States have complied with the terms of the act, although it was necessary for them to enact additional legislation, or to amend their constitutions; to provide sufficient funds to match the Federal apportionment; and to strengthen existing central highway bodies or to create new agencies.

When these preliminary steps had been practically completed and the department and the States were about ready to proceed vigorously with the actual construction of roads, the United States entered the war. It soon became necessary greatly to curtail highway building because of the difficulty of securing transportation, construction materials, and the requisite services. After the armistice was signed, arrangements promptly were made for the active resumption and vigorous prosecution of road work in all sections of the country, not only with a view to repair the damage wrought by the heavy traffic forced upon our highways during the war, when maintenance operations were seriously interfered with, but also to provide adequate transportation facilities to serve the increased needs of agriculture and industry. Recognizing also that road-building activities would furnish suitable employment for many unemployed men during the period of transition from war to peace, the Congress at its last session, accepting the recommenda-

tion of the Department of Agriculture, appropriated \$209,000,000, in addition to the \$85,000,000 provided by the original act, for the extension of road construction in co-operation with the States, and also made some important amendments to the act. The definition of the kind of roads that can be constructed was greatly broadened and the limitation on the Federal contribution for any one road was increased from \$10,000 to \$20,000 a mile. These amendments have greatly facilitated consideration of and action upon the road projects submitted by the State highway commissions. There is now no special obstacle to the construction, in the different States of the Union, of the roads which serve the greatest economic needs.

#### TRoublesome Limitations Removed.

The act, as amended, places only three limitations on the type of road which may be built, as follows:

(1) That the roads shall be "substantial in character." This means that the road must be so constructed that it will carry the prospective traffic with such maintenance expenses that the total annual charges will represent a reasonable expenditure for the public service rendered by the highway. It is to the interest of the States that the roads on which Federal funds are used be substantially constructed, because the law requires them, or their civil subdivisions, as a prerequisite to receiving further funds, to maintain properly all roads built with Federal aid. There is nothing in the law which restricts types of construction between narrower limits than those established by sound finance and good engineering practice.

(2) That the amount contributed from the Federal Treasury in connection with any road shall not exceed 50 per cent of its cost or \$20,000 a mile. The main thing is to build a road that will stand the traffic in the particular section of the country where it is constructed. The conditions in certain regions may require a heavy, comparatively

high-cost type of road, while in others a lower cost type may meet all the requirements. Sentiment is growing throughout the country, even in the newer sections, in favor of more substantial roads. The people are beginning to realize that the expense of maintaining the lighter traffic types under heavy traffic is unbearable.

(3) That the road must be a "rural post road" as defined in the act as amended; that is, "any public road a major portion of which is now used, or can be used, or forms a connecting link not to exceed 10 miles in length of any road or roads now or hereafter used for the transportation of the United States mails." Under the original wording of the law, Federal funds could be expended only on roads upon which the United States mails "now are or may hereafter be transported." This feature was the most troublesome to the highway departments of the various States. It required a definite determination in each case of the actual post-route status of the road, which necessarily involved delays in many instances. Under the new definition, very few important roads, if any, will be debarred from receiving Federal aid, if all the other requirements of the act are met.

Following the amendments to the act, the regulations governing its administration and the standards for plans, specifications, and estimates were modified, and one of the most successful former State highway engineers in the country was placed in charge of the Federal aid road work. He has at his disposal a large staff of local and district engineer aids, and no pains will be spared to provide any further Federal assistance that may be needed. An advisory committee, composed of representatives of the State highway departments, selected at the request of the department, by the American Association of State Highway Officials, with due regard to geographic considerations, also has been appointed to work in intimate touch with the Federal bureau, meeting with its officers at stated periods and at such other times as may seem desirable.

## LARGE RESULTS FROM PRESENT FEDERAL LAW.

The record indicates that from July 1, 1918, to November 1, 1919, the department approved 1,345 road projects, involving the improvement of 12,159 miles, at an estimated cost of approximately \$181,143,644. Of this sum, approximately \$78,592,167 represents Federal funds. Since the passage of the Federal aid road act, 1,927 projects have been approved. These call for the construction of 18,596 miles of road at an estimated cost of \$225,267,847, of which about \$95,498,140 will be borne by the Federal Government. Gratifying progress also has been made in connection with the National Forest road work. From July 1, 1918, to November 1, 1919, 74 projects, involving 923 miles of road, were approved, and plans were completed for the improvement of 50 others, aggregating 946 miles.

The 1919 program for Federal aid road building is greater than any previous annual road-building accomplishment in this country. It is so great, in fact, that it undoubtedly will be necessary for many of the States to postpone until 1920 the expenditure of the Federal funds because of the necessity of developing experienced contracting and engineering organizations from the stagnant conditions brought about by the war. Under the terms of the act, the apportionment to a State for any one fiscal year remains available for expenditure until the close of the succeeding year. It is estimated that the funds already provided will be sufficient to finance next year a program more than four times greater than any that has ever been undertaken. As indicated, \$294,000,000 has been made available from the Federal Treasury, and it is roughly estimated that the State funds to be expended cooperatively on road projects under the terms of the Federal act will aggregate \$385,000,000.

It is also true that some States will expend large sums in excess of those to be used on cooperative projects and that their several subdivisions will provide large additional



amounts. It is interesting to note that up to July 1, 1919, State bond issues aggregating \$224,800,000 had been authorized and approved by popular vote and that provision has been made for voting next year on proposals for the issuance of additional State road bonds to the extent of approximately \$314,000,000. During the present and the next fiscal year, there will be made available for road improvements at least \$1,000,000,000. Certainly, few laws, if any, have produced greater results, either in terms of expenditures for a good purpose or in terms of helpful legislation and machinery, than the Federal aid road act. It seems clear, in the circumstances, that the principal limiting factors in the 1920 program will be those of rail transportation for, and production of, suitable road materials, the contractors' organizations available, and the labor supply.

NO ADDITIONAL ADMINISTRATIVE MACHINERY NEEDED.

The suggestion has been made that the Federal supervision of highways should be taken from the Department of Agriculture and placed under a Federal highway commission. A bill having this purpose in view has been introduced in the Senate of the United States. It provides for a Federal highway commission of three, each receiving a salary of \$10,000 a year, whose duty, among other things, would be to establish, improve, repair, and maintain a system of highways "to comprise not less than 2 per cent nor more than 5 per cent of the total highway mileage actually used as such in any State as ascertained by the commission hereinafter provided for, nor less than 2 per cent nor more than 4 per cent of the total highway mileage actually used as such in all of the States as ascertained by the commission, and affording convenient ingress to and egress from each State at not less than three points and connecting with highways forming part of the national highway system in adjoining States." The commission is given the power to select or establish the highways to be comprised in the sys-

tem, after having requested the State highway departments to recommend routes, and to determine the order in which all or parts of such highways shall be constructed, reconstructed, improved, repaired, and maintained. The Federal Government is to assume the maintenance of these roads. The commission is furthermore empowered to take over the work of the Department of Agriculture relating to highway transportation, to construct and maintain buildings outside the District of Columbia, to operate housing and subsistence facilities and commissary stores for the benefit of its employees and others engaged on work under its direction, and to purchase, lease, operate, and maintain such motor and other transportation facilities as it may deem necessary in the performance of its duties.

In considering any proposal of this sort, certain fundamental considerations must be borne in mind: (1) The roads in each section of the country are of varying degrees of importance in the service which they render or may render to the particular locality, to the State, and to the Nation as a whole; (2) this is a big country and the traffic conditions and needs vary greatly from section to section; (3) the State highway departments, being in immediate touch with local conditions, are best able to classify the roads properly on the basis of the economic purpose which they may serve; (4) the Federal Government, under the Federal aid road act, is cooperating in the improvement of the roads of greatest importance, the classification of which is fixed by the State highway departments; and (5) when this classification has been carefully made and by agreement between the highway departments of adjoining States, the roads of first importance generally meet at State boundaries, and, therefore, become interstate highways of nation-wide utility. The Federal Government under the present law is aiding the State highway departments in the classification of their roads on the basis of importance and needs, and Federal aid

is rapidly being extended for their improvement, on projects submitted by the States and approved by this department.

The present machinery for supervising road construction is the Federal Bureau of Public Roads, one of the two most efficient agencies of the kind in the world, and the 48 State highway commissions. These, in effect, constitute an expert national commission, intimately in touch through its various parts with all sections of the Union, having no other purpose than that of serving the public interest. It is difficult to see what need there can be for additional or new machinery. Certainly, there is no necessity of creating a separate Federal highway commission or of substituting for the present cooperative program a plan which would commit or limit expenditure to a federally owned and maintained highway system. Such a plan would not meet present needs. There is as yet too much pioneer work required to trust the working out of proper highway policies to a small Federal commission.

Very properly the Federal aid road act places on the highway authorities of the several States responsibility, in large measure, for selecting the roads to be constructed. Obviously the local authorities are in a better position to judge what roads would serve the largest economic needs than any group of men sitting in Washington would be. It is the duty of the Federal Bureau of Roads, with its district engineers, to see that the provisions of the law are complied with. It is giving, and will continue to give, all possible assistance to the State authorities in all their technical problems, as well as in the planning of State systems and in the classification of roads. It has been the policy of the department from the outset, in order to prevent haphazard action, to have the State highway authorities prepare and present tentative State systems of roads. It was apparent that rigid systems not subject to modifications as conditions might require would be inadvisable. Each State has worked out a system and, in general, it is being followed in

the development of projects and the construction of roads. In a number of instances systems in general terms have been adopted by the legislatures. In formulating these systems, the engineers are giving due regard to interstate connections, that is, to roads connecting the system of one State with that of another, and as progress is made the construction of through roads will follow as a matter of course.

PROPOSED CHANGE WOULD MEAN LOSS.

I am convinced that nothing material would be gained by the proposed change. Much would be lost. Many complications would be introduced. The creation of a commission would entail unnecessary additional administrative expenditures and the commission could not do anything that can not be done more effectively by the existing cooperative machinery. I think it is not too much to say that there is a minimum of friction in the relations of the State and Federal authorities and that the majority of the State highway agencies are satisfied with the present arrangement and do not wish a change.

There would also be a radical change of policy. I am of the opinion that the people of the States will not be willing to substitute for the present policy of developing road systems on the principle of serving the broadest economic needs that policy advocated by those whose interest is in main or trunk line automobile roads primarily for touring purposes. The largest service will be rendered, not only to farmers but also to urban people, by following the principle of constructing roads of the greatest economic importance, selected after careful consideration by the State agencies having adequate knowledge and approved by the Federal department. It seems to me clear also that, as the work proceeds, we shall have roads which will be equally serviceable not only to those interested immediately in long-distance automobile travel and motor-truck transportation but also to those interested in getting their farm

produce to the market in the easiest and most effective manner and in the transportation of the mails. I clearly recognize the vast growth and importance of the motor-propelled vehicle passenger and freight traffic. It is estimated that we have 87 per cent of all such vehicles in the world, and we are only at the beginning of their use; but I am satisfied that the development of highways along present lines rather than along the lines proposed will result in their more extensive use. I have no prejudice against any sort of road except a bad road, or against any sort of construction except wasteful and unsubstantial construction. If traffic conditions require heavy construction, then I am in favor of it; and in any case, under the present law, the road must be substantial.

The road movement is growing very rapidly. The Federal aid road act has done much to promote it. Experience has brought about amendments to the law and helpful changes in administration. Comprehensive road programs have been inaugurated. They are being pushed vigorously. They will result, in a shorter time than most people imagine, not only in a network of good substantial roads in the various States of the Union, but also in the requisite interstate highways.

Why at this stage introduce complications and embarrassments? Why should not the friends of the movement for roads to serve the people cooperate? It is difficult for me to see why all who are animated by high public spirit in their thinking concerning highways should not cooperate in the development of present programs and in the perfecting of the existing processes and machinery, instead of attempting to overthrow them. I believe that many of those who are backing the proposed change do not know the facts and are not aware of existing conditions and possibilities.

## CONTINUATION OF FEDERAL APPROPRIATIONS.

The period covered by the original Federal aid road act and its amendments will expire with the fiscal year 1921. The results to date clearly point to the desirability of continuing the policy of Federal participation in road building. If this is to be done, it is essential that a decision be reached at an early date, so that the States may be able to make the necessary financial provision and the State and Federal departments make the requisite administrative arrangements. If the financial condition of the Nation permits it, I believe it would be good policy to make available from the Federal Treasury, to be expended under the terms of existing legislation, \$100,000,000 for at least each of the four years beginning with the fiscal year 1922.

## PAST ACTION AND FUTURE STEPS.

The promotion of agriculture and the betterment of rural life have, for many years, received the earnest attention and support of State and Federal authorities. Several generations ago the foundations were laid for the two great agricultural agencies—the land-grant colleges and the Federal Department of Agriculture—which have no rivals elsewhere in the world. The State colleges steadily developed until in 1918 they had plants and endowments valued at \$184,400,000, annual incomes aggregating \$47,700,000, and resident and short-course students numbering 123,000, of whom 45,000 were in agricultural courses. Their student body has greatly increased this year. They are now engaged, in cooperation with the Department of Agriculture, in agricultural extension work involving an annual expenditure of more than \$14,000,000. They have been conducting investigational and educational work for many years and have placed in all parts of the Union farm leaders with scientific and practical vision. The Federal Department of Agriculture, whose personnel now numbers more than 21,000, is expending from all sources during the current year \$41,800,000, aside from the \$294,000,000

made available by the original and amended Federal aid road act for the cooperative construction of roads.

As has been repeatedly pointed out, the last five or six years have been especially fruitful of legislation and administrative action looking to the improvement of production and distribution. The principal items are the following:

(1) The Bureau of Markets, excelling in the character and extent of its activities any other similar existing organization.

(2) The Cooperative Agricultural Extension Act, the object of which is to disseminate information among the farmers, mainly through trained agents. As has been indicated, there is now expended annually, from Federal, State, and local sources, more than \$14,000,000 for work contemplated by this act.

(3) The Cotton Futures Act, with amendments, under the provisions of which standards for cotton have been established, the operations of the futures exchanges supervised, and the sale of cotton put on a firmer basis.

(4) The Grain Standards Act, which aims to bring about uniformity in the grading of grain, enable the farmer to obtain a fairer price for his product, and afford him a financial incentive to raise better grades of grain.

(5) The Warehouse Act, which authorizes the Department of Agriculture to license bonded warehouses and which makes possible the issuance of reliable and easily negotiable warehouse receipts, permits the better storing of farm products, increases the desirability of receipts as collateral for loans, and promotes the standardizing of storages and of marketing processes.

(6) The Federal Aid Road Act, as amended, which made available \$294,000,000 for cooperation between the Federal and State Governments in the construction of rural roads. It has conduced to the establishment of more effective highway machinery in each State and strongly influenced the development of good road building along right lines. It will

stimulate larger production and better marketing, promote a fuller and more attractive rural life, add greatly to the convenience and economic welfare of all the people, and strengthen the national foundations.

(7) The Federal Reserve Act, which authorized national banks to lend money on farm mortgages and recognized the peculiar needs of the farmer by giving his paper a period of maturity of six months.

(8) The Federal Farm Loan Act, which created a banking system reaching intimately into the rural districts and operating on terms suited to the farmer's needs. It is attracting more capital into agricultural operations, bringing about a reduction of interest to farmers, and placing upon the market mortgages which are safe investments for private funds.

(9) The Vocational Education Act, which, among other things, provides for cooperation with the States in training teachers of agriculture and in giving agricultural instruction to pupils in secondary schools.

Among other steps which should be taken are the following:

(1) The building up, primarily under State law, of a system of personal credit unions, especially for the benefit of farmers whose financial status and scale of operations make it difficult for them to secure accommodations through the ordinary channels.

(2) Expansion of existing facilities and activities for aiding farmers in marketing, including especially the extension of the market news and food-products inspection services and the assignment of trained market specialists to each State, in cooperation with the State authorities, to stimulate cooperative enterprises, and to make helpful suggestions as to plans and methods.

(3) Continuation of the present policy of Federal participation in road building, through the appropriation, if the financial condition of the Nation permits it, of \$100,000,000 for at least each of the four years beginning



with the fiscal year 1922, to be expended under the terms of existing legislation.

(4) The regulation and control of stockyards and packing houses.

(5) Federal legislation further to protect consumers against misbranded, adulterated, and worthless feeds entering into interstate commerce.

(6) Similar legislation dealing with fertilizers.

(7) Increased support by States for rural schools and more definite direction of their instruction along lines related to rural problems and conditions.

(8) The requisite legislation for the improvement of the sanitary conditions in rural districts and for the building up of the needed hospital and medical facilities.

#### NEED FOR BROAD SURVEY OF RURAL CONDITIONS.

Present conditions, and particularly present states of mind, indicate the need of a fresh, broad survey of rural life, of its special problems, and of its relationships. It should be viewed as a whole. A comprehensive flexible program should be developed for the guidance of the different agencies, each of which has its peculiar functions and responsibilities. Furthermore, the principles and purposes governing agricultural life and agencies should be set forth for the education of the American public, particularly the urban part of it. The Nation as a whole needs a fuller appreciation of its basic industry, and a more definite sense of direction of its efforts to foster it. Many agencies are now following more or less well defined, helpful plans of their own devising, but these are at best piecemeal, and there is confusion of leadership and objectives. A program made by any one element would be partial and unsatisfactory. We should have a meeting of minds of all those directly concerned, of farmers, of agricultural leaders, and of business men.

You have already indicated your intention to call a conference at which there will be not only a generous representation of farmers but also of agricultural agencies and organizations and of business interests which have an intimate relation to farm problems. I believe that, because of changed conditions here and elsewhere, of existing uncertainties, and of disturbed states of mind, this conference should be called at the earliest possible date. It may be that, as one outcome of it, the creation of a rural life commission, with a temporary or a permanent status, will be determined to be in the public interest. Certainly, the best means of fostering our basic industry can not too frequently receive definite consideration by the best minds of the Nation.

Respectfully,

D. F. HOUSTON,  
*Secretary of Agriculture.*

The PRESIDENT.

# PREWAR CROP ESTIMATES IN GERMANY

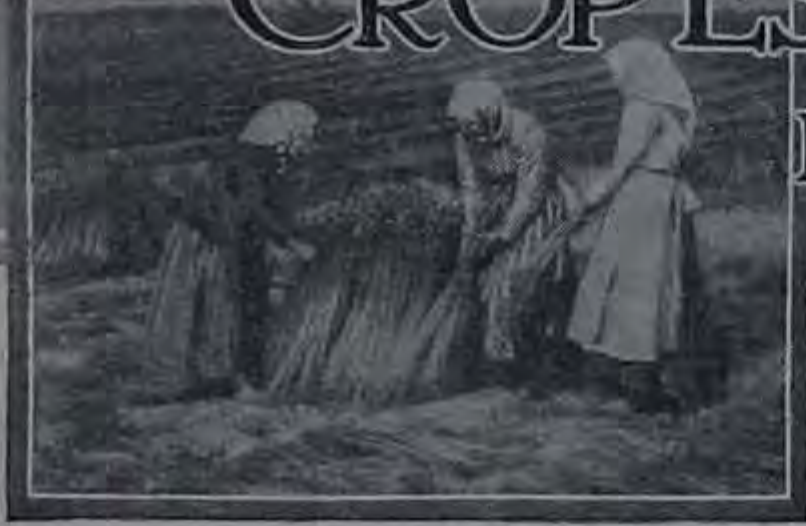

By ALONZO ENGLEBERT TAYLOR,  
*Assistant to the Secretary of Agriculture.*

IN 1878 the German Government introduced a method of estimating the crops of grain, potatoes, and roots based upon personal reports by communal authorities familiar with local conditions. The estimates were founded upon the peasants' statements of acreage, to which experience of yields was applied. In 1893, a second procedure was introduced. Preliminary forecasts were made by agricultural experts connected with the Government, and the final estimates were made as before by communal authorities. This was done because it was alleged by the central governments that the estimates of the local crop reporters were too low and presented a depreciative picture of agriculture in the Empire. The motive for lower estimates was reputed to lie in the landholder's desire to reduce taxes. It was during this time, under the régime of Caprivi, that the Bund der Landwirte was organized. This association became a strong political power and was able to unseat Caprivi. The Bund der Landwirte, as leader of the Agrarian Party in Germany, was allied to the Military and Conservative Parties in all policies and has been consistently Pan-Germanic ever since. It demanded and secured a high tariff on agricultural products and tried in every way to hinder importation of foodstuffs, in order to conserve to the landowners a monopoly of the market of Germany. Naturally this brought the Agrarians into conflict with the Social Democratic Party, which attempted to secure cheaper foodstuffs by importation. The political policy of the Agrarians, usually identified with the Centrum, was to make Germany independent in national subsistence and especially for the eventuality of future war. Under this policy everything was done to stimulate agriculture in efficiency and in profits.

During the years 1893-1898 the reports of the States were always higher than those of the communal authorities. The figures of the agricultural experts ran from 12 to 20 per cent higher than those of the communal authorities. In 1899 the reporting of crops by the local authorities was discontinued and the exclusive function placed in central offices.

When one compares the figures for yield of bread grains and potatoes in a series of years before and during the war, one obtains the following table, in rounded figures, the figures in brackets representing the amounts accounted for in the distribution of the Food Administration:

*Bread grains and potatoes in Germany.*

Year.	Bread grains: Wheat and rye.	Potatoes.
	<i>Tons.</i>	<i>Tons.</i>
1911.....	15,310,000	35,600,000
1912.....	15,800,000	50,300,000
1913.....	16,720,000	54,300,000
1914.....	14,800,000	45,700,000
1915.....	12,870,000	55,100,000
1916.....	11,160,000	23,530,000
	(9,650,000)	(20,580,000)
1917.....	8,970,000	33,820,000
	(8,270,000)	(30,860,000)
1918.....	10,320,000	26,410,000
1919.....	10,810,000	27,000,000

The average of bread-grain yields in 1911, 1912, 1913, 1914, and 1915 was 15,100,000 tons. The average of 1916, 1917, 1918, and 1919 was 10,360,000 tons, or 68 per cent of the previous average. The average of potato yields in 1911, 1912, 1913, 1914, and 1915 was 48,200,000 tons. The average of 1916, 1917, 1918, and 1919 was 27,760,000 tons, or 57 per cent of the previous average. On the basis of obvious but superficial considerations alone, these reductions might be regarded as the results of scarcity of fertilizer, work animals and farm labor and lack of rotation and diversification. This was, indeed, the interpretation commonly advanced in the German press. (Similar reductions in yield were reported for the other grains and for the root crops, but a discussion is best confined to bread grains and potatoes.)

The experiences of the departments entrusted with the control and distribution of foodstuffs during the first year

of the war led, however, to an analysis of crop estimates in Germany that necessitated a different conclusion. The official crop estimates were the foundation of the report of the Eltzbacher Commission (*Die Deutsche Volksernaehrung und der englische Aushungerungsplan*, 1915). According to this report, the then present and prospective supplies of breadstuffs in Germany were such as to cause little concern, rather the contrary. The carry-over from 1913 was stated to be at least 1,500,000 tons. The crop was given as 14,800,000 tons, a total of 16,300,000 tons. Four hundred thousand tons were imported. The figure for the sum of the crop plus carry-over plus import minus the figure for seed (1,500,000 tons) left for consumption during the year 15,200,000 tons. Three million soldiers were fed almost exclusively on grain captured in the occupied areas to the east and west; and some grain and flour were shipped back into Germany. On the first of February an inventory of stocks of breadstuffs was taken and the amount present reported as 4,800,000 tons. Fifteen million two hundred thousand minus 4,800,000 leaves 10,400,000 tons of bread grains that had disappeared during five and a half months, representing a consumption of 1,890,000 tons per month. On bread-cards after February 1, the available 4,800,000 tons provided bread for the same people for seven and a half months, corresponding to a consumption of 640,000 tons per month. On the basis of these figures the Germans were supposed to have consumed breadstuffs in the autumn at the rate of 1,890,000 tons a month and during the following spring and summer months at the rate of 640,000 tons a month. This would correspond to a reduction of two-thirds in the bread ration. The stocks on February 1 should have been in the neighborhood of 10,000,000 tons, if the prewar consumption had occurred. The stocks actually found were 4,800,000 tons. Such a manifestly impossible situation could have had but one or several of five explanations:

The carry-over was exaggerated.

The bread consumption was colossal.

Much bread grain was fed to domesticated animals.

Stocks were concealed.

The crop estimates were greatly exaggerated.

The first really falls under the fifth, since it was a statistical and not an inventoried carry-over.

The failure to find in the inventory of February, 1915, even half of the stocks that statistically should have been in hand, caused a profound sensation in the classes in Germany that were permitted to know the facts. It was clear that the whole structure of the report of the Eltzbacher Commission was undermined, and that the food program of the nation rested on faith rather than on fact. A number of scientists (prominent among them Ballod) thereupon came into the open with the charge that the crop estimates of the empire presented exaggerated figures, as had indeed been previously alleged. Von Braun could find no evidence that the total supplies of bread grain available for the year (crop+carry-over+import) were over 12,400,000 tons, instead of the official 15,200,000 tons. Twelve million four hundred thousand minus 4,800,000 leaves 7,600,000 tons consumed or disappeared in five and one-half months, a figure considerably less than 10,400,000 tons, but still large enough to constitute a puzzle as difficult to the statistician as it was painful to the consumer. No one could pretend that the consumption of bread in the fall of 1914 was greatly above normal. There was much Christmas feasting in Germany in 1914, in anticipation of victory in 1915; but it was not feasting with bread. No evidence could be adduced tending to indicate concealment of material amounts of grain. There remained but two explanations. The crop estimates were glaringly exaggerated; or immense amounts of wheat and rye had been fed to domesticated animals.

The Government felt itself compelled to secure more reliable data, since a rationing could not be programed and established on stocks that did not correspond in bags and bins to the figures on paper. They restored, in 1915, the reporting by communal authorities and indeed doubled this. One forecast was done by the communal authorities just before the harvest; a second estimate was made just after the harvest. The estimates of the agricultural experts of the several States were carried out in November. In 1917 a fourth estimate was added, made late in the fall by experts of the Imperial Grain Department, that had charge of the mobilization of the grain for purposes of distribution according to the program of the military forces and of the food controller. The Imperial Grain Department has

carefully worked over the estimates of the years 1915, 1916, 1917, and 1918, and the result of this survey was expressed in the statement that the most reliable estimate, the one whose figures could be duplicated in actual grain, was the preharvest forecast of the communal authorities. Thus was vindicated, after two decades, the reporting system of the communal authorities discredited in the '90s by Agrarian politicians.

The following specific considerations have been advanced indicating that the estimates of former years were exaggerated.

The prewar consumption of bread and flour in Germany, as determined by milling statistics and study of the habits of the people, was not over 360 pounds of grain per capita per year. The prewar consumption of bread grains was at the rate of something over 900,000 tons per month. Such a higher consumption (520 pounds) as would explain the utilization of the yields of wheat and rye reported during the past 20 years has eluded all detection and has never existed.

The milling statistics leave an enormous gap between grain and flour. In the years 1908-1910 the crops of wheat and rye were given as 30,550,000 tons. The import was 5,090,000 tons; the export 1,970,000 tons. Three million tons were subtracted for seed. That left as supply 30,670,000 tons, regarding the carry-over from 1907 and into 1910 as a stand-off. During those two years the mills ground 21,860,000 tons, leaving unaccounted for 8,810,000 tons, or 29 per cent. In the year 1912-13, 10,930,000 tons passed through the mills. The demonstrable utilization of wheat in this country, as pointed out to the German Government by Ballod in 1915, accounts for 97 per cent of the crop figure for wheat.

In 1907 the German Government carried out a special survey of acreage under cultivation, an actual piece-by-piece count and estimate. This yielded the figure 24,900,000 hectares. The figure for the same year for cultivated acreage used for basis of crop reports was 26,100,000 hectares. A tabulation carried out in 1915 again gave results materially lower than those used by the crop reporters. A card index system is now in use.

France clung to the old method of communal crop reporting. Contrasting the progress of growing of grain during the last decades, we find that in France the acreage has fallen, from 1880 to 1913, from 14,200,000 to 13,800,000 hectares, while the yield has increased from 15,200,000 to 16,966,000 tons, a gain of 15 per cent. In Germany the acreage has increased from 13,500,000 to 14,400,000 hectares, while the yield has increased from 14,030,000 to 27,330,000 tons, a gain of 82 per cent. With all appreciation for German agriculture the increase is so large as to awaken distrust. Statistical grain has always been tangible in France but not tangible in Germany.

In Germany a ton of phosphate was supposed to increase the yield of grain 5 tons, of potatoes 8 tons. In France the increase in yield per ton of phosphate was reported as 1 ton for grain and 2.5 tons for potatoes. The contrast again awakens distrust.

The official explanation first given for the disappearance of wheat and rye in 1914 ran to the effect that it had been fed to domesticated animals. There was without question some feeding to animals, because the customary supply of barley from Russia was wanting. But the amount was much more than could be thus accounted for; and in any event this explanation can not avail, because the dilemma of the statistical hiatus was the same before the war. Up to 1906 it might have been assumed that material amounts of wheat and rye outside of the tailings (the tailings of rye were commonly stated to constitute 10 per cent of the crop) were fed to swine because of price relations. But in 1906 the import duty on barley was lowered to 13 marks per ton and that on rye raised to 50 marks per ton. The result was to create disparity between the prices of rye and barley and stimulate the growing of rye. During the five years before the war the mean price of barley was some 25 to 30 per cent below that of rye. As a result Germany became a rye-exporting and barley-importing state. It is folly to assume that between 1906 and 1914 the peasant fed high-priced rye to swine and sold cheap barley. The normal import of feed barley and maize before the war was not over 350,000 tons per month; but during the fall months of 1914 the grain that disappeared was almost three times that amount. The discrepancy in the figures existed before 1906. It continued



from that date until the onset of the war. It persisted until the introduction of a different method of crop reporting. Only one explanation remains: The crop yields were exaggerated.

What has been said of rye applies to wheat with still greater force. The milling statistics are kept separate for wheat and rye. According to the statistics for crop, import, and milling of wheat in the two years 1908-9 and 1909-10, 3,600,000 tons of wheat remained unaccounted for. To state that Germany raised and imported wheat to feed to domesticated animals in any volume, beyond the tailings, is absurd.

It is the general view now stated in official and scientific journals that the prewar reports of grain yields were at least 10, possibly at times 15, per cent too high. In a memorandum presented by the Food Administration of the present German Government to the American Relief Administration occur the following words: "The November estimate of the Imperial Statistical Bureau was in peace times demonstrably much too high."

What has been stated for wheat and rye holds in like manner for barley, oats, and the fodder roots. When the imported feeding stuffs were no longer available, the peasants found that they did not possess over 85 to 90 per cent of the feed grains that statistically they were supposed to possess. The army requisitions of feed grains were based on the crop reports. Thus the peasants' stocks were contracted from both directions.

The situation is statistically not so clear for potatoes, but it is agreed that the prewar figures for the potato crop must have been 15 per cent too high. The following table contains rounded figures for the average crops and utilization:

*Average crops and utilization of potatoes in Germany.*

Use.	Average of 1911, 1912, 1913, 1914, and 1915.	Average of 1916, 1917, and 1918.
	<i>Tons.</i>	<i>Tons.</i>
Crop.....	48,200,000	27,900,000
Seed and waste.....	10,000,000	7,200,000
Industry.....	5,000,000	2,300,000
Human food.....	14,000,000	14,100,000
Animal feed.....	19,000,000	4,400,000

When one compares the data in this table and recalls the enormous amounts of concentrates that Germany used to import (barley, maize, oil seeds, oil cake, mill feed), it is clear that the figure representing the exaggeration in the crop report must lie largely in the amount recorded as devoted to domesticated animals. The elucidation now usually advanced in Germany to explain the exaggerated figures is that the experts of the agricultural departments of the several States, accustomed to operations on efficient estates, judged all productions per hectare by those to which they were accustomed. The Socialists, however, are not disposed to deny that the figures were padded for political purposes, in order to bolster up the program of the Agrarian party.

In foreign nations the revelation that the German crop reports have been exaggerated for nearly a quarter of a century will arouse two reflections. To the scientifically minded the statistical confusion that has been introduced through the use of the official German figures is appalling. To the practical farmer, however, as well as to the student of agriculture, the reflection will linger that it was upon these exaggerated crop reports that German propaganda for potash was largely based.

# PROGRESS *in* ERADICATING CONTAGIOUS ANIMAL DISEASES

By JOHN R. MOHLER,  
*Chief, Bureau of Animal Industry.*

COMBATING animal disease is a struggle against unseen enemies. Their attacks are felt in live-stock losses, and even when results are not fatal to animals there is nearly always a setback in production, growth, vitality, or all of these combined.

So swift and persistent are the attacks of many contagious diseases that after the appearance of visible symptoms little can be done to save the infected animals. The owner of such stock is stout-hearted indeed if he accepts his reverses and endeavors to recoup the loss in the face of dangers from similar attacks. Most live-stock men are courageous, accustomed to take risks, and ready to grapple with problems as they arise. But without the assistance of various weapons of science developed during the last few decades, farmers and stockmen would necessarily be on the defensive continuously. They would pay toll to one disease or another in the futile hope that each loss would be the last.

## SCIENCE MAKES AGGRESSIVE ACTION POSSIBLE.

Fortunately, veterinary science, based on experimental work and research, has reversed the nature of the contest. A knowledge of methods of combating the unseen foe enables sanitary officials and persons engaged in the live-stock industry to take the aggressive. Public opinion on the control of these diseases also has given added impetus to the work.

Stockmen familiar with the trend of the industry know that as herds and flocks increase to meet human requirements, the control of disease becomes a greater problem. More than that, the tendency toward an increased number

of live stock throughout the country introduces a danger of infection much greater than when interchange of animals was mostly local. Congress and most State legislatures have supported disease-control work in a tangible way by voting funds for conducting systematic campaigns of eradication. Bureau of Animal Industry records and reports from States furnish evidence of encouraging progress in the work; and the results point to the value of handling problems in disease eradication on a Nation-wide scale wherever possible. There are several reasons.

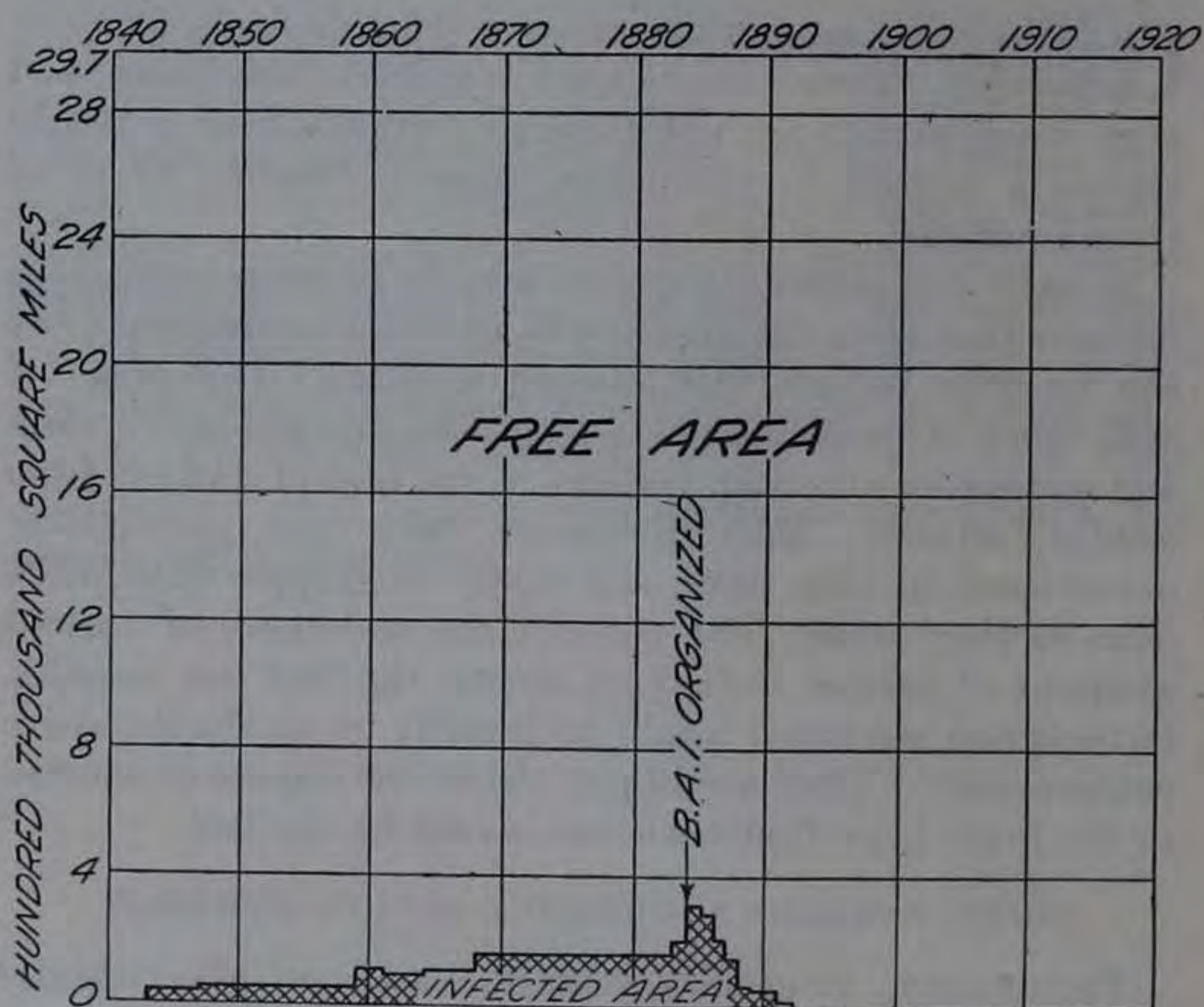

Eradication of Contagious Pleuropneumonia.

The disease had existed ever since 1843. Eradication was begun in 1884 and completed in 1893.

While inspection and regulation are valuable safeguards in checking the spread of infectious diseases, the most satisfactory solution is eradication from the entire country, followed by suitable methods of preventing reinfection. In the case of some diseases, such as hog cholera, in which the source of infection is often very difficult to trace, complete eradication is a baffling problem. There is now being

waged, however, a series of aggressive country-wide campaigns against the most important live-stock diseases, with a view to their ultimate wiping out.

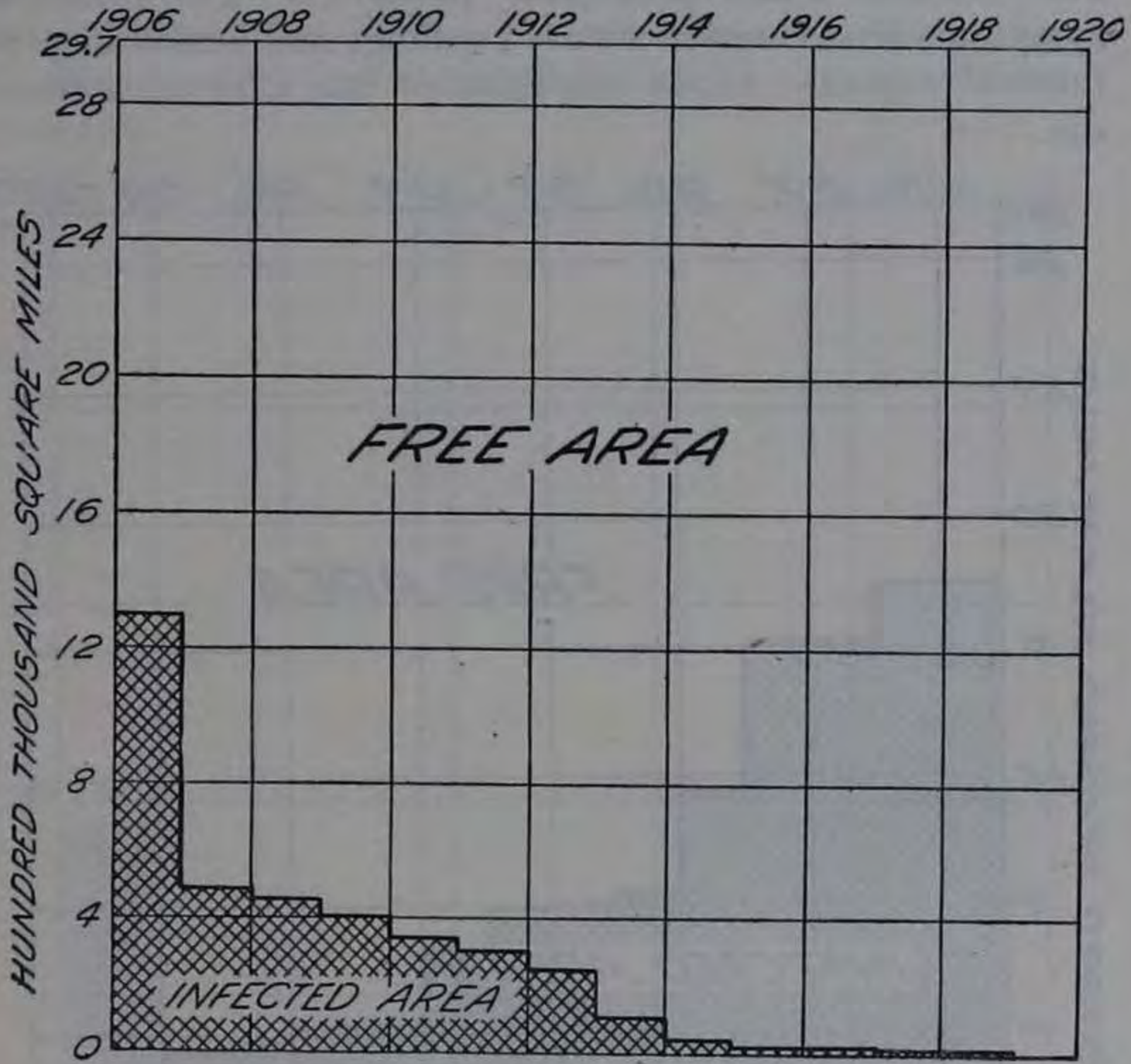

Eradication of Cattle Scabies.

Nearly one-half of the United States was affected in 1906. Eradication is nearly completed.

PROGRESS SHOWN IN CHARTS.

The accompanying charts give live-stock owners a comprehensive knowledge of progress in disease eradication. Based on official records covering a term of years, these charts show clearly that disease control and eradication are not hopeless tasks. Following is a brief statement regarding the prevalence or absence of the more important animal diseases in the United States and in the world at the end of the fiscal year which closed June 30, 1919.

## CONTAGIOUS ANIMAL DISEASES FROM WHICH THE UNITED STATES IS ENTIRELY FREE.

*African horse sickness.*—As the name indicates, this is a horse disease found principally in Africa. The principal symptoms are extensive watery swellings and hemorrhage of internal organs. About one-third of the affected animals die.

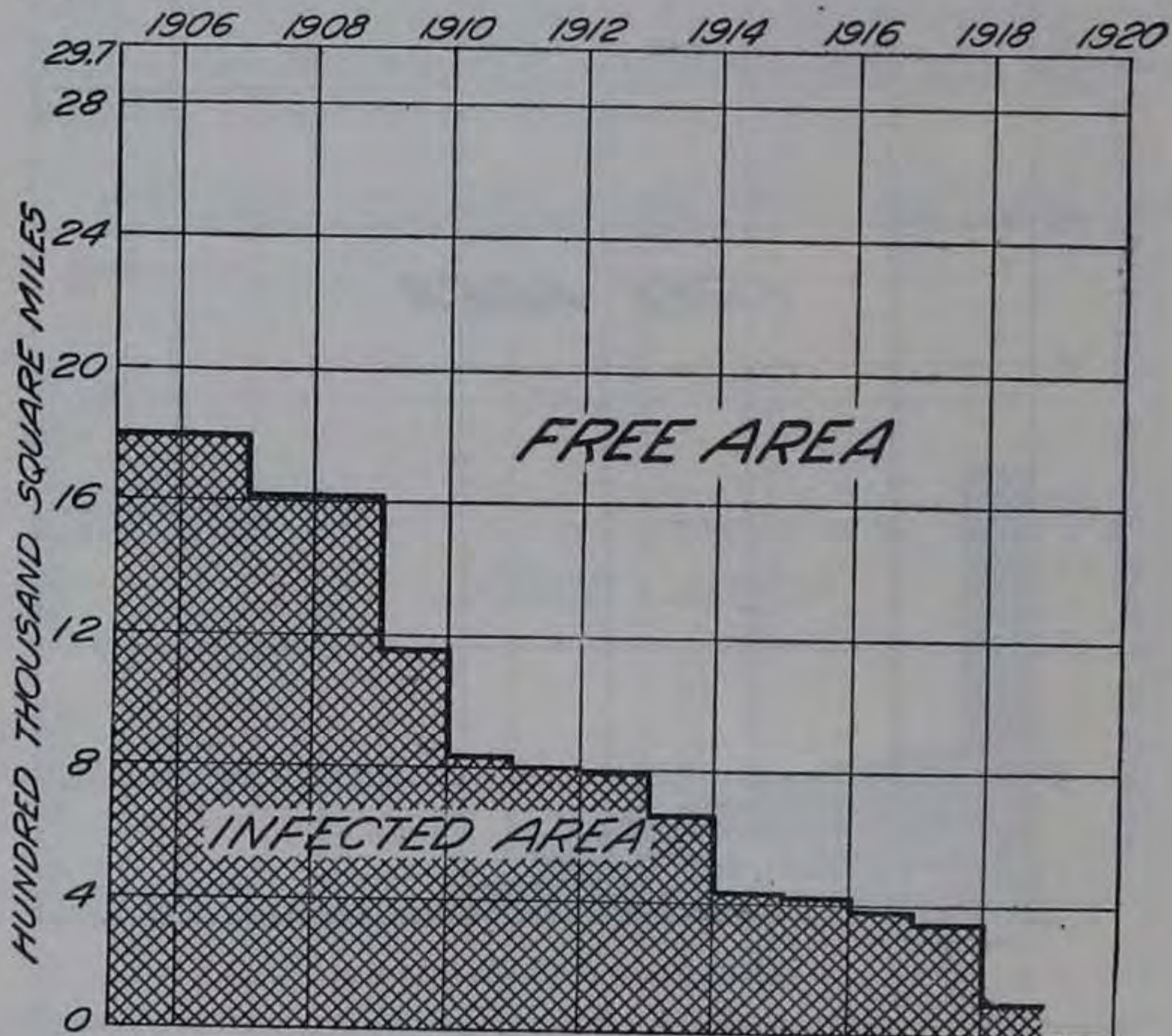

Eradication of Sheep Scabies.

The task of freeing the United States from this disease is more than nine-tenths complete.

*Foot-and-mouth disease.*—This is a highly infectious disease affecting cattle and swine principally, but also attacking other animals and even people. The principal symptoms are blisters on the feet, mouth, and teats, a feverish condition, and (in dairy cows) caked udders. When internal organs are affected, which is particularly the case with calves, the disease usually is fatal.

*Lymphangitis (ulcerative and epizootic).*—These two forms of lymphangitis, caused by two different organisms, are very contagious and hard to cure. Although absent from the

United States, they have been a veritable menace since the war, owing to their prevalence among the horses used in the war areas of Europe. Special regulations were issued governing the inspection and quarantine of horses entering the United States from Europe. These appear to have been effective thus far in preventing these infections from reaching our shores.

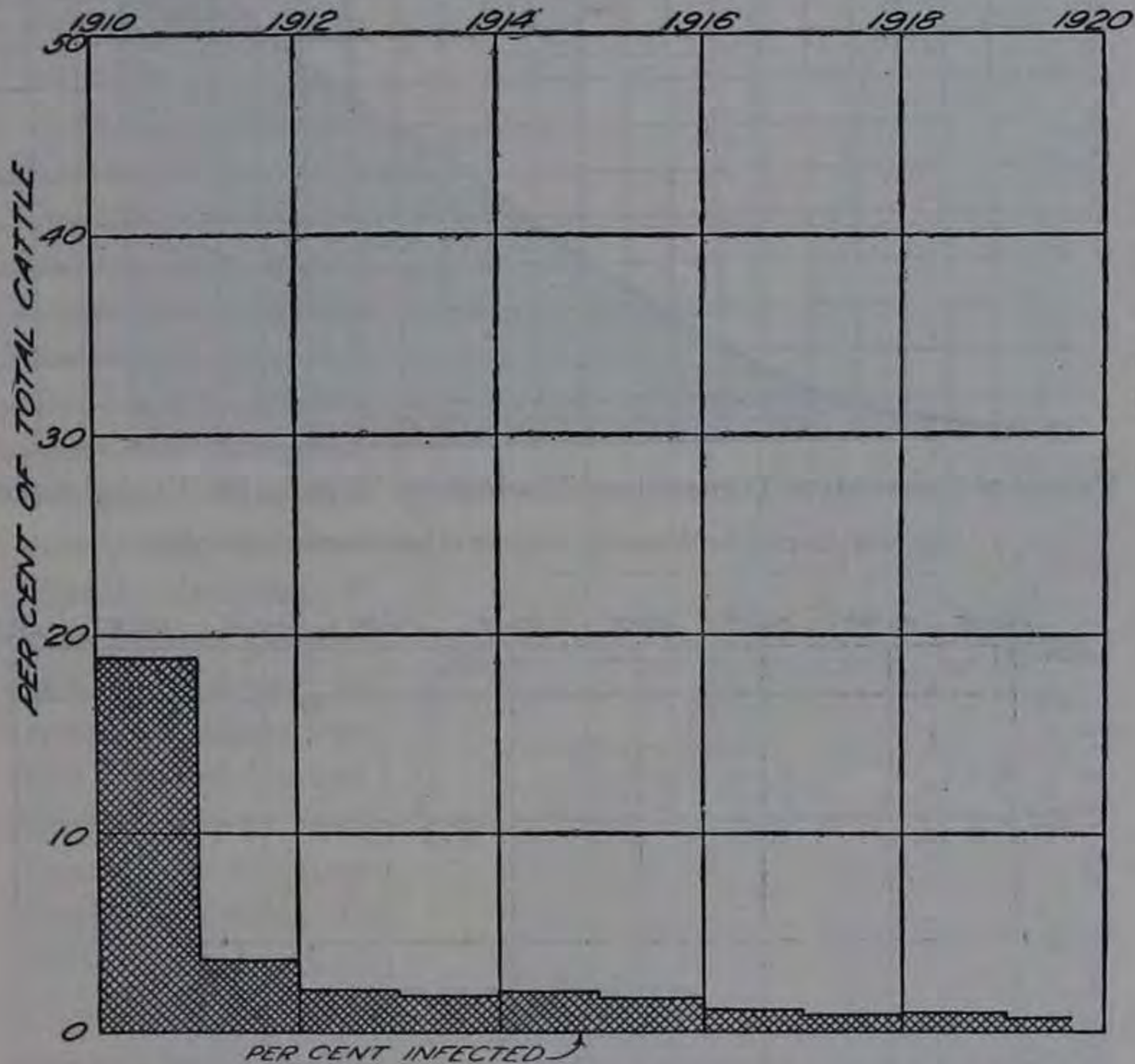

Eradication of Bovine Tuberculosis in District of Columbia.

The per cent of tuberculous cattle has been reduced from about 19 per cent in 1910, when the work began, to 0.63 per cent in 1919.

*Mal de Caderas.*—This disease affects horses principally, producing a weakness of the hind parts, with staggering gait and finally paralysis. *Mal de Caderas* exists chiefly in the northern and central portions of South America, and in certain districts of Brazil it has caused the complete annihilation of the horse stock.

*Cattle farcy.*—This is a chronic disease of cattle occurring in France and the West Indies. It is characterized by nodular swellings in the skin, which spread to the glands and finally

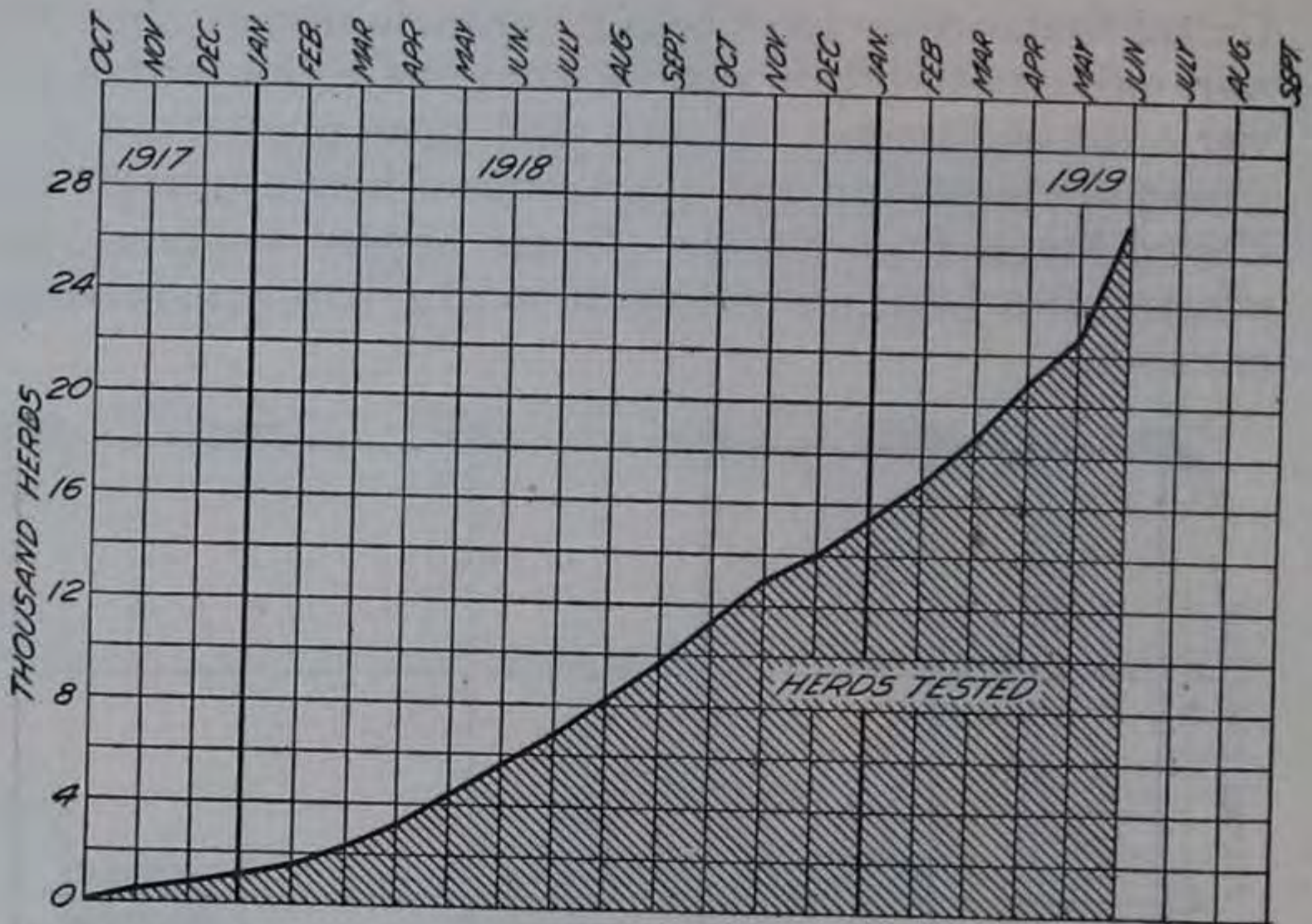

Extent of Cooperative Tuberculosis-Eradication Work in the United States.

The chart shows the increasing number of herds under supervision.

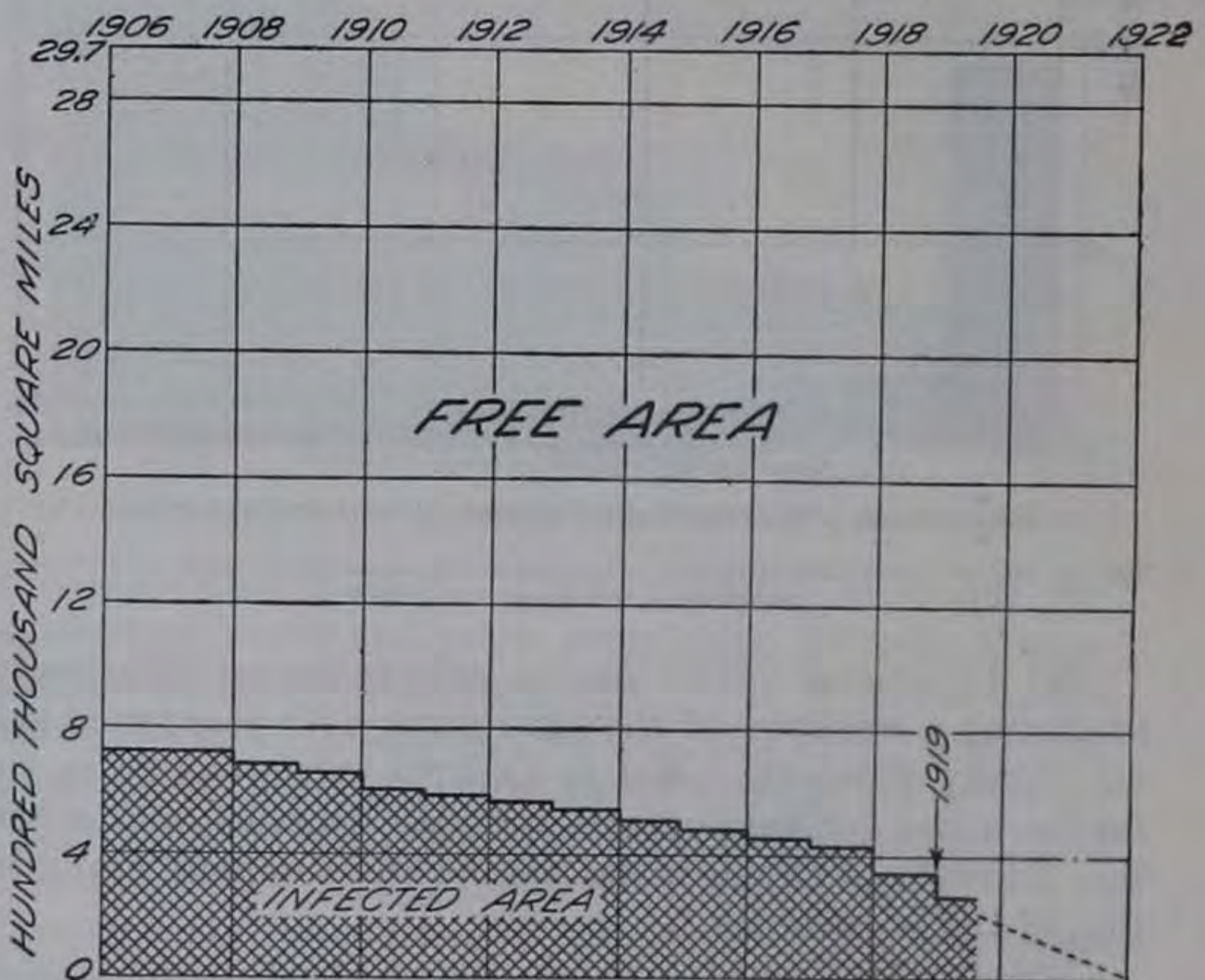

Eradication of Cattle Ticks.

Every year since 1906 has shown progress.



the viscera, proving fatal within a year. While resembling the farcy of horses, it is caused by an entirely different germ and should not be confused with the external skin form of glanders. Fortunately, it has never been introduced into this country.

*Malta fever.*—Malta fever is a disease of goats, and has been found occasionally in the southern part of the United States near the Mexican border. The disease is serious principally because it also affects people. Malta fever is scarcely known in the United States, though it was found at a quarantine station in 1905 in a herd of goats which were imported from the Island of Malta and entered at the port of New York. The disease was stamped out in quarantine.

In 1912 it had gained some headway when discovered in goats near the Mexican border. In this instance the disease was introduced in goats imported from Mexico. By means of vigorous quarantine methods it was

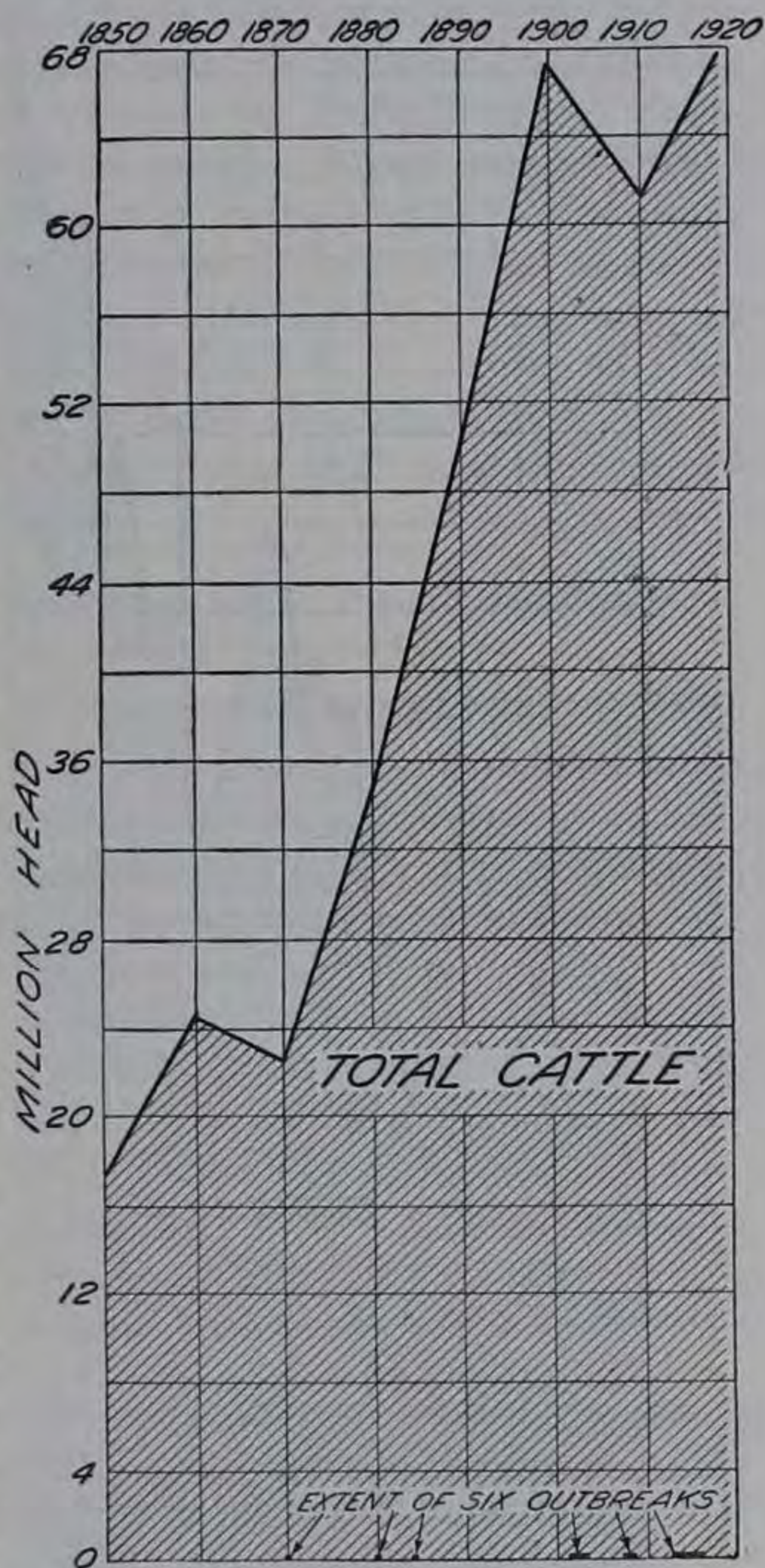

Suppression of Foot-and-Mouth Disease.

In 1870, 1880, and 1884 only a few head were infected; in 1902, 4,712 were infected; in 1908-9, 2,025; and in 1914-1916, 77,240 were slaughtered. The United States is now free from the disease.

In this instance the disease was introduced in goats imported from Mexico. By means of vigorous quarantine methods it was

confined to limited areas of the Southwest adjacent to the Mexican border and eradicated.

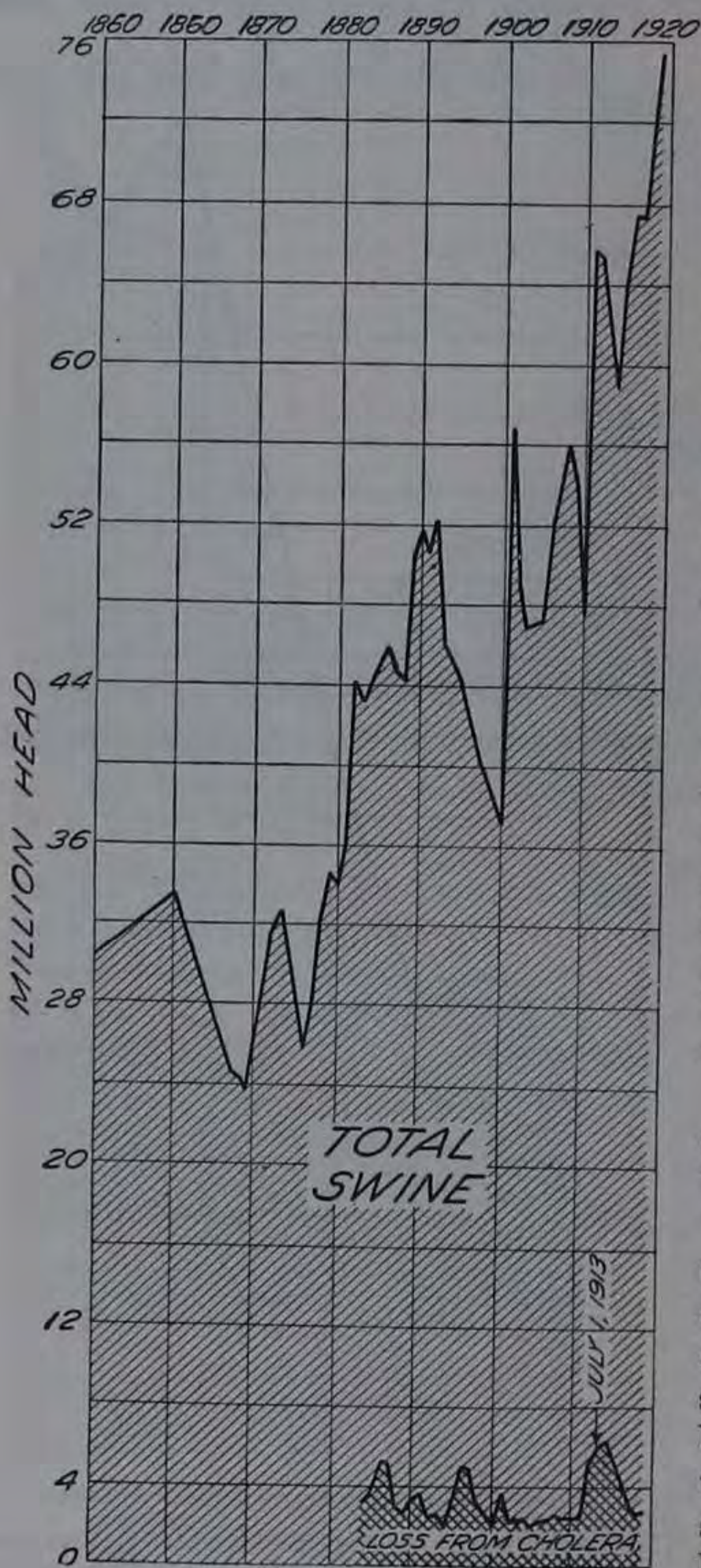

Extent of Hog-Cholera Losses.

Immunization by serum prevents recurrence of serious outbreaks of the past.

acute, infectious disease attacks the bovine species, causing heavy losses. The digestive organs mainly are involved. Rinderpest exacts a heavy toll among cattle in Russia, South

*Nagana.*—This scourge is caused by the bite of the tsetse fly and generally is fatal. It is more prevalent in the central and southern parts of Africa, where on occasion it has annihilated the cattle of entire districts and has affected horses and other animals also. Therefore, nagana is one of the most destructive of animal diseases. It is excluded from the United States by quarantine methods.

*Pleuropneumonia or lung plague.*—This highly contagious disease causes heavy losses among the bovine species. It was stamped out of the United States in the early nineties and ever since has been excluded.

*Rinderpest.*—Sometimes called cattle plague, this

Africa, Asia, and the Philippines, but has never reached this country.

*Surra.*—This scourge is a fever affecting principally horses, asses, and mules. It causes watery swellings and is usually fatal. The disease is common in the Philippines and India. No satisfactory treatment is known. Surra has never been known to exist among live stock in the United States and is excluded through rigid quarantine. In 1906 one outbreak was halted at a Federal quarantine station where imported Indian cattle showing the infection had been received. All the infected animals were promptly slaughtered and burned, while the remainder of the herd was kept carefully isolated until all danger had passed.

CONTAGIOUS ANIMAL DISEASES FROM WHICH THE UNITED STATES IS RELATIVELY FREE.

*Anthrax.*—Anthrax now exists in the United States chiefly in isolated cases. It may be prevented with certainty by the vaccination of susceptible animals with anthrax vaccines.

*Blackleg.*—Blackleg is a disease affecting calves principally, and may be prevented by vaccination with blackleg vaccines.

*Dourine.*—Dourine, a disease affecting the reproductive organs of horses, exists to a limited extent principally among the animals of Indian reservations in New Mexico and Arizona. Eradication work is limited by the fact that most of the animals affected are wild ponies. The disease has only occasionally been found among horses on farms and it was then confined to a few farms in four or five Western States.

*Glanders.*—This disease, which affects horses and mules, is readily detected by several tests and is now under reasonably effective control. Either the blood test or the mallein test may be used.

IMPORTANT CONTAGIOUS DISEASES NOW BEING CONTROLLED.

The principal diseases now affecting live stock in the United States and which are a serious menace to the industry are hog cholera, tuberculosis, Texas or tick fever, contagious abortion, cattle scab, and sheep scab. Nationwide efforts against all these diseases have been in progress for a number of years, with the results shown in the charts.

Cattle scab and sheep scab have been eradicated almost entirely from the country at large, although these diseases are still serious in limited areas. Eradication of cattle ticks, which cause tick fever, appears likely to be completed about 1923.

Hog cholera may be controlled with assurance by the use of anti-hog-cholera serum inoculated simultaneously with hog-cholera virus.

Tuberculosis in live stock may be detected with reasonable certainty by the proper application of the tuberculin test. There are three principal tuberculin tests—the subcutaneous, the intradermal, and the ophthalmic—which may be used alone or together.

Contagious abortion is best controlled by sanitary measures, when combined with proper herd management, and each year recently has added to a knowledge of the best methods for preventing the spread of this disease.

Briefly, the general control of contagious animal diseases at the close of 1919 presents an encouraging outlook. The importance of sanitation on farms where live stock is kept can not be too strongly emphasized, since without suitable places for the infection to harbor, practically all the diseases are eradicated more rapidly, with greater ease, and at less expense.

# COMMUNITY TILE DRAINAGE CONSTRUCTION



By JOHN R. HASWELL,  
*Senior Drainage Engineer, Bureau of Public Roads.*

A FEW YEARS AGO almost every farm neighborhood had one or two immigrants who had learned ditching "in the old country." Seemingly without effort they cut uniform slices of soil with the customary long, narrow-bladed tiling spades, and with the regularity of clockwork laid the excavated material in rows on the ditch banks. Experienced ditchers, however, are fast becoming rare, and the shortage in most sections of even unskilled labor has put a serious check on trenching by hand.

The lack of experienced men willing to do drainage excavation has resulted in the development of tile-trenching machines operated by steam or gasoline engines for digging the trench to the required depth at one passage. Trenching machines of this type are expensive and represent an investment in equipment larger than the individual farmer usually can afford to make when the amount of work that he will have for the machine is considered. The machines will complete the drainage work on the average farm in a comparatively short time and with a minimum of expenditure of labor. When cultivated fields are to be drained, rapidity of construction is of considerable importance, as frequently work can be done for only a short period during the spring

and fall when crops are not growing on the land. It is usually advisable to utilize the services of a contractor who owns a machine of suitable type, if available. In most communities, however, such a contractor is not available. If the work is to be done it becomes necessary to secure a suitable trenching machine. The most economical method of doing this is for a number of farmers to unite and purchase the machine jointly. This can be done with the cooperation of the local farm bureau or county agent, or independently. Experience with organizations for other purposes has shown that where a cooperative organization of this character is undertaken it is essential to the success of the enterprise that control be placed in a small board of directors, preferably not more than three or five.

In the spring of 1919 the farmers in the community of Hall, Ontario County, N. Y., held a meeting to decide on some way to get their farm drains constructed. It was decided that "the only satisfactory way to get their ditching done was to form a small company and purchase a tile-trenching machine to be operated in that vicinity," and the ditcher committee that was appointed entered into a contract to buy a power trenching machine. It is an interesting coincidence that this pioneer move in community ownership of trenching machinery took place near the point where, in 1835, John Johnston laid the first drain tile in the United States. A number of Mr. Johnston's methods are still followed in the locality, such as the use of small tile (2 to 3 inch) for laterals and close spacing of laterals.

The community machine was adopted because no other satisfactory method of construction could be had. No hand labor was available, no local contractors with machines, and the State-owned machine had the whole county to cover and could not work on an individual farm longer than six working days of 10 hours each in any one year. The sole idea of the State-owned machines is held to be "demonstration," while these people were satisfied with what demonstrations they had seen and wanted some completely constructed tile drainage systems on their farms.

The farmers most interested in the acquisition of the machine formed the Seneca Power Ditching Co., with five mem-



Two Methods of Ditching and Land Benefited by Drainage.  
A. Cherry orchard on Johnston farm. The land was tile-drained between 1835 and 1850. B. Community trenching machine at Hall, N. Y. C. Cutting trench with ditching spade.

154887°—YBK 1919—6

bers, each having an equal share in the machine. Each member had wet land he wished to drain.

Besides the duties usually appertaining to the respective offices the work was divided among the officers and members of the company as follows: President, in charge of labor on the machine; secretary, in charge of repairs; treasurer, assists secretary; schedule man, schedules the farms and measures work; viewer, inspects new projects and supplies general information to new clients.

It must be understood that these men are farmers and do this work in connection with the trenching machine during

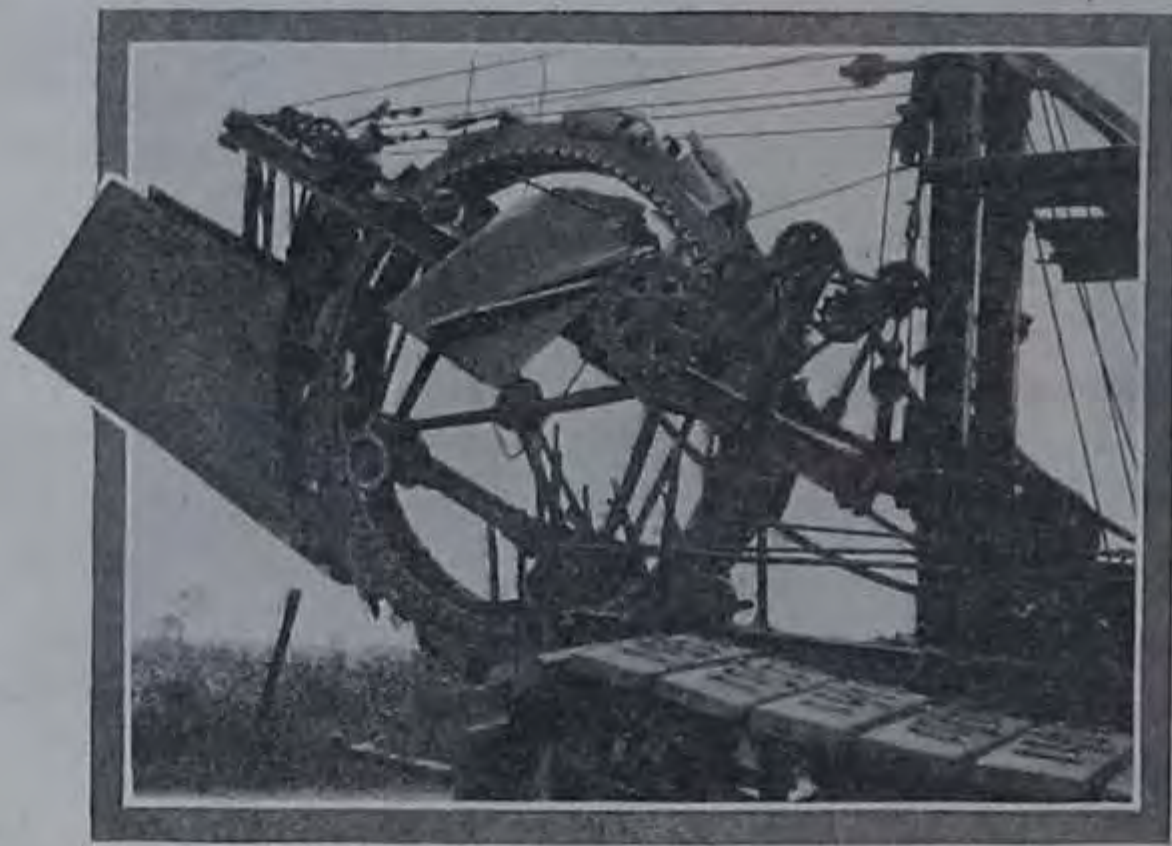

Trenching Machine.

Near view of digging wheel showing earth chute, trenching shield, and chain idlers.

time which must be taken from their farm duties. A skilled machine operator with some initiative is therefore of great assistance in conserving the owner's time. There is usually enough work around the machine to keep a helper busy.

The machine is shown on page 81. It will dig a trench 15 inches wide and  $5\frac{1}{2}$  feet deep, and is operated by a 25-horsepower gasoline motor of four cylinders. When the picture was taken earth was being discharged on both sides of the trench by the use of a chute, in the shape of an inverted V, placed inside the cutting wheel, under the point of discharge from the buckets. A near view of one side of this device is given, showing the digging wheel raised



(p. 82). The farmers much prefer to have the excavated earth delivered at both sides of the trench, since it makes back filling easier. See also page 84, where both sides of the chute are shown.

This company uses a very interesting time saver, in the form of a fuel wagon which is towed by the machine when on the road. As soon as a new job is reached the wagon is detached and parked beside the road. A local agent of an oil company has a contract to keep the gasoline drums filled and supplies the ditcher, no matter where it moves. Since the radius of operation decided upon was only 3 miles, with the village of Hall as the center, the tank-wagon driver has little difficulty in keeping track of the trenching machine. This is a great convenience to the owners, since the operator signs for the amount of gasoline at each delivery, and the monthly bill is rendered to the ditching company.

This company does not undertake any part of the tile laying. The charges for work are 20 per cent higher than for similar work by the State machine (see p. 86), but as the limit for work per individual in any one year is 1,000 rods, and the systems are small, a farmer can complete his drainage at the first attempt, if he so desires.

Another effort on the part of landowners to get drains installed resulted in the formation of the Warren County Ditching Co., which was incorporated in 1916 under the laws of Pennsylvania. The charter of the company contains 20 names. This company bought the smallest type of power machine on the market, made to cut a trench 11½ inches wide. Most of the soil in this section is extremely stony (p. 84), and some doubt exists as to the advisability of attempting to use this type of machine under such conditions. The power was furnished by a single-cylinder gasoline engine of 14 horsepower. From the outset the operation of the machine seems to have been beset by mishaps. Trouble was experienced in keeping a good operator with the machine. A larger machine would at least have had more power and the additional size would have permitted it to withstand greater shocks. Numerous breakdowns occurred, with consequent delays while waiting for delivery of repair parts. The view shows the machine in a field where it had been all summer. The use of the field was lost for

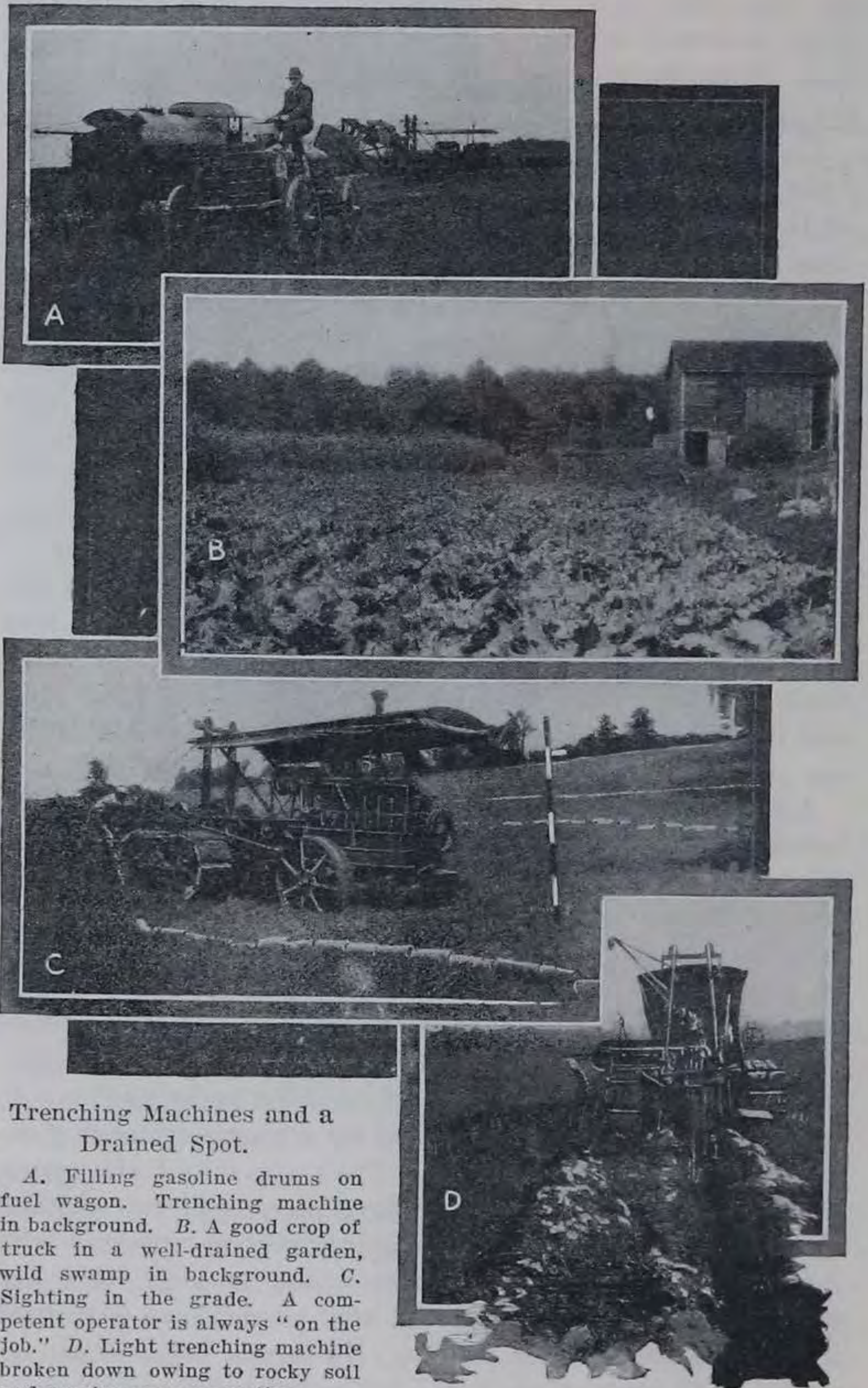

**Trenching Machines and a  
Drained Spot.**

A. Filling gasoline drums on fuel wagon. Trenching machine in background. B. A good crop of truck in a well-drained garden, wild swamp in background. C. Sighting in the grade. A competent operator is always "on the job." D. Light trenching machine broken down owing to rocky soil and previous poor operation.

that season because it was not desired to ruin the crop with a number of trenches cut across the field. The rocky nature of the soil is shown to the left of the trench in the picture. The machine has stood in this position so long that weeds have grown and obstructed the view of the spoil bank and trench. With a competent operator this machine would undoubtedly have given satisfaction if used in a soil free from rocks.

#### STATE-OWNED MACHINES.

The boldest step in farm drainage construction that has been taken in a number of years was the purchase of three traction trenching machines by the New York Food Supply Commission in 1917. This was done as a war measure. The next year the work was taken over by the New York State Food Commission, and 10 additional machines were purchased. To these were added 2 machines connected with the New York State College of Agriculture. The State commissions spent about \$50,000 on machines. The 10 machines supplied in 1918 were delivered at intervals, the last one having been put to work about the 1st of September. During 1918 the machines worked on 150 farms and, it is reported, cut about 40,000 rods of trench, which is estimated to be sufficient to benefit approximately 12,529 acres.

These machines were placed with the county farm bureaus, which executed contracts for the season in which they agreed to cut 5,000 rods of tile ditch, and also to pay the State a rental of 10 cents per rod for every lineal rod of trench cut. No county was to have more than one machine. The machine was to be put in good repair at the end of the season at the expense of the farm bureau using it. A standard price for trenching by State machines is fixed at the beginning of each season.

The farmers had to contract in writing with their farm bureaus for the trenches they wished cut. It was agreed that the finished work should be left as near to grade as the operator could manipulate the machine, the farmer agreeing to remove fast stones, true up the bottom of the ditch to grade where necessary, and lay the tile. The farmer was also expected to haul repair parts, gasoline, and other supplies needed for the machine. In some instances the machine operator and his assistant were boarded by the farmer.

The peace-time operation of these machines is under the direction of the Department of Farms and Markets of New York State.

The scale of prices in force during the year 1919 is based on the lineal rod of ditch, 15 inches wide, and varies with the depth as follows:

*Prices for digging ditches with State-owned machines in New York, 1919.*

Depth.	Per rod.
2 feet 6 inches or less-----	\$0. 55
2 feet 6 inches to 3 feet-----	. 65
3 feet to 3 feet 6 inches-----	. 80
3 feet 6 inches to 4 feet-----	1. 00
4 feet to 4 feet 6 inches-----	1. 25
4 feet 6 inches to 5 feet-----	1. 50

Since these prices are based on actual cost plus a rental of 10 cents per rod for all depths a fair idea of the average costs can be had by deducting the rental from the above figures. Considerable quantities of stone were encountered by most of the machines, which caused a number of breaks and made a high repair bill. There would probably be no saving over hand labor were it available.

Now that the work is settling down to a peace-time basis it is the desire of the State officials of New York to sell the machines either to the county farm bureaus or to local custom operators who would operate the machines as private enterprises. The contracts for 1919 contain a paragraph permitting the purchase, between December 1 and 16, 1919, by the farm bureaus, at the price paid by the State. The money which the counties have paid as rental will be applied as part of the purchase price.

#### CONSTRUCTION BY MACHINERY.

The machine-cut trenches vary from 11½ to 15 inches wide, and some of the machines can cut as deep as 5½ feet. They are equipped with a grading device which allows the machine to cut a completely graded trench at the first cut, provided there are no stones or roots which obstruct the passage of the machine. In soft, wet, mucky loam a rock as large as a man's head can often be easily removed, while in a hard, dry clay a stone as large as one's fist may necessitate raising the cutting wheel and finishing the ditch to grade by hand. Large green roots should be cut with an ax, and stumps on

the ditch line should be split by an explosive or burned out. No machine which does not have a satisfactory grading device should be considered.

Only the average day's cutting should be taken into account in estimating the performance of a ditching machine, with proper allowance for time lost in changing from one trench to another and in delays caused by breakdowns. The consideration of a number of tile installations in connection with the work of the Bureau of Public Roads brings out the following facts: The farm with the minimum average day's trenching had soil with loose rock in the bottom of the trenches, which were 3 feet in average depth; only 439 feet was the average day's run, not quite 27 rods. The average under ordinary conditions of breakage, ground, etc, is about 800 feet, or less than 50 rods. The greatest average yet obtained was 1,540 feet, or 93 rods per day for the entire job, including time lost for repairs and rain. The soil was a heavy silt loam containing no rocks and few stumps. The average of the 15 New York State machines over one year was but four operating hours per day, owing to numerous moves from one farm to another, breakdowns, and rain.

Costs of construction can be itemized from the figures given for the New York State machines, adding the local cost of the tile. Roughly speaking, a system consisting principally of 4-inch tile will to-day cost 8 cents per foot installed, which in round numbers would probably equal \$75 per acre. This is with a spacing of laterals of about 50 to 60 feet. This is expensive work, but when properly done the results pay a big dividend. It will also be noted that in this class of work the machine effects no saving of money, but it does make the execution of the work possible where hand labor is not available.

Several types of horse-drawn trenching machines have been put upon the market, which, in some instances, have met with approval when the local conditions were favorable. No machine of this type yet developed will cut a complete, graded trench at one passage; only a layer from one-half inch to 4 inches thick is removed at a time. This makes it necessary to open up a considerable length of trench at one time, which is always objectionable, for, if rains occur, the trench is apt to cave and be partially filled up. On soft ground repeated passage of horses and machines breaks

down the banks of the trench and causes much difficulty in cutting it to the proper depth. A number of horses are required to operate most of the plows and machines; hand work is sometimes required to throw out the loose material; and in all cases some hand work is necessary to secure a true grade. Most of these plows cost more than the average farmer cares to invest in a special implement for which he will have only a limited use.

#### INDIVIDUAL EFFORTS.

Power machine trenching for farm tile drains has been practiced for some years with success, but has been confined to neighborhoods where a contractor owned a machine, or to farmers with enough capital to buy a machine. Some farmers buy secondhand machines, put them in running order, and sell them again, after constructing their drainage systems. One machine is known to have belonged to four different owners in five years, and was still able to dig a trench when last reported. Each owner had paid about \$500 for the machine, to which was added \$100 additional for the cost of getting the machine from one farm to the other, and for repair parts necessary to place the machine in condition to operate. The machine would thus cost about \$100 for the period of work, exclusive of the interest on the investment, provided, of course, the cost price was realized in the sale. This happened in every instance reported. At present the increase in freight rates, and in the cost of spare parts, would change these figures materially.

These individual efforts are praiseworthy, since in every case the drainage has been installed, but it is not always the most economical procedure, as time is lost by new operators learning to manipulate the machine, and poor work results until they become skilled. Frequently new operators cause serious damage to the machine, because they do not know what to expect from it, and fail to act quickly and correctly in an emergency. Long delays result when repair parts have to be ordered from the factory. An operator who knows that his interest in the machine will end with the work he is then engaged in constructing will usually let the machine get into a run-down condition. On the next job it will require many days of close watching while running, until the new operator is able to operate the machine properly.

The solution of the matter is to have the operator go with the machine. This is impossible, in most cases, with a farmer owning his own machine and selling it at the end of the job. On the other hand, it is exactly what a contractor does. The permanent operator learns all the short cuts on getting the machine into position with the least loss of time, learns how to operate the machine at the highest speed, discovers by experience the best way to handle stones encountered in the trench, and is soon able to distinguish the discordant sound of something gone wrong from the steady hum of well-oiled mechanism.

In the instance cited above, the four farmers could have obtained better results if each had paid his share of the machine's cost, employed the same operator the entire time, and then jointly sold the machine. Trouble is encountered when the operating costs are assessed to the different shareholders. This has prevented very much cooperation in some sections and the difficulty of finding in one locality enough interested persons with capital to form a small company has held others from purchasing a machine to do the work.

Many of the States at present do not offer numerous opportunities for contractors for this class of work. The work would be scattered and of small amounts. Frequent moves would be required to get from one farm to another as the convenience of the landowner demanded. The contractor is not often in a position to say to the farmer, "You do the work now if you want to get it done." For these reasons and probably some local ones, contractors in general are not active in searching for small trench work. Occasionally a farmer with a machine will take up outside work after he has drained his own farm, or a pipe-line contractor will take up farm-drainage work as an adjunct. These instances are rare. Most of the contractor type of machines cut a larger trench than that desired. It therefore appears that the best way for the farmers to get their drains installed, when they are situated beyond reach of a contractor and have not enough land to make a \$3,000 to \$4,000 machine worth while, is to get a community machine by cooperative purchase. This is not to get a cheaper job, but to take advantage of the small amount of labor required with the machine as against doing the work entirely by hand.

## COMMUNITY OPERATION.

Methods of conducting the business incident to the machine operation must necessarily differ with local conditions. Some general suggestions will apply in most cases.

It is hardly too much to say that the success of the enterprise in starting a trenching machine in a neighborhood is dependent on the quality of the operator who is retained to run the machine. He represents the owners on the job, is the go-between between them and the farmer, and should be a man of tact and foresight. Besides all these he must be qualified as a mechanic.

The operator should know his machine. A man that has attended a tractor school is valuable, provided he has had sound, basic instruction in gas-engine practice. He has to be observing and alert. A man who can stop the machine instantly when a chain flies off or the machine strikes a stone may save a week's salary by preventing the loss in breakage and the delay in installing a new part. A skilled operator can set grade targets on simple work with a carpenter's level, if the fall is great enough. In these instances the services of an engineer are not necessary.

Where there is considerable flat land to be drained, or the system is large—that is, contains single lines more than a quarter of a mile in length—an engineer should be employed, if available. Some county agents now have small drainage levels and can give satisfactory grades. The competent operator will measure down from the survey stakes and check the depths of cut.

Among the greatest benefits derived from having a complete survey made before any trenching is done is to have the main tile large enough to carry all the water that will be eventually discharged into it, and also to have it deep enough to enable laterals to be taken off to the lowest tributary land. A map should be supplied and be kept for future reference.

A survey will also determine the different quantities of tile of various sizes required. The tile should be on the farm, distributed to one side of the proposed lines if possible, before the machine comes upon the place. The tile should be laid in the trench close up to the machine, and the laying should proceed as fast as the machine cuts the trench. It



is recommended that the machine always cut up hill. Some tile layers ride on the projecting shoe of the machine in the bottom of the trench, while others use a tile hook for the smaller sizes most used and stand on the bank of the trench while using the hook. The tile layer is thus intimately associated with the working of the machine, and it seems to be a good policy to have him part of the construction crew. He is required to true up the bottom of the trench at the start before the machine has cut down to depth or where the cutters have been raised to pass over a stone. When the machine stops for minor repairs or to renew the supply of gasoline or water, the tile layer can usually be profitably employed in cleaning the cutters, replacing dull ones with sharpened cutters, or filling grease cups. Thus it appears that the tile layer can be advantageously used as one of the regular crew of the machine. This will keep the work around the machine well organized, and the tile installation will keep pace with the trench cutting. In soils subject to caving this is of prime importance. Damage seldom results from a trench caving in after the tile is in place, but it is a tedious procedure to remove wet earth from a trench if the sides have slipped into it before the tile is laid.

A helper is usually included in the machine crew. A large boy or young man can be used to advantage, or he can be an understudy for the operator. The progress of the work will depend in no small degree on the helper. He assists the operator in making repairs, refilling with gasoline or water, filling grease cups, and, if competent, can be of great assistance in setting grade targets.

The helper also passes tile to the tile layer, if the latter rides in the trench on the shoe of the machine. With the smaller sizes of tile a tile hook can be used to advantage and the helper's assistance will not be needed to pass the tile. He can then follow behind the layer and patch up any large cracks at the joints and blind the tile. Blinding is bedding the tile in the trench with loose earth from the sides, making certain that enough material is placed to cover the tile several inches deep. A good helper is like the quarterback on a football team. He is in the middle of most of the plays and yet covers the greater part of the field.

Thus the three men constitute the team to get the work done. The operator should be the foreman and have general charge. Besides operating the machine he should have an eye to the tile laying. The tile layer has a steady, plodding job, only interrupted by occasional stones in the trench, breaks in the machine, or when changing from one line to another. The helper, as his name implies, should be quick to help in any position where he can be of assistance. As these men get accustomed to working together they will take the little short cuts automatically, few orders will need to be given, and the maximum of work will be done with the minimum expenditure of energy.

The above is the ideal crew from the standpoint of getting work done, but the objection will frequently be raised by the farmer that he wants to lay his own tile and has a man available to do it. Also, the man in charge of the labor for the machine will hold that he has enough trouble with the operator and helper without having a third man to bother with.

#### VALUE OF TILE DRAINAGE.

The value of tile underdrainage on naturally wet farm lands has long been appreciated. In localities of cheap land the wet areas are left out of the scheme of cultivation, but as the region develops and values rise interest in drainage becomes stronger. Owing to the rise in land values the time comes when naturally well-drained farm land costs more than the cost of wet land plus the cost of the drainage and improvements. Under these circumstances the drainage of large tracts is profitable. Another phase of the subject is presented by the relatively small areas of low, wet land on individual farms. Here the cost of drainage works is usually compensated by the increased crop during the first few years after the drains are installed. The increased value of the farm, due to the removal of some unsightly wet spots, is often more than the outlay for the drainage construction. (See illustration of corn on peat land, p. 93.)

All of the agencies interested in improving farm production have persistently preached the need of drainage on wet farm land. Demonstrations have been made of the proper

way to install tile, and numerous publications have printed the results obtained from actual drains installed. But the question of how to get the work done, where to get the



**How Drainage Helps.**

A. Corn on peat bog that has been tile-drained and subdued. B. Crop of weeds on peat poorly drained by open ditch.

labor, has in most cases been "sidestepped." At present the community-owned machine offers the best solution of the problem.

# HOW TO USE MARKET STATIONS

By G. B. FISKE,  
*Investigator in Marketing  
Fruits and Vegetables, Bu-  
reau of Markets.*

“WE THINK we know how to raise crops well enough,” asserted a confident farmer. “Anyhow, we are not sure that somebody from outside can tell

us just how to run our farms; but when it comes to selling our stuff we must admit that other people are closer to the market than we are and ought to be able to tell us something.”

This is the first purpose of the market station—to supply information from trained men located at market centers where the produce is handled and sales are made. Accurate, prompt, impartial market news collected early in the morning is wired from city to city, is published during the day of collection, and reaches city dealers the same day and remote country shippers the next morning. This service appeals to dealers as well as to the shippers who are farmers and fruit growers, for neither class may act confidently without having before them the facts concerning actual sales each day and all the important items affecting the markets.

## WIDE SCOPE AND CIRCULATION OF MARKET INFORMATION.

Such information is available through the Department of Agriculture concerning the marketing of 500,000 to 750,000 cars annually of fruits and vegetables worth three quarters of a billion dollars. The circulation of this market news is



Dealer's Display of Produce.

wide. It has been estimated four to five million general readers are reached through newspapers. Market bulletins, reports, reviews, and special articles on fruits and vegetables alone go directly to 125,000 growers and dealers. Telephone and telegraph reports on these products were sent out on request to about 19,000 people in 1918. They went to men who were glad to pay the toll charges. A Kansas fruit growers' association paid \$12 a day merely for telegraphic reports of carlot shipments.

#### CLOSE TO SELLING END.

Market stations are well termed "branches." Like the parts of a tree, they reach out in every direction from the central office. Connected by wire and mailservice, there is constant circulation of vital news, out and return. The raw materials are gathered and worked over to make the reports, reviews, and press articles which are shed, like leaves and fruit, for the benefit of the public. The market station man is the caretaker, and he works from the early stir of activity in the market section until the day's stint is finished. Usually he is a man with considerable technical training, selected for the work because of experience in production or marketing.

The market station man's work, like that of the county agent, is localized, although it is at the selling end and not at the producing end of the agricultural deal. His field begins where that of the county agent leaves off, and he is in a position to analyze market problems comprehensively because he meets dealers, shippers, and producers and is in daily touch with local trade conditions.

#### WHAT IS A MARKET STATION?

But, dropping comparisons, what is a market station? It is a branch of the Bureau of Markets of the United States

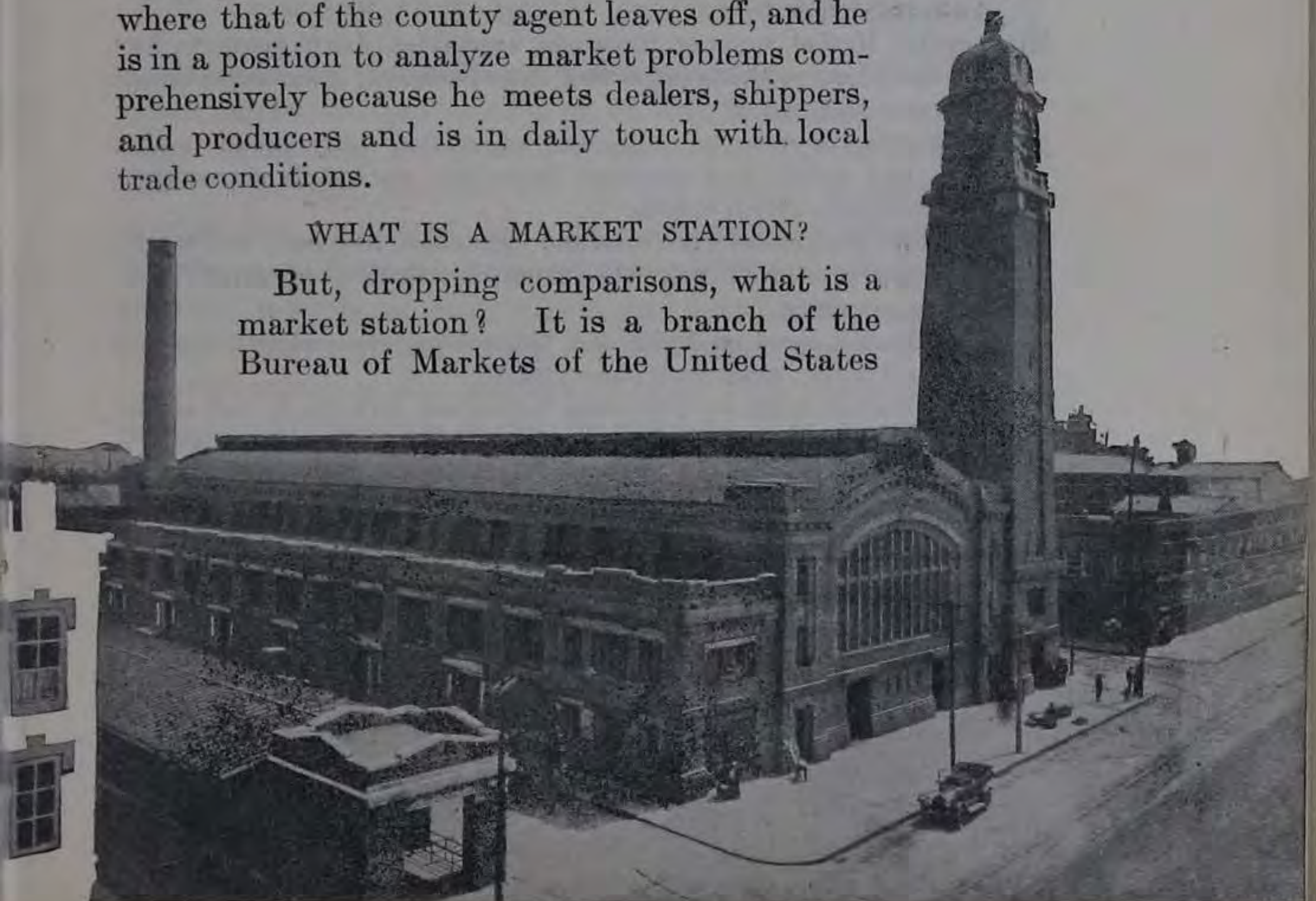

Department of Agriculture established in a large city primarily for the purpose of collecting and distributing market news. Each branch office, connected by leased wire with Washington, receives and distributes daily the news from each station. Beginning in 1915 with four commodities reported from only a few of the larger cities, the number of branches was increased steadily, reaching 34 during the war but now reduced. The scope of a number of the leading branches has been enlarged.

In the various branch offices the following lines of work are represented:

- Baltimore: Market news service on fruits and vegetables; food products inspection; grain supervision.
- Boston: Market news on fruits and vegetables, dairy products, live stock, and meats; food products inspection, stockyards supervision; grain supervision.
- Chicago: Market news on fruits and vegetables, dairy products, live stock and meats; food products inspection; seed reporting service; hay and feed market; stockyards supervision; grain supervision.
- Cincinnati: Market news on fruits and vegetables; food products inspection; grain supervision.
- Cleveland: Market news on fruits and vegetables; food products inspection.
- Denver, Detroit, Indianapolis, Los Angeles, Omaha, Pittsburgh: Market news on fruits and vegetables; food products inspection; grain, stockyards supervision.
- Kansas City: Market news on fruits and vegetables; seed, hay, feed marketing investigations; live stock and meats; food products inspection; stockyards supervision.
- Minneapolis: Market news on fruits and vegetables, dairy products, hay and feed; food products inspection; transportation; grain supervision; grain standardization.
- New York: Market news on fruits and vegetables, dairy products, live stock, and meats; food products inspection; stockyards supervision; transportation; grain; cotton.
- Philadelphia: Market news on fruits and vegetables, live stock and meats; dairy products; food products inspection; stockyards supervision, grain supervision.
- Portland: Market news on fruits and vegetables; grain supervision and standardization; stockyards supervision.
- St. Louis: Market news on fruits and vegetables, live stock, and meats; food products inspection; stockyards supervision; grain supervision.
- San Francisco: Market news on fruits and vegetables, dairy products; transportation; seed reporting.
- Spokane: Market news on fruits and vegetables, hay, and feed; grain supervision.

These stations supply market news on fruits and vegetables, live stock and meats, dairy products, grain, hay, and mill feeds, and seeds. This service tends to displace many private reports quoting news which is likely to be of a less comprehensive, prompt, and reliable nature. The fertilizer sections have conducted inquiries and made reports on the supply and public demand for fertilizers and fertilizer material. The transportation sections have been of great value in securing regular and complete reports of shipments, obtaining the prompt unloading and return of cars, and securing cars and transportation facilities for shippers. The food products inspection work provides an official inspector at important central markets to investigate and certify the condition of shipments upon arrival. The importance of this inspection is plain as supplying a basis for settlement of differences between country shippers and city receivers of carlot produce. Consignments of less than carlots may be inspected also at little cost to shippers.

Each permanent market station secures from local freight agents in each of the more important markets the number of cars arrived of each crop being reported and, if possible, the number of broken and unbroken cars on track. Reports of home-grown stock are also obtained when on the market in large quantities.

#### COOPERATIVE HELP AND INFORMATION.

Through cooperation with headquarters at Washington, much important material is given out from the market stations concerning the general work of the Bureau of Markets and information more or less directly related to market conditions but collected by other bureaus or departments. Among such important items are reports of stocks in cold storage, reports of crop yields and conditions, export and import statistics, and special regulations affecting marketing.

Cooperation of the market stations with State marketing agents in 27 States is decidedly helpful. The National service is concerned chiefly with the wholesale marketing of produce shipped from one State to another, but the State agents are interested in local produce, both wholesale and retail. The National and State forces are often united not only in securing information, but in helping to solve special

marketing problems and conditions, such as the more rapid movement of crops in seasons of heavy production.

#### MARKET TERMS AND ABBREVIATIONS.

Most of the abbreviations in the market reports are in common use elsewhere and are readily understood. A few, however, may require brief explanation:

"A2½" and "B2½" refer to standard apple grades established by law in various States. The figures describe in inches the least diameter of the fruit in that grade. "4's" or "6's" are carriers holding four or six baskets. In cantaloupe reports "45's" are crates containing 45 cantaloupes. The term "carlots outweigh" refers to carlot sales at unloading points made on the basis of the weight of contents at the time the car is unloaded.

#### ABOUT THE MARKET QUOTATIONS.

The market quotations reported in the daily bulletins are obtained daily. This information is wired to Washington, where telegraphic summaries are prepared and sent to each office from which bulletins are issued.

Many of the terms referring to quality, condition, etc., are necessarily general, because it is impossible to report the specific condition of each separate car or consignment. The quality and condition of a crop which is being reported from a given district may cover several cars.

Price quotations, unless otherwise stated, apply to the price at which the bulk of the merchantable stock of any given commodity is being sold. Prices for an extra fancy grade may be higher than the quotations reported. Likewise a poor or inferior product may sell for less than the quotations given in the bulletins.

By "jobbing price" or "sales to jobbers" is meant the price at which jobbing lots of any commodity are sold when the car is broken, or the price at which the jobber buys. By "jobbing lots" is meant large quantities in which the fruit is sold by the carlot receiver to the jobber, such as 25, 50, or 100 bushels, barrels, crates, dozens, baskets, or other unit of container or measure by which fruit or produce is sold. Strawberries, peaches, cantaloupes, or other quickly perishable commodities are usually "jobbed" in smaller quantities than



the less perishable products, such as potatoes, cabbage, and onions. The "jobbing price" does not mean the original carlot price nor the price to retailers in small lots.

Not all products are reported on the jobbing-price basis at all seasons of the year. For example, during the period of heaviest movement of potatoes, most shipments are sold in carload lots intact by the receiver to the jobber; hence, during this period carlot prices are quoted on potatoes. In some markets onions, cabbage, citrus fruits, watermelons, and bulk apples are sold on carlot basis, and in a few markets barreled apples are sold in carlots for storage. In every case, the basis upon which quotations on any particular commodity are made is stated in the bulletin, and all exceptions are indicated.

There may not always be a definitely determined jobbing price in some of the smaller markets, where the functions of the carlot receiver, jobber, commission merchant, and wholesaler are not clearly separated. In such case, the quotations are usually on the basis of sales to large retailers, chain stores, or others who buy in jobbing lots, though they may not conduct a jobbing fruit or produce business. If there is any question at any time concerning the quantity basis on which quotations are made in any market, inquiry may be addressed to the Chief, Bureau of Markets, Washington, D. C., for a more complete explanation of local conditions in a given market.

Prices quoted in market bulletins represent actual sales, not prices asked or quotations given, or predictions as to probable future prices. Hence, it may be that on a rising market the prices quoted may seem low when the bulletin is received, and, vice versa, on a declining market the prices given may be high by the time the bulletin is received.

Quotations usually represent the condition of the respective markets up to approximately 9 a. m., local time, but bulletins are not issued until about noon. Consequently, it is impossible to include fluctuations which may occur between these hours in the market bulletins.

In many important markets it would be impossible to get carlot price quotations, because very few or no cars are sold intact by the original carlot receiver in that market to the local jobber, hence there would be no basis of actual sales upon which to report a carlot price. In most of the important markets there is, however, a fairly well defined

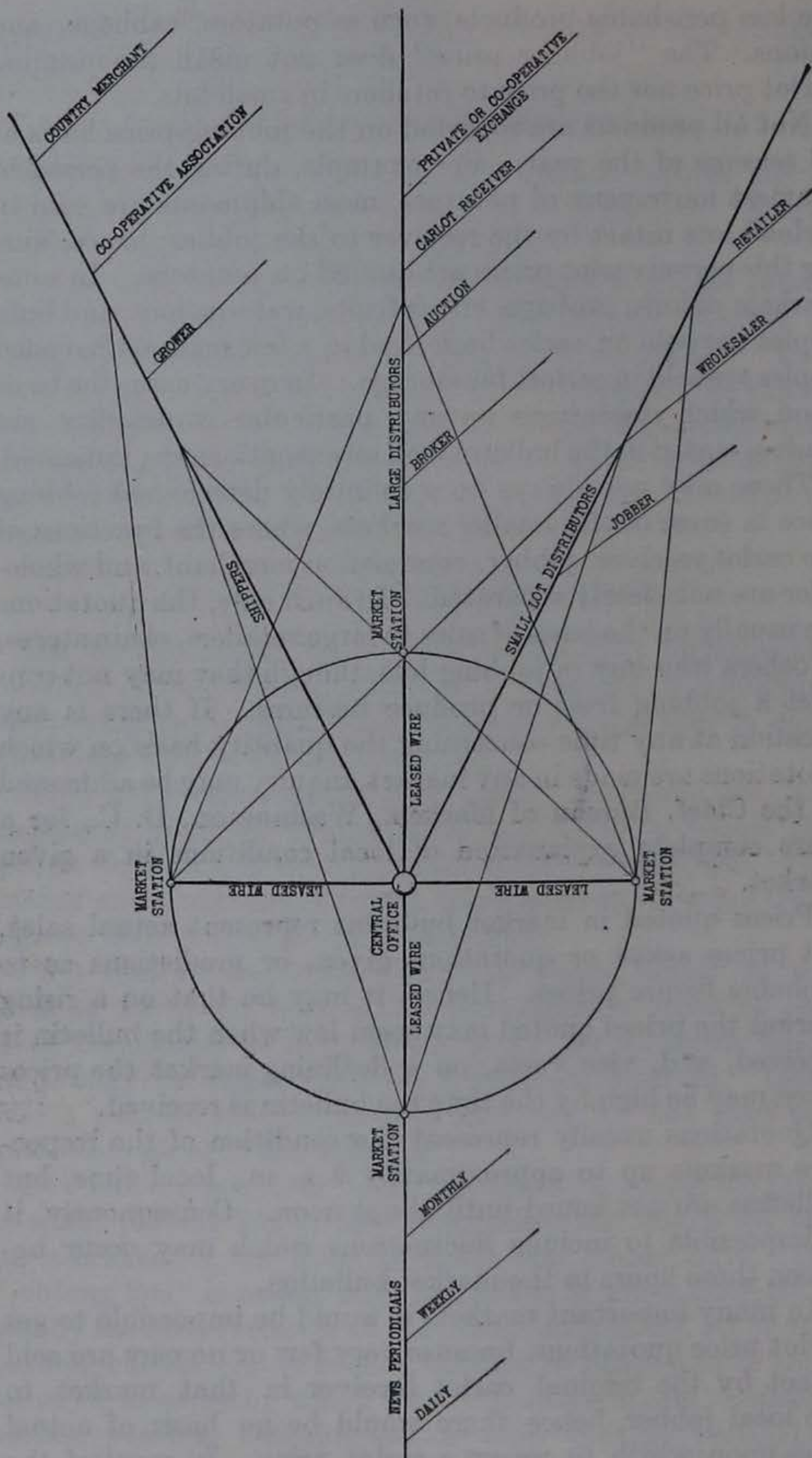

Direct Circulation of Market News.

jobbing trade which buys at the prevailing jobbing price for the day.

Returns to a grower or shipper who may have consigned a shipment to a commission merchant are usually made on the basis of the jobbing price received, from which, of course, freight, commission, and other expenses are subtracted. Hence, shippers of consigned products are usually more interested in the jobbing prices prevailing in a given market than in carlot price quotations.

In certain western and southern markets, however, very few shipments are accepted on consignment. Large dealers prefer to purchase their requirements outright in order to be assured of a steady supply. As a sufficient supply to meet the market demands is usually purchased,

Produce in Freight Terminal, Cleveland.



Transferring a Shipment of Produce at a Railroad Terminal and Ferry, New York.

consignments tend to overload the market and may be sacrificed if shipped without making previous arrangements.



Inside a Produce Warehouse, Baltimore.

Thus, in markets where consignments are not looked upon with favor or where previous connections have not been established, the farmer who ships on consignment can not be sure of receiving the prices quoted in the market bulletins.

The jobbing price more truly represents the actual market conditions. In other words, the jobbing price responds to increased or diminished supply or demand more rapidly than

either carlot or retail prices, hence gives a better indication of the state of the market than would either carlot or retail prices.

In order to estimate what he should expect to receive for his product in a given market and on a given day, the grower or shipper should first consider the grade, pack, quality, and condition of his product compared with the bulk of that product as quoted in the bulletins for that day; second, deduct freight or express charges, other costs, and commissions.

Even after proper deductions have been made, returns may not always agree with prices quoted in the bulletins, because of unexpectedly heavy receipts later in the day, sudden changes in weather, or other factors which influence the market quickly. In some markets, therefore, prices may materially change during the day from those prevailing at the time when market quotations were secured in the early morning.

Anyone desiring to secure information more quickly than is possible through the

Unloading Produce in Freight Yards,  
Pittsburgh.



Loading Potatoes at Boston Terminal,  
Charlestown Freight Yards ("Potato  
Row").

mails may have all or any part of any report sent by telegraph,

charges collect, from the nearest station. A blank for entering the details of the desired telegraphic service will be furnished upon application.

"MARKET AND PRICE" PHRASES.

"Market excited." This represents a condition of uncertainty and a decided bullish tendency on the part of the seller. It suggests a rapid upward tendency and considerable price fluctuation.

“Market stronger.” This represents a condition of increasing confidence on the part of the seller, with the likelihood that the present demand will consume present supplies, and supplies in sight can be absorbed at prevailing or slightly higher prices.

“Market strong.” This represents a condition of firm confidence on the part of the seller. There may be a good demand and supplies may be relatively light, so that the seller is likely to stiffen the price at the first opportunity.

“Market active.” This represents a condition of quick sale, good demand, and a generally healthy condition. There may be no decided change in prices, although it often indicates an upward trend.

“Market firm.” This represents a condition of strong confidence in general conditions, resulting often in the strengthening of a price range, but seldom in actual price advances.

“Market steady.” This represents a normal movement, with steady, consistent trading showing no decided price changes one way or the other.

“Market unsettled.” This represents a condition of uncertainty on the part of sellers and usually indicates a weaker tendency. There may be no actual price changes one way or another. Represents a waiting attitude, with spasmodic trading.

“Market dull.” Represents light trading and suggests a condition of uncertainty and possible depression. There may not be any actual change in prices.

“Market weak.” This may be used in describing a condition of actual price decline, with the possibility of further decline, and represents a decided lack of confidence on the part of the seller. It may also be used when no actual price declines have taken place, but with large supplies on hand and heavy supplies in sight it is the prevailing opinion that a decline is inevitable.

“Market weaker.” This is a comparative term and refers back to conditions of the previous day. It may represent an actual decline in price, although the relation of market price should not be the governing factor. The reporter should conclude by his “sense” of the market that less confidence exists than when the market is steady.

“Market demoralized.” This term is to be used only in very unusual cases and represents a condition when stock can not be moved at any price. It represents a market so completely glutted that even stock of high quality can not be moved.

As used in the official market news reports, “market” represents the views of the seller and “demand” those of the buyer.

#### USING A MARKET REPORT

The veteran reader of market reports, trying to size up the produce situation, is likely to begin by taking up the latest daily schedule of a leading staple, say potatoes. He looks over the report from a leading market, in this case very likely Chicago, and notes that carlots are quoted 15 cents per hundredweight lower than yesterday. He glances at the reports for Minneapolis, Kansas City, New York, Boston, and Philadelphia, and notes that prices in these cities show little decline.

To find the reason of the weakness in Chicago he notes the report with more care and observes records of heavy arrivals of stock from Minnesota, Michigan, and other northern shipping States and concludes possibly that the drop was caused by these large offerings reaching the nearest leading market, in conjunction with the heavy supplies from other producing sections. If condition of the stock is noted as poor or ordinary or with much field frost, he decides that a part of the

Market Centers in Norfolk, Va.

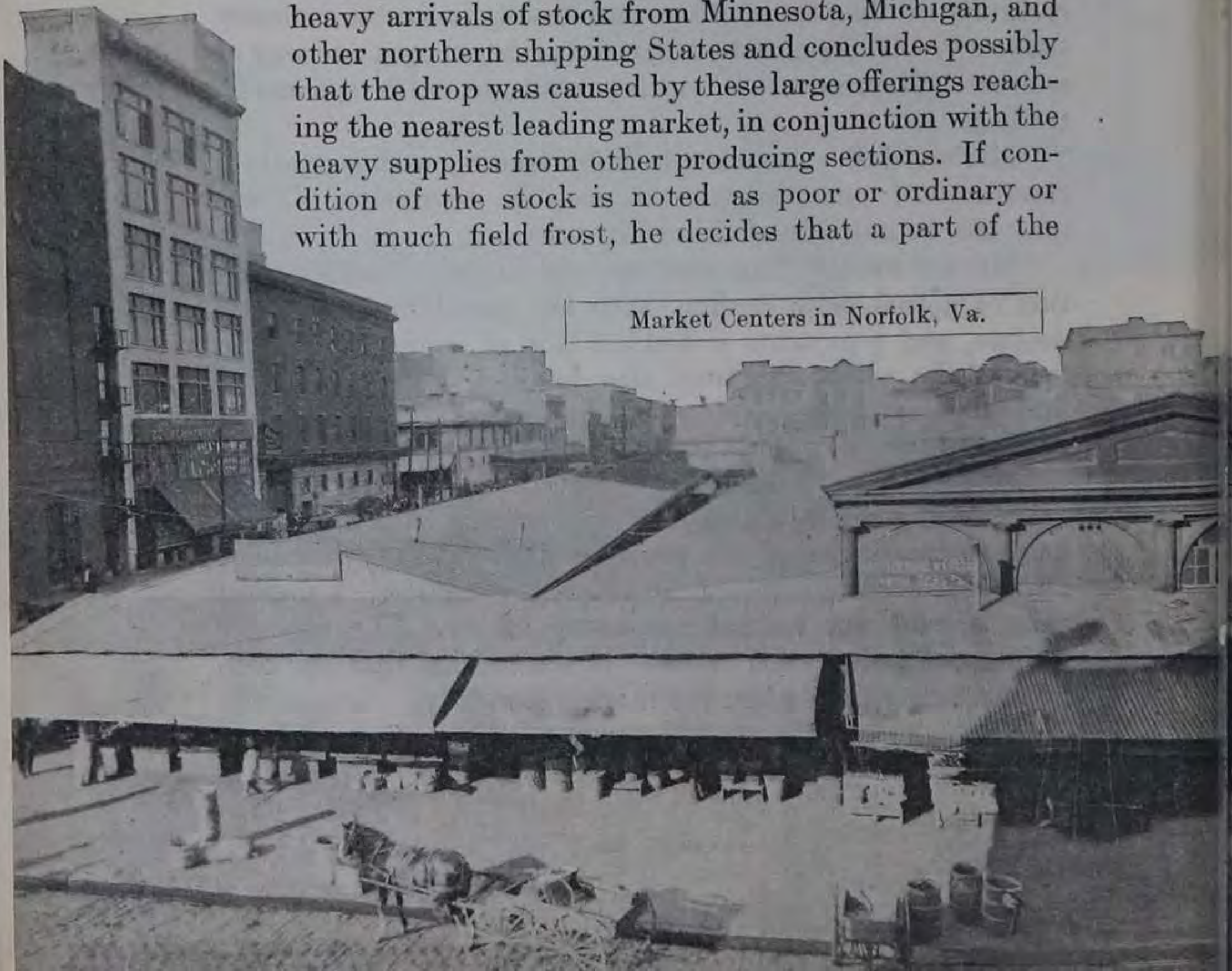

market weakness may be due to that cause. Possibly poor demand and some stock poorly graded may be mentioned as adding to the unfavorable market position. From his file of daily reports for the week, or the Weekly Review issued by the Bureau of Markets, he notes whether the decline has been persistent or whether it seems to be one of a series of short ups and downs or part of a reaction from an advance.

According to the nature of the movement, he decides whether the recent trend has been definite in one way or the other. Concluding perhaps that the decline marks a general downward trend, he glances over the reports from leading producing sections supplying Chicago and finds that the trend of f. o. b. prices is also downward at Waupaca, Wis.; Moorhead, Minn.; Grand Rapids, Mich.; and in the Grand Junction district of Colorado, and that hauling and shipping are active at these points.

Evidently the western crop is now moving fast and the Chicago carlot market has been first to feel the effect in a marked degree. Reports of relatively light arrivals at other midwestern consuming markets may confirm this. He mentally goes over the crop conditions with the aid of the carlot summary, weekly reviews, and special articles if the main facts are not already in mind. He notes the size of the crop and the amount shipped from each State for the season to date. He observes carefully the attitude of growers, buyers, and shippers; whether anxious to trade or holding back. He takes into

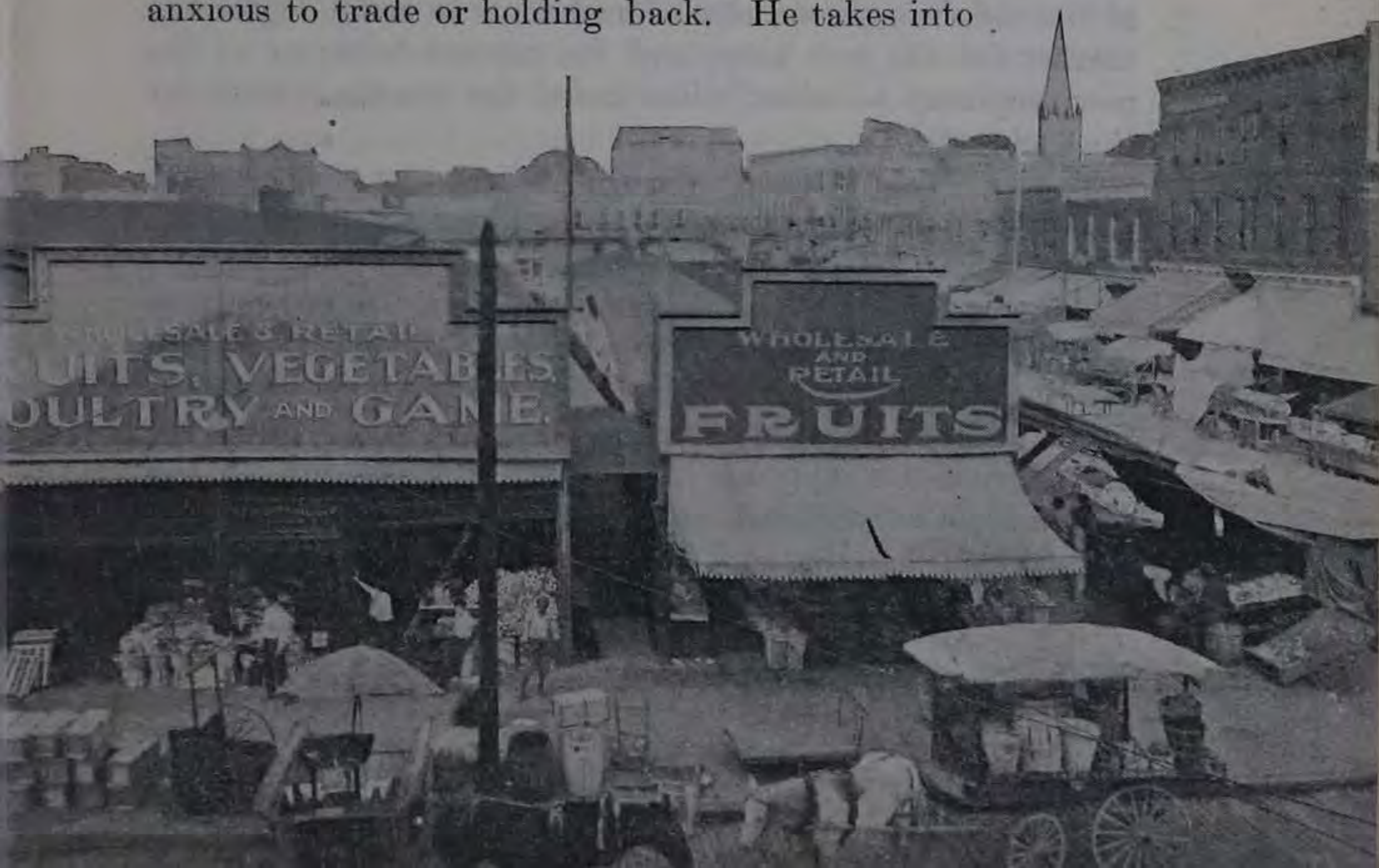

account the car supply, whether abundant or if shortage exists, and the weather conditions, whether especially favorable or otherwise for rapid and safe transportation. He glances over all the reports to note any indications of slackening demand. If it is late in the season he takes note of conditions in eastern shipping sections and consuming markets. He may even note arrivals of Canadian stock and exports and imports if there is reason to suspect important developments on such lines. If the new southern crop is about ready or beginning to compete, he takes that into account—its size, condition, quality, and location. Then, having the situation in mind in all its essential aspects, he forms his own judgment of the probable course of the market.

From daily observation he is able to carry the general points in mind, and often hardly more than a glance at the report of the leading markets is needed. He is able to detect the hinge on which the market is turning and almost to feel its movement. He says, "Chicago carlots are off another 10 cents; the market is going down," basing his conclusion not merely on the decline itself but on its relation to the previous trend and to the other conditions which he has kept in mind almost unconsciously. Another time the "hinge" of the market may be in the East, turning on big reserves of stock in Maine or Canada or the shipments of the new crop from Virginia. The critical market then may be New York, Boston, or Philadelphia. Prices and conditions at the end of the old crop season often foreshadow in some degree the market for the new crop, and the market behavior of the new crop may be some indication of the coming market for the main crop.

To size up the situation for any crop at any time requires the quick balancing of many facts and causes. No general directions can be given to fit every case. The way to learn to use market reports is to use them. Expert use comes from long practice. In time the reader learns to read between the lines and to feel the market from indications that may mean little to the beginner. The expert's quick sizing up of the situation appears like magic or guesswork to the person little experienced in this line.



The behavior of the potato market is in general like that of other staple fruits and vegetables which have a shipping season continuing throughout the winter. There is often a time of low prices during the main harvesting season, followed by recovery lasting perhaps until the end of the calendar year; then comes an irregular course throughout the winter, depending partly on condition of weather and transportation, and finally a new movement in the spring either up or down, according to the supply on hand when the active spring movement begins.

#### SEARCHLIGHTS ON THE APPLE MARKET.

The apple grower, shipper, or dealer, like the potato handler, needs experienced and intimate knowledge of the situation. A study of such markets as Chicago, Denver, Kansas City, St. Louis, and the eastern auctions may afford an indication of the boxed-apple situation. The eastern barreled-apple market centers in such cities as New York, Boston, Philadelphia, Detroit, and Pittsburgh, but in seasons of shortage of the western crop the middle-western markets have an important relation to the outcome of the barreled-apple marketing season. The whole commercial apple situation must be in mind. Where is the crop this season and how located in the box and barrel sections? Which varieties are yielding most this season and what is the market quality? What is the probable export situation and the eastern competition from Canada or elsewhere? Will the sugar shortage or high prices interfere seriously? How has the market started, as indicated by sales of early kinds and advance contracts for late varieties? What is the apparent attitude of commercial buyers? Are they disposed to contract freely and is cold-storage space in demand? Are the box and barrel supply and the labor situation likely to affect the handling of the crop? What is the general business situation as related to the consuming demand? What is to be said regarding the outlet for dry and evaporated stuff and for fruit-juice products?

#### PLENTY OF BACKGROUND NEEDED.

All such points must be kept constantly in mind in order to grasp the full meaning of the day-to-day and week-to-week changes shown in market reports and reviews. Each

crop is a market situation by itself, although at times a number of leading lines of produce appear to move in the same direction under the influence of general causes, but in general each crop demands a good background including all the facts that may indicate or explain the market changes.

#### A COMMON COURSE OF THE MARKET.

The ordinary or natural market course of a line of perishable produce is somewhat as follows: It starts high with active movement even for inferior stock, because the demand has the sharp edge of novelty and appetite. The price gradually declines and poor stock becomes harder to sell as the supply increases. Lowest prices arrive soon after the heaviest shipments commence and a glut may occur, especially if many sections are shipping at once and there is much poor stock. Then, with a decreasing supply, prices advance, sometimes recovering much of the early decline, but usually not reaching the opening prices because demand is far less keen at the end of a long season. If the last of the shipments are inferior, as happens frequently with many perishable crops, the season may close at or near bottom prices.

The common or natural market developments do not always take place as might be expected. Quite frequently superior quality of the main crop or absence of general competition will bring higher prices in mid-season. Unexpected shortage may cause the reserve stock in storage to sell at very high prices at the close of the season, especially the less perishable crops like potatoes, onions, apples, cabbage, etc. Careful study of crop, storage, supply, and shipment should enable a fairly good judgment to be made of the outcome.

On the other hand, it is very difficult to form any reliable market judgment for the quickly perishable, short-season crops like strawberries, peaches, and melons. Markets in such lines are irregular, differing widely at the same time in different cities because the nature of the crop does not admit of safe transfer between distant points or long keeping in cold storage. These lines feel quickly and severely the effect of oversupply, whether of carlots or from neighboring sources. As these crops are not strictly necessities, the demand is somewhat uncertain, depending largely upon the buying power of the public, which may vary greatly from season to season.

## THE EBB AND FLOW OF VALUES.

The course of the market often appears like that of the tide, advancing or receding gradually all along the line, moving at a different rate in some places than at others and the general direction almost concealed by the ups and downs of the separate waves, but in general moving irresistibly in the appointed direction until the turn comes. Then occurs the backward movement, as mixed and puzzling as the first, but still quite definite in direction and limited in extent.

Of the main price movements, it may be said in general that they usually go farther in either direction than the conditions seem to warrant. This is owing to market momentum. When an upward price movement is well under way, buying may be increased rather than lessened. Numerous buyers stock up because they fear to be caught by a further rise. This added buying, in connection with the original cause of advance, may carry prices much higher than expected, but there is still more buying by those who fear that prices are "going out of sight." When this buying is done there is a lull. Heavy supplies are attracted by the high level of prices reached and the drop begins. Many buyers hold off now because they were heavily supplied during the rise or because they expect to be able to buy lower down. Demand is poor and prices decline until bargain hunters appear and regular buyers regain courage; then the demand gradually catches up. Noting the decrease of stocks in sight, more buyers come in and the price again starts upward.

Many typical big moves of the produce market follow this general course. Starting from the top of a rise, there is a long, irregular, wavelike decline. At the bottom there is a quick rebound which may bring values half way to top again. Then a second reaction occurs in which much of the recovery is lost. After that the market starts on new lines, either up or still farther down, according to underlying conditions.

If markets could always be judged from the past, the problem would be simple, but each season has its own features. The best that can be hoped is that judgment based on the past and a forecast of the probable future conditions will be right more often than wrong. The grower as well as the seller of produce is obliged to take risks. Some years all his

well-thought-out calculations will go for naught. The market will go contrary to his hopes and his crop will be disappointing either in yield or in value. That is the danger and fascination of the produce business—all the more reason for him to use carefully what information he can secure in order that in the long run he may have a fair return.

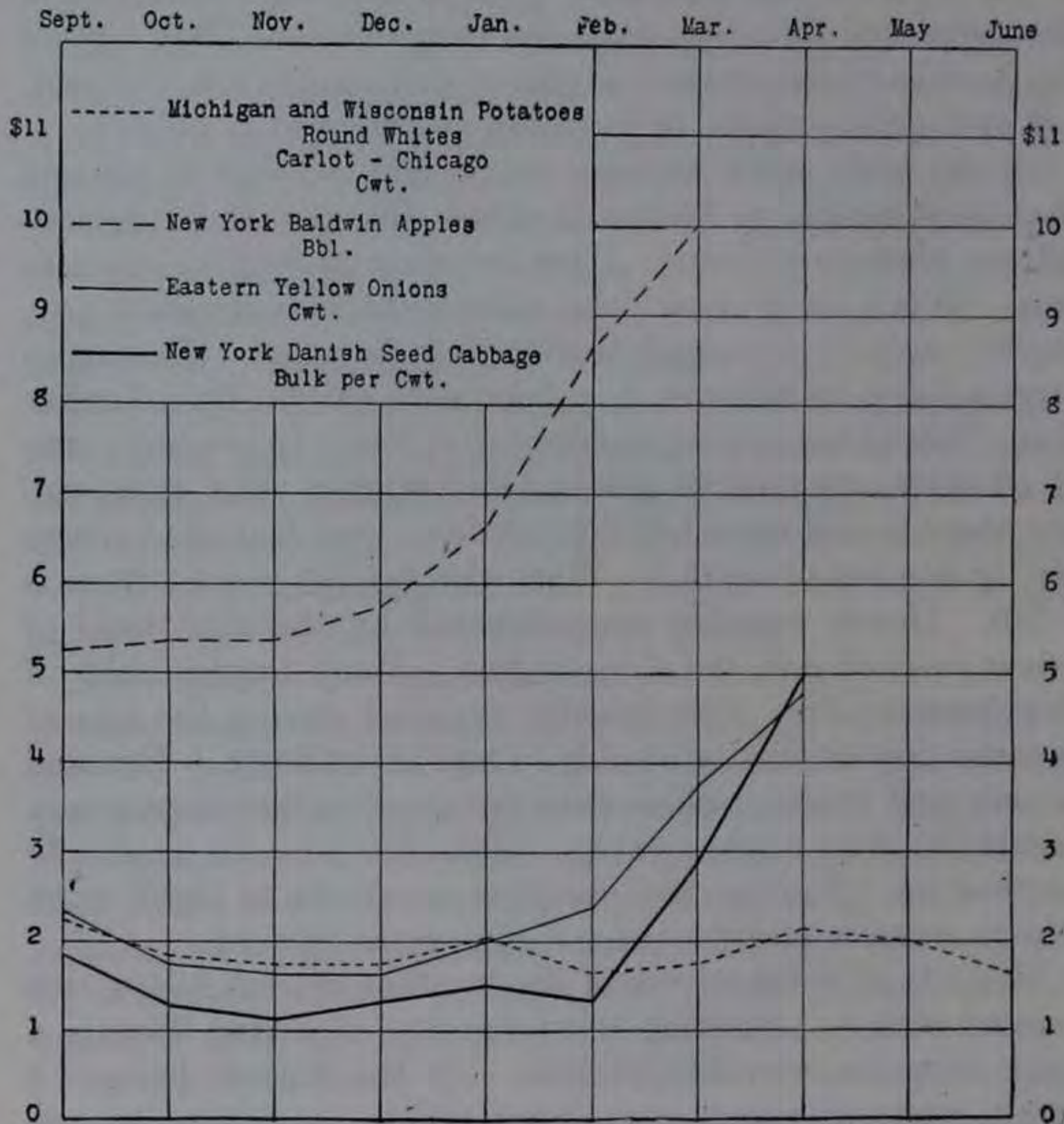

Monthly Average Prices of Leading Crops, Market Season of 1918-1919.

THE CITY AS A MARKET.

In considering a market for produce the first question is, How has it acted in the past? Has it usually paid high prices for the line of produce in mind? What grades and varieties seem to fare best? Is this market often glutted with home-grown or carlot produce or with imports? Is it a diverting point for shipments to other cities? What are the freight charges and the special costs of distribution compared with other markets that might be used?

It is unsafe to judge from high prices that may prevail at a given time. New York is often the highest in prices and soon after becomes the lowest. Boston is often a high-priced market, not considering the cost of freight, but at times is greatly depressed owing to liberal home-grown or Canadian offerings. Baltimore is often low-priced because of the nearness of large producing sections with water transportation, but at times quotes high prices. Middle-western markets may at times be best even for eastern shipments. Sometimes a distant market poorly supplied with the line in question has been the best outlet. All such differences may be quickly reversed by temporary changes. Judgment of probabilities must take into account the whole situation of supply and demand in addition to the day-to-day reports.

#### MARKET NEWS A HELP TO PRODUCERS.

A producer might be tempted at about this point to conclude that shipment, even on consignment, is a business by itself and that he would better sell his crop on the spot for cash. This is, no doubt, the safer course in sections where the local buyers are numerous and where they operate in free competition, but often there is little or no competition and sometimes the buyers hesitate because of heavy supplies on the markets or the doubtful condition of the stock. In that case, producers must consign, either as individuals or through associations.

A large number of growers have no outlet for any considerable surplus produce except through shipment to distant markets. In any event, a close, up-to-date knowledge of the markets helps greatly in checking up the offers of local buyers and returns made by dealers and local marketing associations. The well-informed producer knows the condition of the market and has confidence in his position. Said a Boston apple buyer who had just returned from a business trip in western New York: "We have to pay all the stuff is worth nowadays. The growers are all wise. They know as much as we do. Once in a while we catch a man who has not heard the news, but such fellows are getting scarce." These well-informed growers were in close communication with one another by telephone. Some of them had called up the nearest market station, on the buyer's arrival, and what one grower knew all the others quickly

had by telephone and the buyer was confronted with market news more recent and complete than his own. They would sell their apples, but not below the market, and the buyer was reduced to his rightful position as a holder of stocks and a carrier of risks, but not able to take any undue advantage of the growers.

Numerous letters written by producers to the Bureau of Markets show that the possession of reliable market news vastly strengthens the holder's position. Even the buyer is helped by the service. With the situation well in hand he acts with sounder knowledge and may avoid excessive risks from overbuying or by shipping to overloaded markets. Dealers are quite ready to admit the value and stabilizing effect of dependable market reports.

A grower in Maryland said: "I watched your reports and I noticed that Boston was constantly buying my grade of peaches at a price which would enable me to pay additional freight on all I sent there, so I made about \$70 per car on the proposition."

A grower at Brigham, Utah, writes: "I demanded a price consistent with your reports of market conditions and received it." According to a Massachusetts correspondent the news service "saves thousands of dollars annually for the onion growers of Connecticut Valley."

A railroad agricultural agent in Mississippi declares that the daily market report by wire made possible a combined saving of \$1,000 in one day to growers at three shipping points. "Your office goes a long way toward running down the brokers, dealers, or shippers who are in the habit of making false statements for personal benefit," writes a firm of dealers at Fort Worth, Tex.

#### SAVING THE MATERIAL.

Market reports, carlot figures, and special articles may be kept conveniently for reference in holders sold at the stationery stores or simply by perforating and fastening them together with twine. They should be filed by crops and according to the calendar years for convenience in comparing prices and other conditions, season by season. By reference to these files at critical times in the market, the shipper is enabled to secure a long-range view, with plenty of background to assist in outlining correct estimates of the situation. The special articles which give a long-time summary

of the market for the crop-shipping season and with comparisons for similar crops in preceding seasons are very convenient in making quick estimates of this kind. The value of all this material is greatly increased by keeping it at hand in a form readily available for reference.

#### WHAT THEY WANT TO KNOW

A market station, as a side line, serves as a clearing house for information. All kinds of inquiries, hundreds of them, come from local people who want to know. They write to the station because it is the most accessible Government branch and the general address is easy to remember: "Bureau of Markets," New York, Chicago, or Detroit, as the case may be. These inquiries, except such as refer to the local market situation, which may be answered direct, are forwarded to Washington, where they are referred to the best-qualified technical men in the various departments.

Questions received are a valuable hint regarding the kind of help wanted by producers and consumers in general. It is plain that the information asked for by a few growers must be wanted by others and, if practicable, the material is sooner or later put into shape for general distribution in newspaper articles or official bulletins.

Men in the market stations are in a position to find out more of such needs. They meet dealers and shippers continually in the course of their work and learn what information is most needed. Large producers often visit the stations and the Washington office to submit special problems for solution.

For instance, some Maryland tomato growers, unable to move their surplus, come in to present their troubles and are immediately put in touch with leading canners who handle tomatoes. A prominent New York State potato grower receives information regarding the probable relative market position of his stock if shipped to a distant city. Spinach growers in Texas who apply by telegraph obtain addresses of canners and large buyers. A group of middle-west onion producers are told how to apply for Army contracts. Scores of small growers in widely-scattered sections are advised regarding the possibilities of marketing in small lots by mail or express or motor truck. A manufacturer of fruit juice receives a list of principal shipping points where fruits should be plentiful, and, on the other hand, a

berry grower remote from ordinary markets receives addresses of fruit juice makers.

Requests for lists of dealers need to be answered with considerable discrimination. In large markets the trade specializes to a considerable extent and the list should include dealers adapted to the class of business offered. Small shippers, for instance, should not be directed to firms handling carlots only or to auction concerns. Large shippers should be directed, if possible, to firms which make a specialty of the product intended to be shipped. Even in the separate commodities there is often specialization; some firms, for instance, handle only California fruit, others handle early potatoes but do not take up the late crop to any extent. Some firms that handle northern onions do not deal extensively in the southern Bermuda crop, and some do not handle green onions or bunched stock.

Best results naturally are secured by assisting the shipper to find the class of dealers accustomed to handle, in a large way, the kind of business which he offers. The overworked market station man is evidently not able to take up investigations for individual shippers. He can only send out a classified list believed to be reliable in a general way.

Often request is merely for the official price quotation for a certain day or week, this information being wanted in connection with damage claims or as a check on returns of commission dealers. Whatever the question, somebody in Washington is ready to spend hours, perhaps days, in looking up the facts in order that some unknown correspondent may benefit. Most of the market station men are also producers, or have been connected in some way with handling produce, and they are in a position to realize fully the troubles and problems of the people who write inquiries.

#### READY TO HELP.

The market man is close to the selling end and he is anxious to help.

Market reports on the crop you raise are free. Ask for them.

Keep the reports, reviews, and special articles on file. They will help in following and understanding the markets.

Send the market station man questions. If he can not answer them he knows who can.



# ATMOSPHERIC NITROGEN *for* FERTILIZERS

By R. O. E. DAVIS,  
*Scientist, Bureau of Soils.*

**N**ITROGEN in some form is necessary for the maintenance of animal or vegetable life. No animal or vegetable cell can exist without containing nitrogen in combination with carbon, hydrogen, oxygen, and sulphur. In spite of its essential nature, however, neither animals nor plants can utilize nitrogen unless it is fixed in some combination. Nitrogen in its elemental form constitutes about four-fifths by volume or three-fourths by weight of the atmosphere, but this elemental form must combine with other elements before it can be assimilated. Plants are nourished by the nitrogenous substances contained in the soil and water, and animals by the nitrogenous substances in plants and other animals. The use of fertilizers containing nitrogen is to meet this demand of plants for this essential element.

In addition to being so essential to life nitrogen is the chief and most used element in explosives, and many of the combinations of nitrogen that may be used as explosives may also be used as fertilizers or else by easy transformation may become available to plants as fertilizers. Thus the problem of supplying nitrogen compounds in war is closely linked to the problem of supplying fertilizers in peace. A difference lies in the preparation and application of the products.

## SOURCES OF NATURAL NITROGEN SUPPLIES.

Under natural conditions small amounts of atmospheric nitrogen are continually combining with oxygen and hydrogen to form ammonia and nitrate, and these compounds are carried into the soil by rains and snow to be utilized by plants. Also the action of certain bacteria on the roots of

certain legumes are causing continuously some nitrogen of the air to enter combinations useful to plants. In the life cycle of the plant some of this nitrogen becomes free again when nitrogenous material decays, some is utilized again in other plant growth. Materials of both vegetable and animal origin (such as dried blood, tankage, fish scrap, cottonseed meal, manure) are used to increase the nitrogen store in the soil, but these are insufficient to meet the demands.

The world's principal source of nitrogenous material in the past has been the nitrate beds of Chile. While these deposits are enormous they are not inexhaustible, and it is easily conceivable that a country might be cut off from this supply at a time when nitrates were absolutely essential. This is just what happened to Germany through the operations of the English blockade. But Germany had foreseen the danger and had developed the production of nitrate from artificial sources to such an extent that she could meet her demands without importing Chilean nitrate. Other countries had not progressed so far and the war gave a great impetus to the study of the production of artificial nitrates.

#### COAL A SOURCE OF AMMONIA.

One source of nitrogen in coal-producing countries is ammonium sulphate from coke ovens. Bituminous coal suitable for making coke contains from 0.8 to 1.5 per cent nitrogen, which may be recovered in the gases evolved in cooking. In this country much of the coking in the past has been in the beehive coke ovens, where all the volatile materials driven off by heat are allowed to escape and the valuable ammonia is lost. During the war many beehive ovens were displaced by by-product ovens, and the production of ammonium sulphate in this country rose from 100,000 tons in 1909 to 188,000 in 1913 and 357,000 tons in 1917.

#### INSUFFICIENT SUPPLY.

The consumption of fixed nitrogen in the United States in 1913 amounted to about 140,000 tons, or the equivalent of practically 650,000 tons of ammonium sulphate. The European war produced an unprecedented demand for nitrogen for explosives, and the difference between our production and potential consumption became enormous. This condi-

tion resulted in renewed efforts to establish processes for fixing atmospheric nitrogen in combinations that would be useful for explosives or fertilizers. Such methods have been used largely during the war, but in this country their commercial development has only just begun. Indeed, much improvement in the methods remains to be accomplished.

#### SUPPLY OF NITROGEN INEXHAUSTIBLE.

The desirability of such methods is readily seen when the extent and quantity of the raw material is considered. The atmosphere covers the earth, and above every square mile of the earth's surface there is estimated to be about 21,683,200 tons of nitrogen, while the total area of the earth's surface is estimated at 199,712,000 square miles. That there may be no danger of exhausting the raw material is readily seen from the figures for nitrogen consumption. In 1913 the total consumption of nitrogen for the world is estimated at 787,000 tons, of which 62,000 were produced by some form of nitrogen fixation. In 1917, the consumption had increased owing to the war to 1,231,400 tons, of which 388,000 were produced by fixation methods.

#### CONVERSION OF ATMOSPHERIC NITROGEN.

The conversion of the nitrogen of the air into compounds available for use may be accomplished in several ways, the principal ones of which are:

1. The direct oxidation of nitrogen and its conversion into nitric acid.
2. The combination of nitrogen with metals to form nitrides, which may be treated to furnish ammonia.
3. The formation of cyanides or cyanogen compounds by combination of nitrogen with metals and carbon.
4. The formation of a compound with carbide, producing cyanamid.
5. The direct combination of nitrogen and hydrogen from its elements for the formation of ammonia.

#### THE ARC PROCESS.

The direct oxidation of nitrogen in the electric arc to form nitric acid was the first of the processes to be developed abroad. Many forms of arcs, through which air

## HABER PROCESS.

The Haber process is based upon the direct combination of nitrogen and hydrogen in the elemental form to produce ammonia. The process has to be carried out at a pressure of 100 to 200 atmospheres and a comparatively high temperature, about 550° centigrade. The process was first developed in Germany, and during the recent war it contributed at least one-third of the fixed nitrogen required by that country. In no other country has this process been worked commercially, but a great deal of work has been done toward developing it. It has a number of advantages. The power required is small, the product—liquid ammonia—is readily available for oxidation, and the nitric acid obtained is convertible into fertilizer materials. The raw materials—air, water, and coal—are available in large quantities. The disadvantages of the method involve the use of highly technical labor and the mechanical difficulties of carrying out the operations at pressures of 100 or more atmospheres.

## THE PROSPECT.

From this summary of the nitrogen-fixation processes it would seem that only two are readily adapted to use in this country at present, and when the United States, during the World War, found itself in need of nitrogen these two methods were recommended by a committee of scientists appointed to investigate the fixation processes. As a result two plants were built, known as the Nitrate Plants Nos. 1 and 2, at Sheffield and Muscle Shoals, Ala. Plant No. 1 was completed but never really came into operation up to the time of the armistice. This plant was designed to produce 60,000 pounds of anhydrous ammonia per day. Plant No. 2, for the production of cyanamid, was completed, but operation is suspended pending decision of the method of the plants' disposal. This plant was designed to produce 110,000 tons per annum of ammonium nitrate. The utilization of these plants now becomes a peace-time instead of a war problem.

The intention is to use these for producing fertilizer material in times of peace, and indeed this is the only field in

which so large an amount of nitrogenous products could be used. The problem presents difficulties from a commercial standpoint. In war a workable method is all that is asked, the cost is of little importance; in peace the product must be marketable in competition with other sources of nitrogen.

The great bulk of the product from the plants is cyanamid, and this has several objectionable features as a fertilizer. Because of its irritating effect on men and animals, objection is made to its use. Also, the manner of its application is different from that of other fertilizers. The desire then is to convert the cyanamid into other products not objectionable. This can be done, but the problems to be solved involve the question of costs, and the products must fit into the farmers' experience and occasion least change in agricultural practice.

The United States in 1913 consumed about 140,000 tons of inorganic nitrogen, equivalent to 658,000 tons ammonium sulphate, of which nearly two-thirds was Chilean nitrate. Under the stress of war, with the possibility that shipments of nitrate might be stopped, plants were built with an annual capacity of nearly 50,000 tons of fixed nitrogen. In the year 1917 our by-product coke ovens produced about 80,000 tons of nitrogen, or about 400,000 tons of ammonium sulphate.

Assuming that all the plants and by-product ovens will maintain this production, our total capacity is about 130,000 tons of nitrogen or 611,000 tons ammonium sulphate, close to but less than the total consumption in 1913 in the United States.

As a great agricultural country, we can use much more fixed nitrogen in the future; in fact, the percentage increase in world nitrogen consumption was nearly as great in the four years preceding the war as from 1913 to 1918, despite the large demand for nitrogen in explosives in the latter period. The utilization of these plants will place us in a position where expansion will be easy in time of emergency, and assure us independence as regards a plentiful supply of this most essential element both in war and in peace.

# FARM PRACTICES IN GROWING WHEAT



## A Geographical Presentation.

By J. H. ARNOLD, *Agriculturist*, and R. R. SPAFFORD, *Assistant in Agricultural Economics, Office of Farm Management.*

### SOURCE OF MATERIAL.

THIS geographical presentation of farm practices in growing wheat in the United States is based on reports obtained by the Bureau of Crop Estimates from about 7,000 farmers. Questionnaires were distributed to crop reporters in the wheat-growing regions, and the resulting reports cover practically every county in the United States where the wheat crop is of any importance (see map 1). Where wheat is most extensively raised the records average 8 to 10 per county, and for the entire wheat area the average is about 4 per county. The form of the questionnaire is illustrated on page 125. While not always complete in all respects, on the whole the answers show a serious attempt on the part of the farmer to give as accurately as possible the facts asked for. On many records farmers included notes on these practices, telling how they varied from year to year, depending on weather conditions, etc. Also, there were many notes giving excellent reasons why operations were performed as they were. The authors' thanks are due to the farmers who have cooperated in this work.

These records were read and the data relating to practices in growing wheat were embodied in the accompanying maps.

The practices as reported, while no doubt subject to more or less improvement everywhere, doubtless represent pretty well what the average wheat farmer considers practical and economical under present conditions.

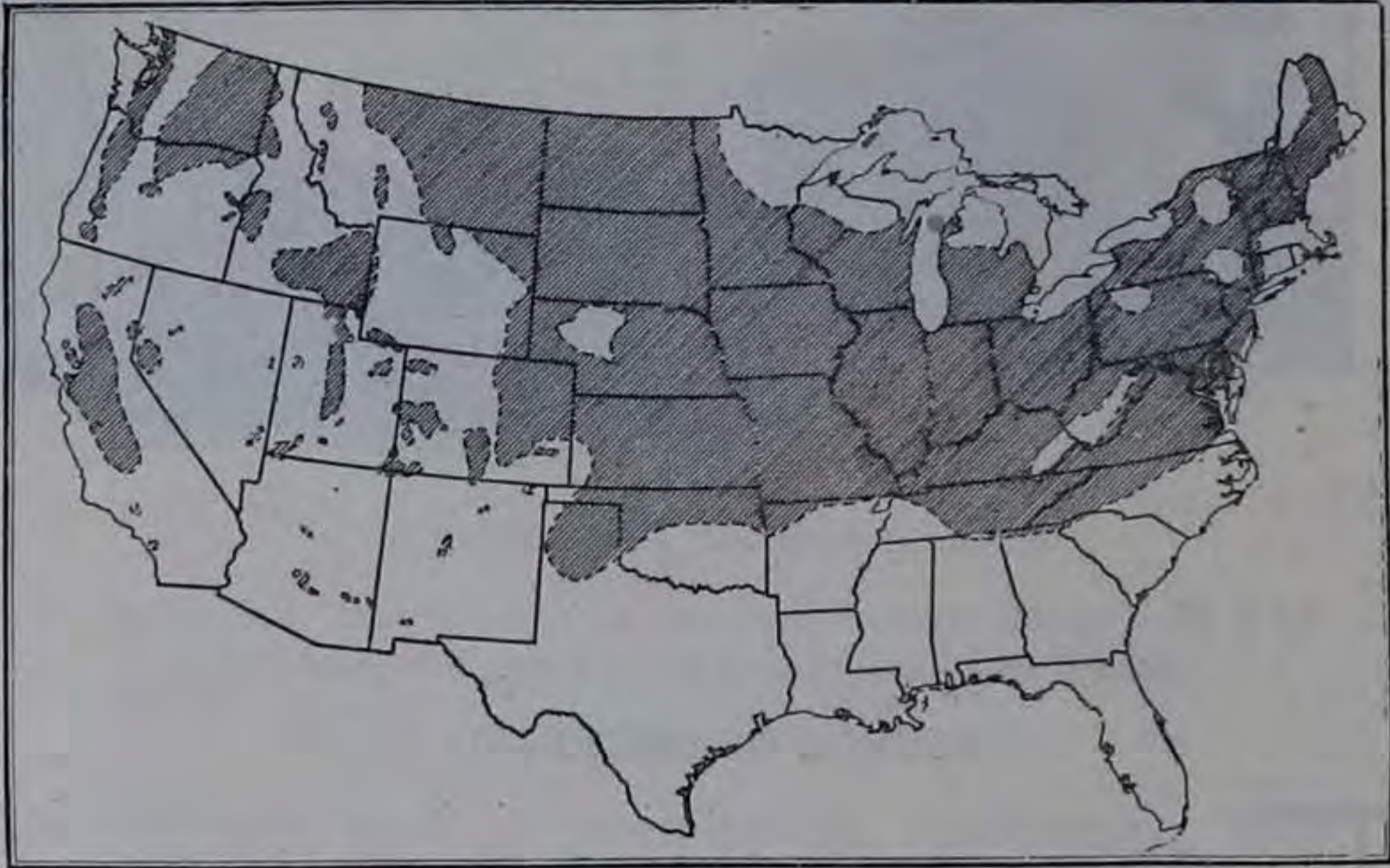

Where the Data Apply.

MAP 1.—Areas covered by reports on farm practices in growing wheat. These reports cover practically all the wheat-growing areas in the United States.

#### WINTER AND SPRING WHEAT.

The labor requirements of winter and spring wheat differ especially in their seasonal distribution, so that for the sake of clearness in presenting the geography of practices the reader's attention is called to map 2. This map shows by means of dots the areas of greatest production in different parts of the United States, and by means of lines the choice of the farmer as to whether he will sow his wheat in autumn or spring. As a rule, winter wheat, when not winterkilled, yields better than spring wheat and permits a better distribution of labor. For these reasons it tends to push northward as far as the climate will allow. The southern limit of wheat growing coincides very distinctly with the northern limit of cotton growing. Conditions under which cotton is produced do not, generally speaking, favor wheat raising. To some extent in Texas, however, wheat is grown in cotton territory.

WHEAT-GROWING OPERATIONS.

The operations required in producing wheat may be conveniently grouped in four divisions: (1) Preparation of seed bed and sowing; (2) harvesting; (3) thrashing; and (4) marketing. Considerable information was obtained on

THE USUAL WAY OF GROWING OR HANDLING Winter WHEAT.  
(later or spring)

Reported by.....

P. O. Huntertown County Allen State Ind.

COMMON OPERATION IN GROWING WHEAT.	Kind of machine.	Usual date farmers begin.	Usual date farmers finish.	Number of men used.	Number of horses used.	Number of acres per 10-hr. day.
plow	14 in sulky	Aug	Sept 10	1	3	2
harrow	2 sec spekes	follow	up plow			
roll	6 ft pul.					
harrow	springtooth	after rain				
" crossways	" "					
roll	and let lay till ready to sow					
harrow	springtooth	Sept 10-12		1	3	10
drill	6 ft disc drill	" 15	Sept 25	1	2	15-30
It is becoming quite a general practice to cover wheat in winter with straw or manure						
cut 7 ft Binder		Jul 1	Jul 10	1	4	12
shock				2		10
Thresh 25-35 per. sep.		Jul 15	Jul 25	14	12	25-30
Market from Machin. Swagons most Farmers put wheat in bins and market when convenient						

A Typical Report as Made out by a Farmer.

marketing, but since methods of delivering grain to the local market are much the same everywhere, no attempt is made to present this information geographically. In reading the discussion of operations which follows there should be kept in mind not only the zones of winter and spring wheat production but certain distinct areas within each



zone. These areas may be defined as (1) the Eastern Area, characterized by a humid climate where wheat growing is more or less tied up with the growing of clover and grasses which have a prominent place in rotations (the eastern portions of the Dakotas, Nebraska, Kansas, and Oklahoma and all the wheat-producing States east are included in this area); (2) the Great Plains Area, where legumes and grasses do not as a rule enter into rotations and where dry-farming methods are used; (3) the Pacific Area, where summer-fallowing prevails, and (4) the Rocky Mountain Area, where wheat is raised in small favorable spots here and there, frequently under irrigation.

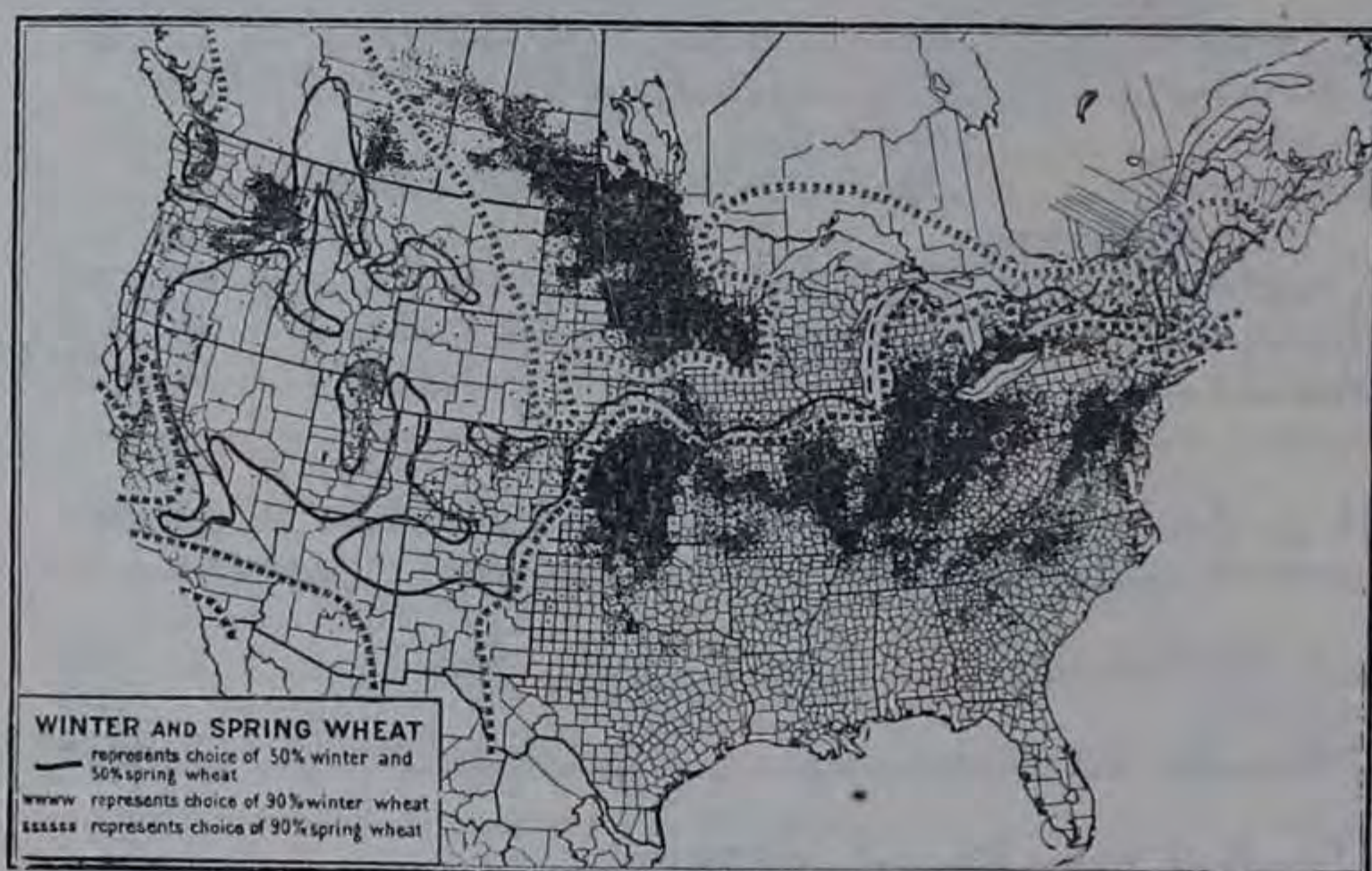

Where Wheat is Produced.

MAP 2.—Distribution of wheat production in the United States and Canada according to the 1910 Census. The heavily-shaded areas show where production is greatest. The heavy dark line on the map shows where the farmer's choice was 50 per cent winter wheat and 50 per cent spring wheat. The line symbolized by "S" shows where the choice was 90 per cent spring and 10 per cent winter wheat. The line symbolized by "W" shows where the choice was 90 per cent winter and 10 per cent spring wheat.

#### PREPARATION OF SEED BED FOR WHEAT AFTER BROADCAST CROPS.

Generally speaking, cultivated annual crops may be divided into two groups, viz, broadcast (or drilled) and intertilled crops. The change from broadcast to intertilled crops and vice versa is practiced in most parts of the United States. This is done in consideration of the value of rotation in maintaining proper soil conditions for growing crops and in the

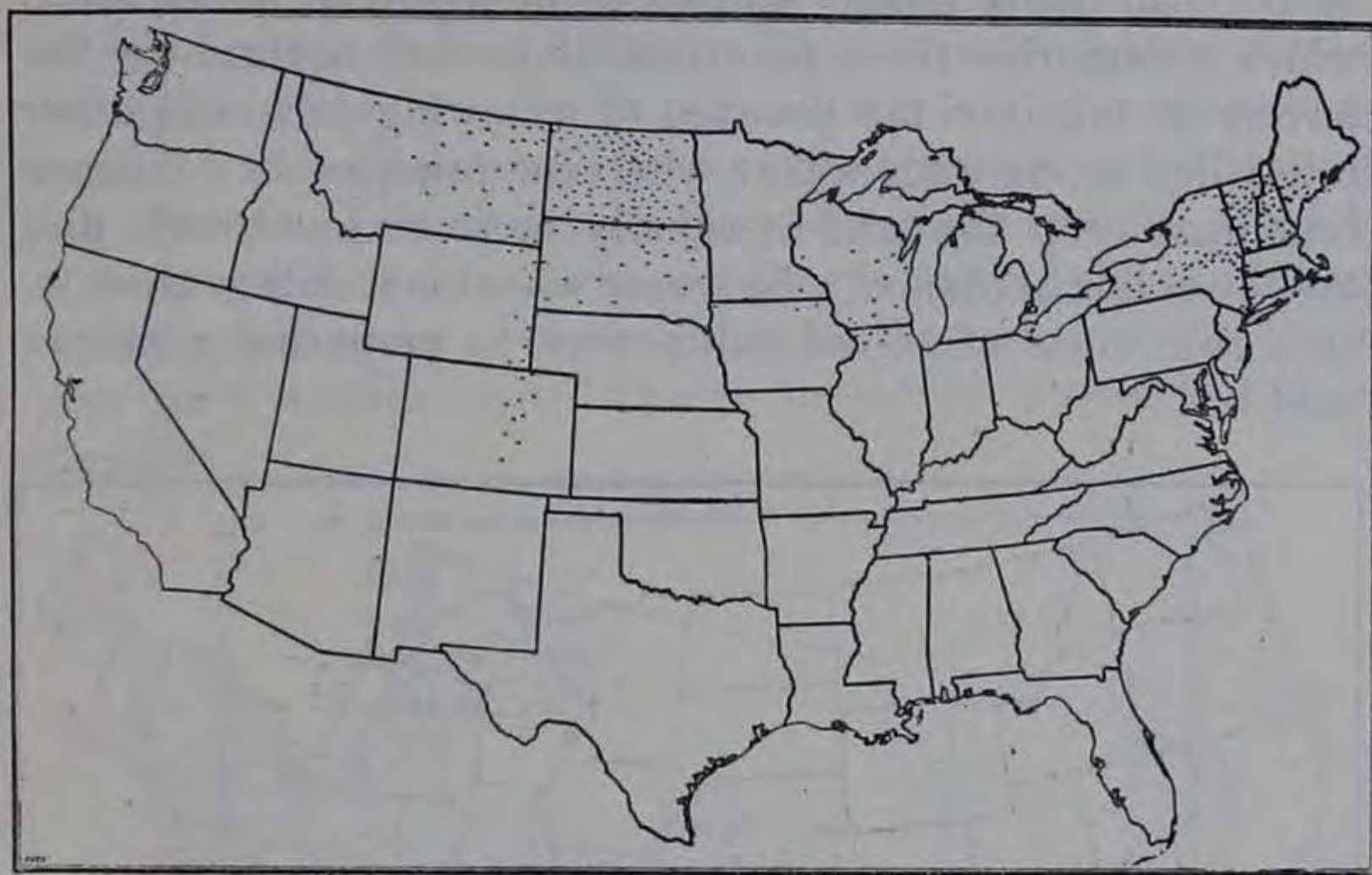

Spring Wheat—Spring Plowing.

MAP 3.—Areas where spring plowing is common in preparing seed bed for spring wheat. The more densely-shaded areas indicate where the practice is most common and the lighter shaded areas where other practices, such as fall plowing or disking cornstalk ground, is also more or less common. See maps 4 and 14.

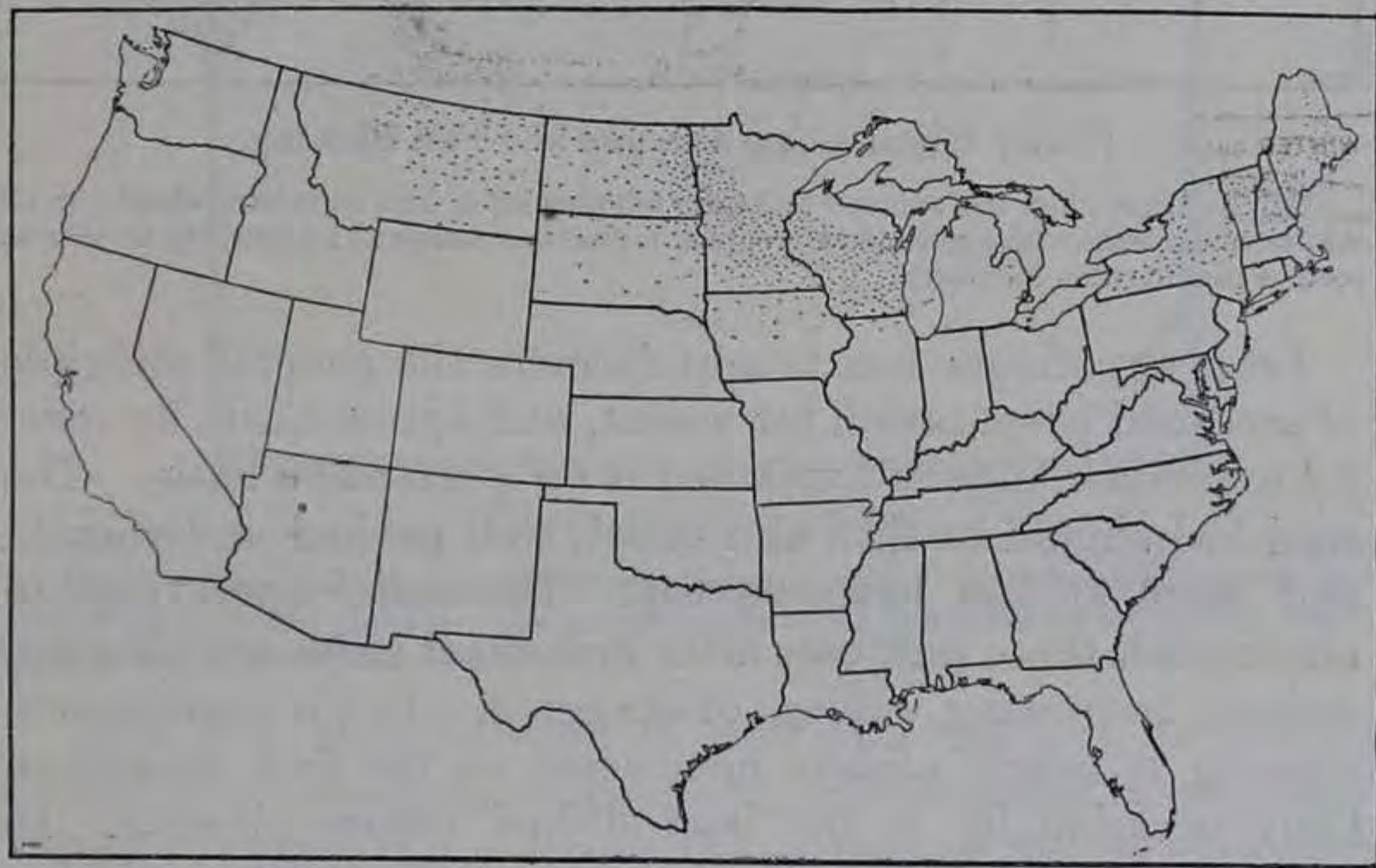

Spring Wheat—Fall Plowing.

MAP 4.—Areas where fall plowing for spring wheat is a more or less common practice.

economical use of labor; and so, as brought out in the maps which summarize these practices, it is very natural for the farmer to fall into the practice of following corn and other intertilled crops with wheat wherever practicable. After a broadcast crop the land is usually more or less weedy and the top soil is hardened. So where wheat is to follow there is, as a rule, need of considerable work in preparing a proper seed bed.

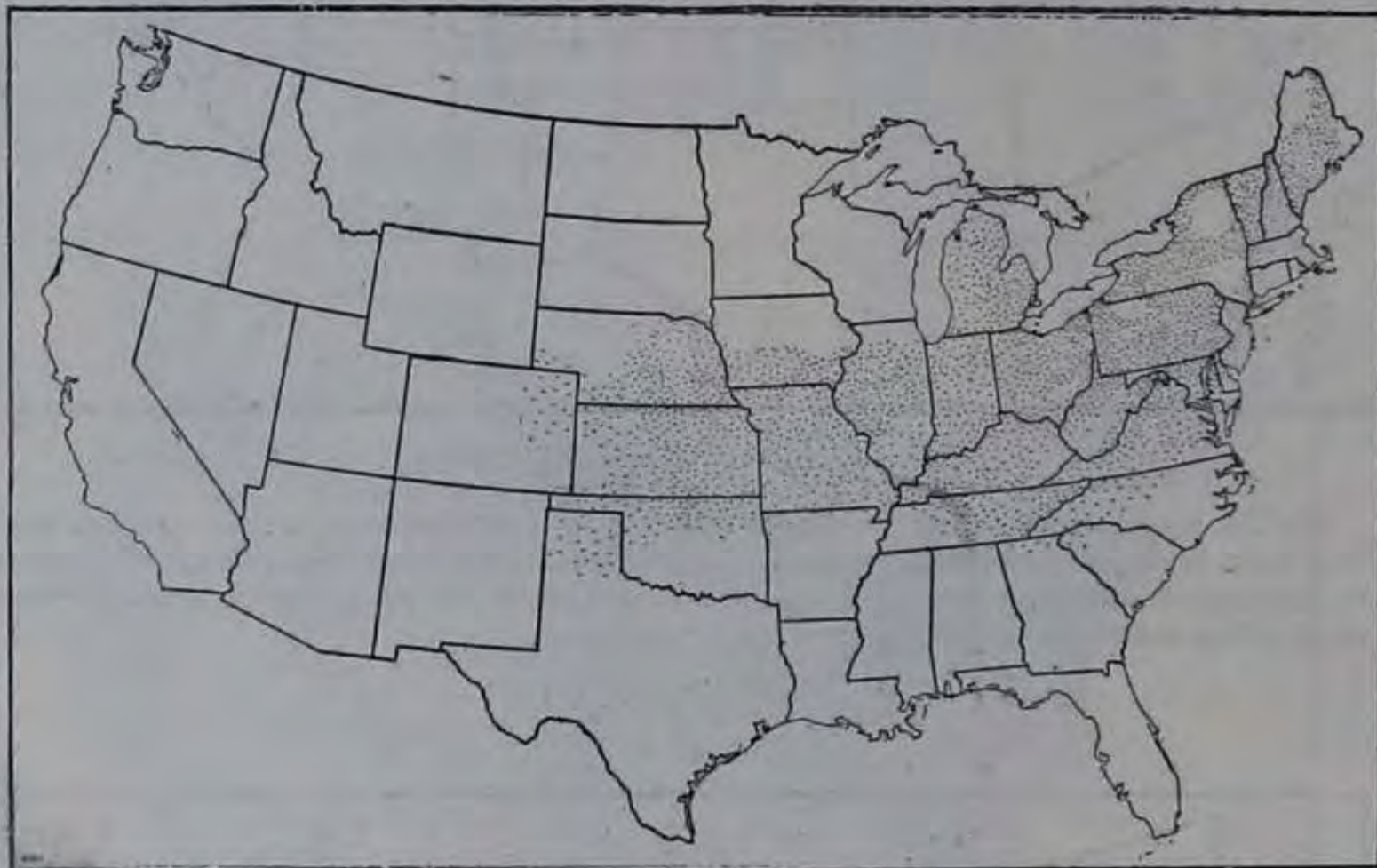

Winter Wheat—Late Summer and Fall Plowing.

MAP 5.—Areas where late summer and early fall plowing is done for winter wheat. In all winter wheat areas where continuous cropping is practiced farmers, as a rule, try to plow as soon as possible after harvest.

Long experience has taught farmers the general principle of seed-bed preparation for wheat, and agronomists by careful experiments have explained it on a scientific basis. The seed bed should be firm and moist, well packed underneath, and more or less loose on top. The usual operations to accomplish these purposes after broadcast crops are plowing, disking, harrowing, rolling, or dragging. In the eastern area plowing is nearly always mentioned as the first operation. Only occasionally is the land disked before plowing. In the Great Plains Area plowing is frequently omitted, disking the stubble or listing taking its place. Sometimes the wheat is drilled into the stubble without any previous preparation.

As a rule no particular sequence is followed in performing the operations before drilling. The farmers that reported pointed out very frequently in notes the fact that operations in seed-bed preparation were not done according to any set rule, that the order in which they were done and the number of times performed varied according to the number and kind of obstacles to be overcome. It is thus obvious that one year may require more labor in preparing a seed bed than another.

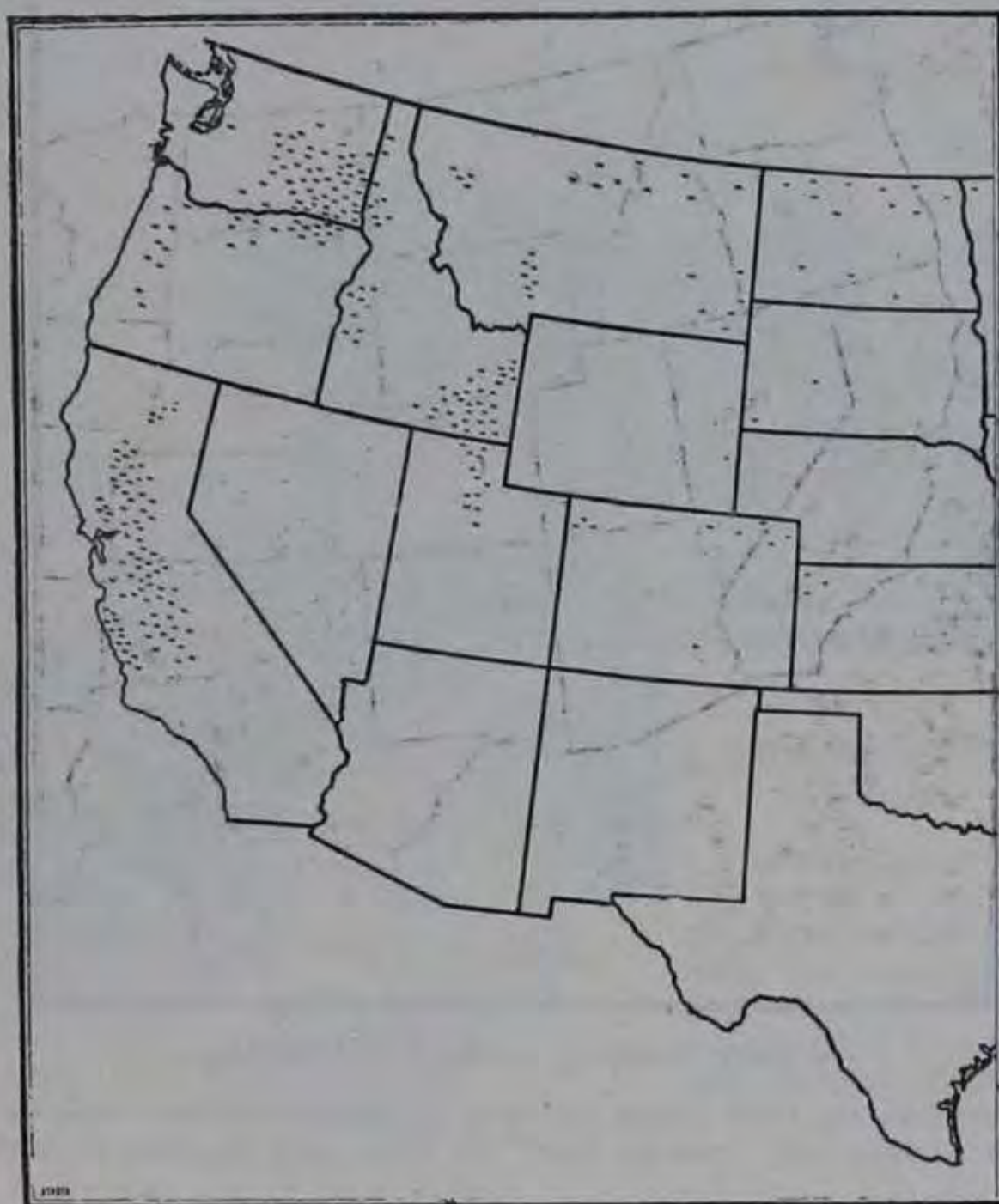

Wheat—Summer Fallow.

MAP 6.—Areas where the summer-fallow practice prevails. The first operation in summer-fallowing is usually plowing. The ground is afterwards kept clean by cultivating, usually with the disk harrow and "weeder."

The disk may be used to pulverize the soil, to destroy weeds, or to pack the subsurface. The harrow is used principally to smooth and loosen the surface, as well as to destroy weeds. The roller is used to pack the surface, the object being usually to bring moisture to the top to start weed growth to be later destroyed, or to hasten the starting of wheat or grass seed sometimes sown with wheat. The plank

drag or similar implement, besides serving the purpose of the roller, is used to crush hard clods and to level the land after rough plowing. In summer-fallow areas farmers report the frequent use of the "weeder" in addition to the harrow and disk. This implement, of which several forms are in use, sometimes operates with a rod or knife just beneath the surface, thus killing weeds without pulverizing the top soil, which under certain conditions should be left cloddy.

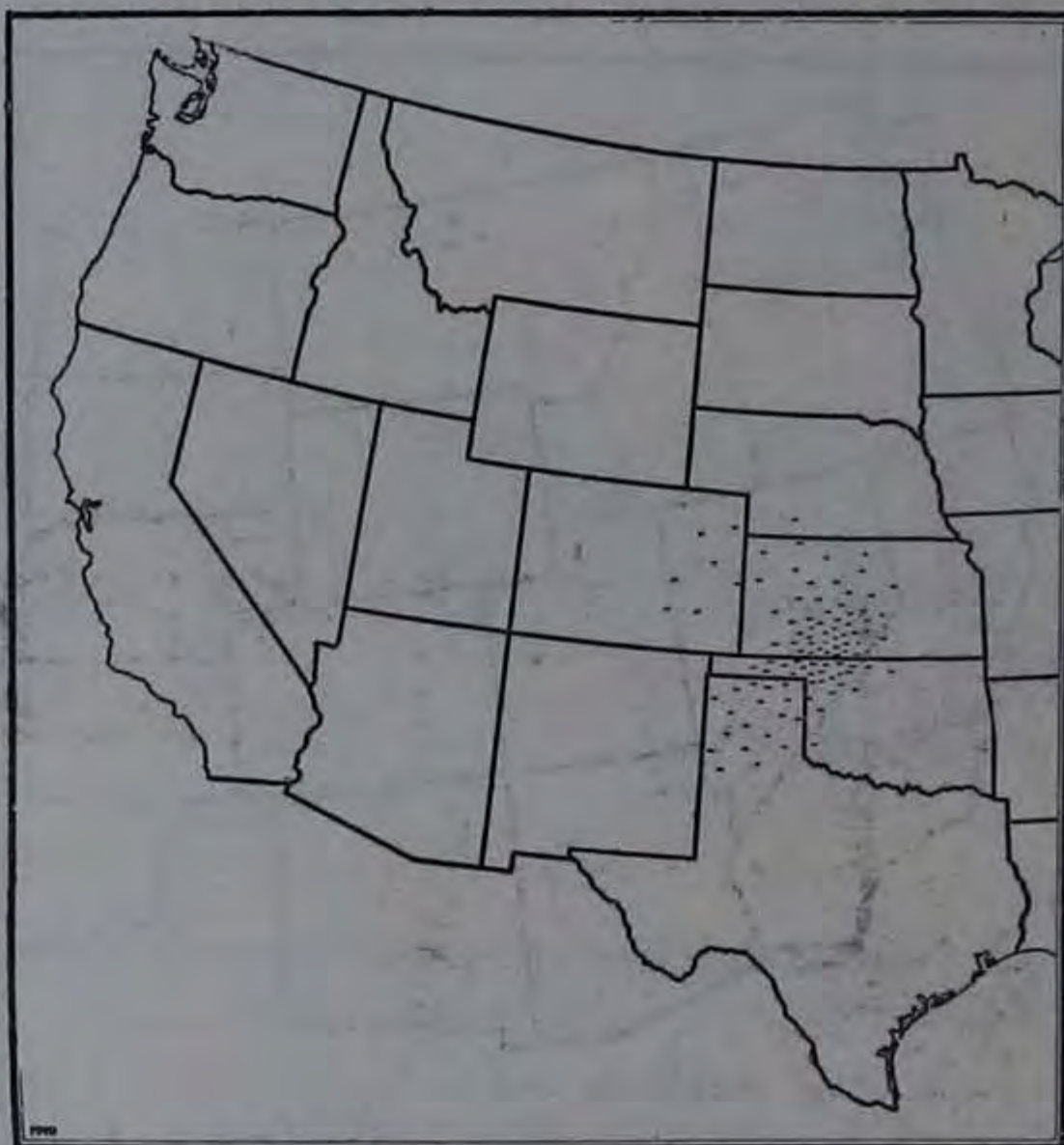

Wheat—Listing Instead of Plowing.

MAP 7.—Areas where the lister is used in beginning the preparation of seed bed for winter wheat. Listing and "working down" the ridges takes the place of plowing.

After a broadcast crop, such as wheat, oats, or barley, the ground is usually plowed either in the spring or fall. In the dry, short-season areas of the spring-wheat zone, spring plowing (not including "summer-fallow" plowing) was more frequently reported than fall plowing, while eastward in Minnesota, Wisconsin, and the New England States fall plowing is more commonly mentioned than spring plowing (see maps 3 and 4). In the more northern or high altitude areas the season for fall plowing is comparatively short. Besides, in these higher and drier areas it is obvious that

stubble and weeds left on the ground during the winter may serve to catch and hold the light drifting snows that would ordinarily be blown off the plowed ground.

In the humid areas of the winter wheat zone, where continuous cropping is the rule, the aim is usually to plow after a broadcast crop as soon as possible after harvest in order to check weed growth and to conserve moisture (see map 5).



A Lister in Operation—  
Kansas.

The lister leaves alternating furrows and ridges. The ridges are later "worked down" and cross-harrowed, after which the wheat is drilled. This implement is also used in planting corn.

Where summer-fallowing is practiced, plowing is done in the fall, winter, or spring according to locality and conditions of soil and weather (see map 6). In California more fall and winter plowing was reported than spring plowing, while in Washington spring plowing for summer fallow was much more frequently mentioned. After plowing, the ground is cultivated with such implements as the disk, harrow, and weeder in order to check weed growth and to conserve moisture. Where this method is an established

practice, a wheat crop usually alternates with summer fallow, thus providing a crop once in two years. In some places, however, the land is summer-fallowed only after two or more years of continuous cropping.

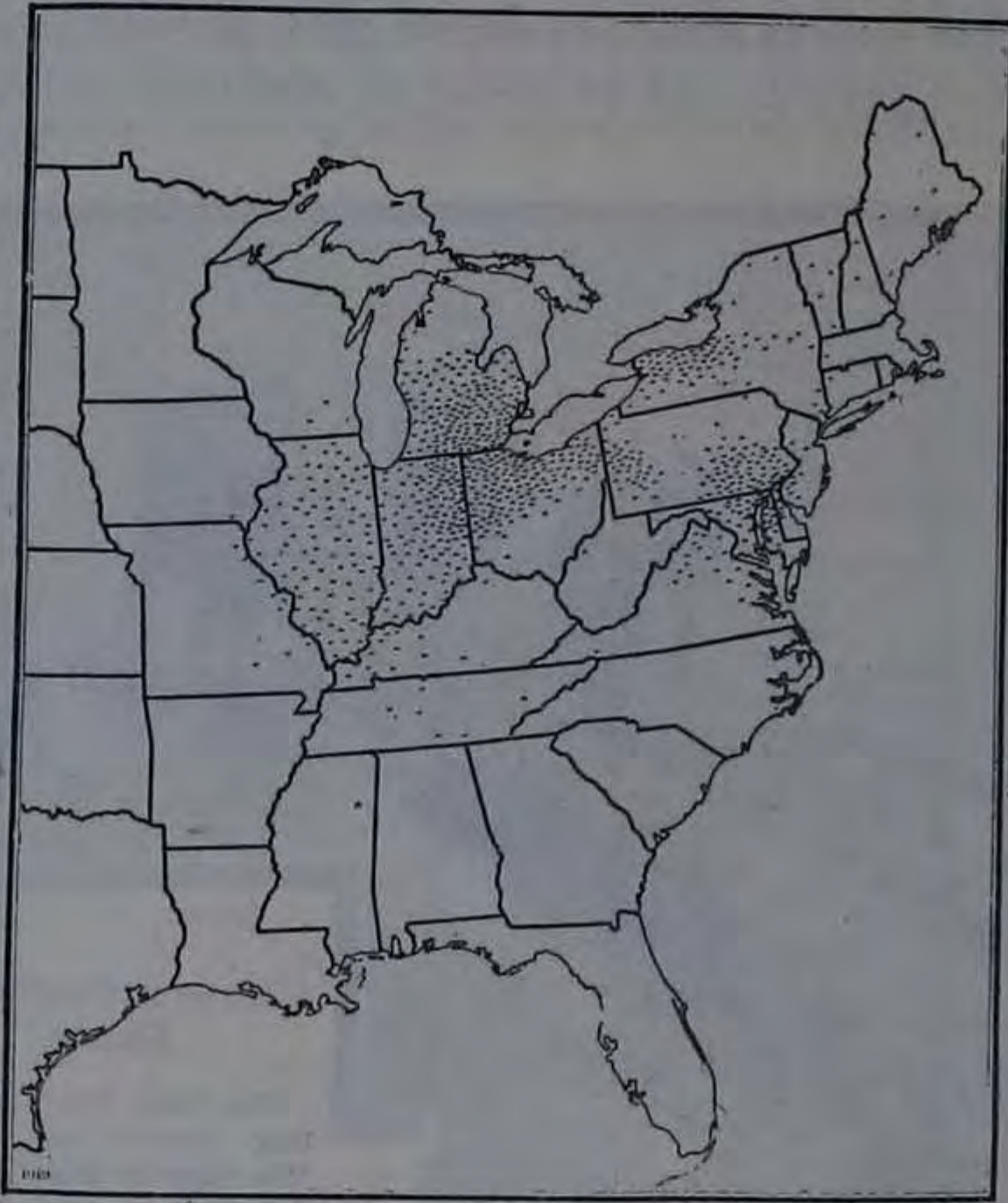

Wheat—Rolling Seed Bed.

MAP 8.—Areas where it is a common practice to roll the seed bed for wheat. In some places drags of various kinds, such as the plank drag, are used instead of the roller.

In portions of the Plains Area listing takes the place of plowing to a considerable extent (see map 7). The lister (see page 131) is an implement that "cuts and covers," but is effective in checking weed growth, in conserving moisture, and in preventing soil blowing. The lister, however, leaves the surface in alternate furrows and ridges so that a special operation is required to level the surface and loosen up the ground left unturned. This is usually done with a "disk sled" or cultivator, after which the ground is cross-harrowed just before the drill. Listing is much more common on light sandy soils than on heavy soils. About the same amount

of labor is used in listing and sledding down ridges as is used in plowing. Taking into consideration, however, the fact that early plowing or listing increases the yields very materially, an economic advantage is gained by the use of the lister in that with the same crew twice as much ground can be covered in a day as with a plow.



Wheat—Planking or Floating Seed Bed.

MAP 9.—Areas where the plank drag and other similar implements for smoothing and packing the seed bed are commonly used. For soils that tend to form hard clods after plowing, or for stony ground, the drag is usually more suitable than the roller.

In all areas where either spring or fall plowing is done, other operations follow, such as disking and harrowing, and frequently rolling and dragging. The frequency and number of such operations after plowing are to a large extent determined by climate and soil conditions and the general type of farming. In northern Ohio, southern Michigan, and northwestern New York, for instance, each of the operations mentioned above is frequently done several times in preparing a single seed bed. Rolling is often done after drilling and again in the spring to pack the soil after it has been heaved



by frost. On the other hand, on wheat farms in the Plains Area or even in the Pacific Area, where summer-fallowing is common, much less work is done after plowing. Neither the roller nor the plank drag is used to any extent in dry farming, since where this method is used a more or less loose, rough, or, in some cases, cloddy, surface has been found to be better than a smooth packed surface. Map 8 shows where the roller is in common use. The plank drag,

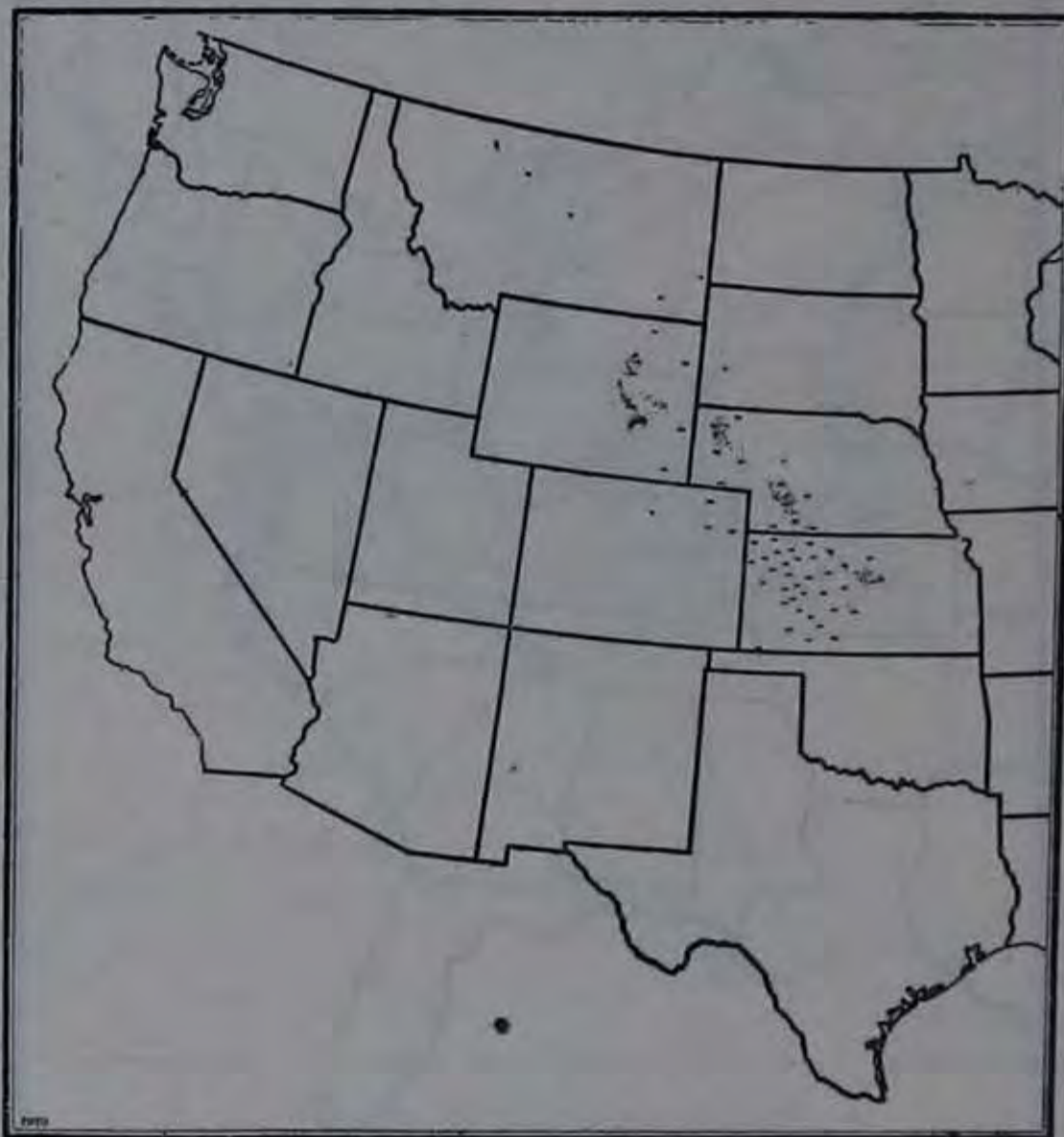

Wheat—Disking Small-Grain Stubble Instead of Plowing.

MAP 10.—Areas where disking small-grain stubble is sometimes practiced instead of plowing. As a rule, when adopting this method, the cleaner stubble is selected.

of which several types exist, serves to a large extent the purpose of the roller. Even in the irrigated districts of the West only a few reports mentioned the roller. While this implement is used wherever the roller is found, it seems best adapted to the more southern parts of the humid winter-wheat area (see map 9). Here the wheat soils are usually heavy and easily form hard clods, and the land is often stony—conditions which call for the drag rather than the roller.

One reason why surface packing is so common in the Eastern Area is that here in fitting the seed bed for wheat it is frequently at the same time fitted for a meadow to follow wheat, so that better to insure a stand of grass the ground usually needs firm packing near the surface; also a smooth surface is desirable when cutting hay. The roller and plank drag are implements which accomplish this purpose quite satisfactorily.

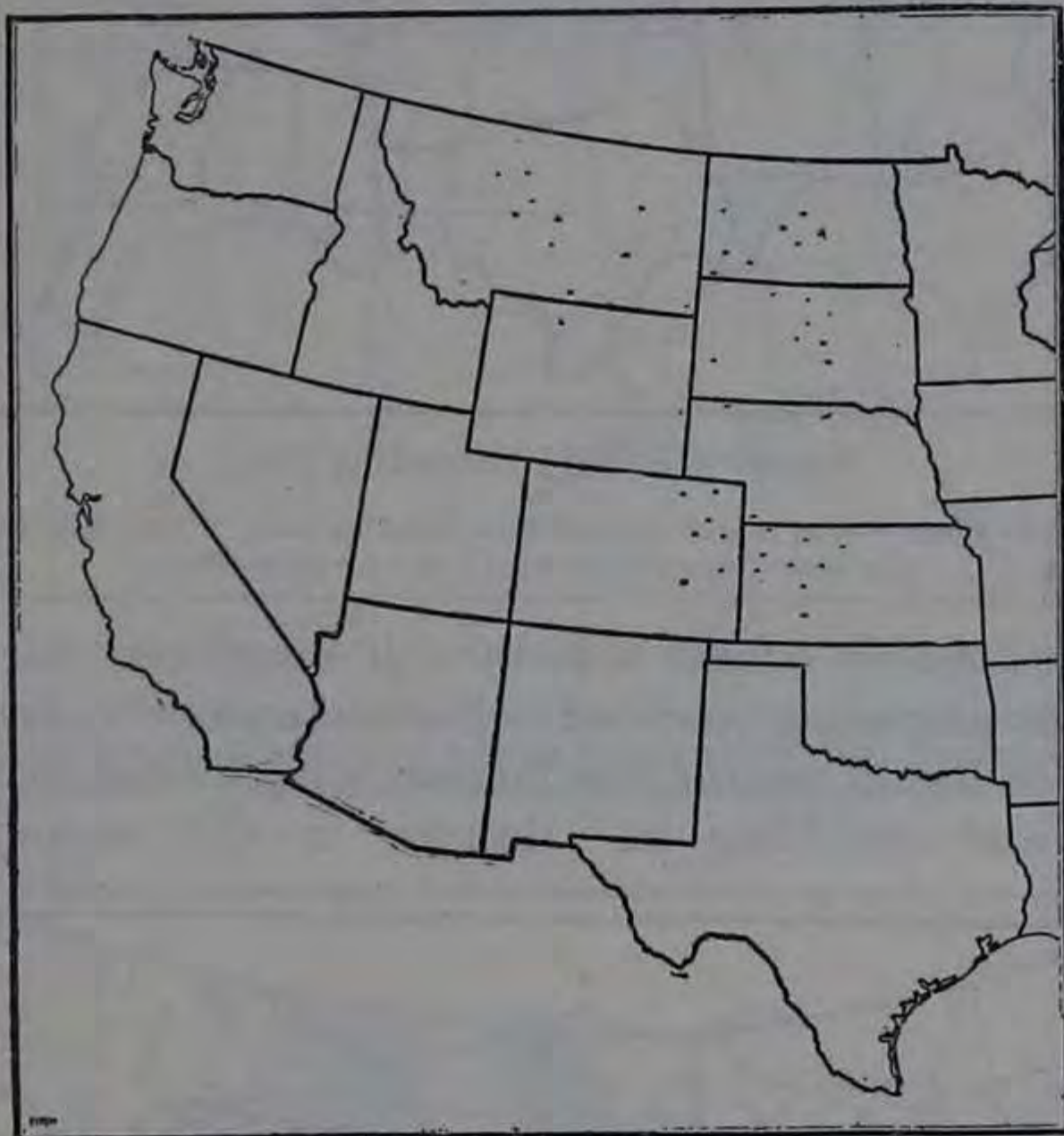

Wheat—Drilled in Small-Grain Stubble.

MAP 11.—Areas where farmers sometimes “stubble in” wheat with the disk drill, without any previous preparation of seed bed. Doing this is not generally considered a good practice, but on clear land it often proves economical.

Disking stubble and “stubbling in” are common practices after broadcast crops in the Plains Area, in both the winter and spring wheat zones. Maps 10 and 11 show the distribution of these practices. In places where such practices are common, average yields are comparatively low and crop failures are more or less frequent, and to meet such conditions economically extensive methods are used. Here the farmer usually plows the weediest land, disking stubble that is less weedy, and simply drilling or “stubbling in” the cleanest land. The following of such practices is governed

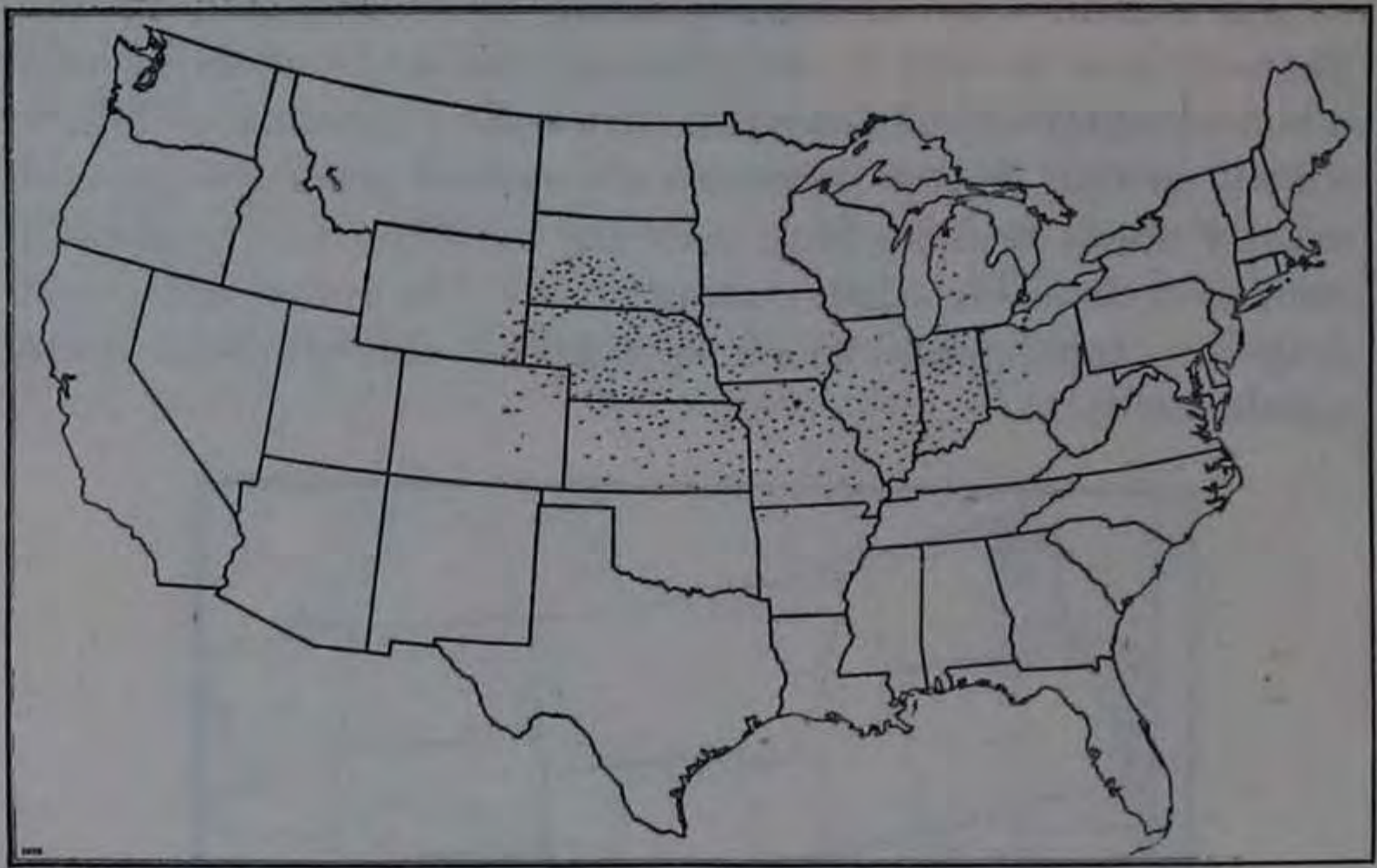

Wheat—Drilled in Standing Corn.

MAP 12.—Areas where winter wheat is drilled in standing corn. Clean cultivation of the corn makes an excellent seed bed for winter wheat.

to a considerable extent also by soil conditions during the period for preparing seed bed. For instance, if it is too dry to plow or list in season, the farmer is compelled to resort to disking and stubbling in. Besides, in this region where

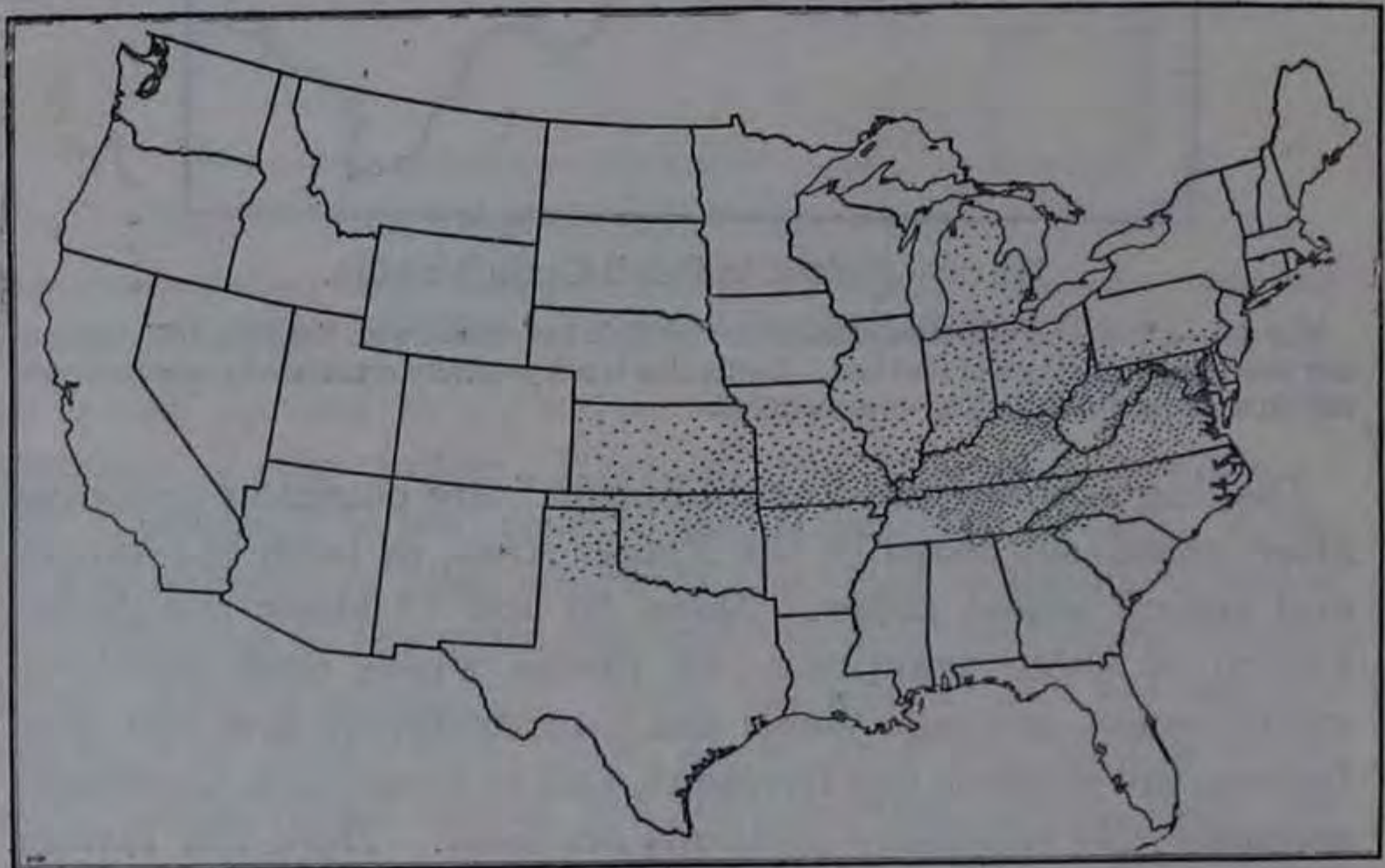

Wheat—After Harvesting Corn or Other Intertilled Crop.

MAP 13.—Areas where it is a common practice to sow winter wheat on ground from which an intertilled crop such as corn, tobacco, potatoes, etc., has been removed.

there are striking variations in climatic conditions, experience has taught that one or the other of these practices is best suited to conditions in any given year.

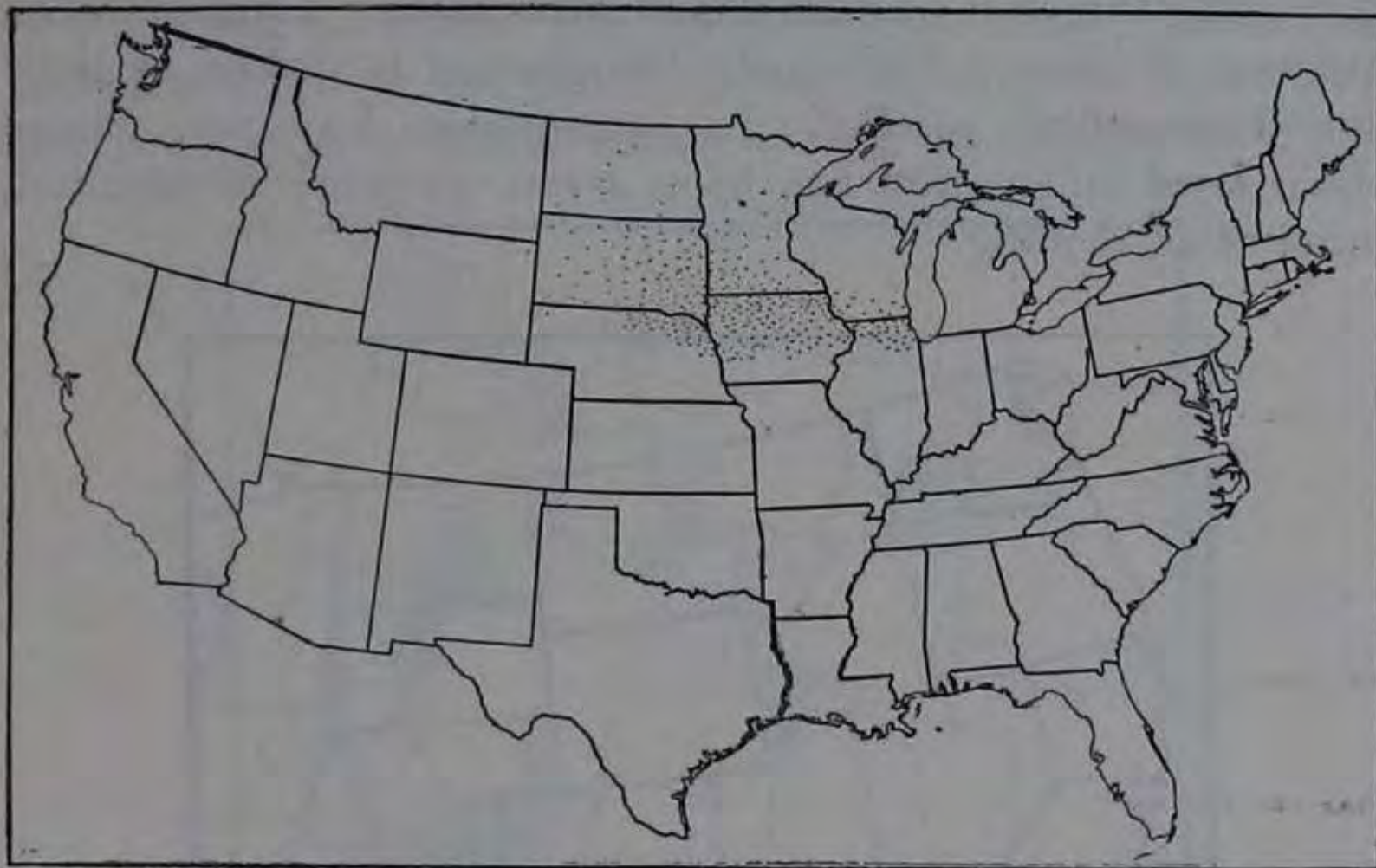

Wheat—Sowing on Cornstalk Ground in the Spring.

MAP 14.—Areas where it is a common practice to sow spring wheat on cornstalk ground. Usually the stalks are cut or broken down before disking and sowing. Sometimes the wheat is simply broadcasted in the stalks, and afterwards disked and harrowed in.

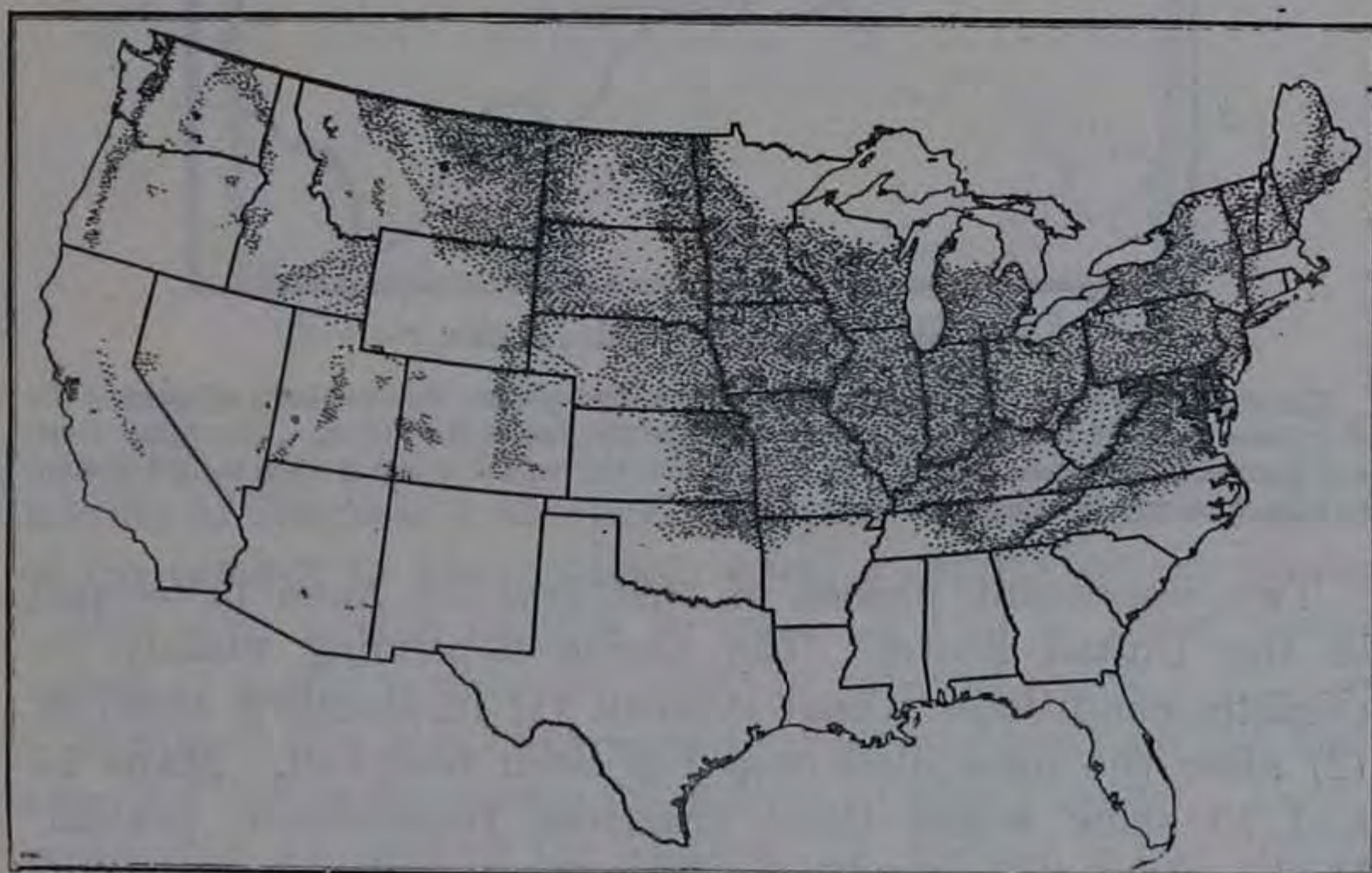

Wheat—Cutting with Binder.

MAP 15.—Areas where wheat is cut with a binder. The binder method is more generally used than any other.

## PREPARATION OF SEED BED AFTER INTERTILLED CROPS.

The cultivation of such crops as corn, tobacco, potatoes, or beans may also be a means of either preparing or partially preparing the seed bed for wheat, thus saving a considerable amount of labor. Ordinarily the ground is disked or harrowed preceding sowing. In some cases, however, where clean level cultivation has been given, no work is required other than drilling.



Wheat—Cutting with Header.

MAP 16.—Areas where wheat is harvested with the header. The header is adapted to the dry plains area and to the summer-fallow areas of the Pacific Northwest. The wheat is cut and stacked in one operation. In the Pacific areas the headed wheat is often hauled directly to a machine and thrashed.

Two important phases of this practice have developed in the United States. The choice depending mainly on climatic conditions, wheat is sown (1) in standing corn, or (2) after the intertilled crop has been removed. Maps 12 and 13 show where these practices, respectively, prevail. Drilling wheat in standing corn is more or less common in the heart of the Corn Belt. The most pronounced centers of this practice, however, lie in south-central Indiana and

in the central portion of Nebraska. The practice extends farthest north in Michigan. Here the climate, modified by the Great Lakes, permits the growing of winter wheat as well as corn. The practice also pushes northward into southern South Dakota, where the winter-wheat zone reaches its northern limits in the Great Plains. Within the belt where this practice is common wheat sowing may begin from the

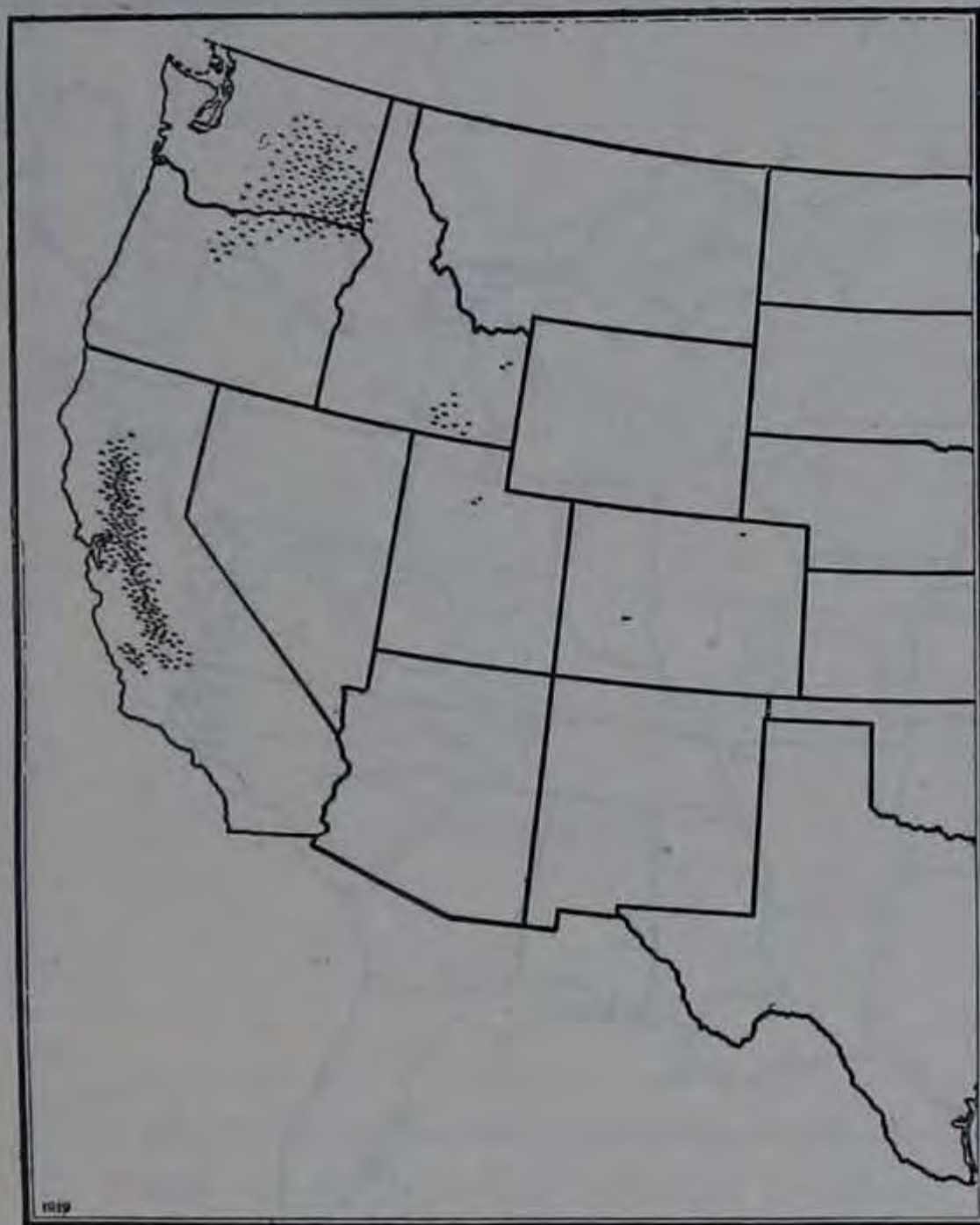

Wheat—Cutting and Thrashing with the Combine.

MAP 17.—Areas where the combine is used. This machine cuts and thrashes the grain in one operation.

middle of August in the northern part to about the middle of September in the southern part, a month or six weeks before corn is ripe enough to husk, or two to three weeks before it would usually be ready to cut and shock.

South of this belt corn ripens earlier and may be cut and shocked before the season for drilling in wheat begins. Here, mainly on account of the Hessian fly, sowing is put off till about September 20 to October 1 and later. Near the Great Lakes region the practice of sowing winter wheat after the

harvesting of intertilled crops pushes north into Michigan, where wheat follows beans or corn put in silo.

In the extreme southern part of the winter-wheat zone farmers usually mention plowing after removing the corn or other intertilled crop. This is feasible, because before sowing time begins the corn may not only be cut and shocked but husked and the fodder removed. Besides, in the more



Wheat—Cutting with the Cradle.

MAP 18.—Areas where the cradle is commonly used in cutting wheat. As a rule, this method is used only when the wheat fields are too small or when there are too many obstacles for the economical use of the binder.

southern area, land in intertilled crops usually late in the fall has become too weedy to be used as a seed bed for wheat.

In the western part of the Great Plains corn is grown very largely with the end in view of preparing a seed bed for wheat. The cultivation of a corn crop serves practically the same purpose as summer fallow. The average yields as a rule are somewhat less than under the strictly summer-

fallow method, but not enough less when considering the value of the corn crop to make the summer fallow the more profitable practice. Besides, wheat sown on corn land is rarely seriously injured by soil blowing, which is more likely to occur on summer-fallowed land.

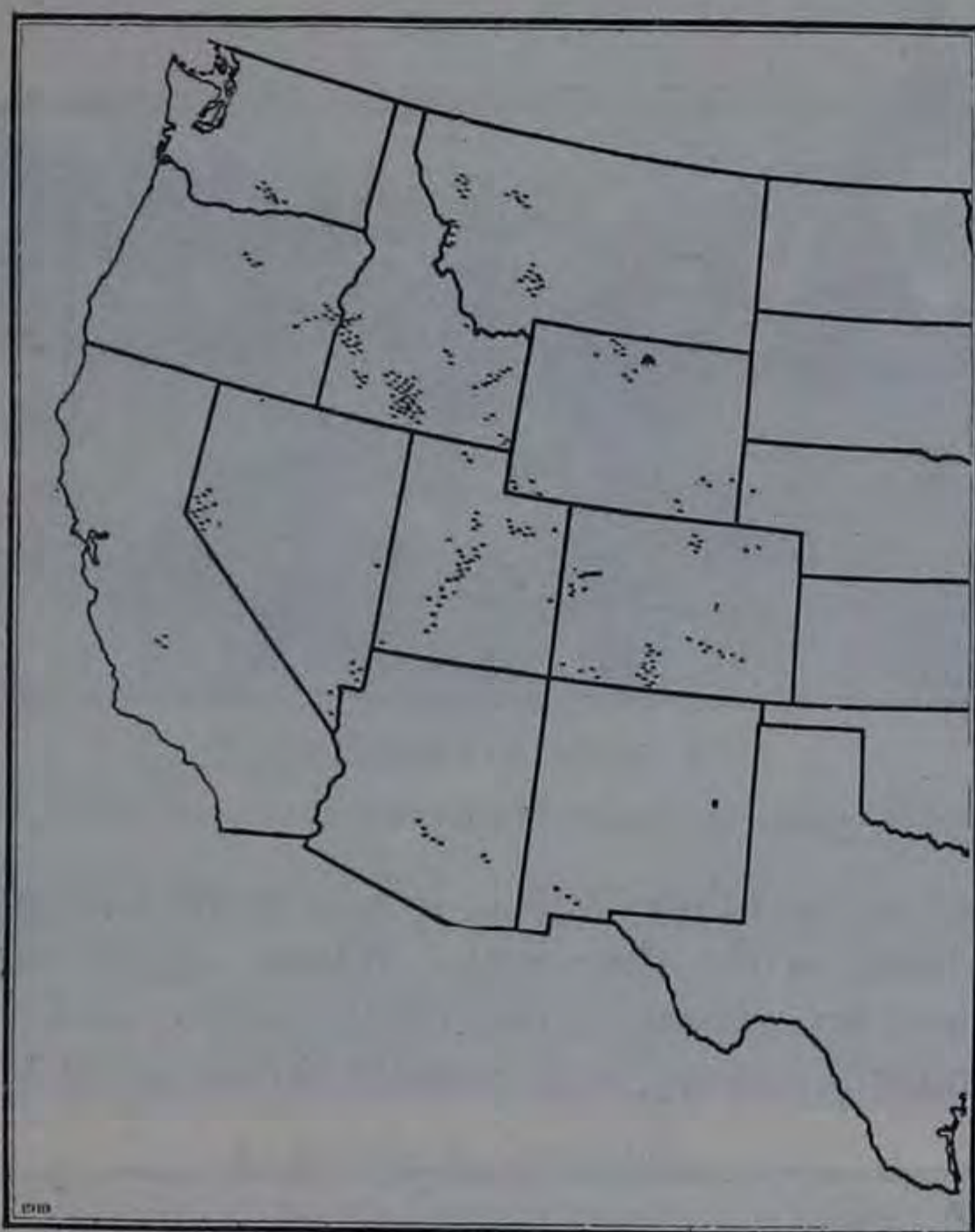

Wheat—Areas Reporting Irrigation Practices.

MAP 19.—Areas where wheat is raised under irrigation.

Spring wheat may also follow an intertilled crop. Where this is done the wheat is either drilled or broadcasted. If on cornstalk ground (see map 14), the wheat is frequently sown broadcast with a seeder, then "cultivated in," or "disked in," and afterwards harrowed. Sometimes the stalks are cut with a stalk cutter, after which the seed is broadcasted and covered by disking or harrowing.

#### DRILLING AND BROADCASTING.

Winter wheat is usually put in with a drill. In the Pacific Area, however, where sowing is done just before the rainy season begins or during the winter, it is frequently broadcasted, generally with the end-gate seeder. Broadcasting



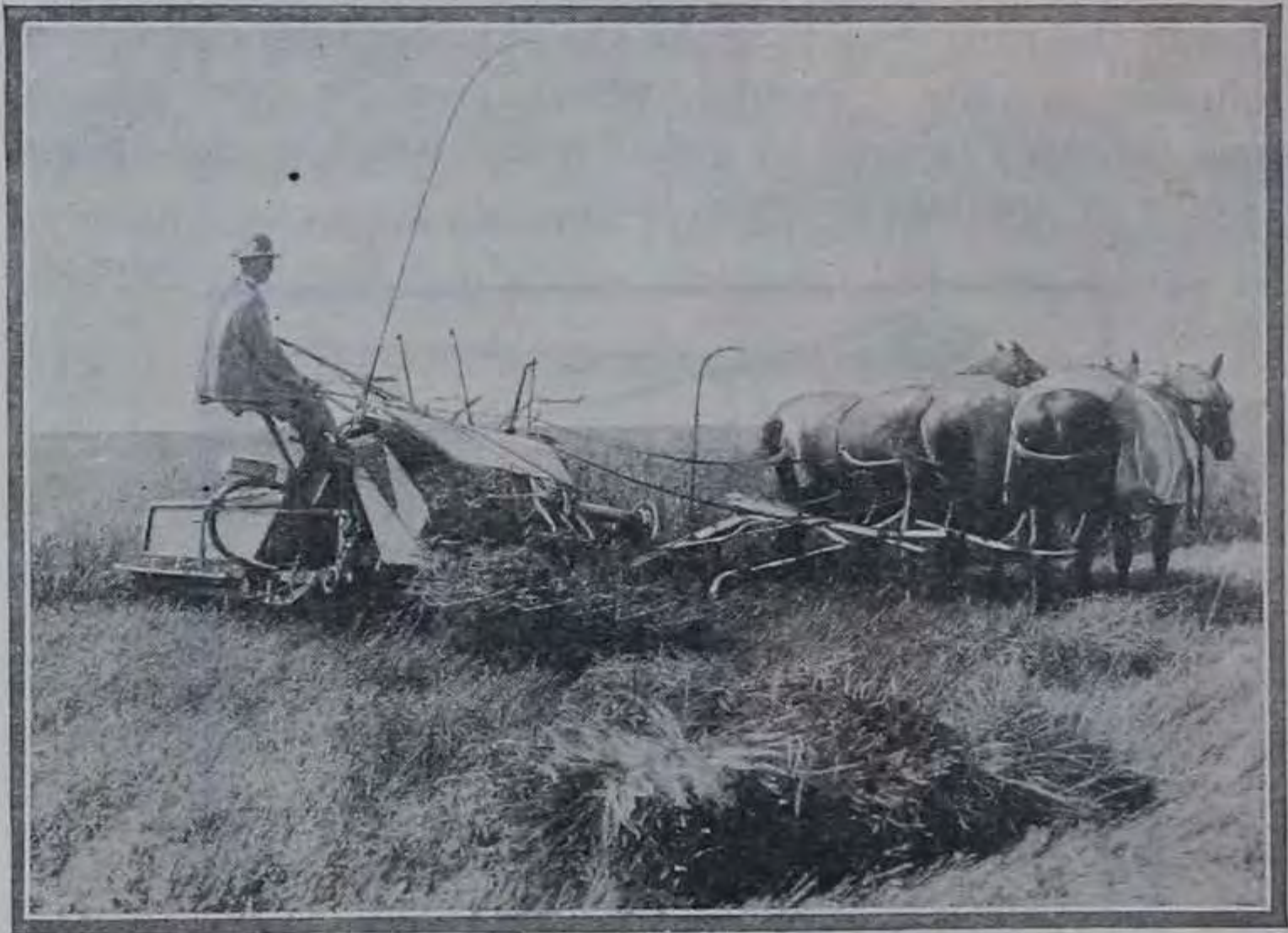

A Binder in Operation.

The bundles are dumped in piles convenient for shocking.

in this way saves labor, but as a rule more seed per acre is required than with the drill. Where small patches of winter wheat are grown in mountain regions and where the land is somewhat stony, it is usually broadcasted by hand.

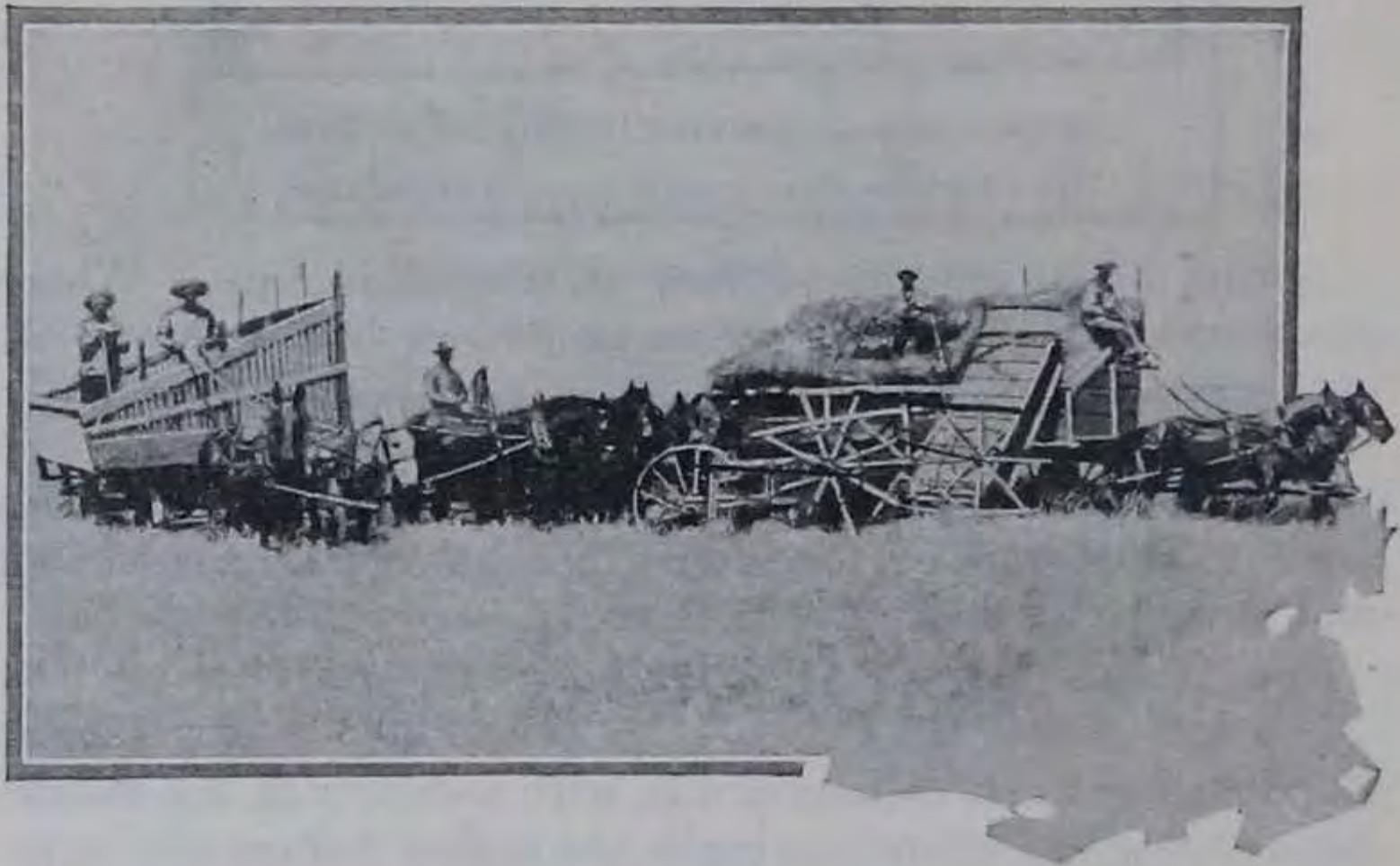

A Header in Operation.

The wheat is hauled to the stack in "barges."

In the spring-wheat zone also, broadcasting as well as drilling is common. Here the wheat is sown early in the spring, when the top soil usually remains moist on account of cool weather and slow evaporation. Under such conditions the chances of starting and growing are sufficiently certain when the wheat is covered simply by a disk or harrow.



A Combine in Operation.

This is one of the larger types. Smaller combines drawn by 10 or 12 horses are in common use. Here the wheat is run into wagons. More often the wheat is sacked and dumped, the bags being gathered and hauled in later.

#### HARVESTING.

Four distinct methods of harvesting are now commonly used in the United States—(1) with the binder, (2) with the header, (3) with the combine, (4) with the cradle. The areas where these different methods prevail are shown on maps 15, 16, 17, and 18.

The binder is used in all parts of the United States. Throughout the Eastern Area, the more humid portions of the Plains Area, and where wheat is raised under irrigation (see map 19), this method is used almost exclusively. With 7- to 8-foot binders on moderately large fields, a driver, 2 shockers, and 4 horses will harvest as a rule 12 to 18 acres

per day, depending on the stand of grain and the condition of the field. In the rougher parts of the country usually 5- to 7-foot binders are used, but the crews are generally the same as in the smoother areas. Here with such machines and crews 8 to 12 acres a day are usually harvested.



A Cradle in Use.

After being cut the wheat is raked into bundles by hand and tied with bands made from the wheat.

In the western part of the Great Plains wheat is usually cut with a header. In the winter-wheat portion of this area it is used almost exclusively. The header is also in common use in the Pacific Area, where the wheat is often headed and hauled directly to a stationary thrasher, while in the Great Plains it is stacked and thrashed later in the season. On page 142 is shown a header crew at work in a Kansas wheat field. The header cuts the grain near the heads and elevates it into a "barge" from which it is thrown on a stack. In the Kansas wheat fields the 12-foot header was reported most frequently and with a crew of 5 to 7 men and 10 to 12 horses, 20 to 30 acres per day are usually harvested. In the Pacific Area the machines tend to be larger, frequently of 14-foot cut.

The crews are also larger, usually 6 to 8 men and 12 to 15 horses, harvesting 25 to 35 acres per day.

The header is particularly adapted to areas where wheat usually develops a short, stiff straw and where the harvesting season is normally dry. Plows, listers, or disks may follow immediately after the header, while in the case of bound grain, stacking or thrashing out of the shock must take place before these operations may be begun.

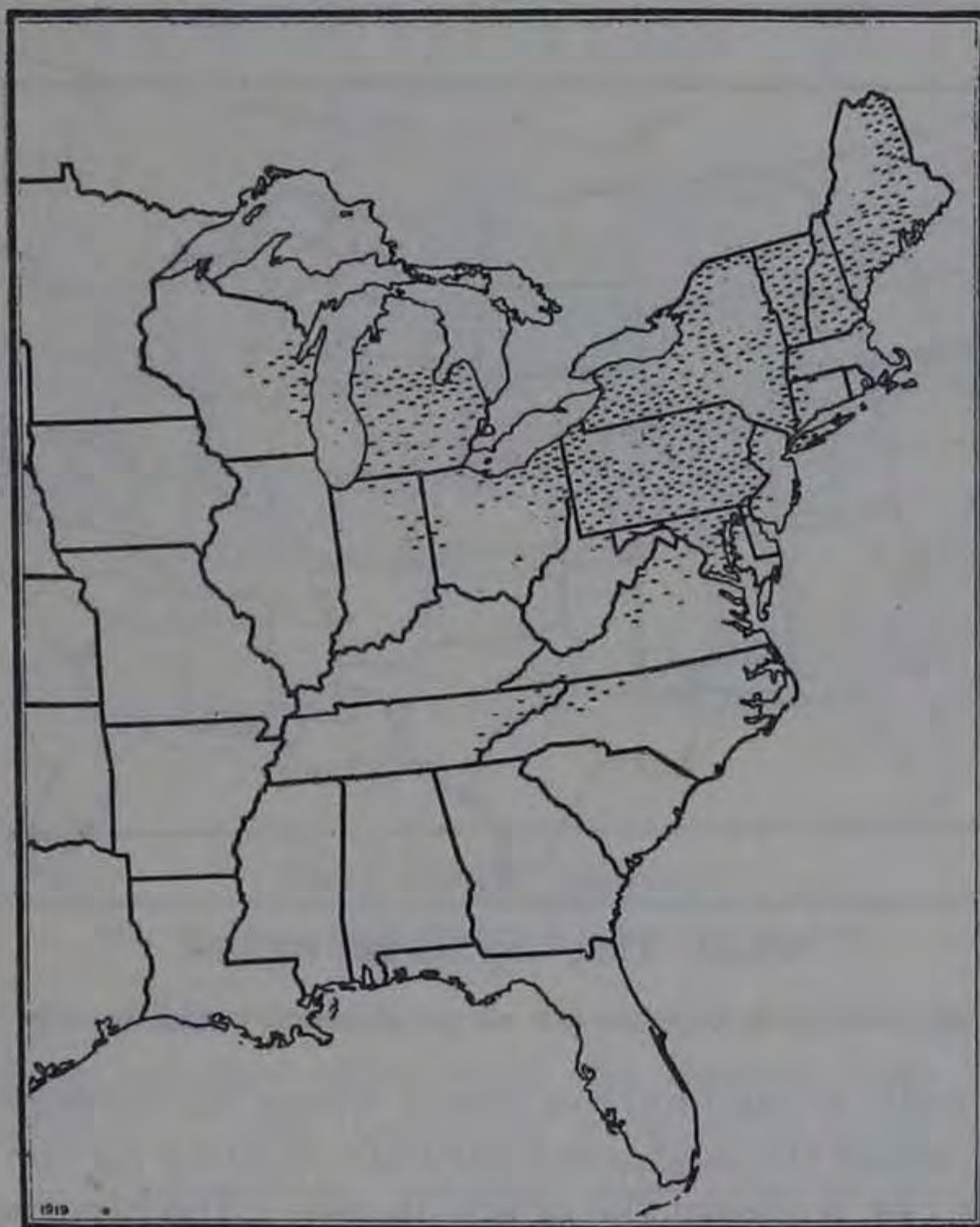

Wheat—Barn Thrashing.

MAP 20.—Areas where wheat is hauled from the shock and put into the barn, where it is later thrashed.

In many localities of the Pacific Area wheat ripens during an almost rainless period and under such conditions the combine harvester and thrasher can be used. This machine harvests and thrashes the wheat in one operation. It is the most economical method of harvesting and thrashing wheat where the climate and topography of the land permit.

One of the larger types of "combine" drawn by horses is shown on page 143. Smaller machines which require less help for operation are coming into general use. The combines mentioned in the reports range in size from 9- to 25-foot cut, the larger ones being drawn by tractors. The smaller crews, 2 to 3 men and 12 to 14 horses, harvest and thrash, as a rule, 10 to 20 acres a day, while the larger machine with crews of 4 to 7 men and 20 to 38 horses may harvest and thrash 25 to 40 acres.

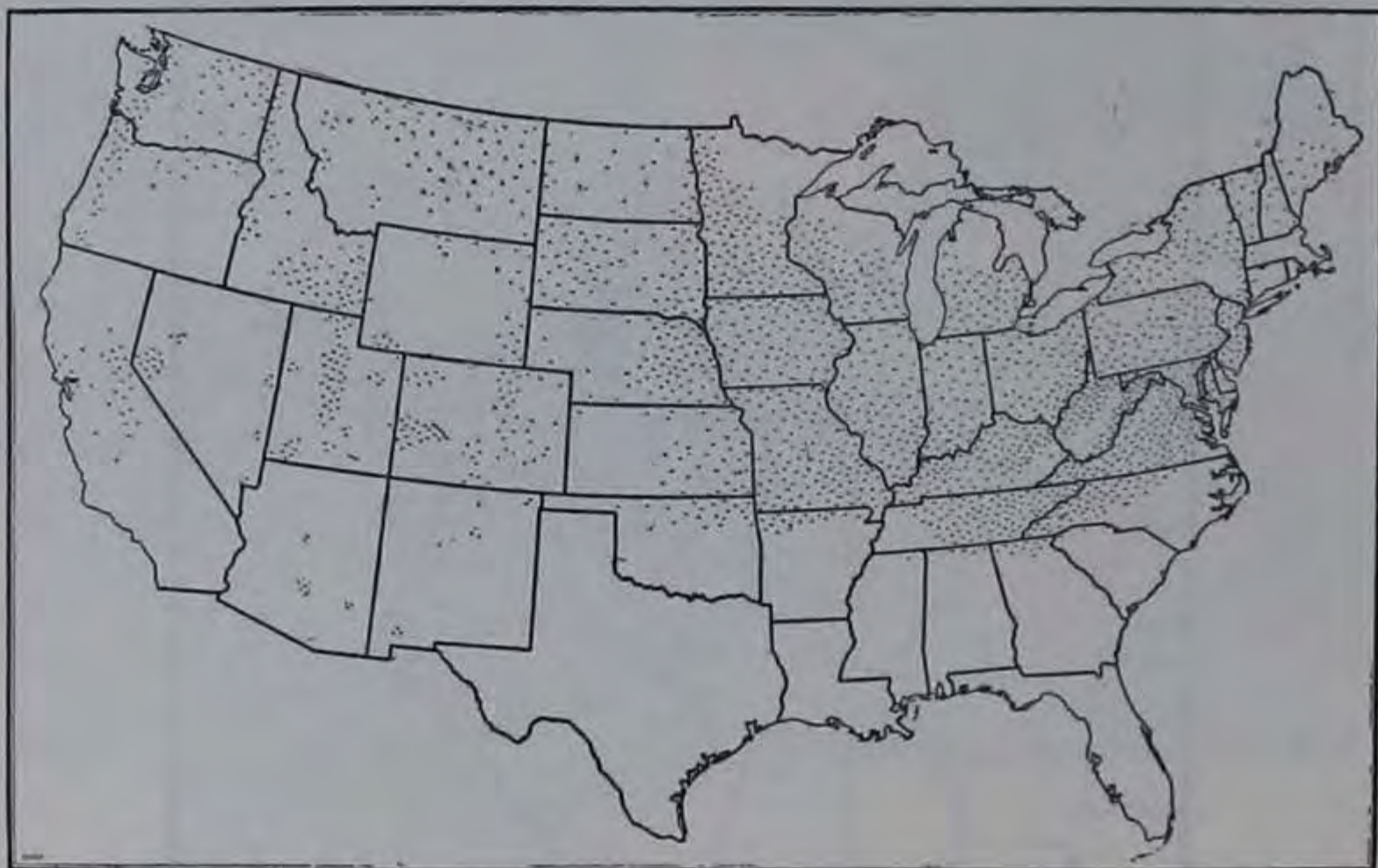

Wheat—Thrashing Stacked Bundles.

MAP 21.—Areas where wheat is usually stacked, to be thrashed later.

The cradle is used only in places where the acreage is very small or where the fields are too rough or stony for the binder. On page 144 is shown the cradle in use. The reports on this practice show  $1\frac{1}{2}$  to 2 acres per day to be the usual amount cut by one man. A crew of 2 to 3 men will cut, bind, and shock from 2 to 4 acres per day.

#### THRASHING.

In all parts of the United States thrashing is done almost entirely by machinery, the power being furnished either by steam or gas engines. A few records from isolated regions mentioned horse-power thrashers and occasionally one was found that mentioned thrashing with a flail. When thrashing is done with the combine, as previously described, the

power is more usually furnished by horses, although engines are in frequent use.

In considering thrashing, however, from the labor distribution standpoint, it is important to classify this operation under four distinct heads: (1) Barn thrashing, (2) thrashing bound grain from the stack, (3) thrashing from the shock, (4) thrashing headed grain from the stack. These practices differ according to fairly well-defined geographical areas.

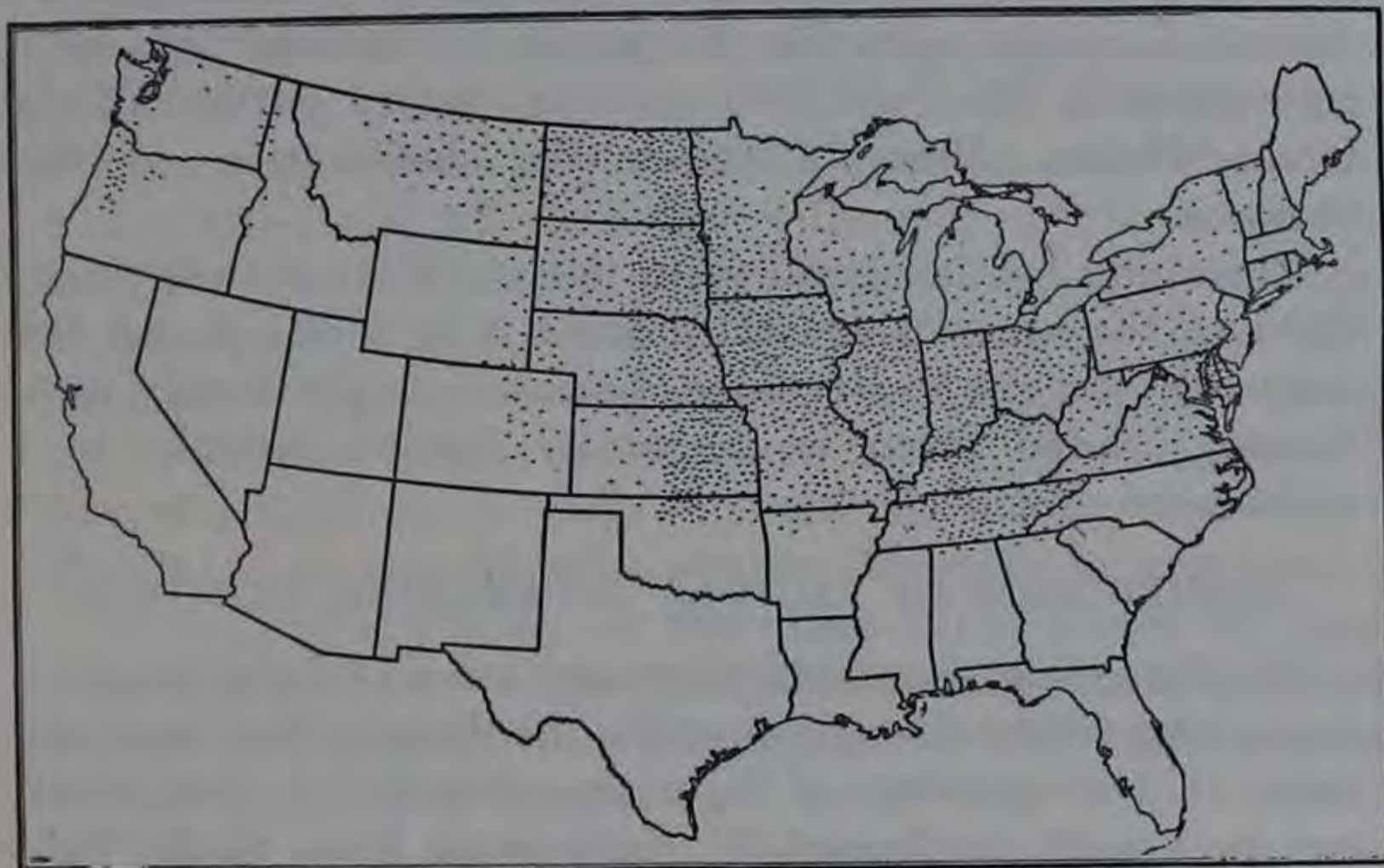

Wheat—Shock Thrashing.

MAP 22.—Areas where wheat is thrashed from the shock.

Map 20 shows barn thrashing to be confined almost wholly to the moister summer climates of the Eastern Area. Also a small amount of barn thrashing is recorded close to Puget Sound, in Washington. As soon after harvest as wheat is fairly dry in the shock, it is hauled to the barn and placed in the mows. Where this practice obtains barns are usually large. The machine is set in the barn and the straw run on a stack just outside, where it is convenient for winter feeding and bedding, while the grain is usually run directly into bins provided in the barn. One of the advantages of this method is that thrashing may be done at almost any convenient time regardless of the weather.

Stack thrashing of bound grain is practiced, generally, over the Eastern Area and in the irrigated areas of the Rocky Mountains. The practice is most common, however, where

dry weather usually prevails during the late summer and fall (see map 21). Frequently where barn thrashing is the rule the entire crop can not be accommodated in the barn, in which case some of the wheat is stacked. Where the acreage of wheat is small and where it is difficult to move a machine about, stack thrashing usually was reported even if weather conditions might favor shock thrashing.

Shock thrashing is done to a greater or less extent in all areas except where the header or combine is exclusively used. As a dominant practice, however, it is reported most frequently in the Corn Belt and the eastern portion of the Great Plains. Map 22 shows the distribution of this practice.

Thrashing headed grain from the stack is obviously confined to the areas where the header is in common use (see map 16). In the Pacific Area, however, as previously mentioned, headed grain is frequently hauled directly to a stationary thrasher.

#### SIGNIFICANCE OF FACTORS UNDERLYING PRACTICES.

The foregoing geographical presentation of farm practices in growing wheat strongly suggests the thought that improvement in the economy of farm practices in growing wheat can be greatly facilitated by considering them in the light of the climatic, soil, and topographic features of the area where they have been developed; also it is obvious that practices suitable for any given area can not be transplanted unmodified to another. The farmer, however, can get helpful suggestions from a knowledge of practices followed in other areas.

The records and notes of the several thousand farmers reporting indicated that some farmers everywhere are seeking to improve their practices in wheat production by the use of labor-saving machinery and by other devices for economizing labor as well as for increasing yields. Economy in the utilization of labor is well illustrated by the practice of sowing wheat after clean-cultivated crops, as when wheat is drilled in standing corn or drilled in after such crops as corn, tobacco, potatoes, or beans have been harvested. Even the practice of "stubbling in" on clean stubble land may under certain conditions be real economy.

The principle of economy and adaptation of methods to local conditions is well illustrated by the several methods of harvesting wheat. Each of these methods previously mentioned is, obviously, the most economical as well as practical for the areas where it prevails. Where there is diversity of conditions to be met in harvesting, there is likewise a diversity of methods. For instance, in the Pacific Area where within short distances there exists a great diversity of climatic, soil, and topographic conditions, three of the four usual methods of harvesting are in common use. In the broad, level river valleys of California where the harvest season is practically rainless and where the wheat will stand till dead ripe without injury from wind or hail, the combine is used almost exclusively. On the edges of these valleys and in the foothills of the mountains, however, where fogs or occasional rains may dampen the wheat, the header and binder are in common use. The same diversity of conditions prevails generally in other parts of the Pacific Area, and likewise similar diversity in practices.

In the Great Plains, on the other hand, where like conditions prevail over wide areas, there is little local diversity in harvesting methods. For instance, within the winter-wheat zone of the Great Plains, harvesting is done almost exclusively with the header. The transition from the header to the binder is somewhat gradual along the eastern edge of this area, where the farmer will frequently own a binder as well as a header, or a binder attachment to the header. Then as one travels farther east the header will disappear altogether, the binder method alone being used.

It is of interest in this connection to notice that a few farmers are using the combine in the Great Plains (see map 17). This doubtless indicates experimental use rather than an established practice in these localities. It is probably safe to conclude that the combine has never secured a permanent foothold in the Great Plains, largely on account of marked variation in weather conditions from year to year and on account of the danger of occasional heavy rains and hailstorms during any harvest season, making it too great a risk to put off cutting wheat until dead ripe.

Listing land instead of plowing is a striking illustration of the development of a practice to solve a difficulty in the distribution of labor and at the same time to increase the



yield of wheat. In the more southern part of the winter-wheat zone in the Great Plains where this practice prevails, alfalfa and sorghum are more or less important crops in addition to wheat. These crops demand considerable attention after, as well as before, harvest and thrashing. Between the beginning of harvest, June 15 to July 1, and about October 1, work on the seed bed for the succeeding wheat crop must be done, as well as harvesting, thrashing, making alfalfa hay, cultivating, and sometimes cutting sorghum. These crops demand attention in their season, and another factor in the problem is that early plowing or listing will usually increase the yield of wheat several bushels per acre. In view of this set of complex conditions, the farmer has found the lister, an implement originally devised for corn planting in the Great Plains, to be a tool well suited to helping partially to solve this problem of labor distribution and better yield. A crew of one man and three horses will cover 5 to 6 acres per day with a lister, while the same crew with a plow will cover but  $2\frac{1}{2}$  to 3 acres. In total amount of labor required, however, there is probably little if any economy, since the listed ground must later be worked down with other implements. The main advantage is that with a lister more ground may be covered early in the season, thus increasing the chance of higher yields. This practice, while at present limited to one distinct wheat-farming area, could possibly with profit be extended to others having similar conditions and problems to meet.

Rolling, or otherwise smoothing and packing the surface of the seed bed for wheat, is frequently thought of as characteristic of especially efficient practices. From the foregoing study it is a fair conclusion that such a practice under dry-farming conditions as a rule would be decidedly inefficient and under certain conditions disastrous. In dry-farming in general the implements used should leave the surface rough and, under some conditions, even cloddy, to prevent blowing and winterkilling. However, occasionally a farmer in these areas rolls winter wheat in the spring with some form of subsurface packer and considers it a good practice.

# THREE CENTURIES OF TOBACCO



By GEORGE K. HOLMES,  
*Statistical Scientist, Division of Crop Records,  
Bureau of Crop Estimates.*

STEPS TO A CROP OF 1,439,000,000 POUNDS.

COLONIAL PRODUCTION.

WHEN Europeans first came to North, Central, and South America and to the West Indies they found the natives using tobacco in various ways. The explorers carried small quantities of tobacco when they returned to their home ports and by example and instruction initiated the use of the plant by smoking in western Europe. Before 1607, the year of the Jamestown settlement, tobacco plants were growing in European gardens from seed brought from America. It was observed that the plant grew in different varieties in the Western Hemisphere. The Virginia plant, known to the Indians as "apooke," is described by Strachey as being poor and weak in comparison with that of the West Indies. Its height was less than 3 feet, its bloom yellow, and the leaf short, thick, and rounding at the upper end. The whole plant was dried over a fire, or sometimes in the sun, and leaves, stems, and stalks were crumbled to powder.

On the Atlantic seaboard of North America tobacco was first cultivated by one of the white race when John Rolfe raised it in his garden at Jamestown in 1612. Cultivation by other members of that colony followed and by 1618 as much as 20,000 pounds was sent to England, where demand and market, although small, had already been established. The export of tobacco from Virginia doubled the next year, and in three years from 1618 it trebled. A half million pounds measured the export in 1627, about 1,500,000 pounds in 1639, about 23,750,000 pounds in 1664, presumably from Maryland as well as Virginia, and with an irregular upward movement the quantity exceeded 107,000,000 pounds in 1770. Exports were small, but did not cease, during the Revolution, after which they rapidly rose to 101,000,000 pounds in 1790, when the estimated production was 130,000,000 pounds.

In colonial times the English navigation laws prohibited shipments of tobacco to any country of Europe, except England, and, eventually, Scotland, to promote purchases of British manufactures by the colonists, and these shipments are all that is known concerning the quantity of the production. With them should be included unknown colonial consumption and undetected smuggling.

#### RECORD OF THE CENSUS.

The first United States census of agriculture, for 1839, found a crop of more than 219,000,000 pounds of tobacco, but in 1849 it was under 200,000,000 pounds. By 1859, it had more than doubled the crop of 1849 and reached 434,000,000 pounds, followed by reduction to 263,000,000 pounds in 1869, in consequence of the Civil War. After that year, production advanced to 868,000,000 pounds in 1899, to 1,056,000,000 pounds in 1909, and to 1,439,000,000 pounds in 1918, the largest crop ever raised, as estimated by the Bureau of Crop Estimates.

#### DISTINCTIVE TYPES.

In the tobacco-producing States, distinctive types of tobacco grow. Cigar types grow north of Maryland and the Ohio River and in Georgia and Florida. Together, they are about one-fifth of the national crop. About four-fifths of

the crop embraces types described as chewing, smoking, snuff, and export types, growing mostly in the Southern States. Less than 1 per cent of the entire crop is unclassified by type.

#### GEOGRAPHIC REDISTRIBUTION.

In the course of time, the relative production of tobacco in the various geographic groups of States has changed considerably, owing to extension to new regions and to changing fancies for some of the types. In 1839, more than one-half of the national crop was produced in the South Atlantic States, or 54 per cent, but the fraction declined to 21 per cent by 1889, with recovery to 35 per cent in 1899, and to an average of 36 per cent in the five years 1914-1918.

The South Central States had second place in 1839, with 38 per cent, and the percentage rose as high as 53 in 1889, and fell to an average of 41 in the five years ending with 1918, or above that of the South Atlantic States. Production has been almost entirely east of the Mississippi River.

Third place has been held by the North Central group since 1839, with nearly the entire production in the eastern subdivision. The fraction increased from 8 per cent in that year to 18 per cent in 1869, since which year it has declined to the average of 14 per cent in 1914-1918.

The North Atlantic States produced less than 1 per cent of the tobacco crop in 1839, but had raised the fraction to 13 per cent in 1879. In recent years this has declined, and during 1914-1918 has been 9 per cent. Merely a trace of tobacco production has existed in the Mountain and Pacific States.

The North gained relatively in tobacco production from 1839 to 1879, and rose from 8 to 28 per cent of the total, and thereafter the relative gain was transferred to the South, where it reached 77 per cent of the whole crop in 1914-1918.

Virginia led in tobacco production in 1839, with 34 per cent, or more than one-third, of the national total. The Civil War placed Kentucky in the lead, and by 1869 that State produced 40 per cent of the whole crop. This lead has been held to the present time, the average for 1914-1918 being 35 per cent. By 1899, Virginia had fallen behind North Carolina also, when the latter State produced 15 per

cent of the total crop, but North Carolina did not continuously hold second place until in more recent years. In the five years, 1914-1918, North Carolina's fraction was 18 per cent and Virginia's 11 per cent, which placed the latter State third in order. During the same time, Ohio held fourth place, with 8 per cent, and, in order, followed Pennsylvania with 4.5 per cent, Wisconsin with 4.4 per cent, South Carolina with 3.5 per cent, and Connecticut with 3 per cent.

#### PER CAPITA PRODUCTION INCREASING.

Tobacco production per capita apparently declined from 11.1 pounds in the period 1839-1844 to 7.4 pounds in the decade following the Civil War. The information is not as dependable as is desired, but at least the indication was a declining ratio to population. The tendency of the ratio was reversed after 1865-1874, and by 1895-1904 the ratio was 9.3 pounds, followed by 10 pounds in 1905-1914. The yearly ratios of 1915-1919 ranged from 10.6 to 13.7 pounds. Whether this increased per capita production is due to increased acreage more than to increased yield per acre will be examined later.

#### PRICE PER POUND TO GROWERS.

Little information is at hand concerning the price of tobacco to growers before 1863. In the money of the time the Jamestown tobacco sent to England in 1618-20 had a price of  $54\frac{3}{4}$  cents per pound, but by 1639 the price had fallen to 6.08 cents and by 1664 to 3.09 cents. A price of 1.52 cents is recorded for the Virginia and Maryland crop of 1730, of 4.2 cents for that of 1735, and from 2.3 to 4.56 cents thereafter for the colonial crops of various years to 1790. The producers' average selling price of the tobacco of 1847 has been estimated to have been 5 cents per pound; of 1849, 7 cents; and of 1853, 10 cents per pound.

The annual estimates of the producers' average price of tobacco by the Bureau of Crop Estimates began in 1863 with 14.8 cents per pound in gold. In the decade 1865-74 the average was 9.5 cents, and low-water mark since the Civil War was reached in 1895-1904, when the average was 7 cents. In one year—1896—the price was as low as 6 cents.

Thereafter the upward movement of prices brought tobacco to 10.1 cents per pound in 1905-14, 14.7 cents in 1916, 24 cents in 1917, 28 cents in 1918, and 39 cents in 1919. The gain in price since 1896 may not have been entirely due to the diminishing purchasing power of the dollar. There was increased cost of production, and producers have been stronger financially and more able to hold for a higher price. Moreover, the postwar demand has been unprecedented.

#### VALUE OF CROP.

While the value of the tobacco crop is of great importance locally, it has become a matter of some consequence also as an item in the national total of all crops. Its fraction of the total is small because of the towering magnitude of corn, cotton, wheat, hay, and oats, yet the tobacco crop is exceeded in value to the producer by only six crops, and in 1919 its value was equal to the combined value of apples, cranberries, oranges, peaches, cowpeas, hops, soy beans, broom corn, and maple sugar and sirup; it almost equaled the value of the potato crop; it was more than two and one-half times the value of the barley crop; and its value was greater than the combined values of buckwheat, the kafirs, rice, rye, flaxseed, and sugar beets.

To the great value of \$402,000,000 for the tobacco crop of 1918, and \$543,000,000 for that of 1919, the crop has increased from the \$10,950 of the Jamestown crop of 1618. It is computed that the crop of 1664 was worth \$734,000 to the colonists; \$1,030,000 was reached in 1684, and \$1,114,000 in 1698. By 1762 the value had become \$4,413,000, and this seems to have been about the limit until 1790, when the estimate is \$4,420,000. The amount had become \$11,000,000 by 1847, \$19,900,000 by 1853, \$37,000,000 by 1866, and \$106,000,000 was reached in 1909.

#### VALUE PER ACRE.

Per acre of production, the gross value of the tobacco crop to producers declined from \$68.24 in 1865-1874 to \$53.78 in 1895-1904. Then followed rapid rise to \$83.60 in 1905-1914, and \$120.05 in 1916, \$197.92 in 1917, \$243.62 in 1918, and \$285.37 in 1919. This is a crop that requires much attention and labor, from the time when seed is sown in frames

or other favorable place to obtain plants for resetting, to the ultimate stripping of leaves from stalks and packing for sale, and the amount of gross income per acre may not be fairly comparable with that of such a crop, for instance, as wheat.

#### TOBACCO AS A WORLD CROP.

While it is not possible to ascertain how much tobacco is produced in the entire world, it is possible to do so for many countries and thus account for most of the world's production. For countries for which estimates were available, the total of 1900 was 2,201,000,000 pounds. The world crop touched 2,834,000,000 pounds in 1910 and fell to 2,254,000,000 pounds in 1914 and 2,153,000,000 pounds in 1915.

About one-half of the world's tobacco crop, as nearly as it can be ascertained, was produced by the United States in 1915. The fraction previous to 1909 was hardly one-third back to 1900, before which year the world's crop has not been compiled. European Russia (proper) was next although far below the United States in production from 1900 to the beginning of the World War, with a fraction of about 6 to 10 per cent of the world's total. Third in order below was Austria-Hungary, whose fraction was 5 to 8 per cent. The fraction of the Dutch East Indies, the source of the Sumatra leaf, varied from about 3 to 8 per cent; the place of the Japanese Empire is indicated by about 3 to 7 per cent; Germany's by about 2.5 to 4 per cent; Brazil's by 1.5 to 4 per cent; and that of Mexico and of Asiatic Russia each by 1 to 2 per cent.

Under the dominion of the United States, the Philippine Islands advanced from a previous fraction of 1.5 to 2 per cent to as much as 4.7 per cent of the world's production. From these islands comes the so-called Manila tobacco. Porto Rico's fraction has been from about one-fifth to one-half of 1 per cent. In 1915, the United States and its possessions produced more than one-half, or nearly 54 per cent, of the world's crop of tobacco, and in 1914 and 1913 about an even one-half.

#### AREA DEVOTED TO TOBACCO.

Since the estimate of 216,400 harvested acres of tobacco in the United States made by the Bureau of Crop Estimates

for 1863, the area has irregularly increased to 1,647,100 acres in 1918, and 1,901,200 acres in 1919, with intermediate census acreages from 1879 to 1909.

Tobacco is one of the "principal" crops and is rated as one of considerable importance from a national point of view, and of high importance within the limits of some of the States, and yet the area occupied by it is a very insignificant fraction of farm and of crop area. The census for 1909 found 1,294,911 acres devoted to tobacco, and this area was 0.41 per cent of the total crop area, and 0.15 per cent of the farm area.

#### YIELD PER ACRE.

Fundamental to agriculture is the yield per acre. In the case of tobacco, 10-year averages have been adopted, when possible, to smooth out yearly variations. During 1865-1874, the national average yield per acre was 722.3 pounds, and it fell to 719.9 pounds in the following 10 years, and to 714.4 pounds in 1885-1894. Thereafter the gain has been marked, and the average of 768.8 pounds during 1895-1904 was followed by 827.5 pounds during 1905-1914. During 1915-1919, the yearly yield ranged from 730.8 to 873.7 pounds.

To discover whether this apparent gain in yield per acre, which began with the decade of 1895-1904, is not an arithmetical fiction due to a redistribution of the crop geographically, it has been analyzed by States, with the result that gain has been found in all of the prominent tobacco States for periods covering the last 20 to 40 years. In the last 10 years the average yield per acre in these several States has gained upon a former decade with the lowest average, at the end of a decline, by 12 to 40 per cent. The gain in Kentucky is 22 per cent in 40 years, in North Carolina 40 per cent in 30 years, in Virginia 19 per cent in 30 years, in Ohio 16 per cent in 20 years, in Pennsylvania 20 per cent in 20 years, and in Wisconsin 24 per cent in 40 years. These increases, as well as the increase for the national total, must express the results of an improved agriculture.

More fundamental than the tendency of yield per acre is that of the ratio between this yield and population. Answer is wanted to the question, "Is the productivity of the soil gaining as fast as population?" The significance



of the answer is modified by a changing percentage of the population who use tobacco, but nothing is known concerning this modification. The average yield of tobacco per acre per 1,000,000 of the population was 18.5 pounds in the decade 1865-1874; it fell to 14.4 pounds in the next decade, to 11.5 pounds in 1885-1894, to 10.1 pounds in 1895-1904, and to 9.1 pounds in 1905-1914, and the yearly averages for 1915-1919 range from 6.9 to 8.3 pounds.

The inference is plain that apart from the unknown fraction of the population that has used tobacco from year to year the yield of the soil in tobacco has declined for half a century in its ratio to population. In connection with this declining ratio, it is observed that during the period covered, a half century, the per capita production per acre declined 57 per cent, while the population increased 139 per cent. It follows that if the number of users of tobacco did not increase as much relatively as the population did the production per acre per capita of tobacco users may have declined less than is computed for the entire population, if it declined at all. Concerning this, however, there is no information.

#### EXPORTS OF DOMESTIC TOBACCO.

Tobacco was the first export of the colonies. Jamestown sent 20,000 pounds of it to England in 1618, and the exports grew to 500,000 pounds in 1627. The quantity sent to England from Virginia and other colonies increased irregularly until, for a few years before the Revolution, it was about 100,000,000 pounds a year. Not until the fiscal year beginning in 1835 was this mark permanently reached; the 200,000,000-pound mark was permanently reached in 1870, the 300,000,000-pound mark in 1899, and the 400,000,000-pound mark in 1912. The weight of manufactured tobacco is included. The highest export was over 684,000,000 pounds in the fiscal year beginning in 1918, partly to supply deficiency in stocks in Europe caused by the war.

The average export value of the exports of unmanufactured tobacco advanced to \$21,000,000 in 1858, and this amount was not permanently passed until 1884. The average of 1895-1904 was nearly \$28,000,000 and of 1905-1914 it was nearly \$40,000,000. During the war years the value advanced from \$44,000,000 in 1914 to \$190,000,000 in 1918.

## EXPORTED MANUFACTURED TOBACCO.

After the Revolution small quantities of manufactured tobacco were exported, and the quantity increased relative to total tobacco exports, as well as absolutely, until by 1859 it was 9.3 per cent of all tobacco exports. In 1868 manufactured tobacco almost entirely disappeared from exports and did not return appreciably until 1897, since which year to 1915 the quantity has been about 3 to 4 per cent of the total tobacco exports. The fraction was 6.2 per cent in 1916, 11 per cent in 1917, and 8 per cent in 1918 for the fiscal years beginning with July.

## EXPORTS DECLINING RELATIVE TO POPULATION AND PRODUCTION.

Tobacco exports per capita have persistently declined since 1790. From that year to 1794 the average exports of domestic tobacco were 19.7 pounds per capita, and by 1845-1854 the average had fallen to 6.1 pounds. During 1875-1884 it was 4.9 pounds, and by 1905-1914 it had become 4.1 pounds. From 1915 to 1918 it varied from 3.1 to 6.5 pounds.

The exported fraction of the crop, too, has been a diminishing one. For 1790 the fraction was 78 per cent; for 1845-1854, 67.2 per cent; for 1875-1884, 53.9 per cent, from which the decline was steady to 40.6 per cent in 1905-1914. The percentage was 43 for 1915, 38.1 for 1916, 26 for 1917, and 47.5 for 1918, no allowance being made for the carry-over.

## CHIEF COUNTRIES TO WHICH TOBACCO IS EXPORTED.

In prewar years, the United Kingdom received more than one-third of the tobacco exported from this country, and about one-tenth went each to France, Germany, and Italy. Over 6 per cent went to the Netherlands, 5 per cent to Spain, 4 per cent each to Australia and Canada, 3 per cent to Belgium, and 2 per cent to China. Of course, the war very much disturbed these percentages.

## PRINCIPAL EXPORT COUNTRIES.

The average yearly exports of tobacco in the world's trade grew from 755,000,000 pounds in 1904-1908 to 924,000,000 pounds in 1909-1913, of which latter quantity the share of the United States was over 41 per cent. In the latter period, the Sumatra leaf of the Dutch East Indies

supplied 18 per cent of the world's tobacco exports; 6.5 per cent went from Brazil, 5 per cent from Turkey, 4 per cent from Cuba, 3 per cent each from British India and the Philippine Islands, and 2.5 per cent each from Algeria, Russia, and Santo Domingo.

#### TOBACCO IMPORTS.

Tobacco varies greatly in its characteristics as they appear to smokers, and fancy, perhaps created by habit, gives preference to one or another of the many varieties and sub-varieties of the plant produced throughout the world. For this reason, the United States, the greatest tobacco producing and greatest tobacco exporting country in the world, also imports tobacco enough to make it the sixth in order among the tobacco importing countries of the world.

There is a record of the import of 5,481 pounds of tobacco into this country in 1789. For many years thereafter small quantities of tobacco were imported yearly, until over 1,000,000 pounds were received in 1838. By 1858, the imports had grown to 15,000,000 pounds, a quantity that was not subsequently equaled until 1882. In the few years preceding the World War, the tobacco imports had become about 50,000,000 pounds, and during the war the quantity rapidly expanded to 64,000,000 pounds in 1915, 76,000,000 pounds in 1916, and again in 1917, followed by 73,000,000 pounds in 1918. Shipments of tobacco to contiguous United States from the Philippine Islands are included in the total imports of tobacco for all years, when they existed, and shipments from Porto Rico before 1900 and for 1914 and later years.

#### NOW MAINLY UNMANUFACTURED.

For many years the imported tobacco was mostly if not entirely in manufactured form, but by 1846, when the first record of imports of unmanufactured tobacco was published, about one-half of the imports were manufactures. The Civil War reduced the fraction to one-fifth and attendant legislation to one-eighth. In the 10 years 1875-1884, the fraction was 8.7 per cent for manufactured tobacco; in 1885-1894, 6.2 per cent; in 1895-1904, 3.7 per cent; and in 1905-1914, 4.8 per cent. The yearly percentage increased from 6.0 to 9.3 from 1915 to 1916, and remained at the latter figure in the following two years.

## IMPORTS AN INCREASING BUT SMALL FRACTION OF PRODUCTION.

As a fraction of this country's crop, the imports of tobacco never exceeded 5 per cent until 1906, when they were 5.4 per cent, and never exceeded 6 per cent, except in 1915, when they were barely more, except in 1916, when they were 6.6 per cent, and except in 1917, 6.1 per cent.

By 10-year periods, tobacco imports were equal to 2.2 per cent of the crop in 1865-1874, followed by irregular increase to 3.2 per cent in 1895-1904 and to 4.9 per cent in 1905-1914.

## TOBACCO IMPORTS IN THE WORLD'S TRADE.

The fragrant leaf of Cuba is by far the chief tobacco imported into the United States. Before the recent war it was 45 per cent of the total tobacco imports, but the fraction greatly declined during the war and in the year beginning with July, 1917, it was only 19 per cent. In prewar times, 12 per cent of this country's tobacco imports came from Turkey in Asia and 10 per cent from Turkey in Europe, or 22 per cent from that Empire. The war extinguished the direct trade movement, but apparently tobacco imports from Greece, which were normally little more than 1 per cent, took up this movement, with the result that tobacco imports from that country grew to 17 per cent of the total in 1917.

Next in order below was Sumatra's thin leaf, with 11 per cent of the total tobacco imports into the United States before the war, or at any rate this was the fraction for the tobacco received from the Netherlands. So-called Egyptian tobacco, that is, tobacco consigned from Egypt, made a mere trace in the tobacco imports into this country, both normally and during the war. Porto Rican and Philippine tobacco will be mentioned under trade with these possessions.

Before disturbance of the world's trade by the war the world's tobacco imports, which were mostly ascertainable, increased from the yearly average of 717,000,000 pounds in 1904-1908 to 844,000,000 pounds in 1909-1913. Germany was the chief tobacco importer among the nations, and received 22 per cent of the world's total in the former period and 20 per cent in the latter. The United Kingdom received 12 and 14 per cent, respectively, in the two periods; France, 9 and 8 per cent; Austria-Hungary, 7 and 6 per

cent; the Netherlands, 7 per cent in both periods; Spain, 6 per cent in both periods; Italy, 5 and 6 per cent; the United States, 5 and 6 per cent; Belgium, 3 per cent in both periods; Egypt, 3 and 2 per cent; Canada, China, and Switzerland, each 2 per cent in both periods; Denmark, 2 and 1 per cent; Argentina and Australia, each 1 and 2 per cent; and Aden, British India, Finland, Portugal, Southern Nigeria, and Sweden, each 1 per cent in both periods.

#### NATIONAL NET SURPLUS OF TOBACCO.

It has already been made apparent that the United States has always been a surplus country as a net result of the inward and outward movements of tobacco in foreign trade. From the small beginning at Jamestown, the national tobacco surplus grew to be 36,000,000 pounds in 100 years, 80,000,000 pounds in 200 years, and 326,000,000 pounds in 300 years, or rather in the normal years before the World War. Most of this tobacco has been unmanufactured. With regard to manufactured tobacco, in some years the United States has received more than it exported, but beginning with 1892 the exports have predominated in every year, and the yearly average net surplus for 1905-1914 is 11,000,000 pounds, or 3 per cent of the net surplus of all tobacco.

The national net surplus of tobacco, as a fraction of the production, persistently declined from the Civil War to the present time, the decline being from 74 per cent in 1865-1874 to 36 per cent in 1905-1914, and 34 per cent for the four years 1915-1918. Otherwise stated, under normal foreign trade, the tobacco crop could be reduced to a little less than two-thirds of its recent proportions and still provide enough for the national consumption, but this would be in abstract pounds instead of concrete varieties of tobacco actually in demand.

#### PHILIPPINE ISLANDS AND PORTO RICO.

Interchange of tobacco between contiguous United States and the Philippine Islands was weak until 1909, when the tobacco imports from that possession, mostly manufactured, suddenly rose to 1,200,000 pounds. This was about the average until 1916, when the imports reached 5,100,000 pounds, followed by 11,700,000 pounds in 1917, and 8,700,000

pounds in 1918, the unmanufactured tobacco being about one-half of the total in the last year.

There has also been a considerable movement of tobacco from the United States to the Philippine Islands, beginning in 1909. Before that year, and in 1914 and 1915, the exports exceeded the imports; but from 1909 to 1913 the average yearly excess of imports was 641,000 pounds, in 1916 it was 4,100,000 pounds, in 1917 it was 10,900,000 pounds, and in 1918 it was 7,500,000 pounds, or about 1 per cent of the national consumption.

Shipments of tobacco from Porto Rico to the United States have been much larger than those from the Philippines. The yearly average for 1904-1913 was 6,300,000 pounds, three-quarters of which was unmanufactured. The quantity grew to 19,300,000 pounds in 1917, and was 17,500,000 pounds in 1918.

On the other side of the account, shipments of tobacco from the United States to Porto Rico averaged 1,500,000 pounds yearly during 1904-1913, and reached 2,000,000 pounds in 1917. After subtracting the tobacco shipments from the United States to Porto Rico from those to the United States from Porto Rico, the net receipts by this country averaged 4,700,000 pounds yearly from 1904 to 1913, and ranged from 8,200,000 to 17,500,000 pounds from 1914 to 1918, or from 1.2 to 2.4 per cent of the national consumption.

In the combined tobacco trade of these two possessions with the United States, the net average annual receipts by this country were 5,100,000 pounds in 1904 to 1913, and rapidly rose to 28,100,000 pounds in 1917, followed by 25,000,000 pounds in 1918, or 3.4 per cent of the national consumption.

#### LARGE YEARLY CARRY-OVER OF TOBACCO.

Tobacco has a remarkable commercial feature in its enormous carry-over from one crop year to another. The quarterly report of stocks of leaf tobacco in the hands of dealers and manufacturers, made by the Bureau of the Census, small businesses being excluded, shows that the leaf stocks of chewing, smoking, snuff, and export tobacco are lowest on October 1 and the cigar types on January 1. For all stocks October 1 is the time when they are lowest.

For October 1 the reported stocks of leaf tobacco in the hands of dealers and manufacturers were 1,047,000,000 pounds in 1912, and the quantity increased year by year until in 1919 it equaled 1,264,000,000 pounds, or almost as much as the crop of that year. Of that amount, the stocks of domestic chewing, smoking, snuff, and export types were 892,000,000 pounds, the domestic cigar types, 292,000,000 pounds, the Porto Rican tobacco 11,000,000 pounds, and the imported types 69,000,000 pounds. The quarter when stocks are highest is April 1, and in 1919 there were 1,627,000,000 pounds on that date, or 13 per cent greater than the crop of 1918 and 29 per cent greater than the stocks of October 1, 1918.

*Supply and distribution of leaf tobacco in the United States, 1918.*

[From Bulletin 139, Bureau of the Census. Production of 1918; consumption of calendar year 1917; trade with foreign countries and possessions, calendar year 1918.]

SUPPLY.	
	<i>Pounds.</i>
Total (exclusive of stocks held by small manufacturers and dealers and by growers).....	2,611,288,797
Stocks held at beginning of year—total.....	1,176,234,657
By manufacturers and dealers within the scope of the law.....	1,129,176,763
By small manufacturers and dealers and by growers.....	Unknown.
In United States bonded warehouses.....	47,057,894
Production.....	<sup>1</sup> 1,340,019,000
Imports (gross).....	83,563,850
Shipments from noncontiguous territories.....	11,471,290
Hawaii.....	20,643
Porto Rico.....	11,450,647
DISTRIBUTION.	
Total (exclusive of stocks held by small manufacturers and dealers and by growers).....	2,611,288,797
Exported.....	425,630,104
Domestic.....	406,291,746
Foreign.....	19,338,358
Consumed (during 1917).....	684,913,794
In registered factories.....	658,066,105
In bonded manufacturing warehouses.....	26,847,689
Shipments to Porto Rico.....	1,143,793
Stocks held at end of year—total.....	1,234,884,396
By manufacturers and dealers within the scope of the law.....	1,180,447,727
By small manufacturers and dealers and by growers.....	Unknown.
In United States bonded warehouses.....	54,436,669
To balance supply.....	264,716,710

<sup>1</sup> Subsequently revised by the Bureau of Crop Estimates to 1,439,071,000 pounds.

## ANALYSIS OF CONSUMPTION.

When Europeans established colonies on the Atlantic seaboard of North America, the natives had been using tobacco from time immemorial. From them, the whites learned to smoke it, to chew it, and to use it as snuff. Without mentioning the numerous varieties and subvarieties of preparations of tobacco that are now used, it is sufficient for the present purpose to say that eventually it was used for smoking in the form of cigars, cheroots, cigarettes, and many preparations for the pipe; for chewing as fine cut, plug, and twist; and in finely pulverized condition, as snuff in the nose, or on one end of a small stick of wood in the mouth. Besides these personal uses, it was learned that a decoction of stems or leaves would rid plants of insects and domestic animals of external parasites, if the animals were "dipped" in it, and that the smoke would expel insects from plants.

## GREAT GAIN OF THE CIGARETTE.

Since 1895, the Commissioner of Internal Revenue has ascertained and published the quantities of leaf tobacco used in this country in the manufacture of cigars, cigarettes, and "tobacco and snuff," the last class being chiefly chewing and smoking tobacco. Certain imported tobacco withdrawn from bonded warehouses, mostly in Florida, is not included.

After converting these three classes into percentages of the total leaf tobacco used by manufacturers, it appears that the fraction for cigars increased from 25 per cent in the calendar year 1896 to 30 per cent in 1907, when the advance was arrested. From 1908 to 1914 the percentage ranged from 27 to 29, and a rapid decline followed during the World War to 26.5 per cent in 1915 and 1916 and to 25 per cent in 1918.

More than one-half of the leaf tobacco annually used by manufacturers during this period has become chewing and smoking tobacco and snuff, but the fraction has been a declining one. From about 70 per cent of the total in the earlier years, it fell to 65 by 1911, to 61 per cent by 1915, followed by rapid fall to 52 per cent in 1918.

Necessarily, the third class, cigarettes, must have absorbed the relative losses of the other two when they occurred in the same year. Early in the period under review,



about 5 per cent of all leaf tobacco used by manufacturers was converted into cigarettes, but years of decline followed to 3 per cent in 1905. Thereafter the upward movement was strong. It reached 4 per cent in 1908, 6 per cent in 1910, 10 per cent in 1913, 12 per cent in 1915, 15.5 per cent in 1916, 20 per cent in 1917, and 23.5 per cent in 1918.

The result of these three movements in consumption was that the leaf tobacco used for cigarettes, which was equal to about one-fifth of the leaf tobacco used for cigars in the earlier years of the period, increased to almost the same quantity in 1918. As a ratio to chewing, smoking, and snuff tobacco, cigarette tobacco advanced from about 7 per cent in the earlier years to 46 per cent in 1918.

This period of 23 years began with a leaf consumption which was apportioned five-twentieths to cigars, fourteen-twentieths to chewing and smoking tobacco and snuff, and one-twentieth to cigarettes; in 1918 the apportionment had become nearly five-twentieths each to cigars and cigarettes, and a little more than ten-twentieths to chewing and smoking tobacco and snuff. The figures are based on pounds of tobacco and not on number of units of manufacture. The extraordinary advance of the little cigarette during the war was connected with the mobilization of great military and naval forces.

#### POUNDS OF TOBACCO USED.

Tobacco needs to be cured by the growers after it is harvested and variously aged and treated by the manufacturer afterwards. The processes require much time, and this is considerably lengthened while the finished products are carried by wholesale and retail dealers. As has already been shown, the stocks of leaf tobacco in the hands of manufacturers and leaf dealers are very large relative to the size of the crop, and the carry-over is relatively enormous. Unlike potatoes, for instance, which must be consumed within the crop year, tobacco's ultimate consumption is long delayed. For this reason, the quantity of the ultimate consumption of tobacco in any single year is not known, and, to avoid mostly the one-year error, the average of a group of years should be taken. The formula adopted for this article for determining the quantity of tobacco consumption is: pro-

duction plus or minus the net result of the foreign trade, possessions being treated as foreign countries.

The oldest year for which tobacco consumption is estimated is 1790. Perhaps at that time the objections to the estimate for one year were not as strong as they are now. At any rate, the quantity appears to have been nearly 29,000,000 pounds. For 1839 to 1844, the yearly consumption is reckoned to have been over 60,000,000 pounds, and for five years of the decade 1845-1854 the average stood at over 71,000,000 pounds. In the entire decade 1865-1874, the yearly tobacco consumption had increased to nearly 76,000,000 pounds. Thereafter the increase was more marked. The average consumption of 1875-1884 was 219,000,000 pounds; of 1885-1894, 312,000,000 pounds; of 1895-1904, 401,000,000 pounds; and of 1905-1914, 588,000,000 pounds. The quantity of tobacco available for consumption, according to the process used, increased from 669,000,000 to 790,000,000 pounds from 1915 to 1916, and was 1,000,000,000 pounds in 1917 and 828,000,000 pounds in 1918. The average of the last two years is better for those years than the numbers mentioned, and this is 914,000,000 pounds. Prewar consumption was eight times the consumption of 40 years before, and in the war years apparently 10 times that quantity.

To one who knows that many a cigar sold as "an Havana" contains no Cuban tobacco, but at the best is wholly or partly composed of tobacco grown in the United States from seed of the "Havana" variety, it will be no surprise to know that the foreign tobacco consumed in this country is relatively small. In the five decades before the World War its fraction of the total consumption ranged from about 5 to 8 per cent, and during the war was about 9.5 per cent. The absolute quantity consumed, however, has had a strong upward movement. The average yearly consumption of foreign tobacco rose from 6,000,000 pounds in 1865-1874 to 45,000,000 pounds in 1905-1914, and the computed yearly consumption during the war years was about 72,000,000 pounds.

#### PER CAPITA CONSUMPTION.

Much waste of tobacco attends the smoking of cigars and cigarettes, and an appreciable waste goes with pipe smok-

ing. There is some destruction of tobacco after harvest, relatively small, by weather, fire, and vermin. All together there must be a lost fraction of tobacco that figures as available for consumption that is more than perceptible.

The computed per capita consumption of tobacco in this country has been steadily gaining since 1865-1874. Before that time, back to 1839, it seems to have been about 3.3 pounds. Following the Civil War the computed average is as low as 2 pounds, and this was followed by a climbing movement that reached 6.4 pounds in 1905-1914 and 8 pounds during the following four years. For domestic tobacco the per capita consumption grew from 1.8 pounds in 1865-1874 to 5.9 pounds in 1905-1915 and for foreign tobacco from 0.16 to 0.49 of 1 pound. What was said on a previous page concerning the unknown fraction of the population that does not use tobacco should be recalled.

#### FRACTION OF THE CROP USED.

From 30 to 35 per cent of the tobacco crop was equivalent to the consumption, respectively, of 1839-1844 and 1845-1854, including foreign tobacco. In the decade after the Civil War the fraction was apparently 26 per cent, and from that low figure it has grown steadily to 64 per cent in 1905-1914, and perhaps to 67.3 per cent during the war years 1915-1918. That is to say, consumption is overtaking production and has nearly reached the two-thirds mark. Leaving foreign tobacco out of account, domestic tobacco consumption has become about three-fifths of the crop, whereas it was under one-half 30 years ago.

Relationships exist among several per capita ratios. Regarding recent years as present time it may be said that tobacco production per capita is increasing, because tobacco acreage is increasing faster than population. Production per acre per capita is decreasing; fertility improvement is not keeping up with human multiplication and immigration. The excess of tobacco exports over imports per capita is declining. The resultant of all these movements is an increasing per capita consumption of domestic tobacco that is absorbing a larger and larger fraction of the per capita production.

## HISTORIC COURSE OF IMPORT DUTIES.

Tobacco has been subject to an import duty every year since the present Nation began under the Constitution. The first act relating to this subject was approved July 4, 1789, and took effect August 1. It subjected imported snuff to a duty of 10 cents per pound; unmanufactured tobacco, 6 cents per pound; and manufactured tobacco, 5 per cent ad valorem. To conform to subsequent classifications of tobacco the course of the duty as applicable to each class is given below from the first act to 1919.

The duty on unstemmed wrapper tobacco, which began at 6 cents per pound August 1, 1789, was changed to 7½ per cent ad valorem in 1792 and this was increased by steps to 15 per cent in 1804. The War of 1812 caused an increase to 30 per cent in that year, but the rate was reduced to 15 per cent in 1816 and stepped up to 20 per cent in 1841 and 30 per cent in 1846. The rate fell to 24 per cent in 1857, rose to 25 per cent in 1861, was changed to 25 cents per pound in 1862, after which year it was 50 cents per pound for 60 days in 1864, 35 cents later in 1864, 75 cents in 1883, \$2 in 1890, followed by \$1.50 in 1894, and \$1.85 in 1897.

Previous to 1862, rates of duty on stemmed wrapper were the same as on unstemmed. In that year the rate of 35 cents per pound was imposed, followed by 70 cents per pound for 60 days in 1864, 50 cents later in 1864, \$1 in 1883, \$2.75 in 1890, \$2.25 in 1894, and \$2.50 in 1897.

Unstemmed filler tobacco had the same rates as unstemmed wrappers until 1882, after which year the rates remained at 35 cents per pound. Likewise, stemmed filler tobacco bore the rates of stemmed wrappers until 1882. The duty was reduced to 40 cents per pound in 1883, and restored to 50 cents in 1890.

Stems were first mentioned in a tariff act in 1865, when a duty of 15 cents per pound was imposed. Their entry was made free in 1890. Before 1865, if any stems were imported, they bore the rates of "other unmanufactured tobacco."

"Other manufactured tobacco" had the rates of duty on leaf tobacco before 1861, when a duty of 30 per cent ad valorem was imposed, or 5 per cent higher than the leaf duty. The rate was changed to 60 per cent for 60 days in 1864, to 35 cents per pound later in 1864, to 30 per cent ad valorem

in 1883, to 35 to 50 cents per pound in 1890, to 40 cents in 1894, and to 55 cents in 1897.

Manufactured tobacco was free of duty for two years, from July 1, 1792, to June 30, 1794. With this exception, snuff has always been subject to a duty, 10 cents per pound in 1789, 12 cents in 1794, 24 cents in 1812, 12 cents in 1816, 40 per cent ad valorem in 1846, 30 per cent in 1857, 10 cents per pound in 1861, 35 cents in 1862, 70 cents for 60 days in 1864, 50 cents later in 1864, and 55 cents in 1897.

Beginning with a duty of 5 per cent ad valorem in 1789, cigars, cigarettes, and cheroots were free for two years from 1792 to 1794. In the latter year, the rate was made 4 cents per pound; in 1804, \$2 per 1,000; in 1812, \$4 per 1,000; in 1816, \$2.50 per 1,000; in 1842, 40 cents per pound; in 1846, 40 per cent ad valorem; in 1857, 30 per cent; and in every year, beginning with 1861, there has been a combination of specific and value duties, the details of which are sometimes too many to be repeated. The duties of 1861 ranged from 20 cents per pound for the cheapest cigars, cigarettes, and cheroots, to 60 cents per pound plus 10 per cent ad valorem on the costliest; those of 1862, from 35 cents per pound to \$1 per pound plus 10 per cent ad valorem; for 60 days in 1864, from 70 cents per pound to \$2 per pound plus 20 per cent ad valorem; and, later in 1864, the duties were made from 75 cents per pound plus 20 per cent ad valorem to \$3 per pound plus 60 per cent ad valorem. In 1866, a more simple rate was adopted, \$3 per pound plus 50 per cent ad valorem, followed by \$2.50 per pound plus 25 per cent ad valorem in 1883, \$4.50 per pound plus 25 per cent ad valorem in 1890, \$4 per pound plus 25 per cent ad valorem in 1894, and \$4.50 per pound plus 25 per cent ad valorem in 1897.

Scrap tobacco, first mentioned in the tariff act of 1909, was made to bear a duty of 55 cents per pound, and this was reduced to 35 cents in 1913.

“Other manufactured tobacco,” except for the free period of two years from 1792 to 1794, has always been subject to a duty. The rate of 1789 was 5 per cent ad valorem; of 1794, 4 cents per pound; of 1812, 8 cents per pound; of 1816, 10 cents per pound; of 1846, 40 per cent ad valorem; and of 1857, 30 per cent. A change to 35 cents per pound was

adopted in 1862, to 70 cents for 60 days in 1864, to 50 cents later in 1864, to 40 cents in 1883, and to 55 cents in 1897.

#### INTERNAL REVENUE RATES.

The needs of the Government for revenue led to the first internal revenue act, in force July 1, 1862. There were taxes on tobacco products and on the businesses of tobacco manufacturing and dealing. On each 1,000 cigars made, the tax was \$1.50 to \$3.50. Rates of \$8 to \$40 per 1,000 were provided in 1864; \$10 in 1865; \$2 per 1,000 to \$4 per 1,000 plus 20 per cent ad valorem in 1866; 18 cents per pound to \$3 per 1,000 in 1902; 75 cents per pound to \$3 per 1,000 in 1909; and \$1.50 per pound to \$15 per 1,000 in 1919, war expenses being the cause of these high rates.

The cigarette tax of 1864 was \$1 per 100 packages of 25 or less cigarettes each; of 1865, 5 cents per package of 25; of 1866, \$2 per 1,000 to \$4 per 1,000 plus 20 per cent ad valorem; of 1902, 18 cents per pound to \$3 per 1,000; of 1909, \$1.20 to \$3.60 per 1,000; and of 1919, \$3 to \$7.20 per 1,000.

On cheroots, the tax was \$3 per 1,000 in 1864, or much less than on the same number of cigars, but in 1865 they were made to pay the cigar tax of \$10 per 1,000, and in 1866 and subsequently the cigar tax applied, made elastic so as to fit different weights per 1,000 and different values.

Under the first Internal Revenue Act, snuff paid a tax of 20 cents per pound; in 1864, the rate went up to 35 cents; in 1865 to 40 cents; down to 32 cents in 1868, and to 6 cents in 1902, after which rate followed 8 cents in 1909, and 18 cents in 1919.

The law distinguished between "manufactured" and "smoking" tobacco before 1902, and placed on manufactured tobacco a tax of 10 to 15 cents per pound in 1862, changed to 15 cents in 1863, to 35 cents in 1864, to 35 to 40 cents in 1865, and to 30 to 40 cents in 1866. The tax fell to 32 cents per pound in 1868, and to 6 cents in 1902, after which rate the tax rose to 8 cents in 1909 and 18 cents in 1919.

In the case of smoking tobacco, the original tax of 2 to 5 cents per pound in 1862 was followed by 5 cents in 1863, 15 to 25 cents in 1864, 35 cents in 1865, 15 to 40 cents in

1866, and 16 cents in 1868, after which rate the tax on manufactured tobacco applied in 1902 and subsequently. The smoking tobacco taxes applied to tobacco scraps in 1868 and later.

Occupation taxes were placed on tobacco manufacturers and wholesale and retail dealers by the act in force July 1, 1862. The details of some of the rates are too elaborate for restatement, but, in brief, it may be said that the simple tax of \$10 a year on tobacco manufacturers beginning with July 1, 1862, was somewhat elaborated and increased a few years later, and the tax was eventually abandoned. The expenses on account of the World War, however, compelled a return to this tax in 1919, with the provisions that the yearly tax on the business of manufacturing "tobacco" should be \$6 to \$24 plus 16 cents per 1,000 pounds of tobacco used above 200,000 pounds; of manufacturing cigars, \$4 to \$24 plus 10 cents per 1,000 cigars made above 400,000 cigars; of manufacturing cigarettes, 6 cents per 10,000 made.

Tobacco dealers, too, originally paid occupation taxes, wholesalers \$50 a year and retailers \$10. Soon there was elaboration of the tax, increase or perhaps decrease for small dealers, the inclusion of leaf dealers, and in 1902 an abandonment of the tax.

#### INCOME OF THE GOVERNMENT FROM TOBACCO.

The rates of duty and the internal tax rates on tobacco have produced in their operations a large amount of income for the Government, and now much more than formerly. To go back no farther than the fiscal year 1866, it may be noted that the customs collections for that year were nearly \$5,000,000; the \$10,000,000 milestone was reached in 1889, and the \$20,000,000 milestone in 1903. Since that year the highest customs collections on account of tobacco were nearly \$30,000,000 in 1917, but the amount fell to \$22,000,000 in 1918. If these amounts of customs seem small it may be remembered that this country has always had a tobacco surplus, and that the imports of tobacco are naturally confined to specialties not here produced.

The internal revenue has always been much larger than the customs receipts from tobacco. In the first year's operation of the law, 1863, the income was \$3,000,000, in the next

year \$9,000,000, and the amount increased to \$31,000,000 by 1870, \$41,000,000 by 1877, and \$47,000,000 by 1882. After that year, the amount declined and remained relatively low until 1898, with a low water mark of \$26,000,000 in 1884. Suddenly, in 1899, the income jumped to \$52,000,000 and the amount reached \$71,000,000 in 1912, \$85,000,000 in 1916, \$102,000,000 in 1917, and \$156,000,000 in 1918.

These two sources of revenue for the Government together produced \$13,000,000 in 1865, \$52,000,000 in 1897, \$75,000,000 in 1909, \$104,000,000 in 1913, \$132,000,000 in 1917, and \$178,000,000 in 1918.

As a fraction of the total ordinary receipts of the Government, the customs income from tobacco has always been small. It did not continuously equal or exceed 2 per cent of the total receipts until 1884, and, generally speaking, its position was between 3 and 4 per cent of the total after 1898 and until 1916. The great war income reduced the fraction to 0.5 per cent in 1918.

The fraction of the total ordinary receipts derived from the internal tax on tobacco reached 11 per cent by 1873 and 16 per cent by 1878, after which year there was a period of recession until 1898, when there was restoration to 10 per cent, but not until 1915 was 11 per cent reached. The fraction was 9 per cent in 1917, and 4 per cent in 1918.

The time when customs and internal income from tobacco together were the largest fraction of the total ordinary receipts of the Government was in the 70's of the last century, and the highest fraction, 17.4 per cent, is found in 1878. Since 1879, the fraction has in general ranged from about 10 to 14 per cent until 1912, followed by increase to about 15 per cent in 1915, and rapid drop from 1916 to 4 per cent in 1918, notwithstanding the great increase in the amount of the income from tobacco.

#### MAGNITUDE OF THE TOBACCO-MANUFACTURING INDUSTRY.

By the time that this country had recovered from the industrial depression of 1893-1897, the production and consumption of tobacco products had become fairly normal. The Commissioner of Internal Revenue reports that the average yearly number of large cigars made in 1899-1901



was about 5,500,000,000 and that the number had increased to the yearly average of 7,200,000,000 for 1916-1918, or 30 per cent. Corresponding figures for small cigars, including cheroots, are 669,500,000 made in the average of 1899-1901 and 900,100,000 in the average of 1916-1918, an increase of 35 per cent. Exports of cigars and cheroots reached the number of about 2,400,000 in the year ending with June, 1917, 15,000,000 in 1918, and 33,100,000 in 1919.

Large cigarettes are not made in any great numbers, relatively speaking, and the average product of 1899-1901 was 4,100,000, while that of 1916-1918 was 23,500,000, or 469 per cent greater.

The most outstanding fact in the tobacco industry is the production of small cigarettes. The average number made in 1899-1901 was 3,200,000,000, and a number that reaches a billion seems large, but in 1916-1918 the average production of small cigarettes was 32,800,000,000, a gain of 913 per cent in 17 years. In 1918 the number rose to 37,900,000,000. It is true that billions of these cigarettes were exported in the war years, the number for the year ending with June, 1917, being about 6,500,000,000; for 1918, about 9,100,000,000; and for 1919, about 13,600,000,000. Still the number remaining for domestic consumption averaged about 23,100,000,000 in the three years, and the consumption by the military and naval forces of the United States, wherever situated, is almost entirely treated as "domestic."

In weight of product, smoking tobacco by far leads every other product. For 1899-1901, the average was 105,400,000 pounds, and in 1916-1917 the quantity had grown to 241,700,000 pounds, a gain of 129 per cent. Plug tobacco is next in weight below smoking tobacco, and averaged 170,700,000 pounds in 1899-1901 and 172,500,000 pounds in 1916-1917, only a little more than in the earlier years. Before 1917, cigars exceeded cigarettes in quantity of leaf tobacco used in their manufacture, and the excess was great until the World War was well advanced. In 1917, cigarettes passed cigars in this respect, and held the lead in 1918.

In quantity of product, snuff now follows below cigars. The average production of 15,300,000 pounds of snuff in 1899-1901 grew to 34,900,000 pounds as the average of 1916-1918, a gain of 127 per cent, a conspicuous fact for such a

product. It is not exported. Tobacco twist has been a farm product from early times, and as a factory product it has increased to an average of 15,600,000 pounds for 1916-17. Fine cut tobacco, used mostly for chewing, has long been about stationary in quantity of product, with a yearly range from about 10,000,000 to 12,000,000 pounds.

In making brief references to the proportions and growth of the tobacco manufacturing industry, it may be mentioned that during the 15 years from the census for 1899 to that for 1914, the capital of this industry increased from about \$112,000,000 to \$304,000,000, or 172 per cent, establishments with products for the year valued at less than \$500 being excluded. The average number of wage earners increased from 133,000 to 179,000, or 35 per cent; the wages paid during the year from \$48,000,000 to \$78,000,000, or 62 per cent; and the gross value of products from \$264,000,000 to \$490,000,000, or 86 per cent.

Main body of text, consisting of several paragraphs of faint, illegible text. The text appears to be a formal document or report, but the specific content is unreadable due to the low contrast and blurriness of the scan.

# THE OPEN ROAD THROUGH THE NATIONS FOREST



By JOHN L. COBBS, Jr.,  
*Forest Service.*

THE old frontier has gone, never to return. Over west-bound trails, where once the sweating mule teams of the emigrants plodded slowly along, high-powered touring cars now poke their fastidious noses; over high mountain passes that the weary pack mules of hardy trapper or prospector climbed with such difficulty, the ubiquitous "flivver" chugs cheerfully across the range. The last frontier is no more. The bad men of the cow towns and mining camps have doffed their "chaps" and donned overalls. They have put away their six-shooters and carry monkey wrenches instead. No longer does the talk concern mavericks and steers and roundups and outlaw horses, but rather spark plugs, cut-outs, cylinder oil, and gas.

In the National Forests, which include much of the wildest mountain country of the West where the last frontier made its final stand, good roads are on the way, where they have not actually arrived, and their coming will make life easier for thousands of people in the little, isolated settlements which have heretofore been cut off from communication with the outside world.

Travel has always been slow and tedious in those mountains. When the Forest Service took over the administration of the National Forests in 1905 the biggest handicap with which it had to contend was the difficulty of getting around in the great areas that had been placed in its care. Many of the Forest boundaries extended down to the open country of the foothills; at places the settlements followed arable valleys back into the mountains. A few long-traveled roads picked their tortuous way through low passes across the ranges; occasional trails, blazed by stockmen or prospectors, led back to high range camps or lonely mining claims. Large sections of the Forest country had not been mapped, and much of it had been explored only by wandering trappers or prospectors, who had followed well-worn game trails, and left only an occasional blaze to mark the way they had gone. Except in the more sparsely timbered country, all travel off the well-beaten ways was by foot or saddle horse, and communication between outlying settlements was slow and uncertain.

As a result of this difficulty of travel the whole work of the Forest Service was retarded. Because there were no roads or trails over which men and supplies could be transported to fight them, Forest fires often burned unopposed for days, or even weeks, and destroyed millions of feet of timber. Administration of the Forests was rendered difficult because the rangers and other forest officers often had to travel long distances over roundabout routes to attend to trivial routine matters. The high cost of packing supplies to crews at work in remote places on the Forests ate heavily into the available money, and the slowness and uncertainty of travel and communication were a never-ending cause of delay and annoyance.

It required no master mind to decide that the opening up of ways of travel and communication was the prime essential for a successful, businesslike administration of the Forests. Construction of trails was one of the first activities inaugurated, and even with the limited funds available for the work, each year saw new projects gradually built up along important valleys and across high mountains into places that had never been trod by shod horse before.

It was soon realized, however, that trails are a makeshift which will serve only so long as the volume of traffic is relatively light. With the growth of business on the Forests, the rapid settlement of the agricultural lands within and adjacent to them, the desire of the settlers for better living conditions, and the advent of the automobile there arose an insistent demand for roads to serve the needs of the Forests and of the nearby communities alike.

The plight of many of these little communities is far from enviable. Land hunger, the search for precious metals, the ever-present urge to push on into new country have led adventurous men and women to settle down in many an out-of-the-way place where they found the thing they sought. Content at first to put up with the inconvenience which their isolation forced upon them, these hardy pioneers and their descendants, as time has passed, have come to want the advantages which the outside world enjoys. They are no longer satisfied to

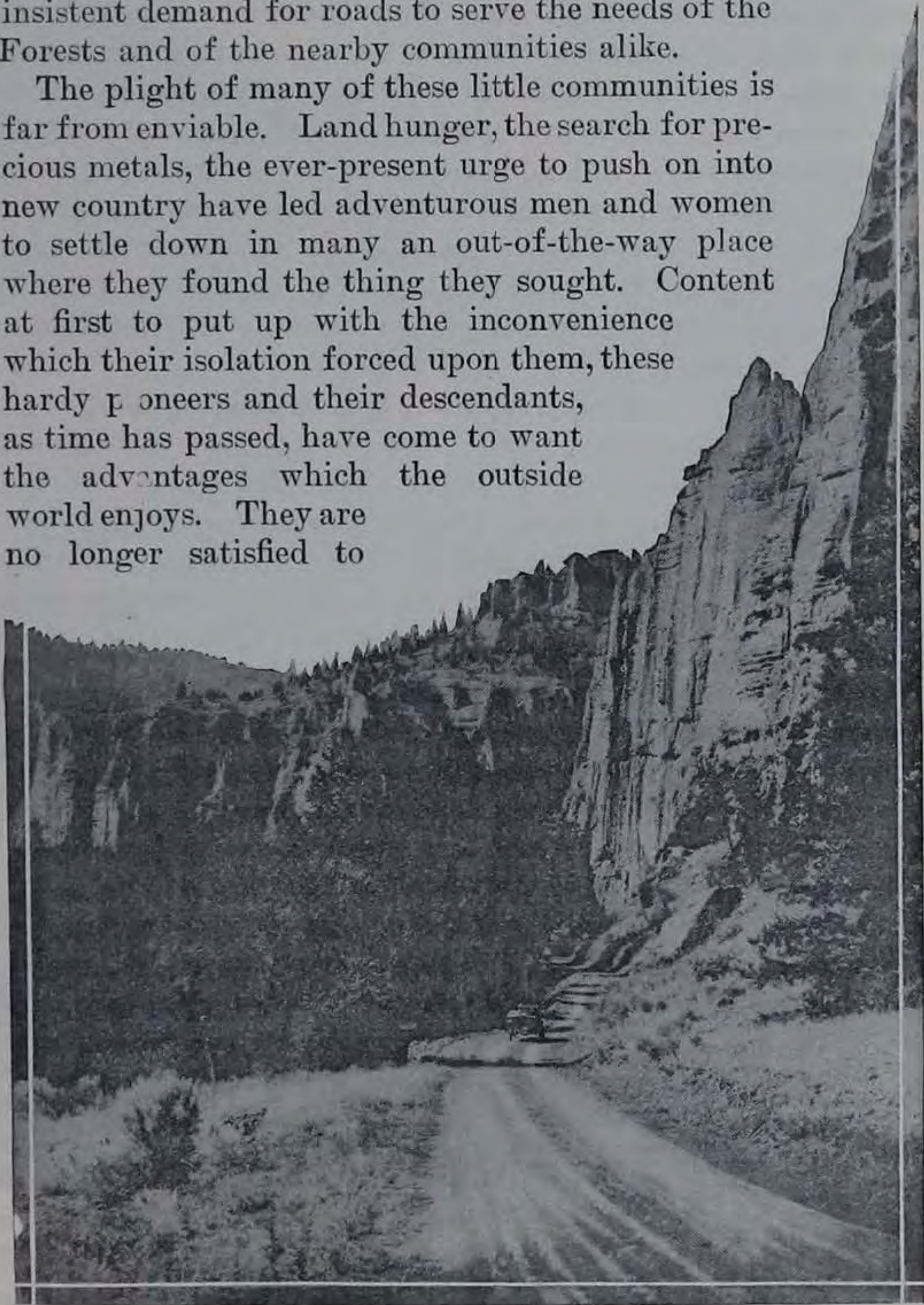

The Cody Road in the Shoshone National Forest, Wyoming.

live under primitive conditions. Roads over which to market the products of their farms and their mines are the first essential—roads of any sort, to begin with, but better and better roads to meet the increasing traffic as time goes on.

Distances, like everything else, are everlastingly big in the West. The cost of even plain dirt roads in easy country is sure to run high, and where construction is difficult, as it usually is, road building is an expensive undertaking. In most cases the counties in which the little, isolated communities are located are sparsely settled and consequently hard up at best; and added to this is the fact that many of them have a large percentage of their area included in National Forests or other reservations on which no taxes can be levied. Not unnaturally, therefore, these counties look to the Government for assistance in the construction of the needed roads.

The justice of their claims was recognized and in order to compensate them for the loss of taxes on Government lands Congress provided that 25 per cent of all receipts from the National Forests should be returned to the counties. As a further help, provision was made that an additional 10 per cent of the receipts should be spent for roads and trails within the Forests, and the funds from these sources proving inadequate to meet the constantly increasing need, \$10,000,000, available at the rate of a million a year, was appropriated by section 8 of the Federal aid road act in 1916. Finally in February, 1919, section 8 of the Post Office act made available \$3,000,000 a year for the fiscal years 1919, 1920, and 1921.

With the money provided for road building there was no trouble in finding worthy projects upon which to spend it. Not only was there need for new roads into undeveloped territory, but also for repairs and relocation of existing roads, many of which had been used since pioneer days. There was so much work to be done that the decision as to which projects should be undertaken was not easy. Each community contended that its needs were paramount. Each advanced supposedly unanswerable reasons why its own project should be built without delay. Certain projects of obviously great importance were selected and considerable construction done from 1913 to 1916.

In the latter year, when the money under section 8 of the Federal aid road act was made available, the necessity of taking a long look ahead to determine the ultimate road

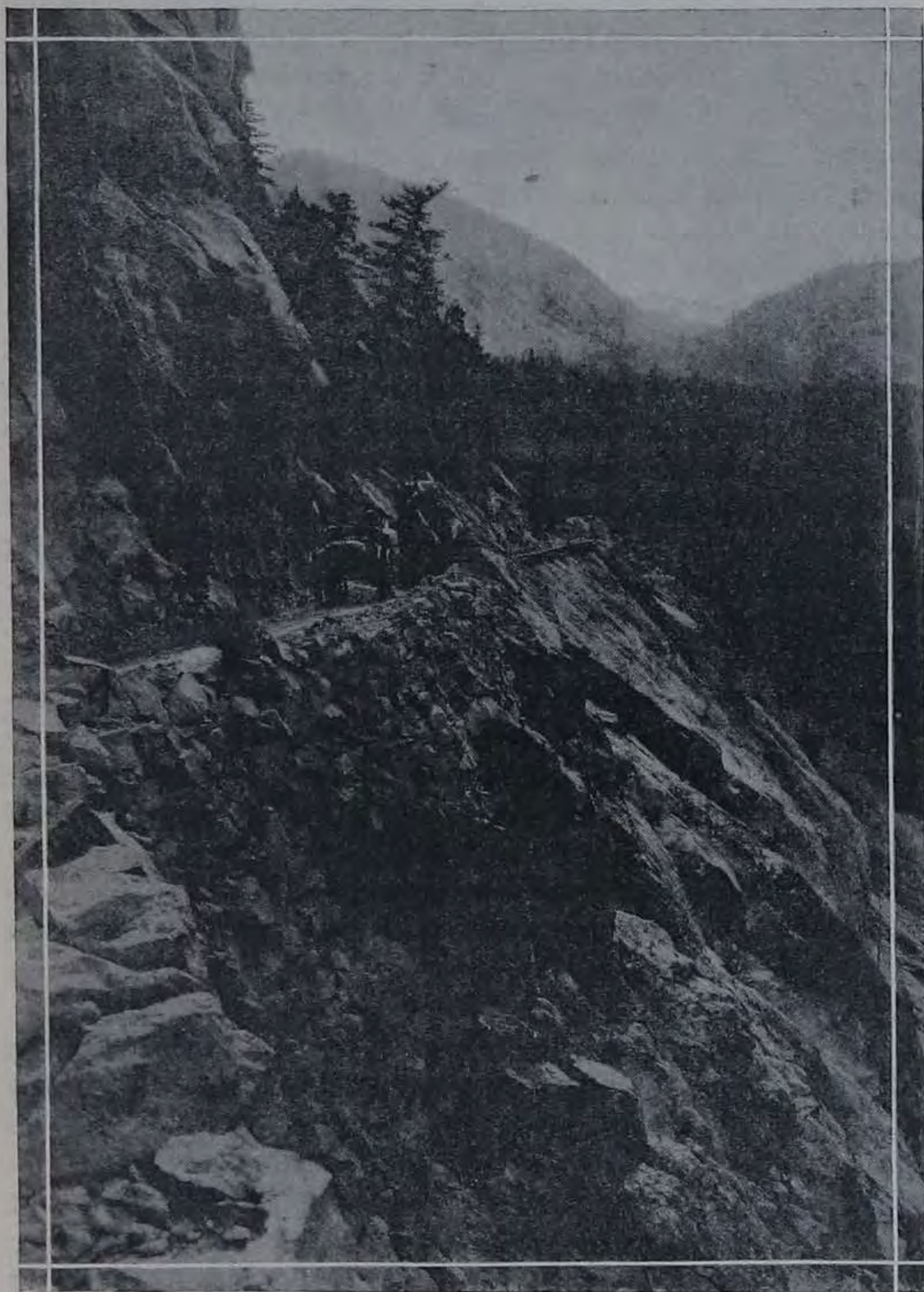

Travel Has Always Been Difficult in the Mountains of the West.

needs of the Forests became apparent. Steps were consequently taken to work out a plan of road development for each Forest which would look to the construction, in the order of their relative importance, of all the roads needed



during the next 10 years. These plans have been completed and are brought up to date each year. Studies are made of the need and importance of each project, as shown by the effect it will have upon the opening up of the National Forests and the development of the near-by communities.

In order to obtain the maximum results, cooperation on the part of the State or county is ordinarily required, but may be waived in exceptional cases. Such cooperation is usually made in money, but in many localities where ready cash is scarce the settlers often find it easier to give their work or that of their teams for a specified period.

All projects to be undertaken are selected and arrangements made for their financing by the Forest Service. Most of the larger projects are constructed under the supervision of the Bureau of Public Roads. On the smaller projects the entire work is carried out by the Forest Service.

There is an endless variety in the roads under construction and those to be built. They vary all the way from shooting out a rocky point in some well traveled route to the construction of 70-odd miles of new road. On some of them, in the more sparsely timbered parts of the Southwest, construction will be largely a matter of ditching and crowning; on others, in the Northwest, clearing the right of way alone is in itself a big job; and on still others the road must be blasted out of solid rock, and progress must be counted almost in inches. There are roads through splendid open stands of pine that follow long tangents; there are others which wind in and out of narrow canyons, across wind-swept ridges, and along the foot of towering cliffs to gain some distant pass.

The needs which these roads will meet are as varied as the character of the country they traverse. Some, like the Yaak Valley Project in the Kootenai National Forest in Montana, will connect outlying settlements, until now dependent upon a narrow trail, with their supply points and markets. Others, like the Trinity River and Klamath River roads in California, will form links in through routes at the same time that they give scattered ranches an outlet for their products. The Bitterroot-Bighole road in Montana connects two prosperous communities, each particularly adapted to certain kinds of agriculture and each needing the products of the other, which are separated by high mountains.

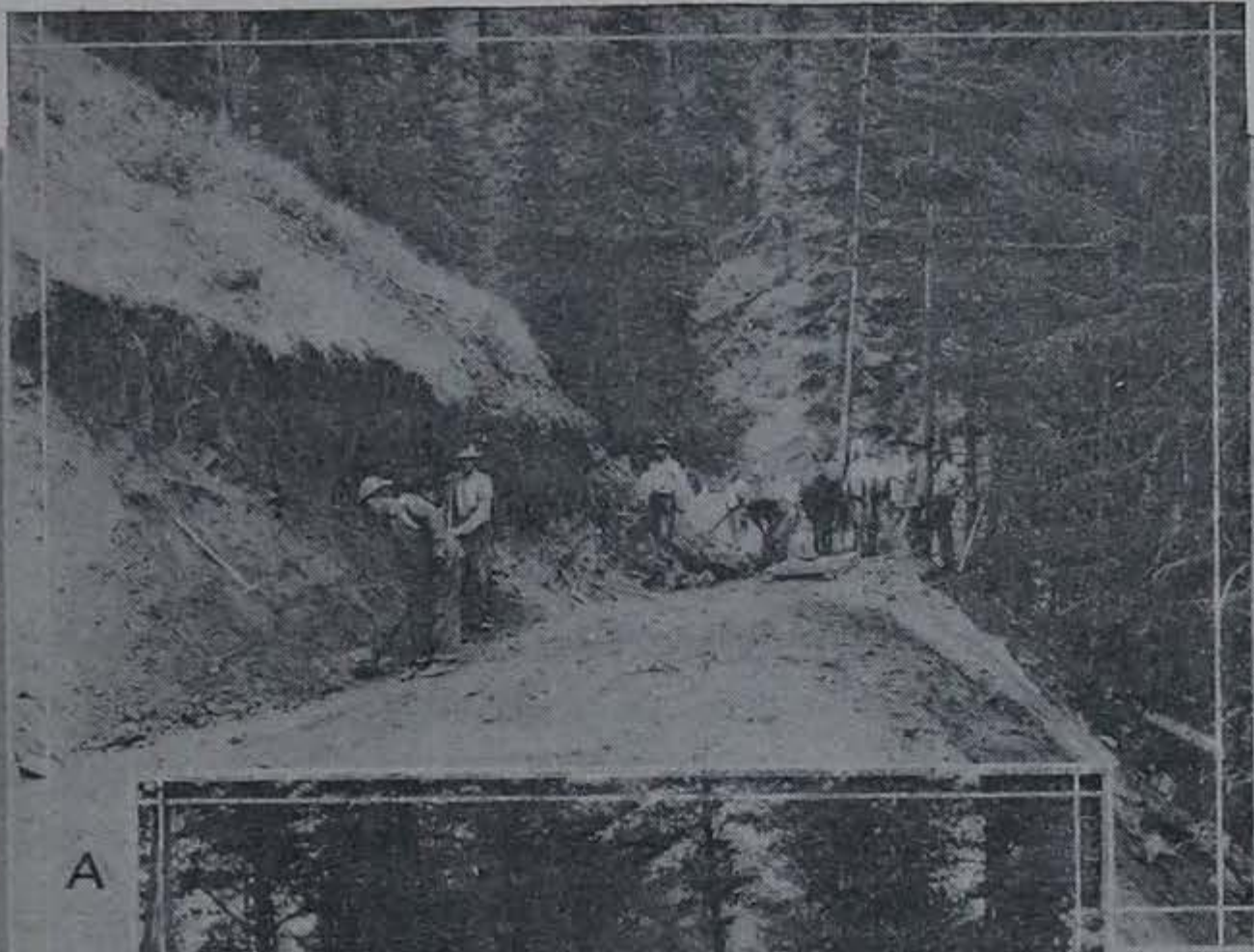

A



B

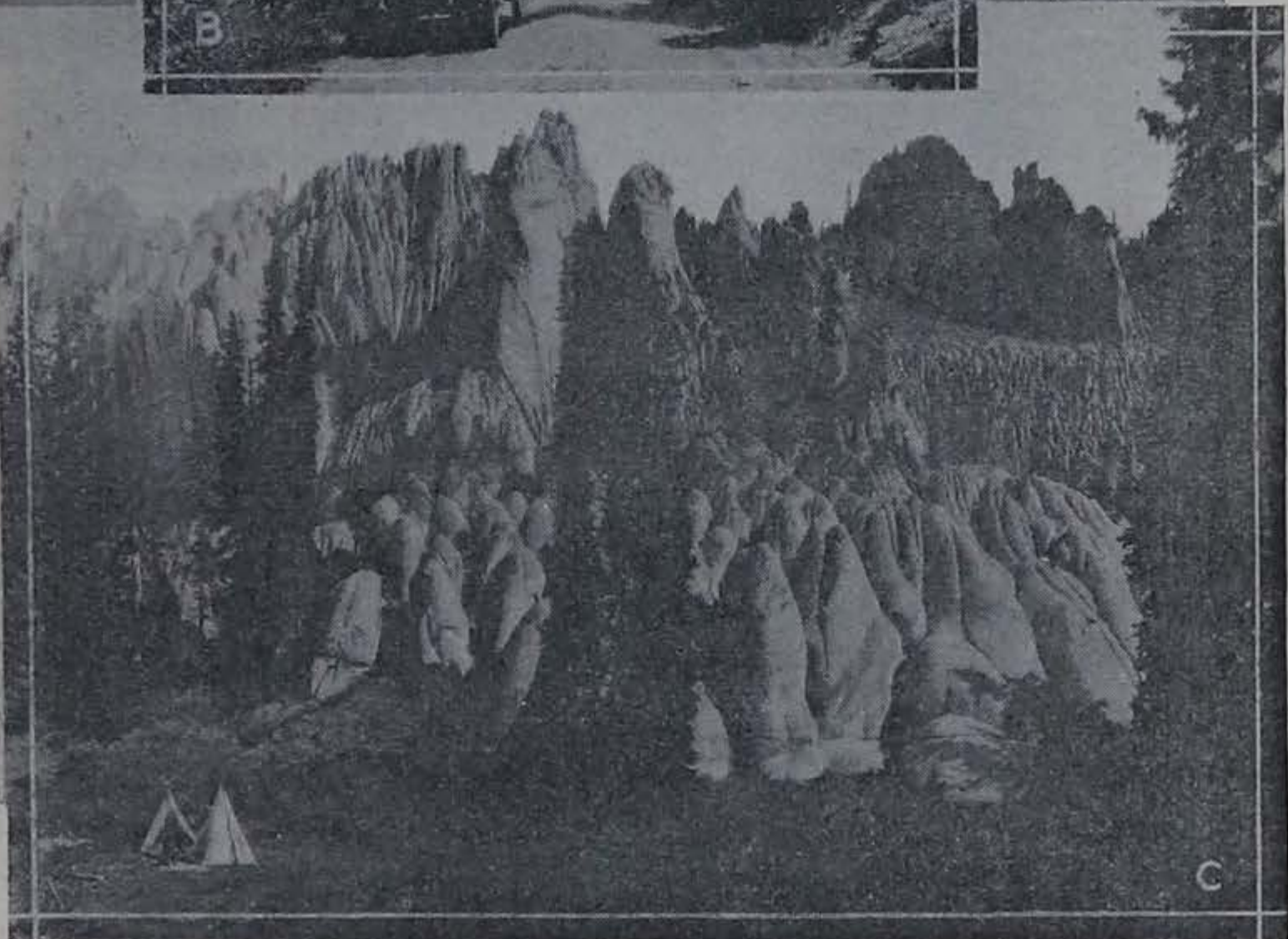

C

A. A new Road Along an Old Route, Blewett Pass Project, Washington.  
B. A Shady Nook on a Forest Road.  
C. A Camp in the Heart of the Hills.

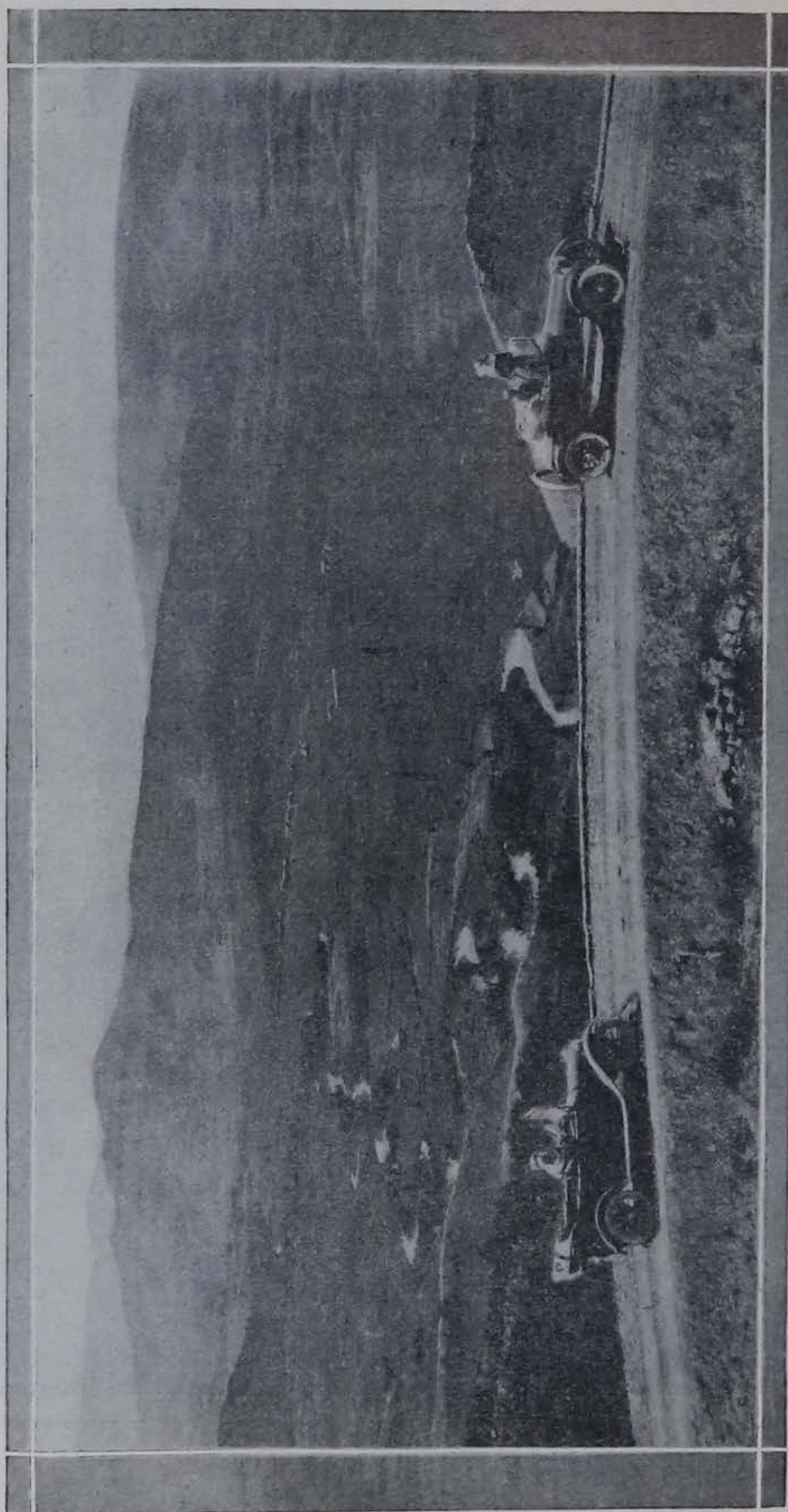

Motoring Along the "Top of the World" on the Rabbit Ears Road, Colorado.

The first year this project was completed more than 500,000 pounds of fruit alone was hauled from the Bitterroot Valley into the Bighole country.

Practically all of the roads will open up to tourists large sections which have heretofore been inaccessible to motor travel. Some roads are being built primarily to enable the public to see and enjoy the beauties of the mountain forests. The Laguna Project in California was constructed solely for the purpose of opening an attractive area in the Laguna Mountains to residents of the Imperial Valley, where during the summer months the heat is well-nigh unendurable. The Mount Hood Loop in Oregon and the Ketchum-Clayton road in Idaho will each allow vacation seekers to motor into sections where the beauty and grandeur of the mountains beggar all description.

Many of the roads follow long-traveled routes or have a close association with local history. The Fourth of July Canyon road follows the route chosen by Capt. John Mullan on his expedition from Fort Walla Walla to Fort Benton, then the head of navigation on the Missouri River. The white pine tree on which he carved the date—July 4, 1861—on which he chose the route, is still to be seen a short distance to the side of the new road which has replaced the original way. The blaze and the lettering are as distinct as on the day they were made.

Over the route of the Bitterroot-Bighole road, already mentioned, Chief Joseph led his band of valiant Nez Perces in his endeavor to avoid a battle with the whites. At the Bighole battlefield, to which this road leads, he was overtaken and attacked by the regular troops and a few volunteers. After the surprise of the first attack, however, the whites were outgeneraled by the wily chief, and after heavy losses were driven into a small gulch and surrounded. They were saved from annihilation only by the coming of the night. The Nez Perces, who were anxious to avoid further fighting, slipped away under cover of darkness and began what is considered one of the ablest retreats in military history, for the pursuit was taken up a few days later by fresh troops. Encumbered though they were with squaws, papooses, and household goods, Joseph's superb leadership enabled the Indians to lead troops under General Miles a

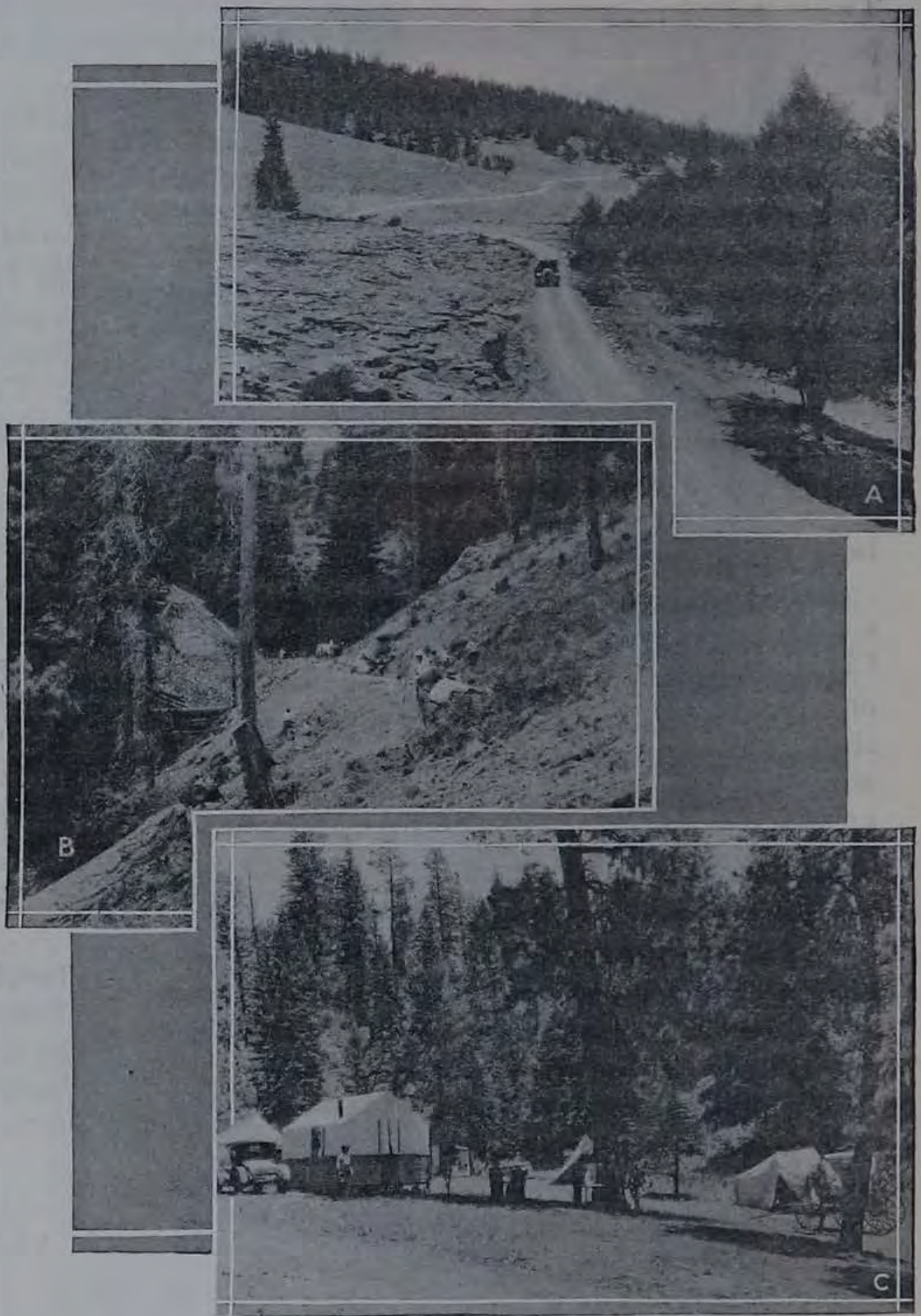

The Road in the Making.

The Lure of the Open Road.

A Summer Camp by the Wayside.

chase that stretched over hundreds of miles and that ended only when the Indians had almost reached the Canadian line. The Clifton-Springerville road in Arizona penetrates the favorite haunts of Geronimo and his band of Apaches,



A Forest Service Travelers' Registry Booth.  
The "Fourth of July Tree," Marked by Capt. John Mullan, July 4, 1861.  
"Fisherman's Luck" on a National Forest.

who brought terror to the countryside a comparatively few years ago.

And so the list might be lengthened indefinitely, for there is romance in these Forest roads—the romance of the trapper, prospector, Indian fighter, cowboy, and emigrant. For each has trod the routes that these roads follow; each has done the part which fate assigned to him and then passed on; each

has made it easier for the man who came behind, until for many years there has been no part of our West where men may not go with safety.

Not that the winning of the great mountain region is complete. What has been done toward building roads into the National Forests is hardly a beginning of what is needed to make these great public properties play their full part in the Nation's life. The roads that have been built and those for which funds are in sight are only a first step. Many years must pass before there is an open road through all the Forests. But a start has been made; the work goes on.

The old West has gone, never to return. The last frontier has passed. New roads stretch up the valleys and across the passes. At night perhaps the ghosts of Lewis and Clark, Carson, Bridger, Fremont, and all the others on the long list of pioneers who heard the whisper and "crossed the range to see," watch powerful motor cars speed along the same routes over which they toiled so painfully. Do they mourn the passing of the last frontier? Not they! Rather they say to each other "I told you so," for they were empire builders, those old pioneers, and with the coming of the open road through the Forests they see the completion of the winning of the West of which they dreamed.



# Influence of DEPRECIATION OF EXCHANGE on Agricultural Production

By ALONZO ENGLEBERT TAYLOR,  
*Assistant to the Secretary of Agriculture.*

MUCH has been written concerning the influence of depreciation of exchange upon the manufacture of industrial commodities with reference to domestic consumption and to exportation. To the extent that the farmer is engaged in productive consumption, the influence of depreciation of exchange is equally obvious, though scarcely susceptible of measurement. But the agrarian in a food-importing country, under circumstances of pronounced depreciation of currency, is placed in a situation of particular instability.

Agriculture in most countries of Europe has been operated collectivistically for four years. The peasant has not been a free agent. To a greater or lesser extent he has been compelled to follow an official program. The acreage he was to cultivate and the division of this acreage among the different crops were prescribed. In particular, the acreage to be devoted to grains, potatoes, and sugar beets was marked out by program. The number of domesticated animals that the peasant could keep, the degree of breeding, and the number that should be killed each year were regulated by enactment. The disposition of the produce, both plant and animal, was under strict supervision, including the food of the peasant's own family. Prices were fixed for most of the products of the soil and of the dairy and animal husbandry. And in many countries the articles required by the agriculturist—seed, machinery, fertilizer, containers, and fuels—were priced by regulation. In short, agriculture was collectivistically operated except for the risks, which were left to the farmer. It was necessary to set prices high in order to secure production, with the result that everywhere in



Europe agriculture has been unusually profitable during the war. In addition to this, the European peasant has been more successful in escaping taxation than the industrial producer; and in every country it has been possible for him to indulge in illicit trade, with the result of further increment in income. As against this, the period of reconstruction has placed the European peasant in a dilemma, the outcome of which neither he nor the governing authorities can foresee. Illustrations for France and Germany will make the situation clear.

The fixed price for wheat for the grower for the crop of 1919 in France was 75 francs per quintal. The offer of this high price had the result of a relatively good acreage, but the yield was low on account of unfavorable weather. The amount of wheat available for consumption during the year is in the neighborhood of 4,500,000 tons. This is sold to the miller for 55 francs per quintal. This 20 francs has constituted an indirect subsidy of bread which if applied to the entire crop would have represented 900,000,000 francs. France needs to import in the neighborhood of two and a half million tons of wheat if she is to maintain anything like the prewar consumption of bread. Seven million tons of wheat must be considered a modest intake for the French people when the relative scarcity of other foodstuffs is considered. With the franc worth 9 cents in international trade, the bushel of wheat in New York will cost the French buyer, in terms of dollar credits, 27 francs, or 99 francs per quintal. The cheapest freight rate available to the French importer, who must charter a foreign bottom, is a little over a shilling a bushel. Since he must purchase this carriage with the depreciated franc, transportation of the quintal from New York to a French port will cost him in the neighborhood of 11 francs, bringing the total cost of the wheat up to 110 francs per quintal. This wheat is also sold to a miller at 55 francs per quintal. The state subsidy on the imported wheat would amount to 1,375,000,000 francs. If this program had been carried out, the national bread subsidy of France during the crop year 1919 would have reached the appalling figure of 2,275,000,000 francs, corresponding to practically 55 francs per capita. Fortunately for the future of France, it was decided in January, 1919, that the

millers must pay to the government the full cost of the wheat, whether domestic or imported, and the cost of bread must rise in proportion.

Germany furnishes the second illustration. The fixed price for wheat of the crop of 1919 was 330 marks per metric ton, which with premiums for early thrashing was expected to bring the mean price to about 360 marks. Rye was priced a little lower. The crop of wheat and rye is supposed to yield a millable supply of 9,000,000 tons, sold to the mills at cost. There is a bread subsidy in Germany, but it is applied to the cost of the finished bread, as in England, and not to the wheat on its way to the mill. Germany requires 2,000,000 tons of wheat. If she were to purchase this wheat in New York with dollar credits, secured through forced sale of German marks at 2 cents, the wheat would cost 4,400 marks per ton. She must also purchase ocean carriage at 2 cents per mark; so that with transportation added the ton of wheat would cost her in Hamburg in the neighborhood of 5,000 marks. Now as a matter of fact the food controller is not securing the wheat from the peasants for 360 marks; he is paying all the way from 700 to 1,000 marks per ton, because the peasant also figures on the depreciated mark, and the government is not in position to coerce the peasant into delivery of the grain at the price in marks fixed before the armistice. But at a thousand marks per ton for domestic wheat the imported wheat is still 5 times as expensive as the domestic grain.

I have selected American wheat as the illustration, assuming the price to be identical with the world price. As a matter of fact, when the freight rates are equalized for the different parts of the world concerned, the distant wheat-exporting nations can lay down wheat in the world market for something like 10 cents a bushel below the figure resulting from the fixed price to the American grower.

A wide difference in price between imported and domestic wheats creates for the government of the country concerned urgent, delicate, and precarious problems in the direction of both consumer and producer. If the imported wheat is sold at its cost price, it is beyond the reach of the poorer or even middle classes. If it is sold at the price of domestic wheat, this necessitates a huge subsidy in the form of paper

money that prospectively will one day have to be redeemed at a much higher rate. Printing paper money to make food less dear for more or less unemployed masses represents an appalling violation of the first principles of economics in the administration of national fiscal affairs. But the government may not be strong enough to resist the economically evil temptation. One must fully evaluate the urgency of such a situation in order justly to appreciate, and not condemn though not condone, the frantic efforts now being made by Europeans to purchase wheat on credit. Taking the arbitrary import figure of 14,000,000 tons of wheat, that before the war cost Europe approximately \$600,000,000, this could, during the month of January, have been purchased for use in Europe in terms of gold for about \$1,500,000,000. But in terms of depreciated currency, in the amounts required by each importing nation and calculated at the current rates of exchange of that month, the cost would have been over \$4,000,000,000, in terms of par. From the point of view of the consuming population, comparison of the three figures (600-1500-4000) illustrates that the problem is for the government concerned crucial and critical.

From the standpoint of the wheat grower in the importing country, however, the problem is just as critical, though not so crucial in the immediate sense. The government concerned must decide between fixing a price for the new crop of wheat and setting the market free. If the market is set free, the price of home-grown wheat in the particular country will tend to rise to the price of foreign wheat. If a fixed price is to be established, this must be such as to convince the peasant that it will offer an adequate remuneration in view of the high prices that he must pay for everything on account of inflation of currency. The largest acreage would probably be obtained by setting the market free. To what extent, if at all, the price of home-grown wheat would be higher with a free market than in the case of a fixed price, if that price were high enough to insure anything like the same acreage, is something that no one in Europe will venture to answer. Yet an answer must be attempted and a policy defined in one direction or another.

For the government concerned the problem centers about three facts:

(1) The depreciation of currency, to which the price of the imported article is directly (or more than directly) proportional.

(2) The elevated prices of domestic commodities.

(3) The wage level of the workers.

Now while the price level of a domestic article tends to rise whenever the imported article appears in the market, it can not in fact attain the level of the price of the imported article when the depreciation of exchange is profound. On the other hand, the sympathetic rise in the price of the domestic article toward the level of the imported article will still be very marked when considered in connection with the buying power of the mass of consumers. The wage curve in continental Europe has lagged far behind the curve of cost of commodities, for the simple reason that unemployment is widely prevalent, owing to palsy of industry, disorganization of transport, lethargy in the working classes, and timidity among entrepreneurs.

Naturally the standard of living has fallen greatly, in many countries to such an extent that the death rate has risen. It is a fair statement to make for Germany in December, 1919, that wages were 2 or 3 times the prewar level, domestic commodities (except where subsidized) 5 times the prewar level, and foreign commodities when purchased at current rates 20 times the prewar figure. In the summer of 1919 in Vienna the writer saw imported flour advertised for sale in a shop window at what amounted to 62 times the prewar price of Austrian flour! Accepting the figures stated for Germany as the basis of discussion, if the German peasant could sell his wheat for 5 times the prewar price and pay not over 3 times the prewar price for labor and not more than 5 times the prewar price for the ordinary commodities, including machinery and fertilizer, it would seem as though such a fixed price ought to be regarded as sufficient. But on the one hand, the peasant fears that he will sell at a time when the mark is worth less than it is now; and on the other hand he sees no reason why his wheat should be priced so much below that of imported wheat. The German peasant, of course, does not understand the operations of international exchange. He merely compares the two prices and is dissatisfied. When in the summer of 1919 German bacon sold

in the shops for 60 cents while American bacon sold for \$2.80 (par prices) the most violent dissatisfaction was provoked in the peasant. The natural temptation of the peasant to sell his produce through illicit traffic is greatly exaggerated by wide contrast between the sales price of domestic and imported foodstuffs. Striking contrasts in prices tend everywhere to social unrest.

But this is not all. The situation presents one further unfortunate angle. The peasant has reached the point in continental Europe when price in terms of currency holds for him a steadily diminishing interest, because he can do so little with the currency after he gets it. What the peasant wants is commodities, not money. In the present Roumania and in the Kingdom of the Serbs, Croats, and Slovenes are 2,000,000 tons of wheat that could be regarded as exportable surplus if market conditions were normal. These peasants do not wish lei or dinar or crown, or even lire or franc; they wish shoes, clothing, hardware, corrugated iron, agricultural machinery, cloth, harness, and other commodities essential to their work and existence. This is more or less true of every nation in Europe except the United Kingdom, Scandinavia, Holland, Switzerland, and Spain, though of course in France and Italy to a much less extent true than in Germany or Poland. But it is everywhere a fact that the peasant measures money by the facilities of his local market; he estimates price by what he can buy in the local market. In the absence of commodities price has little attraction. The peasant knows there is no use in hoarding paper money; and he is also beginning to realize that for the immediate present there would not be much more use in hoarding gold. Peasants in Southern Russia have been known to refuse gold for wheat and insist on commodities instead, simply because they realized that the possession of commodities was a source of strength and the possession of gold a source of weakness.

These factors had not become sufficiently clear at the time of the fall planting of grain in Europe in 1919 to have exerted a positive influence upon the Government or the agrarian classes. But they are exerting a positive influence upon program and performance of agriculture at the time of the spring planting of 1920. And they will exert a

still greater influence at the time of the planting of wheat and rye in the fall of 1920.

Inversely, the same problem confronts the producer in the exporting nations. If the wheat growers in Canada, the Argentine, and Australia, whose markets lie largely outside of domestic consumption in their own countries, have to face selling grain to distant importing nations whose currencies vary from 10 to 40 per cent of normal buying power, they will not be encouraged to plant large acreages. If, on the other hand, they believe that the sale of the exportable surplus in each country stands a good chance of being accomplished through the extension of credits so that the importing nations can purchase at the gold price, they may be tempted to plant large acreages. And, naturally, the domestic prices in these countries will be influenced by the buying power of the importing nations of Europe. There is no scarcity of commodities in the wheat exporting countries; it is merely a question of price. But the high prices of commodities that the wheat grower must purchase make him pause when he considers the acreage he is to plant to a crop, the largest part of which must find a market abroad under conditions rendered so unstable by depreciation of currency as to lie outside of any estimate of probability. In the final analysis, one can not sell unless one buys, and this holds even for foodstuffs essential to continued existence. And the farmer, like the manufacturer, may reach the place where he must decide between selling on credit and contracting his plant.

Lastly, the grain grower in Europe and in the grain-exporting nations of the world is faced with the necessity of return to the normal practices of agriculture. Everywhere has occurred a break in the customary rotation, diversification has not been maintained, fertilizer has been lacking, and cultivation has been inefficiently done. In a word, during the last five years the soil has been exploited, not developed. A return to the development of the soil is everywhere the order of the day. But correct agriculture is one thing in a normal world, where returns can be foreseen. It is a totally different thing in an abnormal world, where the farmer fears that correct agricultural practice may result

in large immediate loss or at least in failure to secure large immediate gain. Correctly analyzed, the situation with the producers in the importing nations of Europe and in the exporting nations of the world are the reverse sides of the same problems. And it is clear that until the agriculture of Europe can become normal in technique and economics, agriculture nowhere in the world will be normal in technique or economics.

# PRACTICAL POINTS IN HOG CHOLERA CONTROL

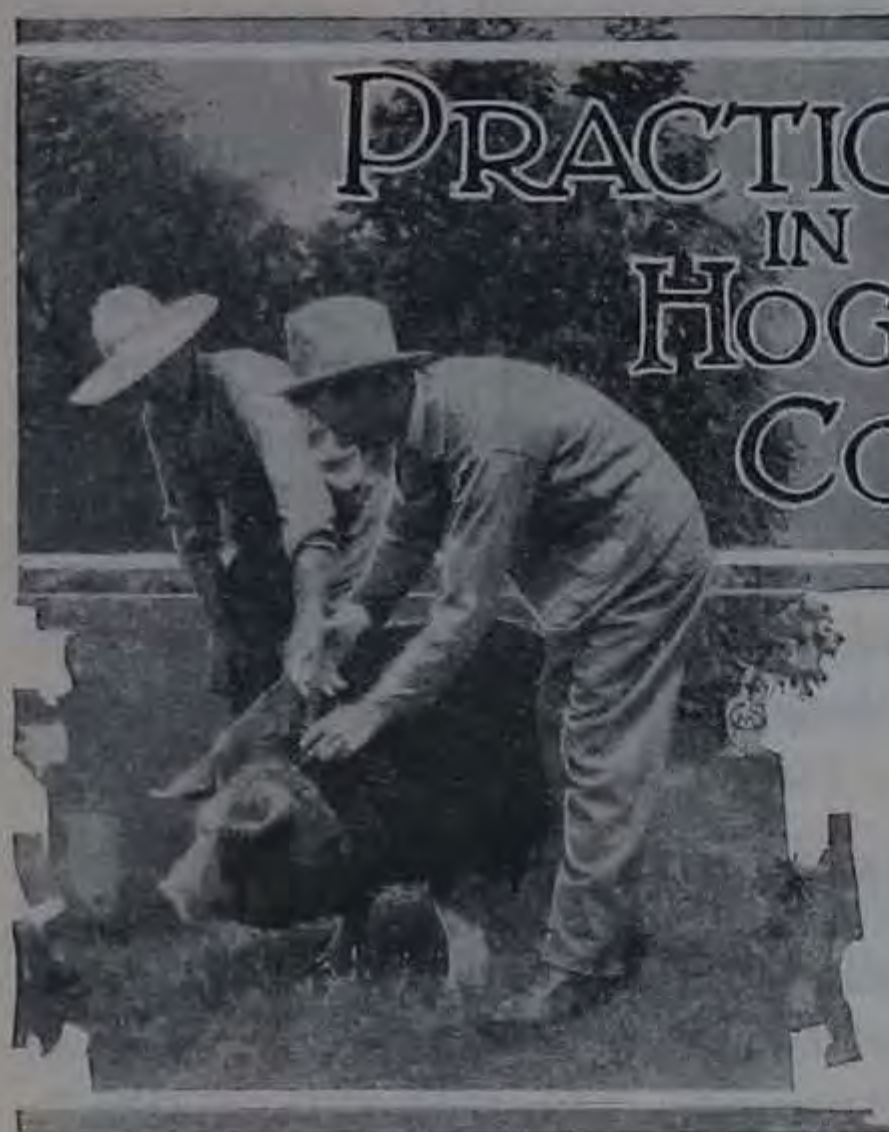

By T. P. WHITE,

*Division of Hog-Cholera Control,  
Bureau of Animal Industry.*

THE efforts put forth by farmers and stockmen during the late emergency in building up large herds

of domestic animals bid fair to continue even under normal conditions. Economic facts point to the necessity for continued increased production of meat-producing animals, and farmers, realizing that swine growing is perhaps the most profitable phase of live-stock production, have given particular attention to the improvement of their swine herds. They have selected for breeding purposes a better quality of stock, in point of prolificacy and marketable variety. They have been quick to recognize and adopt the type which brings the greatest and quickest returns for money invested, and their activities in that respect have been amply rewarded. The number of hogs on farms of the country January 1, 1919, totaled 75,587,000 according to the Bureau of Crop Estimates. At an average valuation of \$22.04 per head, by the same authority, that number of swine represented an item of national wealth amounting to \$1,665,837,480.

An industry of such magnitude must have ample protection against possible losses and reverses. As a national asset it calls for the united action of State and Federal authorities in the adoption of means for safeguarding the investments and interests of those whose revenues are derived chiefly from this source as well as to protect the food supply of the general public. With this realization, the Department of



Agriculture is continuing its efforts to control the most dangerous factor in swine production—hog cholera.

With the available funds at hand assistance has been extended to the various States in which the extent of hog raising justifies the expenditure. In return it is expected that State authorities will endeavor to lend a full measure of cooperation, at least in matching the Federal help with the same amount of funds, by applying quarantine and enforcing rules and regulations necessary to restrict the movement of infected animals, by the proper disposal of hogs dying from cholera, and by the cleaning and disinfecting of premises.

#### LESS HOG CHOLERA IN SWINE MARKETED.

The work already accomplished in the reduction of losses from cholera and the placing of the swine industry on a safe and sound basis is a matter of record. The following striking figures show the number of hogs found affected with that disease and destroyed as unfit for food at the various slaughtering establishments under Federal inspection within the last five years. During the year ended June 30, 1914, the period of the last heavy outbreak of cholera, 116,107 hogs were condemned at Federally inspected establishments throughout the country. That year marked the beginning of systematic efforts by the department, in cooperation with State authorities, to suppress and control hog cholera. The following year the number of hogs found at these centers and condemned at ante-mortem and post-mortem inspections on account of cholera dropped to 108,955. For the fiscal year 1916 the number was reduced to 75,894; in 1917 to 39,519; in 1918 to 24,721; and in 1919 to 26,316, showing a reduction of over 77 per cent in the five years. The condemnations in 1919, though more numerous than in 1918, were a smaller percentage of the hogs slaughtered.

As stated in previous publications, the ultimate object of the work is the complete eradication of hog cholera. However, many factors have retarded progress. Errors both of omission and of commission have impeded efforts to eradicate the disease from American farms. That outbreaks have been promptly suppressed and controlled generally is regarded as encouraging, considering that at the beginning of the

campaign some communities had but a scant knowledge of the ways in which the infection was spread, had little conception of the nature of the ailment, took no precaution to avoid exposure, and had a prejudice against the serum treatment. In many cases even distrust of the activities put forward was evident. These handicaps have been overcome, but others remain to be met. The success of the work depends largely on the measure of cooperation extended by State agencies, live-stock producers and dealers, and practicing veterinarians. Among the problems still incompletely solved and which need special attention are: The failure or relaxation on the part of those farmers and officials concerned to observe prescribed methods to prevent the introduction and spread of infection; the lack of restriction in the traffic in infected animals; the improper disposal of hogs having died of cholera; the aversion on the part of owners of infected premises to clean and disinfect; the promiscuous use of hog-cholera virus in the treatment of the disease by irresponsible or incompetent individuals; and the sale, purchase, and transportation of cholera hogs by unscrupulous dealers. All these things will have to be met either by laws, rules, and regulations or through voluntary action based on a mutual understanding in order to obtain that full measure of cooperation essential for the complete extermination of hog cholera.

#### GARBAGE FEEDING AND STOCKER HOGS.

The extensive use of garbage as a feed for hogs and the large number of swine being shipped back to farms from public stockyards to be finished for market have been sources of much difficulty in the control of hog cholera. When the feeding of garbage is carried on in isolated locations, losses from cholera have not been very extensive, especially when the lots were well fenced and the animals had received the immunizing treatment. All such places, however, are considered infected centers, and farmers and swine owners in the vicinity should be on guard to prevent infection being introduced from those sources to their premises. To safeguard against possible losses, herds of hogs on farms within a certain radius—usually about 5 miles—should be kept immunized against cholera at all times. Under this

method of hog feeding, however, much trouble has developed from individuals who have undertaken to raise hogs on a small scale on a portion of a farm or in suburban sections. Such efforts have been made without proper equipment and the hogs fed were not immunized. The results have been, in many instances, the loss of animals, the creating of infection centers, and the spread of cholera. When fed to swine not given the cholera-preventive treatment, garbage should first be thoroughly cooked, for the reason that pork trimmings in the garbage may carry hog-cholera virus, though there are certain drawbacks, from the standpoint of nourishment, when ordinary mixed garbage is cooked. Simultaneous inoculation to make the animals immune to cholera, therefore, is advised as the best protection for garbage-fed swine.

The practice of shipping feeder hogs back to the farms from public stockyards has been another source of anxiety to those engaged in controlling hog cholera. Although such animals receive the preventive treatment at the point of origin, the handling, loading, and shipping immediately after the treatment—also the long distance hauled, the exposure to bad weather conditions, and other factors unknown—have in some instances interfered with the degree of immunity acquired. At certain dates after reaching destination some of these hogs have become susceptible and developed cholera, and in many cases before the ailment was recognized and properly treated severe losses have occurred, not only in the shipments but in the herds originally on the farms. New stock should in all cases be kept apart from the hogs already on the premises, the animals should be closely watched, and if evidence of disease appears the services of some one competent to make a correct diagnosis and to give the proper assistance should be promptly secured.

#### THE MONEY VALUE OF SANITATION.

With all the information disseminated, the demonstrations given, and the knowledge of cholera broadcasted, there still exists a lack of cooperation in the cleaning and disinfecting of infected premises. This is due, no doubt, to the security felt by the owner of hogs in the use of antihog-cholera serum. The feeling of security is well founded, but should this attitude become general and all farmers and stock raisers de-

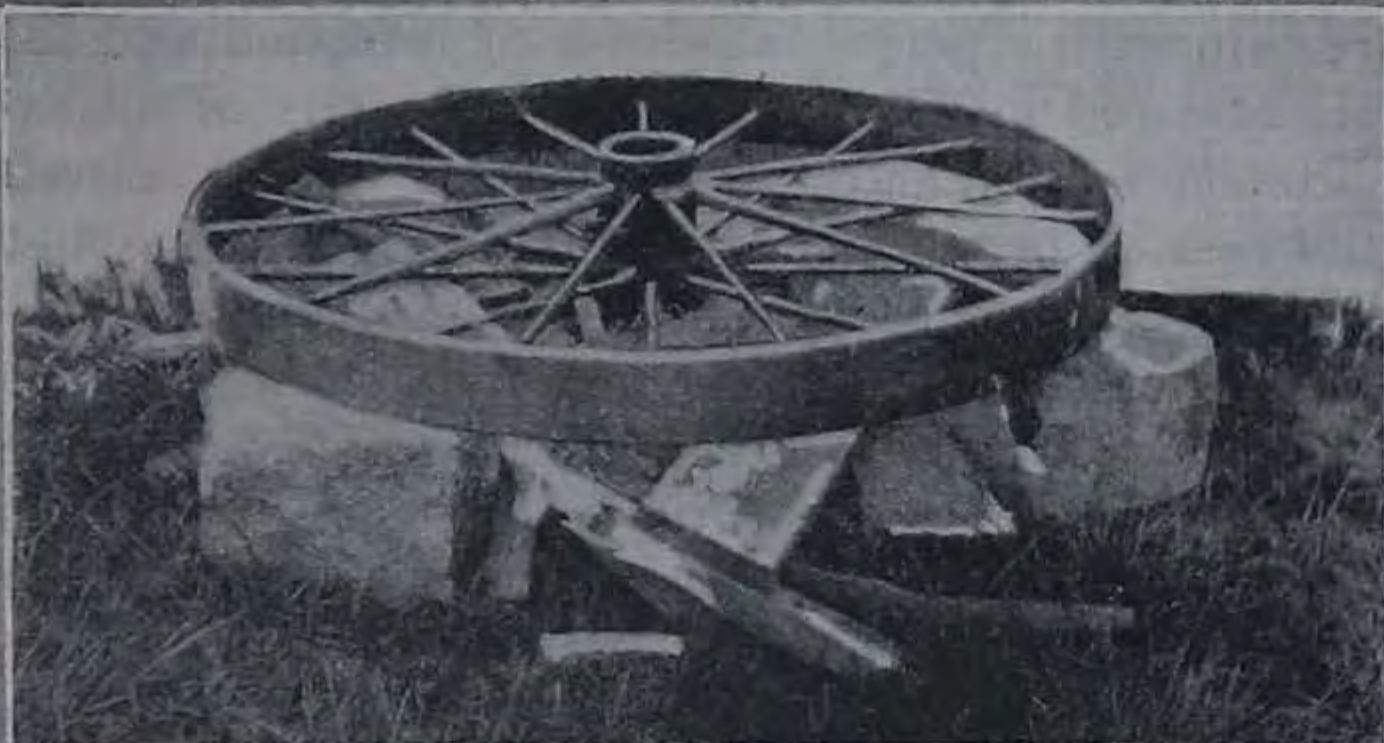

**Burning, a Safe Way to Destroy a Diseased Hog Carcass.**

A metal wheel is placed on stones with wood underneath. The carcass is put on the wheel and slashed so that the fire will easily reach the fat.

pend solely on the serum treatment for protection, the country will remain with a perpetual source of infection, and the use of millions and millions of cubic centimeters of an expensive product will be necessary each year, adding materially to the cost of production. In 1918, figuring at a low estimate, approximately \$5,280,000 worth of serum was produced, all of which, plus the cost of administering it, was paid by American farmers. Even with that high legitimate expense there occurred a loss of over 2,000,000 hogs from cholera. While this is a pronounced reduction in the number of hogs lost in previous years, the monetary loss, owing to the high value of the animals, still amounted to more than \$60,000,000. Truly, this is an unwarranted waste, particularly in these times of reconstruction, when economy should be the watchword. A few days each year of scraping, cleaning, and disinfecting buildings, pens, and small lots to which hogs have access will be time well spent and also will add much to the efforts being made to reduce the preventable losses.

#### FAKE REMEDIES FOR HOG CHOLERA.

Numerous mixtures and combinations of drugs and chemicals are still being offered to the public and represented as being cures for hog cholera. These remedies vary greatly in appearance and consistence. Some are powders and others are sold in a liquid form. Many different drugs and chemicals are used in compounding these so-called hog-cholera cures. Sulphur, charcoal, black antimony, common salt, arsenic, and Glauber's salt are not infrequently used, and even the ordinary coal-tar dips have been represented and sold as being effective cures for this disease. Tests properly conducted have uniformly shown these so-called remedies to be valueless as cures for hog cholera. Usually before fake remedies are discovered and excluded from the market, however, many farmers are victimized.

Oftentimes home remedies are used by hog raisers with the honest conviction that cholera has been cured or avoided by their use. An employee of the department stationed in a Southern State some years ago discovered several kinds of home applications being used for the disease, such as turpentine, lye, and tobacco juice, and on one occasion was confi-

dentially informed, as a favor, that as a preventive treatment the only infallible agent was "skunk meat." The informant very modestly denied himself any credit for the discovery. He narrated that when a boy he had gone hunting, and returned home with a skunk. Fearing the just wrath of his father for his acquisition he promptly skinned the animal, secreted the pelt, and threw the carcass in the hog lot, where it was quickly devoured by the hogs. Lo and behold! cholera, which had been rampant on that farm and had caused severe losses in previous years, disappeared, and never had another case of the ailment developed on those premises. It took a lengthy and tactful talk to convince the old gentleman that his conclusions, though honestly drawn, were of no weight and that his remedy was just as worthless as all the other home remedies. It was pointed out that either the disease existing had been incorrectly diagnosed, or if cholera was actually prevalent it had run its course, and that the feeding of skunk meat or any other of these so-called cures could have no effect whatever in preventing or curing hog cholera.



One Method by Which Hog Cholera May Be Spread.

Hogs in running streams may be infected from farms upstream.

In the early days of serum production many instances were found where "substitute" blood had been sold and used to immunize herds of swine. In one case where an inspector was called to investigate the cause of hog losses on a farm he was told that the existing disease could not be cholera, as the animals had been treated with "serum blood" two weeks before. As the herd showed positive evidence of cholera, inquiries brought out the fact that the farmer had been the victim of unscrupulous practice resorted to for money. Among other questions the owner was asked if he thought the serum used was fresh and potent, to which he quickly replied that it could not be any fresher, as it had been drawn from a mule and injected into the hogs at once. And he added: "She's the healthiest mule on my farm." Of course, the blood taken from the mule was of no more value as a serum than water taken from the well.

The moral has been told repeatedly. There is no recognized preventive treatment for the disease except the anti-hog-cholera serum properly administered and followed by judicious care of the animals after the inoculation. This, coupled with the quarantine of infected premises, the isolation of sick hogs and newly purchased stock, the burning of dead ones, and thorough cleaning and disinfecting of swine quarters, will in time, if generally adopted, bring us to the goal we have set—the extermination of hog cholera.

# MARKETING<sup>AND</sup> PURCHASING DEMONSTRATIONS IN THE SOUTH



By BRADFORD KNAPP,  
*Chief, Office of Extension Work in the South.*

TWO distinct and somewhat different things are now being described under the general term "demonstrations:"

- (a) An act performed by an extension worker with his own hands to illustrate an agricultural or home economics practice in the presence of persons who are expected to acquire the information.
- (b) An act or series of acts in the production or sale of a farm product performed by a farmer, or some member of his family, on his own place, or by a community, or group of farmers, or members of their families, for the purpose of perfecting themselves in improved agricultural practices, and at the same time assisting others to acquire the same information.

The difference lies in the fact that the first class of demonstrations is by the person giving the information; and the latter class, and much the more important of the two, is by the person acquiring the information.

Of all types and kinds of demonstrations, by far the most difficult are those in cooperative marketing and the purchase of supplies. Such demonstrations, as we shall see later, should always fall within the second type described above. They involve large undertakings, business skill and experience, and a fund of knowledge beyond that necessary for the ordinary demonstration of a purely productive character. They call for a very high quality of leadership on



the part of the extension worker. To influence a group of men to organize, to take personal and collective responsibility, to decide important business matters intimately connected with their collective and individual gain or loss, and to have the entire undertaking result ultimately in the true spirit of cooperation and in good business methods and successful operation, is a very difficult undertaking. Such demonstrations are the real challenge to county agents and specialists in marketing. The very difficulty of the task constitutes one of its attractive features.

From the very beginning of the demonstration work in the South, county agents and those who have supervised their activities have felt impelled to deal with the important problems of marketing and purchasing of supplies. In fact, almost every real demonstration has involved something of a marketing problem. In writing up the results of a 5-acre demonstration in corn, invariably the county agents and those interested in the demonstration set down the sale of the crop and the profit per acre as the index of its success. Corn club and pig club boys, canning and poultry club girls, have always been taught to sell their product, either individually or collectively. Most demonstrations which involve the production of crops or live stock are incomplete until the product has been marketed and the entire financial undertaking successfully finished.

#### RELATION OF COUNTY AGENTS TO MARKETING DEMONSTRATIONS.

County agents and specialists in marketing are employed as public officers, and their salaries are paid in part from funds of the United States Department of Agriculture, part from the State college of agriculture, and part from some source within the county. The county fund is frequently used by the agricultural college as an offset to Smith-Lever funds. The majority of such county funds are appropriated by the county taxing body and are therefore public funds. That they may be in some cases otherwise obtained does not vary the rule, because, as stated above, such other funds are generally used as an offset and are therefore subject to the same rules as other public funds, for such they become on account of their use.

Such public officers in extension work are employed to disseminate among the people useful and practical information on subjects relating to agriculture and home economics and to encourage the adoption of the practices advocated. The whole service is an educational activity intended to ascertain the needs of the farmers and their families, assess their problems, and bring to them such knowledge, information, and experience as have been acquired elsewhere. The law creating this service never intended extension workers to be employed for the purpose of saving farmers the cost of ordinary personal service.

At what stage the work of a county agent, in a demonstration of either character as suggested above, may become a matter of pure personal service is difficult to say. No fixed rule can be laid down. For example, the extension worker, either specialist or county agent, may show a farmer how to grade and pack fruit or vegetables for market. He may have to repeat the instruction a number of times before the farmer and other members of his family become sufficiently proficient to rely upon their own resources. If he continues the operation of assisting them in grading and packing beyond the point necessary to impart the information thoroughly it becomes mere personal service and the public funds are being used to employ a man free of charge for a farmer.

The same principle holds in demonstrations in marketing and purchasing. If groups of farmers decide to organize for the purpose of marketing their products or purchasing supplies it is the duty of the county agent and extension specialist in marketing to assist such farmers and give them all possible information regarding the best methods of organization and correct business practices for such organizations, to assist them in adopting a proper constitution, by-laws, and rules for the conduct of business, to furnish them with practical information and instruction in grading, standardization, methods of packing, shipping, etc., and in general to bring them information which will assist such groups of farmers to organize properly, to avoid mistakes, and to transact their business successfully.

Neither the county agent nor the specialist in marketing has the right to actually engage in business performed for

the farmer or for groups of farmers, except such as may be necessary for the sake of demonstration, and it is doubtful whether this is ever absolutely necessary. Conditions in various counties and in different sections vary widely. It may be necessary to do more under one set of circumstances than would be necessary under another set. The county agent and the specialist can not go far wrong if they stick to the rule that when they go beyond such service as may be absolutely necessary in order to put on a good demonstration, and perform a service, free of charge, which ought to be borne by the business itself, and would have to be so borne if the farmers transacted the business themselves, they are outside the field of educational activity and performing a personal service. As said before, qualities of leadership are here shown in their strongest contrasts. The able and resourceful leader never finds it necessary or advisable to perform mere personal service; the man lacking in these qualities often goes far afield and has difficulty in extricating himself after the situation has existed for some time.

The main object of extension work of this character is to establish activities which will endure and become self-sustaining. If this is not done, it is not a good piece of business and therefore not a good demonstration. If, after the demonstration has been carried out once, the enterprise fails because the county agent's time is occupied with other and important work, it is a sure indication that the work either should not have been begun or else that it was not well done.

#### WHEN SHOULD DEMONSTRATIONS IN MARKETING AND PURCHASING BE UNDERTAKEN?

This is a difficult question. Generally speaking, such demonstrations should not be undertaken unless the marketing of products and the purchasing of supplies are real problems in the community and in the county. Where the farmers are getting a fair price for their products, as compared with the prices at which buyers are passing them on into the trade, or in cases where merchants are dealing fairly with farmers in selling them supplies at cost, plus a reasonable profit, it is altogether probable that cooperative enterprises among farmers may not be able to improve existing methods of doing business. But there are some distinct and definite

business improvements which can be and often are brought about by cooperative enterprise, and which should be considered. Where cooperative effort among farmers will bring a definite improvement in the methods of doing business, and especially where the improvement produces a marked change in the price received by the farmer for his products, or the price paid by him for supplies, the cooperative effort is certainly warranted. In the following cases cooperation among farmers often improves the business methods, and, therefore, demonstrations in marketing and purchasing are warranted under these circumstances.

(1) Cooperative purchasing is generally done on a cash basis, in wholesale lots, and under such circumstances is an improvement over making purchases at retail prices on credit. Local dealers and merchants are often willing to furnish supplies to farmers at wholesale prices for cash on very close margins. Under such circumstances farmers' organizations will find it advantageous to deal through such local merchants.

(2) The sale of farm products in small lots to local buyers is generally done without grading and without any effort at standardization and without ever focusing any attention upon community standard or quality of the product. Cooperative marketing introduces means of proper grading and standardization and does focus the attention upon the quality of the product. Where products are produced without cooperative effort there is no opportunity to reach back into the problems of production and no preparation for a better profit through better methods of marketing. Experience shows that cooperative production, standardization, grading, and marketing generally improve the ordinary haphazard production and marketing.

(3) Farmers in some sections find difficulty in marketing their products, especially in disposing of them through local dealers. The spread between the price paid the farmer and the price received by the buyer may be abnormally large or even beyond all reason, as it is in some cases. Under such circumstances cooperative marketing and shipping of farm products constitute about the only solution of the problem.

Cooperative marketing and purchasing, then, are the best methods to be instituted, through demonstrations, where and

when there is a need for a better system of business to supplant a poorer system.

#### SOME EXAMPLES.

The object of this paper is to give a few specific examples of demonstrations in marketing and purchasing by county agents in the South, and to illustrate the difficulty of the task, with some explanation of the methods actually undertaken in the field.

#### PROVINCE OF SPECIALISTS.

The paper deals exclusively with the acts of the county agents, but the writer desires to set down here as a general principle that demonstrations in marketing and purchasing should not be undertaken by county agents without consulting with marketing specialists of the extension service.

#### MISSISSIPPI.

Cooperative marketing has had more attention from county agents in Mississippi than in any other Southern State, for the simple reason that marketing became the most important problem in that State. From the year 1910 to 1916 or 1917 the State underwent a rather important agricultural revolution. The acreage in cotton decreased 15.9 per cent, and the production of corn increased 42.6 per cent. The acreage and production of oats increased 150 per cent, and hay increased more than 200 per cent. Alfalfa, soy beans, cowpeas, and other forage crops were increased greatly. Lands thrown out of cultivation in some sections produced grass for the grazing of cattle. The increases in live stock from the 1910 census to January 1, 1919, were: Dairy cattle 27.7 per cent, other cattle 21.4 per cent, swine 76.6 per cent. There was also a great increase in sorghum, sweet potatoes, and other minor crops. The marketing of cotton was a well established and well-understood business, but the farmers of Mississippi found great difficulty in marketing these new farm products.

#### PRENTISS COUNTY.

In Prentiss County no cooperative marketing was done prior to the present organization. Buyers of farm products

purchased at their own price, and this was generally 25 per cent below the market value. Under such circumstances there was little inducement for farmers to diversify and to grow other crops for marketing. The county agent began to talk with the farmers regarding cooperative marketing in the fall of 1917. The farmers were hard to convince. Talk would not bring results; the situation required action. They had never had any experience and did not understand cooperative shipments.

By hard work the county agent got a number of farmers to load a car of corn, each farmer's contribution being weighed separately and the records kept by one of the banks. The price received was about 25 cents per bushel above local prices. The local price advanced immediately 25 cents a bushel. The cooperative shipments of corn were continued, but almost without any responsible organization. Farmers seemed to realize that by this method prices were being sustained at a higher figure. This experience led to an experiment in shipping a carload of hogs, with such marked success that the farmers were aroused to greater interest. All of this time there was a very loose and incomplete organization; in fact, the farmers might be said merely to organize for each shipment. As they had experience after experience in the new work the necessity of organization became apparent, and the Farmers' Cooperative Association of Prentiss County, Miss., was organized, with a complete corps of officers, a board of directors, and a regular marketing agent employed. The county agent is in no way officially connected with the organization. He often meets with the board of directors and advises and counsels with the officers of the association. This organization has had a volume of business during the last 12 months of more than \$250,000. One farmer instances bringing some hogs into town and being offered 11½ cents by a local buyer. He put them into one of the cooperative shipments and received 17½ cents for them. The merchants say that if this cooperative marketing were taken away from the farmers of that county there would almost be a revolution, such is its popularity. The merchants, bankers, and others are equally attached to the new plan. One farmer says that corn advanced on the local markets 20 cents, sorghum sirup 22½ cents a gallon, and hogs

from 2 to 4 cents per pound. From August, 1917, to August, 1919, bank deposits in one bank in this county increased from \$148,000 to \$317,000, and in another bank from \$221,000 in August, 1917, to \$482,000 in 1919.

This is a good example of a demonstration in marketing which began under great difficulties and gradually rounded out into a good organization.

#### LAFAYETTE COUNTY.

In Lafayette County the county agent found practically the same situation regarding the local prices of commodities other than cotton and took up the problem of demonstrations in cooperative marketing as early as December, 1916. The object of the demonstration was to show farmers that the existing system of marketing was inadequate and was one of the reasons why a better diversified system of farming had not taken a stronger hold in the county. In December, 1916, the county agent arranged for a cooperative shipment of hogs. There was no organization and little responsibility on the part of the farmers, but the car of hogs brought the best price ever secured up to that time by the farmers of the county, and general satisfaction was expressed by all those concerned. Many shipments, the total value of which ran up to \$75,000, were made under this haphazard and incomplete plan during the year 1917. The banks generally transacted the actual business, though the county agent in many cases did a great deal of the work himself. In each instance, such organization as existed was loose and indefinite, and little responsibility for determination of business policy and the like was undertaken by the farmers or any representative of the farmers, except in individual cases. The better prices had a marked effect.

As often happens, inevitably there came a time when business difficulties arose. Claims came back on shipments, refunds were demanded, and all concerned were convinced that the only solution was a definite organization founded upon good business principles, with thorough individual and cooperative responsibility. Early in 1918 an organization was formed known as the Farmers' Cooperative Marketing Association, with a constitution and by-laws, and arrangement was made for employment of a marketing agent and for a

marketing committee. The secretary of the association was paid a salary of \$100 per month to act as marketing agent. This salary was secured by deducting 1 per cent from the proceeds of hog shipments and 2 per cent from the proceeds of all other products. The fund thus secured was known as the "operating fund." During 1918 products worth \$165,000 were shipped by the association; from January 1, 1919, to July 1, 1919, \$224,000 worth. All hogs and other products are carefully graded before shipment. People of the county generally, and especially those belonging to the association, are greatly interested in and pleased with this organization. Bank deposits in the county increased from August, 1916, to August, 1919, from \$310,000 to \$911,000.

As a whole this is a good demonstration of progress from no marketing organization among farmers to one which assumed responsibility for all the business. The education of the farmer and progress toward a responsible organization were somewhat slow, but the result seems to have been obtained gradually and quite surely.

#### WINSTON COUNTY.

The progress in Winston County is interesting. Prior to the fall of 1916 no attempt at solving the marketing problem had been made. Cotton, of course, had a ready market. All other farm products were sold by the farmers individually to dealers, when they could persuade such dealers to buy. Cattle and hogs were bought at the dealer's own price. A carload of hogs had never been shipped out of the county. Ten hogs would glut the local market. Generally farmers were not growing hogs in excess of their own individual needs. Butchers in one of the principal towns of the county in the spring of 1916 were paying farmers 8 cents a pound for corn-fed hogs, killed, dressed, with heads and feet cut off. There had never been any cooperation among the farmers in this county, other than in the Noxapeter community. There an organization had been perfected during one season to grow and market a cabbage crop, resulting in a disastrous loss to the farmers, due to lack of wisdom in the entire plan. During the summer of 1916 the county agent asked the specialist in marketing of the State extension service to come to the county and talk on the subject of organization and



cooperative marketing. One of the specialists then assisted the county agent in the organization of six farmers' clubs. Men joined these clubs and put hogs on feed for future marketing. The first cooperative shipment of hogs resulted in such a great increase over prevailing local prices that the cooperative hog marketing business was relatively easy thereafter. In 1917 a county advisory board composed of members of the board of supervisors and four farmers from each district of the county was appointed for the purpose of assisting the county agent in his work. This organization, working with the farmers' clubs, has appointed a marketing committee which handles all of the marketing business transacted by the organization. The organization now in existence is called the Winston County Farmers' Market Association. From October, 1917, to October, 1918, this association marketed \$92,553 worth of farm products, and bought \$10,000 worth of fertilizers and seeds cooperatively. Up to August 1, 1919, they had marketed \$68,300 worth of farm products and purchased seeds and fertilizer valued at \$38,000.

This demonstration is a good one, though the organization has probably not reached the full stage of entire responsibility most desirable in such cases.

The deposits in the banks of Louisville increased from December, 1916, to December, 1918, from \$376,663 to \$581,183. Farmers and business men all seem delighted with the improved conditions brought about by this marketing enterprise.

These few examples are given to show the kind of work going on in Mississippi. Practically every county agent in the State is putting on some marketing demonstrations. In 1918 the total value of products shipped by farmers' organizations formed for demonstrations in marketing was \$3,396,183.

#### ALABAMA.

Alabama has undergone the same changes as Mississippi. The number of hogs, cattle, and dairy cows has increased in about the same proportion. There has been a distinct change in acreage, especially in the southern counties, where the cotton acreage and production has greatly decreased and the acreage and production of other crops increased accordingly.

In this State demonstrations in marketing have mainly been the arranging for "sales days." These sales days have been arranged for the selling of crops and live stock where the marketing problem became difficult, especially where the prices, under the existing system of marketing, were inadequate. For example, in 1918 a large acreage in Harrison County was planted to peanuts. When this crop was harvested and offered for market there was practically no demand for peanuts, and a number of farmers sacrificed their crops at relatively low prices, ranging from \$80 to \$90 per ton. They sought the county agent for relief. In March the county agent, in cooperation with the marketing specialist of the extension service, got in touch with buyers who were in the market for peanuts for the confectionery trade and for milling purposes. These buyers agreed to settle for peanuts bought from farmers on grades and weights established at the time of purchase. The county agent and the extension specialist assisted the farmers in grading. During the week ending April 5, 125 tons of peanuts were shipped out of the county at \$110 per ton, f. o. b. cars. During the next week 11 cars were shipped out on the same basis. The total sales for this week amounted to \$26,000. It is estimated that the saving to the farmers in these shipments was \$5,000. No definite cooperative organization was established for making these sales, but the farmers were enabled to dispose of their crops to better advantage through arrangements perfected by the extension service without the extension service finding it necessary to transact any of the business. The result was to demonstrate to farmers the advantages of a better system of marketing.

In south Alabama great attention has been paid to cooperative sales days for the sale and shipment of hogs. Prior to the establishment of this plan there was very little system in the sale of hogs and the prevailing prices were several cents lower than prices paid at larger points. The main difficulty was the small farmer who had much less than a carload lot, usually from 1 to 5 head. The county agent and the extension specialist in marketing arranged for sales days. The associations organized are composed of farmers who organize for the purpose of selling hogs on these sales days or shipping them direct to market as a cooperative shipment. The

farmers pay for the scales, and where pens are provided the farmers build and pay for the pens. They also pay for weighing and grading. A charge of 5 cents per head is made for weighing and there is a membership fee in the association of \$1. This money is generally paid for the scales and the pens. Thus far the county agent has generally cooperated with the associations in helping them fix the dates of shipment and has brought them the news service regarding market prices of hogs at central markets. On the sales days the hogs are weighed and graded and are then offered for sale, the association reserving the right to reject any bids. Notice of sales was given to local and packer buyers. If the bids are not satisfactory, the association proceeds to ship the hogs to the most advantageous market. The shipment is generally made in the name of a local bank and the returns are received by the bank and divided according to prearranged plans, the checks being mailed by the bank to the farmers interested.

The result has been that the farmers are not only able to get market prices for their hogs, but the buyers operating in that territory have had to pay close to the market price in order to handle hogs. Quite a number of these county associations have reached the stage where they operate without any assistance from the county agents.

#### LIMESTONE COUNTY.

The present county agent in Limestone County began work in September, 1914. At that time there were few hogs in the county and most of the meat consumed was shipped in. Ravages of hog cholera had practically wiped out the hog business of that county in 1913-14. The county agent spent the greater part of his time in 1914-15 in demonstrating the use of the antihog-cholera serum and in convincing farmers that by its use they could produce hogs profitably. In March, 1916, the county agent organized the first community better-farming association and during the balance of that year organized nine others. Each of these community organizations had an exhibit at the county fair. Six of them bought breeding stock cooperatively, five of the Duroc-Jersey breed and one Poland-China. The county agent

worked his boys' clubs through these associations and used the boys' club work in helping to introduce a better breed of hogs. Bankers assisted in financing the enterprise. One of these associations won the State first prize awarded by the Duroc Association for exhibiting registered Duroc hogs in 1917-18.

During these two years there was no surplus of hogs to be shipped out of the county, hence the marketing problem was not uppermost, but in 1919 this problem became critical. A county-wide association, known as the Better Farming Association, in which all of the clubs were affiliated, was organized in March, 1919. This association was quite similar to the farm bureaus in Northern States. Through community organizations the farmers shipped cooperatively 20 carloads of hogs during the year. At the first shipment in 1919, 70 per cent of the hogs were graded as No. 1. These hogs netted 18 cents a pound, or 4 cents more than the local buyers had been paying. The county agent is active in assisting the farmers in their demonstrations. They have been inexperienced in organization and the county agent has done more work than might otherwise be necessary, but the farmers are rapidly assuming responsibility, and as the marketing committee and the business manager assume greater responsibility the county agent will need to pay but little further attention to this enterprise. In this demonstration there was good organization for educational purposes, but the demonstration has rounded out into complete business responsibility rather slowly, mainly due to local circumstances.

Examples in Alabama could be multiplied, but these are sufficient to illustrate the working out of the general plan for demonstrations in cooperative marketing. Every county agent in the State is doing some work along this line.

#### TEXAS.

##### HENDERSON COUNTY FARMERS' COOPERATIVE SOCIETY.

In 1916-17 the county agent of Henderson County and the specialists in horticulture of the extension staff at the agricultural college put on a series of demonstrations throughout the county in pruning and spraying peach orchards. The growers who sprayed and cared for their fruit

received little encouragement from buyers in 1917. Although they had a better grade of fruit, they enjoyed no preference over "orchard run." The buyers said there was no market for fruit. They took it at prices ranging from 50 cents to a dollar a bushel. In the winter of 1917-18, after conducting a spraying demonstration on one of the farms in question, the subject of marketing was brought up, and the farmers announced that if they did not get better prices they would abandon their orchards and go out of business. Eighteen men were present at this demonstration. They organized the Henderson County Farmers' Cooperative Society, but the first real meeting for thorough organization of the business was held in June, 1918, with 46 men present. The business was actually begun that year with more than 100 paid-up members. A board of directors was appointed to handle the business of the society and a sales manager was paid a salary for handling the active business. The county agent assisted in this organization but did not have any official connection with it. He and the specialists of the extension staff gave the association every possible assistance regarding business management, grading, packing, marketing, accounting, and the like. During the season of 1918 this association sold 33 cars of peaches and 36 cars of melons and purchased 4 cars of oats, 2 cars of alfalfa, 1 car of cotton seed, 2 cars of peach baskets, and 1 car of fertilizer. They averaged from 50 to 75 cents a bushel more for their peaches than was received by other farmers in the local markets. Watermelons sold at \$75 a car more than local buyers were willing to pay. The total turnover of the society during the year 1918 was approximately \$125,000. In 1919 they shipped 144 carloads of peaches valued at something over \$112,000. The record of their shipments of other products has not been received. This organization has a very competent manager, and has adopted a broad policy which is bringing all of the farmers in the county into a fine cooperative organization. This was a well-managed and effective demonstration.

#### LIBERTY COUNTY EGG CIRCLE.

In Liberty County the county agent found the farmers' wives having very great difficulty in the marketing of eggs,

especially in the summer. The price was exceedingly low and the quality inferior. Believing this to be an important problem, he encouraged a group of farm women to organize the Dayton Egg Circle. These women were organized into an association with a secretary-treasurer, who was also the business manager. They adopted a standard trade-mark. Each egg was stamped with the number of the member as well as the trade-mark, and arrangements were provided on each farm for producing infertile eggs. Each member agreed to gather the eggs twice daily and follow instructions regarding the care and marketing of them. The association had 12 members to begin with and they had difficulty in getting two cases of eggs a week. From July 15, 1915, to the same date in 1916, the total shipments were 9,870 dozen, bringing in \$2,185, which was distributed among the members. From June, 1917, to June, 1918, they shipped 13,830 dozen. At that time they had 28 members. From June, 1918, to June, 1919, they shipped 29,377 dozen, bringing in \$8,975.91. Since the first demonstration the county agent and specialists have not found it necessary to devote any particular amount of time to assisting this organization. It is an excellent example of a good marketing demonstration.

#### WILLIAMSON COUNTY.

Two excellent pieces of work done in Williamson County are worthy of mention as good demonstrations.

#### COOPERATIVE SALE OF WOOL.

In quite a number of counties in west Texas sheep and goat raising is important, but the county agents found it suffering because of lack of system in marketing. The wool of that territory was generally bought in small lots by local buyers at prices much below prevailing market prices, as was shown by this demonstration. The result was to discourage production. In 1918, for example, the county agent in Williamson County, assisted by the specialist in sheep production of the extension service, organized the Williamson County Sheep and Goat Breeders' Association, the objects of which were, first, advancement of education along lines of feeding, breeding, and management; second, cooperative marketing of lambs, fat sheep, and breeding stock; third,

cooperative marketing of wool and mohair; fourth, buying of breeding stock and cooperative use of valuable rams. The membership of the organization in Williamson County decided to market their mohair cooperatively, and approximately 48,600 pounds of wool and 4,500 pounds of mohair were gathered in a public warehouse in Georgetown and a special sales committee was appointed by the executive committee of the association to receive bids from local dealers. All such bids were turned down because of the knowledge gained by the association of prevailing market prices elsewhere. One local buyer called up over 30 of the local growers of the county, trying to buy their wool separately from the association. This wool was sold by the association to a Boston firm at an average price of  $65\frac{3}{4}$  cents a pound, while local dealers offered an average price of 50 cents. The mohair sold for 77 cents a pound, while local buyers made no bid on mohair at all. This is an excellent demonstration of good organization and good marketing business. Thirteen such organizations were perfected in Texas in 1918, and over 650,000 pounds of wool were handled by these associations at an estimated increased profit of \$60,000 above local dealers' prices.

#### EMERGENCY PURCHASE OF FEED.

The year 1918 was the culmination of three years of disastrous drought conditions in Texas. The amount of feed produced in the State, especially in the central and western portions, was totally inadequate for local needs. Local prices were abnormally high and it became necessary for the Government to establish a market news service to assist farmers in that territory in locating supplies of feed. Wherever possible, local dealers handled the business for local groups of farmers.

What was done in Williamson County is a fair sample of what was done in many other counties. The county agent simply furnished the Government news service for the benefit of the farmers of the county. There were in Williamson County quite a number of community organizations of farmers working with the county agent in a manner similar to groups of farmers in Northern community organizations under the farm bureau system. These groups were dealing

with educational problems in the main by using their secretaries and with the advice of the county agent transacting the business through local banks or through local feed dealers where such feed dealers were willing to handle the business of such groups of farmers on the basis of the cost plus a reasonable commission for transacting the business. This was the plan of doing business. In this manner something over 200 carloads of feed were brought into the county for the purpose of sustaining live stock on the farms. In addition 16 carloads of planting seed were also bought cooperatively by these associations. The county agent did not transact any of the business of these concerns, but simply put them in touch with the market news service and with banks. The market news service gave them information regarding the location of carloads of feed of various kinds which could be bought and the prices asked for the same f. o. b. point of origin. The business was transacted between the local banks and the banks at point of origin, except where circumstances made it possible to use dealers at both ends of the line. The saving in corn was from 5 to 15 cents per bushel, cottonseed meal 15 cents a sack, oats 15 cents a bushel, and the average saving in hay \$4 a ton.

It is true that this demonstration was possibly somewhat temporary in its character, and yet the education and experience gained by the farmers over a large territory in west Texas through these cooperative purchasing efforts in 1918 left them much better prepared than ever before to deal with their ordinary business affairs. The experience gained in a somewhat loose organization for a temporary purpose is reflected in a general increase of better grading, better marketing, and better methods of purchasing supplies.

This emergency work was done in quite a large number of counties, in many of which local grain dealers rendered important service by selling on a wholesale basis plus a small profit to groups of farmers who were trying to meet the peculiar emergency which they were facing. The total number of carloads of feed purchased in this manner in Texas ran up to 4,871, and the total saving, including a half-rate on freight conceded to them by the Railroad Administration, was approximately \$785,543.



These few illustrations have been given merely as examples of a large amount of work of county agents in the Southern States in dealing with the difficult problems of marketing and purchasing. The most important lesson to be gathered from these examples and from a study of all the experiences of county agents in the South in the last 10 years is that responsible and efficient organization and management are necessary to the success of all such activities. Some county agents seem to think it possible to do marketing without organization, but experience shows that, sooner or later, the absolute business necessity of a responsible organization becomes apparent and the entire effort fails unless this is provided. Experience also shows that education and demonstration make organization possible. A responsible organization is the key to a good demonstration in marketing or purchasing.

The total value of products sold or purchased in marketing and purchasing demonstrations, in which was included the annual turnover of organizations of farmers fostered and encouraged by county agents during the year 1918 for the purpose of purchasing supplies or marketing farm products, was as follows:

Purchase of fertilizers, lime, etc., amounting to 64,382 tons, valued at \$1,906,122, exclusive of nitrate of soda, handled by county agents under war provisions in the Department of Agriculture; cattle marketed in cooperative shipments valued at \$1,340,294; swine marketed in cooperative shipments, \$2,749,948; corn, wheat, and other grain marketed, 1,395,960 bushels, valued at \$1,590,448; miscellaneous agricultural products marketed, valued at \$2,631,985. The grand total of the value of the marketing and purchasing effort of organizations fostered by county agents and put on at first as demonstrations, from figures made on the annual turnover of such organizations following such official demonstrations, was \$17,156,232 for the year 1918. It is estimated that the saving to farmers averaged 16 per cent, or approximately \$2,834,067.

# ELECTRIC LIGHT AND POWER *in the* FARM HOME

By A. M. DANIELS,

*Assistant Mechanical Engineer, Division of Rural Engineering,  
Bureau of Public Roads.*

## ECONOMIC VALUE OF ELECTRICITY.

**E**LECTRIC light and power in farm homes not only removes drudgery but saves time and money as well. The time required to operate the churn, the separator, and the washing machine, and to do the ironing, the cleaning with the vacuum cleaner, and the pumping of water has been reduced materially in many cases. More time is made available for other things and not infrequently it has been possible to reduce the amount of hired help.

An inquiry by one firm to obtain the opinion of users of electricity on the farm and in the home regarding saving in time and money brought reports from a total of 67 persons. Their average total saving by the use of electricity was 20½ hours per week for all uses. This really should be higher, since comparatively few included the saving in time due to the elimination of the cleaning of lamps. An average of 2¾ hours per week was shown as saved on churning; 3.83 hours per week on operating the separator; 4.46 hours per week by not having lamps and chimneys to clean; 3.52 hours per week on using the washing machine; 2.76 hours per week on doing the ironing; 10.31 hours per week on pumping water; and 6.32 hours per week saved on other applications of electricity. The average estimated value of the time saved was \$33.80 per month. This was realized by the employment of less hired help in some instances; in others by the release of labor for other work, while in some cases the value of the time saved was estimated at from 20 to 40 cents per hour.

To-day as never before is the need of labor-saving devices in the home being felt. The servant problem is rapidly be-

coming more serious. The increasing wages of household servants and washerwomen are approaching a point which the family of average means can not meet. Through electricity, the tireless servant, is perhaps to be found the solution. Washing and ironing machines for household use, electric dishwashers, vacuum cleaners, toasters, ranges, and the whole series of electrical household specialties for use in the city and in farm homes where electricity is available certainly have brought relief to many and are only waiting to be called upon by many others.

Comparatively few of our farm homes to-day have electricity available. The number, however, is increasing rapidly, owing principally to the advent of the farm lighting and small power plant. In addition to this means of supply, some farm homes are so situated that electricity can be obtained from high-power transmission lines that pass within a reasonable distance; others are near streams of water which may be developed as sources of energy for farm or community hydroelectric plants; while in some localities successful windmill electric generating plants have been the means of supply. In the Yearbook for 1918 (Separate 770), directions are given for conducting preliminary surveys to determine the possibilities of a particular stream.

Where farm homes are supplied with electricity from transmission lines, central stations, or farm hydroelectric plants taking current directly from the generator, it is usually supplied at 110 to 115 volts. Windmill electric plants may be of this voltage, but on account of the relatively high battery investment they are more likely to be of the 30 to 32 volt type. The engine-driven farm lighting and power plants, which are multiplying rapidly at present, are mostly of the 32-volt type; many of the companies supply these plants operating at 110 volts also.

#### USES.

The uses for electricity, or the tasks to which it can be applied about the farm home, are almost unlimited. The man who may install it primarily for lighting will soon find himself applying it to other tasks, and as he begins to see what it can do for him and the multiplicity of its usefulness

becomes apparent he will realize how electricity is each day lessening his labors and making this old world a happier and better place in which to live.

The first thought of electricity is usually for lighting, and this is not improper. But it should not be overlooked as a source of power. It was not so long ago that, with the exception of water power and the steam engine for the heavier work, the farm was without motive power and thus hand labor was not eliminated on the farm as it was in the



Milking by Electricity.

Electrically operated milking machines have been responsible for a saving in hired help equivalent to \$50 and more per month.

city and in the industrial world. In recent years great strides have been made. Mechanical milking is now a reality and with it a reduction in hired help.

The utility motor adapts itself wonderfully well to a number of uses, thus saving the expense of installing a separate motor for each job. Several types are available. Sometimes a support rod is attached to the motor base to steady it when in operation. This is a desirable asset.

Then there are the many tasks of the kitchen where a little motor can do in but a fraction of the time consumed

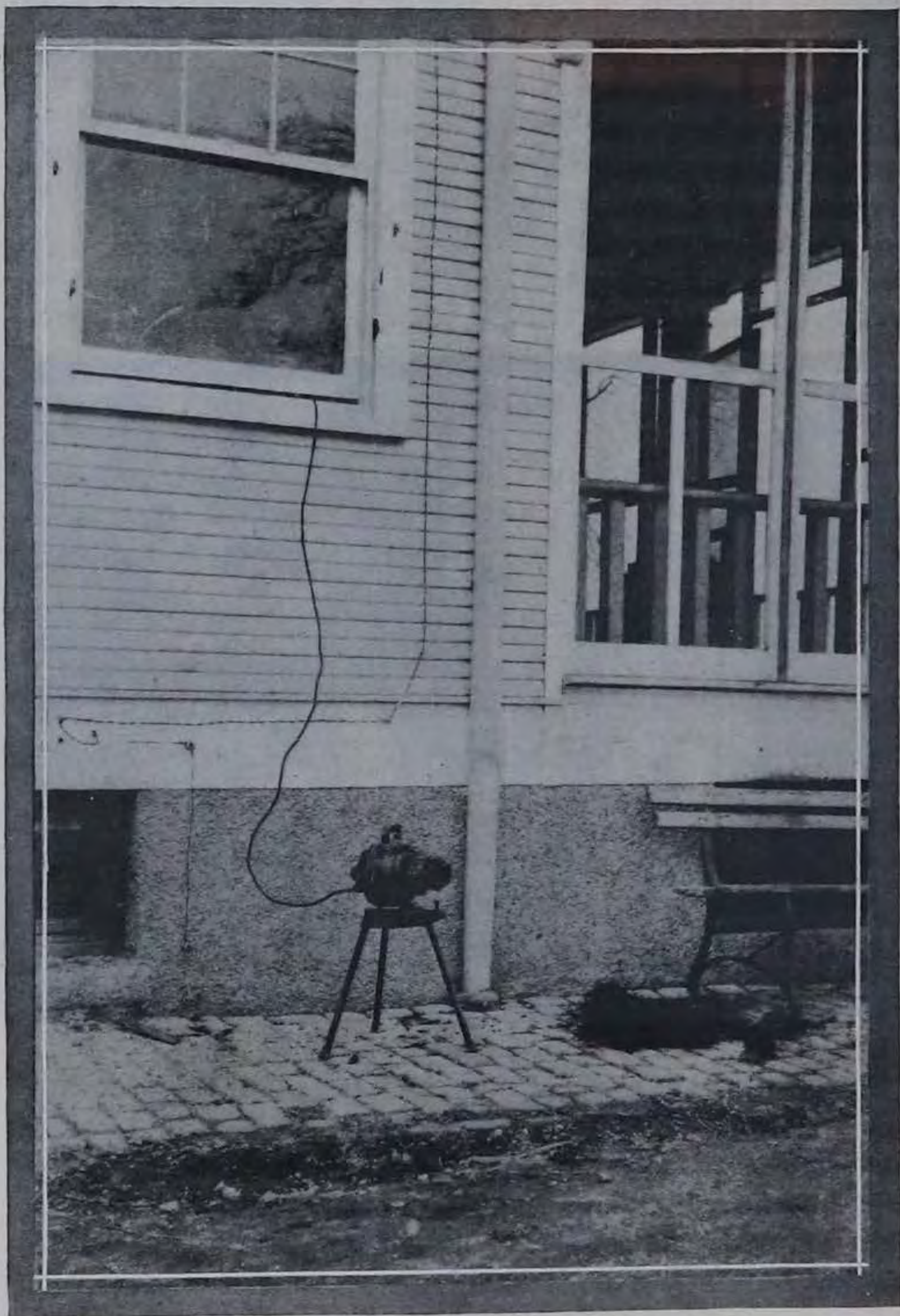

Portable Utility Motor.

Capable of being carried about from place to place, a portable motor with stand serves to reduce the time required to complete many jobs and saves the expense of providing a different motor for the separator, churn, fannig mill, grindstone, washing machine, and many other kinds of apparatus.

by hand work, jobs that, though not particularly tiresome, are nevertheless irksome; such as grinding meat and coffee, stuffing sausage, mixing bread, or sharpening knives.

The electric range will be better appreciated as its advantages become better known and will be used where electric plants of sufficient size to operate a range are available. Many heating units such as table utensils, fireless cookers, water heaters, griddles, and others, are already in use and are proving themselves to be desirable under different conditions. The washing machine, electric iron, vacuum cleaner, sewing machine motor, and motor-driven pumping units are all helping to make life on the farm more enjoyable and appreciated.

#### LIGHTING.

Lighting probably is the influencing factor in a decision to have electricity available in the farm home; therefore it usually will be considered first.

But before any definite steps are taken toward purchasing electricity from a central station or high-tension transmission line, or installing a private farm hydroelectric plant or an engine-driven plant, it is advisable to make an estimate of the average daily load.

If it is assumed that in the list below the distribution of lamps and the time that they will be burned is a fair average



Motor-Driven Sewing Machine.

The machine is mounted on a wood base and may be placed on any table for use. A foot-operated switch permits starting and stopping readily

for conditions prevailing on the average farm, then the following represents an electrical load for one day on that farm.

*Estimate of daily lighting load.*

Location.	Lamps.		Hours per day.	Total watt-hours.
	Number.	Watts.		
Living room .....	2	40	3	240
Dining room .....	2	20	2	80
Kitchen.....	1	20	3	60
Bedrooms (3 bedrooms).....	1	20	$\frac{1}{2}$	30
Barns.....	8	20	2	320
Other outbuildings.....	4	20	$\frac{1}{2}$	40
Miscellaneous, porch, yards, etc.....				100
Total average lighting load per day.....				870

With this schedule before him the farmer is in a position to interpret his needs for lighting more intelligently.

#### WIRING PLANS FOR THE HOME.

In building or purchasing a home it is desirable to incorporate in its construction or furnishings all such features as will insure maximum comfort and convenience. Electricity aids materially in supplying these features, particularly if care and thought are given to laying out the system.

It is no doubt true that many builders of homes delay the wiring of their houses until after they are built. Probably this tendency is more pronounced in rural districts than in cities. This may be because they are not quite convinced that electrical devices will supply the comforts and conveniences attributed to them. Or perhaps they may be under the impression that a haphazard system of wiring that can be installed cheaply with no provision for the future needs will be just as satisfactory. Sooner or later this will give reason for complaint. Especially will this be the case where electric lights and heating devices are used on the same outlets. To be obliged to unscrew a lamp from a socket, screw in a plug for a heating device, and when through using it, unscrew the plug and replace the lamp will offset much of the convenience which the electric heating unit offers. Perhaps no better example could be mentioned than the necessity of using the baby milk warmer at night in a room equipped with but one electric light.

Where it is intended to use electricity for lighting and for various devices for heating and cooking, the arrange-

ment of the electric circuits should be carefully considered.

The wiring of houses for electric heating devices can be classed under three general plans. They differ princi-



A

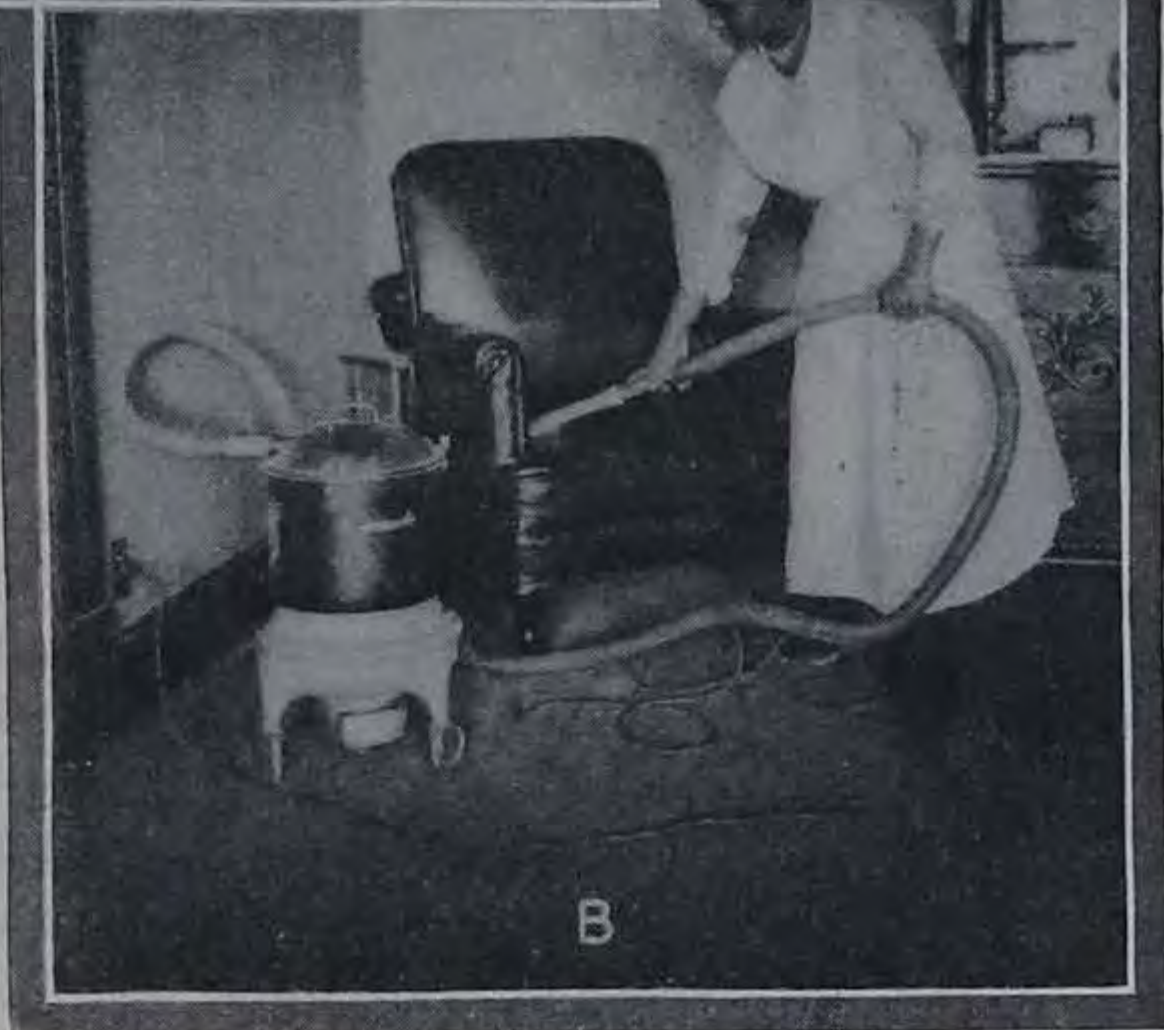

B

pally in cost of installation. The first plan is the most complete. It comprises separate heater circuits to the different rooms, all radiating from a single location and measured in another meter than that used for

lighting. This system is the most expensive and is applicable principally to those houses for which electric current is pur-

#### The Vacuum Cleaner.

These machines are obtainable in various styles. A. The bag type. As shown it is equipped for carpet cleaning. Attachments enable it to be used for other cleaning operations. B. The cylinder type. As shown it is equipped for furniture cleaning.



chased from a high-tension transmission line or central station company. The second plan combines the use of lighting circuits and a separately metered, heavier wired circuit from which current can be drawn for the operation of at least the larger cooking utensils. This system also generally presupposes the purchase of current, but is also applicable to such houses as may be supplied from farm hydroelectric plants. The third system is the simplest and comes nearest to being in almost universal favor. It makes use of lighting circuits provided with proper outlets at various points throughout the house. It is the only one which may be considered in connection with a low-voltage (32-volt) storage battery plant and also with many of the 110-volt outfits.

#### SWITCHES.

A liberal use of switches in a home is recommended, as it invites economy by encouraging the putting out of lights when leaving a room. The flush type placed in metal cut-out boxes sunk in the wall are largely used. They are very satisfactory and should generally be located just inside of entrance doors. For large rooms it is well to have more than one switch and sometimes it is desirable to use a switch one turn of the handle of which lights one group of lights, the second, an additional group without putting out the first group, and the third turn puts all out.

#### HALL LIGHTS.

It is customary to arrange lights for halls and stairs so that they may be turned on or off from one or more switches, usually two, one on the first floor and one on the second floor. These switches are known as 3-way or 4-way, or 3-pole or 4-pole, switches. Thus a person on a lighted first floor wishing to go to a dark second floor is enabled to light the second-floor light from the first floor, go upstairs and from there extinguish the first-floor light.

#### CLOSET LIGHTS.

A ceiling light placed in a closet is very desirable, especially if the light from a window does not enter it. Switches for closets are often set in the door joints and operated by the movement of the door. If, however, the door is to be left open for ventilation, wall switches are



of the switch, as is not infrequently the case of cellar lights controlled from the first floor, a pilot light switch that contains a small pilot light which burns when the switch is on serves to economize current. This type of switch is to be recommended in

preferred, for otherwise it would be necessary to unscrew the lamp from its socket.

#### PILOT SWITCHES.

For a switch to operate a light which is not visible from the location



Drop Shower and Wall Switch.

Lighting fixtures of this type frequently produce pleasing effects, although the inverted dome (not shown) is preferred by many. *B.* Wall (flush type) push switches are usually placed about 3 feet 10 inches from the floor. When desired they may be placed higher so as to be out of reach of small children.

connection with all heating or other appliances which are fixed in position and do not visibly indicate when current is on. Switches of this type are obtainable as combination units which may be placed together in the same wall outlet and covered with a single plate.

#### BASE AND WALL RECEPTACLES.

A liberal distribution of flush receptacles and plugs throughout a residence will be found handy for a great variety of purposes. When wiring is being done the installation of a few for which at the moment no use appears will cost but little more and the chances are that as the advantages of electricity become better known they will be found very desirable. Such receptacles may be placed generally on or just above the baseboard and the plates may be painted to match the surroundings so that they will be inconspicuous. It is well to install two spare receptacles in each main room and hall.

#### OUTSIDE OUTLETS.

The porch should have one or more outlets in the ceiling and if a living porch is provided receptacles should be placed in the side wall 12 to 15 inches above the floor (to prevent water splashing on them), to which may be connected a reading lamp, chafing dish, or such other useful electrical device as may be needed. The lights in the ceiling should be controlled by a switch just inside the door or if it may be desirable to turn them on or off from the outside as well, a double switch (on inside and outside) can be used.

#### FLOOR RECEPTACLES.

The use of heating devices on the table calls for floor outlets to avoid a wire dangling from the lighting fixture above. Floor boxes with cone-shaped tops projecting above the floor to prevent water from entering the box and to protect the wires are obtainable, or the cone tops can be removed and a flush top substituted.

#### CELLAR LIGHTING.

Outlets in the cellar should be so located as to best illuminate laundry appurtenances, furnaces, and fuel storage bins,

and pumps or other apparatus that might need attention. Small consumption lamps, 10 or 15 watt, usually are sufficient for general illumination in the cellar. For a work bench or other utility requiring better light, 40-watt lamps are better. Store rooms for vegetables and other edibles should be well lighted from the ceiling, with a controlling switch at the door or a pendant switch at the lamp. At least one light in the cellar should be located to illuminate the stairway, and this light should be controlled from a switch at the head of the steps.

#### ROOM LIGHTING.

It is a decided mistake to attempt to limit outlets in residences to the fewest possible permissible with the original furniture layout. They should be planned with a view to any rearrangement of furnishings. It is always possible to cap outlets until needed. All portions of a room should be properly illuminated and the lighting layout should be studied with this in view.

#### HALL LIGHTING.

A soft general illumination adapts itself well to halls, with the possible addition of a portable table or standard lamp.

#### PANTRY LIGHTING.

The pantry should be well lighted from a high center outlet so that contents of dressers and cupboards can be seen distinctly. The outlet should be controlled by a switch at the door.

#### KITCHEN LIGHTING.

A ceiling outlet controlled from a switch at the door into the dining room is always recommended. If no other lights are provided there is annoyance from shadows at the stove, at the sink, or other points where one works. For this reason side outlets are advised, particularly at the sink and near the other most-used portion of the room.

#### LAUNDRY.

As the laundry is usually finished in light color, comparatively little general illumination from ceiling fixtures

is required. At the ironing board a drop light should be provided with a socket of the double outlet type, or provision be made for a separate outlet for connecting the electric iron.

#### BATHROOM LIGHTING.

For bathrooms of the size found in most houses, one drop-light from the ceiling or a bracket with the lamp located in front of and slightly above the mirror is usually sufficient. When the room is larger than the average, the installation frequently includes a ceiling outlet with a side outlet placed on each side of the mirror. The ceiling outlet is usually controlled by a switch at the door, while the side outlets may have chain pull or key switches. The side fixtures at the mirror, if installed, should project 8 to 15 inches from the wall and be so placed as to light well each side of the face. Bathroom lights should never be so placed as to throw the shadow of anyone in the room on the window shade.

#### SEWING-ROOM LIGHTING.

The general illumination of the sewing room may be from the ceiling, with one switch control, or, where the room is small, one light, either drop from ceiling or wall outlet, will be sufficient. Though not absolutely essential, side lights installed to brightly illuminate the sewing and cutting table and the location where the comfortable chair for hand sewing is usually placed add conveniences not commonly met. A separate outlet for the pressing iron should not be overlooked, and the need of an electric fan in warm weather may call for another outlet, although in most cases it will be attached to the lighting socket.

#### ELECTRIC COOKING.

The use of electricity for general cooking purposes is really deserving of far more space than can be given in this short article in order to convey properly even a fairly accurate conception of its merits. Among its advantages, and they far outweigh the disadvantages, may be mentioned those that follow.

As compared to other methods of cooking, little heat is thrown into the room. This makes it strongly favored for

hot weather, when the average kitchen is too hot to work in comfortably most of the time that the cooking is going on. Contrary to conditions existing in kitchens where fuel is consumed at the burners of the stove, no products of combustion pass into the air of a room, hence with electric cooking the air is decidedly better when the outside temperature requires that doors and windows be kept closed. The rate of cooking can be more definitely and quickly regulated. Electric cooking utensils are not covered with soot and therefore are easier to wash and clean. If a breeze is blowing through the kitchen on a summer day no attention need be paid to it, as there is no danger of explosion or other trouble due to the possible extinction of the flame. In fact, with electric cooking there is practically no such fire risk as there is with coal, gas, or gasoline. Some cooking can be done on the dining-room table, and this sometimes appeals strongly to those who do not like to absent themselves from the family meal or who like to have things hot from pan to plate.

Electric cooking is no doubt a desirable asset to any household. It must be regarded as more expensive, when dollars and cents are considered, but many who use it rate the convenience and advantages as well worth the difference. Electric cooking, however, can not be considered as possible with the ordinary farm light and power outfit. Service from transmission lines, central stations, and even from some private hydroelectric plants of more than the usual capacity does make it available.

#### SOME LIGHTING-CIRCUIT APPLIANCES.

There are several appliances that can be used on electric lighting circuits. Several types of portable disk stoves are available. They may be obtained for either the 32 or 110 voltage. Bacon and eggs and griddle cakes may be cooked on these stoves. Toast may be made by placing a piece of wire netting between the bread and the top of the stove. They may be used in the dining room, sick room, etc. They are made in at least three sizes, and the largest ones are provided with a three-point switch which permits a regulation of temperature.

The electric toaster permits the toasting to be done where it can be watched without undue inconvenience. Many claim that the sooner toasted bread is served after toasting

the more delicious is its flavor. To be able to toast bread at the table during the meal has much to recommend it to those of

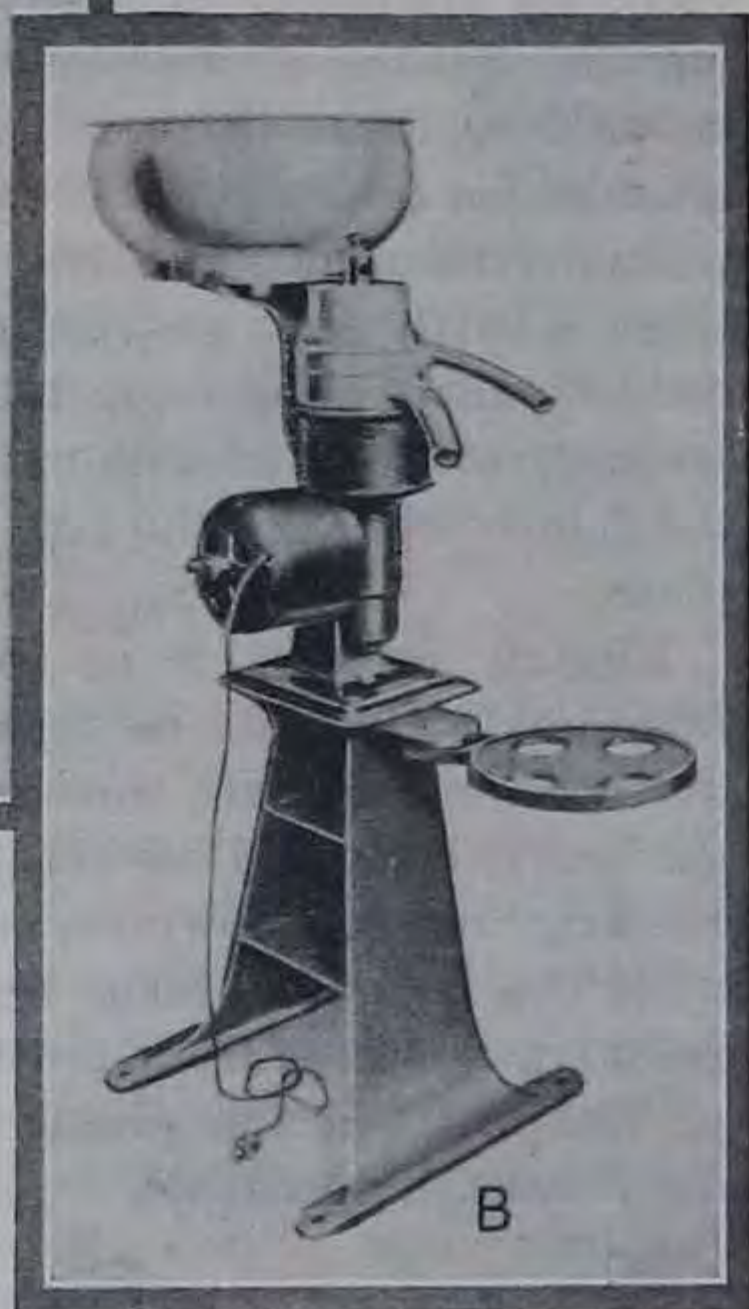

this opinion. These toasters may be obtained for either the 32 or the 110 voltage.

For those who hold that coffee should not be boiled and should be served directly it is made in order to retain the delicate and distinctive aroma which may be lost in the form of vapor, the coffee percolator has much to commend it. They are obtainable in several sizes for both the 32 and the 110 voltage.

Being obtainable in a number of different designs and designed for perfect control and regulation of heat, the electric chafing dish permits the preparation of a small meal in any room where an electric-lighting plug exists. They too are procurable for either the 32 or the 110 voltage.

Labor Savers.

When one can afford to equip each labor-saving device with a separate motor, it is to be desired. A. Motor-driven washing machine and wringer. B. Motor-driven separator.

The hot-water bottle has seen so much use in many homes that some would not care to be without one. The application of heat is recognized by the medical profession as a very important and reliable means of relieving suffering.



The Electric Iron.

Probably the best known and most used of all labor-saving devices. Heated from within by a continuous supply of heat, it avoids the changing of irons over a hot stove and permits a more pleasant room in which to work.

And the electric heating pad eliminates the danger of leaking water and provides or maintains a constant maximum temperature. A regulating switch permits adjustment for different degrees of heat.

For table cooking the table grill fills a long-felt want. With it one may fry, broil, toast, boil, or have a hot plate,



each necessarily limited in capacity but functioning perfectly. The utensil consists of a horizontal series of open radiant coils which glow almost instantly upon turning on the current. A vessel is supplied for boiling water or steaming eggs, the cover of which when inverted forms a frying pan. Under the heating coils is a compartment for broiling, while bread may be toasted on gratings directly over the heating coils.

#### WASHING MACHINE.

The washing machine has perhaps done as much (if not more) toward relieving the housewife of much of the extra burden, which has been thrown upon her under present economic conditions, as any other of the labor-saving devices. There is no doubt that, in a measure, it replaces the washer-woman. Let no one have the impression, though, that it does the family wash and therefore offers a complete solution of the problem. The installation of a washing machine removes much of the drudgery and heavy work of washing, but when the job is once started practically all of one's time is required until the clothes are out on the line. It has thus made it possible for girls 14 years old to do the family wash, whereas under the old manual way it would have been considered that the labor required made that out of the question.

These machines are manufactured by many companies and require comparatively little current for operation. They may be operated from any lighting socket.

#### ELECTRIC IRONS.

Electric irons are available in weights of 3, 4, 5, and 6 pounds. The lightest consumes about 350 watts, the heaviest about 580. The 4-pound iron probably is the most used. The electric iron is the most popular of all the household conveniences. It is manufactured in several shapes. In one, a pull-off plug makes the electrical connection to the heating element of the iron. In another, an indicating "on and off" switch is added, while in still another a permanently attached cord is provided. One type can not be recommended above the other two.

# FEDERAL SUPERVISION OF LIVE STOCK MARKETS



By LOUIS D. HALL,

*Specialist in Charge, Marketing Live Stock and Meats  
Bureau of Markets.*

UNIQUE among the marketing systems of the world, the stockyards centers of the United States are the most highly organized institutions in existence for the sale of live stock and for the manufacture and distribution of live-stock products. Contrasted with the village market place, where the farmer dickers directly with the butcher over the price of his pig or cow, the mammoth modern live-stock markets of America have become the wonder of the world. The Chicago stockyards, foremost in volume of business among all markets of any kind, draw their supplies of animals from the most remote coasts and corners of the country, and transact annual live-stock sales of about a billion dollars, or more than three millions a day. Kansas City, Omaha, St. Joseph, East St. Louis, Fort Worth, St. Paul, Sioux City, Denver, and other important points likewise have developed to the degree of great public centers of interstate live-stock trade. In all there are now about 70 public markets to which live-stock shipments are consigned regularly.<sup>1</sup> During 1919, the numbers of animals passing through these points were about 25 million cattle, 27 million sheep, and 45 million hogs, which, although including many

<sup>1</sup> Methods and Cost of Marketing Live Stock and Meats, Report 113, Office of the Secretary, U. S. Department of Agriculture, page 39.

duplications due to counting stock at more than one point, still represent a considerable majority of the meat animals marketed in the United States.

Natural economic conditions have been chiefly responsible for the development of these market centers. Unlike the more thickly and homogeneously populated countries of the Old World, our largest consuming and distributing centers and export points are located along the Atlantic seaboard while our supply of meat animals is chiefly in the middle and western sections. This situation precludes the direct local movement of meat animals from producers to retail dealers, except to a limited extent. Consequently the development of large live-stock markets and packing centers at intermediate points was inevitable. With the gradual westward drift of the centers of population and industry, together with the development of improved transportation, refrigeration, and methods of packing and distribution, a corresponding development of live-stock markets has occurred at points nearer the producing centers, and at the present time such markets exist in almost all parts of the United States.<sup>1</sup>

Coincident with their remarkable development in magnitude and organization, these great markets have produced problems which have a vitally important bearing upon live-stock production and which, therefore, directly affect every citizen either as a producer or as a consumer of meats. The root of these problems consists in the concentration of ownership and control of the stockyards and other facilities at many of the important live-stock centers, which gradually have been absorbed by Chicago meat-packing interests. These interests, according to the Federal Trade Commission, now own or control 28 stockyards through which pass 84 per cent of the live stock shipped to market centers in this country.<sup>2</sup> As this group of packers is regarded by most stockmen and farmers as a virtual monopoly in their control of the meat supply, and as it is considered that they are able to manipulate market prices and movements to a large extent, the consequent effect of their gradually gained domi-

---

<sup>1</sup> Great Central Markets for Live Stock and Meats. Proceedings of Second Pan-American Scientific Congress, Vol. III, p. 335-341.

<sup>2</sup> Report of the Federal Trade Commission on the Meat Packing Industry. Part III, p. 11.

nation of most of the principal stockyards and of the meat trade in the largest cities has been a growing distrust and dissatisfaction on the part of live-stock producers with regard to marketing conditions.

The resultant situation relative to the production of meat animals is shown strikingly by the diagram below, which means, substantially, that the beef cattle supply remained at a standstill for 20 years before the war with Germany, and the hog supply for practically 30 years, while the number of sheep had diminished heavily. Although production was stimulated by the rising prices and by the optimism which naturally spread among food producers after the magnitude of Europe's war-time food needs became apparent, still the discrepancy between the domestic demand and the limited

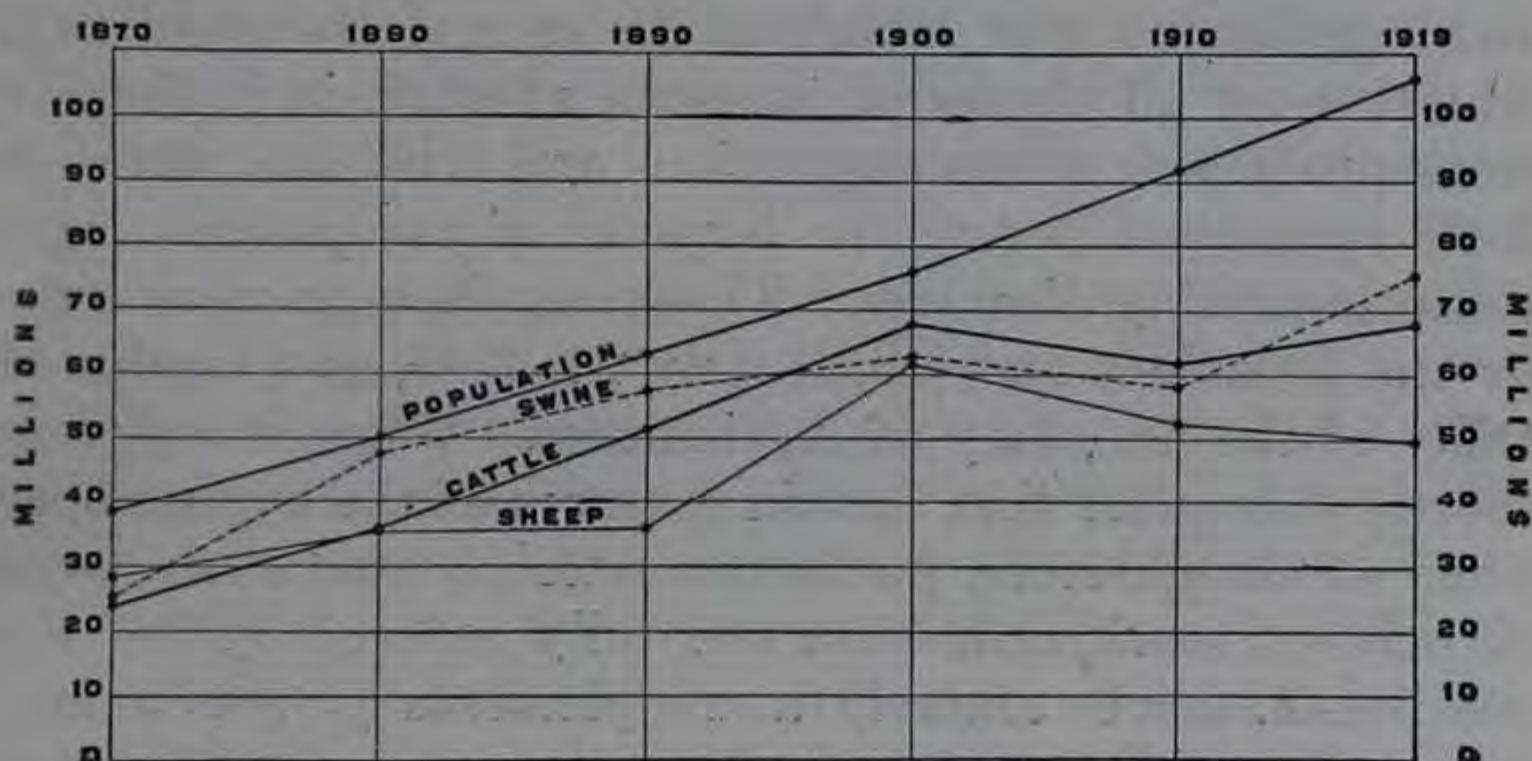

Trend of Population and Live Stock in the United States, 1870 to 1919.

supply of live stock, together with the apparent need for greatly increased quantities of meat for the fighting forces, produced a serious situation which had a critical bearing on our position from a military point of view. Under these circumstances, the President, at the suggestion of the Food Administrator in March, 1918, appointed a commission to consider and formulate a national policy relative to the meat supply. Recognizing the prevailing lack of confidence as an important factor in the situation, this commission recommended to the President the licensing and regulation of the stockyards, the establishment of a governmental system of animal grading, and the official reporting of the distribution of live stock, meats, and other products from prin-

cipal packing points. Pursuant to this recommendation, a proclamation making it effective was issued by the President, June 18, 1918, under authority of the Food Control Act. The organization and administration of the live stock market supervision service was immediately undertaken by the Department of Agriculture at the direction of the President, the Chief of the Bureau of Markets being designated as the administrative officer in immediate charge of this service.

In accordance with the President's proclamation, the stockyards, live stock commission firms, traders, and order buyers subject to license were notified of the license requirements, which became effective July 25, 1918, to remain in force until the conclusion of peace. A tentative draft of rules and regulations was submitted to several thousand representatives of all classes of interests affected, including live-stock producers, whose suggestions and criticisms were carefully considered before the issuance of the general regulations governing licensees. These regulations were signed by the President and issued July 26, 1918, as Circular 116, Office of the Secretary of Agriculture. When it was found shortly thereafter that certain features of the buying operations of slaughterers, packers, renderers, and other buyers in licensed stockyards were not fully covered by the Food Administration's control, a supplementary proclamation pertaining to those classes of business was issued by the President on September 6, 1918, and the general regulations were amended accordingly.

The general principles aimed at in the drafting of the regulations were to require adequate facilities, equipment, and service at live-stock markets; to prevent extortionate or excessive charges for yardage, feed, commissions, and other service; to prohibit unfair dealing, deceptive practices, and unwarranted combinations, manipulations, or discrimination in the purchase and sale of live stock, including the circulation of false or misleading market information; to require the keeping of full and accurate records by licensees, such records to be subject to examination by authorized officials; and otherwise to foster and further open and fair competition in efficiently conducted market places.

The issuance of licenses proceeded promptly from the effective date (July 25) fixed by the President's procla-

mation, and shortly thereafter substantially all concerns affected had been duly licensed. Licenses are now held by 123 stockyards, 410 commission men, 115 order buyers, 1,052 traders, speculators, and scalpers, 304 slaughterers, meat packers, renderers, and other buyers, and by 988 licensees conducting various combinations of these lines of business, making a total of 2,992. One hundred and eighty-six licenses have been canceled, including those surrendered on account of discontinuation of business and two cases of violation of regulations. A number of additional cases are pending.

To expedite the organization of a corps of competent market supervisors and assure the effective administration of the regulations, several men of recognized standing and successful experience in different branches of the live-stock industry were added temporarily to the live-stock staff of the Bureau of Markets. Local representatives of the bureau's live-stock market report service, who already were stationed at the stockyards at Chicago, Kansas City, Omaha, East St. Louis, South St. Paul, Denver, Salt Lake, and Portland, were instructed to perform the duties of acting market supervisors at their respective markets. As rapidly as other competent supervisors were available the service was installed at the following additional points: Billings, Boston, Buffalo, Cincinnati, Cleveland, Fort Worth, Indianapolis, Jacksonville, Lancaster, Louisville, Nashville, New Orleans, New York, Oklahoma City, Philadelphia, Pittsburgh, San Francisco, Sioux City, St. Joseph, and Washington. The supervisors in charge of these 28 markets also were made responsible for the supervision of the various other stockyards in their respective districts. Thus all of the licensed stockyards in the United States were shortly brought under effective supervision. Assistant supervisors also have been assigned to some of the larger markets, such as Chicago, Kansas City, Omaha, and East St. Louis. On account of the curtailment of available funds and the anticipated conclusion of peace, the branch offices of this service at Billings, Buffalo, Cincinnati, Cleveland, Jacksonville, Lancaster, Nashville, Oklahoma City, Salt Lake, Sioux City, and St. Joseph have been discontinued since July 1, 1919.

Many hundreds of complaints and adjustments have been handled by the local supervisors, illustrative of which may

be mentioned the installing of needed stockyard facilities, such as scales, pens, alleys, chutes, docks, and viaducts; employing additional yardmen to relieve congestion of stock in the yards; requiring the furnishing of feed of suitable

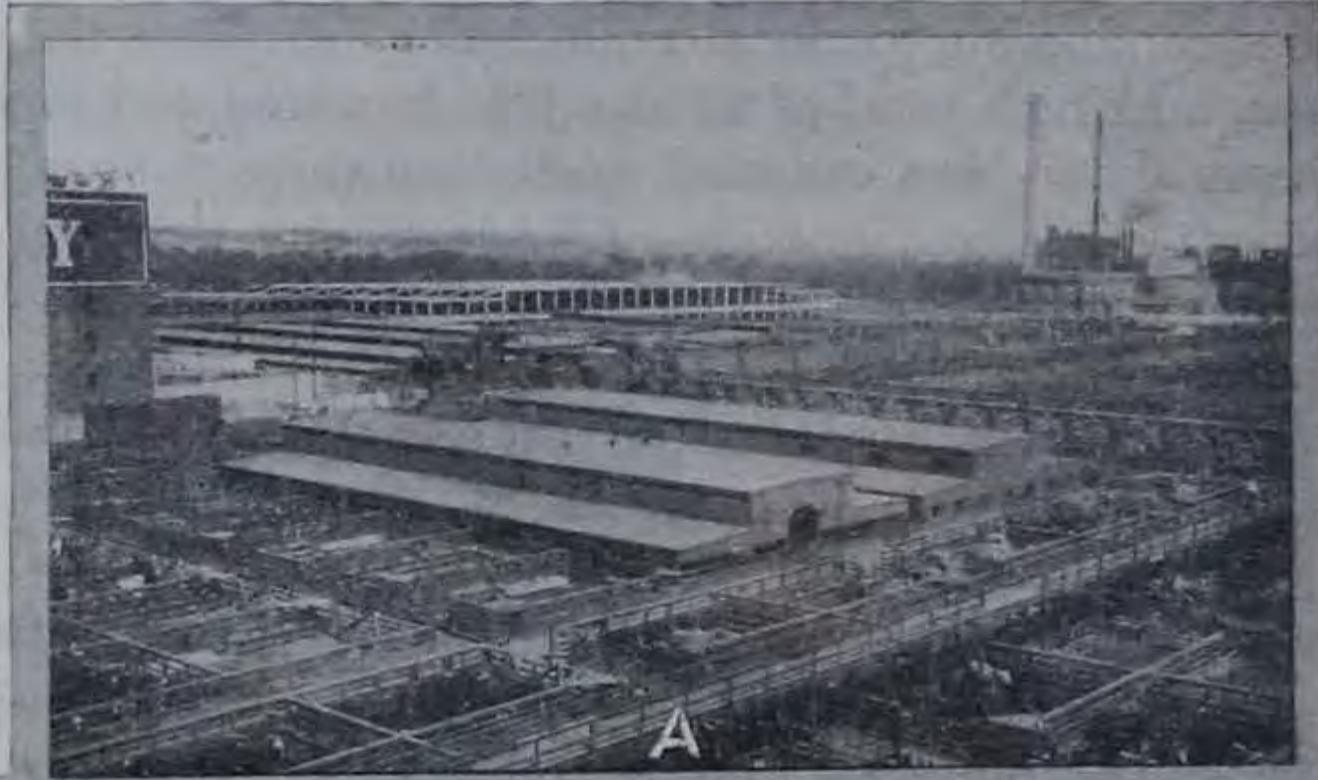

**In the Stockyards.**

*A.* A well-equipped stockyard showing sheep house (rear) and hog sheds (center). *B.* Cattle alleys and exchange building in a typical stockyard.

quality and accounting for feed at actual or carefully estimated weights; reducing excessive charges for feed; cleaning pens and alleys which were unfit for use; rearranging weighing schedules and promoting earlier hours of trading to eliminate avoidable congestion and delays; correcting

abuses in the disposal of crippled animals; tipping stockyards employees to secure special privileges in yarding and handling stock; deceptive practices in the buying and selling of stock; and readjusting inadequate rates of payment for dead stock.

As an example of the readiness with which the trade cooperated in bringing about these improvements, the following notice issued by the Chicago Live Stock Exchange on June 25, 1918, to its members is cited:

In view of the proposed licensing of commission merchants under the proclamation of the President of the United States and the probability that licensees will not be permitted to take advantage of any assistance from so-called crippled hog traders, scalpers, or followers, the board of directors of this exchange has this day caused to be issued this notice, taking effect July 1, 1918, that on and after that date commission merchants shall yard all stock from the trains, feed, water, and weigh same by their own employees, and that no service whatever shall be given or rendered by any persons not on the payroll of a commission concern.

These instructions did not alter the arrangement whereby the stockyard company renders certain services in the delivery of stock and feed to pens. This action was designed to eliminate one of the most common causes of complaint against the methods of handling consignments of stock in the yards.

The following notice issued by the acting market supervisor at Chicago illustrates the manner in which earlier hours of trading were promoted at that important point:

At a meeting held on April 8 of officials and representative members of the Chicago Live Stock Exchange and Traders' Live Stock Exchange, packer buyers, and officials of the Union Stock Yards and Transit Company with representatives of the Bureau of Markets, the matter of an earlier market at Chicago was considered. It was agreed that the earliest hours of trading consistent with the proper handling of the stock are desirable and to the advantage of all interests concerned and representatives of the various interests present expressed their willingness to cooperate with the Bureau of Markets to that end. Officials of the Stock Yards Company stated that the scales would be opened and ready to receive and weigh stock earlier than at present if the advancement of the hours of trading renders this necessary. Effective Monday, April 14, commission men will be expected to have their stock ready to offer for sale not later than 9 o'clock, as far as possible, and buyers to be in the yards ready to buy by that time. It will be understood that the early appearance of buyers and sellers on the market does not necessarily indicate an unusual market condition but is in compliance with the plan for the establishment of an earlier market.



Patrons and members of the trade at various markets have stated that the stockyards have been kept in a cleaner condition since supervision was inaugurated than ever before. Enthusiastic friends of the service at one of the important stockyards state that the annual saving in shrinkage effected by the improvement in terminal switching and unloading of stock trains at that point amounts to more than the total cost of supervision at all markets. It is generally agreed by all who have carefully observed the working of the service that the activities of the local supervisors and their assistants, besides producing many actual savings and correcting numerous specific abuses, have also prevented many former irregular practices and exerted a salutary influence on trading conditions through their mere presence on the market.

Among the matters referred to the Washington office for consideration, those of principal importance, and in which public hearings have been held, are increased rates of commission and yardage, alleged discrimination by members of live stock exchanges against nonmembers, discrimination by a stockyards company as to the use of vaccinating facilities and privileges, theft of live stock, false returns to consignors, and overcharges for feed by stockyards and commission firms. A commission firm which made a practice of rendering false returns was required to restore to its shippers more than \$18,000 and its license was canceled. Another licensee has been caused to refund over \$20,000 wrongfully withheld through the manipulation of feed accounts. Other irregularities disclosed through complaints or by auditors and investigators of the supervision service have been dealt with as the circumstances appeared to warrant. Considering the number of concerns licensed and the immense volume of business affected, it is only fair to say that the abuses found have been comparatively few, and, with some exceptions, not of a flagrant sort.

In accordance with a further recommendation of the President's Meat Commission, specific attention has been given by the Bureau of Markets to the development of standard market classes and grades of live stock, in connection with the supervision of live-stock markets and the market report service.<sup>1</sup> Specialists in live-stock classification,

---

<sup>1</sup> Government Market Reports on Live Stock and Meats. Yearbook, U. S. Dept. of Agriculture, 1918, pp. 379-398.

together with the Bureau's local representatives, were assigned to a thorough investigation and comparison of the market classifications in use at Chicago, Kansas City, Omaha, East St. Louis, Fort Worth, St. Joseph, Sioux City, and St. Paul. On the basis of this investigation a uniform classification was adopted for use in live-stock reports at all markets from which quotations are issued by the Bureau, and for the guidance of all the market supervisors. This marks an important step in the stabilization and supervision of market conditions, furnishing, as it does, an entirely new and long-needed means of comparison between prices of live stock sold at the various markets, and between prices of



Waiting for a Buyer.

live animals and corresponding grades of dressed meat. Records also have been kept showing the numbers and prices of live stock purchased by slaughtering concerns, and shipments of live stock, including stockers and feeders, from the various markets. Preliminary arrangements also have been made for the reporting of dressed meat shipments from principal packing points, but it has been impracticable as yet to put this feature into operation because of the lack of sufficient assistance.

Besides the duties specifically provided for in the President's proclamation, the administrative staff and local supervisors have cooperated actively with other branches of the

Government in important activities pertaining directly to the live-stock markets. Information and assistance have been furnished to the Railroad Administration in connection with the revision of train schedules and terminal switching arrangements so as to secure the arrival of stock at markets earlier in the day; in the development of uniform rules for feeding in transit; and in the conduct of embargoes against live-stock shipments during the periods of excessive market receipts. Committees appointed by the Federal Food Administrator for the administration of an agreement relative to minimum prices for live hogs were furnished the services of local supervisors and the use of the bureau's facilities for the collection and distribution of pertinent information, thereby assisting materially in the stabilization of the hog market at a most critical period.

In connection with the selection and grading of dressed beef for the Army, Navy, and fighting forces of the Allies, for which the Department of Agriculture was responsible temporarily and which required the rapid organization and prompt inauguration of an inspection service at the principal market centers by the Bureaus of Markets and Animal Industry, representatives of the stockyards supervision service, many of whom were experienced in the grading of beef, assisted effectively in starting and maintaining this important function, which exerted a direct and beneficial effect upon the live-stock markets by creating a needed outlet for choice and good beef of lighter weights than previously had been included in the specifications.

Constructive methods, constant counsel with competent and recognized representatives of the various interests concerned, conservative action in cases requiring the exercise of administrative authority, and absolute fairness to all parties affected, have been the policies of those responsible for the conduct of this service. Despite the brief period of its existence and the consequent imperfections, mistakes, and lack of complete efficiency which characterize all new enterprises of such scope, the initial results nevertheless demonstrate conclusively the value and the possibilities of such a supervision over the markets through which passes the bulk of the Nation's meat supply.

# COOPERATIVE IMPROVEMENT OF CITRUS VARIETIES

By A. D. SHAMEL,

*Physiologist in Charge of Fruit-Improvement Investigations, Office of Horticultural and Pomological Investigations Bureau of Plant Industry.*



## IMPORTANCE OF THE CALIFORNIA CITRUS VARIETIES.

**D**URING the crop year 1918-19 about 39,100 carloads of oranges and grapefruit and 9,963 carloads of lemons, or 49,063 carloads of citrus fruit, were shipped from California. In the wholesale markets this crop brought more than \$100,000,000. After the expenses incurred in packing, transporting, and marketing were deducted from this amount, approximately \$75,000,000 was returned to the citrus growers in California.<sup>1</sup>

Only a few varieties of citrus fruits were grown to produce this result. The Washington Navel orange crop, which ripens during the winter months, amounted to approximately 17,000 carloads; the Valencia orange crop, which ripens during the summer months, amounted to about 20,000 carloads. Other orange varieties of minor importance produced about 1,500 carloads. The Eureka and Lisbon varieties of lemons, differing mainly in the season of production, so that mature fruits are marketed during the entire year, produced 9,963 carloads. The Marsh is the only grapefruit variety grown commercially, and this crop, which

<sup>1</sup> Information furnished by the California Fruit Growers' Exchange.

ripens during the summer months, amounted to about 600 carloads of fruit.

The high commercial reputation of the California citrus fruits has largely resulted from marketing regular and uniform supplies of good fruit produced by a few standard varieties, which are readily identified by the trade and by the consumers. For this reason the importance to the citrus industry of conserving and improving these varieties, now that their reputation has become fully established, must be apparent to every thinking person.

Most of the development of the citrus industry in California to its present great commercial importance has taken place within the last 25 years. Its rapid growth during this period is one of the marvels of horticulture. The principal markets for the crop are a long distance from where the fruit is grown. The climate, soil, and cultural conditions in the citrus districts necessitate constant vigilance and intelligent effort in order to produce successful crops. These and other circumstances have resulted in the development of many improved cultural and marketing practices, largely by the aid of scientific research, which have proved to be invaluable not only in the profitable growing and marketing of citrus crops in California, but also in the production and marketing of fruit crops in other sections of the United States.

#### OCCURRENCE AND FREQUENCY OF BUD VARIATION.

During recent years many California citrus growers have noticed the presence of undesirable trees in their orchards. This condition seemed more apparent in young orchards or those farther removed from the original trees from which the varieties developed than in the older orchards which were more closely related to the original parent trees. Many of these trees apparently produced irregular, light crops of inferior quality. In some cases the commercial and eating quality of the fruit from the offtype trees proved to be so poor that it became necessary to sort them out from the general crop and throw them into the cull bins. This condition increased the expense of assorting the crop and also materially reduced the merchantable yield of the orchards. In many instances the inferior and worthless fruits from the undesirable trees could not be easily identified in the

packing houses and were inadvertently included with the regular pack; the consumer was disappointed in their eating quality, and a loss of reputation for the crop as a whole inevitably resulted.

Acting upon the request of some of the leading citrus growers in southern California, the Bureau of Plant Industry in 1909 began an investigation for the purpose (1) of ascertaining the variations which have taken place in the important commercial citrus varieties grown in California through bud variations and to learn the comparative value of the different strains arising from these variations for commercial fruit production; (2) to determine the extent to which undesirable variations have been propagated, as shown by the percentage of such undesirable trees existing in the parent bearing orchards; and (3) through improved methods of propagation to reduce the number of undesirable variations which enter into commercial citrus-fruit orchards.

These investigations have been carried on by means of records and observations of individual trees. The term "performance record" is used here to mean the record of the number and commercial quality of fruits borne by individual trees during a period of years. Mostly these studies were made in performance-record plats, consisting of groups of trees grown under comparable conditions, selected for the purpose of determining the behavior of the trees by means of individual-tree records of production, observations, descriptive notes, and photographs.

In addition to securing accurate individual-tree yield records, a very careful study of the tree, flower, and fruit characteristics was made. These data showed that striking bud variations were of frequent occurrence in many of the citrus trees. For example, typical Washington Navel orange trees each grown from a single bud and bearing fruits similar to those shown in figure 1, were often found bearing several distinct types of navel oranges, such as those shown in figure 2. In some cases these variations occurred as single fruits possessing characteristics different from those of the Washington Navel orange. In other instances Washington Navel orange trees were discovered having one large limb bearing many fruits which were so different from the other fruits on the tree as to be classed as belonging to

a totally different variety. Several individual trees were found on which nine different strains of the navel orange were borne on different limbs, all of them arising as bud sports in these trees. The differences in the characteristics of the fruit variations in some of the trees were found to be almost as important from the commercial standpoint as those which differentiate horticultural varieties. These

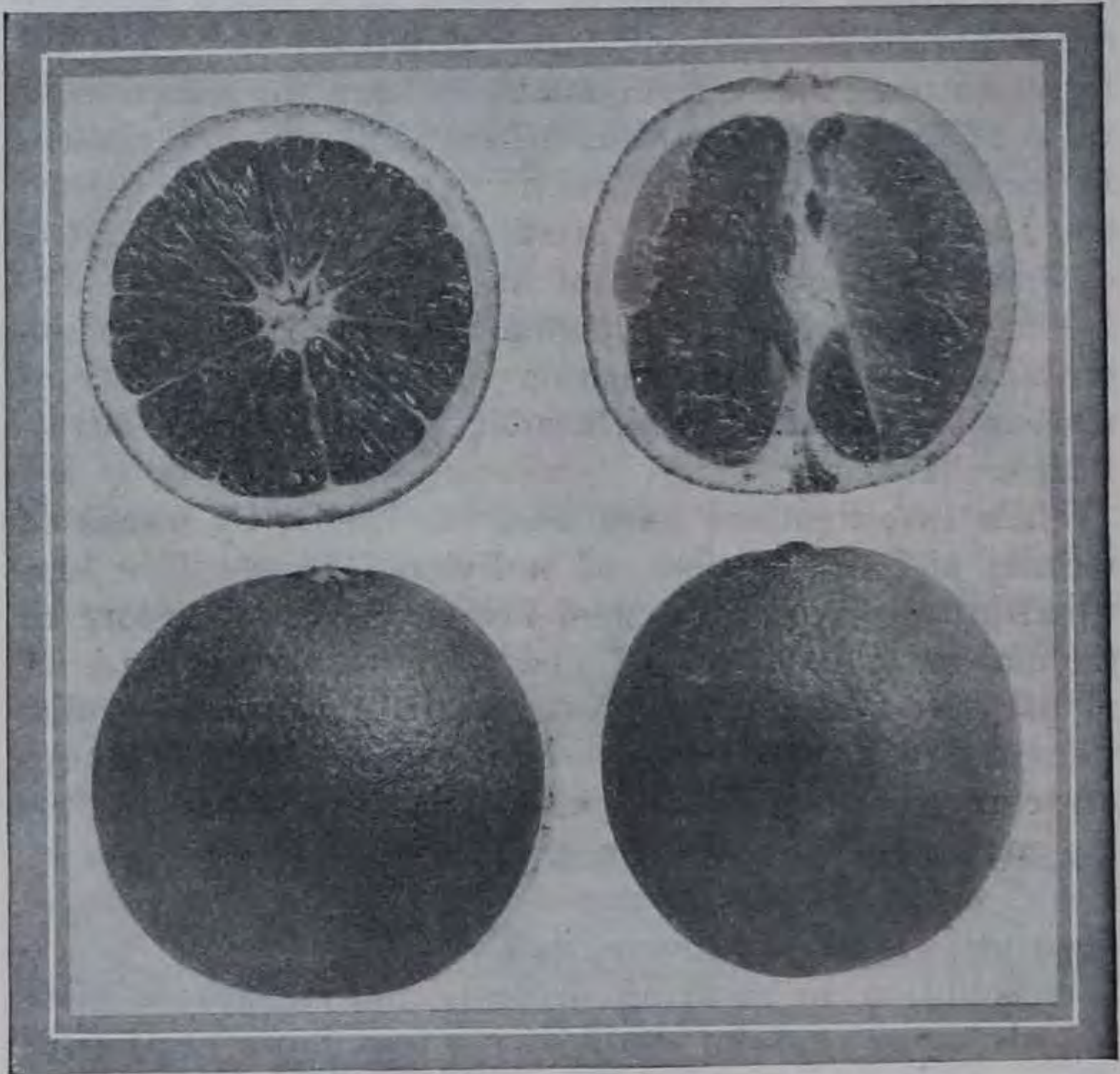

Best Strain of the Washington Navel Orange.

FIG. 1.—Typical fruits from a tree of the best strain of the Washington Navel orange variety.

variations were not confined to the Washington Navel orange, but were found almost as frequently in the trees of the other varieties studied.

The number of the important fruit variations borne by individual citrus trees differed greatly. A few trees in all of the varieties have been found without any apparent or marked variation in fruits other than the usual modifications of size, shape, texture of rind, color, and quality which are probably due to the influence of season, culture, or other

environmental conditions. Fortunately, from the standpoint of the conservation and improvement of the varieties, the inherent variations have been found to occur most frequently in the trees of the inferior strains of all of the varieties. The most productive trees in all cases so far studied and those bearing the most desirable fruits have produced comparatively few of these marked fruit or other bud variations.<sup>1</sup>

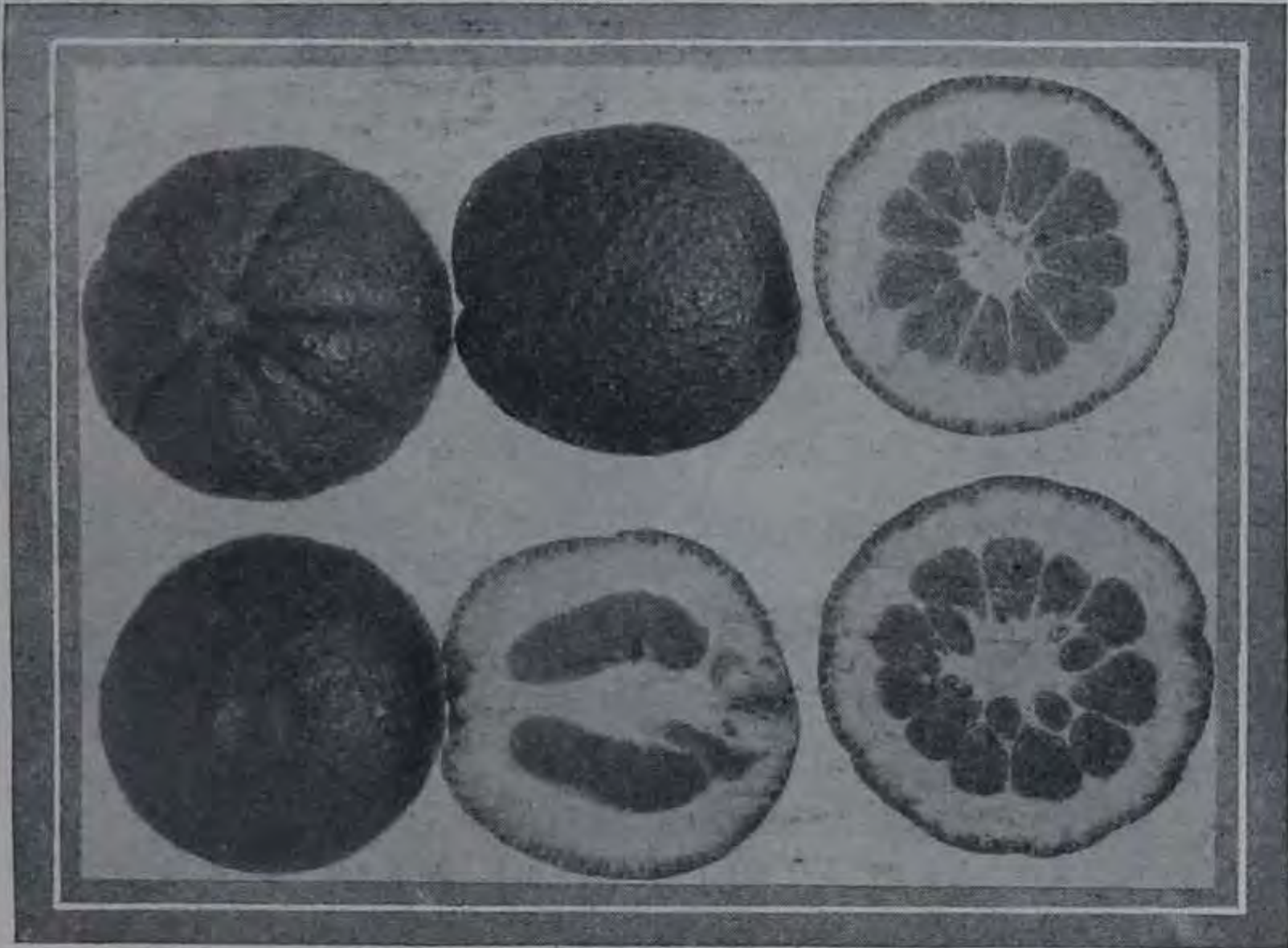

Dry Strain of the Washington Navel Orange.

FIG. 2.—Typical fruits from a tree of the dry strain of the Washington Navel orange variety, showing the undesirable and worthless characteristics of the fruits of this strain. This and other inferior strains originated as bud variations of the best strain, and their accidental propagation has been the source of great loss annually to the growers possessing them.

#### ORIGIN OF STRAINS.

The term "strain" is here used to designate a group of individuals of a horticultural variety which differ from all other individuals of the variety in one or more constant and recognizable characteristics capable of perpetuation through vegetative propagation.

<sup>1</sup> The detailed results of the investigation of the variations of citrus varieties in California have been presented in a series of publications of the United States Department of Agriculture. These reports are in Department Bulletins 623, 624, and 697, to which the reader is referred for further information as to the occurrence and frequency of bud variations.



One of the first and most important individual fruit variations observed in Washington Navel orange trees was a large, coarse fruit, which is commonly called an Australian Navel orange. Soon after the discovery of this single fruit variation in the crop of a typical Washington Navel tree, a limb was found in a near-by Washington Navel tree bearing 56 typical Australian fruits. A further study of this



Several Strains of Lemons from the Same Tree.

FIG. 3.—Typical fruits of several strains produced by different branches on a variable Lisbon lemon tree which was grown from a single bud.

orchard revealed several trees bearing all, or nearly all, Australian fruits, and having the peculiar upright habit of growth so characteristic of the trees of this strain.

An investigation of the single fruit variations found in the trees of the varieties studied revealed their occurrence in other trees as limb sports and in other cases as individual trees. This condition illustrates the probable origin of the

many diverse strains in citrus varieties, due to the accidental propagation of limb sports, and is an important reason for obtaining performance records for use in the selection of bud wood for propagation.

So far, 13 strains of the Washington Navel orange, 12 strains of the Valencia orange, 6 strains of the Marsh grapefruit, 8 strains of the Eureka lemon, and 5 strains



A Drone Tree.

FIG. 4.—A typical unproductive or drone tree of the shade-tree strain of the Eureka lemon variety. The trees of this strain show extraordinarily rank vegetative growth and bear light, inferior crops as compared with the trees of the productive strain.

of the Lisbon lemon varieties have been found, their characteristics described, and the behavior of typical trees determined. The origin of all these strains has been traced to bud variations, examples of which are shown in figure 3. Their distribution in established orchards has been largely the result of accidental propagation of the bud variations, due to a lack of knowledge of the importance of the varia-

tions and their significance in the work of maintaining the citrus varieties.

The extent of the occurrence of trees of the diverse strains of the citrus varieties in California has been studied carefully



A Productive Lemon Tree.

FIG. 5.—A typical productive tree of the best strain of the Eureka lemon variety.

in many districts by means of orchard surveys. The percentage of offtype trees, that is, trees belonging to strains different from those desired in the orchards and usually inferior to them, has been found to vary from 10 to approximately 90. An average of 25 per cent of the trees in the

orchards studied have been found to belong to strains which differ markedly from the typical or best strain of the variety. The largest percentage of variations from the superior strains has been found in the younger orchards.

The trees of one of the strains of the Eureka lemon variety possess unusual vigor of growth and habitually bear light crops of inferior fruits. A typical tree of this strain is shown in figure 4. On account of their large size as compared with the trees of the productive strain, the density of their foliage, and their poor crops, they have been called shade trees. These trees usually develop a

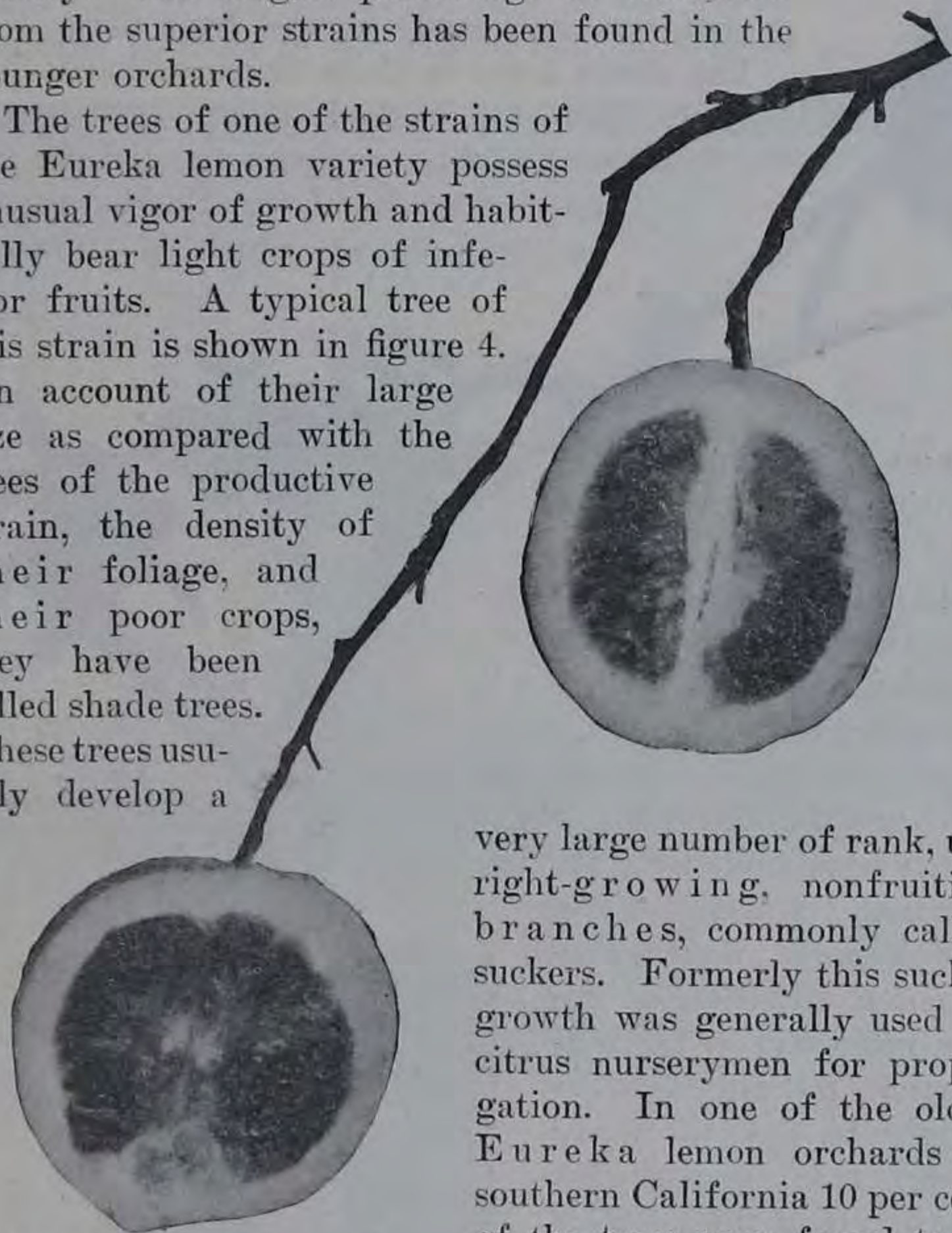

Orange Variations on the Same Branch.

FIG. 6.—A branch from a Ruby blood-orange tree bearing a fruit possessing a navel and a normal fruit without a navel; an example of the variation of fruits frequently found in citrus trees.

very large number of rank, upright-growing, nonfruiting branches, commonly called suckers. Formerly this sucker growth was generally used by citrus nurserymen for propagation. In one of the older Eureka lemon orchards in southern California 10 per cent of the trees were found to be of the Shade-Tree strain. In a younger orchard, the trees of which had been grown from sucker buds secured in the older grove, 25 per cent of the trees were found to be of this

strain. In a still younger orchard, where the trees had been grown from sucker buds secured in the second orchard, the percentage of shade trees was found to be 75. This astonishing increase in the percentage of shade trees in the younger

orchards is due to the fact that the bud cutters in each instance secured a large share of their bud wood from the trees of the Shade-Tree strain, as the sucker growth was most easily secured from them.

The shade trees in these three orchards have recently been top-worked, using fruit-bearing bud wood secured from superior trees of the Productive strain of the Eureka variety, an example of which is shown in

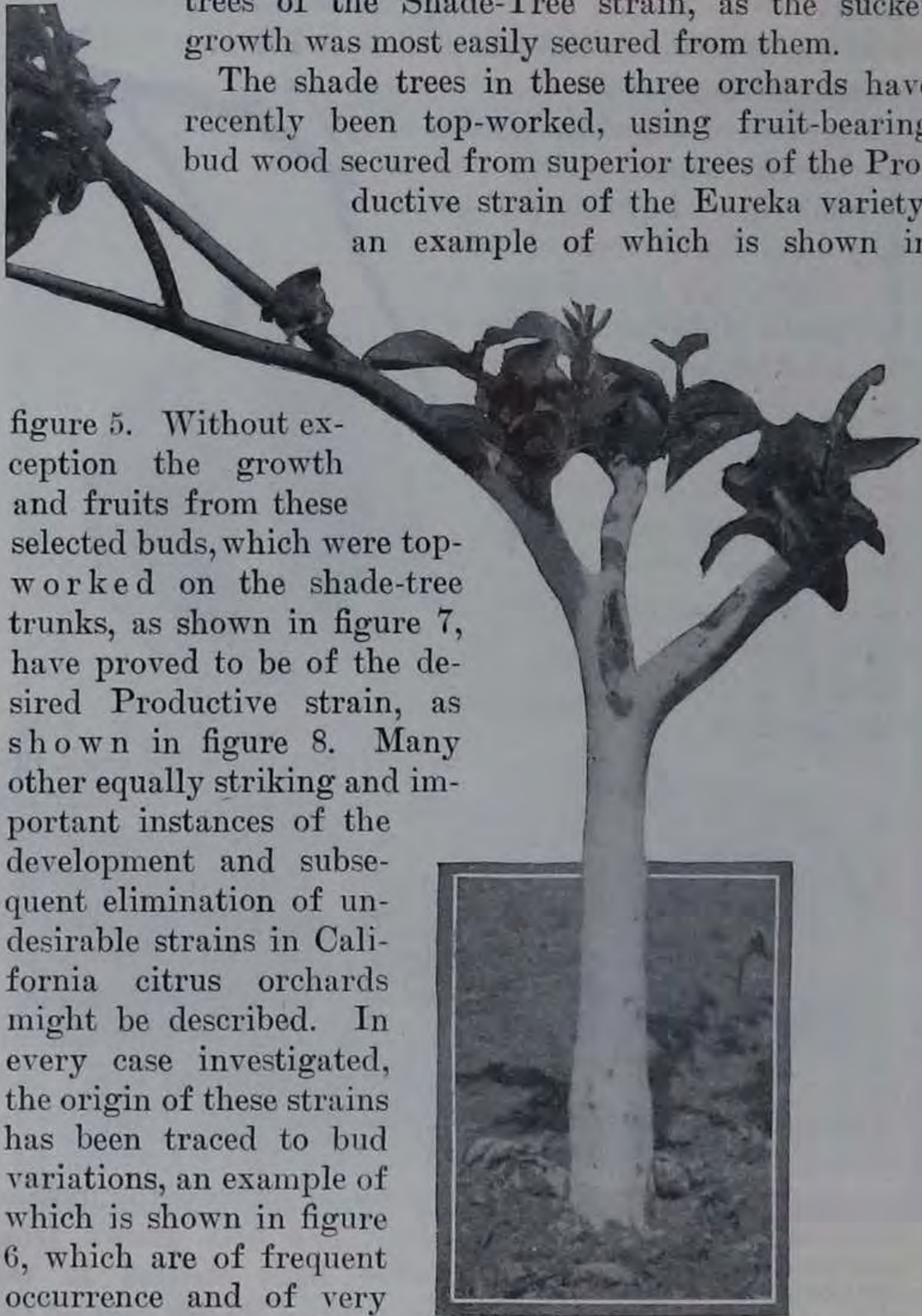

figure 5. Without exception the growth and fruits from these selected buds, which were top-worked on the shade-tree trunks, as shown in figure 7, have proved to be of the desired Productive strain, as shown in figure 8. Many other equally striking and important instances of the development and subsequent elimination of undesirable strains in California citrus orchards might be described. In every case investigated, the origin of these strains has been traced to bud variations, an example of which is shown in figure 6, which are of frequent occurrence and of very great importance from the viewpoint of the conservation and improvement of the established citrus varieties.

A Top-Worked Shade Tree.

FIG. 7.—A typical Eureka lemon shade tree, such as that shown in figure 4, top-worked with buds secured from a superior performance-record parent tree, such as that shown in figure 5. This photograph was taken three months after top-working.

ISOLATION OF THE STRAINS.

Enough evidence has been secured to warrant the assertion that all the strains of each of the citrus varieties discovered in these investigations can be isolated through bud



Good Results from Top-Working.

FIG. 8.—A top-worked shade tree of the Eureka lemon variety, such as that shown in figure 1, three years after top-working. The barren, rank growth of the original shade tree has been replaced with the productive normal growth of the best strain. Out of 16,000 trees in this orchard 3,200 worthless shade trees have been successfully top-worked.

selection. This conclusion is not intended to convey the idea that bud variation within these strains can be entirely eliminated; on the contrary, the investigations have shown that some variation will likely continue as long as the strains are propagated.

What has been demonstrated is that variation can be controlled by bud selection to such an extent that the individuals of the strain can be brought to a condition of practical uniformity as regards crop production and other characteristics. At this time there are several thousand acres of bearing citrus orchards in California in which the trees have been propagated from carefully selected buds, secured from superior performance-record trees. In these orchards the progenies of each of the parent trees have been kept separate. Performance-record studies of these progenies and a comparison of their behavior with that of the parent trees conclusively demonstrate that through bud selection each of the important citrus strains has been isolated. The uniformity of the progenies and the superior and heavy crops of those of desirable strains have proved beyond any doubt that it is practicable commercially to isolate and propagate only the best strains and to eliminate the inferior ones through careful bud selection, based upon individual-tree records and intimate tree knowledge.

#### COMPARATIVE VALUE OF THE STRAINS.

As a rule, only one of the many strains in each of the citrus varieties has been found to be worthy of commercial propagation and profitable for cultivation. The value of the product of the trees of the best strains as compared with that of the trees of the inferior strains may be illustrated by the records of production of the trees of the best Washington Navel orange strain and those of the inferior Australian strain in the investigational performance-record plot. In these studies it was found that the trees of the best Washington Navel strain produced an average of 4.73 packed boxes of oranges per tree per year during the period of observation. Under similar conditions the trees of the Australian strain produced 0.76 of a packed box per tree per year. On an acre basis, this yield amounted to 378.6 packed boxes per acre for the best trees, compared with 61 packed boxes per acre for the inferior trees. The actual value of this production was \$635.05 per acre annually for the high-producing trees, as compared with \$100.04 for the low-producing trees of the undesirable strain. Even greater

differences in production and value of the crops from the trees of different strains have been found in other varieties. When it is remembered that on the average 25 per cent of the trees in the orchards studied have been found to be inferior strains, the commercial importance of growing only trees of the best strains can be appreciated.

#### OBJECT OF COMMERCIAL TREE-RECORD WORK.

The trees of the best strain in each variety have usually been found to be the heaviest producers of fruit. On the other hand, the trees of the inferior strains have usually been found to bear light crops of inferior commercial quality. For this reason individual-tree records of production are of very great value in determining the proportion of different strains of trees in citrus orchards.

The demonstration of this condition in both experimental and commercial tree-record work has led many of the leading citrus growers to undertake individual-tree record work in their orchards. Such records are now being kept on more than 50,000 acres of citrus orchards in California.

The object of the commercial tree records is (1) to locate the drone trees, or those of the inferior strains in the orchards; (2) to find the superior trees, or those from which bud wood may be secured for propagation; (3) to aid in giving the trees individual care, such as cutting out limb sports or other undesirable growth, treatment for disease, or any tree injury; and (4) to secure definite evidence as to the effect of cultural treatments and other experimental tests.

#### METHOD OF KEEPING INDIVIDUAL-TREE RECORDS.

The method of keeping individual-tree records in citrus orchards now commonly used in California will be briefly described. Various minor modifications of this method have been and are being tried in some orchards, but the principles underlying this work are fundamentally the same in all cases. It may be found advisable to modify or change the method somewhat, owing to local conditions, but these changes should not be made until experience has shown them to be necessary in order that the records may be secured in the most natural and logical manner.



## INDIVIDUAL-TREE NUMBERS.

Each individual tree in the orchard receives a number. This number consists of three parts, (1) the number of the block or division of the orchard, (2) the number of the row in the block, and (3) the position of the tree in the row, always counting from some fixed point, as, for example, the

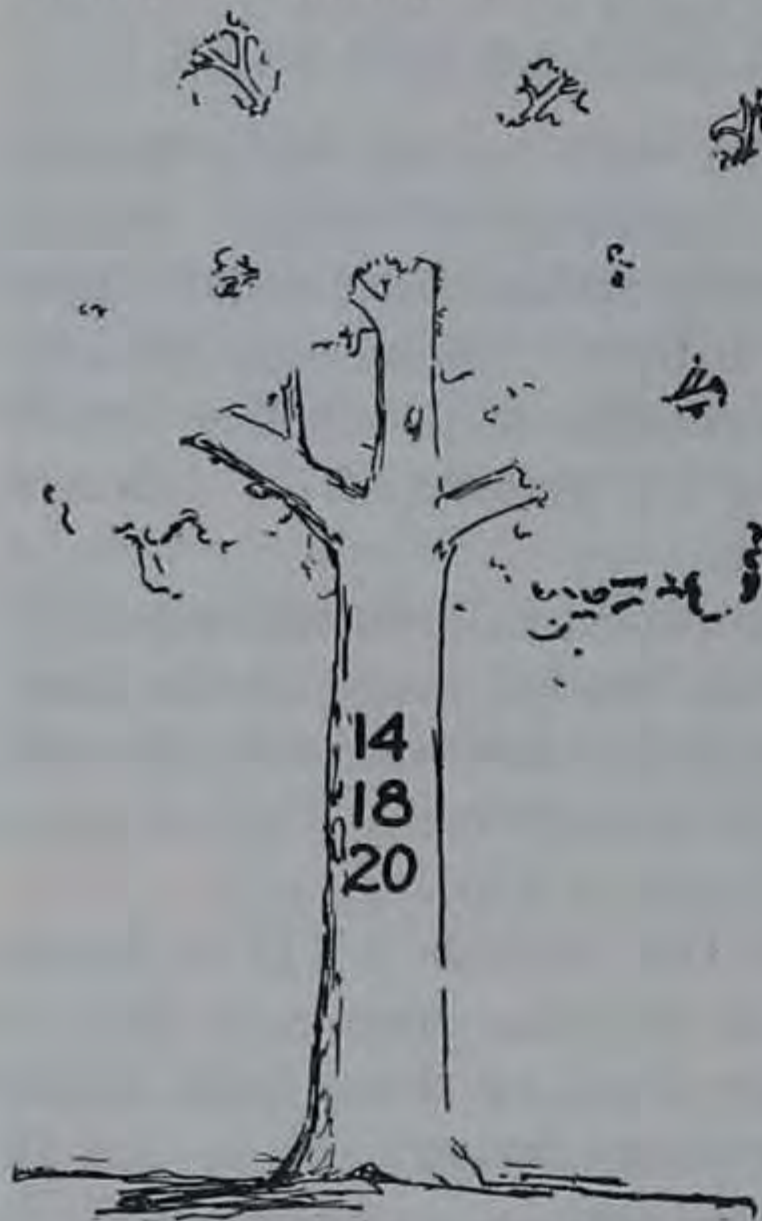

Individual-Tree Numbering.

FIG. 9.—The arrangement of an individual-tree number on the trunk of a bearing citrus tree in a commercial orchard.

irrigation head. A tree located in block 14, row 18, and the twentieth tree in the row, has the number 14-18-20. Where there are several different orchards the tree number in the performance-record notes is preceded by the number or name of the orchard or its abbreviation.

In the case of bearing trees this number is painted on the tree trunk or on one of the main limbs, arranging the number in a vertical column in the form shown in figure 9. The figures are made with a common lettering brush and pure white-lead paint. Very young trees, on which space is not available for painting the number, are designated by attaching a

metal or other tag bearing the number.

The tree numbers are always placed in the same relative position on all the trees in the orchard, for convenience in finding them. Large, distinct figures are made, so that they are easily legible. The cost of tree numbering has varied somewhat with labor conditions, but at present the numbers are being applied at an average cost of about 2 cents a tree.

## PICKING.

When picking the trees where individual-tree records are secured it is usually necessary to distribute the field boxes to the individual trees instead of in box rows, as is ordi-

narily done. Each picker gathers the fruit from one tree, and usually the same man picks all the trees in each row. All the fruit from each tree is placed in boxes at its base, as shown in figure 10. Care is taken in the beginning to



• Commercial Performance Record Taking.

FIG. 10.—Securing performance record of the number of full boxes and the weight of a partly filled box of fruit produced by a Washington Navel orange tree in a commercial orchard.

see that none of the fruit from a tree is accidentally carried in the picking sack to a neighboring tree. Pickers quickly realize the importance of keeping the fruit of each tree separate. In some instances this arrangement has been found to stimulate care in picking and to accelerate markedly the rate of picking. Each picker's work is always open to inspection. With one picker on a row the natural tendency

is to induce the slower pickers to keep up with the faster workers. Inasmuch as the field boxes are near the tree being picked, this arrangement does away with the necessity for each man walking with his filled picking sack from the tree to the box row, as was formerly the case, and in this way saves considerable time. Extensive experience with commercial individual-tree picking work during the past eight

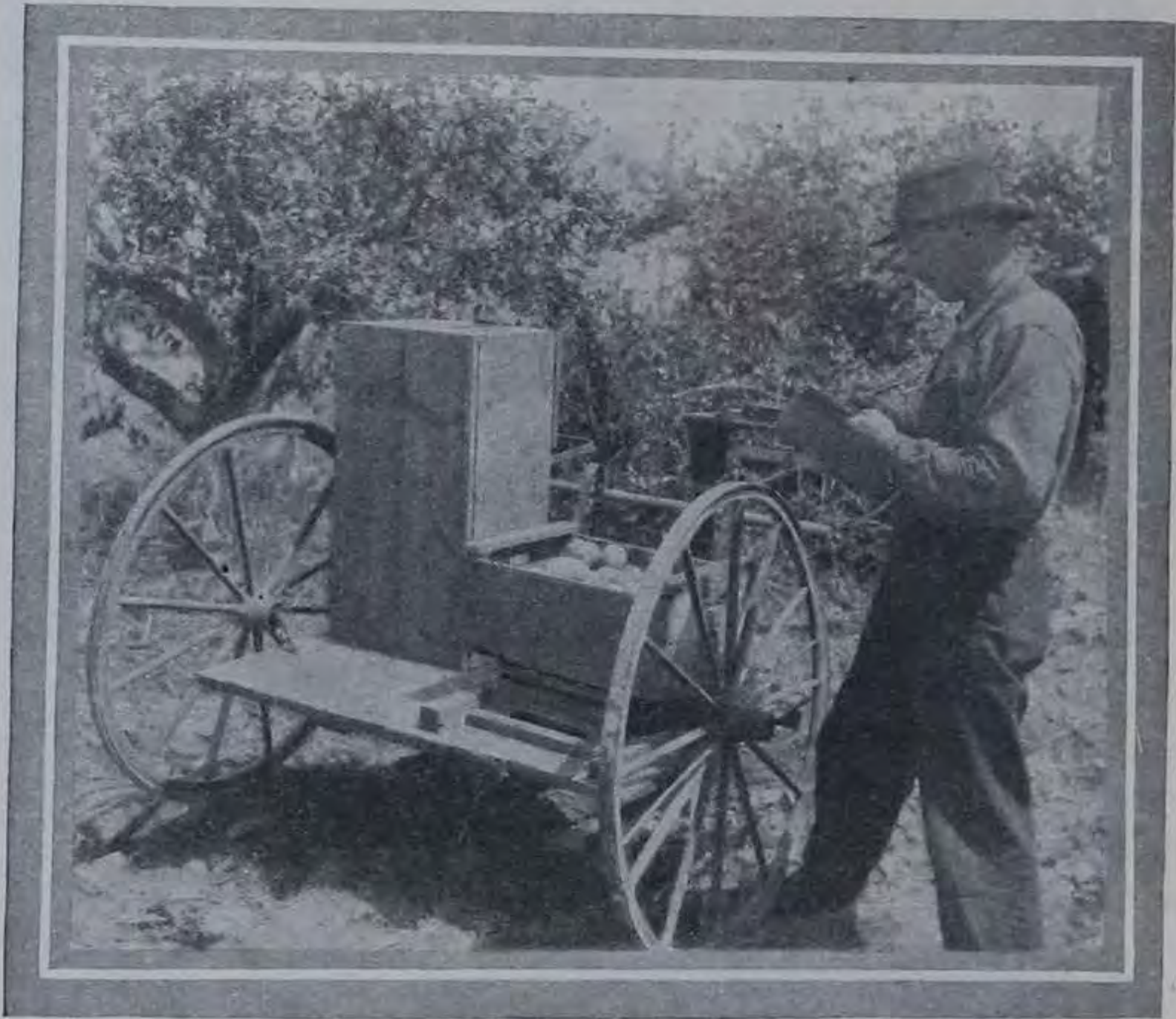

Weighing, an Essential Step.

FIG. 11.—Recording the weight of lemons produced by a Eureka tree at the time of one of the regular monthly pickings. The arrangement of truck and scales is convenient for securing the weight of fruit where this method of keeping individual-tree records is desired.

years has shown that the cost of picking the crops in this way is not much, if any, greater than where the crops are picked in the ordinary manner.

#### RECORDING INDIVIDUAL-TREE PERFORMANCE.

The foreman of the picking crew usually records the individual-tree yields, as shown in figure 11. Each day, after the trees have been picked and before the boxes of fruit are assembled for transporting to the packing house,

or at convenient times during the day, the foreman records in a field notebook the number of boxes picked from each tree. The partly filled boxes are usually recorded as estimated fractional parts of a full box, frequently as eighths. Some growers do not consider this estimate accurate enough and weigh each partly filled box and record its weight of fruits in terms of pounds and ounces.

A convenient and widely used form for recording the yield of each individual tree is as follows:

Variety..... Date.....  
 Block No..... Row No.....

Tree No.	Boxes.	Part boxes.	Quality.	Notes.
1.....	.....	.....	.....	
2.....	.....	.....	.....	
3.....	.....	.....	.....	

If more than one picking is made from each tree, enough additional columns are provided to care for these data.

Where this form is used it is only necessary for the foreman to insert the name of the variety, the date of picking, and the block and row number on each page. Care is taken to look at the tree number each time before recording the data, in order to be sure that no mistake is made.

In addition to the number of boxes of fruit borne by each tree the foreman usually makes a note of the apparent quality of the fruits and of any unusual tree condition. These notes are usually made by means of symbols, as, for example, A, for first grade; B, for second grade; and C, for culls. A tree showing evidences of disease is marked by recording X along with the yield data. Various amplifications of this system are in use in many orchards, and have been found to be of great service in giving the trees individual attention and care.

COOPERATION IN SECURING AND DISTRIBUTING BUD WOOD.

The California Fruit Growers' Exchange, a cooperative organization of about 10,000 members, recognizing the com-

mercial importance of this work, established in May, 1917, a department of bud selection. The work of this department is to secure bud wood from superior performance-record trees and distribute it to propagators. The head of this department is a scientifically trained man, who is familiar with the research which has led up to the introduction of improved methods of securing and propagating reliable citrus bud wood. The object of the work is to put into practice the results of the investigation of this subject by the Bureau of Plant Industry in order to improve the quantity and quality of the citrus production in the State as a whole. It is looked upon by those interested as a public service, both to the producer and to the consumer, and for this reason has the whole-hearted cooperation and support of everyone concerned. This service is performed at cost, and from the beginning has been self-supporting. The operation of this department is briefly outlined in the following paragraphs.

#### THE SELECTION OF SUPERIOR PARENT TREES.

For several years preceding the establishment of the bud-selection department many of the leading citrus growers possessing the best orchards in the State had been keeping individual-tree records of all the trees in their orchards. Some of the largest orchards are approximately 1,500 acres in extent. The tree records of all of these orchards were made available for the work of securing and distributing reliable bud wood. A careful survey was made of these orchards, which are located in every important citrus district in California, and a detailed analysis was made of the individual-tree records of production. The orchards showing the best and most consistent records for each variety and those where the fruit was found to bring the highest market price in its class were selected for more detailed study. Usually three or more years of individual-record keeping were required before any selection of parent trees was made.

In the orchards where the conditions were found to be satisfactory for this work all the highest yielding trees were carefully inspected in connection with their past performance. The type of fruit was carefully examined. The uni-

formity of fruits on all parts of the trees was studied. All trees bearing irregular fruits or those having variable branches were immediately excluded from further consideration. The highest yielding trees which were found to bear uniform fruits of the best type for the variety were selected as sources of bud wood for propagation. In this work the individual-tree records have been found to be invaluable. Experience has shown that an intelligent selection of trees could not have been made without them. In addition to the records and the examination of the trees, their habit of growth, and the characteristics of the foliage and fruits, the selection of parent trees has been guided by an intimate knowledge of the trees of the variety gained through systematic individual-tree record work by those having a natural inclination for it.

KIND OF BUD WOOD.

Only fruit-bearing bud wood is cut from the parent trees for propagation. Usually only those bud sticks are secured which have one or more typical fruits attached, as shown in figure 12. As a rule, 5 large viable buds are obtained on each orange bud stick and 10 strong buds with each lemon bud stick. The buds from this young and somewhat



Fruit-Bearing Orange Bud Wood.

FIG. 12.—Typical fruit-bearing Valencia orange bud stick, showing the type of bud wood secured for propagation.

immature growth have been found, both experimentally and commercially, to give better results in propagation than the buds from older growth or from sucker wood. On the average, 500 good buds are secured from each full-bearing parent tree during a season.

#### HANDLING THE BUD WOOD.

The bud sticks from each parent tree are kept in separate bundles. A tag with a serial number is attached to each bundle. A duplicate tag with the same serial number, the number of the tree from which the buds were cut, and the name of the propagator to whom the buds are to be sent is filed in the bud-selection department. With this information, together with the individual-tree records, it is possible at any time to trace any progeny in a nursery to the parent tree and to examine the performance record of the parent tree for the information of the nurseryman, a prospective purchaser of the progeny trees, or any other interested person.

The leaves of each bud stick are trimmed off immediately after cutting, as shown in figure 13. As soon as all the bud sticks desired are secured from a tree, they are tied in a bundle, tagged, and packed in moist, sterile sphagnum moss. Several bundles of bud wood are usually packed tightly together, and this package is covered with strong burlap. These packages are kept in a cool temperature, preferably about 70° F., until the bud wood is delivered to the propagator. Under these conditions citrus bud wood can be kept safely for several weeks. However, experience has shown that it is desirable to use the buds as soon as possible after cutting them from the parent trees.

#### COST OF THE WOOD.

Inasmuch as the business of securing and distributing these buds is conducted by a cooperative nonprofit organization, the buds are supplied to propagators at cost. At the present time a charge of 5 cents is made for each good bud to members of the cooperative organization or 6 cents for each bud to propagators who are not members of the organization. As soon as the volume of business warrants,

this cost will be reduced. The owners of the trees from which the buds are cut are paid  $1\frac{1}{2}$  cents for each bud secured from their trees.



Fruit-Bearing Lemon Bud Wood.

FIG. 13.—Two typical bud sticks on a superior Eureka lemon parent tree. The leaves have been cut off the one on the right in order to show the method of preparing the bud sticks for packing.

The cost of maintaining this bud-selection department includes the payment for the buds to the owners of the parent trees, the assembling, tabulating, and studying of extensive individual-tree data, the selection of the superior



parent trees, collecting information regularly as to the behavior of the buds and the trees grown from them, and the survey of new orchard areas for the location of additional parent trees. In 1919 an experimental citrus nursery of 7 acres was established for the purpose of trying out different methods of budding, determining the comparative value of different kinds of stocks, and securing other important information for the benefit of the propagators and the growers

#### USES OF SELECTED BUDS.

The buds secured from the superior parent trees are being extensively used by growers for top-working undesirable or drone trees in established orchards or for top-working the trees of one citrus variety with another and by propagators who are growing trees for sale or for their own planting. Up to this time a large proportion of the buds have been sold to nurserymen, who quickly realized the importance of furnishing to planters trees grown from reliable buds. An illustration of nursery trees grown from these buds is shown in figure 14. In fact, under present conditions it is almost impossible for nurserymen in California to sell at any price any other kind of citrus trees. The trees grown from the selected buds sell for a much greater price than the added cost of the buds to the nurserymen. The increasing appreciation by citrus growers of the importance of planting good trees makes it seem certain that the utilization of this work will be greatly increased in the near future.

In the following table the development of the bud-selection service is shown by the number of buds sold each season from the inauguration of this work to date:

*Buds sold from superior parent trees.*

Year and budding season.	Number of buds sold.	Year and budding season.	Number of buds sold.
Season of 1917:		Season of 1919:	
Spring.....	25,550	Spring.....	168,589
Fall.....	82,850	Fall.....	232,187
Season of 1918:		Total.....	754,589
Spring.....	156,455		
Fall.....	88,958		

Out of the total number of buds distributed approximately 75,000 were used for top-working established undesirable trees, and the remainder were used by propagators for propagating nursery trees. These buds were secured from superior parent trees in 21 orchards located in southern California.

During the war comparatively little citrus propagation was carried on. Since the close of the war California nurserymen have planted more than 100 bushels of citrus seed for growing stocks. This recent great activity in stock production indicates that there will be a very largely increased demand for the selected buds for use in budding this stock in the near future.

#### SECURING RELIABLE TREES.

The bud-selection department maintains an office where records are kept of all the available trees for sale that were grown from the selected buds furnished by that department. The parentage of these trees, their condition of growth, and other details are furnished to all inquirers without cost. From these data the planters can intelligently decide where to buy reliable and satisfactory trees. This service is proving to be an invaluable aid to citrus growers.

The widespread membership of the cooperative organization, continually advised as to the progress of the work of bud selection and propagation, has been the most effective way through which this information has been made available to the citrus industry as a whole. The officials of the State University and the United States Department of Agriculture, farm journals, and horticultural clubs have cooperated in bringing this work to the attention of all interested persons. At present there seems to be no good reason why every prospective planter in California should not be able to secure reliable information as to sources of good citrus trees for planting.

#### RESULTS OF BUD SELECTION.

Extensive orchards of all the important commercial varieties, in which the trees were propagated from carefully selected buds secured from superior performance-record

trees, are now in bearing in California. Careful surveys of these orchards have shown without any doubt that they are superior to comparative orchards in which the trees were



Strain Characteristics Revealed in the Nursery Trees.

FIG. 14.—Nursery trees of the best strain of the Eureka lemon variety two years after budding on sour-orange stock. These young trees blossomed and small fruits developed while still in the nursery row. This is characteristic of the young trees propagated by the use of the improved methods described in this article.

propagated without care in bud selection. It is becoming increasingly difficult to find young citrus orchards where the trees were propagated without the use of carefully selected buds. This demonstration of the superiority of the



#### Trees Produced from Selected Buds.

FIG. 15a.—A typical 3-year-old Eureka lemon tree in a large commercial orchard, showing the early production of uniformly good fruits secured from trees propagated from fruit-bearing wood buds selected from superior performance-record parent trees.

FIG. 15b.—A 3-year-old Marsh grapefruit tree in a commercial orchard, showing the heavy production of uniformly desirable fruits developed by trees propagated from selected buds secured from superior performance-record parent trees.

trees grown from buds secured in the manner described in this article has been the compelling force that has made the bud-selection work commercially successful.

The trees grown from the selected buds have shown unusually early production of heavy crops, as shown in figure 15*b*, and are bearing regular crops of uniformly superior quality; in other words, they are producing fruits similar to those borne by the parent trees. This uniformly good production, an example of which is shown in figure 15*a*, has been achieved at no greater cost than the irregular crops having a considerable proportion of fruits of worthless strains, produced by mixed-strain trees, in the ordinary orchard. The uniform fruits on the trees grown from the selected buds reduce the cost of assorting and packing the crops, compared with the ordinary crops. The uniform market grades made possible by the uniformity of fruits increase the confidence of the consumer in the fruit and induce a larger consumption. This condition is economically valuable, both to the producer and to the consumer; it stabilizes the industry as a whole and adds materially to the reputation and value of the crops.

#### COOPERATION AN ESSENTIAL.

The utilization of the results of scientific research in the improvement of citrus fruits through bud selection has largely been made possible through an organized citrus industry. While the investigation of this subject could probably have been carried on without this organization, it was as a matter of fact largely encouraged and fostered by it. In the opinion of the writer the widespread use of the improved methods of bud selection and propagation could not have been so quickly and efficiently introduced commercially in the citrus industry without the active participation of the cooperative growers' organization, the California Fruit Growers' Exchange.

# THE TOLL OF TUBERCULOSIS IN LIVE STOCK



By J. A. KIERNAN and L. B. ERNEST,  
*Tuberculosis Eradication Division, Bureau of Animal Industry.*

THE practicability of eradicating tuberculosis of cattle and swine has been demonstrated in a number of herds in practically every State. Herds which have contained a very high percentage of diseased animals have been freed of tuberculosis by systematic testing and the removal of reactors, and afterwards have been maintained on a healthy basis. Likewise, herds which at the outset of the control work were but slightly affected have been cleaned up and kept as healthy herds.

## RESPONSIBILITY OF OWNERS.

Many owners pay as strict attention to their healthy herds as though tuberculous animals had been found in them. Such owners have had their animals regularly tested and have not permitted animals from outside sources to be brought into the herds until they have been proved free from tuberculosis. This is the proper attitude for the owners of herds to take.

The responsibility for free herds and for keeping them free from tuberculosis rests on the owner and not on the State or Federal authorities. Obviously there is not a sufficient number of State and Federal inspectors to test all the cattle in the United States, nor is it desirable to try to conduct the campaign on that basis. There should be a sufficient corps of State and Federal inspectors to assist the owners in eradicating the disease, but the greater part of the

work should rest on those whom it will benefit most. In practically every section of the United States there are qualified veterinarians who will test cattle with tuberculin and who can advise how to handle the herd so as to free it from the disease or to keep it free.

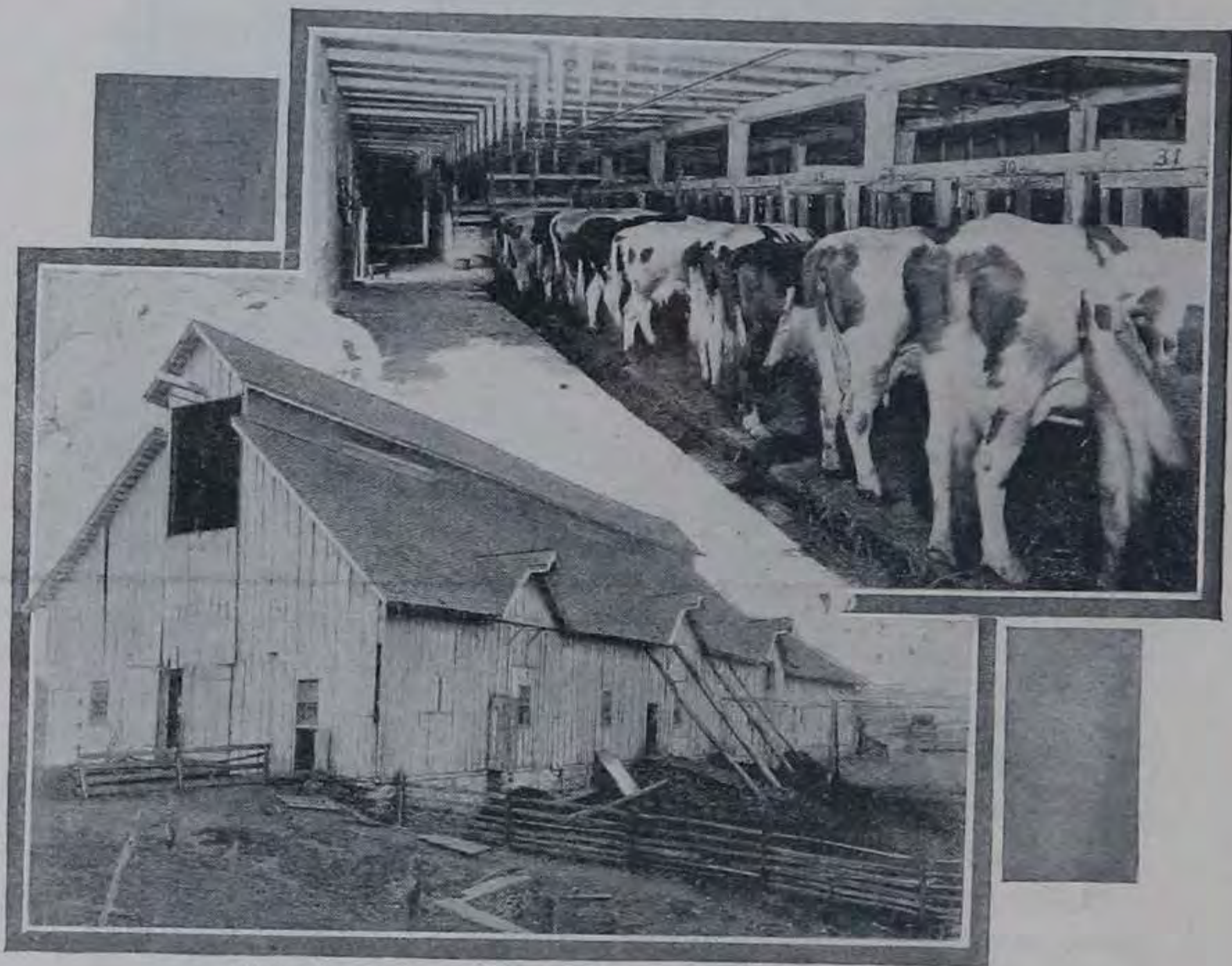

This Barn Housed an 82 Per Cent Tuberculous Herd.

The cattle shown are a number of the reactors obtained as a result of the tuberculin test. Note that the interior is apparently maintained in a sanitary condition. The runways are of concrete but the stalls and gutters were constructed of wood and permitted seepage. The seepage was retained to a depth of about 2 feet. Cattle should never be housed under such insanitary conditions.

#### THE ACCREDITED-HERD PLAN.

The accredited-herd plan, by which owners of tuberculosis-free herds receive State and Federal recognition, has met the approbation of breeders of cattle all over the United States, and it is reasonable to expect that this plan will be followed until most of the purebred herds of the country are under supervision. The accredited-herd plan has been

conducted only in a general campaign, without concentration of effort in any particular locality; but it would be advantageous for a county having a large number of purebred herds to make an effort to have the tuberculin-testing work extended to every herd in the county.

The advantages of such a plan are readily understood. It would call the attention of prospective buyers all over the United States to the possibility of a wider field for choice of purebred cattle in the numerous herds accredited, and there can be no doubt that cattle in such a locality would sell at better prices because buyers would save a great deal of time by not having to look up animals from scattered accredited herds.

FACTS REGARDING LOSSES DUE TO TUBERCULOSIS.

No discussion of a better and larger live-stock industry of the Nation can be complete without consideration of live-stock losses directly attributable to tuberculosis. It is imperative that these losses be reduced. A campaign for the control and eventual eradication of this disease was started in May, 1917, by forming the Tuberculosis Eradication Division of the Bureau of Animal Industry. The results obtained by 2½ years of systematic control effort indicate that there has been an appreciable effect on the losses sustained from the disease.

The records kept by the department show that about 65 per cent of cattle and swine slaughtered in the United States annually are killed at official establishments where Federal meat inspection is maintained. The number of cattle and swine slaughtered at official establishments during the fiscal years 1917, 1918, and 1919 and the number of carcasses condemned on account of tuberculosis were as follows:

*Federally inspected cattle and swine carcasses condemned on account of tuberculosis.*

Fiscal year.	Cattle.			Swine.		
	Slaugh-tered.	Con-demned.	Per cent con-demned.	Slaugh-tered.	Con-demned.	Per cent con-demned.
1917.....	9,299,489	46,351	0.50	40,210,847	76,807	0.19
1918.....	10,938,287	40,792	.37	35,449,247	59,740	.17
1919.....	11,241,991	37,600	.33	44,398,389	65,838	.15



The figures show a noteworthy improvement in the situation, yet the losses from condemnation are still large—much larger than they would be if every owner of cattle and swine were vigilant in combating the disease. It is known also that the per cent of tuberculosis among animals slaughtered at uninspected abattoirs is greater than that at Federally inspected establishments. In addition there are other important though less conspicuous losses. The feed, for instance, given to diseased animals is practically wasted, because when they are slaughtered a considerable percentage of them must be disposed of for purposes other than food.



A Diseased Heifer from a Tuberculous Herd.

While mere physical appearance is not a definite means of judging when an animal is tuberculous, unthrifty condition and a cough are sufficient warning to have the tuberculin test applied.

Besides the condemnation of cattle for tuberculosis at abattoirs, there is each year a considerable number of deaths among mature cattle directly attributable to tuberculosis. Likewise there is a considerable mortality from this disease among calves.

Had the spread of tuberculosis been allowed to continue at the same rate that it progressed from 1907 to 1917, by 1937 the disease would undoubtedly have exacted an annual toll from the live-stock producers of this Nation of one hundred million dollars, and this would have been only a

part of the loss. Our splendid purebred and grade herds of cattle and swine would have been undermined by tuberculosis, and in consequence the reputation of the United States as a producer of high-class cattle and swine would have received an irremovable stigma.

In addition to the losses which can be rather accurately estimated from available records, there is an enormous loss due to this disease which can not be specifically determined. Many herds of cattle from which the owners derive a considerable revenue through the sale of the products are so badly affected that when they are submitted to an official tuberculin test from 50 to 90 per cent of the animals react to the test. The salvage obtained from these animals does not compensate for the loss, because, except in rare instances, cattle known to be diseased can be sold only for immediate slaughter. There is of course a wide difference between the beef price of an animal and its value as a producing or breeding animal. In most States part of this difference is met by indemnities paid the owner through the cooperation of the State and Federal Governments under the accredited-herd plan.

However, the greatest loss in these cases is the loss of the milk and milk products which have been previously a source of income to the owners. The writers know of herds bringing a net profit of from \$600 to \$700 or more per month which were necessarily destroyed by reason of an unusually heavy infection. Such losses as these can not be accurately estimated for the country at large.

The breeder of purebred cattle is in an especially unenviable situation when a large percentage of reactors is found as a result of the test. Among a number of instances known to the bureau is that of a breeder who owned a herd of about 70, and as the result of the test lost 62 head. A majority of these reacting cattle were valued extremely high, but as he had no facilities for maintaining all of them under quarantine, it was necessary that 45 head be sent to a slaughtering establishment. This man estimated his loss at from \$20,000 to \$30,000.

Many instances of serious losses due to tuberculosis occur also in swine. A report was recently received showing that

of 68 hogs shipped from a certain point in Illinois all were affected with the disease, and 33 of them were entirely condemned as unfit for food. Cases of this kind are not unusual.

Finally, the losses react upon the original owners, since most buyers of live stock know the infected areas and offer prices in accordance with that knowledge. In fact, such buyers will purchase animals only subject to a test, when they are from some areas known to be especially heavily infected.

#### HOW TO AVOID SERIOUS LOSSES.

The campaign to eradicate tuberculosis from live stock is now being conducted in 45 States in cooperation with the live-stock owners and the respective State live-stock sanitary officials. Arrangements are being made to have other States engage in the work. However, State and Federal officials can not prevent losses from the disease without the assistance and hearty cooperation of the owners.



A Herd Once Diseased—Now Healthy.

Portion of a herd of 78 cattle, of which 45 per cent were tuberculous in 1913, 16 per cent in 1914, and 12 per cent in 1915. This herd, containing approximately 80 head of cattle, has been found to be free from tuberculosis in subsequent tests.

The first step is for the owner to sign an agreement placing his herd under the joint supervision of the State and the Bureau of Animal Industry for the control of the disease; then skilled operators are detailed to conduct the test. Reacting animals should be promptly removed from the herd and either isolated or immediately slaughtered. Assistance is offered to insure a proper cleaning and disinfection of the premises formerly occupied by diseased cattle. The agreement entered into by the owner entails that he should sub-

mit his herd to a tuberculin test whenever deemed necessary by proper Federal or State officials and that no new cattle should be added to the herd after such tests unless the additions are properly tested and approved by these officials. The tuberculous cow is regarded as being the principal cause of infection in healthy herds; therefore especial care should be taken to purchase cattle only from those herds known to be free from the disease. One owner known to the writers failed to exercise this precaution and it cost him in one and one-half years 82 per cent of his fine grade herd and a revenue of several hundred dollars a month.

#### CLEANING UP AREAS.

The individual efforts of owners to free their herds suggest the thought of entire communities or counties establishing free areas. This work is, in fact, now being taken up. If a county contains, say, 25,000 cattle and 250 of them are tuberculous, why not kill the affected ones and obtain a 100 per cent healthy county? Of course one test will not accomplish such a clean-up, but by a persistent effort a tuberculosis-free county may be attained.

This is proved by the results of the cooperative tuberculosis-eradication work in the District of Columbia. In 1909 the Commissioners of the District promulgated an order requiring a tuberculin test on all cattle within the District and on all intended for movement into this area. As a result of this cooperative work conducted by the Bureau of Animal Industry the per cent of tuberculous cattle has been reduced from 18.87 per cent in 1910 to 0.63 of 1 per cent in 1919, thus establishing an area practically free from the disease. If this area can be made free from the cattle plague, why not all the counties in States where the disease exists to a much more moderate degree than was found at the beginning of the work in the District of Columbia?

In time it will be possible so to reduce any area infected with tuberculosis in live stock that owners will find it unprofitable to keep infected animals or those suspected of being infected with that disease. Experience has shown also that the longer diseased cattle are kept in a herd the greater will be the loss when the clean-up campaign begins.

## METHODS OF TESTING.

The methods employed by the cooperating State and Federal officials include not only the application of the subcutaneous tuberculin test, to be followed by the proper cleaning and disinfection of the premises, but also include, in special cases of badly infected herds, the application of the ophthalmic and intradermal methods of tuberculin testing. The intradermal test can be and is profitably employed on range cattle or others which are difficult to restrain or on animals showing abnormal preliminary temperatures. The ophthalmic test has proved to be especially valuable as a check test and has revealed a considerable number of cases of tuberculosis which had escaped other methods of diagnosis. In its application a disk containing the diagnostic tuberculin is placed in the eye of the animal. If the animal is not diseased no disturbance is indicated, but if infection exists there follows a characteristic formation of pus in the treated eye.

A problem of considerable importance is the tuberculin testing of cattle at public stockyards. Such testing is aimed to check traffic in diseased animals and to protect communities which have little bovine tuberculosis from infection by cattle that are diseased or of doubtful health. This condition applies especially to dairy stock and to breeding cattle, but in preventing interstate movement of tuberculous animals live-stock sanitary officials recognize the need for doing the work in the most expeditious manner.

## BENEFITS DERIVED FROM TUBERCULOSIS-FREE HERDS.

Many inquiries have been made with a view to obtaining reliable information as to the comparative value of cattle known to be free from tuberculosis and those the health of which is not definitely known. Many breeders and live-stock owners will not introduce animals into their herds unless they are reasonably certain that no tuberculosis exists in the herds from which the animals are taken. To such owners an animal of doubtful health has no intrinsic value and they will readily pay a premium for animals from accredited herds. For grade cattle \$10 per head is a conservative estimate of the premium on animals

known to be free from tuberculosis, and \$25 per animal is likewise a reasonable estimate of the premium on purebred cattle. When these figures are applied to the total number of dairy and beef breeding cattle in the United States the reader will recognize the enormous toll imposed by this insidious disease.

It is reasonable to expect that within a few years American breeders will be selling for export many more breeding animals than are being exported at the present time. The degree of success to be attained in the future export trade will depend largely on the class of animals now sold. If a reputation for producing cattle free from tuberculosis and other infectious diseases is established, American breeding stock will be in demand all over the world.

The United States breeders have knowledge of the areas in foreign countries from which it is safe to import animals, and also have information of certain localities and even of numerous herds out of which it would be dangerous to purchase animals on account of tuberculosis. It is only reasonable to expect that precautions based on similar knowledge will be taken by breeders of other countries to protect their live-stock industry from disease. The accredited-herd list of tuberculosis-free herds indicates to the foreign as well as the domestic buyer where he may obtain cattle officially recognized as free from that disease, and the time will come when prospective buyers will be reluctant to make speculative purchases from unlisted herds.

The following table shows the number of herds and the number of cattle in each State under supervision for the control and eradication of tuberculosis. It indicates also the location of inspectors in charge of this work. Owners desiring information on the subject of tuberculosis are requested to write to the inspector in charge of the work in the State in which the cattle are located.

286 *Yearbook of the Department of Agriculture, 1919.*

*Location of Federal inspectors, also number of herds and number of cattle under supervision, August 1, 1919.*

State.	Federal inspector.	Address.	Herds.	Cattle.
Alabama.....	Dr. C. J. Becker.....	1108 Jefferson County Savings Bank, Birmingham.	785	3,285
Arkansas.....	Dr. Joe. H. Bux.....	Old State House, Little Rock..	69	982
Colorado.....	Dr. W. E. Howe.....	444 Post Office Building, Denver	5	186
Connecticut.....	Dr. E. A. Crossman....	2001-2002 Customhouse Building, Boston, Mass.	57	1,508
Delaware.....	Dr. W. G. Middleton...	Statehouse, Trenton, N. J.....	12	626
Florida.....	Dr. J. G. Fish.....	P. O. box 467, Tallahassee.....	402	7,034
Georgia.....	Dr. W. M. MacKellar...	526-529 Federal Building, Atlanta.	434	12,426
Idaho.....	Dr. F. E. Murray.....	326 Federal Building, Salt Lake City, Utah.	15	345
Illinois.....	Dr. J. J. Lintner.....	316 Exchange Building, Union Stock Yards, Chicago.	447	12,285
Indiana.....	Dr. J. E. Gibson.....	33 State House, Indianapolis...	233	5,641
Iowa.....	Dr. F. H. Thompson...	15 Federal Building, Des Moines	323	12,476
Kansas.....	Dr. H. M. Graefe.....	22 Federal Building, Topeka....	164	5,892
Kentucky.....	Dr. W. F. Biles.....	Capitol Building, Frankfort.....	346	5,398
Louisiana.....	Dr. R. W. Tuck.....	323-324 Post Office Building, New Orleans.	253	6,865
Maine.....	Dr. E. A. Crossman....	2001-2002 Customhouse Building, Boston, Mass.	821	10,352
Maryland.....	Dr. T. A. Ladson.....	825 Fidelity Building, Baltimore	324	5,961
Massachusetts....	Dr. E. A. Crossman....	2001-2002 Customhouse Building, Boston.	71	2,117
Michigan.....	Dr. T. S. Rich.....	Old State Block, Lansing.....	216	6,377
Minnesota.....	Dr. W. J. Fretz.....	4-6 Army Building, St. Paul....	1,175	28,933
Mississippi.....	Dr. J. A. Barger.....	605 Millsaps Building, Capital and Roach Streets, Jackson...	1,088	12,286
Missouri.....	Dr. Ralph Graham....	9 Federal Building, Jefferson City.	23	1,078
Montana.....	Dr. Rudolph Snyder...	P. O. box 844, Helena.....	721	12,510
Nebraska.....	Dr. S. E. Cosford.....	332 Federal Building, Lincoln...	139	3,304
Nevada.....	Dr. F. E. Murray.....	326 Federal Building, Salt Lake City, Utah.	4	259
New Hampshire..	Dr. E. A. Crossman....	2001-2002 Customhouse Building, Boston, Mass.	21	834
New Jersey.....	Dr. W. G. Middleton...	Statehouse, Trenton.....	44	2,159
New York.....	Dr. H. B. Leonard....	Care Dr. J. G. Wills, chief veterinarian, Albany.	145	5,508
North Carolina..	Dr. R. E. Brookbank..	418 Lyric Building, Richmond, Va.	651	8,174
North Dakota....	Dr. H. H. Cohenour....	349 Federal Building, Bismarck.	946	15,770
Ohio.....	Dr. L. E. Davis.....	P. O. box 935, Columbus.....	754	15,265
Oklahoma.....	Dr. W. C. Drake, jr....	Department of Agriculture, Capitol Building, Oklahoma.	45	2,281

*Location of Federal inspectors, also number of herds and number of cattle under supervision, August 1, 1919—Continued.*

State.	Federal inspector.	Address.	Herds.	Cattle.
Oregon.....	Dr. S. B. Foster.....	530 Post Office Building, Portland.	139	3,644
Pennsylvania....	Dr. P. E. Quinn.....	P. O. box 327, Harrisburg.....	507	7,914
Rhode Island....	Dr. E. A. Crossman....	2001-2002 Customhouse Building, Boston, Mass.	23	443
South Carolina...	Dr. W. K. Lewis.....	901-902 Liberty National Bank Building, Columbia.	170	6,756
South Dakota....	Dr. J. O. Wilson.....	309 Federal Building, Pierre....	413	5,433
Tennessee.....	Dr. Robert Jay.....	405 Seventh Avenue North, Nashville.	446	10,001
Texas.....	Dr. R. E. Jackson....	606 Flatiron Building, Fort Worth.	.....	.....
Utah.....	Dr. F. E. Murray.....	326 Federal Building, Salt Lake City.	40	1,150
Vermont.....	Dr. A. J. De Fosset....	Care Commissioner of Agriculture, Montpelier.	430	12,677
Virginia.....	Dr. R. E. Brookbank..	418 Lyric Building, Richmond.	1,038	27,021
Washington.....	Dr. S. B. Foster.....	530 Post Office Building, Portland, Oreg.	113	3,560
West Virginia....	Dr. G. W. Neff.....	Care Commissioner of Agriculture, Charleston.	97	1,893
Wisconsin.....	Dr. J. S. Healy.....	11 East Wing, State Capitol, Madison.	550	15,392
Wyoming.....	Dr. W. E. Howe.....	444 Post Office Building, Denver, Colo.	3	62

As the number of herds that can be taken under official supervision for the eradication of tuberculosis at present is limited, it is recommended that cattle owners obtain all the information they can respecting this disease and, if they have reason to believe that it exists in their herds, they should employ measures to exterminate it regardless of the fact that an official can not be obtained to assist them. It is of economic importance that each owner be responsible for the health of his herd. Live-stock owners also may be of great immediate assistance in tuberculosis-eradication work, with much benefit to themselves, if they will isolate all animals brought into their herds until such animals are definitely known to be healthy, and will maintain clean and sanitary surroundings.

The gradual increase in the number of live stock in the United States and in the shipment and exchange of animals makes disease control and eradication a problem demanding



the closest cooperation among live-stock owners, sanitary officials, and the public in general. The regulations which have been found necessary are directed at a small minority of conscienceless people who, if unrestrained, would spread disease all over the country. In addition many of the provisions regarding the handling of live stock in interstate traffic are a check on carelessness or indifference to public welfare. It is believed that the great majority of live-stock men, knowing these facts, will support regulations which are intended to correct the conditions.

#### TUBERCULOSIS IN SWINE.

Eradicating tuberculosis from cattle will practically solve the problem of controlling the disease among swine. That is the opinion of veterinary experts experienced in the handling and post-mortem examination of swine received at the principal market centers. By means of a simple and practical marker, hogs may be tattooed with distinguishing letters and figures, and when disease is found by post-mortem examination the identity of such animals is known. With a simple system of records it is thus possible to trace a shipment to the farm from which it came and stamp out infectious diseases at their source. Evidence shows that swine become infected with tuberculosis principally from cattle, either by following them in feed lots or pastures, by receiving infected dairy by-products, or by eating tuberculous carcasses.

# The REORGANIZATION *of the* COUNTRY SCHOOL



By ALVIN DILLE,

*Specialist in Agricultural Education, States Relations Service.*

THE World War brought to the attention of the people of the United States one of the weaknesses in our system of education, that more than one-half our 6,000,000 illiterate adults live in rural sections where the school facilities are poor.

Further, the reports of the Commissioner of Education show that about one-half of the school children of the nation are enrolled in village and country schools, and that these children are laboring under distinct educational disadvantages. Fully 200,000 of the schools of the open country may still be classed as one-room schools of pioneer type, which, at their best, meet but poorly the needs of modern agricultural communities.

“The little red schoolhouse” of bygone days played so prominent a part in pioneer life, that it has been praised in song and in story and has won for itself a place in the hearts of the country people. It had a unique setting, was peculiarly an American institution, and was a distinct part of pioneer life. A belief in the almost magic efficiency of the rural school offers a real stumbling block to those who would have this school keep pace with the changes in the world around it. While we may justly be proud of this little one-room school, we are apt to forget that the basis for our pride is the fact that we still keep some kind of a school, and not the fact that this school is so good in itself. The question that we must ask of all our schools, both city and country, is not whether they did what they could for our grandfathers,

but whether they are doing to-day all that we want them to do for our children? We should not ask if they have produced great men, but whether they help the common man to make and use his opportunities and to strive with a steady purpose. It is necessary that the country school should do this, for on it rests the burden of the prosperity of the entire country. Unless the nation has a body of enlightened and

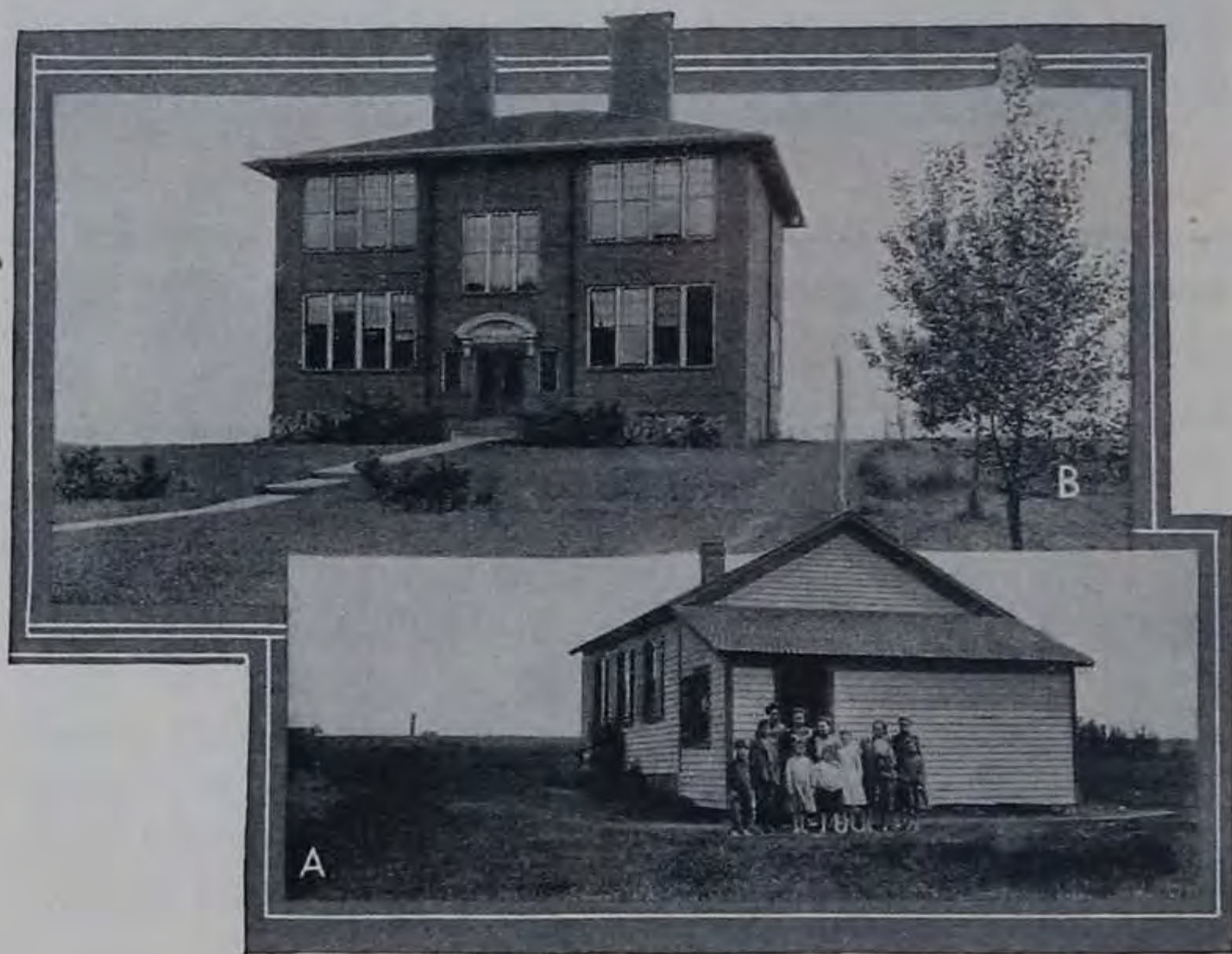

The Old and the New.

A. The old—a type of one-room school failing to meet the educational needs of the community. B. The modern rural school consolidated—a school for the entire community, young and old.

ambitious farmers, keeping their own farms from generation to generation, agriculture can not flourish and the nation can not prosper.

The social, economic, and industrial changes of the last 50 years have been great. Progress in farming methods has been so rapid of late that many have failed to keep up with it or to grasp its bearing upon society.

With the introduction of labor-saving farm machinery and corresponding strides in the cheap and rapid production of foods and other farm products, significant readjustments have taken place. The absolute inadequacy of the rural

school to meet these new educational and social needs is evident to any one who has studied the problem. The great change in agricultural methods and the great increase in scientific knowledge relating to agricultural processes have created a new body of knowledge of fundamental importance to country people. New standards in education have been created and new demands have been made upon the school, which the school has been very slow to meet. The result of the many changes in rural life is that the rural school has lost its earlier importance and finds itself inadequate to respond to the demands made upon it. Nothing short of a reorganization of the rural school along good educational and administrative lines will meet the needs of the present and the future.

#### STANDARDS OF REORGANIZATION.

Dr. Dewey well expresses the mission of the public school when he says: "What the best and wisest parent wants for his own child, that must the community want for all its children. Any other ideal for our schools is narrow and unlovely."

The country boy and girl are entitled to just as good an education as their city cousins, and until this is given them rural education does not measure up to its proper requirement. If the American farmer expects to play his part in the program for reconstruction and reform he must provide an education for himself and his children that shall fit them both for the task. Never before has the need for the training of the rural population been so urgent as to-day, and never before has the demand for a new rural school been so clearly defined. This does not mean that the country child should receive a fundamentally different education from the child who expects later to work in a mine or teach school, but it does mean that the country child has as much right as the city child to a training which will enable him to live in the world in which he finds himself and understand his share in it, and to get a good start in adapting himself to it. It is the business of every school to train its pupils to be successful as human beings and as American citizens. To do this it must take into account and make use of the conditions around it—the interests, the needs, and the occupations of

the families of its pupils. This does not mean that our rural schools shall be a copy of the city schools, but that there shall be set up in every rural community a school which will base its work upon the life of the community and the needs of the community, so that its pupils shall receive the necessary training that will enable them to fit successfully into the life of the community. The great function of this school will be to furnish the boy with the particular knowledge required for the life that he is to live, for knowledge lies at the basis of his efficiency. It must shape the attitude of the pupil so that he will meet his part of the world's work or its play in the right spirit. It must not leave him a parasite, ready to prey upon others, but must make him willing and glad to do his share. Finally, the school must give him the individual training in technique or the skill required in his different activities; not to do this in the best way possible is to leave him a well-intentioned and well-informed bungler, falling far short of efficiency.

The means by which the school is to accomplish these ends are: (1) The social organization of the school, or the life and activities that go on in the school from day to day; (2) the curriculum, or the subject matter which the child is expected to master; and (3) the instruction or the work of the teacher in helping the pupils to master the subject matter and adjust themselves to the organization of the school. These factors will necessarily differ according to the particular type of the school in question, but in general the social organization of the rural school will center in the life of the rural community; the course of study should center in the one occupation of common interest, agriculture, and the teacher's instruction and guidance should focus upon improving rural conditions in general and bettering the farm practices of the district. The school is the best and most available center for the upbuilding of the country community and should become the most immediate and effective local agency in the solution of the farm problems. The rural school must become a real part of the active life of the community; it can not afford to go its own way, isolating and shutting off all outside influences. In view of the present conditions prevalent in the rural school, what are some of the most urgent

deficiencies and how shall they be supplied in the reorganization which must come about if the school is to function properly?

#### EDUCATIONAL REDIRECTION.

What we need and what we must have to solve the problem of rural education is not a city school whose influences lead young people of the farms directly away from the land, but a country school, improved, modernized, and adapted to the needs of present country life; a school whose atmosphere is distinctly rural, whose teachers are rural minded and in full sympathy and harmony with farm life and farm problems, but no less well-trained and cultured than city teachers. It means a larger school, in the sense of a larger enrollment and of serving a larger territory than the little one-room school served. It means the employment of enough teachers to give ample time for instruction and recitation in every class and affording suitable grading and classification for all pupils. It means an enlargement and enrichment of the course of study which will give the best development of the present conception of modern education—the adjustment of the individual to his environment. While the basic subjects taught in the rural school will not and should not differ greatly from those taught in the city school, they must be made more applicable to farm life. Much of the old course may be eliminated entirely, and in the remaining studies the emphasis must be shifted to the vital and practical interests of everyday life. The rural school, therefore, must teach the basic subjects that belong to all culture—that every normal intelligent person should study just because he belongs to the twentieth century civilization—and in addition the subjects that give him the knowledge, the attitude, and the technique belonging to the life on the farm.

#### THE COURSE OF STUDY.

This curriculum, briefly, may be outlined as follows:

*Language.*—Mastery of the English language is the birth-right of every child. First of all he should be able to speak it correctly and with ease. Next he should be able to read it understandingly and with enjoyment, and should become familiar with the best in its literature. He should be able

to write it easily, with correct spelling and good composition. Finally, he should know something of the structure, or grammar, of the language, though formal grammar is of little value in the learning of a language. The proper substitute for a grammar is live language lessons dealing with familiar objects, scenes, stories, and experiences within the pupil's comprehension and knowledge. In addition the child must learn to read, not only to pronounce the printed words of a page, but to grasp the thought and feeling and to express them in oral reading. The present rural school course in reading is wholly inadequate, and as a result most rural school children seldom attain such skill and taste in reading that it becomes a pleasure. This must be remedied, not only by teaching the child the mechanics of reading, but by leading him to read and love good books. This can only be done by supplying the books and giving him an opportunity to read them.

*Arithmetic.*—Without doubt number is an essential part of the child's education. Yet there is nothing so magical about the mere art of numbering things that should make arithmetic require so large a proportion of the time as it is now receiving. By a wise choice of material, eliminating the "useless lumber" found in most arithmetic texts, it is altogether probable that the child can learn in half or two-thirds the time ordinarily allotted all the arithmetic needed, not only for practical use, but also for mental development in the mastery of arithmetic.

*History and civics.*—The study of history instills into the minds of our children love of country and of liberty, and should therefore receive careful consideration. It should not deal chiefly with wars and politics. The meat of the subject is the big, stirring events that influence the lives, deeds, and aspirations of individuals. The child should know about the people of his country, their home life; their industries; their schools and churches; their bravery; their hardships and adventures. He must come to know something of all the great men of the nation. In civics the great problem is to influence conduct in the direction of upright citizenship and to secure such a knowledge of the machinery of government as will lead to efficient participation in its activities.

*Geography.*—The country is the most appropriate place for the teaching of geography and nature study, because an abundance of material lies right outside the door of the school. Geography, therefore, can be made one of the most vital and useful branches in the rural school. It is to begin wherever the life of the child touches nature in his immediate environment and proceed from this to other parts of his home land and finally to all lands. The intimate interrelations existing between geography and such subjects as agriculture, history, language, and natural sciences are obvious.

*Health and hygiene.*—Health is at the basis of all success and happiness, and no subject can be more important in the education of the child than practical hygiene. This course should emphasize the laws of hygiene, but with particular bearing on right living under the conditions imposed by the farm. Food and clothing; work, recreation, and play; care of the eyes and teeth; bathing; ventilation of the home, especially of the bedrooms; danger of contamination to water and milk supply; childhood afflictions like adenoids, diseased tonsils, measles, and the like—these are some of the practical topics that every child should study. But we must go one step further; this subject must be presented so effectively and so concretely that it will lead to better habits of living.

*Agriculture.*—Agriculture, of course, is a preeminent subject for the rural school; it is of immediate practical importance and is also so useful a cultural subject that it is being introduced into many city schools. Rural life centers about the country home and in the one big industry, agriculture. The farmer's great, vital problem is how to make his country home the happiest and best possible place to live in and how to make agriculture profitable, enjoyable, and capable of supporting the right kind of home. That for this reason agriculture is the logical subject around which to build the rural school curriculum is self-evident. The question is, What should the study of agriculture embrace and how should the other subjects correlate with it?

It is possible to give children in the rural elementary school much useful information concerning agriculture, even if it can not be taught to them as a science. Perhaps it is possible to develop a scientific attitude and interest that will



lead to further study of the subject in high school and college and that will in the meantime serve to attach the boys and girls to the farm.

To begin with, a strong course of nature study should run through the grades and blend into the formal intensive study of agriculture in the last two grades of the elementary school and the rural high school. The particular mission



Practical Instructions in Agriculture.  
A class in stock judging in a rural school.

of this nature study is to open the eyes and minds of the pupils to the wonders of their environment and to the opportunity for first-hand observation and lessons in soils, plant and animal life, and a host of natural phenomena with which they daily come in contact. To supplement the work of the school and make it directly applicable to the child's home life, the planting and care of plants, bird study and protec-

tion, home gardening, weed control, insect and plant disease control, and similar activities fall within this scope.

It is agreed by all teachers of agriculture that instruction in this subject shall follow as far as possible the following lines: (1) It shall be seasonal, that is, the subject matter relating to the farm practice of the district can be best taught at the season when these practices are being carried out on the farm; (2) it shall be practical; and (3) it shall be related directly to the life of the community and the instruction shall center in the lines of community endeavor in which the majority of the farmers are engaged, or which may be especially adapted to the locality. To this end the pupils can be made familiar with the best methods of planting, cultivating, and harvesting the various crops; and with the plant diseases and insect enemies which affect them; with seed selection; rotation of crops; soils and soil management; the growing of fruits and vegetables; and many other practical things applying directly to farm life. In a like manner the animals of the farm may be studied and a knowledge gained of the best breeds and types of farm animals, their breeding and care, and the handling and disposal of the animal products of the farm. Both laboratory and field work should be made prominent throughout the course. In order that the principles taught in the school may be carried out in farm practice, the pupils should be encouraged to undertake "home projects," such as keeping a garden, caring for a cow, or growing chickens. Their instruction at school should center about their projects. The project should be carried out on a business basis; should be carefully planned and worked out under as close supervision as possible, and be conducted with the view of showing a money profit at its completion. Aside from the value to the pupil as farm practice, it has also the educative value as a management project and carrying to its finish a definitely planned enterprise.

*Home economics.*—While the country girls, like the country boys, should have good training in the elements of agriculture, the distinctive field of the girls along industrial lines lies in the art of home making, embracing such branches as cooking, sewing, care of the sick, home planning, and home management. These subjects can be presented successfully in a concrete and applied form, and nothing could

be more vital to the interests and welfare of the girls. To furnish the proper facilities for this work a well-equipped department is necessary. While it need not be elaborate or expensive, yet it should at least be on a par with the facilities found in the better equipped farm homes, and may even be somewhat in advance of them, in order to impress upon the community the need of lightening the burdens of the



Applied Home Economics.  
Serving a hot lunch in a rural school.

average farm home. The farm kitchen deserves to share more generally in the labor-saving devices so commonly found outside the home, but too frequently not appreciated inside of it.

*Farm shopwork.*—The modern farm, with its variety of machinery, tools, special types of buildings, drainage systems, concrete construction, and the like, taxes the ingenuity of the farmer to keep things in proper repair and calls for a deftness of hand and no end of originality and self-confidence. Therefore a thorough course in farm shopwork in the rural school is indispensable. The work attempted may cover the use of tools, the finishing of different kinds of woods, rope tying and splicing, the care and sharpening of

farm tools, harness and leather work, concrete construction, the elements of blacksmithing, and the making of ordinary repairs on buildings. The older boys may branch out into project work and construct chicken coops and brooders, seed-corn racks, feeding racks for stock, wagon boxes, self-feeders for poultry and hogs, home furniture, and similar articles commonly found on a farm. This list is merely suggestive and will vary with the school or the community and with the season of the year.

*Physical training, games, and play.*—Because of its isolation and independence, country life has greater need of play and recreation than city life. Most rural schools have been too small to get enough children of corresponding ages together for interesting games or sports, and again many think that the rural child has enough exercise and does not need the physical training that comes from plays and games. Certain forms of farm work done by children are often so severe a tax on their strength that a corrective exercise is necessary to save stooped forms, curved spines, and hollow chests. Furthermore, the farm child, lacking the opportunities of the city child for gaining social ease and control, needs the development that comes from physical training to give poise, ease of bearing, and grace of movement. Some of the worth-while and suitable country plays and games are suggested: (1) The common folk and children's games at school led and supervised by the teachers; (2) baseball, basket ball, volley ball, track work, and similar games of skill and competition; and (3) play festivals, pageants, picnics, harvest home, community singing, bands and orchestras, debating and literary societies.

The main features of the curriculum here proposed are so much broader and richer than are offered by the present rural school that it will appear to many as visionary and impossible. That it is impossible for the old type of rural school is readily admitted, but it is entirely practicable and possible in the reorganized school and is being successfully presented, in general at least, in many of these schools.

#### PHYSICAL IMPROVEMENT.

The program of studies outlined above does not contemplate their being carried out in the present poorly equipped,

one-room, one-teacher rural school. The broadening of the curriculum presupposes better physical equipment for the rural schools. As they exist to-day the rural schools have inadequate buildings and equipment. The building is usually located in a barren spot of ground and is constructed without any reference to architectural effect. Of the plain "box-car" type, no attempt is made to decorate the room or to relieve in any way its ugliness and monotony. If there is a library it may contain only a few dozen volumes, poorly selected and often without any case for protection. Of equipment outside of desks and blackboard there is almost none. The work of the farms about it is done with modern and efficient machinery, but the work of the farmer's school is done with inadequate and out-of-date equipment. The greatest advantages of improved physical equipment in the reorganized rural school are to be derived from the abandonment of two or more of the one-room schools, depending upon size of districts and enrollments, and erecting in their stead a single building large enough not only to accommodate the present enrollment but also to serve the community for years after its erection. It goes without saying that these buildings should be constructed of durable material and that they should be attractive, safe, sanitary, and in keeping with the highest community ideals. Whatever the size or kind of school building a district may be planning to build there is wisdom in making it conform to the "unit plan of construction." This takes into account both the present and the future needs of the district, requires a symmetrical design for the complete building, and allows for additions at a minimum cost without disturbing the part originally constructed.

In general every school building that accommodates one hundred or more pupils should provide for the following: (1) A suitable auditorium with a stage, a good stereopticon, and, if possible, a moving picture machine; (2) a home economics laboratory with a lunch room adjoining; (3) a gymnasium with shower baths and lavatories for both sexes; (4) a well-equipped laboratory and classrooms for science and agriculture; (5) a well-equipped room for farm shopwork. It is usually possible, and often advisable, to have one room serve for gymnasium and auditorium, and this should be

freely used for all kinds of school and community gatherings. Too much emphasis can not be laid upon this all-important community-center auditorium. The agricultural department and laboratory should be opened as freely to farmers for consultation as for class instruction during school hours, and in the matter of such work as seed corn testing, germination and purity tests of grass seeds and grains, grafting and care of fruit trees, feeding rations, and the like, the work should supplement the actual work on the neighboring farms. The same may be said with equal force of the farm shopwork of the boys and the home economics of the girls. Should this new school fail to make its industrial work for both boys and girls distinctly practical and directly applicable to actual farm conditions, it would fail in one of the fundamental purposes for which it was created.

In every way possible the further construction and equipment of the school should be modern and sanitary; ample land should be provided not only for demonstration purposes in teaching agriculture, but also for the games and plays necessary; and this playground should be simply equipped with playground apparatus for children of various ages.

#### THE THREE MILLSTONES ABOUT THE NECK OF RURAL SCHOOL PROGRESS.

(1) Absence of real professional supervision, (2) insufficient revenue, associated with the too small district unit of taxation, and (3) the untrained teacher—of these evils the first two are the natural result of the way in which our rural-school system was evolved in the settlement and agricultural development of the country. If the rural school is to come into its own, both organization and supervision must be changed, and with the coming of effective supervision the untrained teacher would quickly disappear. A sufficient revenue is absolutely fundamental to rural school improvement. Good teaching, modern buildings, ample equipment, efficient supervision, all cost money—more money than country people are often willing to pay. As a rule farmers usually raise but a small fraction of the amount they might legally levy for school purposes. Rural school penury is

almost proverbial. About \$33 is expended annually for the education of the city child, while for each country child but \$13 is used. Until this inequality is remedied the lack of revenue will remain a fundamental difficulty with the rural school.

It is fundamental that the State should share with the local community the support of the rural school. The cities are dependent upon the farms for much of their wealth, and it is but fair that they should help in the education of the country children, since any agency that improves rural conditions contributes to the welfare of the city. Many States contain sparsely settled localities that are unable to raise sufficient funds to support an efficient school, and these communities especially should receive the help of the State. Perhaps the unwillingness of the farmer to support his school better is due to the fact that he does not realize adequate returns. In localities where the reorganized school is in operation the financial support is adequate and given cheerfully.

The reorganization of the rural schools is leading directly away from the one-teacher school, and the factors necessary for reorganization can not be found in the one-room school. Educationally the graded system gives the rural children all the advantages of the city children. Three or four teachers working together, doing the work formerly done by one, can do greater justice to the children under their charge. Redirected teaching and vitalized courses of study can then become a reality. This and the ultimate fulfillment of such a course through a good high school make the new system the adequate solution of the rural school problem.

These results can best be attained by uniting several districts into one and erecting a building adequate for the new work. Consolidation of the country schools, therefore, is the best way by which this reorganization may be brought about.

For many localities, of course, consolidation is impossible, and for the children of these districts the one-room school must continue to serve. Good teaching may be done in these schools by well-trained teachers, who are themselves of the country, are acquainted with country life, and in sympathy with rural ideals.

In many small one-room schools throughout the country these devoted teachers are found, and, in spite of many handicaps, they are successfully adapting the work to the community needs, and are giving the boys and girls a useful type of training. If a district should find consolidation impracticable and well-nigh impossible, attention should be directed to the improvement of the small one-room school, with the purpose of making it stand truly for rural life and rural education.

#### CONSOLIDATION THE BEST MEANS OF SECURING EFFECTIVE REORGANIZATION.

In the matter of material equipment the weakness of the district system of organization manifests itself clearly. In some places the little district school, because of its remoteness and of scanty population, must for a time at least remain as it is. In many other regions, though, there is no business or educational reason for the continuation of so many small and relatively expensive schools. The needs of rural people could be much better served, much better schools for their children could be provided, and not infrequently a financial economy could be effected if the long-outgrown district system were in a large measure superseded by a more rational and more business-like system of consolidated schools. Such a reorganization must be effected before much progress can be made in redirecting and revitalizing rural education.

Some of the advantages of the consolidated school to which the children are carried in conveyances may be mentioned briefly, as brought out by experience: (1) Both the enrollment and the attendance for the area consolidated are materially increased. This is particularly true of the upper grammar grades. (2) Tardiness is practically eliminated and absences are reduced to a minimum. (3) Pupils arrive dry and warm each day, with no wet clothing to be dried; colds and other troubles, due to exposure, are materially reduced. (4) The pupils are under care of a responsible person coming to school and going home. Quarreling, smoking, profanity, vulgar and improper language are prevented. (5) Better grading and classification is possible; classes are large enough to stimulate enthusiasm and gen-



erous rivalry; pupils can be placed where they can work to best advantage; interest, enthusiasm, and confidence come from contact with numbers. (6) The grading of pupils and the assembling of a large group of children make possible the rural high school, with a vital course of study fitting into the redirected elementary course, affording the rural children an opportunity for studying in a broader sense, with an enlarged vision, those fundamental subjects necessary to a richer country life. This makes possible the slogan of the twentieth century, "A high school within reach of every rural boy and girl." (7) All the advantages

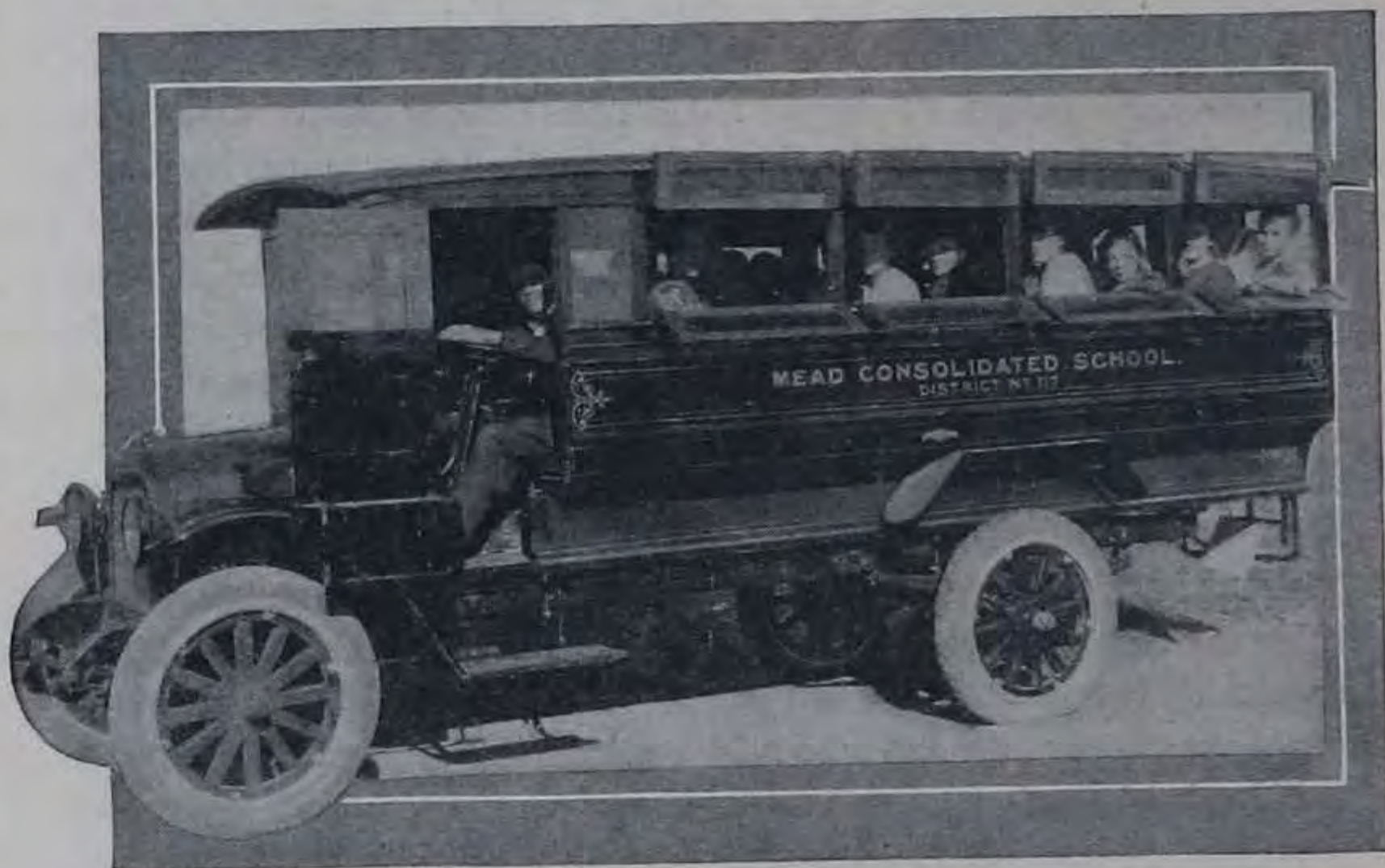

Going to School a Pleasure.

A modern autobus carrying school children to the consolidated rural school. of better school buildings and sites and better equipment follow this consolidation plan, and often cost less per capita than the much inferior equipment of small and scattered schools. (8) It leads to a school term of eight or nine months, instead of the five or six months commonly provided for in the district schools; to the employment and retention of better teachers; to better supervision for the school; and to a higher grade of instruction. (9) Community interest in education is quickened and community pride in the school is awakened. This leads to community interest as opposed to district interest; tends to break down the isolation and

stagnation of rural communities; and leads to a deeper sympathy and better fellowship among the people. It improves the community as well as the school, and opens the way for such a school to become a center for all the better life of the community. (10) It offers to the rural boys and girls, and hence to country parents, all of the desirable educational features and advantages which the city boys and girls now obtain without obliging them to go to the city to obtain them. (11) The transportation feature indirectly aids in the building of better roads, which in turn make rural life more attractive and help to break up the isolation of the country home. (12) In reducing the number of teachers needed it eliminates many of the poorest and weakest and also reduces by from 60 to 80 per cent the number of trustees needed to manage the schools. Both of these are gains of much importance. (13) Such a school with its modern equipment and enlarged and vitalized course of study, together with the high-school advantages, makes possible the extension of its influences throughout the entire community through varied activities which touch the farm and farm home through courses in agriculture and home making. (14) The school becomes the community center for this new district. Here the various educational activities center. Through special courses offered for the farmer and his wife, the educational opportunities are placed before everyone in the district. The school becomes truly a center of influence touching the life of every part of the community, and by making its instruction center about the needs of the community, its life and interests, justifies itself as the really adequate "college of the people."

Miss Mabel Carney writes in her book "Country Life and the Country School," "The great adaptability of the good consolidated country school for community service and rural life regeneration can not be too strongly emphasized. Wherever it has been established, in practically every instance on record, this attribute has been illustrated. The consolidated school builds up the community as no other institution of rural life has yet done. It even defines community boundaries and establishes a community sense where none has existed before. It overcomes petty jealousies, swallows small differences, and enlarges and intensifies the

community idea into something significant and tangible. It brings neighbors on opposite sides of the hill together, introduces those who live on different roads, forces the civil meeting of families that 'haven't spoken since the war,' and in every way furthers the progress of the brotherhood of man among farmers."

Finally, the consolidated school is the most economical system of rural education. The better social and educational benefits it yields are the guarantee of its value. Considering its social, educational, leadership, and financial aspects, consolidation of rural schools is the best educational system and offers the largest prospects as a means of community improvement. It will be a center of community pride and effort for those beyond school age as well as for children. To it will turn the old man and the little child, the mother, and the father. The young people of the community will seek its doors. Its instruction will be in terms of daily living and present activity. The spirit of this instruction will go out through all the country and find expression in better homes, better churches, strong, rightly directed farm organizations, good roads, and greater crop yields; in better business, better farming, and in a happier people and a more satisfying country life.

# COMMON SENSE IN POULTRY KEEPING



By ROB R. SLOCUM,

*Poultryman, Animal Husbandry Division,  
Bureau of Animal Industry.*

A WIDE DIVERSITY of methods is found in poultry keeping. Rations are fed varying all the way from those of the utmost simplicity to those which are decidedly complicated. Houses are used which differ widely in their general plan of construction. Methods of management in use are widely divergent in many cases, and this diversification frequently creates the idea that the care of poultry, and especially the farm poultry flock, is a highly complicated matter. Actually, however, this is not the case. The mere fact that success is attained under widely different methods of feeding, housing, and management indicates that so long as certain fundamentals are observed the actual details or methods may be very different without materially affecting the results. Where poultry is kept as a specialized business it well repays the owner to study these details of management for the purpose of securing the very highest possible return from his hens. So far as the farm flock is concerned, where the farmer is not a specialist



A Mongrel Flock.

Great variation in type and color. The product from such a flock will lack uniformity and will not market to the best advantage.

along poultry lines, good results will be obtained if the underlying fundamentals of successful poultry keeping are observed. It is a thorough understanding of these fundamentals which is especially needed in connection with the farm flocks. Farmers can hardly be expected to concern themselves particularly with the less fundamental and more specialized phases of the business. But it must not be understood from this, however, that the flock may be neglected and good results still obtained.

Success with the farm poultry flock depends, therefore, under usual conditions, on the observance of the fundamentals underlying successful poultry keeping, and this means doing a relatively few things in the right way and doing them at the right time. The place of poultry on the general farm must be definitely understood. It must be remembered that the poultry flock is merely one of the activities with which the farmer is engaged and that he will be unable to devote to his flock a great amount of time. The part which poultry should play, therefore, is to fit into the general farm management in such way as to help maintain a proper balance in farm operations and to utilize materials which are suitable for feeding the hens but otherwise would be wasted.

#### GOOD STOCK STIMULATES INTEREST.

The first fundamental of successful farm poultry keeping is good stock. Of course it is well known that farmers may at times get fairly good results from ordinary stock, but at



A Flock of Standardbred  
Barred Plymouth Rocks.

Such a flock requires no more feed, care, or room than a mongrel flock, but the product will be much more uniform and will market to better advantage. Who wouldn't take pride in a flock like this?

the same time it must be remembered that with the same care and attention better results will be obtained from good stock. By good stock is not necessarily meant stock which has been bred for exhibition purposes. It means standardbred stock or purebred stock, which by virtue of its pure breeding has been systematically developed and which is better fitted, therefore, to give the results expected of it and to yield a more uniform and more desirable product.

On the average farm the poultry flock is expected to furnish eggs and poultry for the farmer's table as well as to produce a surplus for sale. For that reason it is usually found that the so-called general-purpose breeds, such as the Plymouth Rock, Wyandotte, Rhode Island Red, and Orpington, which are good layers and at the same time make suitable carcasses for the table, are best suited to the

farm needs. A further advantage of good stock is the fact that the owner will take a pride in such a flock which he will not feel in a flock of mongrels, and as a result he will give the hens better care.

#### SELECTION OF BREEDING STOCK.

The selection of the breeding stock is important. In most farm flocks no trap nesting or pedigree breeding is possible on account of the labor and time involved, but if careful attention is given to the selection of breeders, advances may be made. It is much better to select from the flock as many of the very best individuals as are needed to make up the breeding pen rather than to breed from the flock indiscriminately. The principal basis of selection of these breeders should be along the lines of vigor. Be sure that the breeders show every evidence of health, vigor, and stamina.

#### HOW CULLING IMPROVES THE FLOCK.

In every flock there will be found a great difference in the productivity or egg-laying ability of the various individuals. While some hens will prove to be very profitable, others are kept at a loss and are a drag upon the profitable hens in the flock. It is important, therefore, to cull out the unprofitable producers, as this will increase materially the profit realized from the flock as a whole. Any hens found to be sickly or in poor condition should be culled as soon as discovered. In addition, at least one thorough culling should be made, preferably between August 15 and September 15. At that



A Profitable Hen.

She produced 160 eggs in a year.



time each hen should be handled and carefully examined, and those which show evidences of laying should be retained, while those which have stopped laying and begun to molt should be discarded from the flock for the following year. A further examination of the hens late in October or early in November will enable one to pick out those which are still laying, and by virtue of that fact are probably the best layers of the flock, and should be selected as breeders.

#### JUDGING THE SIZE OF FLOCK.

A suitable size of flock for the particular farm in question and for the kind of farming which is being carried on is an important factor in securing the best possible results. As long as the farm flock is intended as an agency for utilizing waste it should not be so large that the waste products available on the farm play a very small part in sustaining the hens. Practically any farm of average size can maintain to advantage a flock of 100 laying hens, and many farms can maintain considerably more. Judgment must be used with regard to the size of the flock on the basis of feed available and the range over which the hens can roam and pick up feed for themselves.

The size of the flock also has a direct connection with the housing which can be provided. It is not an infrequent occurrence for an effort to be made to keep a farm flock which is very much too large for the available housing space. In such cases the hens, being crowded, do not give good results, and frequently a better profit would be realized by keeping

#### A Less Profitable Hen.

She produced only 80 eggs in the same period as the hen on the opposite page.





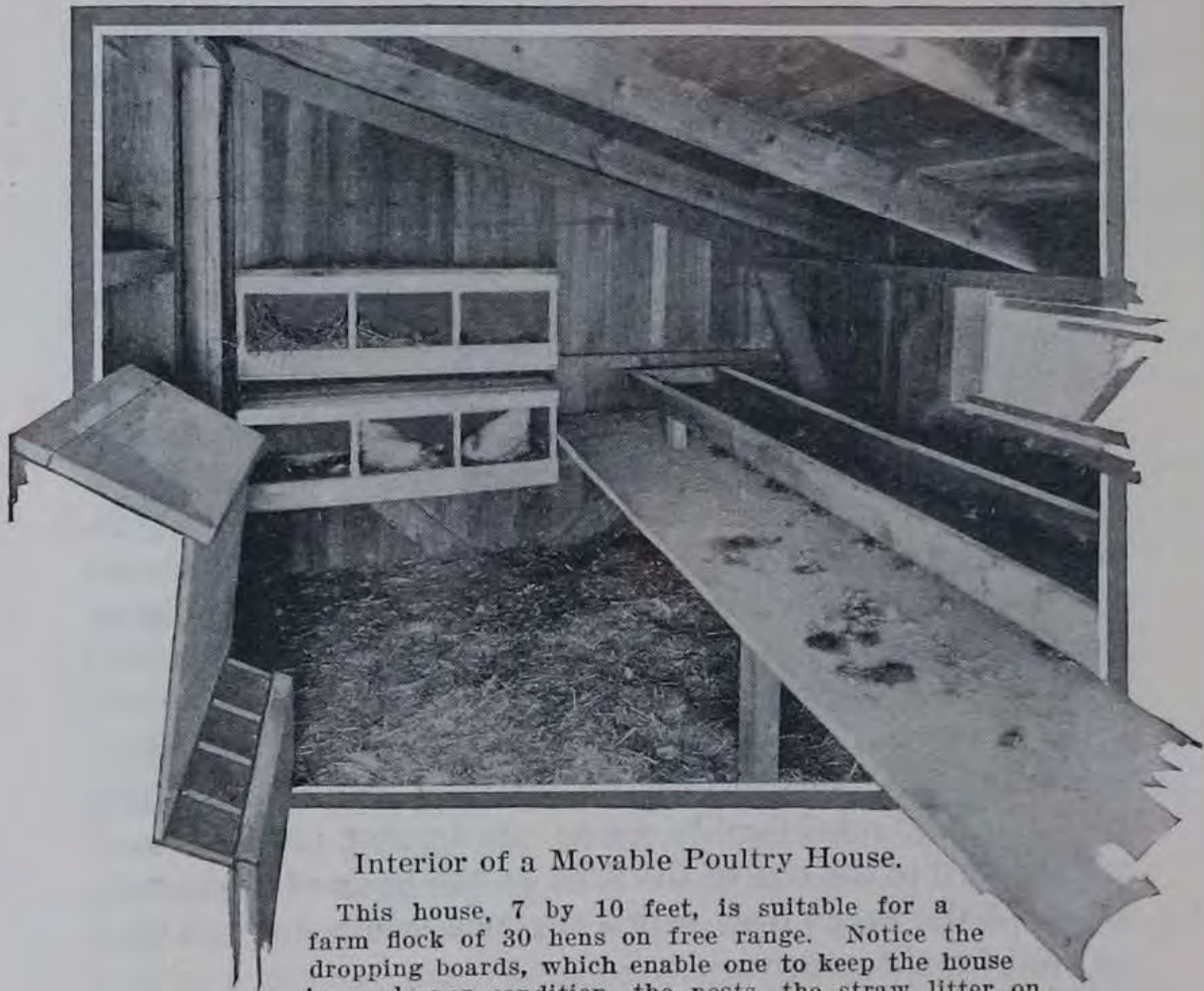

Interior of a Movable Poultry House.

This house, 7 by 10 feet, is suitable for a farm flock of 30 hens on free range. Notice the dropping boards, which enable one to keep the house in a cleaner condition, the nests, the straw litter on the floor to promote exercise, the dry-mash hopper, and the ventilator in the rear wall for use in hot weather.

a smaller flock which can be comfortably housed rather than the larger flock which results in crowding.

#### ESSENTIALS OF GOOD HOUSING.

Suitable housing does not mean expensive housing. Frequently old sheds or other outbuildings can be easily and cheaply transformed into suitable poultry houses. While there may be a great range in the kind of house used, and while the owner may consult his own preferences to a considerable extent, certain fundamentals of good housing must be observed. Such fundamentals consist of a house which is free from drafts, which provides plenty of ventilation either by an open front or by the use of windows, which is dry, and which provides space enough for the hens to keep them comfortable and contented. Where it is necessary to confine the flock to the yard, not less than 4 square feet of floor space should be allowed for each hen. With hens upon free range, as they should be whenever possible, a minimum floor space of 3 square feet per hen should be allowed.

GOOD FEEDING AT MODERATE COST.

Feeding, of course, is important. If the hens do not get sufficient or proper feed they can not be expected to give satisfactory and profitable results. A complicated ration is not necessary. The aim in feeding the hens should be to use, so far as possible, the grains which are grown on the farm or which are available in the immediate neighborhood. One of the most successful methods of feeding is to give a light feed of grain or a mixture of grains in the morning and a feed of the same material at night, the night feed consisting of about as much as the hens will clean up. In

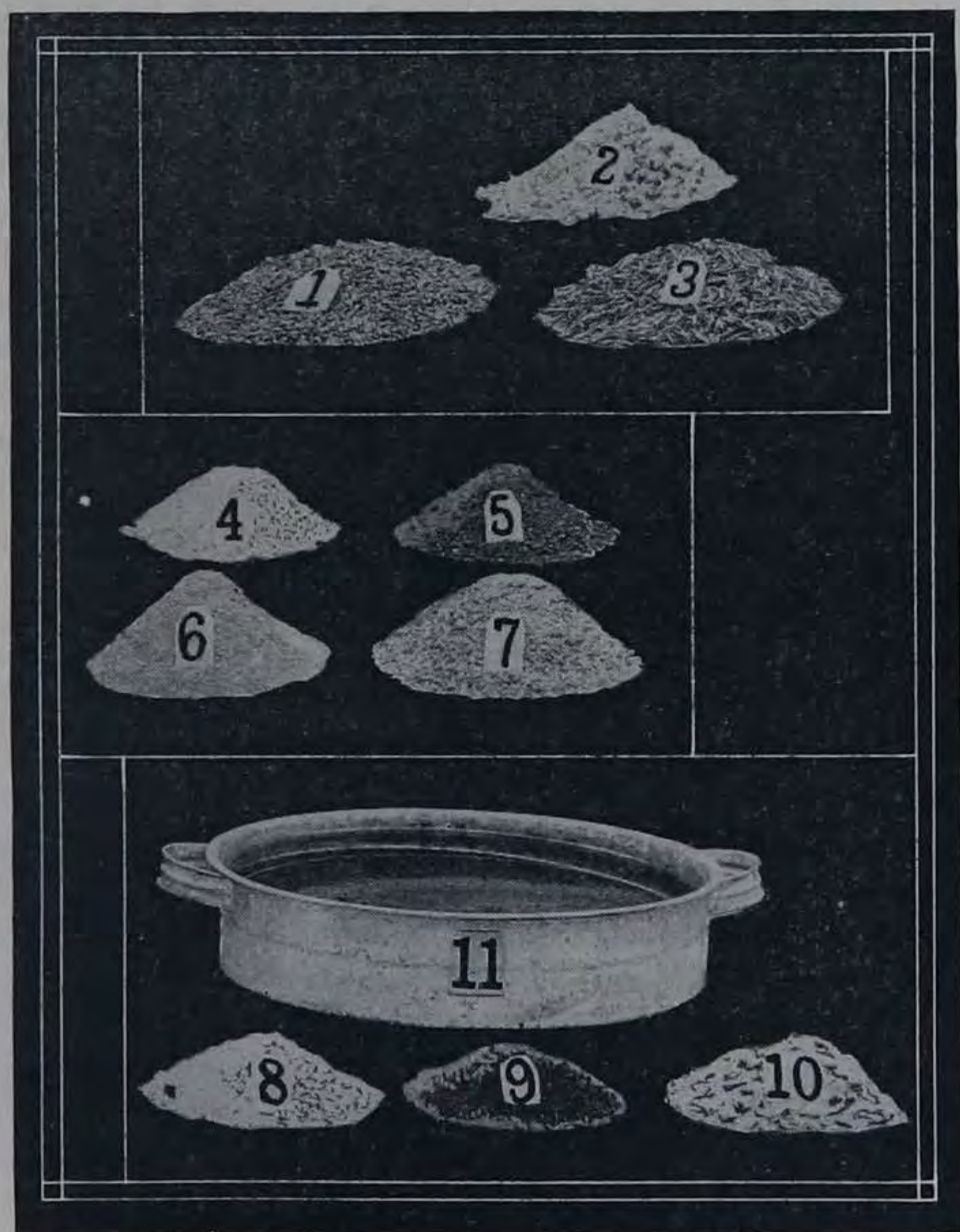

Suitable Feeds for Poultry.

1, Wheat; 2, cracked corn; 3, oats; 4, corn meal; 5, meat scrap; 6, middlings; 7, bran; 8, grit; 9, charcoal; 10, oyster shell; 11, water.

addition a dry mash should be provided where the hens can have access to it continuously. When considerable quantities of waste food are available for the hens to pick up from the fields, the amount of grain fed may be cut down. Oftentimes judgment in this respect is faulty, and but for the dry mash there would be danger that the hens would not receive enough feed. With the dry mash at their disposal they are able to make up any deficiency of feed due to faulty judgment as to the quantity they get in the fields.

One of the most common mistakes made in feeding farm poultry is failure to provide animal food in some form. Of course during the spring and summer, when quantities of insects are available, they may supply the hens' wants in this regard, but during those parts of the year when insects are not available, or are scarce, it becomes necessary to provide animal food. Milk, usually fed either as skimmed milk or buttermilk, provides an excellent source of animal food, but when milk is not available the hens should have beef scrap or meat scrap. While this product is high in price, it is economical, and should be included in the hens' ration because of the increased production which will result.

During the winter it is necessary to provide some form of green or succulent feed, such as mangels, cabbage, clover, alfalfa, or sprouted oats.

#### TIMELINESS OF HATCHING.

With the average small farm flock where hens of a general-purpose breed are kept, it is most satisfactory to let the hens do the hatching. When the hens are of a nonbroody breed it is of course necessary to use incubators or else to purchase baby chicks. Whatever the method of hatching, it is most important that this be done at the right time of year. The proper time of hatching varies with different localities, being earlier in the South and latest in the extreme North. The aim should be to hatch the chicks at such a time as will allow the pullets to reach their full development and begin laying in October or November, as these earlier maturing pullets must be depended upon very largely for the fall and winter egg production. Late-hatched chicks do not mature in time to produce fall and winter eggs, nor do they live or grow so well during the hot weather, which comes when they are still young.

## METHODS OF BROODING.

In raising the chicks, if hens are used for hatching, they of course can be used also for brooding. It is best to confine the hen to a coop for at least two weeks, allowing the chicks to come and go as they please. If hens are not available for brooding it becomes necessary to resort to a heated brooder. Perhaps the most successful method of brooding now in common use is the coal-stove hover, which is placed in a colony house and which allows brooding of from 300 to 400 chicks in one lot.

The important thing in raising chickens is to see that they are liberally fed and have proper conditions for development so that they will make a continuous growth. Anything which checks the growth of chicks has a lasting effect upon their development in later life. As the chicks grow older and larger and do not need heat it is very necessary that they have plenty of room in their growing quarters. Nothing will do so much harm and cause so much loss and trouble in growing stock as to keep them in crowded quarters. Be sure that the young stock have roost room enough so that they can all get on the roosts without undue crowding.

## PRINCIPAL POINTS IN MANAGEMENT.

In any lot of chicks there will be found certain stunted or unthrifty individuals. Such birds will never pay for the feed and care used in trying to rear them. It is not only good sense but good business judgment to cull these un-



A Happy Family.

But do not let the hen run with the chicks until they are at least two weeks old. Otherwise chicks that could have been saved will be lost.

thrifty chicks just as soon as they are discovered. There will also be found certain cockerels which exceed their fellows in the rapidity of growth and maturity. It is well to mark and save such cockerels which reach a good size to use as breeders. In the general care both of the laying stock and the growing stock it is necessary to use good common sense just as in handling any other class of live stock. Regular attention must be given and care must be taken to see that their quarters are kept clean and sanitary. Carelessness and thoughtlessness are probably responsible for more poor results than is lack of knowledge as to what the flock really needs. If a farm flock is to be kept the aim should be, of course, to make it profitable. It is, therefore, poor business to neglect or overlook the usual everyday care which must be given the flock in order to get these profitable results.

Lice and mites are common and are not conducive either to good results with the flock or to the comfort of the fowls. It is absolutely unnecessary for poultry to be seriously troubled by either lice or mites. Regular attention and proper treatment of the quarters will rid the flock of mites, and if body lice are found the birds should be treated for these also. Usually if a place is provided where the hens can dust themselves they will keep the lice in check.

#### MARKETING TO OBTAIN FULL VALUE.

The marketing of the product, particularly eggs, has an important bearing on the profits of the flock. Under most conditions it is impossible for the farmer to seek a special market for his eggs, but he should be very careful to see that the eggs are gathered regularly and frequently and promptly taken to market. Failure to do this is responsible for the spoiling of a great many eggs. When the methods of buying are such that payment is made for good eggs only, a plan which is becoming more widespread and bids fair to be compulsory in most States, the farmer will suffer a decided money loss if he does not make it his business to see that all the eggs delivered are fresh and marketable at full value. One of the greatest causes of spoiled eggs during the hot summer season is the development of chick embryos in fertile eggs. This loss is preventable simply by produc-

ing infertile eggs. All that is needed to accomplish this is to separate the male birds from the females as soon as the breeding season is over. All the eggs sold will then be infertile and incapable of embryo development.

#### THE FARM FLOCK MADE PROFITABLE.

The farm poultry flock should be one of the most profitable branches of the farm business. To bring this condition about it is necessary to keep good stock and to have the flock of a suitable size, properly housed, fed, and cared for. This is not a complicated matter and the farmer should not think that it requires such specialized knowledge and skill as to discourage him at the start, make him throw up his hands with the cry, "What's the use?" and let the hens shift for themselves. The farm flock needs the application of good common sense in the form of proper care regularly given, to which the hens will respond just as quickly as the hogs, cattle, or horses.

# WHY PRODUCE INSPECTION PAYS



By H. E. KRAMER, *Specialist in Charge, Food Products Inspection Service*, and G. B. FISKE, *Investigator in Marketing Fruits and Vegetables, Bureau of Markets*.

WHAT about that car of farm produce? It is a long haul to New York or Chicago from Melon Valley or Potatoville. Many are the links in the moving chain of transportation between the remote shipping points and the big terminal markets.

When a link breaks, slips, or forms a kink the people at each end know something is wrong, but it is not so easy to be sure of the kind, extent, or location of the trouble.

## FROM FARM TO MARKET.

The receiver telegraphs that the carload is in bad condition. There is poor grading, or careless packing, frost damage, overripeness, rot, breakage, mold, disease, or any one of half a dozen other kinds of injury. The shipper naturally is worried. There is a prejudice in favor of one's own produce and nobody likes to believe it is not as good as any in the market.

Has the shipper still to learn how to grade and pack properly? Did the produce really arrive in bad order, or did some unscrupulous dealer possibly seize upon a trifling excuse to reject a shipment arriving on a falling market, or did he seek a pretext to depress its value or to gloss over

a sale made at what seemed unduly low prices? If really damaged, to what amount? Was the whole load affected? What was the actual condition on arrival? Was the loss due to bad handling and packing or to delay and neglect by the transportation company or by the receiver? Was the cause a disease which may develop also in the rest of the crop?

#### INFORMATION NEEDED.

Some of these questions interest the receiver and the railroads as well as the shipper or producer. No one cares to assume blame and incur loss for what happened to the produce while it was in the hands of others. How settle all these questions without undue expense or delay? Since the establishment of the Federal Inspection Service two years ago, the answer is comparatively simple. "Telegraph to the Federal inspector in the nearest large city, asking him to report on the shipment." He is a trained man with considerable experience in handling produce, a competent and certified judge of grades and condition.

#### THE USEFUL CERTIFICATE.

The inspector's verdict is commonly accepted by dealers and shippers and by courts, railroads, and express companies. With the shipment officially inspected, all parties concerned have learned all that it is practicable to know about its exact condition and grade, and many causes of troublesome disputes, costly law suits, and lasting dissatisfaction are removed. The inspection certificate is a prime lubricator of the long chain belt that runs from Truckville to the big city. It removes fully half of the sources of worry and uncertainty, and narrows the market question down chiefly to a matter of salesmanship. When the exact nature of the goods is known, the buyer and seller can get together in business, regardless of distance.

The shipper wants the certificate as proof that the stock was graded as he marked and billed it, and as evidence that it arrived in good condition, or at least to show the exact extent of depreciation. The receiver wants the certificate as a fair explanation of his failure to accept the goods at the stated price, or to sell them as first-class produce. The man



in the country and the man in the city each know that the other has a copy of the certificate, and there is little room left for dispute regarding the basis of settlement. Railroads are using the inspection service more and more in order to know where they stand in the event of claims for damages. The inspector's report may even help to locate the cause of the trouble—whether it started during the harvest or during the railway journey or in the receiving yard. Shipments tend to become standardized, and all parties are better assured of obtaining full value for their money under the inspection system.

The result is the saving of large sums in the aggregate. According to a statement from the Quartermaster's Office, the Government was saved thousands of dollars through inspection, by the Department of Agriculture, of produce shipped to Army camps during the war. A few contractors had been trying to "put over" short-weight packages and low-grade lots of various kinds, and Army officers sometimes lacked the necessary experience to detect these practices, but competent inspection promptly put a stop to the practice.

In the words of a prominent official of the Interstate Commerce Commission, the inspection certificate presents "a visual picture of the exact condition of the car at the time of inspection. The service is of untold value to the farmers and produce men of the country. I have yet to hear of a single case where any of the inspectors had been accused of partiality or unfairness."

#### TRADE INSURANCE.

All this is a kind of trade insurance. The buyer knows just what he is buying at the receiving point. The shipper also knows, and each is aware that the other knows, too, for a copy of the inspection certificate is sent to each. The advantage of this definite, up-to-date knowledge of the shipment is so evident that many shippers and dealers ask inspection as a matter of precaution. The small fee charged is inconsiderable if it tends to prevent any misunderstanding or suspicion of unfairness on either side.

## LEARNING FROM INSPECTION.

The direct aid in arriving at the value of the produce is by no means the only gain through inspection service. Inspection is like a doctor's verdict. It locates and names the trouble but does not directly remove the cause. Nevertheless it includes hints which to the wise are useful.

A standard is supplied for judging one's own methods, as well as the system used at the other end of the line. Whose



Proper Loading.

Careful packing, loading, bracing, and ventilating show results in safe carriage.

fault is it that the potatoes were frozen, and how can further trouble of that very common kind be prevented? Was there rot in the car, and was it of a species that starts in the field, or did it follow bruising or overheating or low temperature? Did the car of sacked potatoes rightly sell lower than the bulk stock supposed to be of the same grade, and whose fault was that peculiar state of affairs? Did the car of

wilted lettuce spoil because it was too long on the way, or was the receiver slow in getting out the shipment after arrival, or was the trouble partly due to poor packing and insufficient icing, or was the lettuce diseased in the first place and unfit for long shipment? Was the car of cabbage really short weight, and was it so at the start or because of theft en route, or was it merely shrinkage, and if so, by whose fault? How much of the trouble could have been prevented by the shipper if more care in spraying, harvesting, grading, and packing had been exercised; and how much by the railroad through more equipment, better cars, or more care by employees? Finally, did the receiver properly look after the goods and give the shipper a square deal, or might not some other dealer have done better?

Not all these questions may be fully answered from a single inspection. In some cases there must still be uncertainty because of the lack of official examination at the shipping point. So far, neither the authority nor the money has been provided for a service of that kind, although a widespread demand for it prevails. Shipping point and market inspections would check each other, and the former would frequently obviate the need for the latter.

#### THE LINES OF INSPECTION.

Requests for inspections are in proportion to volume of shipments, being much more numerous during the active harvest season, and being divided among the commodities somewhat according to the proportion of each to the total shipments of produce. Thus potatoes, apples, onions, and cabbage among countrywide staple lines lead in volume of shipments moved, and also in number of inspections made. Potato shipments for the 1918-19 season included 4,500 inspections to 176,479 cars shipped; apple shipments, 25,581 cars with 1,573 inspections; onions, 22,551 cars and 1,040 inspections; cabbage shipments, 29,360 cars with 894 inspections. Similar relative figures are shown for the standard lines moving in smaller volume, but for highly perishable fruits and vegetables that move in heavy volume for a short season only, inspections are not so heavy in proportion to shipments. For a few weeks at the height of the season, watermelons lead the list; the total number of cars for last



**Damage in Transit.**

Southern eggplant damaged by heavy loading and insufficient refrigeration in transit. The grapes also were damaged in transit.

season was 20,394, but inspections were only 388. Peaches followed with 20,409 cars, while inspections were 449. Strawberries, another heavy, short-season crop, resulted in inspections for only 41 cars.

**BY SKILL AND MAIN STRENGTH.**

Popular notion might picture the inspector standing by the car door, a well-dressed, dignified official, notebook in



Damaged Potatoes.

These potato barrels should have been piled on ends to prevent crushing. The picture to the left shows bacterial soft rot in southern potatoes.

hand, while a gang of laborers overhauls the carloads and pulls out samples from bags, boxes, or barrels. The camera would show something different. A typical inspector is an active, energetic young man whose hands show marks of hard work. He is a trained judge of quality and condition, but in practice he is a man of labor, for he works long, and very real work it is, to obtain all the facts for the much desired "visual picture of the exact condition."

Said an inspector in one of the great market centers: "At first the produce men were inclined to rate us as just one more set of officials, but when they saw one of us put on overalls and jumper, crawl into a car of potatoes and haul

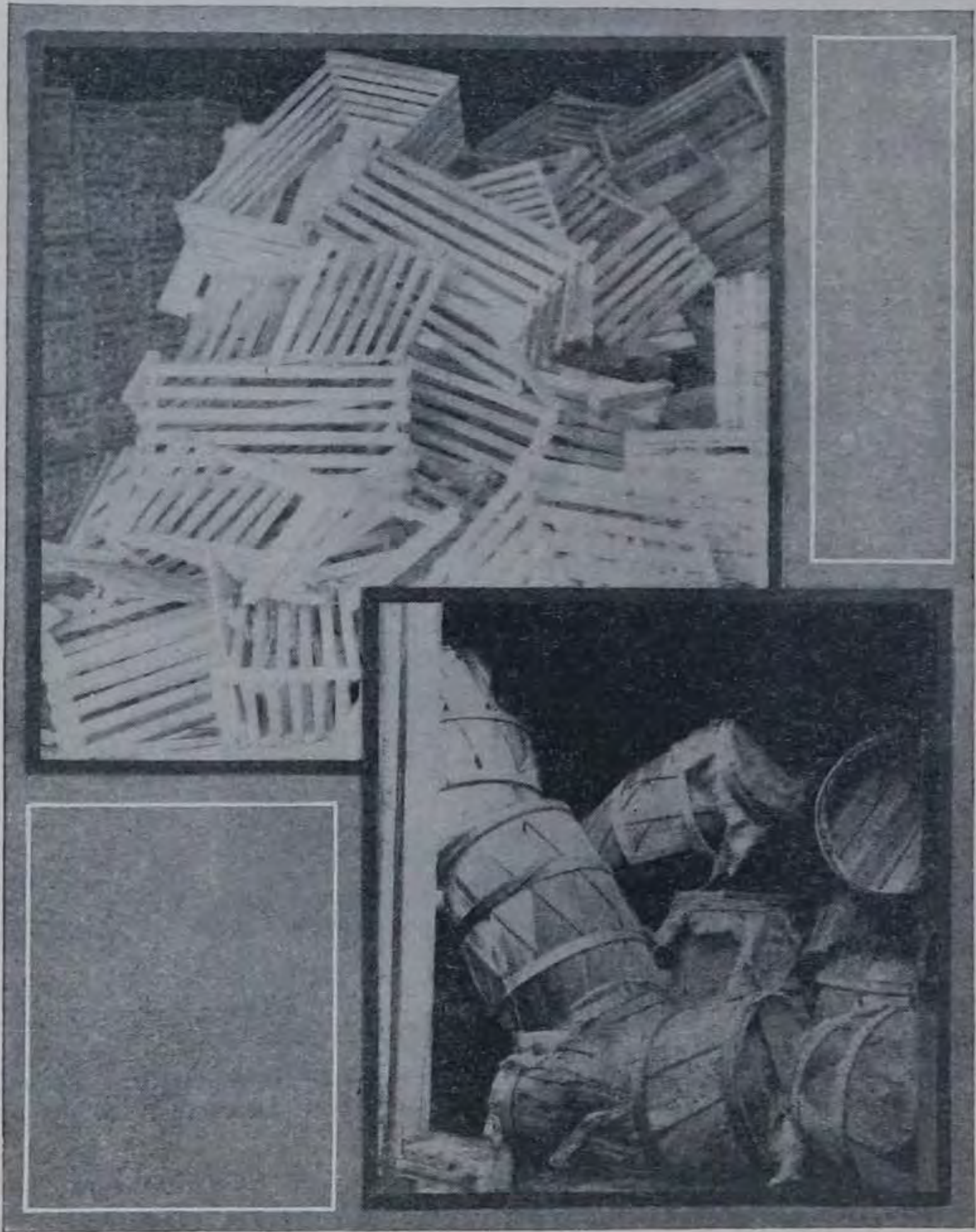

Results of Improper Loading.

Broken onion crates from Texas and southern potatoes in barrels both damaged because of improper loading.

them over, lifting heavy, dusty bags to get at the bottom layers, and coming out tired as a ditch digger and dirty as a tramp, then they took us seriously. At the height of the season in warm weather, with from 15 to 20 cars of potatoes

to inspect in one day, it is hard, disagreeable work. We had to do the job thoroughly because we felt that one mistake would cause the service more harm than work not done owing to lack of time. Hence, during the season many disputes had to be settled as well as possible without our help."

#### GETTING AFTER THE CAR LOTS.

The receipt of a request is followed by inspection of the goods as soon as time permits. The inspector, if supplied with a fair description, is usually able to locate the car promptly through inquiry from the railroad officials at the freight yard. Having found the car he breaks the seal on the door, climbs inside, and digs out and inspects packages at top, bottom, center, and ends, if necessary. The amount of sampling varies with the conditions. For instance, the work is severe with a car of potatoes suspected of several defects, such as rot and poor grading, and which is put up by different shippers using the one car. Plainly the inspector must examine many samples to get a complete view of the condition of each lot in the car. Bag, barrel, or box samples are opened, contents taken out and weighed or counted, and the condition noted. The culls, rots, or low-grade specimens are weighed, the per cent of each calculated, and the results transferred to the inspector's notebook. All notes must be set down before leaving the car, as often there are several cars for one receiver but from different shippers, and, without notes completed on the spot, confusion might occur in making out the certificates.

After the inspection the actual filling out of the certificate is still to be done, with a copy for the shipper, no matter who made the application for the inspection. The observations recorded in the book are boiled down to a few statements, which, nevertheless, tell the story so that the main points may be seen at a glance, for the inspector is a practical man and as a rule certifies only to conditions that are of prime importance to those interested in the carload.

Many of the inspections are wanted only to establish certain facts, such as suspected short weight, or under grading, or rot. In that event the certificate brings out chiefly the presence or absence of these defects and the amount and kind of injury or deficiency.

## A SAMPLE INSPECTION.

A typical inspection certificate taken at random includes the following main points. It describes a car of potatoes from New Brunswick examined at Cleveland, Ohio, last October, upon request of the firm to which the car had been sent. The contents are described as "Sacked round white potatoes loaded 5 layers high, 5 rows wide, both ends of the car; nothing loaded in doorway; no marks on sacks. Condition of load and container intact. Coarse sacks of good quality noted. Temperature of products not taken. Size mostly medium. Meets size requirements of U. S. Grade No. 1. Stock clean, bright, well matured. Decay very irregular, approximately 5 to 6 per cent of stock by weight; one end of car decayed; other end of car, decay very irregular, ranging from none in many sacks to as high as 25 to 35 per cent in a few. Most sacks in which decay was noted show 12 to 15 per cent of contents decayed (late blight tuber rot). Approximately 3 to 4 per cent of the stock by weight seriously blemished, consisting of sunburn and deep flesh shattered bruises. The allowance for blemishes in U. S. Grade No. 1 is 6 per cent. The load as a whole does not meet requirements of U. S. Grade No. 1 on account of some sacks containing late blight tuber rot as noted. Stock in many sacks not showing decay is clean and presents good general appearance."

## INSPECTION AS A PREVENTIVE.

The probability of an inspection reduces the danger of sharp practice at either end of the line. Like the physician, the inspector is constantly striving toward a reduction of the need of his services. With the comparatively few tricky and incompetent people weeded out, or brought to see the folly of their ways, a greater degree of mutual confidence would develop among produce men. Shipments would become more nearly standardized and fewer inspections would be needed. Even the prospect of inspection often has a wholesome effect on business practice. For instance, a car was rejected in a market at which inspection service had not been established. The shippers telephoned to Washington and arranged for an inspection of the produce. Meanwhile the receiver had notified the shippers that the price



must be reduced 50 cents per package, but when he learned that an official inspection was to be made, he telegraphed the shippers to withdraw the request for inspection and he would accept the car at the original price, as he had found it not to be so bad as he had thought.

It must not be supposed that the receiver is always to blame for rejections or that the shipper does not often need the restraining check of a possible inspection which will sustain the receiver in his view that the stock is not up to requirements. Here are two or three samples from inspection certificates which suggest decided room for improvement at the shipping end.

(1) Fifteen barrels Ben Davis and Gano apples: "Three layers of grade 1 apples on top of barrels and two layers of grade 1 apples on bottom of barrels. Balance (90 per cent by weight) made up of cull apples averaging one-half to  $1\frac{1}{2}$  inches in diameter. Many culls stunted and misshapen."

(2) Car cabbage: "'A' end of car (opposite brake end) shows 75 per cent overripe and defective cabbage covered over with nice medium-sized green cabbage on surface, and under surface to depth of  $1\frac{1}{2}$  feet. 'B' end shows 25 per cent overripe and defective cabbage covered over with nice medium-sized green cabbage to depth  $3\frac{1}{2}$  feet."

(3) Car watermelons, loaded four layers deep: "Top layer averaged 21 pounds each. Second layer averaged 17 pounds each. Third layer averaged 15 pounds each. Fourth layer averaged 14 pounds each. Average weight for car, 17 pounds."

Much damage noted at the receiving end is due to unsuitable methods of packing and loading. The illustrations show a number of instances where loads arrived in extremely bad order because proper precaution was not taken at the shipping end. The report of such happenings, as recorded on the inspection certificate, is often of immediate value to the shipper. Said an inspector in one of the prominent markets: "Last summer I had occasion to write to one shipper selling potatoes, calling his attention to the poor condition in which they reached the market and the poor loading. He investigated and found that shipments were going out under much different conditions than he thought prevailed."

The inspection service also brings about more careful trading between shippers and dealers; returns and conditions of sale are stated with greater clearness and precision, and more agreements are being put down in writing. Thus the buyer and the seller are more nearly in agreement on their contracts, and chances of misunderstanding or misinterpretation are reduced.

Naturally, the inspector's work meets occasional criticism, sometimes with a spice of humor, as witness the following from a Texas shipper:

Your inspection certificate received. It sounds like a monumental joke. "Loaded to less than a foot of the roof." How is one to get the minimum unless he loads? "Thirty to forty per cent of stock shows one or more outer leaves in a slimy condition—due chiefly to water soft rot." Tell me, please, how do you distinguish between rot caused from heat and rot caused from water? "Due to decay." Would a car of lettuce decay in five days if it were properly iced during the five days? Would filling the bunkers with ice restore the condition of the lettuce? Could you tell by looking at a car of lettuce if the decay was caused from a failure to ice while in transit? Or from water rot? Or dry rot? Or cold rot? Or tommyrot?

As a counterweight there are scores of highly enthusiastic letters commending the work, some mentioning specific savings of hundreds or thousands of dollars because facts were established regarding the condition and quality of the shipment.

On the whole, the service is welcomed even more gladly by receivers than by shippers. Nearly two-thirds of the inspections were made on behalf of receivers, the others were made at the request of shippers and the railroads or transportation companies.

#### HOW TO GET THE SERVICE.

Anyone concerned in the shipment may ask for inspection. If there is trouble over the produce, or if there is merely a wish to avoid possible difficulty later on, the applicant writes or telegraphs to the United States Food Products Inspection Service, Bureau of Markets, in the city where the car is to be received. A small fee is charged for each inspection. This fee is \$2.50 for any quantity from half a carload up to a full carload, and \$1.50 for any quantity less than half an ordinary carload. For inspections

made in the smaller markets where no inspector is permanently located the applicant is charged with the actual expenses incurred by the inspector in making the trip in addition to the regular inspection fee. It is by no means a service wholly for large shippers. Small lots by freight or express may be inspected on the same general conditions as full carloads. However, the law provides that inspections may be made only on such shipments as have moved in interstate commerce.

The idea of official inspection is to provide a reliable, disinterested report as a basis for settling disputes regarding quantity, quality, grade, or condition. No matter who asks for it or who pays the bill, whether producer, dealer, or railroad, the other party may have a copy of the report. If the shipper and dealer can not agree, or if there is a damage claim against a transportation company which results in a suit, the certificate is *prima facie* evidence in the Federal Courts on the points which it covers.

The request for inspection should tell where the car may be found and the number, and should give also the main facts about the contents, calling attention to any special point as to grade, quality, or condition. The inspector will do the rest.

#### STORY OF TWO YEARS' WORK.

Federal inspection began in November, 1917, and has continued to grow in response to increasing demand. Inspection stations have been established in 30 leading cities, each with a considerable neighboring territory in which inspections from the central office are made. Altogether the service is available in 164 cities, as shown on the map herewith. A majority of the inspectors are in the great centers of population east of the Mississippi. Beginning with a few hundred inspections in November and December, 1917, a volume of between 2,000 and 3,000 a month was reached during the height of the shipping seasons of 1918 and 1919. Total inspections during these two years approached 30,000.

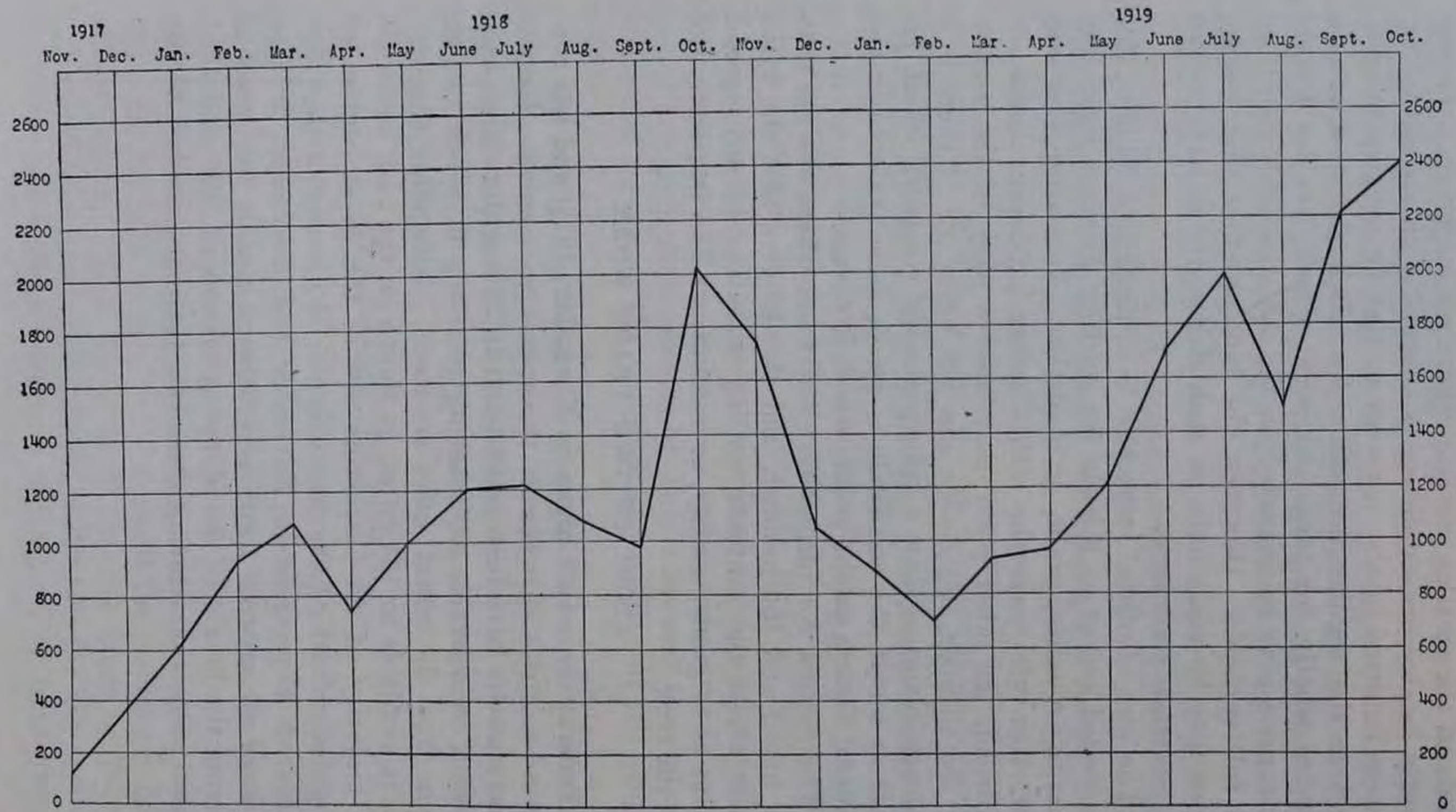

Increase in Numbers of Inspections during the Harvest Seasons and from Year to Year.

DESIGNATED INSPECTION MARKETS.

Inspection service is now available in the markets named on the next page. Inspection offices are established only in cities printed in heavy type; if an inspection is desired in one of the smaller cities in the list, communicate with the inspection office under which that par-

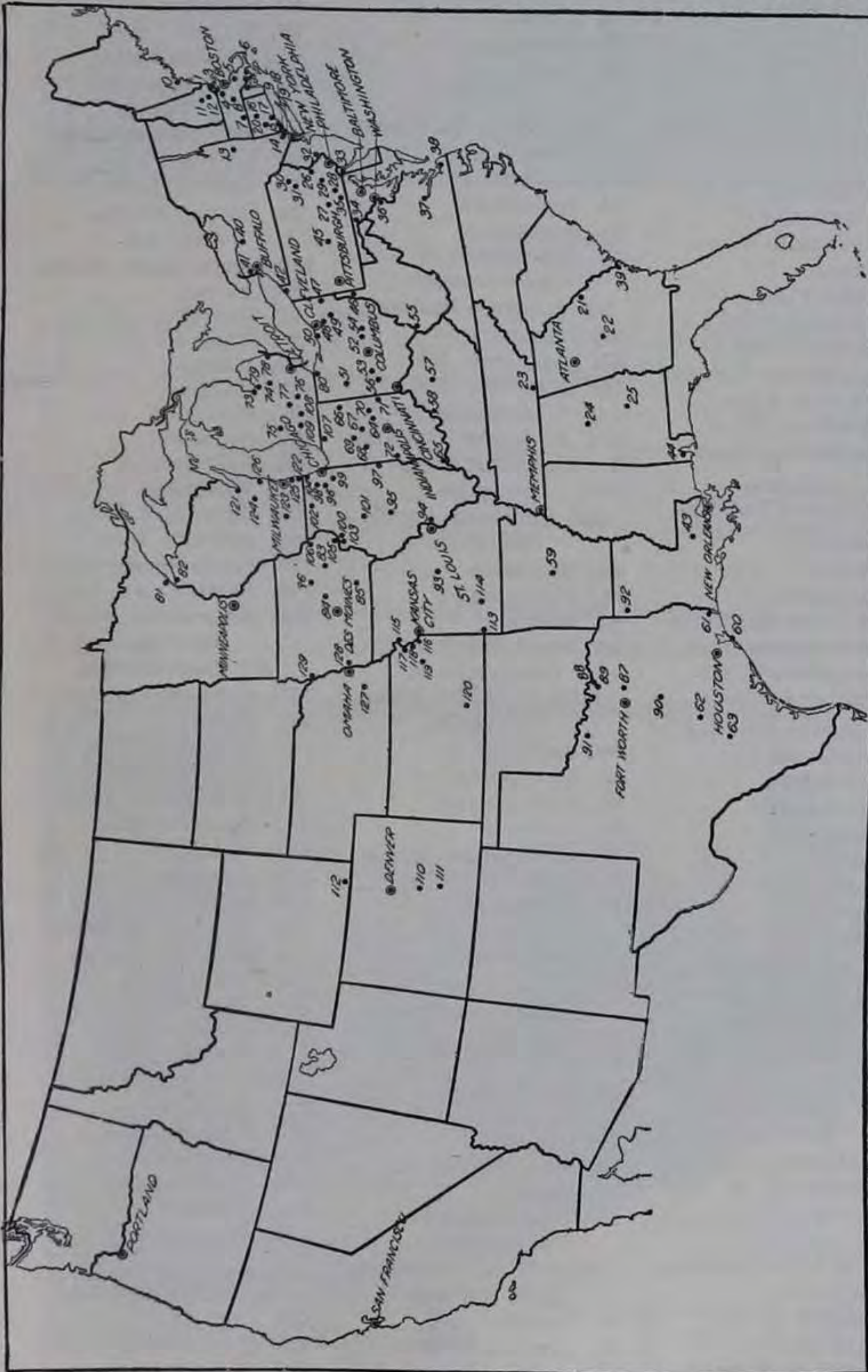

Location of 30 Main Inspection Points and Total of 160 Points where Inspections may be obtained. (See page 334, for inspection points listed by States.)

ticular market is listed. The small towns immediately adjacent to the larger cities like New York or Boston are considered as included in those markets. Applications for inspections should be addressed by mail, telegraph, or telephone to the Food Products Inspector at the address given.

- BOSTON,  
Appraisers Store Building.  
1. Haverhill.  
2. Fall River.  
3. Lawrence.  
4. Lowell.  
5. Brockton.  
6. New Bedford.  
7. Springfield.  
8. Worcester.  
9. Providence, R. I.  
10. Portland, Me.  
11. Concord, N. H.  
12. Manchester, N. H.  
NEW YORK,  
204 Franklin Street.  
13. Albany.  
14. White Plains.  
15. Bridgeport, Conn.  
16. Hartford, Conn.  
17. New Haven, Conn.  
18. Norwalk, Conn.  
19. Stamford, Conn.  
20. Waterbury, Conn.  
ATLANTA,  
405 Connally Building.  
21. Augusta.  
22. Macon.  
39. Savannah.  
23. Chattanooga, Tenn.  
24. Birmingham, Ala.  
25. Montgomery, Ala.  
PHILADELPHIA,  
308 Bourse Building.  
26. Allentown.  
27. Harrisburg.  
28. Lancaster.  
29. Reading.  
30. Scranton.  
31. Wilkes-Barre.  
32. Trenton, N. J.  
33. Wilmington, Del.  
BALTIMORE,  
411 Customhouse.  
34. Hagerstown.  
35. York, Pa.  
WASHINGTON, D. C.,  
United States Bureau of  
Markets.  
36. Alexandria, Va.  
37. Richmond, Va.  
38. Norfolk, Va.  
BUFFALO,  
232 Post Office Building.  
40. Rochester.  
41. Niagara Falls.  
42. Erie, Pa.  
NEW ORLEANS,  
315 Pan American Building.  
43. Baton Rouge.  
44. Mobile, Ala.
- PITTSBURGH,  
303 Kellerman Building.  
45. Altoona.  
46. Wheeling, W. Va.  
47. Youngstown, Ohio.  
CLEVELAND,  
503 Erie Building.  
48. Akron.  
49. Canton.  
50. Lorain.  
COLUMBUS,  
303 Marlin Building.  
51. Lima.  
52. Newark.  
53. Springfield.  
54. Zanesville.  
55. Huntington, W. Va.  
CINCINNATI,  
209 Johnston Building.  
56. Dayton.  
57. Lexington, Ky.  
58. Louisville, Ky.  
MEMPHIS,  
404 Exchange Building.  
59. Little Rock, Ark.  
HOUSTON,  
925 Southern Pacific  
Building.  
60. Galveston.  
61. Beaumont.  
62. Austin.  
63. San Antonio.  
INDIANAPOLIS,  
1102-1103 City Trust  
Building.  
64. Anderson.  
65. Evansville.  
66. Fort Wayne.  
67. Kokomo.  
68. La Fayette.  
69. Logansport.  
70. Muncie.  
71. Richmond.  
72. Terre Haute.  
DETROIT,  
445 Howard Street.  
73. Bay City.  
74. Flint.  
75. Grand Rapids.  
76. Jackson.  
77. Lansing.  
78. Port Huron.  
79. Saginaw.  
80. Toledo, Ohio.  
MINNEAPOLIS,  
302-303 Market State  
Bank Building.  
81. Duluth.  
82. Superior, Wis.  
DES MOINES,  
215 United States Court-  
house.  
83. Cedar Rapids.  
84. Marshalltown.
- DES MOINES—continued.  
85. Ottumwa.  
86. Waterloo.  
FORT WORTH,  
505 Moore Building.  
87. Dallas.  
88. Dennison.  
89. Sherman.  
90. Waco.  
91. Wichita Falls.  
92. Shreveport, La.  
ST. LOUIS,  
413 Old Customhouse.  
93. Jefferson City.  
94. East St. Louis, Ill.  
95. Springfield, Ill.  
CHICAGO,  
139 North Clark Street.  
96. Aurora.  
97. Danville.  
98. Elgin.  
99. Joliet.  
100. Moline.  
101. Peoria.  
102. Rockford.  
103. Rock Island.  
104. Waukegan.  
105. Davenport, Iowa.  
106. Dubuque, Iowa.  
107. South Bend, Ind.  
108. Battle Creek, Mich.  
109. Kalamazoo, Mich.  
DENVER,  
308 Customhouse.  
110. Colorado Springs.  
111. Pueblo.  
112. Cheyenne, Wyo.  
KANSAS CITY,  
212-213 Railway Ex-  
change Building.  
113. Joplin.  
114. Springfield.  
115. St. Joseph.  
116. Kansas City, Kans.  
117. Atchison, Kans.  
118. Leavenworth, Kans.  
119. Topeka, Kans.  
120. Wichita, Kans.  
MILWAUKEE,  
314 Federal Building.  
121. Green Bay.  
122. Kenosha.  
123. Madison.  
124. Oshkosh.  
125. Racine.  
126. Sheboygan.  
OMAHA,  
436 Keeline Building.  
127. Lincoln.  
128. Council Bluffs, Iowa  
129. Sioux City, Iowa.  
PORTLAND, OREG.,  
410 Oregon Building.  
SAN FRANCISCO,  
510 Battery Street.

# HOME PRODUCTION OF LIME BY THE FARMER

By C. C. FLETCHER,  
*Bureau of Soils.*

THE value of lime in agriculture has long been recognized, but even now only a small proportion of the amount which could profitably be used is used by the American farmer. The building up of soil by proper crop rotations, which include legumes, is almost essential, and is becoming more general. As this practice is extended the use of lime will undoubtedly increase. Limestone soils are universally recognized as rich soils and especially suitable for stock farming, where proper mixed hay and pastures are vital.



Small Crusher Operated  
by Farm Tractor.

This outfit actually produced 300  
tons in 30 days.

By the use of ground limestone practically any farmer, usually at a moderate expense, can make his soil a limestone soil.

In most instances it is the best business policy to buy lime from large plants where it can be produced cheaply. Where a lime from this source can be readily obtained it is very doubtful whether it would pay the farmer to produce his own lime.

In certain cases, however, unless the farmer can produce it himself, it is either very difficult or expensive to secure



Limestone Pulverizer.

This machine, mounted on a homemade truck, is used for custom work. Two piles of pulverized rock are shown in the foreground. Note wheelbarrow below truck.

materials for liming. In many cases transportation is too costly to justify the use of lime purchased at centers of supply. In other cases the existence of local material and the advisability of using power or labor which would otherwise go to waste make it the best policy to produce lime on the farm.

Over considerable areas are found beds of marl of varying purity which may be used locally at a very low expense. Where this material is in such a condition as to need no grinding it may be applied to the soil and answer every



purpose that more costly artificially prepared forms of lime would serve. Much will depend on the grade of material, the marls varying from deposits little richer than a limy soil to a material practically as pure as high grade limestone. In some rural communities are sources of power, such as sawmills, which are only used for a portion of the year. In cases of this kind it may be possible to utilize this power for lime grinding, and thus lower the price of the product. In other cases, as at prisons, reformatories, institutions for the insane, etc., there is available a large amount of unpaid or cheap labor which may be used to produce lime for the institution farm or even for sale to neighboring farmers.



A Small Stationary Plant.

Shows a convenient method of storing and loading ground limestone.

Agricultural lime usually is considered to include both the carbonate of lime as found in ground limestone, marl beds, and shells, and the oxide of lime, which is the carbonate after it is burned and the carbon dioxide has been driven off by the action of heat. Dolomitic limestones, which contain both calcium and magnesium carbonate, may be used as a source of material for small plants in about the same manner as the calcium limestones. In most cases it will not pay to produce agricultural lime from a poor grade of limestone.

Given a source of limestone or shells, the farmer has a choice of either grinding the material finely and using it in the form of carbonate or burning it and using it in the form of oxide or



A Portable Machine in Operation with 12-25 Tractor as Power.

quiclime. In the early days of this country the burning process was the only one employed, but at present ground limestone is extremely popular. Good results agriculturally are obtained from lime in either of these forms.

Burning has certain advantages for small operations, chiefly because it takes no expensive equipment or power plant. Where only a small amount is needed all that is necessary is to use the so-called heap method. In this system a layer of two rows of dry cordwood mixed with lighter kindling is first laid down, next a layer of coal, next a layer of limestone, and above this several alternate layers of lime-

stone and coal. One part of coal should burn several parts of limestone. The outside of this heap is covered with soil and the kindling ignited. The burning of the wood and coal turns the whole amount of broken limestone into burned lime, the carbon dioxide escaping as a gas through an opening left in the top of the heap for this purpose. The process is not completely satisfactory unless the gas is allowed to escape.

This method produces a lime which is mixed with ashes, but as the coal ashes are harmless and the wood ashes beneficial to the soil no ill effects result from this mixture. Oyster or clam shells may be burned in a similar manner or may be burned in a special rack made of cordwood. In all cases the heat must be controlled and spaces must be left between the stone or shells for the flames to penetrate.

Where larger quantities of lime are to be made it may be advisable in some cases to construct a small cylindrical kiln, which may be lined with fire brick or sandstone. This is rarely advisable for the farmer at present, however, as under these conditions it would probably pay him better to purchase a grinding outfit.

The use of small crushers and pulverizers to produce ground limestone has proved satisfactory in many localities. They are naturally not as economical as a large plant but may save high freight rates to inaccessible localities. They are often employed also at off seasons of the year where labor would otherwise not be used to the best advantage. The most convenient outfit is a combination of crusher and pulverizer, but good results are secured from small pulverizers, although in this case a good deal more hand sledging has to be done. Portable outfits may be moved from place to place and thus utilize outcrops and save hauling. Where associations of farmers are buying machinery a stationary plant may be installed which should produce limestone at a low cost per ton. As each case is a business proposition which will have to be considered by itself, it is difficult to advise as to which type of outfit is the best purchase. Small grinding plants may be bought at present for about \$500 and larger ones in proportion. They may be run satisfactorily by tractors or other engines of from 10 to 20 horsepower, with an output from 1 ton per hour

up, depending on the type of rock and the horsepower employed. The cost of production will naturally vary, but may run from \$1.50 to \$3.50 per ton. Much depends on the character of the rock, the business ability of the men running the plant, and the cost of the power.

As the advisability of the production by the farmer depends on the saving effected, it is difficult to prophesy whether this practice will increase. The question is largely an economic one, although the possession of an independent supply of a basic material appeals to many men. At pres-

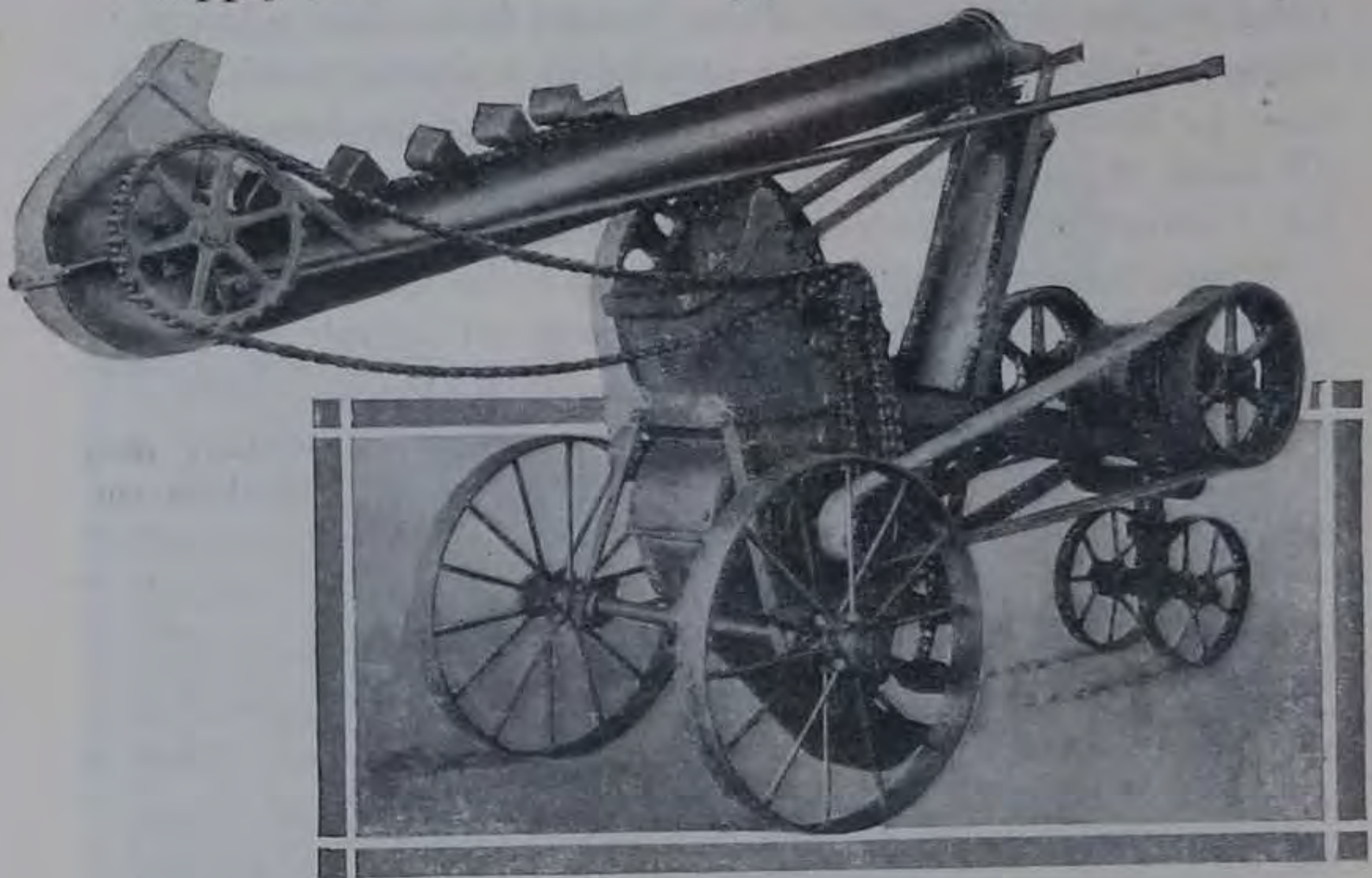

A Type of Commercial Pulverizer Showing Elevator Folded Back Ready to Move.

ent lime is a cheap product compared with its great value, and its cheapness naturally limits the extension of its production in small units. If it becomes high in price farmers over a large area of the country are in a position to prepare their own product.

While opinions differ widely on various points connected with the production of lime, there is a very general agreement as to the wisdom of its wider use. In this connection the reader will find interesting the resolutions adopted at a recent conference of workers in southern experiment stations. Though based on conditions in the Southeastern

States, the conclusions are probably applicable to much of the country.

(1) The agreement is unanimous that the soils of the Southeastern States are seriously deficient in lime, so that liming is essential to their most profitable development and permanent improvement.

(2) Suitable agricultural lime materials are high calcium, magnesian, and dolomitic limestone; also high-grade oyster shells and marl, together with the burnt products (or the chemical equivalents of such) of any of these in the amounts hereafter recommended by this conference.

(3) The finer the limestone is ground, the greater is its immediate availability. Limestone ground to pass through a 10-mesh screen, all finer particles included, is recommended for the common application of 2 tons per acre. Either very finely pulverized limestone or burnt lime is recommended, where an application of only a few hundred pounds per acre is to be made.

(4) For general use we recommend an application of 1 to 2 tons of ground limestone per acre, or one-half that amount of burnt lime, once in a rotation of not more than five years. For alfalfa and permanent pastures, an initial application of double these amounts should be made.

(5) Lime may safely be used at any point in the ordinary farm rotation without serious loss of the material. If applied in connection with tilled crops, its mixture with the soil will be insured. The effects of lime are likely to be in proportion to the thoroughness with which it is mixed with the soil in which the crop roots develop.

(6) Liming is most profitable in those rotations in which legumes are prominent; but over large areas in these States, especially on the heavier types of soil, liming is profitable for corn, small grains, and grasses.

(7) With soils poor in potash and phosphate, liming gives best results only when supplemented by materials carrying these constituents.

Faint, illegible text, possibly bleed-through from the reverse side of the page. The text is arranged in several paragraphs and is too light to transcribe accurately.

# WHAT THE FARMER SHOULD EXPECT FROM THE SEEDSMAN



By EDGAR BROWN,  
*Botanist in Charge, Seed-Testing Laboratories.*

THE public is coming to look more and more upon each line of business not alone from the standpoint of business profits, but from its relation to the general welfare. There is no business the conduct of which is of greater importance to productive agriculture than that of the seed trade. Every pound of seed containing dead seeds, weed seeds, trash, and adulterants that is sold to the farmer affects agricultural production in proportion to its quality. The seedsman holds a more directly responsible relation to agriculture than any other merchant, because the farmer is fundamentally dependent on the seed dealer for his crop seed. Any condition existing in the seed trade which allows poor seed to go into the ground is a detriment to productive agriculture and to the individual farmer. The seed business can no longer be looked upon only from the standpoint of its own gains, but must also be considered from the standpoint of its relation to agriculture.

When the farmer buys seed, he is entitled to all the information the seedsman has in regard to it. It is necessary for the farmer to know its origin; how much of it is of the kind it is represented to be; the proportion of it which may be expected to grow under normal conditions; and the proportion of weed seeds present, noxious or otherwise.

At present, nearly all of the larger seedsmen handling grass and field seeds have found it worth their while to have one or more persons connected with their firm who are familiar with seed testing and who can give them accurate information as to the quality of all the lots of seed they are buying

and selling. The enactment of State laws regulating the sale of agricultural seeds has made this necessary, and the seed business can not now be successfully carried on without it. Seed testing has no doubt rendered the business of seedsmen safer and put it on a more stable basis than was the case when seeds were handled simply as a merchantable commodity with too little attention given to their agricultural value. It is not enough, however, that the seedsman alone should be well informed as to the quality of the seeds he is selling. He may know that a lot of redtop seed contains 15 per cent of timothy seed, or that a lot of crimson-clover seed contains 40 per cent of seed that will not grow, or that the red clover he is selling is imported from southern Europe, and is therefore poorly adapted to conditions in the red-clover growing area of the United States, but this information does not help the farmer unless the seedsman passes it on to him. The results of seed testing have been used by the seed merchant far too often for his own advantage, and not often enough to help the farmer. Since seed testing has now become so general that the seed trade as a whole has the information which the farmer needs in his business, it is incumbent on the trade to pass this information along with every lot of seed it sells.

The seed-trade associations, including in their membership nearly all of the seed dealers in this country, were formed to promote the individual and trade interests of their members, and self-protection will doubtless continue to be an important function of them. But the time has come when these associations must be more than self-protective. They must also help the farmer and turn their attention to means of improving agriculture.

At the suggestion of the Secretary of Agriculture, representatives of the seed trade met in Washington, D. C., in May, 1917, and agreed to label all lots of field seeds which they sold with the following information:

- (1) Name of seedsman.
- (2) Kind of seed.
- (3) Proportion of pure live seed present, with month and year of germination test.
- (4) Country or locality of origin in the case of the following imported seeds: Beans, soy beans, Turkestan alfalfa, and red clover from southern Europe and Chile.



In the spring of 1918, seed of red clover, crimson clover, and alfalfa was purchased from the trade and examined to determine the degree to which this labeling agreement was being carried out, with the result that only 10 per cent of the lots purchased were found to be fully labeled in accordance with the agreement. This failure on the part of the seed trade was called to its attention, and the greater number of seedsmen again agreed to label all field seed which they sold. Similar purchases were made in the spring of 1919, and an examination of these indicates that conditions were not far different from those found in the preceding year.

In the seed business both supply and demand are seasonal, with sharp fluctuations in price. There are few, if any, manufactured commodities which vary so much in price during a single year as does clover seed. This trend of the trade has made the seed merchant keen as to probable prices and speculative profits, when his attention should be directed to accumulating stocks of good-quality seed in quantities to meet local demands in time for seasonable use. The present speculative condition tends to keep the local dealer from buying in advance of actual sales, which results in a rush at the end of the season and a delay in getting the seed to the farmer at the proper planting time. While relatively large quantities of seed, especially red, crimson, and alsike clover and alfalfa, are frequently imported, such importations have generally not been effective in stabilizing prices but have served rather to furnish unusual profits to the importers.

It is known that red-clover seed from Italy is generally unsatisfactory for use in the United States as compared with home-grown seed or that from any other foreign country having a surplus for export. However, we do not know the extent to which the unsatisfactory condition of our red-clover crop in recent years is due to the large importations of southern European seed in 1915 and 1916. This seed is again being imported in large quantities. Enough to seed 800,000 acres, brought into the United States in the last six months, has been distributed throughout our clover-growing area, and for the most part this seed reaches the farmer without information as to its country of origin. This results from the possibility of large speculative profits, and clearly is not in the interest of good agriculture.

Before the seed trade can take its proper place in relation to agriculture, it must be governed less by speculative profits and more by an interest in the quality of the seeds that are bought and sold. The merchant must not withhold information of value to the farmer on the plea that the necessity for quick handling does not permit the necessary tests to be made, but he should give to the farmer full information about the seed he is selling, including the variety, the locality where it was grown, its freedom from mixture with other seeds, its weed seed content, and the proportion of it that may be expected to grow under favorable conditions. Until seedsmen do this they are not meeting the responsibility they owe to the fundamental industry of agriculture, on which their business is wholly dependent.

# HARNESSING HEREDITY TO IMPROVE THE NATION'S LIVE STOCK

By D. S. BURCH,  
*Editor, Bureau of Animal Industry.*

“DEAR SIR: I read your piece in regard to better sires,” writes a woman living on a farm in New Hampshire. “This is the first I have heard about it. Will you please send me particulars? Can I join? I keep purebred Ancona hens and I have a registered Duroc-Jersey boar. He is a beauty.”

“There are at present,” the letter continues, “no other purebred sires of any kind in this neighborhood and I shall try to get a purebred bull for service.”

The letter quoted indicates a number of current trends in live-stock improvement. It shows a recognition of the fact that the same principles of breeding apply to poultry, swine, and cattle, and of course to other live stock. It shows also that individual effort can make much progress even when community spirit is lacking. But the last portion of the letter, the most commendable part, shows a desire by getting a purebred bull for service to improve the quality of live stock in that locality. The “piece” referred to was a news item referring to the Federal-State “Better Sires—Better Stock” campaign inaugurated October 1, 1919.

## HEREDITY A USABLE FORCE.

Facts and figures gathered from numerous sources indicate that the Nation's live-stock industry has reached a stage of development where it will respond quickly to improvement in methods of breeding. Like gravitation and heat, heredity is a definite force that can be utilized to serve those who understand its laws and principles.

Heredity, however, differs somewhat from the force that moves the turbine or the steam engine in the manner in which it does its work, because heredity is a vital force while the others are chiefly of mechanical application. Yet one force can be harnessed quite as well as another if proper methods are used.

#### THE PRINCIPLE OF GRADING UP.

Of all the principles of breeding now established, probably the most important to live-stock owners having mixed stock is that of grading up. A good purebred sire when used with females even of scrub or mongrel breeding improves the uniformity, quality, and general value of the offspring to a marked extent. In addition, the improvement begun in one generation is carried on progressively to the succeeding progeny when the principle of grading up is skillfully applied. The progeny become more and more like the purebred stock and less and less like the original herd or flock. Grading up is a systematic, interesting, and economical method of live-stock improvement.

The United States contains more than 200,000,000 farm animals and, in addition, probably at least an equal number of poultry. The value and usefulness of this enormous quantity of live stock depends on certain qualities it possesses, and these differ according to species, breed, and type. With rare exceptions the most valuable qualities which live stock possess are found in selected individuals of the various standard breeds. That would be expected, of course, because the breeds were developed and perfected to meet definite, useful purposes. Thus, in horses we have the familiar racing breeds, saddle breeds, draft breeds, and others which fulfill general utility and intermediate purposes. Other kinds of live stock also include many classes and specially developed types.

Those live-stock owners who have given the study of certain kinds of animals special attention are chiefly responsible for keeping domestic stock in well-defined classes. To such breeders credit likewise is due for well-kept records of production and for most of the improvement that has taken place. But notwithstanding the development of a small percentage of well-bred stock, most domestic animals

in the United States are of mixed or indefinite breeding, and a large majority lack records of their breeding.

#### BETTER BREEDING AND ECONOMIC PRESSURE.

Such stock was useful enough in pioneer days, when competition was less keen, when feed was more plentiful, and market requirements were less exacting. But with present economic pressure for reduced costs of production and a quicker turnover on money and labor invested, better breeding becomes almost essential. To-day mixed stock exists largely perhaps as an agricultural habit. The benefits resulting from improved live stock have not been fully realized, facts about heredity as applied to live stock have not been readily available, and a small percentage of inferior purebred animals may have raised some doubt in the minds of farmers as to whether purebred stock actually was better than the kind they already had.

To give dependable information on the points mentioned, a movement known as the "Better Sires—Better Stock" campaign has been undertaken and is now in effect. Sponsored jointly by a majority of States and by the United States Department of Agriculture, the movement encourages the general use of purebred sires in all the principal classes of live stock. The classes are: Cattle, horses, asses, swine, sheep, goats, and poultry. The campaign also provides official recognition for live-stock owners who use purebred sires of good quality. (See illustration, p. 350.) Whether female breeding animals also should be purebred depends largely on the skill of the breeder, the kind of farming followed, and numerous local factors. Purebred sires, however, are advised under all conditions.

#### PUREBRED, CROSSBRED, OR GRADE—TAKE YOUR CHOICE.

The use of purebred sires will give purebred, grade, or crossbred offspring, depending on the kind of female stock used. If the female is purebred and of the same breed, the offspring of course will be purebred. If the female is scrub or a grade but the male parent is purebred, the offspring will be a grade. If the female is purebred but of a breed different from the sire (though of the same species), then the offspring will be crossbred. Thus it is clear that the user

of purebred sires may obtain any or all of the three kinds of progeny, depending on the kind of female stock kept and on individual preferences. He need not become a breeder of purebred stock unless he chooses to do so, but by the use of purebred males for breeding he at once ceases to raise scrubs.

The forces of heredity are always at work in live-stock breeding, and when little or slight attention is paid to them the results are uncertain. The various characteristics which



Facsimile of the First "Better Sires—Better Stock" Emblem Awarded in the Federal-State Campaign for Live-Stock Improvement.

This emblem, which is a combination of certificate and poster, is granted to all who use only purebred sires in raising live stock and who enroll.

parent stock of mixed breeding possess serve to blend with or offset one another, thus making evolution slow—so slow in fact that improvement can scarcely be seen within the lifetime of the breeder. On the other hand, careful selection of breeding stock and its systematic use are steps in harnessing the vital forces of heredity to bring about improvement that quickly becomes visible to the eye and is profitable in many ways.

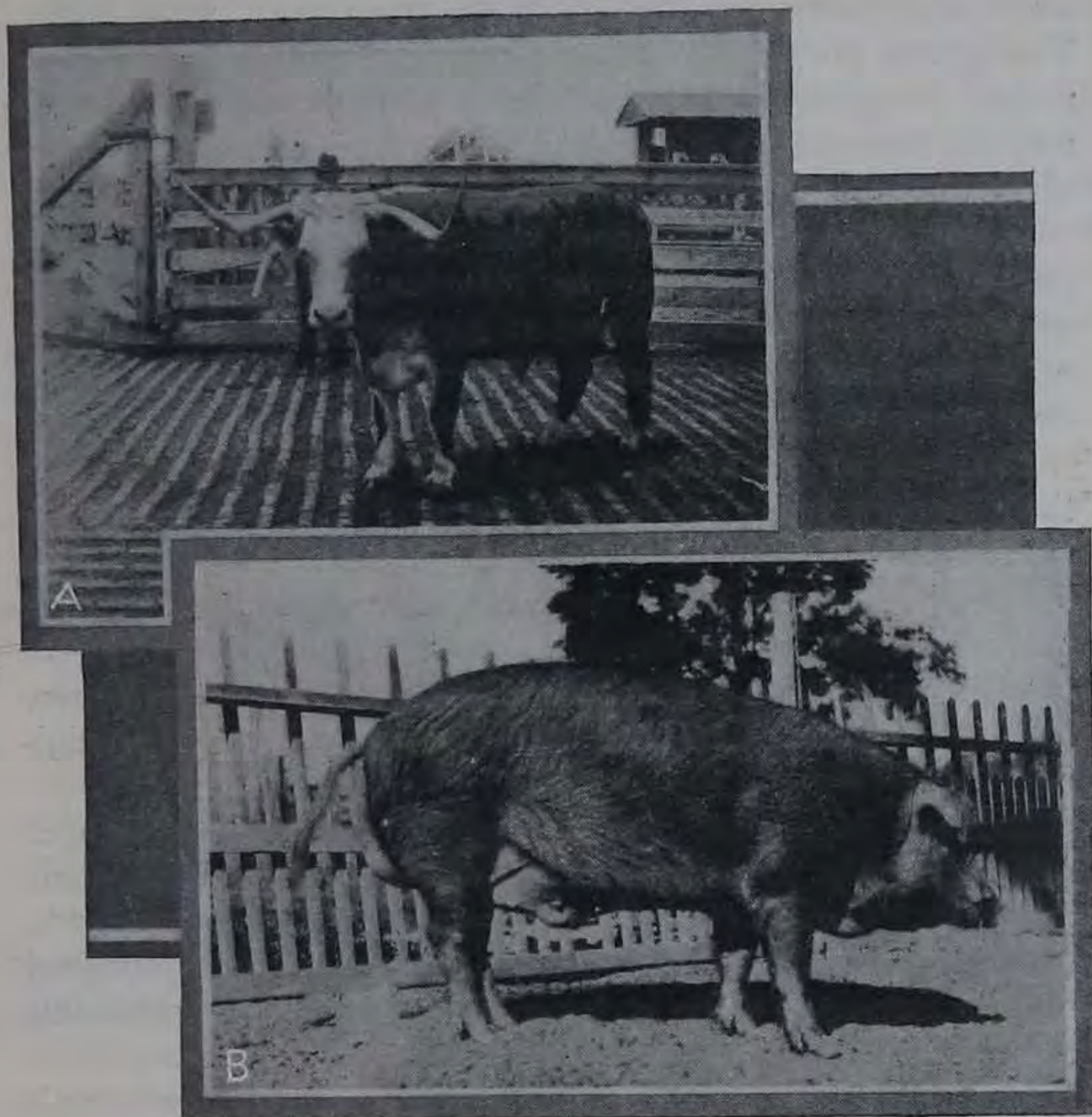

An Unusual Grade Steer and a Purebred Yearling Boar.

A. An interesting result in grading up from native stock. This animal is a first-cross steer resulting from a longhorn cow and a purebred Hereford bull. The steer brought within 50 cents a hundred of the top price on the Chicago market the day he was sold. (By courtesy of the Wisconsin College of Agriculture.)

B. Herd boar, as a yearling, of T. Y. Williford, of Georgia, the first person to enroll in the better-sires movement. The use of purebred sires in all classes of animals kept is the only requirement for enrollment, and every livestock owner is eligible.

#### EXAMPLES OF HEREDITY AT WORK.

Of definite results collected by experiment stations and the United States Department of Agriculture, the following are typical:

Compared with beef steers sired by scrub bulls, steers sired by purebreds have been found to be worth \$10 more at 6 months old, \$20 more at a year old, and \$30

more at 2 years old than beef steers sired by scrub bulls. The figures are round numbers and represent average conditions. In general the use of purebred bulls with scrub cows may be expected to add one-third to the value of steers because of their better and more economical growth and quality.

Lambs sired by a purebred ram compared with the progeny of a scrub provided the following facts: They made greater gains in less time and at less cost for feed. Because of better finish as compared with thin, rough, scrub lambs they brought nearly 75 per cent more on the market.

Purebred or grade dairy cows have frequently earned for their owners from one-fourth more to over double the returns received from scrubs. In a typical case heifers sired by purebred dairy bulls surpassed their dams, which were ordinary cows, by 52 per cent in butterfat and 64 per cent in milk production. The second generation produced more than twice as much in both butterfat and milk as the original cows.

Average pigs sired by a purebred boar will weigh at maturity fully 25 pounds more than pigs sired by a scrub or grade. Considering size and quality of the carcass in connection with cost of production, pigs sired by a purebred may be expected to be at least 15 per cent more profitable than those having scrubs or grades as male parents.

In poultry, fowls of the meat and general-purpose breeds usually weigh at least 25 per cent more when ready for market than common mongrel stock. In a North Carolina experiment the use of a pedigreed high-production male increased the average egg yield of a flock of pullets 54 per cent, as compared with their dams of inferior parentage.

#### BETTER BREEDING WILL SAVE A BILLION DOLLARS.

To some live stock owners the better quality of well-bred stock is sufficient reward through the satisfaction of having produced superior living creatures. But to others, probably a majority, the financial benefits are important inducements to live-stock improvement. Cases like those mentioned indicate that fully 25 per cent may be added to the market value of live stock and its products because of greater production, better quality, or added uniformity obtained through the use of purebred sires. To allow for the animals of good breeding



already present in the United States, let us reduce the figure from 25 per cent to 20. Next, to satisfy any persons who may question whether the figures are typical, we may cut the 20 per cent in two, leaving 10 per cent. But even this conservative figure applied to the 10 billion dollar live-stock industry shows that a round billion dollars is lost because heredity has been permitted to work with too little control.

The "Better Sires—Better Stock" movement, in which 43 States are now cooperating, is aimed to reduce this billion-dollar loss, which averages close to \$200 annually for every farm where live stock is kept. With better breeding there arises also, as a logical consequence, interest in feeding and care. More than that, the thought devoted to wise animal-breeding methods encourages similar thought in the raising of farm crops through seed selection and study of improved methods. Thus the benefits extend in many directions and overlap in places. Civil engineers have harnessed rivers and waterfalls to make agriculture possible in regions marked as deserts on old maps. Explorers have traveled thousands of miles to find many kinds of plants and animals that will enrich our agriculture. But opportunities frequently overlooked are also nearest home. Through attention to the forces of heredity, present in every animal kept for breeding, the live stock of the United States may become more profitable to the breeder and useful to the public.

#### ENROLLMENT OF FIRST THREE MONTHS.

The records of enrollment less than three months after the better-sires movement was inaugurated included 6,200 animals, principally cattle, swine, and sheep in the order stated, besides 8,949 fowls. In supplying the desired information regarding the kind and breeding of their stock, the owners in many cases furnished supplementary information of interesting character.

A point of noteworthy interest is the fact that the use of purebred sires apparently leads to the ownership of at least one and frequently several purebred females.

Flocks and herds of many sizes are represented. The different classes of animals are kept in various combinations, but there is a noticeable tendency for cattle and hogs to form an almost inseparable alliance. That is a matter of

common observation and experience, but as the better-sires movement develops there should be more definite facts on the subject.

The slogan "Better Sires—Better Stock" was suggested by a dairyman in Idaho. Granting a definite form of recognition for the use of purebred males was developed from a Wisconsin plan. Practically every State shares in the inception of the effort to bring about a more general use of the forces of heredity that can so easily be made to work for live-stock owners with benefit to the entire Nation.

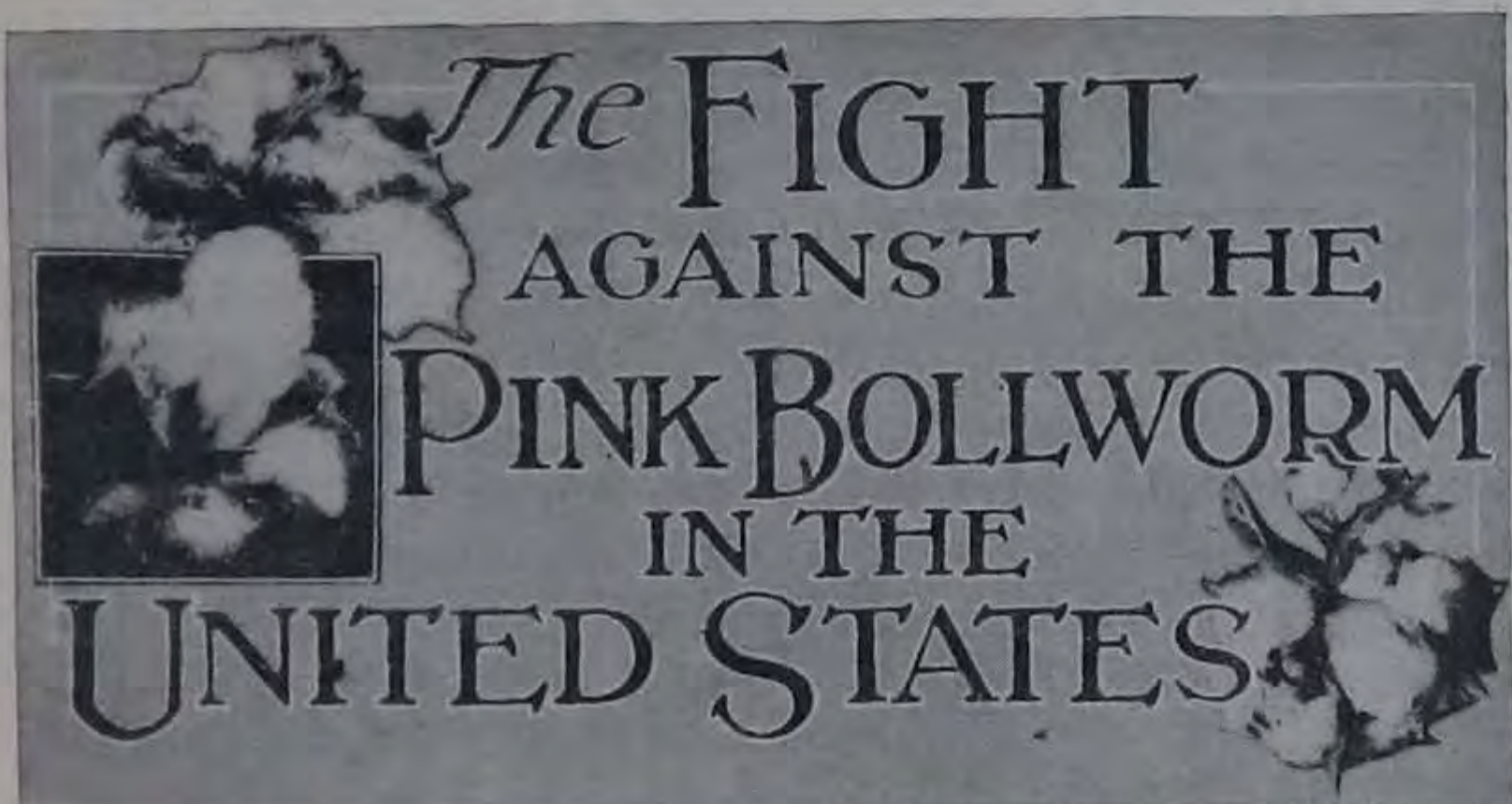

*The* FIGHT  
AGAINST THE  
PINK BOLLWORM  
IN THE  
UNITED STATES

By W. D. HUNTER,

*Member of Federal Horticultural Board; in charge of Southern Field  
Crop Insect Investigations, Bureau of Entomology.*

THE PINK BOLLWORM A MENACE TO COTTON GROWING.

UNTIL about 50 years ago the devastation caused by the so-called cotton caterpillar was an important factor in limiting the cotton crop of the United States. About 28 years ago a much more destructive pest, the boll weevil, entered the country from Mexico. It has spread year by year until it now occupies the greater part of the cotton belt. Its advance has been marked by incalculable losses which have affected the entire industrial structure of the South. It is with natural concern therefore that the planters of the South face the possibility that still another very destructive cotton pest may become established in this country. This is the pink bollworm, which has already become established in India, Egypt, Brazil, China, Mexico, and other cotton-producing countries.

The establishment of the pink bollworm in the United States would be all the more important because of the presence of the boll weevil here. The boll weevil does not occur outside of the North American continent and the island of Cuba, and it has already placed an important handicap on the producers of this country in their competition with planters in other parts of the world. To suffer the further loss which would be caused by the presence of the pink bollworm would greatly weaken the position of this country as a cotton producer.

The pink bollworm is probably the most serious pest of the cotton plant in the world. It reduces the yield, lowers the quality of what is produced, and affects the seed as well as the lint. Because of its work, the farmer loses a portion of his crop, the spinner is supplied with inferior material, and the miller obtains lower grades of by-products. Although probably of tropical origin, there is no reason to suppose it would not maintain itself in the United States. In fact in one locality in Texas it has withstood temperatures of zero and slightly lower.

One peculiarity in the life history of the pink bollworm greatly favors its spread. This is the fact that the larvæ in the last stages make their way into the interior of the seeds and may live there for as long as two years. In an experiment to determine how long the insect will live in bales of cotton, an investigator of the Department placed numerous larvæ in miniature bales in Honolulu several years ago. At stated intervals individual bales were opened. The last bale was opened 26 months after it had been pressed, and living larvæ were found in this bale as well as in every bale previously opened. This remarkable longevity makes it possible for the pink bollworm to be transported in seed to the remotest parts of the earth.

#### QUARANTINE MEASURES.

The pink bollworm was one of the first insects considered when the plant quarantine act went into operation in 1912. This act gave the first means at the disposal of the Department of Agriculture for preventing the introduction of serious insect and plant diseases by quarantines and restrictive measures. At that time considerable quantities of cotton seed from foreign countries were entering the United States. The first step taken therefore was to place an embargo on cotton seed from foreign countries, except northern Mexico. Later it was discovered that considerable quantities of seed were being brought in in bales of lint. In fact, on one occasion, a specimen of the pink bollworm was found in picker waste from Egyptian cotton which was being milled in Georgia. This discovery led to very serious consideration of means of disinfecting baled cotton. After protracted

experiments a system of disinfecting cotton by a vacuum process and the use of hydrocyanic-acid gas was evolved and placed in operation at the ports of entry.

The first steps taken by the Department through the Federal Horticultural Board to prevent the entry of the pink bollworm into the United States included the following:

(1) The exclusion of cotton seed from all foreign countries except the Imperial Valley of Lower California, and restricted entry from certain northern States of Mexico.

(2) The exclusion of cotton seed from the Territory of Hawaii.

(3) The regulation and safeguarding of the cottonseed products from all foreign countries and Hawaii.

(4) The regulation of the entry and disinfection of all imported cotton and cotton waste and also materials which have been used as wrappings for foreign cotton.

#### DISCOVERY IN MEXICO.

The precautions enumerated above were in operation in 1916, at which time it was not known that the pink bollworm had become established on this continent. In November of that year, however, specimens of this pest were received at Washington from a planter in the Laguna of Mexico. Up to that time cotton seed from Mexico had been admitted to the United States from the northern States of Mexico, where the cultures of cotton are frequently more or less continuous with those in the United States. With respect to Lower California, cotton seed was admitted under permit without restrictions as to use. With respect to certain other States of Northern Mexico, cotton seed was admitted under permit for milling only, at mills in Texas. As soon as the infestation in Mexico was discovered an embargo was promulgated stopping further entry of Mexican seed excepting that from Lower California, and steps were taken to regulate all freight and other traffic from that country, to prevent the accidental carriage of seed with such cars and freight.

Through the accident of disturbed conditions in Mexico during the months before the embargo was promulgated on November 3, 1916, large quantities of seed were shipped into the United States. Altogether, 446 carloads had entered the United States during 1916 prior to November 3. This

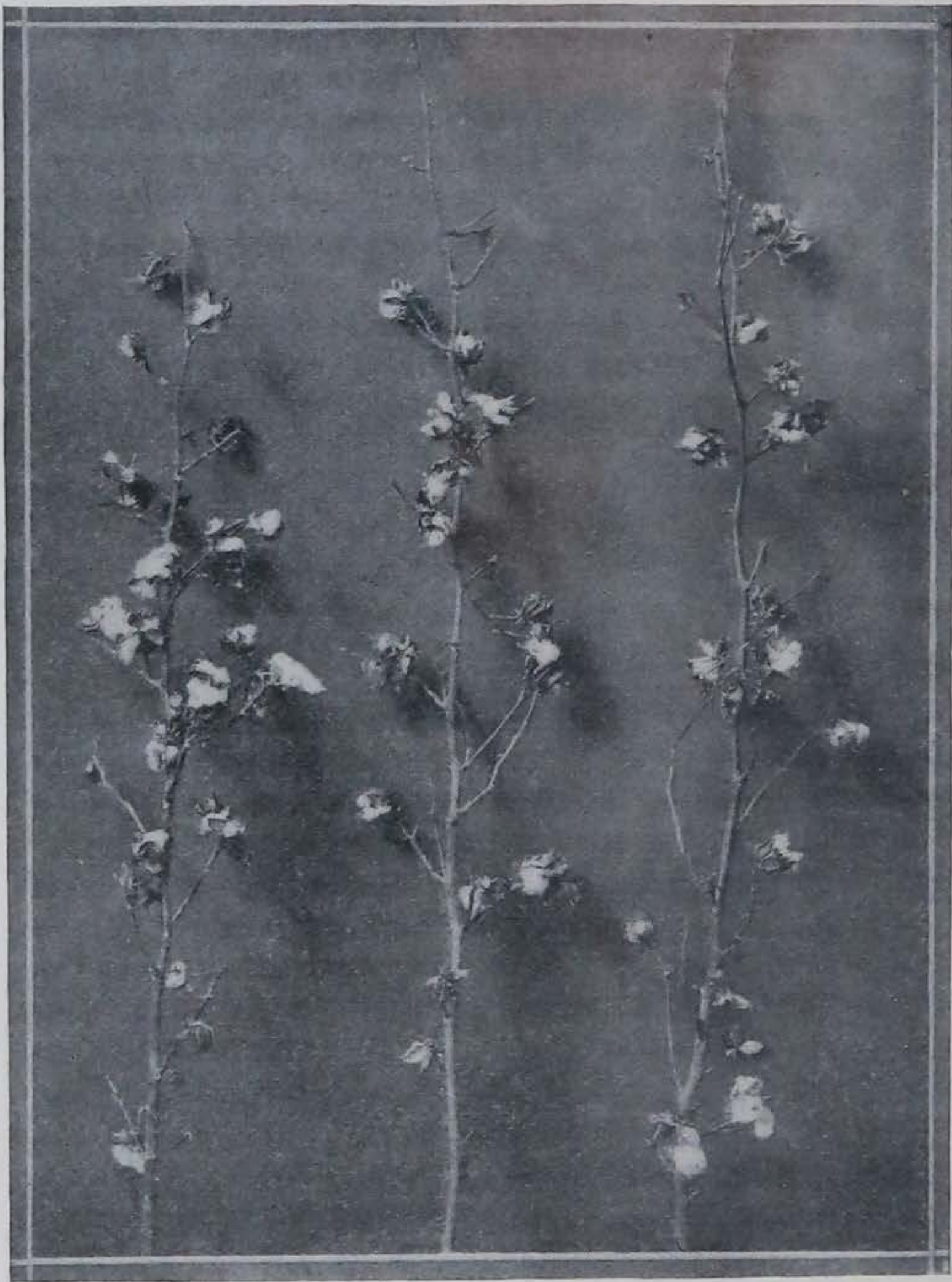

Injury to Top Crop.

Photograph taken in Mexico showing extent of injury by pink bollworm to top crop. All of the bolls are practically worthless. (Photograph by U. C. Loftin.)

seed went to 11 mills distributed more or less throughout the important cotton districts of Texas.

In cooperation with the State authorities of Texas and other offices of this Department, the Federal Horticultural Board immediately took steps to safeguard this Mexican

seed. These steps consisted of the early crushing of the seed, the cleaning of the mills and premises, and the disposal of the by-products in the ways least likely to cause infestations to become established.

#### THE PEST FOUND IN TEXAS.

In 1917 intensive examinations were made in the vicinities of all the mills which had received the Mexican seed. No infestation was found until September 10, when specimens were discovered in a field at Hearne. Later infestation was found in the vicinity of Beaumont, and about the same time at Smith Point, Anahuac, and other points around Trinity Bay.

The infestations at Hearne and Beaumont were clearly due to the receipt of Mexican seed. The infestation around Trinity Bay appears to have been due to the washing ashore and breaking of bales of Mexican cotton which were on the docks at Galveston at the time of the hurricane of August 15, 1915.

#### PROTECTIVE MEASURES AT MEXICAN BORDER PORTS.

As soon as the presence of the pink bollworm in Mexico was known the Federal Horticultural Board inaugurated a system of inspecting and disinfecting all freight and vehicles which might convey the insect in any stage across the Rio Grande. Inspectors were placed at all of the ports of entry. This service was greatly strengthened during 1919 by the erection of fumigating houses to accommodate freight cars and other vehicles. These are located at Brownsville, Laredo, Eagle Pass, Del Rio, and El Paso. Their use will be much more satisfactory than the former system of fumigating the interior of cars with hydrocyanic-acid gas and spraying the exterior with kerosene.

This work was supplemented by stationing special agents at the international bridges to inspect hand baggage. This is an important point of danger, since about 15,000 laborers from the interior of Mexico annually come to the States of Texas and Arizona to pick cotton. In several instances, living specimens of the pink bollworm were intercepted in seed cotton in personal baggage which had been brought to border ports.

## THE TEXAS PINK BOLLWORM ACT.

Even before any infestation by the pink bollworm had been discovered in Texas, the legislature considered a law to prevent the invasion of the State. The main idea which was considered was to grant authority for the establishment of a noncotton zone along the Rio Grande wherever that should become necessary. However, the framers of the act wisely included provisions for the handling of any infestation which might at any time be found within the State. It was while this act was being considered, and after its passage was assured, that the infestation at Hearne was found.

The Texas pink bollworm law, which was originally approved on October 3, 1917, and amended and greatly strengthened by reenactment on March 10, 1919, contains a number of features which are unique in American legislation regarding insect pests. The statute is broad and comprehensive, and much credit therefor is due to its author, Leonard Tillotson, of Austin County. The essential features of the law are the designation of a zone including all of the counties along the Rio Grande which may be constituted a noncotton zone upon the certification of the commissioner of agriculture and the proclamation of the governor when near-by infestation is found in Mexico. Looking toward the eradication of the pest in the interior of the State, authority is given to establish noncotton zones or zones in which the planting of cotton is allowed under restrictions. Whether a noncotton zone or a permissive zone is established depends upon the recommendation of a commission of entomologists, consisting of one designated by the commissioner of agriculture, one by the governor of the State, one by the Agricultural and Mechanical College, and one by the United States Department of Agriculture. The report of the commission, under the law, determines the action which the commissioner is to take. The decision of the commission is certified to the governor by the commissioner of agriculture, and it becomes the duty of the governor to issue the necessary proclamation in accordance with the recommendation of the commission. In case it is necessary for the State to destroy any growing crops in a restricted zone or in any portion of the State where there are no restrictions, compensation to the owners is author-



ized. The amount of compensation is fixed by a committee of three disinterested citizens appointed by the county judge in the county involved. The penalties for violating any of the provisions of the law or any orders or regulations which may be promulgated thereunder are specific and heavy, ranging from \$500 to \$5,000, and each act in violation of the law or regulations is constituted a separate offense.

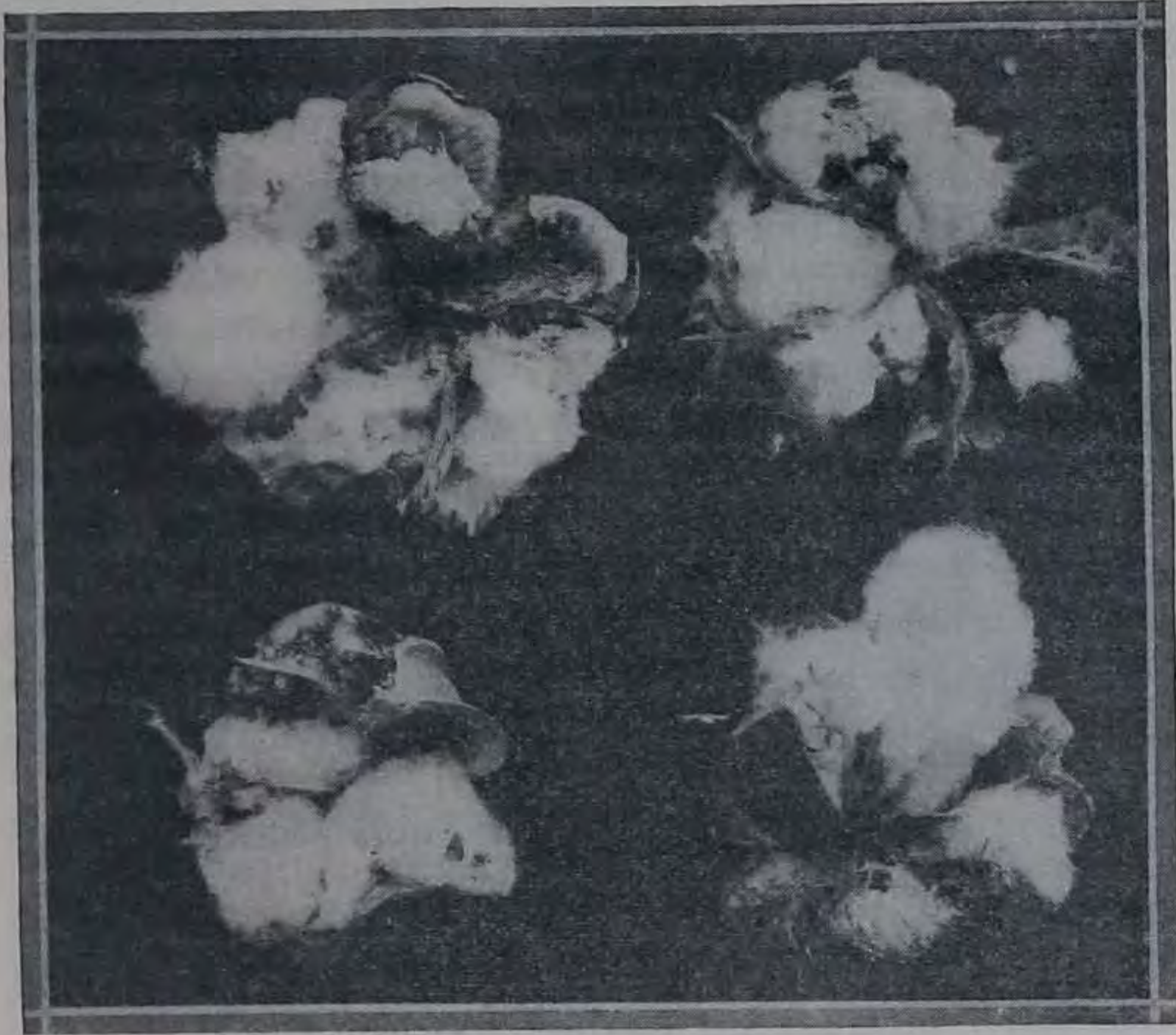

Pink Bollworm Injury.

Bolls showing characteristic injury by pink bollworm in Mexico. (Photograph by U. C. Loftin.)

The constitutionality of this law was tested in 1918 in a case brought by the State against persons who had planted cotton in a proclaimed noncotton zone. The statute was attacked on the score that it was unreasonably drastic and provided measures such as noncotton zones which were more destructive to the community and to the State than the pest it was intended to eradicate. The case of the State was very ably handled by John C. Wall, assistant attorney gen-

eral, in cooperation with J. D. Williamson of the Texas Cotton Association. After the most minute consideration of the extent of the police powers of the State, the court decided that the statute was valid and ordered the destruction of the cotton being grown in violation of law.

#### METHODS OF DEALING WITH OUTBREAKS IN TEXAS.

Operating under the law which has been discussed, and with the active support of the commissioner of agriculture, Fred W. Davis, for the State of Texas, the State and Federal Departments in the fall of 1917 undertook to stamp out the infestation. The plan followed included the determination of the exact extent of the infestation, the safeguarding of the cotton and seed produced, and the cleaning of the fields. In addition to the inspectors of the Federal Board, a large number of agents were transferred temporarily from the Bureau of Entomology, giving a force of over 50 inspectors. The cooperation of the railroads and handlers of cotton rendered it comparatively easy to have all of the lint in infested areas exported and all the seed shipped to Houston for crushing under supervision. The work of cleaning the fields was done as rapidly as possible. The maximum force employed consisted of about 1,000 laborers. Altogether 8,794 acres of cotton lands were cleaned at a cost of \$87,439.88.

Following the clean-up work, noncotton zones were established at Hearne and in the Trinity Bay section of southeastern Texas. The former included a radius of 3 miles around the mill where the original infestation was found. The latter included the territory between the Brazos and Neches Rivers, comprising all or parts of seven counties. The area was about 125 miles long by 50 miles wide, nearly as large as the State of Connecticut. In this area a safety zone approximately 10 miles wide was provided in the noncotton zone beyond the outermost points found infested.

Acting under another provision of the law, a noncotton zone was also established on the Rio Grande including Kinney, Maverick, and Val Verde Counties, an area of 5,646 square miles. This action was taken on account of the discovery by agents of the Federal Horticultural Board of infestation in Mexico within 25 miles of the Texas boundary.

OBSTACLES ENCOUNTERED.

The enforcement of the noncotton zone in southeastern Texas in 1918 was fraught with many difficulties. There had been two years of dry weather which had given many farmers the impression that cotton was a crop well adapted to the area included in the noncotton zone, whereas, as a matter of fact, extended experience has shown that under normal conditions the region is not well adapted to the planting of cotton. On this account and on account of an early test case which revealed a defect in the law, which has now been corrected, a large number of fields were planted in the noncotton zone. This led to the thorough test of the law to which reference has been made. The legal complications extended throughout the summer of 1918, so that the final determination of the validity of the law was not made until after the outlaw crop had been produced. The matter was adjusted by the turning over of the lint and seed produced in violation of



Injury to Partly Opened Boll.  
Cotton boll showing nature of injury by pink bollworm.

law to the State for marketing under safeguards. This was covered by formal agreements entered into by the farmers. These agreements also surrendered the right of injunction against the State in further proceedings for the enforcement of the law and in other respects placed the farmers in a position where they could not commit further violations.

NO INFESTATION FOUND IN 1918.

Throughout the season very extensive field inspections were made in the three noncotton zones. These inspections included the examination of all volunteer cotton, all cotton being unlawfully grown, and the fields immediately outside of the noncotton zone. In the Trinity Bay

section 3,284,602 volunteer plants with 276,247 bolls were examined during the season. In only one case was any volunteer cotton allowed to grow. This was at Smith Point, where the heaviest infestation ever found in Texas was discovered in the fall of 1917. During the following year no cotton was planted within 50 miles of Smith Point. As a measure to determine whether the insect had been reduced in numbers or stamped out, 51 volunteer plants were allowed to grow in the field which had previously been found to be heavily infested. These plants were examined with the utmost care throughout the season. In the fall all of the seed cotton was picked and the contents of every lock, including every seed, were carefully scrutinized. The outstanding feature of all this work of inspection was that no specimens of the pink bollworm or signs of its work were found in any of the three noncotton zones. This indicated that the pest had been very greatly reduced, if not eradicated. At any rate it was perfectly clear that the infestation was infinitely less than in the fall of 1917. The State and Federal departments, therefore, decided as an experiment to allow the planting of cotton in this area under restrictions during 1919, and this plan was placed in operation. The restrictions included the use of seed from uninfested localities, the marketing of the products under supervision, the cleaning of the fields in any manner prescribed by the commissioner of agriculture, and other supplementary safeguards.

#### DISCOVERY OF INFESTATION IN WESTERN TEXAS.

Late in 1918 several fields in the so-called Big Bend in the western part of Texas were found to be infested by the pink bollworm. This infestation evidently originated in adjacent portions of Mexico. It was found that in one instance a wagonload of seed cotton which had been smuggled across the river in the Big Bend was carried about 200 miles overland to Barstow in the Pecos Valley. Careful scouting at that place revealed another infestation. Altogether in the Pecos Valley 14 specimens were found in seven fields. Thirteen of these specimens were dead. The cleaning of the fields was immediately undertaken in the Pecos Valley. Four thousand two hundred and forty-

nine acres were cleaned. This included an area from 3 to 4 miles beyond any fields which were found infested. In the Big Bend all of the fields in Brewster and Presidio Counties, aggregating 508 acres, were cleaned.

#### WORK OF 1919.

The work of the season of 1919 consisted of maintaining three noncotton zones and two restricted zones. The noncotton zones were at Hearne and on the Rio Grande. In the latter locality the zone including Kinney, Val Verde, and Maverick Counties was continued, and another including Brewster and Presidio Counties was organized. The reasons for establishing a restricted zone rather than a noncotton zone in the Trinity Bay section have been given. There were several definite reasons for establishing a restricted rather than a noncotton zone in the Pecos Valley. In the first place, the region is isolated, as no other cultures of cotton are found within 100 miles. The infestation was slight, and the clean-up work was more thorough on account of local conditions than had been possible in any other locality. Another consideration was the fact that on account of peculiar conditions in the Pecos Valley cotton is the only crop which can be planted in the spring. If a noncotton zone had been proclaimed something like 3,000 acres of land would have remained idle, with consequent disaster to the community.

A corps of about 75 inspectors was organized to make examinations throughout the restricted zones and in the cotton immediately adjoining them. These inspections also included the examination of all volunteer cotton found in noncotton zones and of the cotton planted contiguous to them, as well as fields growing in the neighborhood of the 11 mills which received Mexican seed in 1916, in addition to others which for any reason were under the least suspicion. All of these examinations gave negative results until October 17, when a specimen was found in southern Jefferson County. In later examinations 43 fields have been found infested in the Trinity Bay section, as against 157 found infested in the winter of 1917-18. No infestations have been found outside of the restricted zone in this part of the State or elsewhere in Texas.

In the Pecos Valley one specimen was found on November 12.

It is interesting in this connection to note the amount of scouting which resulted in disclosing the infestations of 1919. In the Trinity Bay section over 1,500 man-days have been devoted to the work. In the case in the Pecos Valley



Cleaning Cotton Fields.

Lower: First step in cleaning cotton fields. In this case grubbing hoes are being used, but whenever the soil is not too dry the plants are pulled out by hand.

Upper: Last step in cleaning cotton fields, showing removal of all vestiges of the cotton plant from the ground.

209 man-days were spent in the very field which was finally found infested. After the single specimen had been found over 100 additional man-days were spent in examining the field with negative results.

The very large amount of scouting done indicates clearly that the infestation in 1919 is much less in extent and intensity than it was in 1917. In other words, the attempt

at eradication seems to have been along the right lines, although the results were far short of what was desired.

#### PROBABLE EXPLANATION OF RECURRENCE.

It is evident that there is no relation between the outlaw cotton of 1918 and the infestations which have developed. A number of them are in fields which are distant from 40 to 50 miles from where any cotton was planted in 1918. The reason the insect lived over a one-year non-cotton period is somewhat obscure, but it is probable that larvæ had fallen to the ground in seed cotton dropped from the plants and been more or less covered with earth at the time of the clean-up. Although tests have shown that the process of cleaning fields is more than 99 per cent efficient, yet, with the large area to be covered and the class of labor available, some infested material is undoubtedly left on the ground. The records obtained in Egypt and in Honolulu by August Busck indicate that the pink bollworm larva may live for two years. Its longevity is especially great under dry conditions. The season of 1918 was dry throughout Texas. This seems to have favored the prolonging of the larval stage of those insects which were missed in the clean-up of the winter of 1917-18, and it is conceivable that if 1918 had been a normal season the insects would all have emerged and in the absence of cotton would have perished.

The possibility that the infestation lived over in plants other than cotton has received very special consideration. During the noncotton year many thousands of seed pods of okra and of wild malvaceous plants related to cotton were examined. Altogether over 2,000 man-days were devoted to this work in the immediate vicinity of fields where heavy infestations were located in the fall of 1917. Such inspections were continued during 1919. In fact a number of special investigators were placed in the immediate vicinity of the fields where infestation was found in 1919 for the purpose of examining okra and other malvaceous plants. The work of agents of the board in Mexico and investigators in Egypt has shown that under some conditions the pink bollworm will maintain itself on plants other than cotton. That this is the explanation of the recurrence of the pest in southeastern Texas seems to be abundantly disproven,

however, by the large mass of negative evidence obtained in places where, if there had been any breeding in plants other than cotton, it seems certain that it would have been discovered.

#### FUTURE PLANS.

Taking all of the work which has been done in Texas into consideration, three facts are of outstanding importance. The first is that the quarantine and restrictive measures appear to prevent the spread of the pest, the second that the clean-up measures adopted greatly reduce the infestation, and the third that the clean-up measures and a noncotton zone of one year combined are not sufficient to stamp out the pest.

It is proposed, therefore, to continue the work along the original lines indicated in this paper and to recommend to the State authorities that in every case a noncotton zone should be maintained for a period of not less than two years.

For several reasons the present work of cleaning the fields will undoubtedly be much more effective than the earlier work of the same kind. For one thing the infestation has been discovered earlier and is lighter than before. Moreover the amount of cotton produced per plant during 1919 has been a great deal less than in 1917. This gives a much smaller volume of possibly infested material to fall to the ground and pass beyond recovery. Another important consideration is that the wet season of 1919 has caused an abundant growth of grass and weeds in fields throughout the infested territory. This will make it possible to burn over the fields much more effectively than was possible in 1917.

The stamping out of the pink bollworm in the United States is an undertaking of great magnitude. The territory in which measures must apply aggregates over 22,000 square miles. The unusual longevity of the larva is an important obstacle, and there are naturally many legal and administrative difficulties. Nevertheless, the general situation is rather encouraging and there still seems to be a possibility that the plan of operation which is being followed may prevent the establishment of an exceedingly destructive pest in this country.



# SELLING PUREBRED STOCK *to* SOUTH AMERICA



By DAVID HARRELL, *Live-Stock Commissioner*, and H. P. MORGAN, *Assistant in Marketing Live Stock and Meats, Bureau of Markets*.

THE rapid development of the purebred live-stock industry in the United States has produced a surplus of registered animals well adapted to the use of South American breeders. As most of our animals are raised under climatic conditions closely resembling those found in South American countries, and as 60 to 90 per cent of the total industry of the east coast countries of South America is directly connected with live stock and animal products, the position the United States is prepared to assume in the resulting trade in purebred live stock is obviously of great interest to breeders in this country.

The Bureau of Markets has attempted to ascertain to what extent a foreign market is available for purebred live stock originating in the United States, and for this purpose the authors have made a personal investigation during the present fiscal year covering conditions in Brazil, Paraguay, Uruguay, Argentina and Chile.

Certain obstacles are to be overcome before satisfactory relations will be established, but first-hand observations would lead to the conclusion that they are not as difficult as

they seem. Many of them are the drawbacks which must be overcome when undertaking export business for the first time with any country.

It is to be expected that all animals which enter the east coast countries will contract foot-and-mouth disease before the expiration of the 30-day quarantine period. In normal years this is looked upon as a 10-day illness with light mortality. The fact that 1919 has been a year of unusual loss has stimulated study of this disease. Methods of isolation and quarantine as practiced in the United States are of no avail.

The cattle tick is found in all countries of the East Coast, and, with the exception of the lower part of Uruguay and Argentina, all stock imported into these countries will have to combat tick fever. There is a growing interest in eradication and control methods, especially on the ranches where improved stock is raised, but the prevalence of the tick is a serious matter.

The present lack of direct business connections is unfortunate. Permanent trade is best developed by means of connections with firms well known in the country of import or through permanent colonists from the country of export. The fact that so few North Americans as compared with Europeans are now engaged in the live-stock business in these countries is a serious handicap. All of these obstacles, however, can be overcome by good business methods.

The leading South American live-stock shows will be of great assistance as an advertising medium. Live stock bred in the United States may be exhibited there and will be viewed by large numbers of breeders who are prepared to purchase high-class stock either through the auction ring (the favorite method in South America) or through private treaty. The attitude of the breeders is open-minded, and purebred stock exhibited by our exporters will receive the attention it merits.

A desirable method of procedure, especially in Argentina and Uruguay, is through consignments to local auction companies of established reputation. If the early shipments are of a high character, demand can be developed, volume of business secured, and an opening made toward direct shipment later.

Advertising should be very carefully prepared, both as to subject matter and as to translation. A campaign making extravagant claims which can not be fulfilled except under the most favorable circumstances would do more harm to the entire live-stock trade with the United States than could be offset by several successful importations.

Careful study should be made of the conditions in the several countries offering the greatest opportunities. Very general considerations are given here, and further information is available upon request addressed to the Bureau of Markets at Washington. The breeders of the United States are generally adaptable in their business methods, and this fact should be in their favor. Once the conditions are thoroughly understood, effort should be made to meet the requirements, every allowance being made for difference in language and custom and consequent chance for misunderstanding. A shipment of high-class stock selected especially to meet the specific needs of the importer, coupled with unusual care in methods in order to prevent disappointment, should pave the way for a successful future business. Cooperation between cattle, sheep and swine breeders may be made effective in conducting adequate advertising campaigns, in securing satisfactory shipping conditions and in developing volume of trade.

It is essential also that South American buyers be encouraged and assisted by every practicable and consistent means to make their own selections of stock in the United States. A substantial beginning in this direction already has been made through our own shows and record associations, as well as by the Department of Agriculture, and present prospects are highly favorable for the future development of this class of business.

#### BRAZIL.

Brazil is of about the same area as the United States and in part has a climate well adapted to stock raising. The Government has recently taken steps to lend encouragement and aid to breeders desiring to import purebred live stock, and improvement on a national scale has begun. One decree provides for the reimbursement to shippers of the freight from the port of debarkation to the destination.

Another law provides for advancing one-half of the purchase price to bona fide stock raisers who order through the Government at a stated time each year. Several model stock farms have been established throughout the country where practical suggestions are given, improved practices are demonstrated and purebred live stock is offered to purchasers in limited numbers. These governmental aids have given great stimulus to the industry.

The large packing companies of the United States maintain development departments through which importations are made and advice and information are given to interested breeders. The close of the war caused a decrease in the demand for meat which has made possible a greater discrimination in price between unimproved and well-bred stock and which is expected to provide an additional impetus to the improvement of the live stock of Brazil. The necessity for introducing new blood and employing better methods of handling is already apparent to a relatively large number of the breeders, and those who supply the best information and make the process of importing most attractive to buyers will have the greatest success in supplying Brazil with purebred live stock.

The largest undertaking in the importation of purebred stock has been carried on by one of the domestic land and packing companies. Several hundred cattle and hogs have been imported in an attempt to raise purebred stock on a commercial scale. A large amount of experimental work relating to breeds and methods of handling has been done by this company. The agricultural school in connection with the mission at Lavras, in the State of Minas Geraes, also has been breeding cattle and hogs, as well as studying the best means of improving the general condition of the live-stock industry in Brazil. The results of these activities indicate that purebred live stock from the United States will be effective in the improvement of the live stock of Brazil.

Attempts of breeders of the United States to develop a trade with Brazil will probably be met with an open mind. Generally speaking, Brazil is not in a position to receive our show winners nor the highest-bred animals, but rather, well-bred animals of the best type raised under pasture conditions. Similarly, the highest prices can not be expected immediately. The principal demand is for result-producing

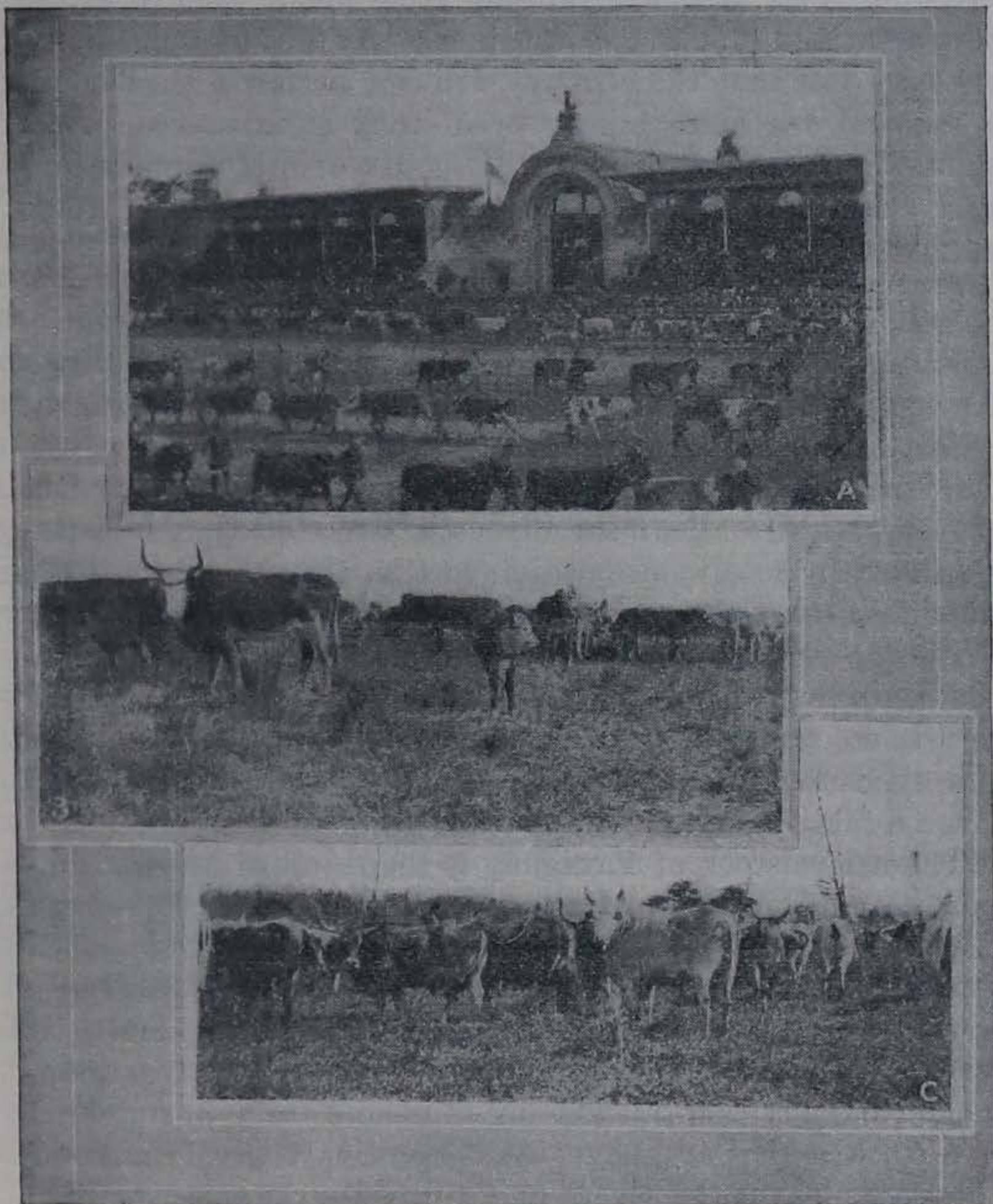

Scenes in Brazil and Argentina.

Above: Parade of prize winners at the formal opening of the Palermo exposition. This exposition is the ranking live-stock show of South America.

Middle: Half-blood Hereford cow with three-fourths blood calf, Brazil. One of the interesting features is the marking of the white face. This cow is a dun color with the exception of the face and underline, while the calf is a typical Hereford red.

Below: Native steers on fattening pastures of catingueira grass in Barretos district, Brazil. Note evidence of zebu blood in the shoulder development and the light loin. These steers were slaughtered in the week following the taking of this picture.

breeding stock at prices ranging from about \$250 to \$1,250 for cattle, and \$150 to \$500 for hogs. At first thought breeders may feel that these prices will not permit a profit; but a demand for more highly bred stock at advanced prices should be a natural result of the success of first importations and the improvement discernible from the use of these animals.

#### PARAGUAY.

Paraguay is one of the least-developed countries of South America as regards the live-stock industry. Although the climate is only fairly favorable to stock raising, one of the chief reasons why development has been slight is the fact that practically all of the domestic live stock has been assimilated by local consumption so that there has been little outside trade in live stock, meat and animal products. With the establishment of two meat-canning abattoirs at the beginning of the war, however, a new interest appeared in live-stock breeding. The demand, which exceeded the supply, caused a great inflation in prices, and those who had large establishments realized substantial profits.

The native stock of Paraguay is the result of original importations from Spain, Portugal and Peru which have been allowed to breed rather indiscriminately and without much attempt at constructive work. Little incentive to excel in a given industry or enterprise is offered the people, and it is evident that much will be required in the way of development from any country wishing to open a trade in purebred live stock with Paraguay. As Argentina controls most of the shipping on the rivers and furnishes the most feasible entrance into Paraguay, Argentina is in the best position to promote this business; consequently there is little, if any, opportunity for the United States to develop an extensive live-stock trade in Paraguay in the near future.

#### URUGUAY.

Notwithstanding the fact that Uruguay is one of the smaller Republics, the live-stock business in general has attained a very high degree of development. The improvement of the stock of Argentina and an increasing trade with Brazil furnish a stimulus for the industry in this

country and, as a result, rapid strides are being made. Breeders are attacking the pest and disease problems and there are indications that more concerted action will be taken soon.

Yearly live-stock exhibitions are held in various sections of the country, the shows at Montevideo and Salto being the most important. At these expositions the prestige of the prize winners and the blood lines they represent is among the most important and interesting features. The difference in price received at auction between a prize winner and an animal outside the awards in some cases means a difference of fully 50 per cent, so that competition is decidedly keen. Another interesting feature of the shows, particularly at Salto and the others outside of Montevideo, is the practice of sending large numbers of breeding animals for the purpose of sale. At the Salto show in 1919 there were about 5,000 head of "camp stock"; that is, grades entirely pasture-raised. These were sold at auction in lots of from 5 to 200. The breeders often buy up large numbers of females and perhaps one of the prize-winning bulls with which to restock. The interest in these sales is very marked, and stockmen who have reputations as successful breeders receive large prices for their surplus stock. The average bidding for this camp stock at Salto this year (1919) was from \$140 to \$250 for females and \$150 to \$500 for bulls. The purebreds are also sold at this time, and, as in the United States, there is a very wide variation in prices. Several prize winners sold as high as 15,000 to 20,000 pesos (\$15,400 to \$20,800, United States gold).

The exhibits of pen lots of sheep are of special interest, and often the 10 shown are the choice of 50 sent in for sale at the auction. Throughout the period of the show, the various breeders are attempting to fill their needs for the ensuing year, so that interest is easily maintained until all the stock is sold.

The swine industry is not so well established at the shows, although it is growing rapidly. The increase in general agriculture is coincident with a greater attention given to the breeding of hogs, so that the industry in Uruguay is rapidly growing away from the purely local consumption basis. There is reason to believe that this growing interest can be

centered upon the rapidly maturing hogs from the United States. At present, the most widely known breeds are the Berkshire and Yorkshire, although a few Poland Chinas may be found. The general conditions under which hogs are raised indicate that the corn-belt hog would be a success in Uruguay.

More attention is being given to dairy stock at present than has been the case in past years. The Guernsey, Holstein and Jersey are represented, although the necessity of importing and producing superior individuals has not been apparent to the breeder until recently. The practice of handling the stock entirely in pastures is similar to that in the ranching sections of the United States and is favored by a 10 to 12 months' grazing period. Because of this similarity of certain conditions, breeders should welcome efforts to introduce purebred live stock from the United States. The fact that these breeders are able to use the best of the stock raised in the United States and to pay adequate prices should make the development of this market attractive to American breeders who seek a foreign outlet for their stock.

The best-known breeds of stock, approximately in the order of their popularity as shown by imports, are Hereford, Shorthorn, Devon and Aberdeen Angus cattle; Merino, Lincoln, Romney Marsh and Hampshire sheep; and Berkshire, Yorkshire, Poland China and Duroc Jersey hogs.

There is a growing tendency on the part of breeders to visit the country of export for the purpose of purchasing breeding stock, but the greatest opportunity to develop any volume of business will be through consignments from breeders in the United States and through orders from Uruguayan buyers who have been well satisfied with former shipments. The animals which will receive the most favorable reception will be the best of the purebreds of good blood lines, preferably pasture-raised. The stock at the live-stock shows in 1919 were not highly fitted, but rather in good breeding condition. The primary interest in the minds of the breeders of Uruguay is the usefulness of the animal in question, and stock sent to this country should not be overdone in the matter of condition.



## ARGENTINA.

Shorthorns, high prices, and the English trade are, to the well-versed live-stock breeder, terms almost synonymous with the name Argentina. More information is available concerning the live-stock business of this country than of any of the other South American Republics. If the United States wishes to enter into an export business with Argentina, it is obvious that it will involve the exportation of the best class of live stock produced in the United States. For several years England has sold many of the prize winners of the Royal and other live-stock exhibitions to the Argentine trade, which accounts in many cases for the high price averages obtained.

The agricultural and live-stock interests of Argentina are fostered by the Sociedad Rural de Argentina (Argentine Rural Society), under whose direction the annual live-stock show at Palermo is held. This exposition is rated as one of the greatest live-stock exhibitions in the world and shows the largest number of well-bred Shorthorns of good type. The exposition in 1919 was considered one of the finest yet held, despite the fact that foot-and-mouth disease caused the highest mortality experienced in several years. The outbreak, which came at calving time, was so destructive that the Government is at this time (fall of 1919) considering legislation to control the slaughter of female stock. It is customary to hold auction sales after the close of the show, when most of the exhibited stock is sold. At the 1919 sales 6,686,970 Argentine pesos were paid for animals, as follows:

*Sales of animals at 1919 live-stock show at Palermo, Argentina.*

Class of animals.	Number sold.	Total amount.		Average prices.	
		Argentine pesos. <sup>1</sup>	U. S. gold equivalent.	Argentine pesos. <sup>1</sup>	U. S. gold equivalent.
Shorthorn.....	823	5,227,150	\$2,299,946	6,351	\$2,794
Hereford.....	104	452,600	199,144	4,352	1,915
Aberdeen Angus.....	88	256,050	112,666	2,909	1,280
West Highland.....	2	3,800	1,672	1,100	484
Dairy stock.....	31	76,500	33,660	2,468	1,086
Sheep.....	470	398,500	166,540	848	378
Hogs.....	180	91,745	40,368	509	224
Horses.....	97	180,150	79,266	1,857	817
Goats.....	4	475	209	.....	.....

<sup>1</sup>Argentine peso figured at \$0.44 United States gold.

The champion Shorthorn was sold at the record price of 100,000 Argentine pesos, or about \$44,000 United States gold. The champion Hereford sold for \$8,800 United States gold, the champion Aberdeen Angus for \$6,820, the champion sheep for \$3,564 United States gold, and the champion

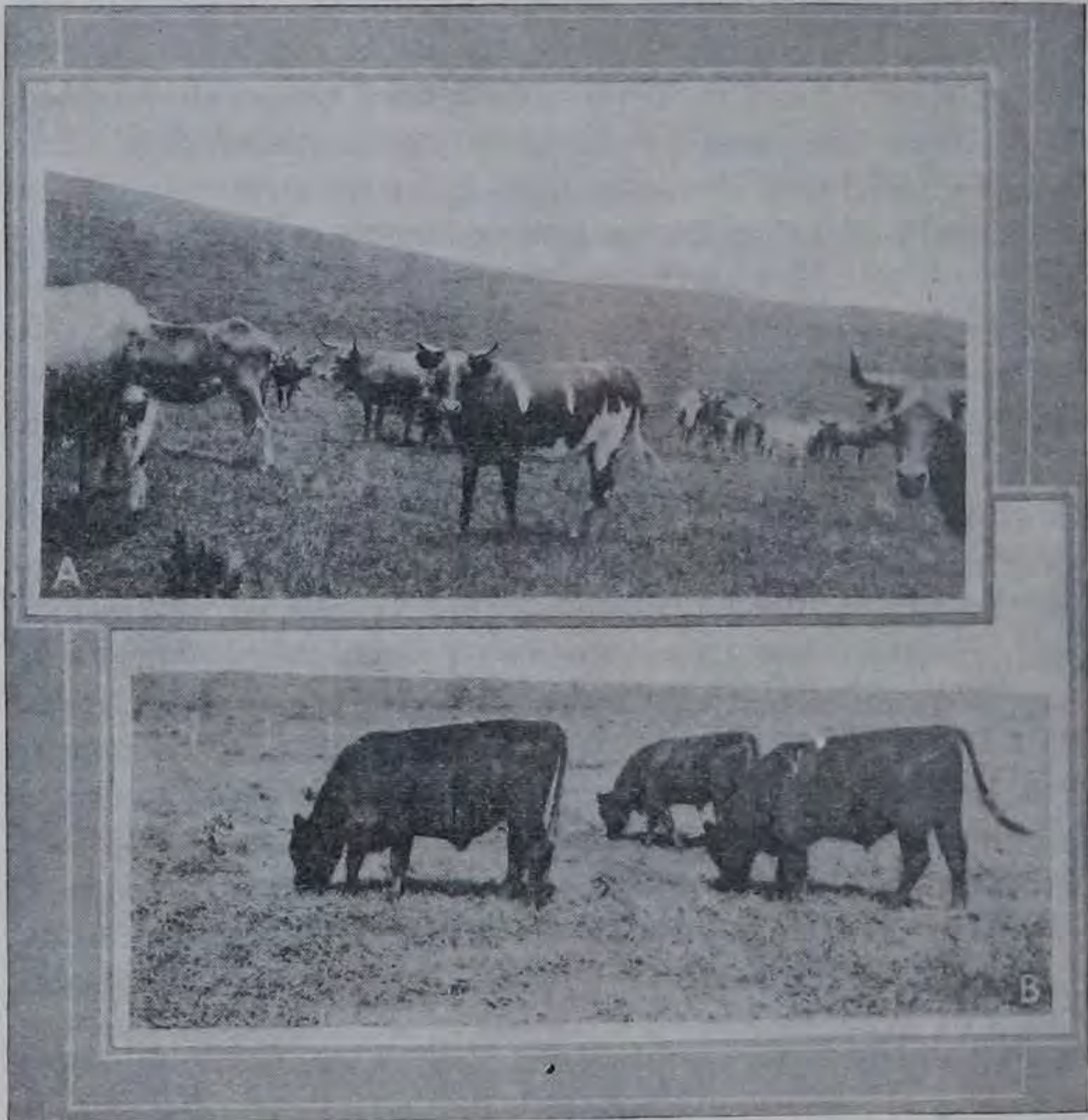

First-Cross Heifer and Group of Purebred Bulls.

Above: Halfbred Shorthorn-native heifer. Compare evident improvement of first cross with other stock in background. Note head of cow at right of picture.

Below: Purebred Shorthorn bulls bred and raised in Brazil. Note solid color, an important requirement for animals for Brazilian trade.

boar for \$2,000. A high degree of interest was evident and the large attendance at the exhibits proved the popularity of the industry.

Entries in the dairy-cattle division were not numerous, although a number of fine individuals were shown and there was a noteworthy interest among the people in the exhibits both of stock and of dairying machinery.

The exhibits of sheep evoked a large amount of interest among the breeders, and the champion animals were applauded with as much enthusiasm as were the prize cattle. The high prices received for the best stock indicate that improvement is steadily progressing in sheep as well as in cattle. Large numbers of improved Lincolns, Romney Marshes, Merinos, and Rambouillets were exhibited.

The exhibit of swine was similar to that of previous years, with Berkshires, Yorkshires, Duroc Jerseys and Poland Chinas among the entries. Special attention is being directed toward the increased production of swine in Argentina, and in 1919 the interest in these animals was said to be more marked than that manifested at any of the recent Palermo expositions. The prices received at the sale were higher than ever before, and considerable attention was aroused by the price of \$2,200 United States gold paid for the champion Berkshire sow.

The horse classes are not large at these expositions, although the specimens exhibited in 1919 were superior in type and quality. The champions of the Percheron, Clydesdale, Shire and Hackney breeds were especially good individuals, and the interest shown in this section indicated that there is an increasing tendency toward improvement in horses.

It is evident that there is in Argentina a demand for certain breeds and classes of stock which the United States is well prepared to meet. Competition for this business, however, will be very keen, and the natural preferences formed by many years of dealing with other sources of supply will have to be overcome by the superior value of the stock offered and by the results produced. Only the finest cattle of our types will sell to advantage in Argentina. The Argentine buyer also is giving more and more attention to the pedigree of the animals he uses in his herd, and a study of these specific requirements will be necessary if success is to be attained in the development of trade relations.

Although the greatest interest thus far has been in Short-horns, there is a growing demand for other breeds. The champion Hereford and Aberdeen Angus at the Palermo exposition were very high-class animals. The superior type of the animals of the breeds most in favor in the United

States should meet with equal favor among breeders of Argentina whose methods of handling cattle closely resemble those of the United States.

It is important that breeders who are considering a trade with Argentina should make an effort to establish direct connections with companies which are prepared to handle our purebred stock. There are several established auction companies at Buenos Aires, where practically all of the sales of imported stock are held. Although many of these companies have direct connections with exporting firms in other countries, several successful organizations engage only in a commission business, whereby they are prepared to sell all kinds and classes of breeding stock, both local and imported. Although direct connections are especially desirable for the permanent trade, it may be desirable in some cases to make first importations through these commission companies.

The success of breeders of the United States in the Argentine market, as in the other countries, will depend to a large degree upon the quality of the first shipments.

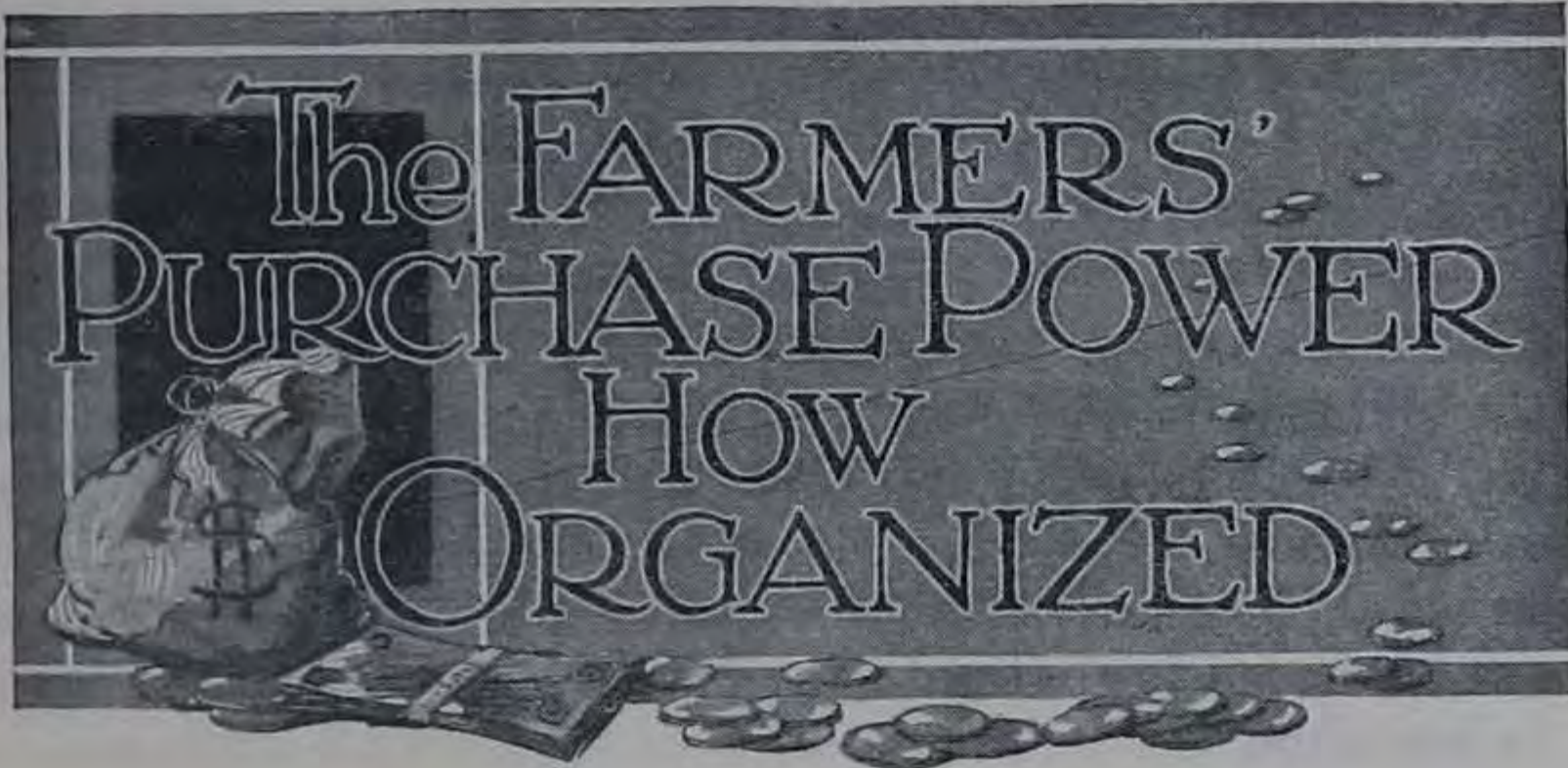
An illustration at the top of the page shows a large sack of money on the left, with several coins scattered across the floor in front of it. The background is a dark, textured surface. The title text is overlaid on this illustration.

# The FARMERS' PURCHASE POWER HOW ORGANIZED

By J. M. MEHL,

*Investigator in Cooperative Organization, Bureau of Markets.*

THE success of certain large chain stores and similar organizations is a result partly of their ability to combine many small purchases into a single body of large volume. They are able to buy in large quantities articles of merchandise which the average dealer or single-store organization must buy in small quantities at higher prices. Concentration of buying power may enable an organization of this kind to take the entire output of a manufacturer, thus eliminating the manufacturer's selling expense and effecting a reduction in cost. With these organizations such purchase power is a thing to be created or developed, usually by competitive struggle.

Every agricultural community has an already existing purchase power which when brought under control may secure to the community the same benefits and savings which the large commercial organizations derive from their concentration of buying power. It only needs to be organized. Instead of being divided into a number of small streams, each running its separate course and contributing to the support of a number of weak and inefficient agencies, it may be organized and directed into a single channel and thereby develop a considerable power for saving. This does not mean necessarily that middlemen will be eliminated, although the effect may and should be to discontinue inefficient agencies. Agencies which facilitate distribution will always

be required, and the concentration of a community's needs will serve to strengthen such agencies as are actually needed.

Much useless argument on the question of eliminating middlemen will be avoided if discussion is limited to a consideration of their proper functions. A reduction in number or a change of character is frequently confused with the elimination of functions. Certain middleman functions are the result of growth and development and may be necessary. Ownership, or control, of middleman facilities, however, is a question of expediency and certainly may not be denied to that industry or class of persons who are to be benefited.

#### POSSIBILITIES AND LIMITATIONS OF COOPERATIVE PURCHASING.

##### ELIMINATION OF UNNECESSARY SERVICE.

Various forms of cooperative activity are found in the United States, a considerable number of which are organized for the cooperative purchase of farm supplies. Feeds, fertilizers, spraying material, containers, and certain kinds of farm machinery are among the items most frequently purchased cooperatively. The largest savings are possible on this class of supplies because much of the service ordinarily required of dealers can be dispensed with. It would not always be necessary for large stocks of this class of merchandise to be carried by local dealers in anticipation of farmers' needs, if the farmers would get together and estimate their requirements in advance. The warehousing of merchandise involves expense and also encourages a credit business which entails further cost. Much saving could be effected if farmers would relieve local merchants of burdensome credits and useless warehousing and sales expense. But farmers acting individually usually will not seek to reduce cost in this way. Indeed, the average dealer hesitates to offer any special inducements to individual cash purchasers and persons who are in a position to do their own warehousing and financing, because of the dissatisfaction which it tends to create among his less progressive patrons. It is difficult for a merchant to maintain successfully one scale of prices for one class of customers and another for a different class.

It seems necessary, therefore, for those farmers who are in a position to dispense with certain kinds of service first to form an organization of some kind through which they may voice their common desires. Having organized, it will not be difficult to secure the kind and amount of service required, and if the prices of local dealers then are reasonable with reference to the service which they are called upon to perform, the organization may wisely continue to patronize such dealers. If, on the other hand, local dealers assume an antagonistic attitude and refuse to recognize that the organization is entitled to a price reduction in proportion to its concentrated volume of business and lessened amount of service required, the organization is in a position to deal directly with wholesalers, jobbers, or manufacturers. No comparison of prices on any commodity is fair to the local dealer which does not take into consideration the service which is required in its handling, and the efforts of a cooperative organization first should be directed toward determining just how much service can be dispensed with and how much speculative and merchandising risk can be assumed by the members themselves.

The organization which can do the most effective work is the one which can eliminate all unnecessary service. Persons who prefer to buy goods in small quantities, who require the local merchants to carry large stocks to supply their varying needs, and who demand the extension of long-time credit must expect to pay for such service. Unfortunately, many persons who do not require the extra service and do not benefit by it are compelled also to contribute to its support. The effect is to place a premium upon slovenly and uneconomic practices. A cooperative organization has done much if it has merely furnished the opportunity for thrift to those who would be thrifty.

#### STANDARDIZING PURCHASES.

The greater the number of kinds and brands of supplies used for the same general purpose in a community, the less will be the volume of sales of any one kind or variety. Conversely, if a large number of persons using many different brands of the same kind of supplies can determine

upon one or two, the volume of business in those brands will thereby be increased and a greater purchase power can be brought to bear in bargaining for them with dealers or manufacturers. In the average community, a wide variety of brands and kinds of supplies are used for the same purpose. Differences of opinion exist as to the merits of some kinds compared with others, but usually one or two kinds may be found which are in general use and will prove quite as satisfactory to the community as the wider variety of supplies. A cooperative organization furnishes a convenient medium through which to determine by systematic study and observation the kind of supplies or machinery which is best suited for the needs of a community. In the case of feeds, fertilizer, and spraying materials, the organization will be able to secure chemical analyses and expert opinions the cost of which would be too great for the members to assume singly. These means assure the receiving of high-grade goods.

#### SCOPE OF ACTIVITY.

A cooperative purchasing association will function best when its activities are centered in the handling of a limited variety of such supplies as are staple and of general utility in the community. The service which it performs should be of a highly specialized order, and for this reason it should avoid as far as possible handling miscellaneous merchandise or shelf goods. Except in rare instances it will not be advisable to deal in any commodity which is not bought in carload lots and distributed from the car door. Contrary to the fear sometimes expressed by local merchants, it is a far cry from the simple cooperative purchasing association to the cooperative store. It is true that cooperative stores have followed the organization of purchasing associations in some instances, but usually they have followed as a result of antagonism on the part of merchants rather than as a consequence of the purchasing association. Cooperative stores require an entirely different form of organization and method of conduct, and when a cooperative purchasing association takes on the activities of a store many of the wasteful practices which the purchasing association was intended to eliminate frequently result.



A cooperative organization should strive to be different from a privately owned enterprise. Its conduct of business should be of a kind and character which make impossible the comparison of it with any noncooperative business. Every phase of its operation which can be compared with a like phase of the operation of a private business offers an opportunity for unfriendly interests to compete and discredit. Its purpose should be not so much to eliminate the net profits of dealers as to eliminate wasteful practice and unnecessary service. When this is fully understood and made known to the local dealers there will be little ground for objection on their part. In fact, dealers who are progressive and awake to their opportunity frequently will welcome such an arrangement, because it relieves them of much expense and inconvenience which brings them no profit, but on the other hand exposes them to criticism by those not understanding nor appreciating the distinction between gross profit and net profit. An article of merchandise may be handled upon what appears to be a very great profit but which, when the expense connected with its storage and sale has been deducted, is in fact a very nominal profit.

#### FORM OF ORGANIZATION.

##### INCORPORATED ASSOCIATIONS.

The form of organization which is adopted by a cooperative association will have much to do with its success or failure. Many persons look upon a cooperative purchasing association as a rather simple undertaking, which requires little or no detailed plan of operation and therefore no permanent form of organization.

Though relatively simple when compared with certain types of marketing associations, a cooperative purchasing association, nevertheless, requires a very firm and specific structure. It is not necessary that the organization plan should be elaborate, but whatever form is decided upon, whether the incorporated capital stock or nonstock form, or the voluntary association form, it must be suitable to local conditions and the particular kind of activity which is to be conducted.

A greater number of unincorporated associations perhaps exist among cooperative purchasing associations than among any other class of cooperative business organizations. This is due in part to the fact that many persons associate an incorporated company with the capital stock form of organization, which usually is not advisable for a simple purchasing organization. Again, in a number of States, it is not possible to incorporate business organizations of the nonstock form. In these States it is necessary either to form a capital stock company with the par value of stock placed at a nominal sum or to operate as a voluntary association. No capital stock is usually required in simple purchasing associations. In fact, it may offer a temptation for improper use.

#### UNINCORPORATED BUYING CLUBS.

Cooperative associations should be incorporated whenever possible and whenever the organization proposes to engage in any business involving the credit or liability of the members through the actions of an agent or manager. Sometimes the members of a farmers' club or other semi-business and social organization wish to avail themselves of the advantage of collective buying without the formality of incorporating by simply utilizing the existing organization machinery. In every such case there should be established a method of conduct which makes it impossible for any member or officer to constitute himself an agent for the purpose of binding the body of members except in a very special and restricted sense. The necessity for this arises from the fact that generally, subject to some exceptions, an unincorporated association has practically the same status in law as that given to a partnership. In many States the individual members will be held jointly and severally liable for the acts of the managing agent. An unincorporated organization should operate, therefore, along lines which make it unnecessary to clothe the agent or manager with any but the most limited and restricted powers. He must be shorn of every power to bind members except by special appointment for a special purpose. He should have absolutely no power to pledge the personal credit of members. Moreover, the business must be so conducted as to make it plainly evident to the trading public that he has no such power.

PLAN OF OPERATION.

CAPITAL REQUIREMENTS.

A clearly defined plan of operation should be worked out in detail and be embodied in a formally adopted set of by-laws,<sup>1</sup> whether the association intends to operate as an incorporated body or merely as a voluntary association.

If warehouses or permanent buildings are deemed necessary they may be provided for by the sale of capital stock in the case of a capital stock form of organization, or by membership fees in the case of nonstock organizations or voluntary associations. In but few cases is it advisable to provide a cash working fund in this way. Each member should be required to finance himself by advancing to the association an amount in cash or credit which will cover the amount of his purchases. Unless this is done, and money belonging to the association is available for the purpose, it will soon be found that a credit business with the members has been established. The worst feature of using association funds for the purchase of supplies lies in the fact that members will grow careless in estimating their requirements and when a shipment arrives may fail to call for the goods which they have ordered, thereby throwing a loss upon the association.

The amount of capital necessary to finance buying operations should be made available by each individual member in proportion to the use of capital required by his needs. It is not meant that each member should provide a sum in cash which will be always available and which will be placed entirely beyond his control. There must be provided, however, means whereby payment of goods ordered by him can be enforced legally and simply. Before any orders are collected, each member desiring to participate in the buying operations may make arrangements with his local bank to honor any orders signed by him up to an amount previously decided upon by the association's board of directors as being adequate to cover his purchases.

---

<sup>1</sup> U. S. Department of Agriculture Bulletin 541 contains a suggested form of by-laws for cooperative associations which is capable of being adapted to various forms of organizations.

When it has been determined that a certain member's maximum capital requirement at any one time is, say, \$100, that member will immediately furnish the association's secretary with a statement from the bank certifying that it will honor and pay any orders signed by the member, not exceeding in the aggregate \$100, which may be presented to it during a specified time. Arrangements with the bank may be made either by means of a loan, bearing interest only during the time actually in use, or by having a charge made against the member's checking account, as for a certified check.

#### METHOD OF CONDUCT.

The required capital having been provided, there must be established a convenient means for applying it to the purchase of supplies. For this purpose an order form may be provided which will authorize the bank to apply the available funds to the payment of goods upon their arrival.

A simple and practical method of applying funds to the payment of goods which are ordered would seem to be an order to purchase and an order to pay combined into one instrument which is signed by each member at the time orders are being collected. When sufficient orders are collected to make up a shipment they are placed with the bank and applied by the bank in payment for the shipment upon its arrival. The responsibility and powers of the business agent or secretary of the association in his relations with third parties are thus narrowed and limited to a point where his duties will consist chiefly in collecting and placing orders, notifying the members of the arrival of shipments, and effecting delivery thereof.

The following combination order and payment form is suggested:

Order No. .... (Date) .....19....  
 To .....

Please purchase for me and have delivered to ..... station on the ..... railroad, the following supplies, which I agree to receive upon arrival. Notify me of arrival by ..... at .....

Quantity.	Description.	Estimated price.	Amount.
.....	.....	.....	.....
.....	.....	.....	.....
.....	.....	.....	.....
.....	.....	.....	.....
.....	.....	.....	.....

(Signed) ..... (Purchaser.)

To the ..... Bank, (Date) .....19....

Pay to ..... dollars (\$.....),  
 the amount of my accompanying order No. .... for supplies on arrival at ..... station but not to exceed ..... dollars.

(Signed) ..... (Purchaser.)

This order certified and payment guaranteed this ..... day of .....19....

..... BANK,  
 By ..... Cashier.

† Perforated.

This order form may be executed in duplicate or triplicate, except that the order upon the bank is signed on the original only.

In practical operation the plan here suggested will work about as follows: Orders will be assembled by the secretary of the association, or by some person appointed as purchasing agent, at prices estimated sufficiently high to cover all charges and handling costs. When a sufficient number of orders are had to make up a quantity shipment, the secretary or agent proceeds to bargain for its purchase. This may be done by advertising for sealed proposals or by a canvass of firms dealing in the supplies desired. When a satisfactory proposal has been received and accepted, all of the individual orders are placed with the bank selected to handle the funds of the association, and the bank certifies to the firm or dealer

whose bid has been accepted that the amount of the whole order is on deposit and will be paid upon arrival of the supplies in good order and up to the standard. After paying for the shipment the balance of the funds is placed by the bank to the credit of the secretary of the association or the person designated as agent, who, when delivery has been effected, computes and deducts all handling charges and his commission or salary apportionment, if upon a salary basis, and then refunds to the members the difference between the estimated cost and the actual cost of the supplies bought.

If desired the order may be executed in blanket form; that is, no estimated prices need be stated. The bank is authorized to pay the association agent the actual computed cost of the supplies specified up to and not exceeding a certain amount. When the goods have been delivered and the actual cost has been ascertained, the agent fills in the correct cost prices and net amount of order in the check form, which is then charged to the member's bank account. Thus adjustment is effected without the passing of any actual money.

#### POINTS TO REMEMBER.

The essential points in the plan here suggested are:

- (1) Elimination of all unnecessary service and warehouse expense.
- (2) Standardization of purchases.
- (3) Buying in carload lots only.
- (4) Buying only staple supplies.
- (5) Utilizing the machinery of local dealers whenever possible.
- (6) Securing the members' signed orders in advance of purchase.
- (7) Ordering no supplies for any member unless the order is accompanied by cash or its payment is guaranteed by a local bank.

# LIVE STOCK DROUGHT RELIEF WORK IN 1919



By GEORGE M. ROMMEL,

*Chief, Animal Husbandry Division, Bureau of Animal Industry.*

**D**URING the spring, summer, and fall of 1919 the northwestern part of the United States suffered for the third succeeding year from extremely dry weather. The rain and irrigation water was not sufficient for the usual crop growth in that area or to provide adequate supplies of water for live stock. Each year had seen an increasing number of live stock shipped out, and the severity of the drought in 1919 caused stockmen to become alarmed. Through their representatives in Congress they appealed to the Department of Agriculture for assistance. With the benefit of the department's experience, gained through work in Texas in 1917 and 1918, in moving live stock from the drought area to feed and pasture elsewhere, Acting Secretary Clarence Ousley, in July, appointed the committee on live stock drought relief to take charge of the coordination and administration of the work. This committee consisted of L. D. Hall, Chief of the Division of Live Stock and Meats of the Bureau of Markets; C. B. Smith, Chief of the Office of Extension Work, North and West, of the States Relations Service, and the writer as chairman.

Mr. Ousley's instructions to this committee on July 10, 1919, were as follows:

(1) Bureau of Animal Industry to direct movement of cattle, in cooperation with Bureau of Markets, particularly officers of that bureau at central markets.

(2) Bureau of Animal Industry to determine locations into which cattle may be sent where grazing conditions permit.

(3) Bureau of Markets to handle the shipment of feed into Montana, as heretofore.

(4) Organization: Bureau of Animal Industry force (details being given of tentative assignments from this bureau).

In transmitting these instructions to the three bureaus concerned, Mr. Ousley expressed the understanding that some of the details of the last two paragraphs might require amendment. This was done later, and these two paragraphs read as follows:

(3) Bureau of Markets to handle shipment of feed into Montana in cooperation with Bureau of Animal Industry and States Relations Service.

(4) Organization: Administrative and field forces of the Bureaus of Animal Industry and Markets, and the States Relations Service.

#### THE DEPARTMENT ACTS PROMPTLY.

The three bureaus represented on the committee on live stock drought relief were officially charged with the administration of this work. A fourth bureau, the Forest Service, although not specifically represented on the committee, rendered invaluable assistance, first, by a rapid survey of the stock on the National Forests, and later by giving advance information of the run to be expected out of the forests to market.

This committee had full charge of the work from the beginning and reported directly to the Secretary of Agriculture. No funds were available for the relief work except as regular appropriations could be drawn upon. In view of the urgent character of the emergency, available balances under established projects were drawn upon in the expectation that Congress would later relieve the appropriations to the extent of the amount actually spent over and above normal expenses, not counting the time of regular employees detailed from their usual duties.

The department and others had already conferred with the United States Railroad Administration for the purpose of establishing emergency rates on feed into the drought area and on live stock to be shipped out for feeding and grazing and later returned. The people of Montana had shown commendable energy in attacking the problem and



had sent a representative of the Agricultural Extension Division to Minnesota to determine the availability and extent of feed and grazing lands in that State. This plea for assistance was met with a State-wide campaign in Minne-

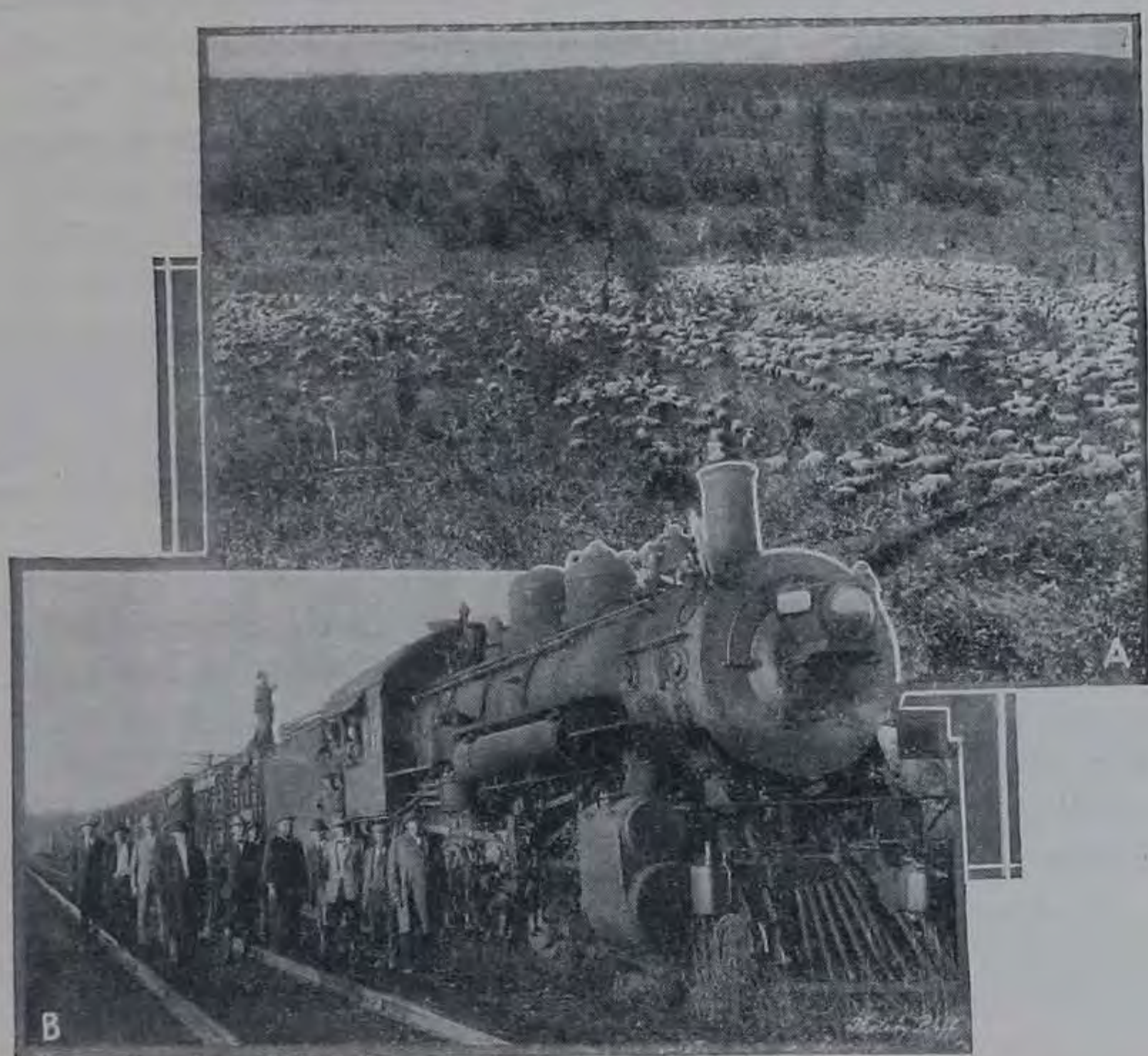

A. Shipment of Sheep Going on Range in Lake County, Minn.

B. Trainload of 4,100 Sheep Arriving at Two Harbors, Lake County, Minn., from the Drought Area of the Northwest.

sota to locate pasture land and hay. Within a very short time much accurate information was available, and a considerable number of sheep had already been moved into Minnesota and adjacent States.

#### PLAN OF ORGANIZATION.

In order to coordinate and systematize plans for the work the department, through the committee on live stock drought relief, called a conference of interested persons to meet at St. Paul on July 15. This conference was attended by 200

persons from all sections of the North and West, representing every agency likely to be in a position to assist in the movement.

At the close of the conference the plans which had been worked out for the organization were announced, and work was immediately begun. An emergency office for the East was established at the Union Stock Yards, South St. Paul, Minn., with headquarters in the local offices of the Bureau of Markets. Prompt measures were taken to locate persons having available grazing land and hay land which could be harvested by crews from the West, as well as supplies of hay for sale. A field force traveled among the feeding sections in the adjacent territory, determined as far as possible the best outlets for live stock from the Northwest, and acted as intermediaries between the extension divisions of the agricultural colleges and the county agents in the different States and the market forces at the stockyards. An emergency office to keep in close touch with the situation in the drought area was established at Billings, Mont. This office devoted especial attention to Montana, North Dakota, South Dakota, and Wyoming. Conditions in Idaho, Utah, and Colorado needing relief were met mainly by the live-stock extension forces of those States.

Special letters were issued by the South St. Paul office at frequent intervals giving information concerning the shipments of cattle and sheep from the Northwest to market, market quotations, lists of available pasture lands, probable demand for stock for feeding purposes, etc. Statements of the location and amount of pasture, hay, and feeding stuffs available were sent to the western office and made public in such manner that no injustice was done to any one and no untoward influence brought to bear on the market.

#### FIELD FORCE ACTS PROMPTLY.

Approximately 4,000,000 acres of grazing and hay land, with sufficient information to determine its value for cattle and sheep, were listed within a very few days. Requests from farmers in the stock-feeding sections for information pertaining to the purchase of more than 3,000 cars of cattle and sheep were received. Many purchases were made di-

rectly from owners in the West who were anxious to sell, but the bulk of the purchases were made from stock shipped to central markets.

Lists of live stock for sale were assembled by the western office and sent to prospective purchasers in the East. Those who wished to purchase hay or other feed or locate grazing



Ewes that Were Brought in from the Northwest in July  
Being Shipped to Market in October.

The lambs from this shipment brought a record price on the St. Paul market.

lands were put in touch with those having them, and forces in all other sections kept reliably informed as to conditions in the area affected.

Throughout the entire summer and fall the offices in both the East and West were flooded with inquiries as to conditions and possible relief measures which should be taken. No doubt it was the encouragement, counsel, and advice of the forces engaged in the work that overcame pessimism, encouraged people in the West, and at the same time possibly prevented unscrupulous persons from taking advantage of the drought sufferers.

Later in the summer the drought relief committee established emergency offices at Chicago, Omaha, and Kansas City. The service from these offices was similar to that from the St. Paul office, mainly to keep prospective purchasers of feeder cattle and sheep in adjacent territory informed as to movements of live stock from the drought area, together with prices and demand on the markets, and to keep in touch with supplies of feed available for shipment to the Northwest and of pasture lands available for lease. A mobile field force was available at all the offices and traveled throughout the territory adjacent to them, gathering information.

The Railroad Administration established special emergency rates. These rates provided for one-half the regular rates on feeds shipped into the drought area, with the exception of cottonseed meal and cake, on which a rate of 60 cents per 100 pounds was established to Montana and 50 cents per 100 pounds to Wyoming. Cattle shipped out to be fed en route and marketed later received the same feeding-in-transit privileges which formerly applied to sheep, and on live stock shipped out to be returned rates equivalent to one and one-third for the round-trip rate were allowed, or a reduction of two-thirds on the return shipment. The rates on feed are available until April 1, 1920, and the return rate on live stock until June 1, 1920.

#### OUTSTANDING FEATURES OF THE DROUGHT.

The writer was thoroughly familiar with the conditions during the three years' drought in Texas and had been through Montana in May, 1919. He left St. Paul immediately after the conference for a more careful study of the situation in the Northwest, while others remained in the East to organize more completely measures of relief in that area.

The most encouraging feature in the West was the contrast between the condition of Montana live stock and that of Texas during the drought. Practically no animals were seen which were not in good condition; even cows suckling calves were strong and in moderate flesh. In fact, it is safe to say that until the approach of winter there was practi-

cally no starvation on the northwestern ranges. The reasons for this are found, first, in the remarkable feeding value of the native grasses in the Northwest, and, secondly, in the fact that the turf had not been destroyed by overgrazing

A. One Type of Range Pasture Used by Cattle and Sheep.  
Michigan Upper Peninsula Experiment Station.



B. Same Area after Sheep Had Grazed on it All Summer.  
Michigan Upper Peninsula Experiment Station.

or lack of rainfall. In Texas during the height of the drought one could drive over miles of territory on which no more grass was visible than on a ballroom floor. Nothing of this kind was seen in the Northwest, except along a few mountain sides, which probably never had been heavily carpeted with grass.

The area of the drought included approximately the northern half of Colorado and most of Utah and Nevada, from which territory it increased in intensity northward, becoming severe in the northern half of Idaho and of Wyoming, and embracing all the State of Montana, extending into the northwestern part of South Dakota, and the western half of North Dakota, and into Alberta and southwestern Saskatchewan. (See map.) Although the drought had been more prolonged in Montana (practically three years

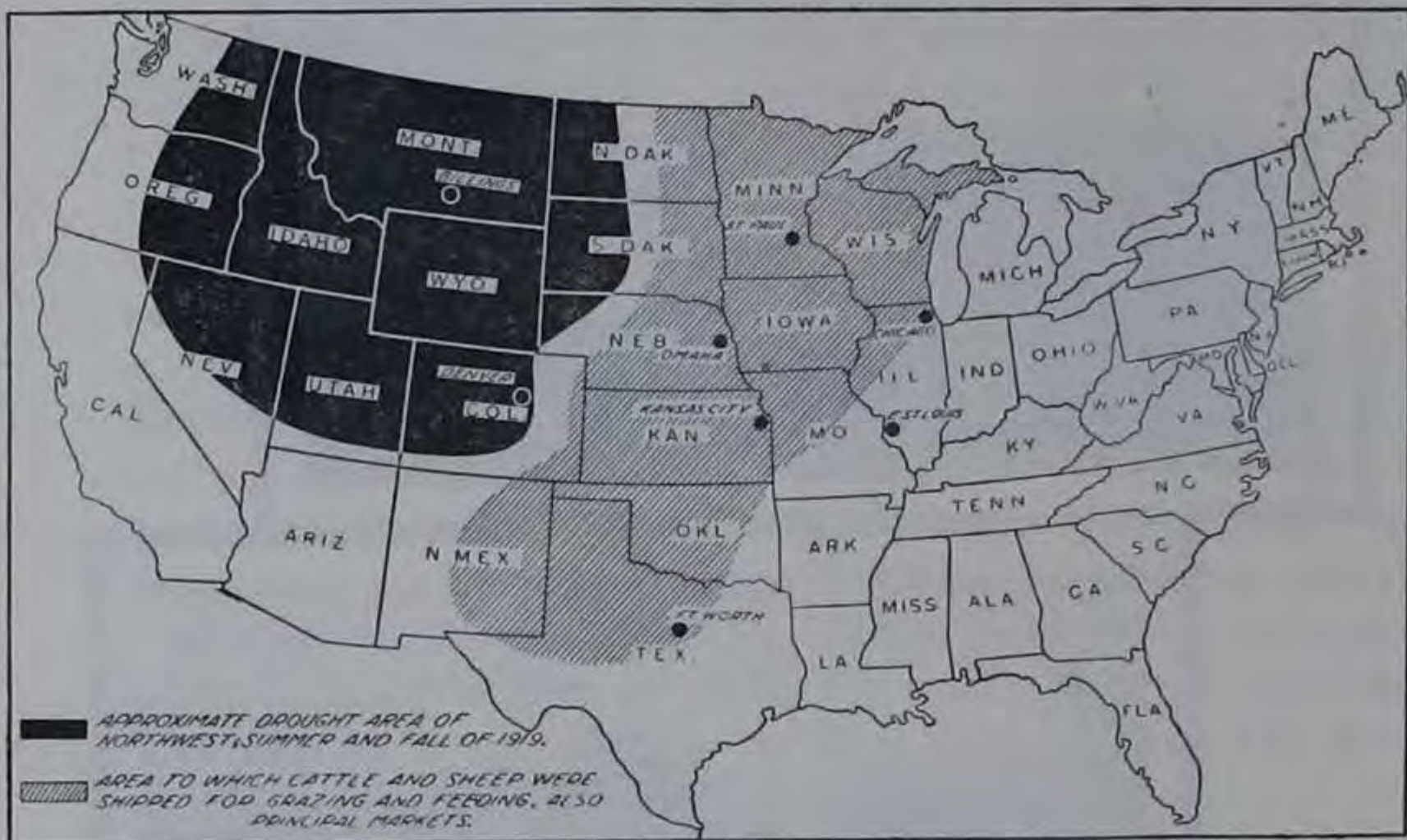

of crop failure having been experienced by dry farmers), the most intense drought of 1919 was in the northern half or two-thirds of Wyoming, where practically no rain fell from early spring until late fall. As usually happens in such disastrous climatic visitations, what western people call "spotted" rains occurred—local showers which kept grass more or less green and gave certain localities better range than others. The southeastern corner of Wyoming never became so dry as the north-central portion, and the extreme northwestern corner of North Dakota had good grass throughout the season. Even parts of Montana received rainfall enough to give a certain amount of winter feed with careful ranch management. Extremely high temperatures in the summer months and high winds almost every

day accentuated conditions and accelerated evaporation. For example, Havre, Mont., had 1.99 inches of rain in June, but it also had average temperatures far above normal, with constant winds.

The most serious problems confronting ranchmen were not so much an immediate shortage of grass as the danger of springs and streams drying up and the approach of winter, which set in much earlier than usual and in some sections was quite severe. It was therefore necessary to reduce herds to the minimum, to conserve available feed supplies, and to ship in surplus feed from elsewhere. The department advised ranchmen to take account of available feed supplies and if at all possible to hold cows and ewes with young at side, sending steers, wethers, and lambs to market as soon as ready, and young or half-fat stock to pastures elsewhere.

#### SPIRIT OF THE WEST.

At the time this movement began, in July, decided signs of panic were evident throughout the drought region. In a month's time, however, they had entirely disappeared. No doubt the effort which was being made to avert calamity was having its effect. People in the affected territory had got their second wind, so to speak, and were determined to see the situation through to a successful finish. The spirit of the West was manifesting itself and people were facing the outcome with courage and fortitude. The large prospective crops of corn and hay in the Middle West and the discounting of hay shortage in the Northwest itself had much to do with the revival of confidence. As time went on, attempts at profiteering in hay proved abortive, and many speculators who had bought considerable quantities of hay intending to profit by their neighbors' distress found the shoe on the other foot and were anxious and eager to sell hay contracts by the middle of September.

#### THE AREAS OF RELIEF.

The first effort of Montana ranchmen was naturally to seek pastures near by. Pastures in South Dakota and Nebraska were therefore filled up early. Two unique features

of the relief work were found in the movement to Minnesota, Wisconsin, and the Upper Peninsula of Michigan, and to Texas and New Mexico. Most of the northwestern ranch-

A. Cattle on Native Pasture in Marquette County, Mich.



B. Watering Place in the Cut-Over Area.



C. Cattle Grazing on the Cut-Over Range in Upper Peninsula of Michigan.

men were inclined to feel that the movement of cattle from what is locally called "hard grass" to the more succulent pastures of the central portion of the country would likely



prove to be unsatisfactory. This opinion prevailed notwithstanding the fact that sheep and cattle had been sent into the Great Lakes regions during the past few years for grazing purposes. Actual developments show, however, that both cattle and sheep were moved into Minnesota, Wisconsin, and the Upper Peninsula of Michigan in large numbers with generally satisfactory results. Some reports of dissatisfaction with conditions in this territory have been received, but these can be attributed in practically every instance to the fact that the animals were thin when moved in and sold later in only feeder condition on a declining market, that they were moved too late (October in some instances) for the available feed to be of fullest benefit to them, or that the ranges were poorly selected and not well suited to the purpose. The drought relief committee has a much larger number of reports and letters from ranchmen expressing satisfaction with the range in that territory than it has reports of criticism. While movement into that area necessitates a long winter feeding season, the abundant forage available during the growing season as well as the excellent water supply has proved attractive to many.

The view was emphasized by every one that western stock should not be moved into the Great Lakes region until the owners had personally inspected the tracts offered and satisfied themselves as to their suitability for grazing purposes. The owners of the land made extremely attractive offers, in some cases offering it without charge for summer and fall pasture. The movement of Texas cattle into the Southeast in 1917 and 1918 gave a decided impetus to the development of the live-stock industry in that area, and it is safe to say that a similar impetus has been given the already growing industry in northern Minnesota, Wisconsin, and Michigan. Many of those who, through necessity, came into this area in 1919 doubtless will return with other shipments of stock as time goes on.

Wyoming and Montana have been accustomed for nearly half a century to receive from the Southwest annual inflows of cattle for grazing, but it was a new suggestion to them to consider a reverse movement. The return of Texas and New Mexico to good grazing conditions has been one of the most phenomenal occurrences in our agricultural his-

tory. From a condition of extreme depletion of pastures, Texas returned in less than a year's time to better pasture conditions than ever had been known before, with cattle in

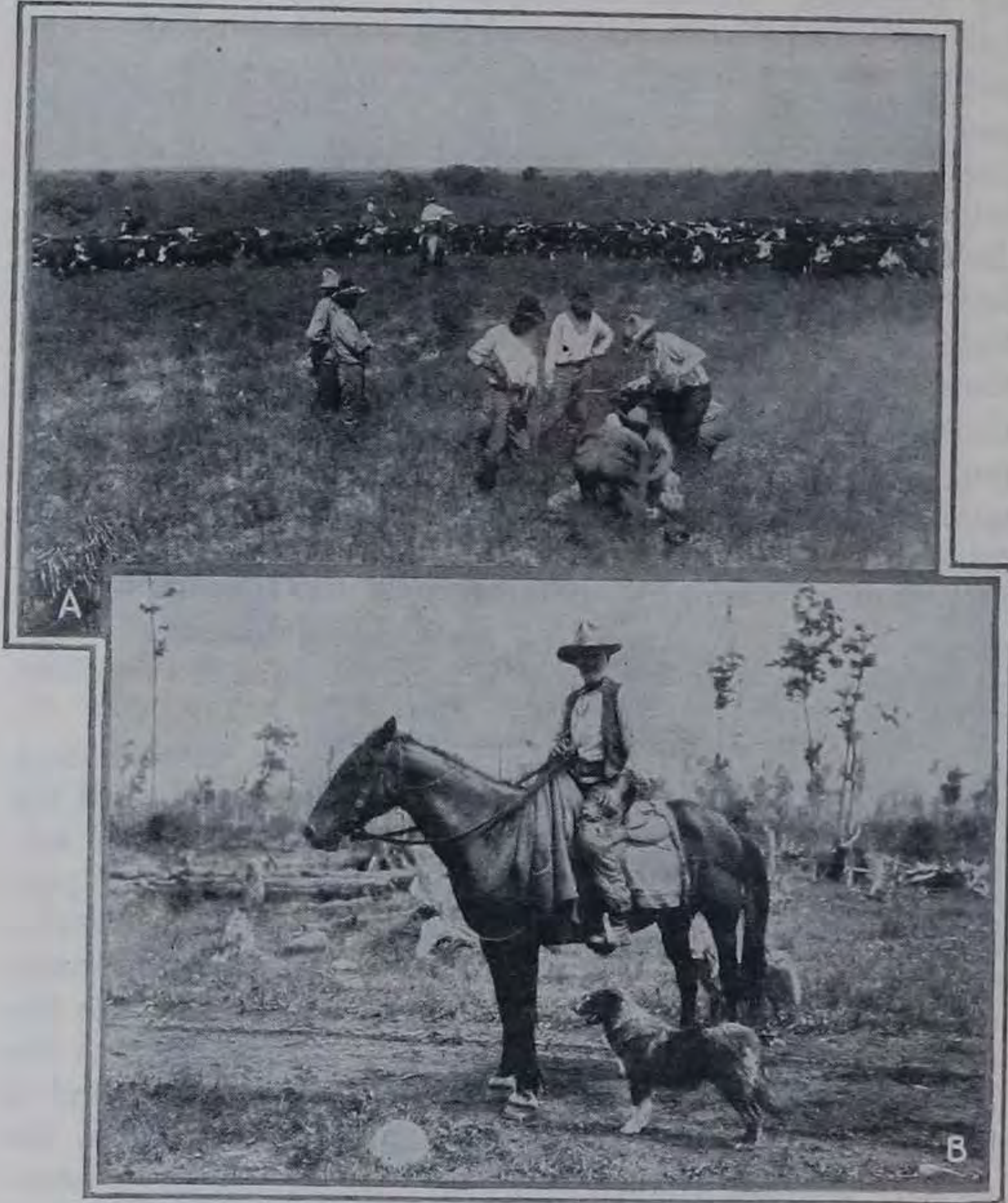

A. A Ranch Scene in Texas.

Large numbers of cattle and sheep were shipped for pasture. The picture was taken in the fall of 1919 and shows the remarkable transformation which the Southwest has had after a year of ample rainfall.

B. Sheep Herder Who Had Just Arrived from the Northwest.

better summer condition and range more abundant. The liquidation of cattle from Texas and New Mexico pastures in 1917 and 1918 made it impossible to find this year sufficient surplus stock at hand to consume the abundance of

forage available. Eventually this outlet, with its milder winters and the consequent saving of winter feed, proved attractive, and many northwestern ranchmen took advantage of it, entire herds in some instances being moved. The movement was still under way in mid-November.

It should also be mentioned that the demand for feeder sheep by the Central Western farmers, especially in the Missouri Valley, absorbed hundreds of thousands of the thin lambs which reached the Missouri River markets during the height of the run. Some of these sheep were grazed on aftermath, some of them were used to salvage lodged grain, and some of them were used in the usual feeding operations of that section.

#### ACTUAL RESULTS.

Normally the movement of cattle out of Montana is between 200,000 and 300,000 head each year. In 1919 it is estimated that between 500,000 and 600,000 head were shipped out for all purposes, which represents a supernormal movement of at least 200,000 head. Available figures are not at hand from which to make a similar comparison in the case of sheep. As nearly as it is possible to estimate from reports of representatives in the field, somewhere between 400,000 and 500,000 head of all classes of stock were moved out of the Northwest into sections east and south of the drought area for feed and grazing purposes through the cooperative effort of all forces under the department's leadership. In addition to this, ranchmen and farmers in the drought area have been saved large sums by purchasing feed supplies in quantity, by the material reduction in freight rates on feed shipped in and live stock shipped out, and by the prevention of high prices for feed on account of the careful surveys of local feed supplies which were made by the agricultural extension forces.

#### LESSONS FROM THE RELIEF WORK.

The writer considers that lessons of great importance were brought out in the drought relief work of 1919. The first is the service which can be performed by public agencies working in cooperation. A striking illustration of the Government's ability to perform a useful service was given to the

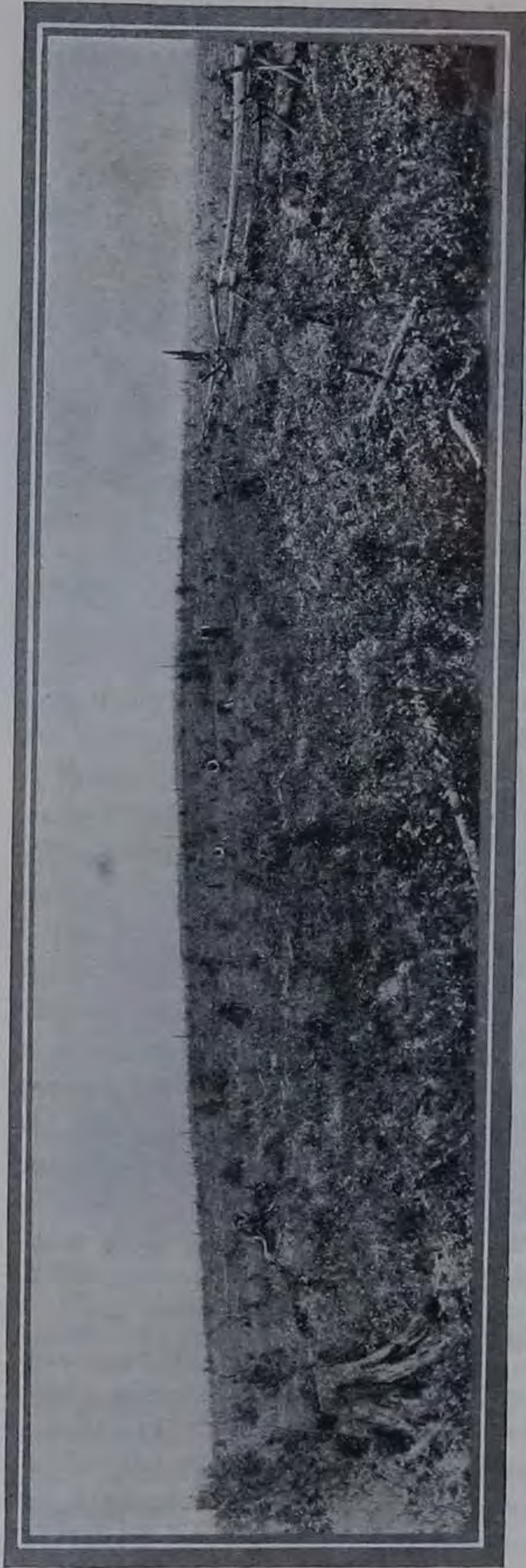

Type of Cut-Over Range in Minnesota that Afforded Excellent Pasture for Live Stock.

people of the Middle West and the Northwest, and it was demonstrated to them that the cooperation of distinct and separately administered branches of the Government is by no means an impossibility.

Four separate branches of the United States Department of Agriculture, several regional offices, as well as the headquarters of the United States Railroad Administration, the Federal reserve banks, and the Federal farm loan banks, with their governing boards in Washington, a score of agricultural colleges, as many more State agencies of various kinds, hundreds of county agents, and a host of semipublic and private institutions, business men, bankers, ranchmen, farmers, and representatives of the press worked together during the

summer and fall of 1919 to move cattle and sheep out of the drought area of the Northwest to feed and pasture elsewhere and thus averted the national calamity which would certainly have followed their premature slaughter or their starvation on the ranges during a severe winter.

Men of every Government, State, and other agency, and, particularly, the county agents in the different States took loyal part in this work. Self-seeking was exceptional. It was the rule for every man to regard the work at hand as of more importance than the individual. Inter-bureau lines, inter-departmental lines, and State lines disappeared in the prosecution of this task.

The second great lesson is that, with proper organization and the dissemination of accurate information, a drought, even so severe as that which plagued the Northwest for so long a period, need not have a calamitous outcome. The United States covers such a wide range of latitude and longitude, and has such a diversity of topography, climate, and rainfall, that drought never covers the entire country with equal intensity at one time. It is reasonably safe to assume that a shortage of feed in one section will always be counterbalanced by an abundance in some other section. To point out these possibilities and to direct the machinery whereby they may be utilized are proper functions of the Federal Department of Agriculture, and to take advantage of them is the opportunity of those who may be affected by unfavorable weather conditions.

# LIVE STOCK CONDITIONS

## *in* EUROPE



By TURNER WRIGHT, *Investigator in Marketing Live Stock and Meats, Bureau of Markets*, and GEORGE A. BELL, *Senior Animal Husbandman, Bureau of Animal Industry*.

[Based on observations made during 1919.]

INASMUCH as the European demand for American live stock and live-stock products is a factor which must be considered in all our live-stock operations during the period of readjustment, the condition of the live-stock population of Europe is a subject of vital importance to American stock growers.

The general impression which prevailed in this country during the period of the war was that European flocks and herds would of necessity be depleted by the ravages of the conflict and by the demands for meat to supply the needs of both the fighting forces and the civilian population of the warring countries. This belief, with the prevailing high prices compared with those of other years, tended to stimulate production in this country even before the United States entered the struggle. The campaign for increased production during 1917 and 1918 brought about a still greater increase, with the result that at the time of the signing of the armistice the numbers of cattle, hogs, and sheep in this country were materially greater than in 1914, at the beginning of the war.

It was generally considered that there would be a reasonably good demand among the European countries for whatever surplus might exist in this country at the conclusion of hostilities. Developments since the signing of the armistice, however, have indicated that the live stock of Europe has been preserved to a much greater extent than had been anticipated. There was a decrease in the total number of horses, cattle, sheep, and swine in the 10 countries of western Europe, and prices were considerably higher than in pre-

war times. Farmers generally had taken advantage of the high prices to cull their flocks and herds closely, selling all old and inferior animals and retaining the best young ones.

#### LIVE-STOCK CONDITIONS IN FRANCE.

Statistics of the ministry of agriculture in France show that the decrease in the number of horses from 1913 to 1917 was nearly one million head, or about 30 per cent, but the shortage was somewhat alleviated by the 2,300,000 cattle



Normandy Cow on Farm Near Caen, France.

April, 1919.

which were classed as work animals in 1918. More than one-half of these work cattle were cows.

The number of Percherons was greatly reduced during the war, but successful efforts were made to retain a good supply of high-class breeding animals with which to rehabilitate the studs. The Percheron breeders are looking forward to a resumption of export trade in breeding animals. The high prices prevailing for both work stock and breed-

ing animals will probably restrict the exportations to small numbers for the present.

There was a decrease of  $1\frac{3}{4}$  per cent in the number of cattle from December, 1914, to June, 1917, followed by an increase of 7 per cent from June, 1917, to June, 1918, and the general opinion in France during the early part of the summer of 1919 seemed to be that this rate of increase had continued to June, 1919. If this opinion was correct, the total shortage of cattle in France in June, 1919, as compared with December, 1913, was only approximately 540 thousand.



Normandy Bull on Farm Near Cherbourg, France.

April, 1919.

The number of cattle decreased  $14\frac{1}{2}$  per cent from December, 1913, to December, 1914; the number of sheep in France was decreasing even before the war, and during the five years of war the number fell from about 16 million to  $9\frac{1}{2}$  million. There was a decline in the slaughter of sheep at the Paris live-stock market, the largest in France, in both 1918 and 1919, which seems to show a tendency on the part of farmers to conserve breeding stock, notwithstanding the high prices for meat which have prevailed. The relatively great reduction in the number of swine from 1913 to



1918 was no doubt due in a large measure to a shortage of concentrated feed. There also is little doubt that with favorable conditions with respect to feed and a continuation of existing high prices the herds of swine could be replenished very rapidly.

The shortage of cattle and concentrated feed brought about a shortage in milk, butter, and cheese. Condensed milk was imported during the war to supplement local production, most of which was used for the Army. The civilian consumption of condensed and evaporated milk seems to have increased.

There is no meat-packing industry in France, such as has been developed in the United States. It was stated that American cured sides and salt pork, as a rule, do not meet the French taste. American hams and best grades of bacon, however, seem to meet with approval, but these products are too expensive for the average French family. The people of France have not been accustomed to eating frozen meat, although the Government in 1919 was trying to encourage the use of frozen meat in order to reduce the price of meats to the consumer and to conserve the French breeding stock. All kinds of live stock were relatively high priced. Good young cows in Normandy were worth from 1,500 to 2,500 francs (\$290 to \$483), which was practically three or four times as much as similar cows brought before the war.

There appeared to be plenty of forage and practically all of the stock seemed to be in very good condition. Grass was abundant, and the general opinion was that there would be plenty of roughage to meet all requirements during the winter of 1919-20. The greatest handicap with respect to feed was the shortage of concentrates suitable for swine feeding, but it was expected that this condition would improve with the harvesting of the growing crops.

The fact that French farmers were culling their herds closely was evidenced by the quality of cattle seen on the market at La Villette in Paris, the leading stock market of France, as compared with the quality of the cattle seen in the breeding herds on farms in various parts of the country. Inferior young animals and older ones were seen on the market, while on the farms there were large numbers of

yearlings and 2-year-old heifers which for the most part were well grown, of good size, and in good condition. It should be noted, however, that the Government regulations with respect to weights at which cattle could be slaughtered, which were in effect until March, 1919, had a tendency to force the marketing of the older cattle, but there is no doubt that the best of the mature animals were retained while the poorer stock was sent to market.

One of the effects of the war seems to be a stimulation of interest in purebred cattle breeding. The breeders of Normandy cattle in northwestern France appeared to be taking advantage of the opportunity to advance their interests, while the societies interested in the breeding of Charolais cattle in central France have amalgamated with a view to pushing the interests of the breed. A letter received from France in November gives the information that cattlemen in Brazil have been interested in the Charolais cattle.

#### LIVE-STOCK CONDITIONS IN BELGIUM.

The live-stock situation in Belgium, while serious, is not so bad as one might have expected after four years of occupation by a hostile army. There has undoubtedly been a great reduction in all classes of live stock, but both farmers and Government officials seem optimistic as to the future. Statistics of the ministry of agriculture show a decrease of slightly more than 51 per cent in the number of cattle, a decrease of more than 77 per cent in the number of swine, and a decrease of approximately 36½ per cent in the number of horses in the country from 1913 to 1919. The ministry of agriculture estimated that 560,468 cattle, 250,215 swine, and 91,124 horses were taken out of the country by the German Government. It was expected, however, that some of this stock would be returned.

The shortage of horses in Belgium, like the shortage of horses in France, has been somewhat alleviated by the increase in the number of cattle used for work purposes. While large numbers of the high-class Belgian draft-horse stock were captured by the enemy, the breeders were fortunate in retaining many of their best horses, as was evidenced by the excellent exhibit of over 700 animals at the show of the Belgian Draft Horse Society held at Brussels in June, 1919, and by the many high-class animals seen in various

parts of Belgium. The sheep and goat industry of Belgium is of relatively small importance.

The best information available indicated that Belgium would have to depend on outside sources for quantities of frozen and cured meats to the extent of 2,000 tons a month. Cold-storage facilities accommodating about 8,000 tons of meat were being provided at Antwerp in the summer of 1919. It was estimated also that from 1,000 to 2,000 tons of



First Prize Group of Mares, Belgian Horse Show.  
Brussels, June, 1919.

condensed milk a month from outside sources would be necessary to meet the needs of the country during the winter of 1919-20.

Good milk cows sold in Belgium during the summer of 1919 for 2,000 to 3,000 francs each, which at that time was equivalent to approximately \$310 to \$460. Cows similar in quality could have been purchased before the war for 600 to 700 francs (\$116 to \$135). The live stock seen in Belgium, as a rule, was in very good condition. A severe drought during the spring and early summer, however, caused a shortage of feeds, which tended to limit the number of animals which could be carried through the winter of 1919-20.

## LIVE-STOCK SITUATION IN SWITZERLAND.

There was a general shortage of all kinds of live stock, meats, and dairy products in Switzerland in May, 1919, with the exception of sheep and goats, which had increased in number since the beginning of the war. There are only a few sheep in that country; the figures show an increase of 39.7 per cent for sheep and an increase of 4.3 per cent for goats from 1911 to 1918. The census figures for 1918 give the number of milk goats at approximately 250,000, or more than two-thirds the total number of goats. In general there appeared to be a shortage of good horses in the country, but as the Swiss farmers work a large number of cattle the shortage of horses did not seem to be giving them much concern.

The census figures of the ministry of agriculture show an increase of approximately 12 per cent in the number of cattle from 1911 to 1916 followed by a decrease of about 5 $\frac{1}{4}$  per cent from 1916 to 1918. It was estimated that there had been a further decrease in the number of grown cattle, but the figures for 1919 were not available. While Switzerland had more cattle in the summer of 1919 than in 1911, this can not necessarily be taken to mean that the country was in a better condition from the standpoint of meat and dairy production, for the increase was in the number of young stock which was not producing milk nor old enough to market for meat to the best advantage. Furthermore the feed situation had been critical because it had been practically impossible to obtain oil cakes and because the Government required that a greater amount of land be plowed and planted to potatoes and other crops than in normal times. The cattle, consequently, were thinner in flesh and the milk production had been greatly reduced.

A member of the department of agriculture of Switzerland stated that the estimated production of milk per cow had decreased almost 30 per cent by the summer of 1919. As the season had been backward, the grass both for feed and for hay did not make the growth usually made in normal years, and the cattle, as a rule, were not in such good condition as those in France. From a cheese-exporting country before the war, Switzerland had become a cheese-importing country.

Switzerland, before the war, imported several thousand cattle from other European countries every year for slaughter. This supply has been cut off through the shortage of cattle in those countries from which she was accustomed to draw supplies. It was stated that Switzerland had to supply France with 25,000 cattle, mostly milk cows, during 1919, in connection with an economic agreement. Good milk cows were worth the equivalent of \$500 to \$800, which was three or four times their value before the war.

While the decrease in swine was not serious, inasmuch as the swine population can be restored in a comparatively short time, it does mean that during the restoration period an increased amount of pork and pork products must be imported while the live hogs are being held back to replenish the herds. Before the war several thousand hogs, largely from Italy, were imported annually for slaughter.

There has been a serious shortage of all kinds of meat in Switzerland. Government officials feared that conditions during the winter of 1919-20 would be even worse unless greater quantities of meat were obtained from outside sources. A comparison of the numbers of stock slaughtered at the 19 largest slaughtering places in March and April, 1918, and March and April, 1919, shows a decrease of 36.1 per cent in the number of cattle, 16.7 per cent in the number of calves, and 25.6 per cent in the number of swine slaughtered. It was estimated that the needs of the current year from outside sources would be about 10,000 tons of frozen meat.

The interest in purebred live stock, as in France, has been stimulated by the abnormal demands brought about by the war. Farmers are taking advantage of the high prices of meat to dispose of their inferior animals and replace them with better bred stock.

#### LIVE-STOCK SITUATION IN ITALY.

The general condition with respect to live stock is much more serious in Italy than in France. The numbers of live stock were reduced very materially during the war by the needs of the fighting forces and the civilian population and by the ravages of the enemy. The best data available show a decrease of 13 per cent in the number of cattle and buffalo

in the country from 1914 to 1918; this percentage does not represent the total decrease in the production of meat and dairy products, for the decrease in grown cattle was greater than the decrease in young cattle. The numbers were still further reduced during the latter part of 1918 and during 1919, to May, the time these observations were made, by a very serious outbreak of the foot-and-mouth disease. A Government official estimated that at least 40 per cent of the cattle left in the country at the time the 1918 census was taken had died from the disease and that the total damage

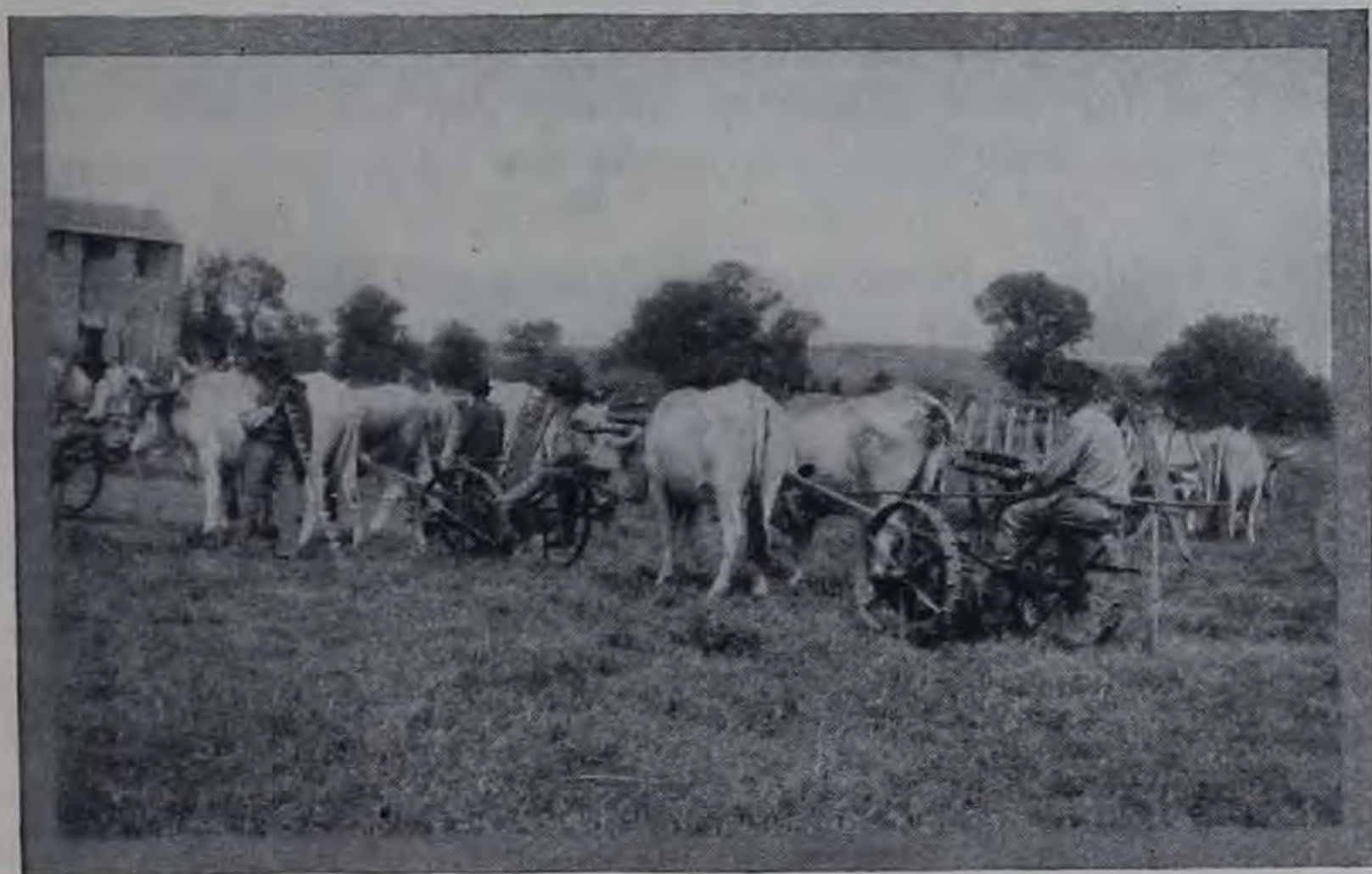

Cattle at Work in Southern Italy.

May, 1919.

to production was even greater, because of the reduction in milk yields and in flesh. If this estimate was correct, it will take many years under the most favorable conditions to bring the herds back to prewar strength.

The increase in the number of sheep and goats from 1914 to 1918 was a little more than a million, or about 7 per cent, and is partially accounted for by an increase in grass lands, due to a reduction in the amount of land devoted to the production of cereals, and by the smaller amount of labor required in growing sheep and goats. It was stated that there had been some reduction since the 1918 census was taken, because of the prevalence of the foot-and-mouth disease, but the losses had not been so great as with cattle.

The number of hogs showed a decrease from 1914 to 1918 of approximately 385,000, or about 14 per cent. It was stated that this number had been still further reduced through the ravages of the foot-and-mouth disease, but data as to the approximate loss were not available. It was noted, however, that in spite of the decrease in the hog population, hogs were being sent into Switzerland for slaughter.

Estimates for equine stock show a decrease from 1914 to 1918 of approximately 180,000, or about 8 per cent. As in Switzerland, the shortage of horses and mules did not seem to cause very great inconvenience, as large numbers of cattle are used for work purposes. There did not appear to be many good draft horses in either the cities or the country districts.

The reduction in the herds of cattle had brought about a serious shortage of milk. Condensed milk was being imported to supplement the local production. Butter and cheese were relatively scarce and very little of either was being exported. Meats of all kinds were scarce, the maximum number of cattle, including veal, which the Government allowed to be slaughtered being only 50,000 a month. The number of cattle slaughtered in Italy decreased from 1,800,000 in 1915, to 1,460,000 in 1918. At the same time the importation of frozen meat, coming largely from the United States, increased five times. The problem of obtaining adequate supplies of meat seemed to be causing much concern. The chief difficulties in obtaining meat from outside sources were the rate of exchange prevailing, the difficulty of obtaining shipping space, and the lack of cold-storage facilities in Italy. It was estimated that the needs of the country for meat from outside sources during the remainder of 1919 would approximate 20,000 tons a month.

#### LIVE-STOCK CONDITIONS IN THE NETHERLANDS.

The live-stock industry in the Netherlands seemed to be in a very prosperous condition at the time these observations were made, in June, 1919. All classes of live stock were in good condition, and there appeared to be sufficient grass to meet all requirements. The large numbers of cattle seen in the pastures and fields were in striking con-

trast to the depleted herds in parts of France, Italy, and in Belgium. Data compiled by the ministry of agriculture for the Netherlands showed a decrease of slightly more than 6 per cent in the number of cattle, a decrease of approximately 48 per cent in the number of sheep, a decrease of 67 per cent in the number of swine, and an increase of 8 per cent in the number of horses from June, 1913, to March, 1919.

The decrease in hogs was said to have been due mainly to the shortage of grain feeds and oil cakes, which formerly had been purchased from America. The production of milk, butter, and cheese likewise had been reduced because of inability to obtain feeds which formerly were imported. In normal times 50 per cent of the dairy products were exported, but the production in June, 1919, was sufficient only to meet normal consumption. It was thought, however, that with the importation of feeds the country would soon be in a position to make exportations of butter and cheese. Inasmuch as the production of swine is closely associated with the dairy industry, it seemed probable that the condition with respect to swine would also improve.

It was stated with reference to meat that local production probably would be sufficient to supply the immediate needs of the country. Considerable quantities of pork products, however, must be imported while the herds of swine are being reestablished. It appeared that small amounts of frozen meats might be imported to prevent prices to consumers from advancing.

Heifers and cows offered for sale on the Rotterdam market June 24, 1919, sold for from 300 gulden (\$121) for the heifers to 1,000 gulden (\$402) for the best cows. Government officials and representatives of the live-stock industry stated there had been a marked increase in the registration of purebred animals, particularly cattle, during the war. This increase in registration was attributed to the belief that there would be a large foreign demand for purebred cattle from the Netherlands after the war. Some breeding cattle had been sold to go to Belgium and to France and inquiries had been received from Brazil. A comparison of the breeding stock seen on farms around Rotterdam, The Hague, and Amsterdam with cattle offered for sale for slaughter on the



Rotterdam market showed that farmers were taking advantage of the high prices for meat to cull their herds closely, retaining only the best for breeding purposes and in many instances replacing grade with purebred animals.

#### LIVE-STOCK CONDITIONS IN THE UNITED KINGDOM.

The condition of the live-stock industry in general in the United Kingdom seemed to be satisfactory in the summer of 1919 to the Government officials and to others directly interested. The numbers of animals in the herds and flocks



Cattle at the Hull Live Stock Market.

July, 1919.

had been maintained much better than was anticipated, considering conditions prevailing during the war. It was conceded generally, however, that the average weight of animals in the various classes had decreased as compared with the average weight of prewar times. This decrease in weight was due to the shortage of concentrated feeds, to the large percentage of young animals, and to drought conditions which prevailed in England during the early summer of 1919.

Data collected by the British board of agriculture and fisheries, for the years 1914 and 1918, show an increase during the war of approximately  $3\frac{1}{2}$  per cent in the number of

horses, an increase of slightly more than 1 per cent in the number of cattle, a decrease of slightly more than 3 per cent in the number of sheep, and a decrease of approximately 29 per cent in the number of swine. It was estimated that the increase in cattle occurred in the number of cows and heifers kept for milk and the number of other cattle under 2 years old. Many cattle seen in both England and Scotland were comparatively thin in flesh, and the cattle shipped from Ireland to the London market could have carried more flesh. The consensus of opinion seemed to be that while the total number of cattle had increased, the average weight had decreased about a hundredweight (112 pounds).

The decrease in sheep was attributed by some to the plowing of pasture lands, and by others to a decrease in the consumption of mutton by the English people. Statistics show that the number of sheep in the United Kingdom had been decreasing for several years before the war. The general opinion seemed to be that there would be no material increase in the number of sheep with the return of normal conditions.

The decrease in the number of swine was caused very largely by the scarcity of grain feeds. The number of swine produced in the United Kingdom, however, has always been comparatively small, consequently the reduction during the war did not seem to be causing great concern. As the breeding stock has been fairly well maintained, the swine population can be increased very rapidly when favorable feed conditions develop.

One of the results of the war was a great shortage of milk in the United Kingdom. The milk situation seemed to be improving by the middle of the summer of 1919, but it was the general opinion that considerable quantities of condensed milk would have to be imported during the winter of 1919-20. Approximately 290,000,000 pounds of condensed and evaporated milk were imported by the United Kingdom in 1918, largely from the United States. The manufacture of butter substitutes in Great Britain increased greatly during the war.

While Great Britain probably consumes a larger amount of frozen meat than any other country in the world, there appeared to be considerable prejudice against the use of

the frozen product. The Government price regulations for the winter of 1919-20 gave a differential of 3 pence per pound in favor of native beef as compared with imported frozen beef.

Complaints were made that British consumers did not like American bacon imported during the war. Fresh-pork products, however, such as loins, met with much favor. It was stated on several occasions that there would be a fairly good demand for fresh-pork carcasses weighing from 125 to 150 pounds if carcasses of such weights could be supplied from the United States. Inasmuch as the people were accustomed to eating less meat during the war, the rate of



Cattle on the London Markets.

July, 1919.

consumption was not expected to go back to a prewar level even when all restrictions and regulations were removed. It appeared, however, that Great Britain would have to import considerable quantities of pork and pork products for several years to meet the needs of the country, and that these importations would have to come largely from the United States, the only available source of supply.

The purebred live-stock business in Great Britain was stimulated greatly by the war. Farmers found that the high prices enabled them, in many instances, to dispose of their grade stock and to replace it with purebred stock of

greater breeding value, with only a small additional outlay of money. The anticipation of trade with foreign countries also served as a stimulus to the purebred industry. It was found that British breeders also were looking to Brazil and other South American countries for foreign trade. Considering that they were held soon after four years of war, the displays of stock made at both the Royal Agricultural Show at Cardiff and the Highland Agricultural Show at Edinburgh were very creditable.

#### TABULAR SURVEY.

In order to obtain as much information as possible concerning the general conditions of the live-stock industry with reference to total supplies, the best data obtainable for several other countries have been collected and assembled in the accompanying tables, together with the data for those countries in which conditions have been discussed in detail. A comparison of the figures given in these tables shows that the total number of cattle in 15 countries increased approximately 9 millions, while the total number of sheep and swine (these figures are for 14 countries, as recent data on sheep in Belgium and swine in Argentina are not available) decreased approximately  $2\frac{3}{4}$  millions and  $7\frac{1}{4}$  millions, respectively. The decrease in the number of horses in the 10 countries of Western Europe was 867,000, while the increase in the other 4 countries was 1,835,000, making a net increase in the 14 countries of 968,000 head, or 2.6 per cent.

This comparison does not take into consideration the former Empires of Austria-Hungary and Russia, nor the Balkan States, other than Greece, for the reason that data regarding the number of animals in those countries are not available. If data were available for those countries a still further decrease, as compared with prewar numbers of live stock in Europe, probably would be shown.

The most important factor to be considered is that the total number of cattle, sheep, and swine in the 10 European countries for which data have been obtained had decreased, while an increase had taken place in other countries, particularly the United States, Canada, and Argentina.

The policy of the European countries probably will be to import meats and meat products to supply their needs while

the herds and flocks are being reestablished. There is no doubt that Europe will need a large amount of meat and meat products from outside sources until the shortage in live stock resulting from the war has been made good. It does not follow, necessarily, however, that importations equivalent to the shortage of meat and meat products resulting from the decrease in live stock will be made while the numbers of live stock are being brought back to a prewar basis. The inability to buy, the difficulty of obtaining credits, and the fluctuating rate of exchange are factors which will tend to limit the amount of food to be purchased from outside sources and will tend to stimulate production at home.

*Live stock in 15 countries important to international meat trade.*

Country.	Cattle.			Swine.			Sheep.		
	Before war.	After war.	Per cent change.	Before war.	After war.	Per cent change.	Before war.	After war.	Per cent change.
United Kingdom.....	12,185,000	12,311,000	+ 1.0	3,953,000	2,809,000	-28.9	27,964,000	27,063,000	- 3.2
France.....	14,807,000	13,315,000	-10.0	7,048,000	4,021,000	-42.9	16,213,000	9,496,000	-41.4
Italy.....	6,646,000	6,186,000	- 6.9	2,722,000	2,337,000	-14.9	11,163,000	11,752,000	+ 5.3
Switzerland.....	1,443,000	1,530,000	+ 6.0	570,000	364,000	-36.1	161,000	225,000	+39.7
Belgium.....	1,849,000	899,000	-51.4	1,412,000	318,000	-77.5	(185,000)	.....	.....
Netherlands.....	2,097,000	1,969,000	- 6.1	1,350,000	450,000	-66.7	842,000	437,000	-48.1
Denmark.....	2,463,000	2,142,000	-13.0	2,497,000	583,000	-76.7	515,006	247,000	-50.1
Sweden.....	2,721,000	2,584,000	- 5.0	968,000	634,000	-34.4	988,000	1,409,000	+42.6
Germany.....	20,994,000	17,227,000	-17.9	25,659,000	10,080,000	-60.6	5,521,000	5,299,000	- 4.0
Norway.....	1,146,000	1,054,000	- 8.0	228,000	225,000	- 1.3	1,327,000	1,216,000	- 8.4
10 countries of Western Europe.....	66,351,000	59,217,000	-10.8	46,407,000	21,821,000	-53.0	<sup>1</sup> 64,694,000	57,144,000	-11.7
Decrease in numbers.....	7,134,000		.....	24,586,000		.....	7,549,000		.....
United States.....	56,592,000	67,866,000	+19.9	58,933,000	75,587,000	+28.3	49,719,000	49,863,000	+ 0.3
Canada.....	6,533,000	10,051,000	+53.8	3,610,000	4,290,000	+18.8	2,175,000	3,053,000	+40.4
Argentina.....	25,867,000	27,050,000	+ 4.6	(2,901,000)	.....	.....	43,225,000	44,850,000	+ 3.8
Australia.....	11,745,000	11,040,000	- 6.0	1,026,000	1,169,000	+13.9	92,047,000	91,676,000	- 0.4
New Zealand.....	2,020,000	2,888,000	+43.0	349,000	258,000	-26.1	23,996,000	26,538,000	+10.6
5 surplus countries.....	102,757,000	118,895,000	+15.7	63,918,000	81,304,000	+27.2	211,162,000	215,980,000	+ 2.3
Increase in numbers.....	16,138,000		.....	<sup>2</sup> 17,386,000		.....	4,718,000		.....
15 countries.....	169,108,000	178,112,000	+ 5.3	110,325,000	103,125,000	- 6.5	<sup>3</sup> 275,856,000	273,124,000	- 1.0
Gain or loss.....	+9,004,000		.....	-7,200,000		.....	-2,731,000		.....

19 countries.

<sup>2</sup> 4 countries.

<sup>3</sup> 14 countries.

*Live-Stock Conditions in Europe.*

*Horses in 14 countries.*

Country.	Before war.	After war.	Percent- age change.
Belgium.....	267,000	170,000	-36.3
Denmark.....	567,000	511,000	- 9.9
France.....	3,231,000	2,283,000	-29.3
Germany.....	3,227,000	3,378,000	+ 4.7
Italy.....	956,000	803,000	-16.0
Norway.....	182,000	221,000	+21.4
Netherlands.....	334,000	362,000	+ 8.4
Sweden.....	596,000	715,000	+20.0
Switzerland.....	144,000	129,000	-10.4
United Kingdom.....	1,851,000	1,916,000	+ 3.5
10 countries of western Europe.....	11,355,000	10,488,000	- 7.6
Decrease in numbers.....	867,000		.....
Australia.....	2,166,000	2,441,000	+12.7
Canada.....	2,596,000	3,609,000	+39.0
New Zealand.....	404,000	379,000	- 6.2
United States.....	20,962,000	21,534,000	+ 2.7
4 other countries.....	26,128,000	27,963,000	+ 7.0
Increase in numbers.....	1,835,000		.....
14 countries.....	37,483,000	38,451,000	+ 2.6
Gain.....	968,000		.....

# SECURING A DRY CELLAR

By GEORGE M. WARREN,

*Hydraulic Engineer, Bureau of Public Roads.*

"IS THE CELLAR DRY?" is one of the first questions people ask when considering the purchase of a home. Real estate dealers say that a good cellar adds \$500 to the selling price of an average dwelling. Be that as it may, a good, dry cellar is a valuable asset, nor can its true value be measured in dollars. Rather, its value is determined by the convenience, comfort, and health of those who dwell in the home.

It is well known that dry air is a poor conductor of heat or cold and it promotes evaporation, which is a cooling process. It is well known also that moisture favors decay, corrosion, and the growth of many forms of life which are objectionable or harmful to man. For these reasons a dry cellar is better insulated and is less subject to outside temperature changes than a damp cellar. In brief, a damp cellar is unfavorable for the storage of fruits, vegetables, and foods, is destructive of sills, floors, pipes, tools, and utilities, is productive of unsanitary conditions, and without much doubt aggravates or is a contributory cause of certain well-known ailments of man.

## NEW SITES.

As it is better to avoid mistakes than to correct the consequences, it is fitting at the outset to speak briefly regarding selection of new building sites. The most important points to be observed are as follows:

(1) The site should be moderately elevated so that a fall in at least one direction from the building is obtained. Many prefer a "perched" site because of commanding view, better



movement of air, greater depth to ground water (that is, the surface of the water showing in a well or pit and often called the water table), and superior surface and underground drainage. Others prefer to forego some of these advantages and to select a site sheltered from strong winds, especially those likely to bring stormy or cold weather.

(2) The ground should be so open and porous that air and water are admitted readily, as for example sands, gravels, or soils capable of good cultivation. The vegeta-

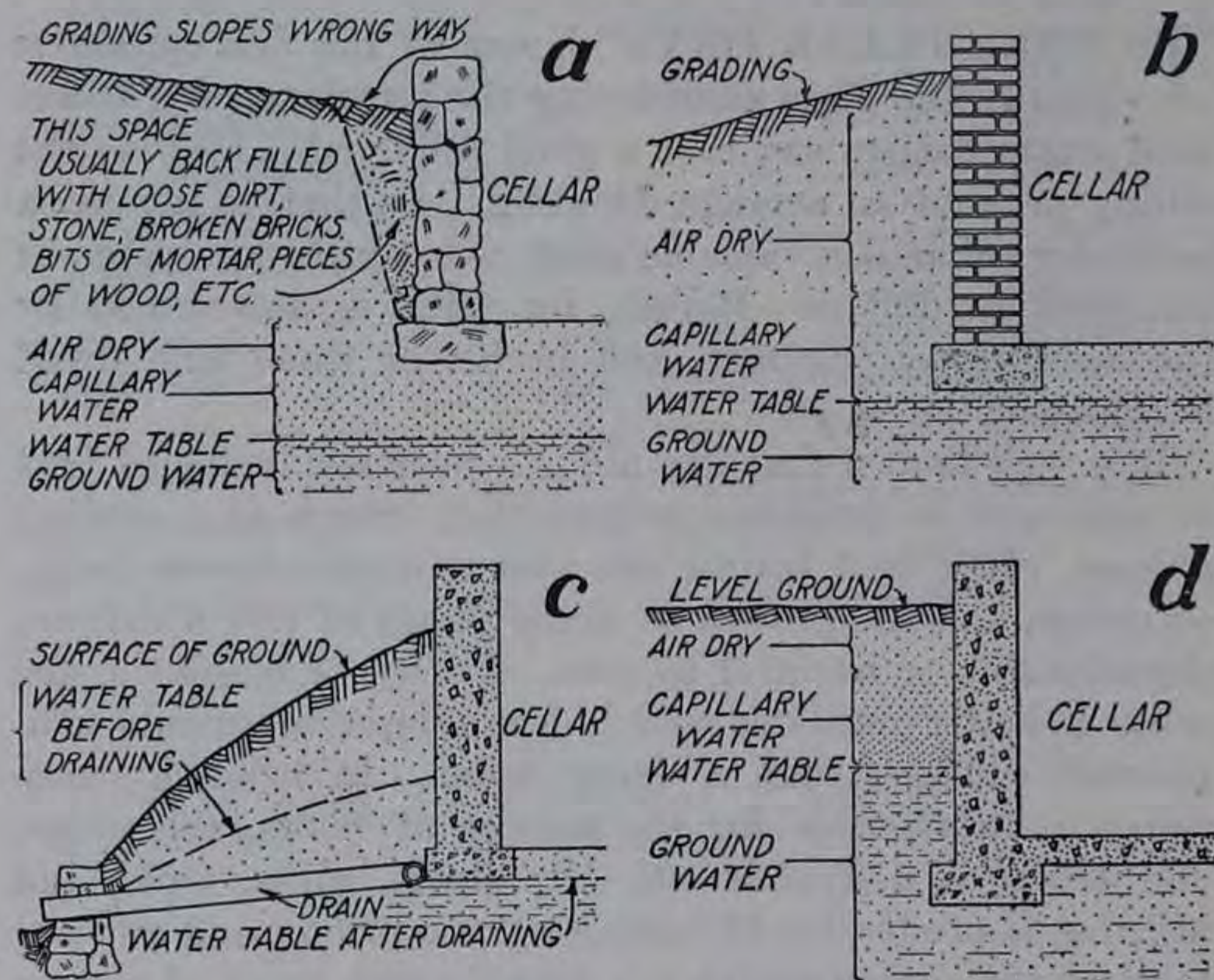

FIG. 1.—Four Classes of Ground and Ground Water Conditions.

These diagrams comprehend the causes underlying nearly all damp and wet cellars.

tion should not be profuse, and the soil and subsoil should be clean, that is, contain little or no organic wastes of either animal or vegetable origin.

(3) The site should be well and deeply drained. During the wet season of the year the ground water should be at least 10 feet below the surface of the ground, and a depth of 15 feet insures still better aeration and ventilation of the ground. As to the distance between the cellar bottom and the ground water, much depends on the character of the in-

tervening earth and the type of floor used. In precisely the same way that oil rises in a lamp wick or ink spreads over blotting paper, water will pass through the minute spaces or pores existing in all kinds of soil and many varieties of solid rock. This capillary rise in coarse sands and gravels may be no more than 2 or 3 feet, but in very fine sands, silts, and clays it may range from 5 to 8 feet.

(4) No site should be chosen without first determining the source of the domestic water supply, its purity and abundance, and fixing upon the location of a suitable plot of ground in which to waste sewage or other foul drainage.



FIG. 2.—Unsatisfactory Cellar Wall.

Sectional view of an 18-inch rubble masonry cellar wall built in Westchester County, N. Y., November, 1919. Note the joint work, the overhanging face, and the loose character of the backing where the mason stands. The site slopes sharply towards the face against which the mason is standing. In excavating for the cellar, the earth was cut down approximately to the slope A-B. As the masonry progressed, loose earth was thrown in for backing and to serve as a footing or platform for the mason. Obviously, much unused stone and bits of mortar found their way into the backing, the whole forming an excellent medium for the passage of surface water and seepage to and through the cellar wall.

#### DAMP AND WET CELLARS.

##### STUDYING THE CAUSES.

The causes of damp and wet cellars group naturally into four classes represented diagrammatically in figure 1.

(a) Where the cellar bottom is above the capillary reach of the ground water, but, because of faulty walls, backing, or grading, eaves water, melting snow, or other surface drainage passes into the cellar. (See figs. 1 (a), and 2 and 3.)

(b) Where the cellar bottom or walls are within reach of capillary water, producing merely a damp cellar.

(c) Where the cellar bottom is below the water table, but the ground slopes so that the water table may be lowered by drainage.

(d) Where the cellar bottom is below the water table and a drainage outlet can not be secured.

APPLYING THE REMEDIES.

(a) Where a cellar, by reason of poor construction and grading, becomes a sump or basin for the periodic collection



FIG. 3.—Inside Face of Wall Shown in Fig. 2.

Walls of this character abound in nearly every stone-producing locality. If the joints on both faces are well pointed and if the pointing is kept in thorough repair, such walls may be fairly secure against rats and mice. Against the searching power of water under pressure, even a small pool of surface water or a little seepage, they are of slight avail.

of water from eaves, down spouts, snow banks, or other surface sources, a number of simple remedies are employed. A surprisingly effective method, and one that improves the appearance of every low-set building, is to place additional filling against and near the cellar wall and grade down to a smooth sharp slope that shall extend at least 8 or 10 feet

from the wall. After seeding with a good lawn grass and raking, the surface should be rolled or otherwise firmed. Since the object sought is the quick shedding of surface water, steepness of the grading is very important. If necessary to grade as high as the cellar windows, a curved or rectangular well or hatchway of concrete or brick should be built about them. Hinged covers for closing the hatches during heavy rain or snow should be provided. Handled in

the manner described, the beneficial effects of a sharply-sloping, well-sodded zone around a building are surprising.

Another method frequently used is to lay a sloping pavement, walk, or gutter 2 or 3 feet in width and composed of

FIG. 4.—Shedding Water from Cellar Walls.

A sloping pavement of Portland cement concrete is useful for shedding water from foundation walls and forms a convenient walk. *A*, Well-tamped cinders (not ashes), slag, coarse sand, gravel, or stone foundation thoroughly wet just before placing concrete. *B*, Pavement; for two-course work proportion the concrete 1:2½:5 or 1:3:5; use sufficient water so that under moderate tamping it shall just flush to the surface; lay a base course 4 to 4½ inches thick; follow within 15 minutes with a one-half to three-fourths inch coat of 1:2 cement mortar worked to a smooth hard finish with steel trowels.

For one-course work prepare the foundation as above; proportion the concrete as rich as 1:2:4; lay a course 4 to 4½ inches thick; with steel trowels, promptly work the surface to produce a hard nonabsorbent finish. *C*, Wall surface abutting the pavement to be cleaned, brushed, roughened with a stone hammer and, just before placing the concrete, thoroughly wet and well smeared with neat cement paste. *D*, Cove or fillet of cement mortar.

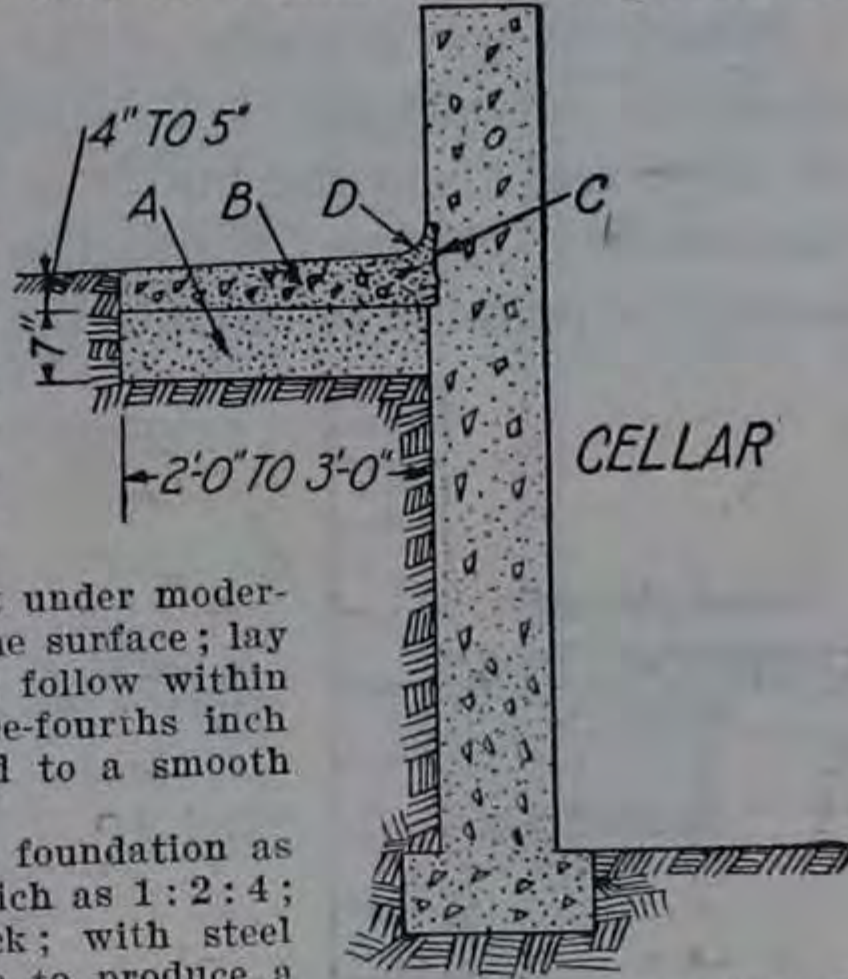
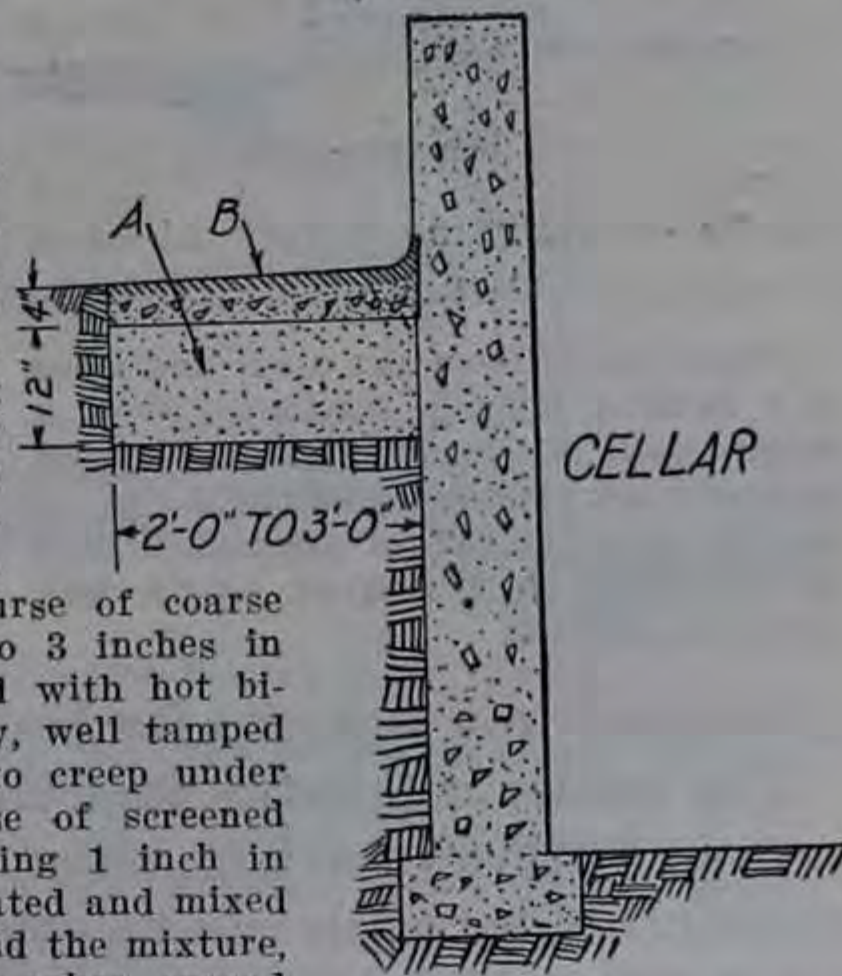

FIG. 5.—Shedding Water from Cellar Walls.

A sloping pavement of bituminous concrete for shedding water from foundation walls. *A*, Twelve-inch foundation of materials similar to those specified in fig. 4. *B*, Four-inch pavement of bituminous (best quality gas-works coal-tar refined of light oils and other matters affected by atmospheric influences is specified frequently) concrete put down in three courses; first, a base course of coarse gravel, broken stone, or slag 1½ to 3 inches in greatest diameter, partially covered with hot bituminous composition, spread evenly, well tamped and rolled until the stone ceases to creep under the roller; second, a binder course of screened gravel or broken stone not exceeding 1 inch in diameter, heated and thoroughly coated and mixed with hot bituminous composition, and the mixture, while still warm and workable with rakes, spread evenly over the base course, and compressed and rolled into the base, filling the voids and producing a smooth surface and a total depth in the two courses of not less than 3 inches; third, a wearing course or surfacing of clean sand or stone dust graded from very fine to about one-fourth inch in diameter, heated no more than necessary to make it work easily when mixed with bituminous composition, and the mixture while still hot spread in a 1-inch layer on the binder course and thoroughly compressed, followed by a sprinkling of fine sand or hydraulic cement well rolled in.



Portland cement, coal-tar, or other bituminous concrete. Such protection is illustrated in figures 4, 5, and 6, the gutter in the latter figure being useful for conducting surface water along a cellar wall.

Where no use is made of the rain water, it is always desirable to connect the down spouts with dry wells located 15 or more feet from the building or to pipe to a suitable surface outlet. Figure 7 shows the use of a dry well. In many cases it is possible to obviate the difficulty even more simply.

Figure 8 shows the well-graded grounds at a New York house, but unfortunately after heavy rains water worked into the cellar. The trouble was readily traced to one of the down spouts, which curiously was on the lower side of the house where the slope away was excellent. (Rear right-hand corner.)

The trouble was removed entirely by laying a small half-round concrete gutter about 6 feet long, as shown in figures 9 and 10. The same end often is secured by laying on the surface of the ground a U-shaped trough or gutter of wood, brick, or stone, a piece of

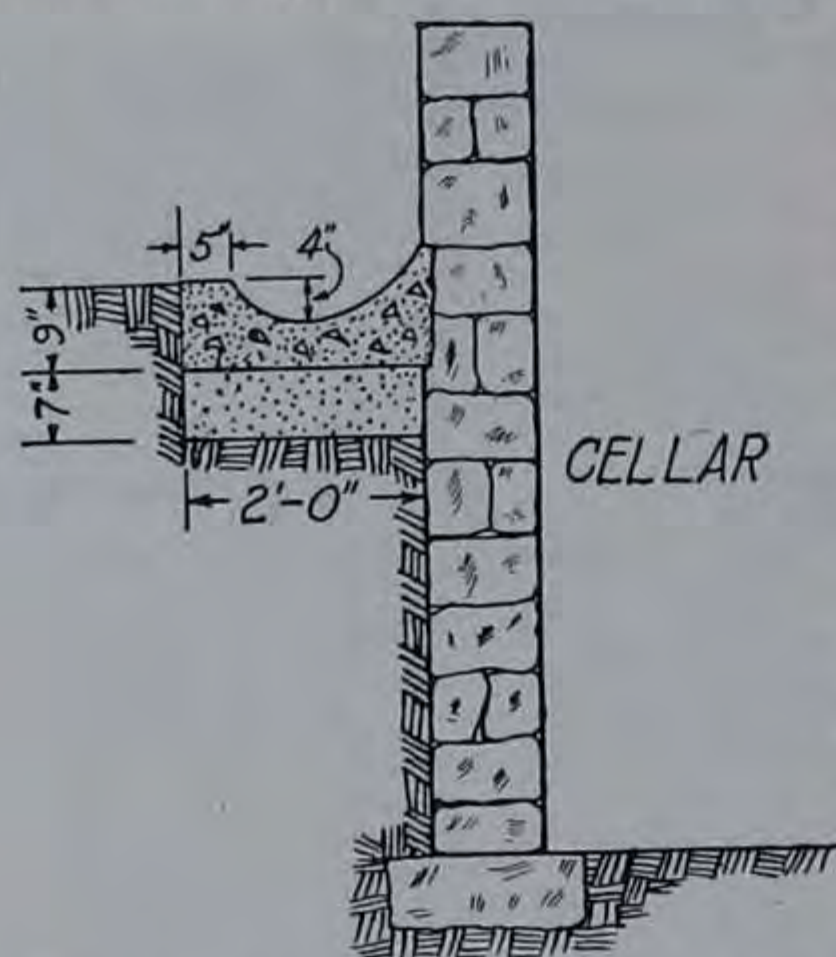

FIG. 6.—Conducting Water Along a Cellar Wall.

Where water from the eaves and sides of a building must be conducted along a cellar wall, a concrete gutter of the cross-section shown and laid to a smooth slope or fall of one-eighth inch or more for each foot of length will prove of service.

galvanized-iron pipe, or a few lengths of vitrified channel pipe.

The reader will notice that the purpose of all these measures is to throw surface water away from the cellar wall quickly. Where this can be done the chances are good that the water will sink to the great reservoir of ground water before it can spread laterally to the cellar. As between the vertical movement and the horizontal movement of percolating water, the former, especially in porous soils, is likely to be much the more rapid. For example, water applied at

the surface of a very dry undisturbed sandy soil penetrated to a depth of 6 feet in 24 hours, but the lateral movement was only about 2 feet.

## DAMP-PROOFING.

(b) Where the bottom or the walls of a cellar are within reach of capillary water only, dampness, not standing water, is the consequent effect. None of the methods heretofore described nor drainage is of use. Capillary water may be intercepted in one of two different ways; namely, by introducing plenty of free air space or by damp-proofing the floors and walls. Figure 11 shows two methods in common use for keeping capillary water away from cellar floors. If it be desired to omit the stone insulation shown in the upper cut of figure 11 and lay the concrete directly on the ground, a richer mixture should be used and the thickness may be increased an inch. A 5-inch floor of concrete mixed 1:2:3, or even a little leaner, and put

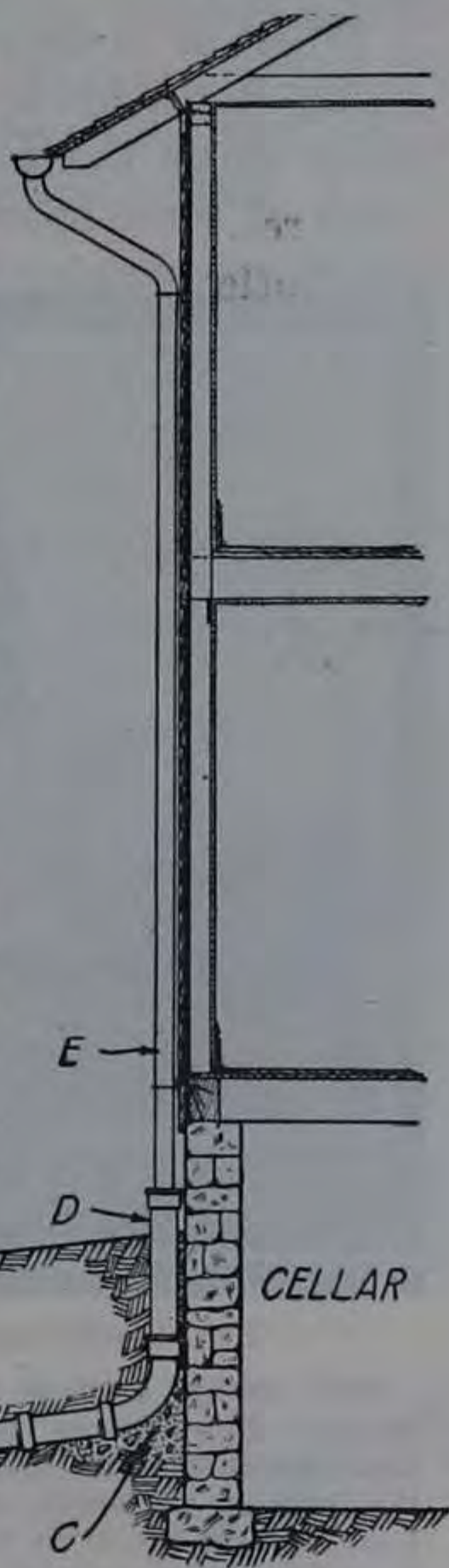

FIG. 7.—How to Waste Roof Water.

Showing use of a dry well or an abandoned well in which to waste roof water. *A*, Dry well; locate 15 or more feet from the cellar and on lower ground; carry excavation to a porous stratum, preferably one lower than the cellar bottom; curb excavation with field stone, rubble, or brick laid without mortar; cover the curb with a concrete slab, covering stone, or heavy cross planking 1 foot below the surface of the ground; sometimes an excavation is merely filled with coarse gravel, bowlders, broken stone, brick, slag, or other similar waste materials. *B*, Four-inch drain tile or vitrified sewer pipe, closed joints, laid about 2 feet below the ground surface. *C*, Concrete bedding to hold elbow in place. *D*, Short piece of 4-inch cast-iron pipe. *E*, Rain conductor or down spout.

down in workmanlike manner with the top troweled to a hard glassy surface, is practically impervious to moisture and will even withstand small pressures of water.

Where it is desired to reduce or prevent dampness in existing stone, brick, or concrete walls and floors, or to shed water down the walls, the simplest method is to apply two coats of some specially prepared damp-proofing paint. As



FIG. 8.—Where Roof Water Worked into the Cellar.

Well graded grounds that seemingly would shed water like a policeman's helmet. Nevertheless, rain water worked into the cellar, the cause being a down spout that discharged on the surface at the rear right-hand corner of the house. Curiously, the trouble occurred on the down hill side of the house, where the slope away was excellent. Method of removing the trouble is told in figs. 9 and 10.

in all painting operations, the surface to be treated should be thoroughly clean and dry and the paint be brushed into all pores, hair cracks, and inequalities, leaving a smooth continuous coating throughout. One gallon of concrete paint will double-cover from 50 to 125 square feet of masonry surface, depending on its roughness and porosity. For cellar interior work, white walls and light gray enamel on the floor give a neat, pleasing effect. Under ordinary wear and use a floor so treated does not become gritty; a broom or mop works on it without "drag," and hence the labor of cleaning or washing is much lightened.

Where a painted floor is subject to heavy or continual wear some sort of protective coating is necessary. A thick plastering of richly mixed, smooth-troweled Portland cement mortar frequently is used for this purpose. Similar treatment of the outside of walls, both above and below the ground surface, is a great aid in protecting the damp-proofing coating, and preventing flaking and peeling. Figure

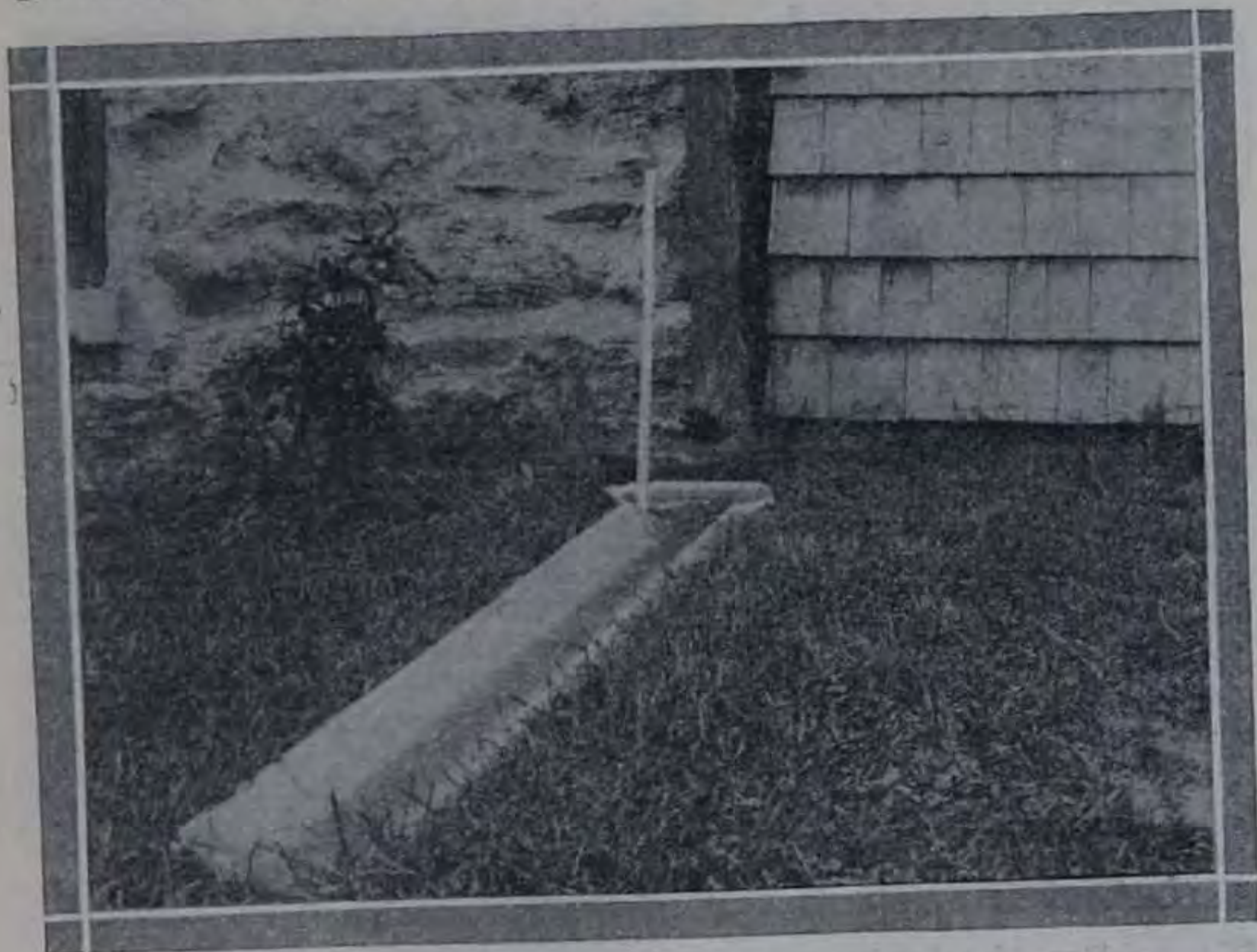

FIG. 9.—How to Lead Roof Water Away from the House.

Homemade, half-round concrete gutter about 8 inches wide and 6 feet long. The edges next the grass are about 2 inches thick and the waterway beneath the down spout is widened to resemble a shallow platter. A kennel is at the right of the down spout and at the left a 2-foot rule leans against the cellar wall.

12 shows the application of a heavy, penetrating bituminous damp-proofing paint to a brick wall and the subsequently applied plaster coat.

Figure 13 shows the use of a large brush in applying heavy-bodied bituminous or asphaltic coatings to the outside of cellar walls. A further development of the process is shown in figure 14. Here a priming and bonding coat of liquid bitumen, mixed with a strong penetrating solvent, is being applied cold with a brush, and after the primer is dry, a heavy tough bitumen compound is swabbed on hot



with a roofing mop. This method is used extensively, not only to prevent the absorption of moisture, but to shed seepage down walls. For use under moderate temperature conditions a primer of creosote oil may be used, followed by a coating of coal-tar pitch applied with a mop.

Where the use of damp-proofing paints and coatings is contemplated, one should get full directions and specifica-

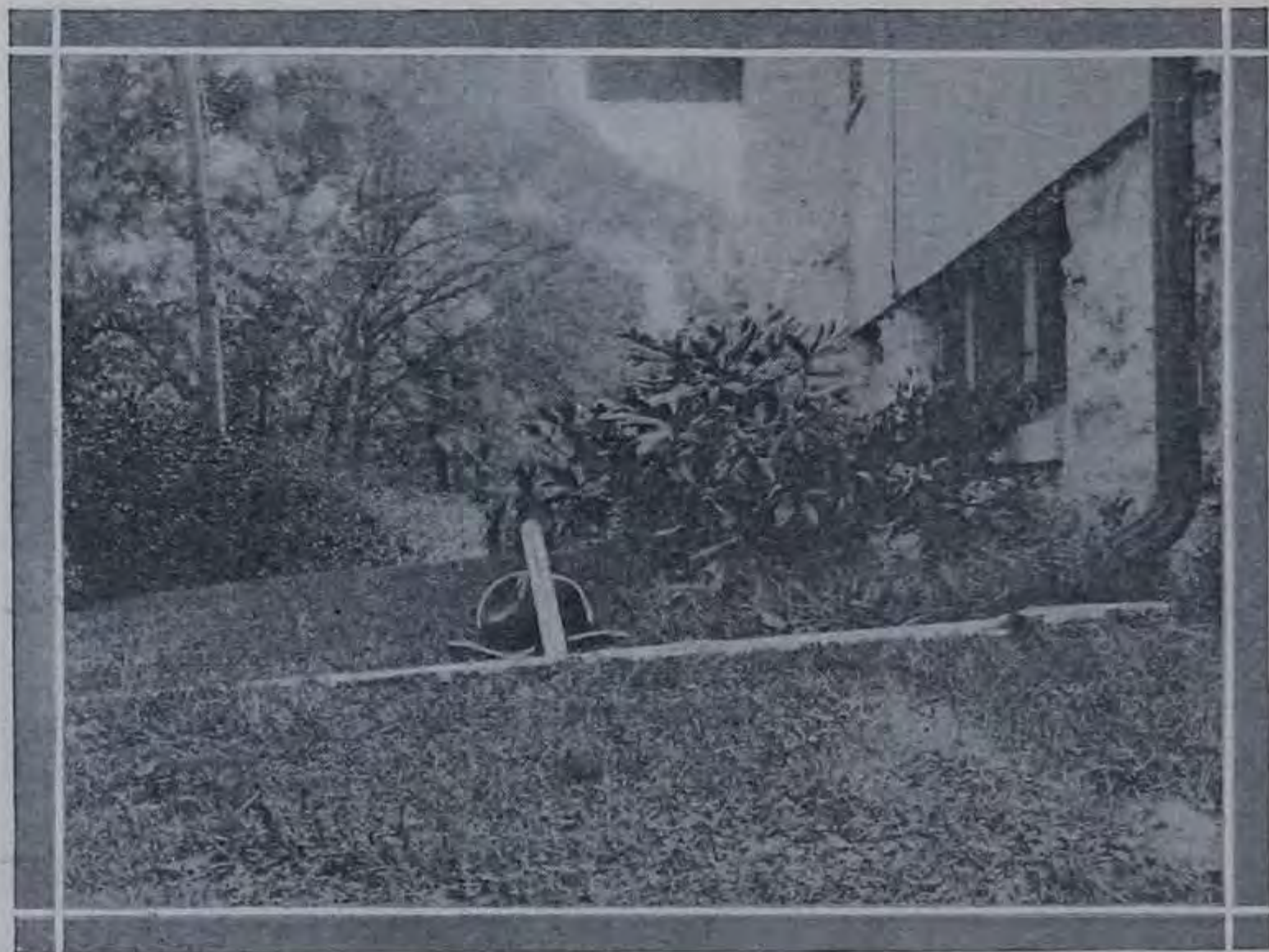

FIG. 10.—Looking Across the Gutter Shown in Fig. 9.

Note that the gutter is almost flush with the ground surface, and hence is slight obstruction to the foot or to a lawn mower. The hat, with a foot rule leaning against it, is about midway of the length of the gutter.

tions from a reliable manufacturer whose materials are to be employed. Other methods of damp-proofing are discussed later under waterproofing.

(*c*) Where a cellar bottom is below the water table and a drainage outlet can be obtained within reasonable distance, a drain should always be constructed for removal of the ground water at least as low as the bottom of foundation walls and the under side of floors. This is a wise precaution, even where special waterproofing measures are to be employed.

Figure 15 shows a 4-inch tile drain laid 6 inches below and outside of a cellar wall. The pipe should be sound,

hard-burned, or vitrified drain tile or ordinary sewer pipe with socket joints. Nothing smaller than 4-inch should be laid. The grade or fall should be smooth, and to guard against settlement of clay, silt, or mud within the pipe it should be as great as possible. If it is certain that only clear water will enter the pipe the grade may be as flat as 3 inches in 100 feet. Each pipe should be carefully bedded

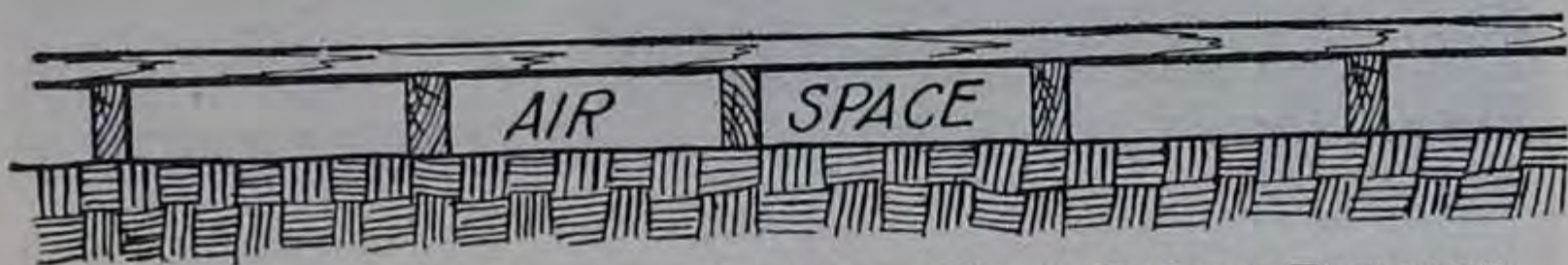
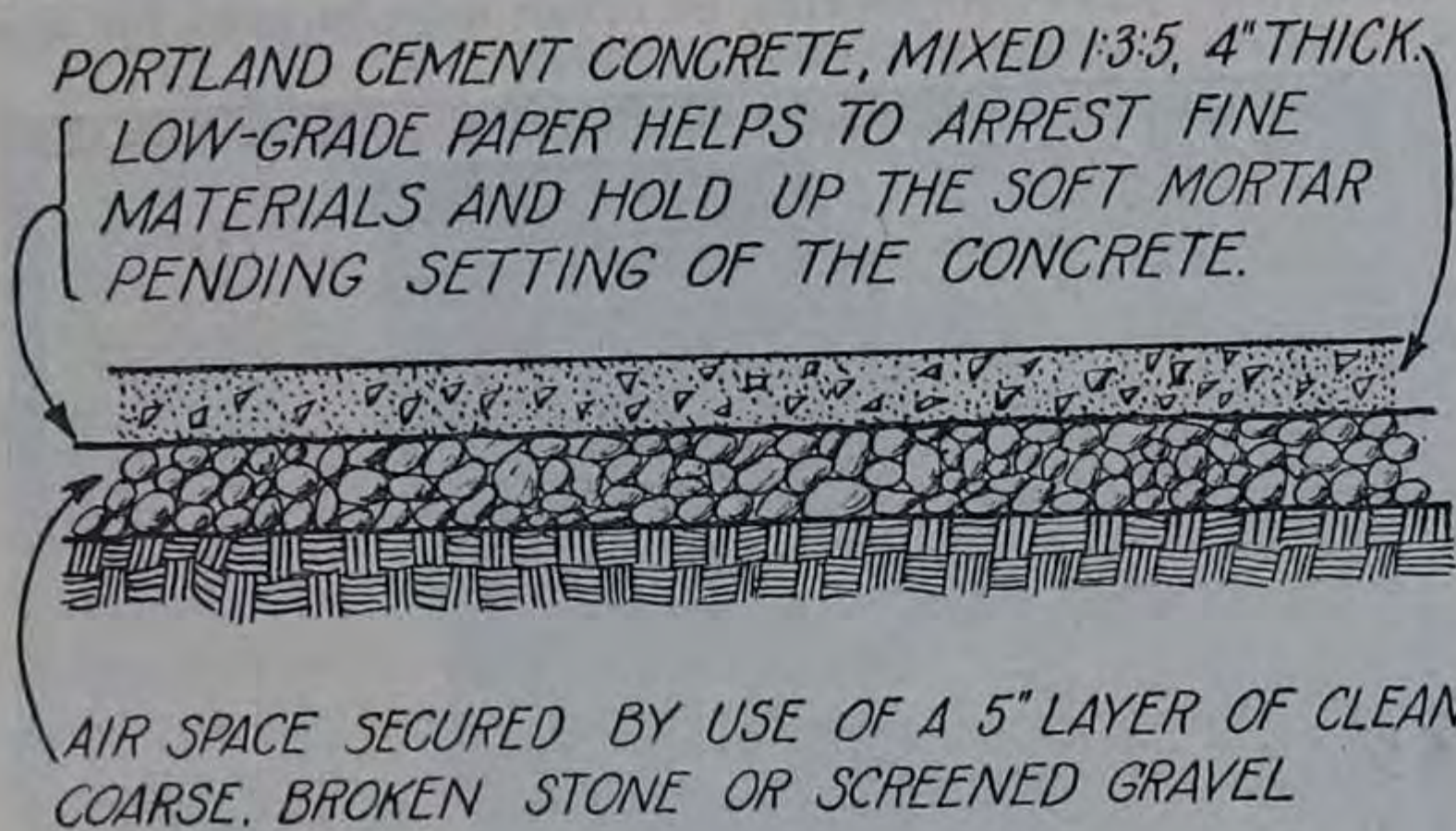

FIG. 11.—Air-Filled Space under Cellar Floors Reduces Dampness.

Two methods of intercepting capillary water and reducing dampness. In both the essential principle is that of an abundance of air-filled space. The wooden floor is open to the objection that it is not permanent and offers refuge for rats and vermin.

its full length so as to avoid uneven loading and the liability to breakage. The joints should be kept open about the thickness of a knife blade and to prevent entrance of loose earth should be encircled with strips of burlap or other similar material about 6 inches wide and 15 inches long. That the burlap may not be dislodged it should be wired or tied on with two pieces of string, one on each side of the joint. Sometimes strips of tarred paper or specially constructed earthenware gutter and cap pieces are used for

protecting the joints. The pipe should be surrounded and protected with fine clean screened gravel or broken stone, after which similar but coarser material, say, one-half inch to 1-inch size, should be used to cover the top of the pipe to a depth of a foot. Over the top of the broken stone it is well to spread burlap or bagging to prevent fine material falling or washing down into the stone. Sods, grass side down, hay, straw, cornstalks, or brush may be used for this



FIG. 12.—Damp-Proofing Paint and Plaster Coat.

Application of a heavy, penetrating, tacky, bonding and damp-proofing paint to a brick wall. The plaster coat is troweled directly on the painted surface, thus protecting the paint and preventing flaking and peeling.

purpose with fair success. Where a building is located on a hillside and the soil against the cellar wall is likely to be saturated, the coarse stone filling should be brought up to near the surface of the ground and the top soil be placed, graded, and seeded in the usual way. A belt that not only collects ground water but effectually intercepts both seepage and capillary water is thus placed around the cellar or on those sides whence the flow comes. If the site of the cellar is very soft or springy two or three parallel branch drains should be laid beneath the cellar floor.

Figure 16 shows how a man in Maryland made use of the house sewer for lowering the ground water beneath his cellar. Usually it is not permissible to discharge ground water into a sanitary sewer, but circumstances may make it advisable.

Figure 17 shows a type of drain that should not be used. It is located about 6 inches inside the cellar wall and drainage is conducted to

a low point in the cellar and thence through the wall to an outlet. Drains of this kind prevent submergence of the cellar floor, but do not prevent excessive dampness. The writer has seen in high mountainous locations and in the dry season of the year cellars having good concrete floors, but drained in the manner just described, so wet that drops of water hung from the floor beams; and hanging shelves, when punctured with a knife, exuded water freely.



FIG. 13.—Bituminous or Asphaltic Coating.

Use of a large brush in applying heavy-bodied bituminous or asphaltic coatings to the outside of cellar walls. Sometimes the coating fails to take hold and later flakes off or comes off in patches. This is due to chilling and solidifying of the compound when brought in contact with a cold masonry surface. It is very important that the penetration be deep, the adhesion be complete, and a continuous, well-knit coat be spread. Where the conditions are severe, two coats are advisable.

#### WATERPROOFING.

(*d*) Where a cellar bottom is below the water table and a drainage outlet can not be secured, waterproof construction is required. Successful waterproofing is a man's job, and calls for all the ingenuity the householder can exercise or command. A cellar may be water-

tight to-day and leak badly 1 year or 10 years hence. A volume could be written on the subject, but this paper will merely discuss a few of the most important points.

Two principal methods of waterproofing are in use, namely, the integral and the membrane. In the integral method mixtures or compounds containing some such substance as clay, hydrated lime, sodium silicate, soda, lye, alum, paraffin, wax, soap, or oil are incorporated in the con-



FIG. 14.—Damp-Proofing the Outside of a Cellar Wall.

On the left, application of a penetrating, bituminous, priming and bonding coat cold with a brush. After the primer is set and dry, a bituminous compound is melted in large kettles and is swabbed on hot with a roofing mop as shown on the right. The coating should be thick, tough, and somewhat elastic and yielding.

crete or mortar during the mixing. In the membrane method a specially prepared felt, cotton drilling, or other approved fabric is put down in overlapping layers, coated and cemented together with hot coal-tar pitch or other bituminous compound, the whole forming, or intended to form, virtually a water-tight box in which the masonry is set.

**INTEGRAL METHOD.**—Some of the preparations used in the integral method of waterproofing depend on the void-filling

action of their finely divided particles, but others naturally repel water in the same manner that neat's-foot oil turns water from a boot. Some of the preparations in the form of

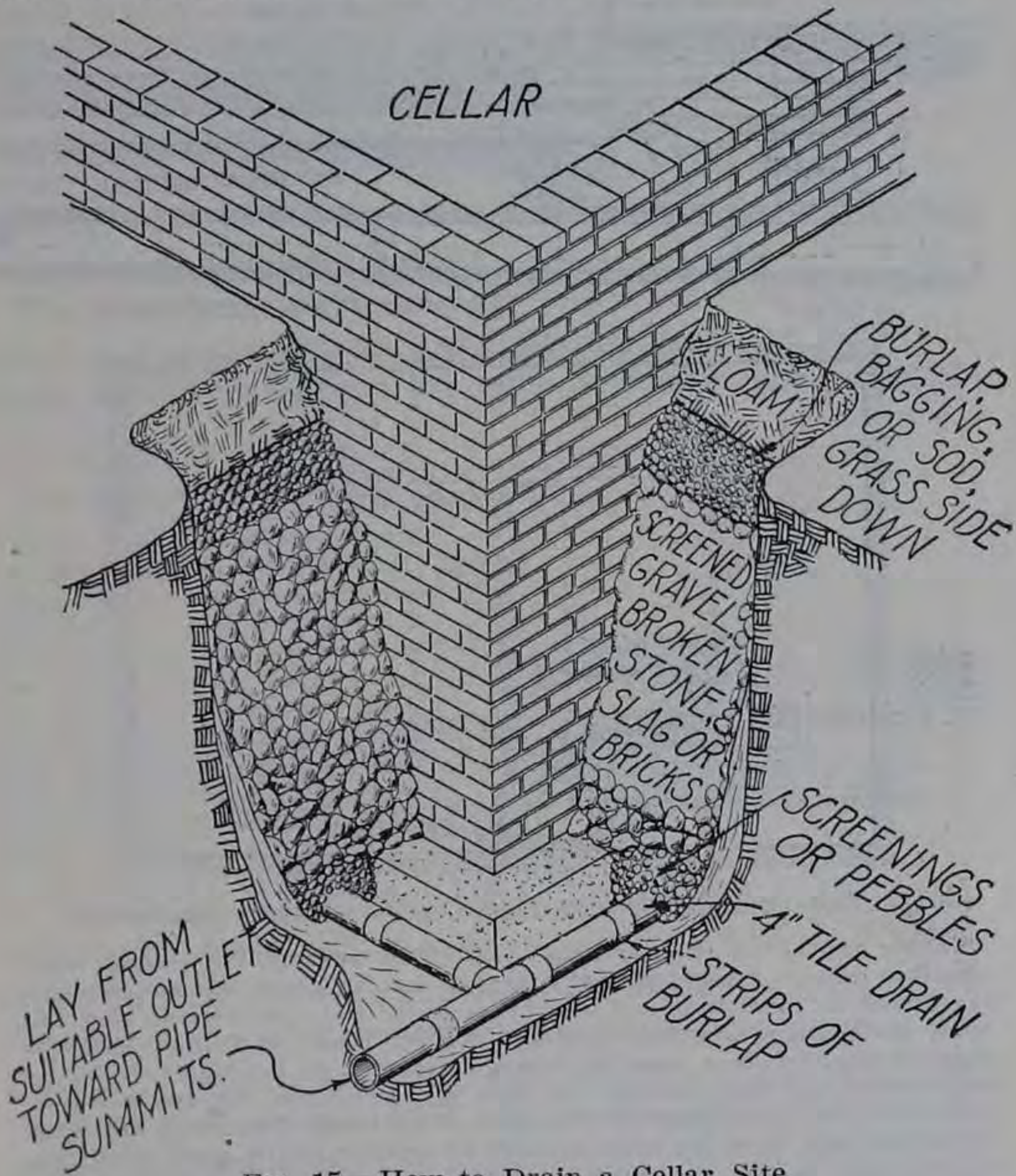

FIG. 15.—How to Drain a Cellar Site.

Four-inch tile drain laid on straight lines and smooth grades about 10 inches outside of the foundation and 6 inches below its bottom. Refilling the trench with coarse material to the loam filling places a belt about the cellar that effectually removes ground water and intercepts both seepage and capillary water.

a whitish powder are mixed dry with the cement, and others in paste or liquid form are added to the water. The investigations of the Bureau of Public Roads have shown that petroleum residuum possessing certain characteristics (the

specifications allow paraffin base and mixed base oils but do not allow highly asphaltic oils) can be used successfully for both damp-proofing and waterproofing under light pressures,

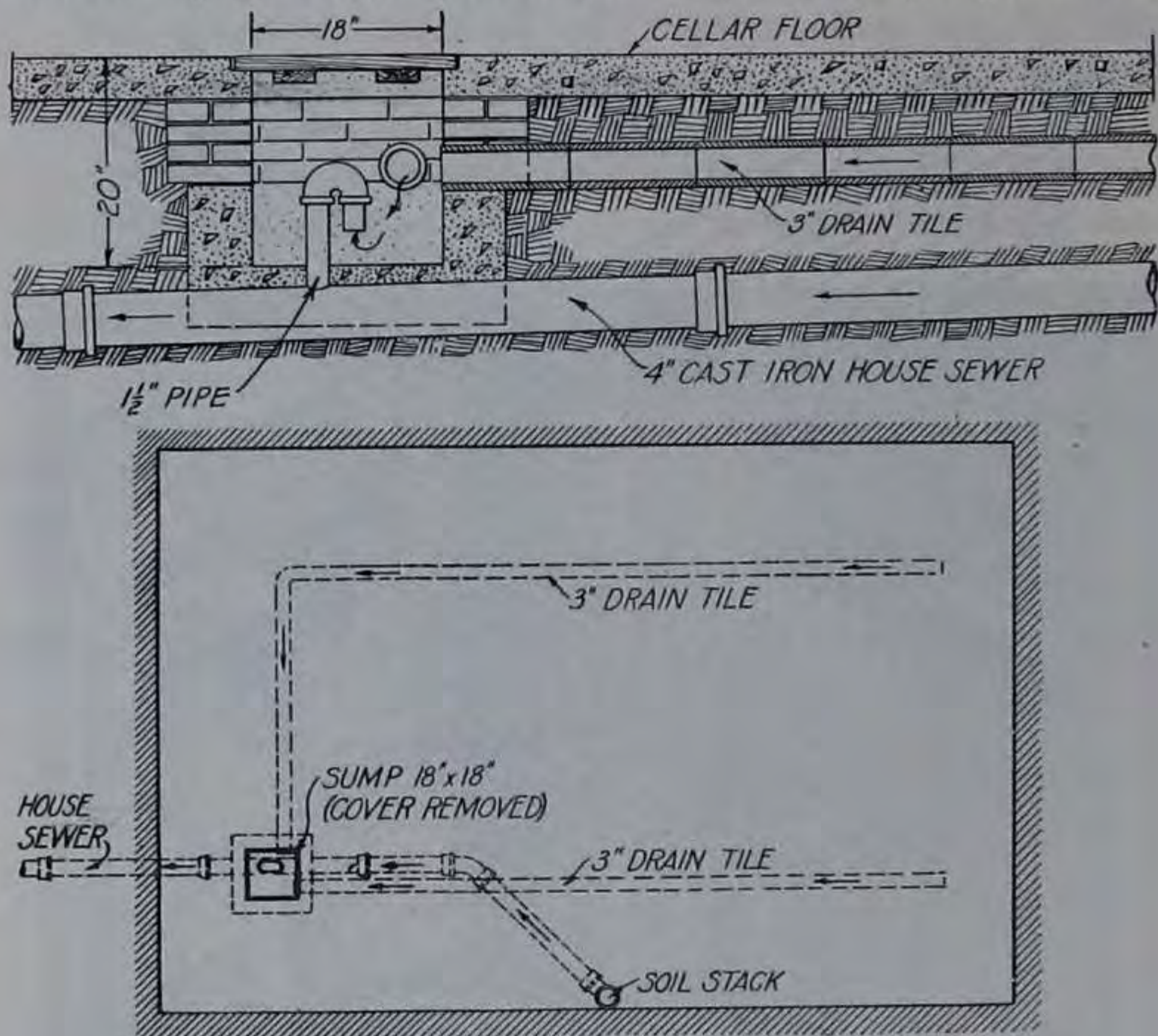

FIG. 16.—Draining through House Sewer—Rarely Advisable.

Making use of an existing house sewer for lowering the ground water beneath a cellar. A hole sufficiently large to take a 1 1/2-inch wrought iron pipe was drilled in the 4-inch cast-iron house sewer and a homemade trap and outlet consisting of a return bend and 2 short pieces of 1 1/2-inch pipe were installed as shown in a sump 18 inches square and 20 inches deep. Ground water enters the sump through two lines of 3-inch drain tile and the open-joint brick work composing all four sides of the upper portion of the sump. Below the brick work the sump is made of concrete and is water-tight, thus securing seal against the emission of foul air from the sewer. Use of a sanitary sewer for the removal of ground water is rarely advisable. Such sewers are seldom designed to handle ground water and other objections relate to the liability of sewage backing up into the cellar and leakage or evaporation destroying the water seal in the sump. If employed, the method should be considered for temporary use only, and the certainty of the water seal should be proved by frequent inspection.

and the subject is concisely treated in Department Bulletin 230, "Oil-Mixed Portland Cement Concrete," copies of which may be had upon request.

Probably no one knows which of the many preparations is the best. With the successes are many failures, caused

in part by inherent weakness of the method and in part by faulty workmanship in mixing and placing the concrete. Much of the trouble comes at construction joints and at cracks caused by settlement, shrinkage, temperature changes, and other agencies. At these points integral waterproofing fails. But where, as so frequently happens, a lean, raw concrete is carelessly placed, perhaps in the expectation that water under pressure from beneath or the back can be "smothered," failure is certain, nor can such failures be attributed to the integral method.

The fact needs to be strongly impressed that no waterproofing preparation can make amends for a concrete that is not dense and uniform throughout; that is, honeycombed

FIG. 17.—A Type of Drain that Should not be Used.

These are located just inside the cellar wall and may be half-round tile, a mere groove in the concrete, or a small stone-filled ditch draining to a low point in the cellar, and from thence through the wall to an outlet. Though drains of this kind prevent submergence of the cellar floor, they do not prevent excessive dampness in all parts of the cellar.

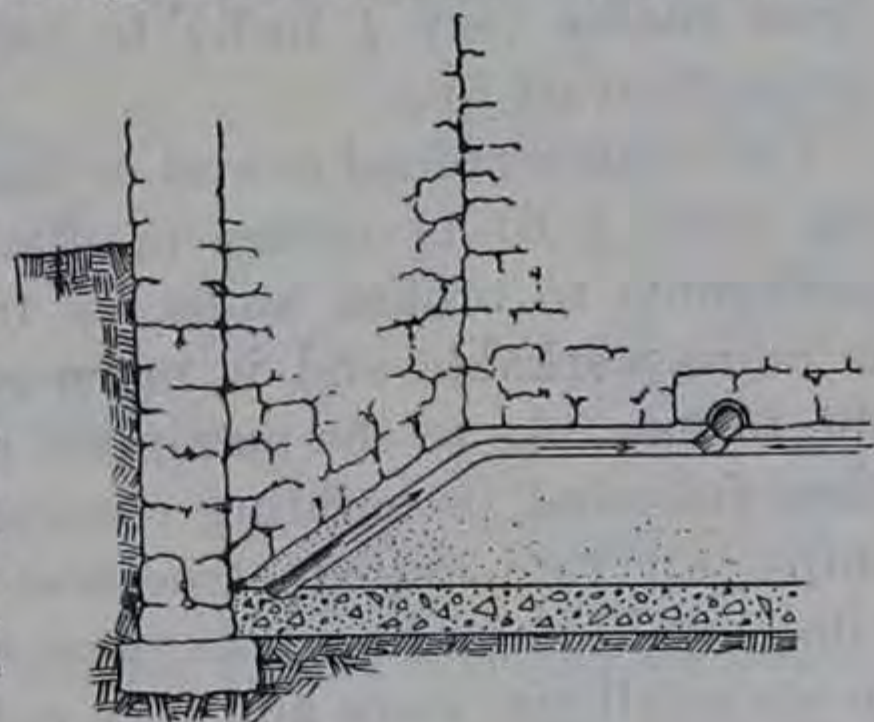

or containing pockets of stone, sand, water, or air. Concrete to be dense and impervious requires first-class materials and workmanship, and in so far as these are employed the need of special waterproofing mixtures and compounds is lessened. Indeed, assuming that cement, sand, and stone are so graded and combined with water as to produce a concrete of maximum density, the principal effect of certain substances used for waterproofing may be mere increase of the volume, an effect that would be produced by introducing almost any foreign substance.

*Water-tight concrete.*—The following directions will be found of great practical value in building water-tight concrete floors and walls.

Start the work in mild weather and during the driest season of the year, when the ground water is the lowest. If necessary in order to eliminate all hydrostatic pressure



against newly placed concrete, a sump or hole must be sunk at one corner of the cellar excavation and the ground water be lowered by pumping.

Use a recent shipment of Portland cement of established reputation.

Use clean sand—that is, such as contains little or no clay, silt, loam, or vegetable matter. Where bank, pit, beach, or river-bottom sand is not available, a suitable sand is often obtained by use of a gravel screen. The best type of screen has longitudinal wires spaced about  $\frac{1}{4}$  inch on centers, with horizontal wires 4 to 6 inches apart to act as stiffeners. If such a screen is not available the ordinary  $\frac{1}{4}$ -inch square mesh will answer. The size of the sand grains should grade from coarse (say  $\frac{1}{8}$  inch) to very fine, but with a goodly proportion of fine.

Use clean screened gravel or broken stone, the pieces varying from  $\frac{1}{4}$  to  $1\frac{1}{4}$  inches in diameter. Screened gravel is preferable to broken stone, as from its rounded nature it is more workable and is more easily settled into place in the forms. As to the maximum size of the stone, the practices followed in building concrete standpipes, barges, and ships, all thin-walled structures where water-tightness is vital, are illuminating. In these works the practice has been to use small-size stone and very rich mixtures. For example, the Emergency Fleet Corporation has used, as the stone constituent,  $\frac{3}{8}$ -inch washed gravel mixed with 50 per cent coarse washed grit, the concrete being proportioned 1 volume cement,  $\frac{2}{3}$  volume sand, and  $1\frac{1}{3}$  volumes of the mixed gravel. In other vessels a burnt shale-clay crushed to  $\frac{1}{4}$  and  $\frac{1}{2}$  inch sizes proved acceptable and, furthermore, when used in proportions to give a 1:2 concrete (1 of cement to 2 of sand and gravel combined) resulted in a product weighing 118 pounds or less per cubic foot instead of the usual weight of about 150 pounds. In barge construction, broken stone sizing up to  $\frac{5}{8}$ -inch diameter and mixed in the proportions 1:1:2 has given satisfaction. In standpipe construction use of somewhat larger stone has usually been permitted, but invariably the mix has been rich, say, 1:1:2 or  $1:1\frac{1}{2}:3$ . Never use bank-run gravel, as the proportions of sand and gravel are unknown.

Having at hand good cement, clean water, clean sand that grades from very fine to  $\frac{1}{8}$  inch, and clean gravel that grades from  $\frac{1}{4}$  to  $1\frac{1}{4}$  inches, the work of mixing and placing the concrete may be begun. Hand mixing is customary on small jobs. For this purpose a level, practically water-tight platform or mixing board, and two bottomless boxes or frames for measurement of the sand and gravel are necessary. Concrete, proportioned 1 volume cement, 2 volumes sand, and 3 volumes stone (usually written 1:2:3) is recommended. Though this is not as rich as is used in the ship work previously mentioned, it provides an abundance of good mortar, something that is vital in the elimination of void spaces and

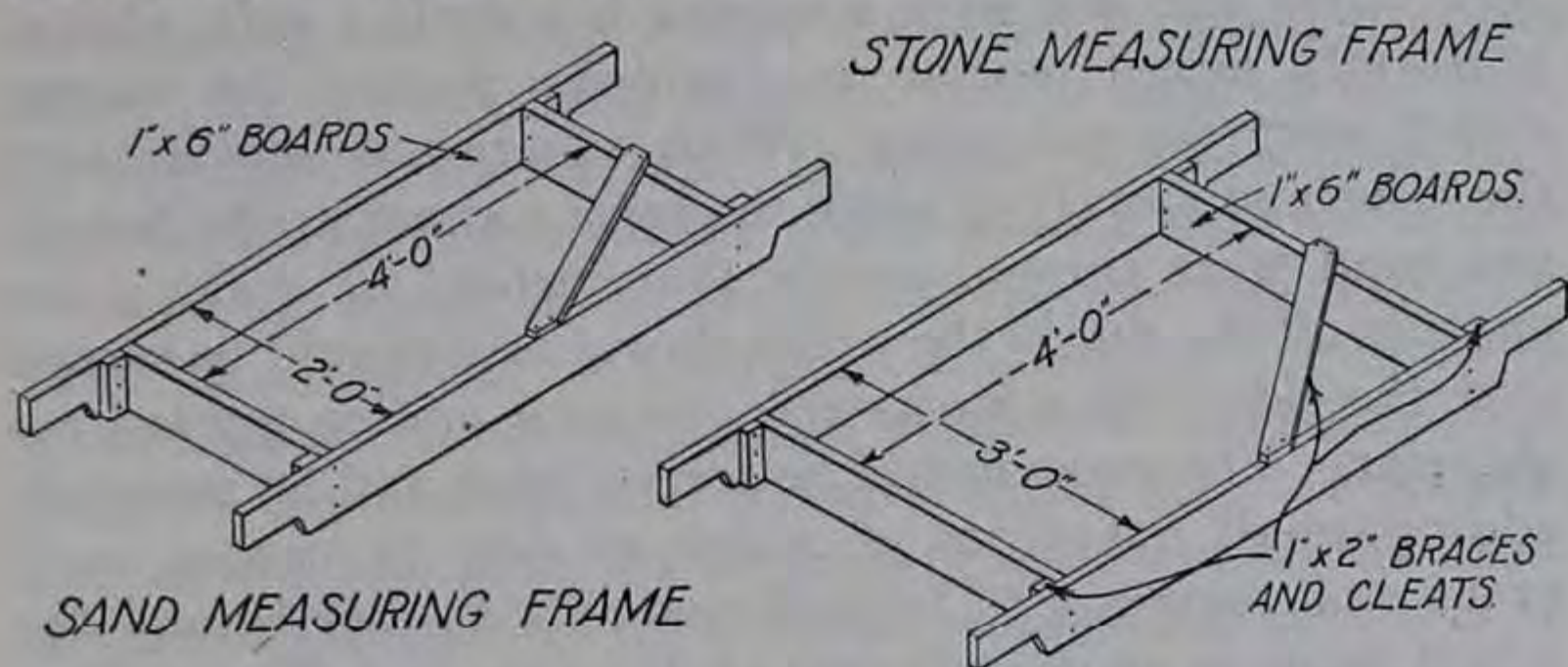

FIG. 18.—Sand and Stone Measuring Frames or Bottomless Boxes.

The dimensions shown are for half-barrel (2-bag) batches mixed in the proportions 1:2:3 (1 volume cement, 2 volumes sand, 3 volumes stone).

in securing water-tightness. If the concrete is to be mixed in half-barrel (2 bags) batches, a suitable size of platform is 10 feet square. There should be sufficient supporting pieces or battens to prevent sag of the boards, and a strip may be nailed along the outside edges to prevent loss of liquid cement. A half-barrel, or 2 bags, of cement contains approximately 2 cubic feet. Hence, to obtain the proportions 1:2:3, the sand and stone measuring frames must contain, respectively, 4 cubic feet and 6 cubic feet. Square-edge boards 1 inch thick and 6 inches wide may be used conveniently for making the frames as dimensioned in figure 18. Never guess at the proper quantities of cement, sand, and stone, and never use the inaccurate method of measuring by shovel-fuls or by wheelbarrow loads.

Place the two frames with their long sides parallel and about 2 feet apart on the platform. Fill the smaller frame

with sand and the larger with stone previously drenched, both level full. Lift off both frames. Empty the half barrel or two bags of cement over the sand and spread it evenly with a garden rake or mortar hoe. Thoroughly mix the dry sand and cement. Starting at opposite ends of the pile and working toward each other, two men with square-end shovels should turn the sand and cement from the bottom upward. In turning the shovel the materials should be shaken off the end and sides of the shovel so that they mix in falling. Continue this process till the mixture is of uniform color throughout. Mound the mixture slightly and with a mortar hoe make a craterlike opening in the top. Add water and stir with a mortar hoe until a soft, plastic, uniformly mixed mortar is obtained. Spread the mortar evenly over the wet stone. With square-end shovels turn the stone and mortar in much the same manner as the cement and sand were turned, except that instead of shaking the mixture off the shovel the whole shovel load should be turned over the side with a backward sweeping motion toward the shoveler. The mass should be turned back and be returned, adding small quantities of water as may be needed until every stone appears to be well coated with mortar and the whole mass is uniformly mixed throughout. The mixing can not be slighted.

The water used in mixing gives concrete its consistency and makes it workable. The quantity used has a very important bearing on the water-tightness of the finished work. If the mix is too dry the concrete will be porous and ragged; if too wet the gluelike action of the cement is weakened and the mortar and stones tend to separate, leaving stone pockets through the mass and causing poor distribution of the cementing or bonding constituent. For example, an excess of paste (cement and water) on the top of newly-placed concrete means that some adjacent portion of the mass is just that much poorer in its bonding constituent. What is wanted is a consistency that will permit a sluggish flow to all parts of the form and when the concrete has been settled by a reasonable amount of spading and tamping there should be a small even flush over the entire surface.

If it is desired to mix barrel, or 4-bag, batches make the platform larger and double the capacity of the sand and stone-measuring frames, or use those shown in figure 18

twice. For 1 cubic yard of rammed concrete there will be required about  $1\frac{2}{3}$  barrels of cement,  $\frac{1}{2}$  cubic yard of sand, and  $\frac{3}{4}$  of a cubic yard of stone. The volume of rammed concrete from 1 barrel (4 cubic feet) of cement, 8 cubic feet of sand, and 12 cubic feet of stone (40 per cent voids) will be about 16.2 cubic feet.

As soon as mixed, pour the concrete and continue the operations without stopping till all work below the water line is completed. During the pouring the forms should be tapped constantly with wooden mallets to release air bubbles. At corners and against the faces of forms special care is required. Working a spade or flattened shovel up and down along the forms pushes the stone back slightly and allows the grout (liquid cement) to flow against the face, leaving the surface smooth. In narrow places a piece of 2 by 3 inch scantling, with the upper portion rounded so that it may be grasped readily, makes a cheap and useful tool for puddling, joggling, or tamping. Do not ram or tamp so much that the stones are wedged together at the bottom and much of the finer material is forced to the top. If possible pour at one time all of the concrete necessary to fill the form, so that no portion sets before fresh concrete has been laid on top of it. Where new work joins old work, and in joints between two days' work, the bond requires especial attention. The old surface must be cleaned of all dirt and mortar down to the stone, and the surface soaked with water. Smooth surfaces must be roughened. The joint should then be given a one-eighth-inch coating of neat cement paste and the new concrete be placed immediately.

After concrete has been placed it always should be protected from sunlight, frost, strong winds and excessive heat, any of which would rob it of its moisture. It is equally important that it be not exposed to water in motion or under pressure till it has hardened sufficiently to prevent washing away the mortar. After concrete is sufficiently firm to remove the forms, keep it wet continually for 10 days or more. This means thorough saturation or submergence, not an occasional sprinkling.

The upward water pressure on concrete floors must be considered and a sufficient amount of steel reinforcement in the form of rods, bars, heavy wire netting, or old rails be embedded to resist upheaval.

*Plaster coats.*—Plaster coats on old work rarely are successful because of poor bonding, scaling off, and formation of contraction cracks. Such work should be done when the concrete is green, and skilled workmen should be employed. Plastering the back of a wall is more effective than plastering the face. In any event before attempting to apply a plaster

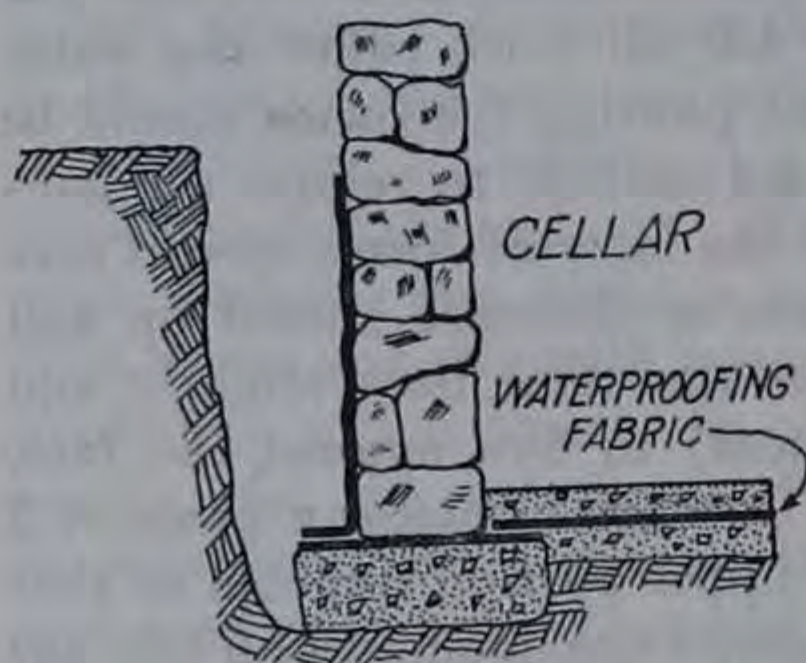

FIG. 19.—Faulty Application of the Membrane Method of Waterproofing.

The surface to which the fabric is applied is too rough, the wall waterproofing is unprotected, nor is it carried sufficiently high to exclude surface drainage, the single-bond joints between the wall and floor waterproofing should not be the sole dependence, and more working space should be provided in which to make this vital connection.

The surface then should be brushed with a wire or stiff scrubbing brush to remove any particles of sand that may have become loosened because of the dissolving of the cement.

To strengthen the bond it will be well to apply a wash of grout, made by mixing cement with water to the consistency of cream. All large holes or openings must be filled with cement mortar. A plaster coat composed of 1 part of Portland cement and 1 or 2 parts of sand may then be applied. Oil or other waterproofing compound may be incorporated with the mortar, and if applied in two coats to a total thickness of 1 inch and both coats thoroughly troweled, the results may be fairly satisfactory. The new surface should be kept wet for at least a week. Leaks at pin holes are sometimes stopped by the use of wooden plugs or caulking with lead wool.

coat the old work should be scrubbed clean and should be made thoroughly wet. The bond between the old and new work will be improved if the old surface be roughened with a stone hammer. A wash composed of 1 part of hydrochloric acid and 5 parts of water may be used to clean the surface. This will dissolve some of the cement from the old work, leaving the aggregate exposed. The acid solution should be left on not longer than half an hour, when it should be removed completely with clean wa-

**MEMBRANE METHOD.**—The membrane system of waterproofing—that is, the building of a virtually water-tight box composed of overlapping and coated strips of felt or other fabric, is a reliable method if the work is done by experienced persons. Disadvantages of the method are that it is costly and if leaks do develop they are difficult to locate and costly to repair. Figure 19 shows a faulty application of the membrane method. The surface to which the membrane is applied should be smooth, the membrane should be protected, and dependence should not be placed on the single bonding shown on either side of the base of the cellar wall. Figure 20 shows a correct application of this method. For small heads of water, 2-layer work should prove effective. Figure 21 shows the details of good spacing and overlapping.

The work always should be done in warm or mild weather. Spread over the excavation a thin bed of concrete or an inch or more of cement mortar. Over this bed swab a coating of hot waterproofing compound. Closely following the swab a prepared felt or fabric is rolled into the hot compound. The sheets must lie perfectly smooth. Wrinkles must be pulled out and the sheets be rubbed and pressed to insure elimination of air bubbles and good adhesion with the compound. The membrane must fit all corners snugly. The laps of the several layers must be cemented together firmly with the hot compound and each layer, including the final, be coated completely, to the end that a strong, thoroughly covered, waterproof blanket may be obtained. The compound always should be applied hot, but care must be used not to overheat it. This is especially true of coal-tar pitch, which has a high percentage of volatile constituents and if overheated becomes brittle and worthless when cold. The membrane should be carried up the interior face of a thin protecting wall of brick, concrete, or stone, after which a wall is built against the waterproofing, the whole constituting the foundation wall.

Where it is impossible to secure local labor that is experienced in cutting and applying membrane waterproofing, get sketches, specifications, and explicit directions from a reliable manufacturer whose materials are to be used. It is advisable to try the materials first on a small upright surface before attempting the real waterproofing work. With

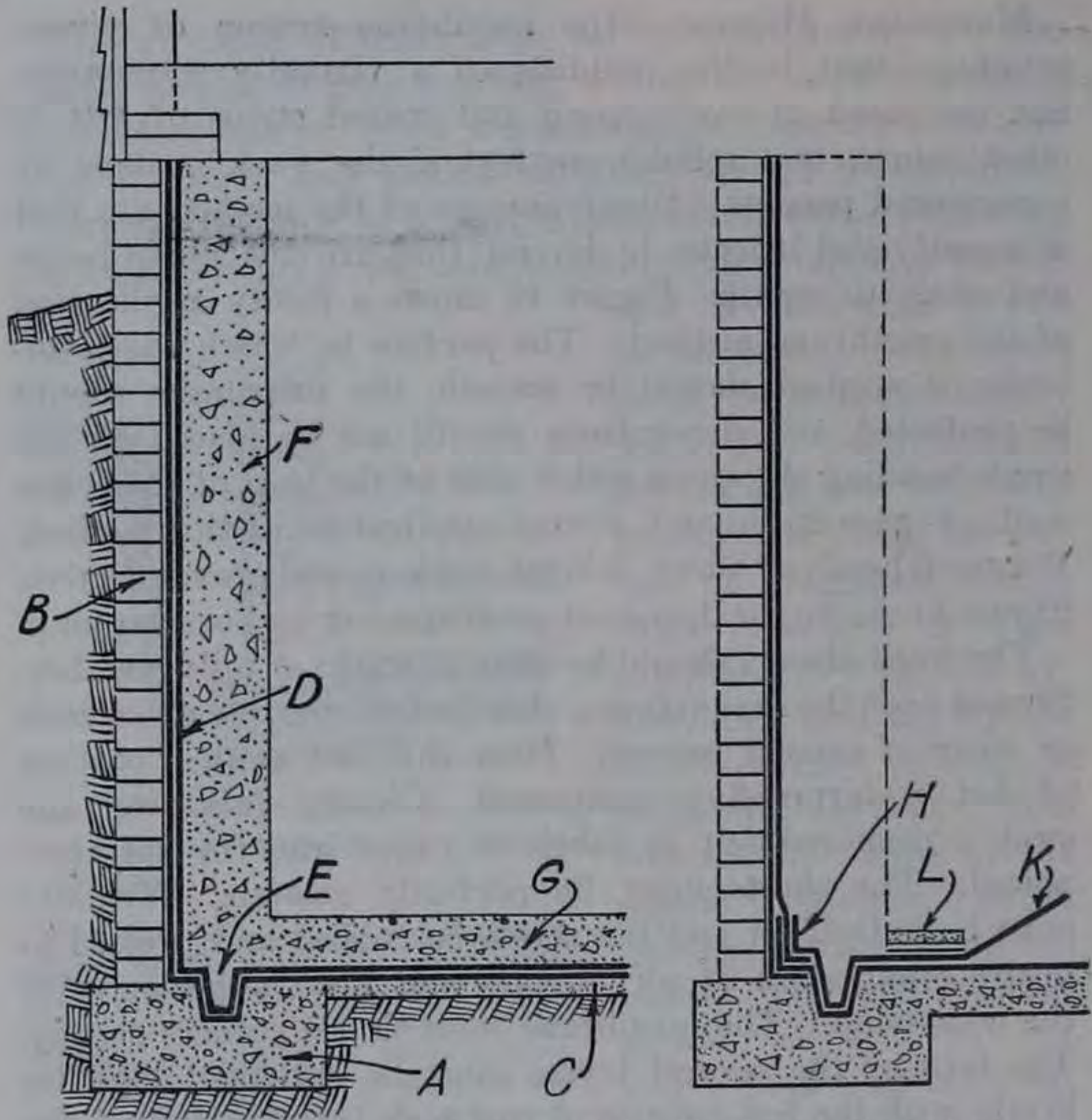

FIG. 20.—Correct Application of the Membrane Method of Waterproofing.

On the left: *A*, Footing course with chamfered groove formed in top to insure bonding. *B*, Thin wall of brick or concrete to which the saturated felt, burlap, cotton drilling, or other fabric is cemented with hot coal-tar pitch, asphaltum, or other suitable bituminous compound; brick walls should have struck joints and concrete walls should be smooth, thus providing a solid even backing for the waterproofing. *C*, One-inch bed of cement mortar or a thin bed of concrete, according to the nature of the conditions. *D*, Two or more layers or sheets of waterproofing, according to the severity of the conditions; under high heads of water two courses of two layers each breaking joints as shown in fig. 21 are employed frequently. *E*, Key completed with brick or stone thickly bedded in cement mortar. *F*, Brick, concrete, or stone wall built against the waterproofing; all space between the wall and waterproofing to be filled with cement mortar or be flushed with Portland cement grout. *G*, Four-inch concrete floor laid directly on the waterproofed fabric.

On the right: Method of interlapping and interlocking courses where it is not possible to waterproof the floor and wall at the same time. This gives a much more dependable bond than that shown in fig. 19. *H*, Footing waterproofing carried 6 inches up the wall. *K*, Six inches of second course laid dry, thus permitting interlapping and interlocking with the floor waterproofing when latter is laid. *L*, Three-fourths inch protective coat of lean cement mortar on a "waster" sheet, both extending over the dry lap; this coat is temporary and is removed when the floor waterproofing is laid, but it should be placed promptly so as to keep the fabric from being injured by wheelbarrows, tools, or careless workmen.

either the integral or the membrane method of waterproofing all pipes passing through floors and walls should be provided with flanges or have other special treatment.

#### MISCELLANEOUS.

In particular situations none of the remedies heretofore described may be feasible. Where water must be pumped from a cellar a variety of simple mechanical devices are available. Generally, these are placed in a pit sunk in one corner of the cellar and are operated by steam or water pressure. At best, they are makeshifts. In other instances

a cellar drain may be subject to backwater from a creek. This difficulty may be overcome by use of a backwater trap, of which several types are manufactured. The essential principle is that of a swinging gate or flap hung so as to close against external pressure and to open when the height of the water inside exceeds the height of that outside.

Cellars should be provided with ample window space protected by screens or narrowly-spaced bars. Adjust the window opening in much the same manner that you would in a room. When the air outside is cool and dry, open the cellar windows freely. When the air is hot or humid close the windows. Admission of warm, moist air results in mildew and condensation of moisture upon the colder surfaces within the cellar.

In some instances dryness of a cellar is promoted by artificial heat and by use of certain substances that possess a strong affinity for moisture. Of these substances, perhaps calcium chloride is the best, and it is said that 1 or 2 pounds placed in an old can or kettle on the cellar bottom is a great aid in abating the dampness of an ordinary cellar.

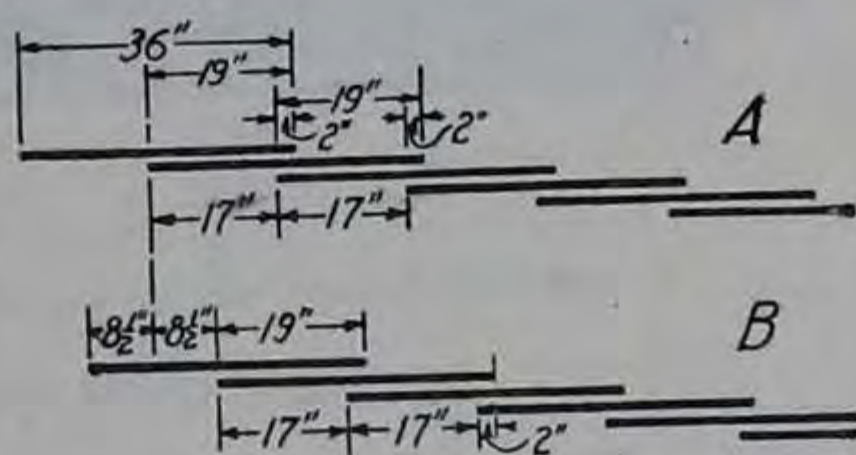

FIG. 21.—Membrane Waterproofing.

Details of longitudinal spacing, overlapping, and jointing of waterproofing fabrics. A, One course of two 36-inch sheets spaced 17 inches and overlapped 19 inches. B, If two courses are laid, the sheets of the second should break joints with the first in the manner shown.



# TRAPPING ON THE FARM



By NED DEARBORN,

*Assistant Biologist, Bureau of Biological Survey.*

## TURNING PESTS INTO PROFITS.

EVERY FARMER finds it necessary to kill certain animal pests in order to keep them from injuring his property or crops. This he sometimes does by means of poison, but more often he employs traps. A knowledge of the traits and habits of the animals and of proved methods of capturing them is important if he is to combat them successfully. Besides such out-and-out pests as rats, mice, and pocket gophers, some other animals are occasionally harmful, but having valuable skins and being classed as fur bearers are given special consideration.

The lively demand for all kinds of fur puts into the pockets of American trappers millions of dollars a year, which, until the harvest, has not cost them a single effort. Moreover, several of the furry tenants of the farmer not only are not pests, but are useful while alive. Foxes, for example, destroy many rabbits and mice, both of which when abundant are very destructive to fruit trees and crops. Skunks are exceedingly beneficial, for they feed almost entirely on mice, grasshoppers, crickets, white grubs, and other farm pests. It is only in exceptional cases that either foxes or skunks attack poultry; it is far better to keep poul-

try in suitable inclosures or to kill the individual animal which is doing damage than to adopt a policy of general persecution toward the tribes to which the few offenders belong.

The food habits of other fur bearers are usually of less importance. Weasels are excellent mousers; minks feed on frogs, fish, mice, and other small animals; while raccoons and opossums eat, in addition to a wide variety of neutral or harmful small animals, many kinds of vegetable food of little or no direct value to man. Muskrats and beavers live on wild products of marshes and woodlands, and only in rare instances are their burrows or houses objectionable.

In short, speaking generally, fur animals transform uncultivated and useless materials into valuable peltries, without expense or attention on our part. They are doing this throughout the country. When the corn is in the crib, and the landscape has been browned by frost, farm lads take down their traps with happy expectation and set out to gather unearned increments of fur.

The purpose of this article is to explain methods of trapping the small wild animals of the farm, methods of preparing skins of fur bearers for market, and methods of improving the fur catch from year to year.

#### HOW TO CATCH PESTS.

The most destructive group of pests on the farm includes the small gnawing animals known as rodents. Among them are house rats and mice which have been brought to this country from the Old World, and several kinds of native rats and mice, as wood rats, rice rats, cotton rats, kangaroo rats, meadow mice, pine mice, white-footed mice, and pocket mice. Ground squirrels of several kinds are found throughout the Western States and in many localities are very destructive to forage and grain. Prairie dogs of the plains region, related to ground squirrels, also destroy a great deal of forage in the vicinity of their "towns." Here and there woodchucks, or groundhogs, also related to ground squirrels, are destructive to field and garden crops. In mountainous and timbered regions porcupines are more or less destructive to orchard and other trees. These animals

are all easy to trap, the main difficulty being that they frequently occur in great numbers.<sup>1</sup>

The styles of traps shown in figure 1 (*A* and *B*) are used extensively in catching all kinds of rats and mice. Such traps

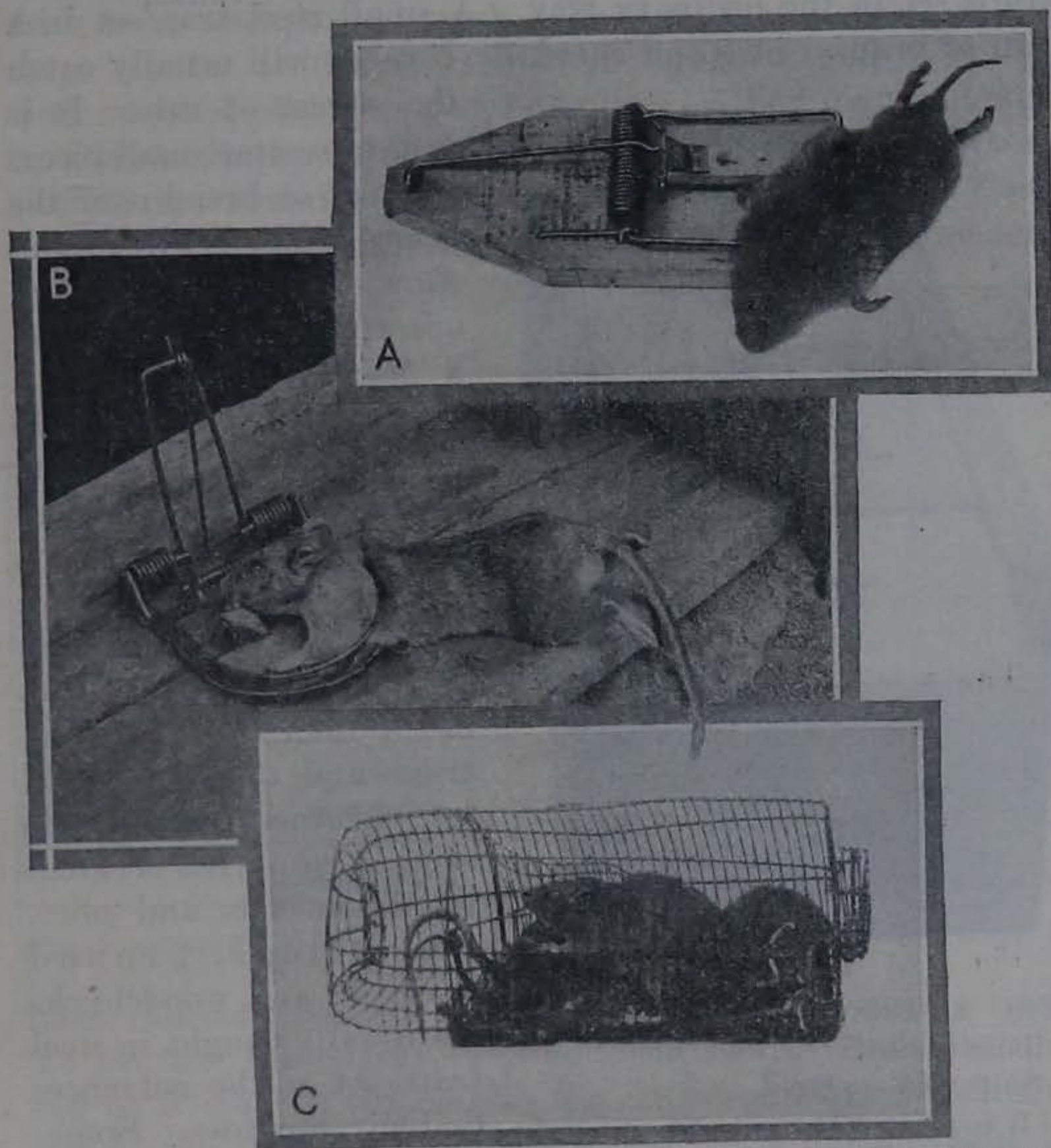

B8926; B58M; B500M

FIG. 1.—Types of Traps Used for Catching Small Rodents.

*A*, Type of trap with wooden base in common use for catching rats and mice; *B*, metal trap for rats, mice, and small squirrels; *C*, wire rat trap. The last operates best when covered with a piece of burlap or with a box having a hole in one end through which rats may pass directly into the trap.

are usually baited with a piece of nut meat, pumpkin seed, or rolled oats, as may be convenient. It is advantageous to use more than one kind of bait at a time, inasmuch as these animals sometimes take one kind of bait in preference to an-

<sup>1</sup> See Farmers' Bulletin 932, "Rodent Pests of the Farm," for further details regarding combating some of these rodents.

other. House mice have a habit of following the walls of a room as they run about, and a trap placed behind a table leg or small object where mice naturally run need not be baited. House rats are sometimes wary and difficult to catch in traps set in the ordinary way. A small steel trap set in a pan of bran or oats and carefully covered will usually catch

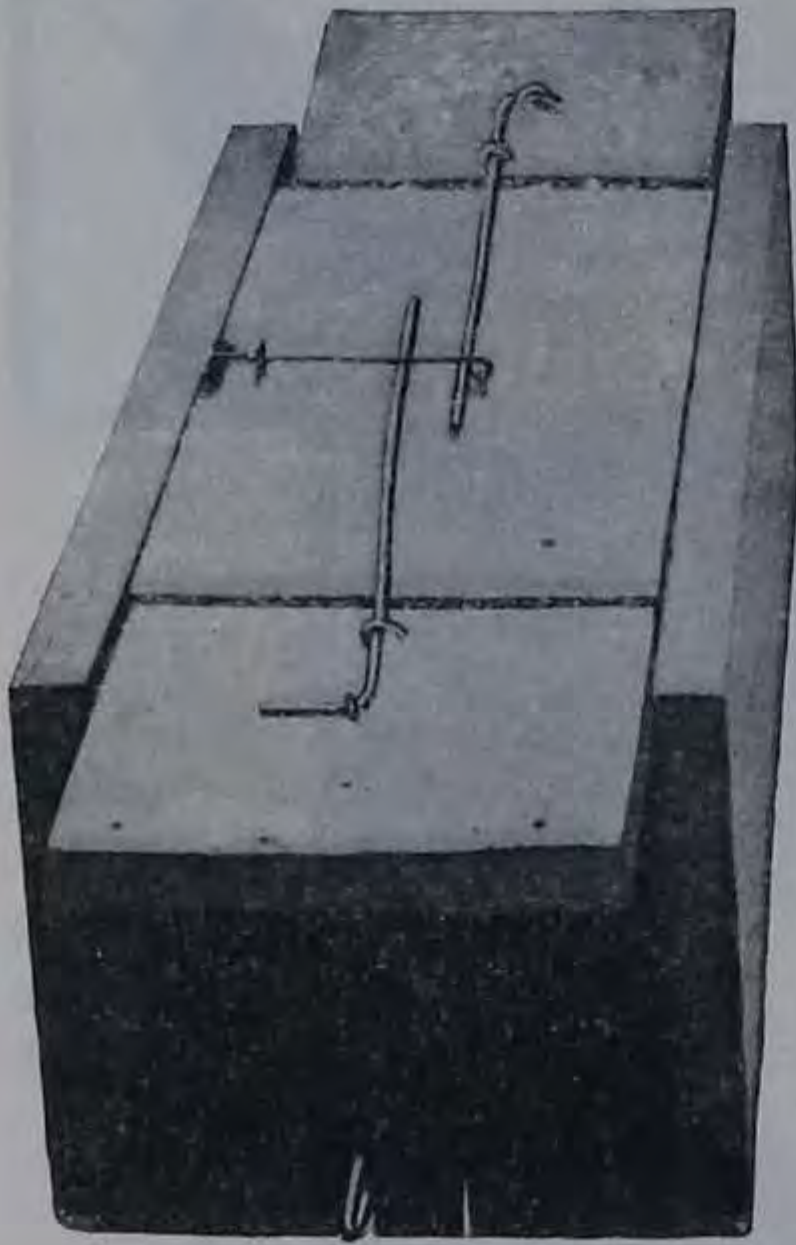

B1260M

FIG. 2.—Box Trap for Catching Rabbits, Squirrels, and Other Small Animals Uninjured.

It may be baited or set without bait in a runway. Details of construction are shown in figure 2.

the shyest of rats. It is well to scatter small pieces of meat or bread over the bran. The wire trap shown in figure 1*C* is more effective when covered by a piece of cloth or by a wooden box having a hole in one end through which rats may pass directly into the trap.<sup>1</sup>

Wild rats and mice may be trapped readily at the entrances to their burrows or in their runways, the traps and the manner of setting them being the same as employed in catching house rats and mice. Prairie dogs, ground squirrels, and woodchucks are usually caught in steel traps set at the entrances to their burrows. Sometimes it is not necessary to cover the traps, but as a rule it is advisable to press them well into the earth and cover them lightly with grass or leaves, or whatever may be at hand. A trap should always be chained to a stake or other firm object so that an animal caught in it can not descend into its burrow or escape with the trap.

Porcupines may be caught by means of an apple, a carrot, or a bit of green corn placed in a crevice behind a No. 2

<sup>1</sup> For full directions for destroying these pests, see Farmers' Bulletin 896, "House Rats and Mice."

or No. 3 uncovered steel trap, as these animals are quite unwary. They may also be caught in traps set at the entrances of their dens, which are often located in cliffs.

Cottontail rabbits are frequently destructive to young fruit trees and garden truck. They may be caught in box traps similar to the one shown in figures 2 and 3, baited with sweet apple, carrot, or pumpkin, or they may be taken in shelter traps, such as illustrated in figure 4. Where rabbits are abundant, shelter traps are occupied by them more or less regularly during the day. A dog trained to

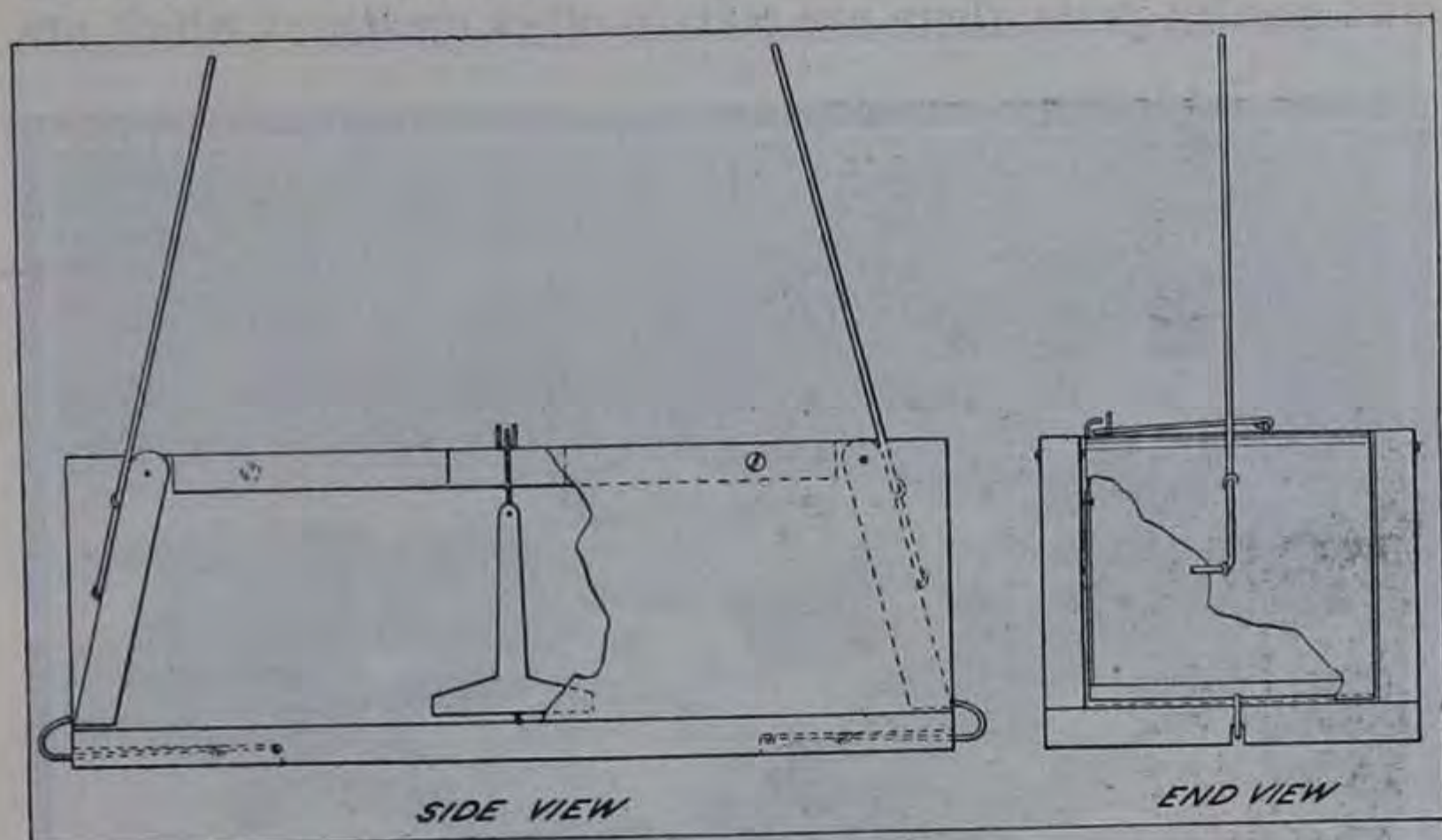

FIG. 3.—Details of Construction of Rabbit Trap Shown in Figure 2.

hunt rabbits will give warning when one is inside a trap. To prevent the quarry's escape a stick with a disk at the end of it may be thrust into the entrance, after which the top of the trap may be opened and the animal caught in the hand. The skins and flesh of trapped rabbits are superior to those of rabbits which have been shot.

In many of the Western States the rodent most destructive and most difficult to capture is the pocket gopher, which spends most of its life underground. Owing to its subterranean habits it has been found expedient to devise special kinds of gopher traps (fig. 5). In making its burrows the gopher throws up on the surface of the ground the dirt it excavates. The trapper, opening a fresh mound, sets a gopher trap well within it and covers the opening behind the trap with a piece of sod, or whatever may be at hand.

It is possible to catch gophers in No. 0 steel traps, but the process is more laborious than that of catching them in the traps specially designed. When steel traps are used, a main burrow is located by prodding with an iron rod, then a piece of turf is removed from it and an excavation made deep enough to allow the trap to be set flush with the bottom of the burrow, after which the piece of sod which was removed is returned to its place. Gopher traps do not require bait.

Besides the rodents, which constitute the majority of farm and garden pests, there are certain other creatures which are



FIG. 4.—Shelter Trap for Catching Cottontail Rabbits.

After a stick having a wooden disk at the end is thrust into entrance, the cover is lifted and the rabbit is captured by hand.

sometimes obnoxious; among these are stray cats, which too often destroy useful birds. The removal of such animals may be effected with neatness and dispatch by means of the trap shown in figure 6, and graphically described in figure 7. One can be made by any ingenious boy at very slight expense. Fresh meat or fish should be used in baiting it.

In many localities one of the worst farm pests is the crow, which is often destructive to grain, eggs, and young chickens. Crows may be caught in steel traps, size No. 1

or No. 2, carefully covered with soil and baited with whatever they are destroying—eggshells, for example.<sup>1</sup>

Such hawks and owls as are destructive may sometimes be caught in small jump traps placed on top of high posts overlooking poultry yards, the trap being fastened securely to the post (fig. 8). As soon as the need of protecting chickens or other animals has passed, the pole traps should be removed so as to avoid risk of killing other birds.

Another pest is the English sparrow, which destroys no small amount of grain during the ripening period. The

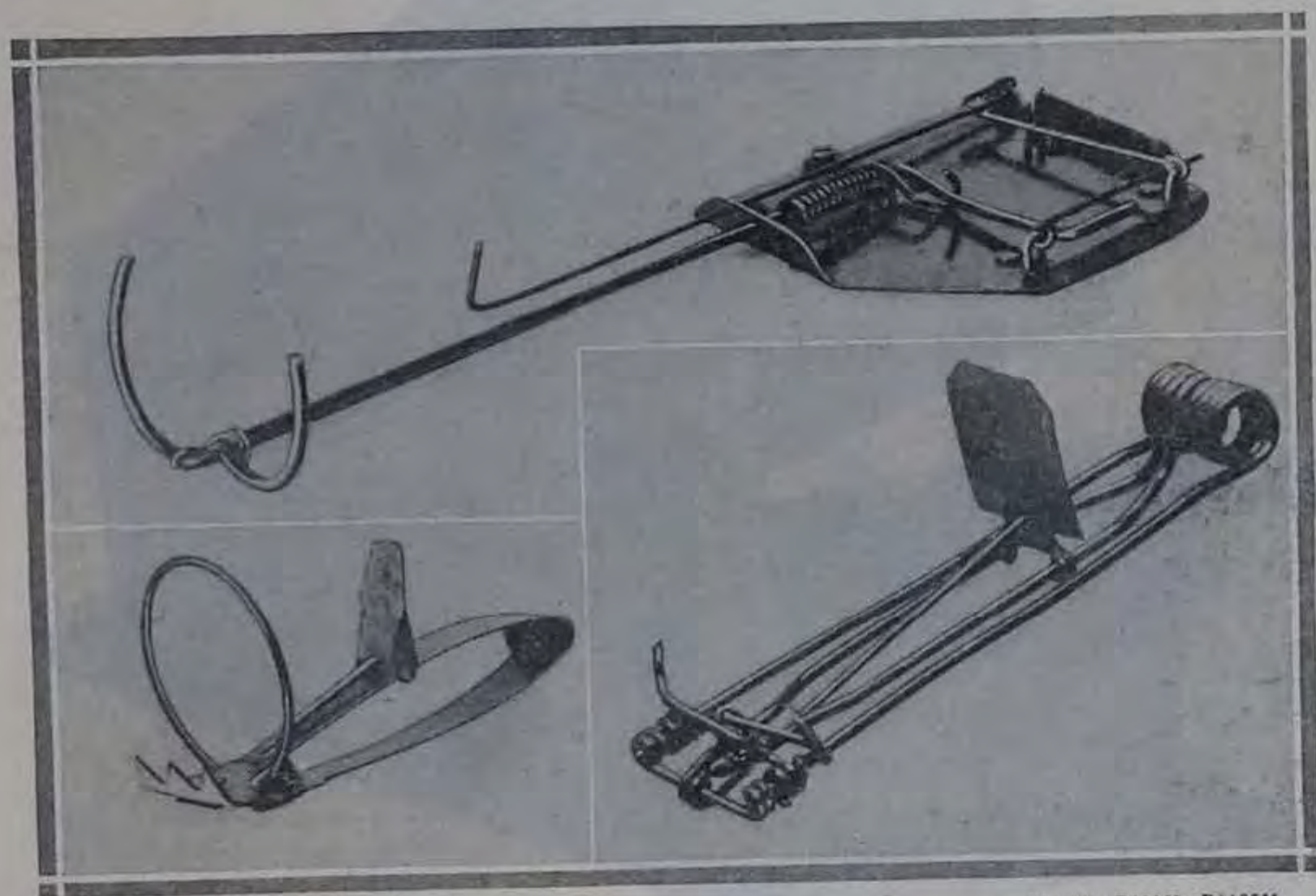

B613M; B611M; B1105M

FIG. 5.—Traps Especially Designed for Catching Pocket Gophers.

traps shown in figures 9 and 10 catch these sparrows very satisfactorily. Rolled oats or crumbs of bread should be scattered around and beneath these traps to attract the birds. In catching sparrows one should be very careful to see that no native birds are destroyed.<sup>2</sup>

#### HOW TO CATCH FUR ANIMALS.

The devices intended for capturing fur animals are numberless, ranging from simple deadfalls (fig. 11A), constructed on the spot out of such convenient materials as saplings and

<sup>1</sup> See Department Bulletin 621, "The Crow and Its Relation to Man."

<sup>2</sup> See Farmers' Bulletin 493, "The English Sparrow as a Pest."

slivers, to patented products of factories. Although certain styles of traps may be used for catching many different kinds of animals, others are used exclusively for a single species having peculiar habits which make ordinary traps ineffective. The assortment of traps here illustrated, while by no means complete, is sufficient for capturing all of the animals included within the limits of this article.

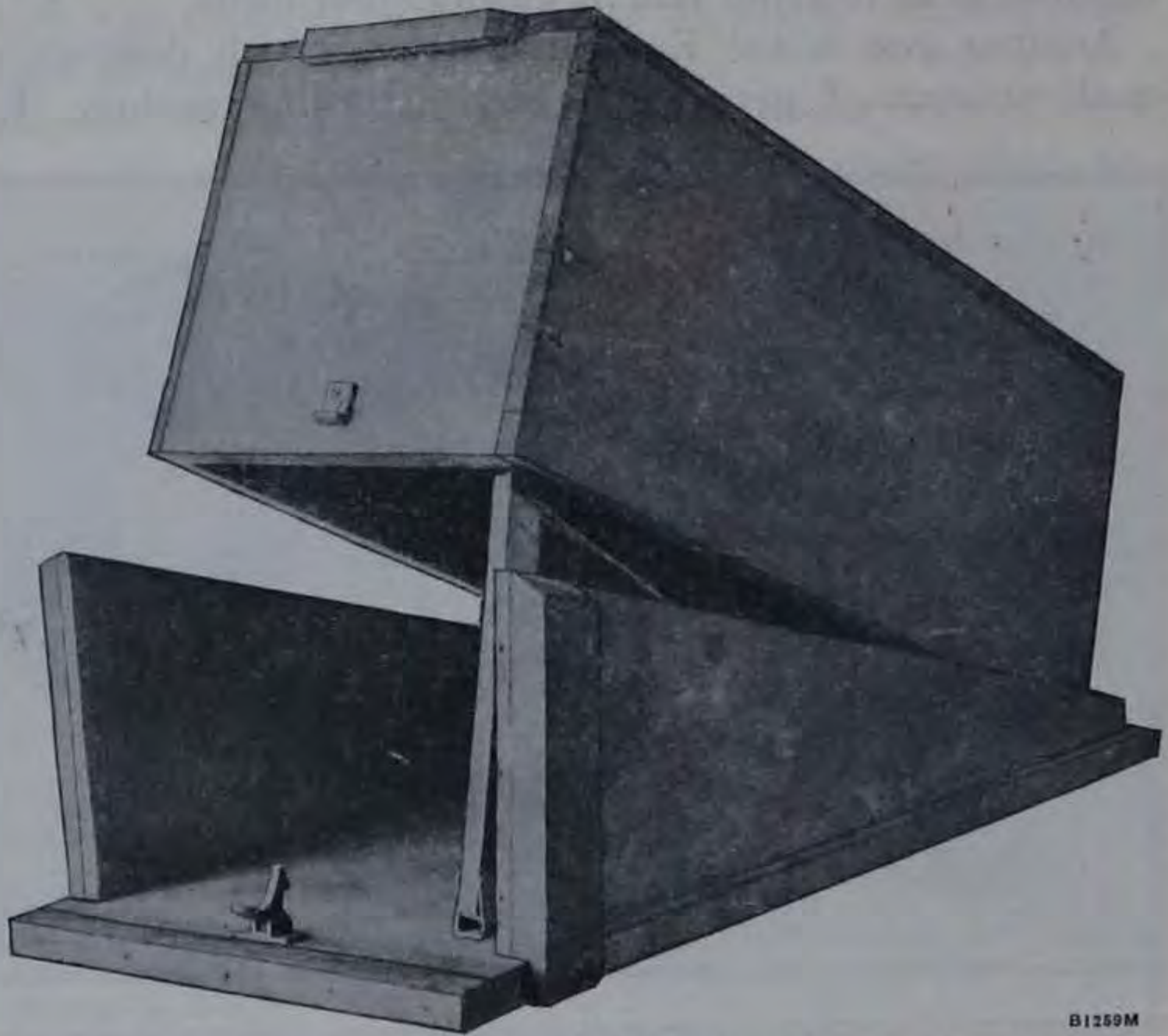

B1259M

FIG. 6.—Cat Trap Designed by the Biological Survey for Catching Vagrant Cats and Disposing of Them Humanely.

Construction and operation are shown in figure 7.

Steel traps (figs. 12 and 13) and other traps likely to be carried away by the animals caught in them are either chained fast to a stake or other immovable object or attached to a grapple or clog which yields when the captured animals make their first frantic efforts to escape, but which can not be dragged far. A sapling makes an excellent drag, the chain being attached 2 or 3 feet from the larger end, which makes it move more or less crosswise and soon become fastened in bushes or weeds. Trap chains should always include a swivel.



In setting a trap a careful trapper always springs it several times to assure himself that it is going to work properly. Before the trapping season opens, steel traps should be cleaned, the joints oiled, and any necessary little repairs made.

## STRIPED SKUNKS.

The striped skunks are found in almost every part of the United States. Sleeping by day in burrows or beneath stones, buildings, or trees, they come forth at night to feed

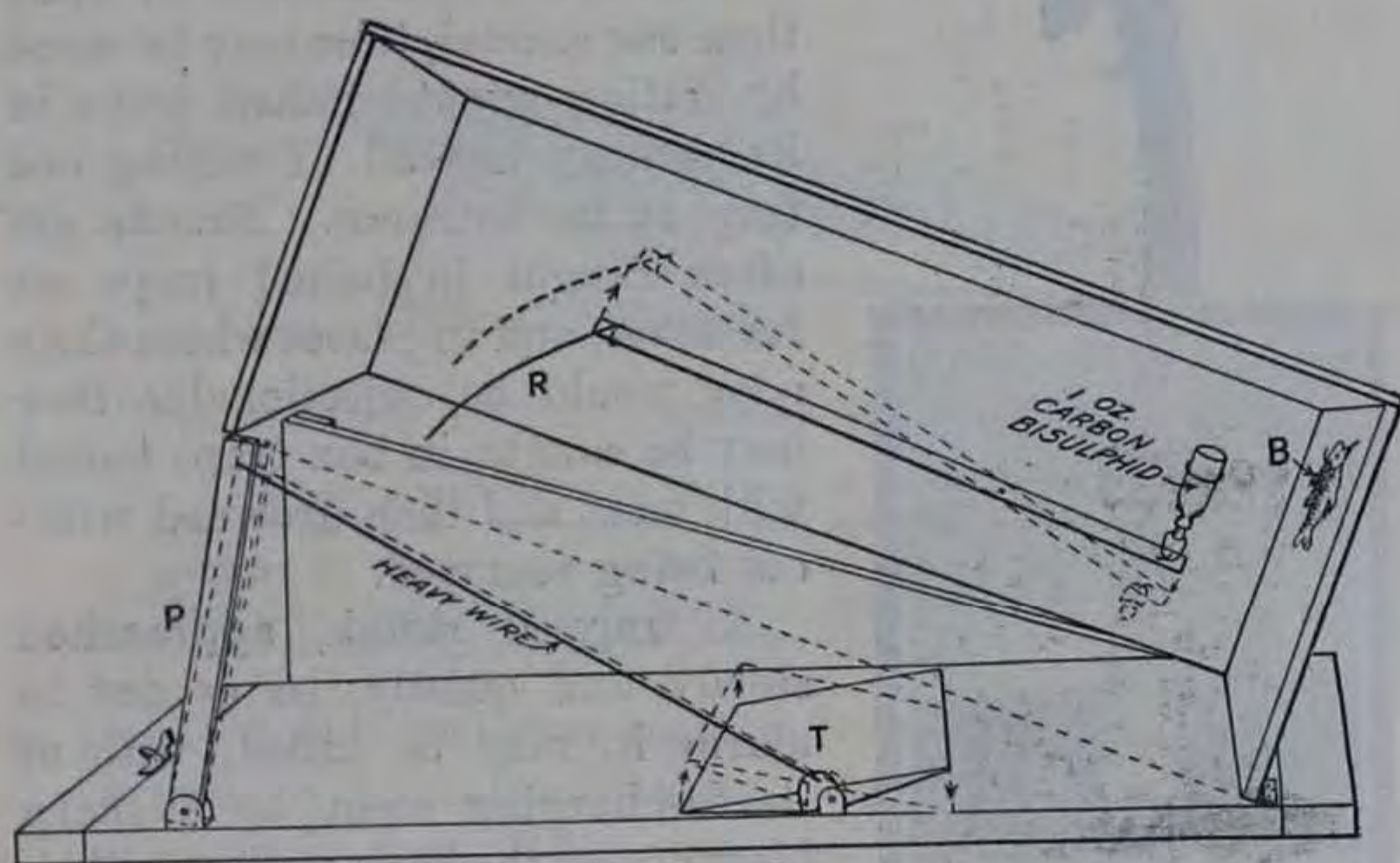

B864M

FIG. 7.—Details of Operation of Cat Trap Shown in Figure 6.

In this illustration the near side of the trap is removed, showing the treadle, *T*, pivoted so as to pull the prop, *P*, under the edge of the box when the box is raised. A cat in reaching for the bait, *B*, tips up the treadle and springs the trap. As the box falls, rod *R*, coming in contact with the cat's back, releases an ounce of carbon bisulphid, which quickly and painlessly asphyxiates the animal.

on insects, small animals, and carrion. Sometimes, but not often, they destroy poultry. Among the signs revealing their presence are numerous shallow pits 1 or 2 inches deep, noticeable in fields and pastures where white grubs are unearthed by these keen-scented animals; these pits are conspicuous late in fall, when repeated frosts have laid vegetation low. The holes the animals occupy are clear of spiders' webs, have a slight skunk odor, and frequently have a few

skunk hairs about the entrance. Their droppings, consisting largely of the hard parts of insects, are readily distinguished from those of other animals of their size.

Skunks are generally caught in No. 1 or No. 2 steel traps set unbaited at the entrances to their dens. The stake to which a trap is fastened should be set the full length of the chain from the hole to enable the trapper to dispatch his catch with as little unpleasantness as possible.

When a den is inhabited by more than one animal, time may be saved by setting several baited traps in its vicinity instead of setting one trap at its entrance. Skunks are often caught in baited traps set for foxes, and in places where their odor would be objectionable they may be caught in box traps baited with meat and then drowned without being removed.

A trapped skunk, approached slowly and quietly, so as not to alarm it, may be killed, without its discharging scent, by a sharp blow across the back with a stick.

Skunk skins should always be freed from fat and cased flesh side out.<sup>1</sup>

#### SPOTTED SKUNKS.

Little spotted skunks, the skins of which in fur shops are called "civet cat," are decidedly smaller and more graceful than striped



B7714

FIG. S.—A Great Horned Owl Captured in a Small Jump Trap Placed on the Top of a Post.

skunks. They are found in the Southern and Western States. Their habits and signs and the methods of catching them are similar to those relating to the large skunks. The size of steel traps suitable for spotted skunks is No. 1.

<sup>1</sup> See Farmers' Bulletin 587, "The Economic Value of North American Skunks."

## MINKS.

Minks are found throughout the greater part of the United States and Alaska. They do not occur in arid regions, as they are dependent on water and are usually found near streams. They feed on fish, frogs, crawfish, and other small animals and birds. Their tracks in snow or sand along streams indicate their presence. They are usually caught in No. 1 steel traps set in holes in the banks of small streams or in driftwood, a chicken or rabbit head, a fish, or some muskrat meat being placed in the hole beyond

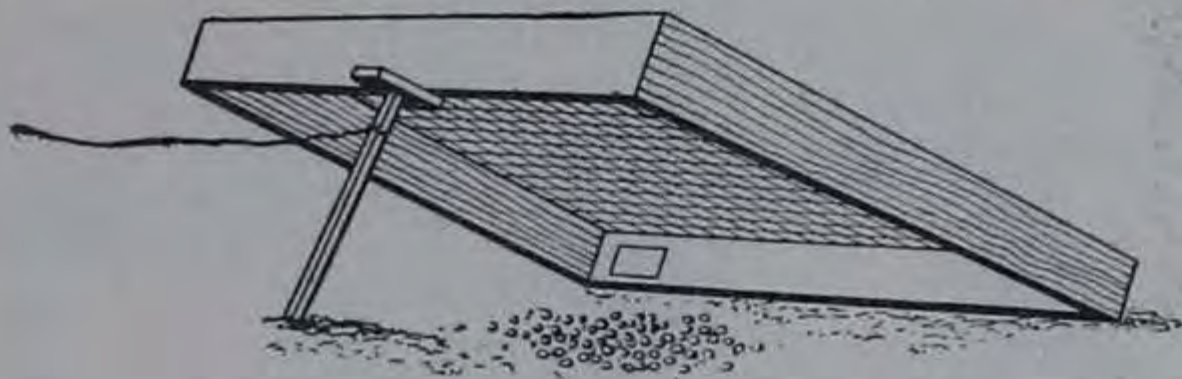

FIG. 9.—Sieve Trap for Catching English Sparrows.

A chip is placed between the end of the prop and the edge of the sieve. When a number of sparrows are congregated on the bait a quick jerk on the line entraps them. They may then be driven through a small door near one corner of the trap into a box or wire cage.

the trap. A bait inclosure may be built of sticks or stones where there is no natural cavity. Another plan is to set a trap about an inch under water on the top of a stake or pile of stones between the abutments of a bridge, or between large boulders or ledges, where it is necessary for minks to swim in following a stream; a fish or meat bait is suspended about 10 inches above the trap.

Mink skins should be cased (see fig. 20) on long, narrow stretchers flesh side out.

## WEASELS.

The large northern weasels, brown in summer and white in winter, are sold in the white dress as "ermine," a name originally applied to a similar animal of the Old World. Only those living in regions having considerable snow turn white in winter, and only the white skins have much value, although brown skins are usually salable at a small price.

The animals roam widely on dry ground, feeding mainly on mice, ground squirrels, and other small mammals and on birds. Owing to a fierce desire to kill far beyond their needs they are sometimes very destructive to poultry; they leave their victims untouched except for a bite in the neck or beneath the wing, and fowls in this condition furnish a sure evidence of their presence. When running the weasel makes two tracks, one a little in advance of the other, its leaps covering 12 to 16 inches of ground. It may be caught in No. 0 or No. 1 traps set under fences, buildings, or fallen

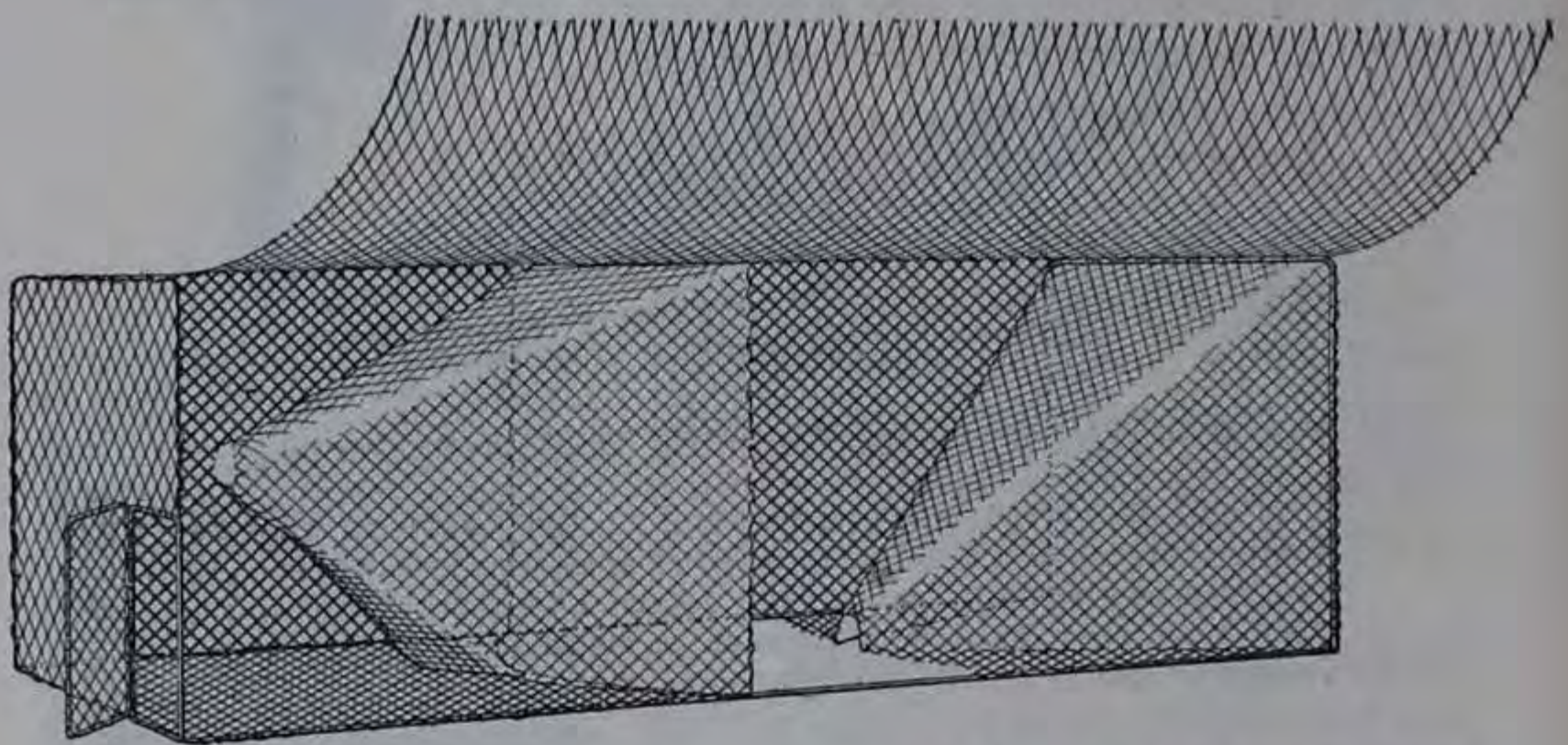

FIG. 10.—Funnel Sparrow Trap, Designed by the Biological Survey.

This is made of  $\frac{3}{4}$ -inch-mesh poultry netting or sand screen, the near side of which, in this illustration, is raised to show the interior.

trees, or wherever it is known to run. A mouse, English sparrow, or chicken head hung 8 or 10 inches above the trap may serve as bait.

Weasel skins should be cased the same as mink skins (see fig. 20).

#### OTTERS.

Otters are comparatively rare animals, but, being extensive travelers, are likely to appear now and then in any of the larger bodies of water, as fish are their natural food. They move about in the daytime and thus may be seen either fishing or at play. In the wilder regions they resort to steep banks of streams, down which they slide in play, plunging into the water below. For catching otters double-

spring No. 3 steel traps are used, set 2 or 3 inches under water at the foot of a slide or where the animals are likely to pass in their fishing.

Otter skins are cased flesh side out.

#### WILDCATS.

Wildcats, known also as bobcats, are found in timbered and mountainous regions, especially where there are cliffs

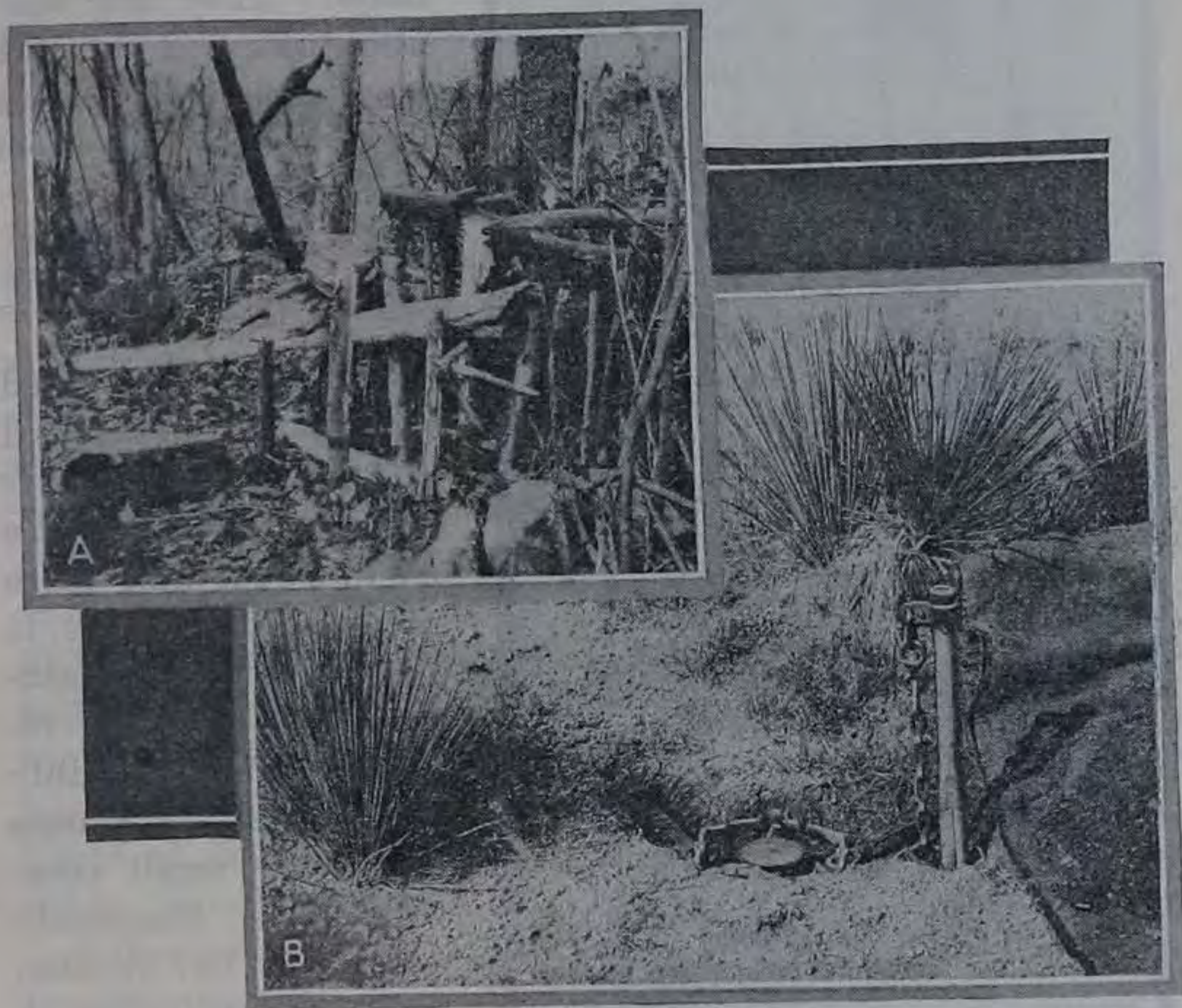

B1262M; B19737

FIG. 11.—Deadfall and Wolf Set.

A, Deadfall made entirely of wood with an ax only; a bottom log, a fall log, four guide posts, one of which has a horizontal branch, a hook, and a pedal stick are the main parts. It is built in front of a bait inclosure. B, Wolf trap bedded for a blind set between yucca plants; any dirt on the canvas not used in covering the trap will be removed and the stake will be driven out of sight.

and broken rock, in which they like to have their dens. They are active by day as well as by night, much the same as house cats. They feed on birds and small animals, and in some localities are destructive to poultry and lambs. Their tracks resemble those of house cats, except that they are much larger.

Wildcats are caught in No. 2 or No. 3 steel traps covered with grass, leaves, or dirt, according to surroundings, and baited with meat, as rabbit or muskrat, fastened about 2 feet above the trap or placed in a crevice behind it.

Wildcat skins should have the feet left on them. They are usually cased flesh side out, although some trappers open them and dry them flat.

CANADA LYNX.

The lynx is confined mainly to Canada and Alaska, but occurs occasionally in the northern and more mountainous States. It lives almost exclusively in timbered regions and feeds mainly on rabbits, but grouse and other small creatures are frequently among its victims. Adapted for living in snowy regions, it has extraordinarily large feet, the tracks of which are easily distinguishable from those of wildcats.

The size of the steel trap generally used for lynxes is No. 3 or No. 4. It may be set, well covered, before an



B1264M; B1257M

FIG. 12.—End-spring Steel Traps are Used Almost Exclusively in Catching the Larger Animals.

In some cases the chain is fastened to a stake, in others it has a clog or grapple at the end.

inclosure baited with meat, or beneath a bait fastened to a tree 3 or 4 feet from the ground, the trap being set about 2 feet from the tree and having brush arranged on either side so as to cause a lynx to pass over it in approaching the bait.

Lynx skins are cased fur side out, special care being taken to preserve the feet.

#### FOXES.

In the United States there are three types of foxes, the red, gray, and kit foxes. Of the three, the red fox, including the color phases known as the cross and silver foxes, is the most difficult to catch and has the most valuable fur. While all these animals subsist mainly on rabbits, ground squirrels, mice, and insects, they are fond also of many kinds of fruit; their droppings usually contain hair and frequently seeds. Their tracks resemble those of a small dog, but are usually slightly narrower, farther apart, and more nearly in a straight line.

Red foxes are keen-scented, suspicious animals and have a wholesome fear of man, so that the trapper must take special care to outwit them. Traps and the ground where they are set must be free from human

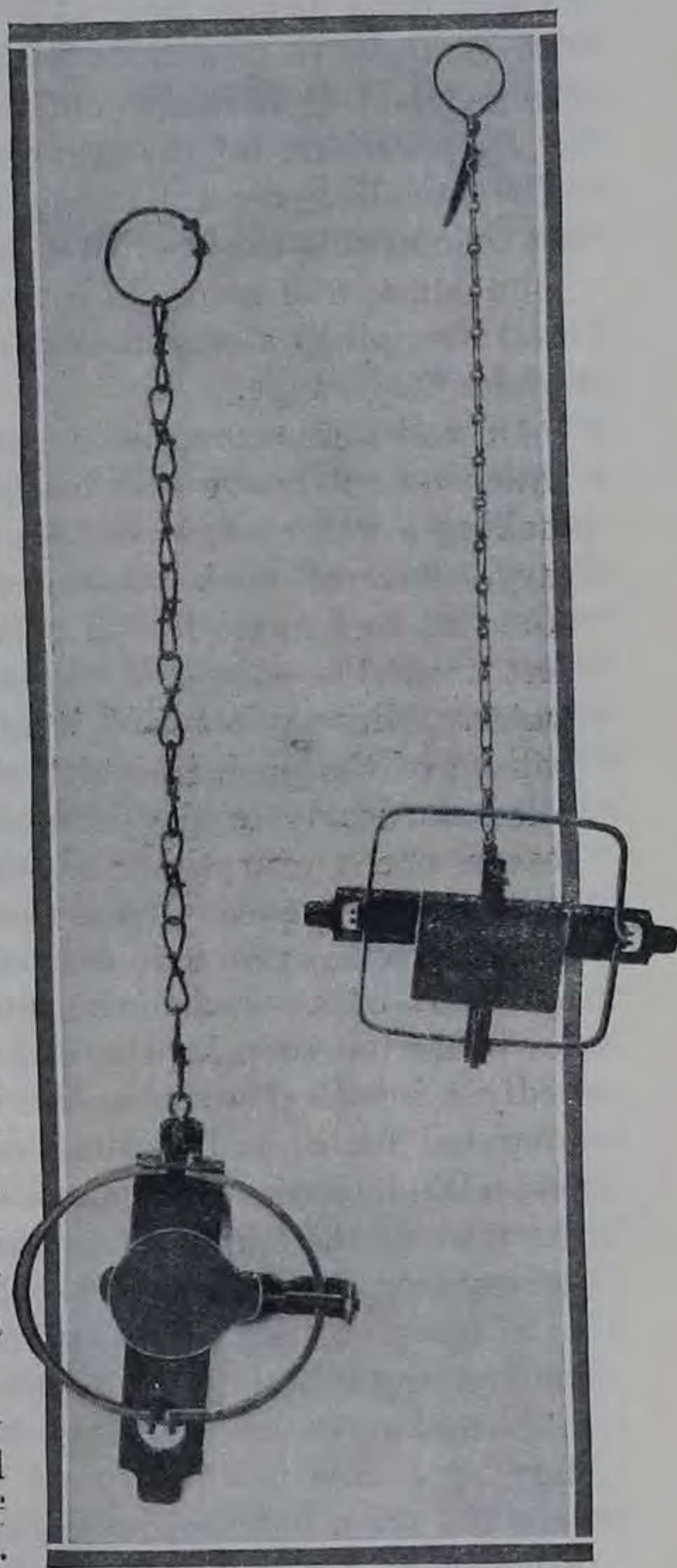

B1257M

FIG. 13.—Single and Double Spring Jump Traps. Largely Used Where End Springs Would be Inconvenient.

odors. Steel traps are cleaned by boiling them with twigs of spruce, fir, hemlock, birch, or sassafras, whichever may be at hand, or by burying them or leaving them in running water for a day or two. After being cleaned they are handled only with leather or waxed cotton gloves and are kept in a clean bag or basket until set.

Preparations for the trapping season go on continuously. The breeding dens, hunting grounds, and peculiar habits of the animals are studied at every opportunity. Tracks in mud, dust, and snow, hair around burrows and on fences, and droppings along unused trails and lumber roads show where they range.

In well-watered regions traps are frequently set in springs which do not freeze over except in very cold weather. For making a water set, a pool not less than 4 feet wide is necessary. Several weeks before the trapping season opens a stone or turf is set in the pool, as a baiting place, about 2 feet from the edge and slightly above the surface of the water. Midway between it and the shore, mud from the bottom of the pool, in which the trap is to be embedded, is piled up nearly to the surface. By the time the trapping season opens everything about the spring has assumed a natural appearance. Then the trapper, walking in the bed of the stream, proceeds to complete his set. He uses as a bait part of a woodchuck, rabbit, muskrat, skunk, cat, or fowl that has been kept out of the way of insects until it is badly tainted. He sets a No. 2 or No. 3 trap in the place prepared for it, and on the pan puts a piece of moss which sets well above the water and covers most of the space within the jaws of the trap. The trap chain is fastened to a stake driven into the bottom of the pool or to a drag, consisting of a stone or pole. The trapper must do all this without leaving any telltale odors on the ground.

In making a land set, the bed for the trap is made by digging a hole in the ground barely large enough to contain the trap, but deep enough for the stake and chain by which it is fastened to be concealed beneath it. The earth removed should be placed on a piece of cloth, and any of it that is not used in covering the trap should be carried away. In placing a trap in its bed care should be taken to have it rest firmly all around so as not to give way under pres-



sure on any part but the pan. To keep dirt from falling beneath the pan and prevent the trap from springing, either a light wad of clean cotton should completely fill the space beneath the pan, or a sheet of thin paper should cover the trap. The trap is covered with dry earth, free from sticks and pebbles, the top layer being like the surrounding surface, making the location of the trap invisible. In winter, to keep them from freezing in, traps are bedded in chaff, dry leaves, or twigs or needles of pine, spruce, or hemlock trees.

Foxes often follow paths or trails, as may be ascertained by observing their tracks, and, taking advantage of this, trappers set traps where a passing fox in stepping over a log or stone will naturally place his foot. The carcass of a horse or other large animal placed near a trail attracts animals that way. They may also be lured by a scent made from trout, eels, or other oily fish left in glass jars a few weeks, or until the flesh has dissolved; the resulting liquid is then covered with a layer of fat which has a strong odor very attractive to carnivorous animals. This scent may be made more effective by the addition of beaver castor or the scent glands from muskrats.

These and similar scents are relied upon to lure foxes to what is known as the blind set (fig. 11*B*), which is made in cleared ground away from trails and water. A field or pasture which foxes are known to traverse is selected and an ordinary land set made there as already described. After a trap has remained bedded for several days and every trace of it has been obliterated, the trapper smears the soles of his shoes with the scent, goes to the trap, and spreads some of the scent on stones, stumps, or grass near it, using a small new paint brush kept in the scent can for the purpose. In looking at traps, and this should be done every morning without fail, they are not to be approached any nearer than is necessary.

Gray and kit foxes are not especially wary. They are readily caught by the methods used in taking red foxes.

Fox skins should always be cased fur side out, the feet and tail being carefully skinned and pinned out to hasten drying.

## WOLVES.

Timber wolves and prairie wolves, or coyotes, are restricted to the Western States. They are so often guilty of destroying domestic animals and deer that they are generally killed whenever possible, and bounties are offered for their scalps in several States. Their presence is made known by their tracks, their doleful howls, and their depredations.

The methods already described for trapping foxes are used for catching wolves. The trapper usually goes on horseback with his trapping outfit, as wolves are not suspicious of horse tracks. Arriving at the place selected for a trail or a blind set, he drops a piece of canvas on which to stand while making the set and is very careful not to step off it or leave anything carrying his odor. Blind sets are often made midway between growths of bushes, yucca, or cactus, 8 or 10 feet apart. A few days after the set has been made the trapper returns and without dismounting from his horse drops some scent among the brush on either side of the trap. The scent may be the one described for catching foxes, or one more attractive to the animals may be prepared as follows:

Put into a bottle the urine from a wolf, the gall, and the anal glands, which are situated under the skin on either side of the vent and resemble small pieces of bluish fat; or, if these can not be readily found, the whole anal parts may be used. In preparing 4 ounces of the mixture use one-quarter the amount of glycerin to give it body and prevent too rapid evaporation, and 1 grain of corrosive sublimate to keep it from spoiling. Let the mixture stand several days, then shake well before using.

Government coyote trappers use with great success what may be called the Bakken prairie-dog set (fig. 14). In a prairie-dog "town" the trapper beds two steel traps about 6 inches apart in the edge of one of the hills and chains them to a stake driven at the mouth of the burrow. A dead prairie dog is placed between the traps and the burrow so as to look as if going into the burrow, and is wired by its head to the stake, the stake, head, and wire being covered with dirt. Beginning near the stake, two shallow trenches are dug, inclosing the prairie dog in an angle to direct a coyote approaching the bait over the traps. In making this set the

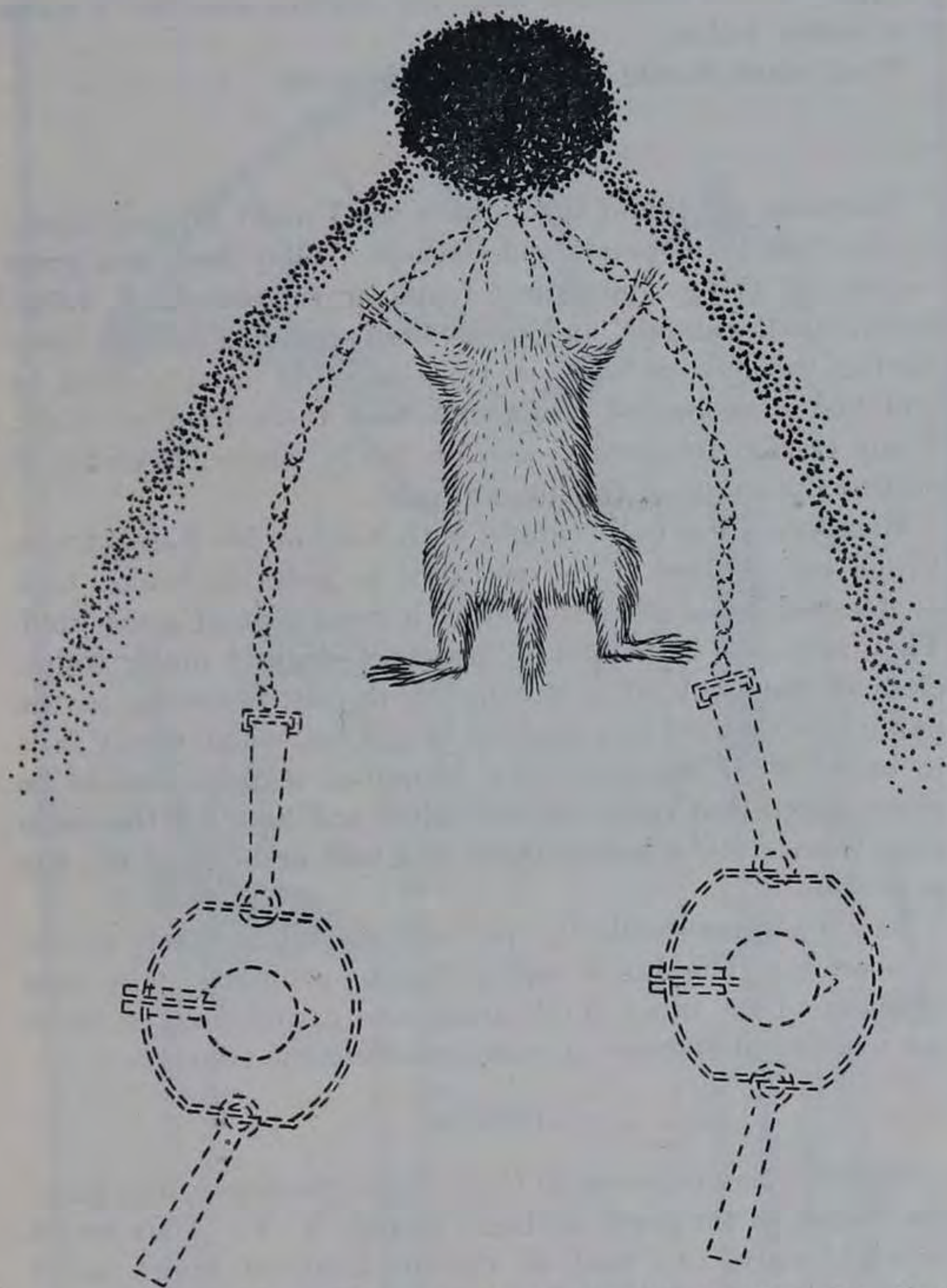

FIG. 14.—Diagram to Illustrate the Bakken Prairie-Dog Set, Used Originally by Government Predatory Animal Trappers in Montana.

Part of a prairie-dog mound is cut away and a stake driven there with a dead prairie dog in front as a bait. A trench is dug on each side, and two traps, chained to the stake, are concealed in the soil just beyond. A coyote will not step over a trench to pick up a prairie dog, but will approach the bait over the smooth surface concealing the traps.

trapper invariably works from the opposite side of the mound. No. 3 traps are used for coyotes and No. 4 traps for timber wolves.

Wolf skins should be cased hair side out.

#### RACCOONS.

Raccoons are found throughout the United States, mainly in the vicinity of ponds and streams. They feed on a great variety of things, including fruits, green corn, fish, frogs, birds, small animals, and occasionally poultry. They sleep during the day in holes in trees or cliffs or supported by crotched branches of trees, and seek their food at night. Their tracks, frequently seen on sandy shores, resemble in outline the shape of the human hand.

Raccoons are usually caught with No. 2 or No. 3 steel traps, which may be set at the entrance to holes in banks, logs, or decayed bases of trees, before a meat bait of some kind. They may also be caught in traps set slightly under water, close to the bank of a stream, by merely fastening to the pan a small mirror or a piece of bright tin, which rarely fails to excite their curiosity. In fastening traps it should be remembered that these animals climb and may lift the chain ring from a stake unless there is a nail or hook at the top to prevent it.

Raccoon skins should be open and shaped as nearly square as possible. The fur is rather thin as compared with that of many of the other fur bearers, and care should be taken not to make it thinner by overstretching the skin.

#### OPOSSUMS.

Opossums are common in the Central, Southern, and Eastern States, as far north as Long Island, N. Y. They travel by night only, and feed on various kinds of fruits, small animals, insects, and carrion. They climb readily and den in hollow trees or logs and in crevices among rocks. Being unsuspecting they are likely to be found anywhere in woodlands, and are easily caught in No. 1 or No. 2 steel traps having meat baits behind or above them.

Pelts of opossums should always be cased flesh side out, the tail and feet being cut off.

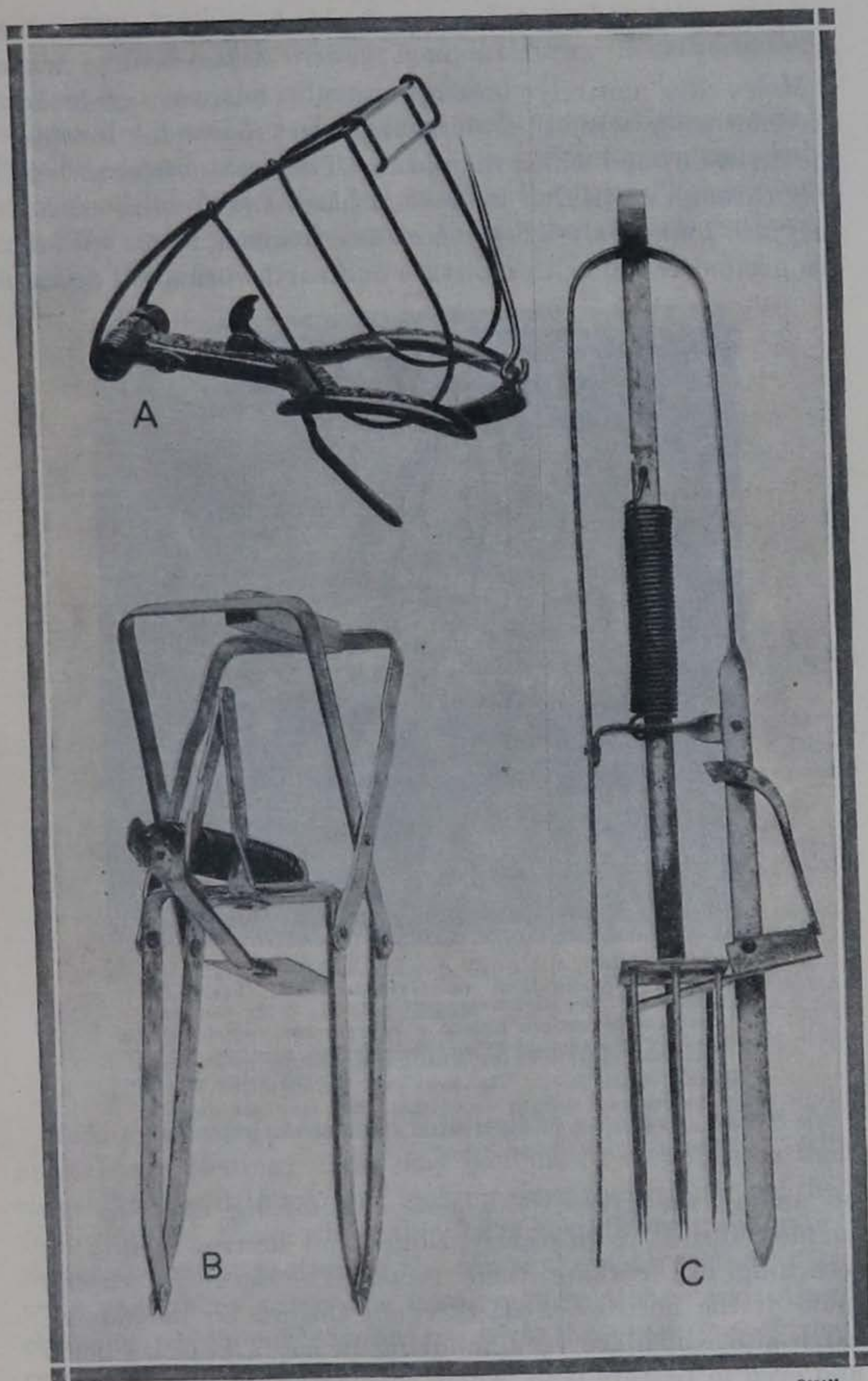

B664M

FIG. 15.—Mole Traps.  
A, Loop trap; B, scissor trap; C, spear trap.

## MOLES.

Moles live entirely underground in burrows made by pressing aside with their large and very powerful forefeet the earth through which they pass. They can not force their way through earth that is dry and hard, and for this reason they are found only where there are frequent rains. When the ground is soft with moisture and earthworms are driven

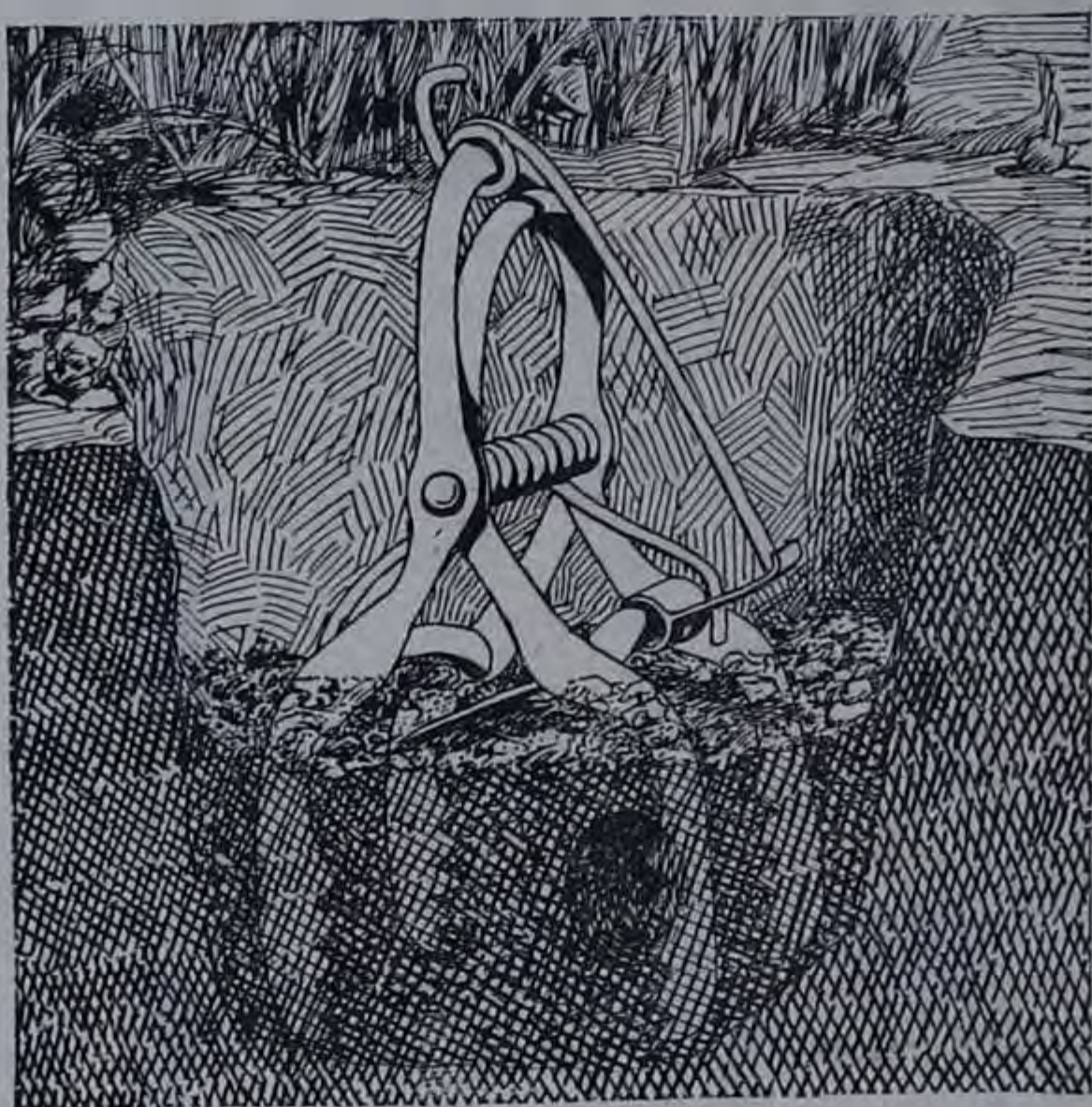

FIG. 16.—Scissor-jaw, or Gripping-jaw, Trap for Moles.

Phantom view, showing position in relation to a deeper runway of the mole. The jaws must straddle the course of the runway and, in order that they may act quickly, the soil must be loosened with a trowel and freed from obstructions, as sticks, stones, or clods.

up among the grass roots, moles, following them to the surface, throw up unsightly ridges and destroy plants by loosening or breaking their roots. The large Townsend mole of the northwest coast region throws up mounds of earth also which are very annoying in hay and grain fields and even in pasture land, where they cover no small amount of grass. Mole hills consist of pellets or balls of earth, and

are readily distinguishable from pocket-gopher hills, which consist of loose earth without compact form. Furthermore, gophers do not make ridges as moles do.

There are a number of kinds of mole traps on the market. Those designed to spear the animals are not recommended when fur is an object, as they damage the pelt. The scissor and loop traps shown in figure 15 kill the animals without injuring their fur.

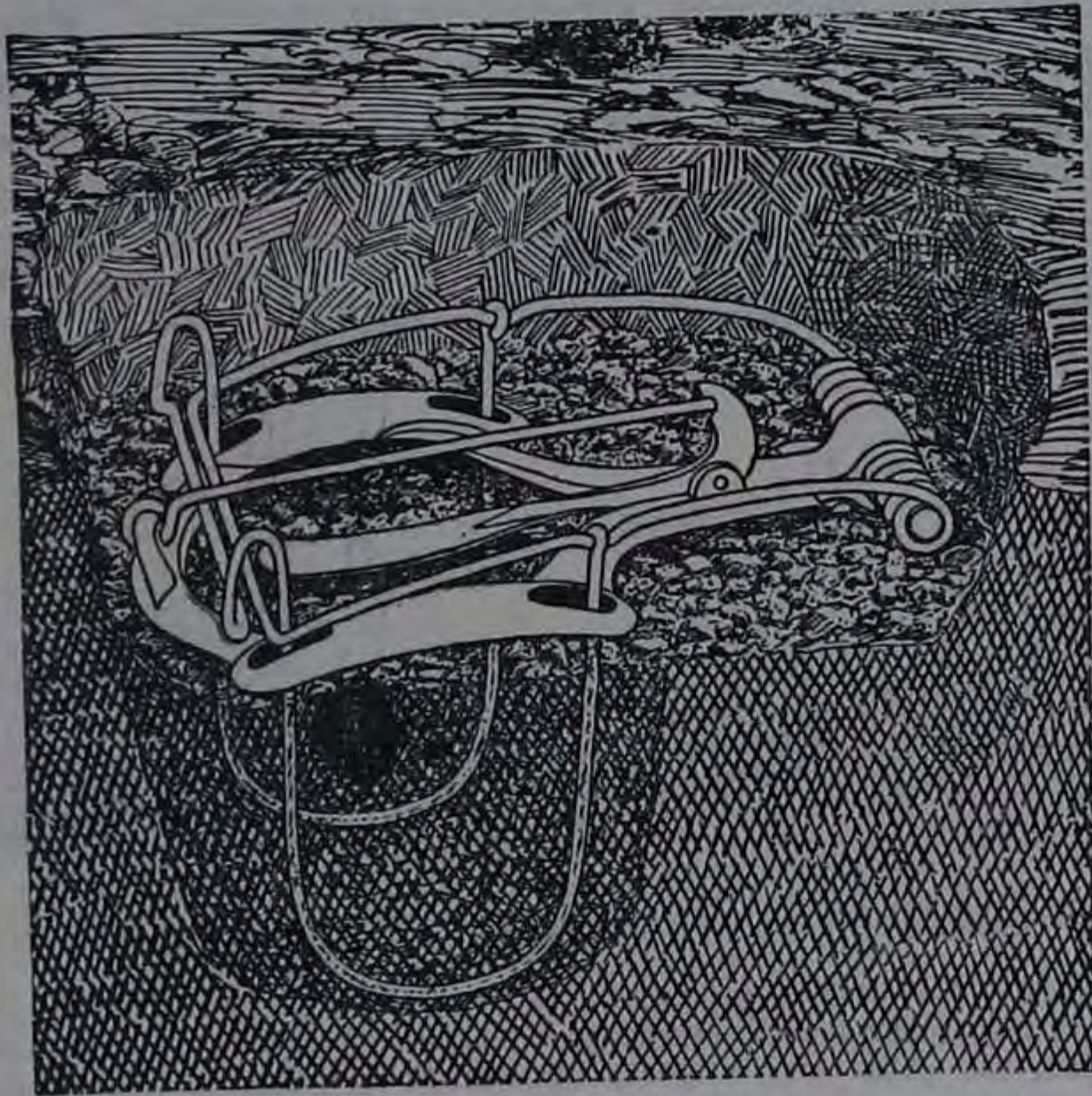

FIG. 17.—Choker-Loop Trap for Moles.

Phantom view, showing trap placed in position on one of the deeper runways of a mole's system of burrows. The loops should encircle the runway through soil loosened to allow quick action.

Before setting a mole trap it is well to ascertain where the animals are feeding. This may be done by stepping on the ridges here and there, and looking over the ground on the following day to see where they have been thrown up again. Select a straight portion of the runway, open a section of it wide enough to admit the trap, remove stones and other obstacles which might interfere with the operation of the trap, and replace enough of the dirt to cover the burrows. Then set the trap as shown in figures 16 and 17 so the jaws

or loops will be well below the burrow, and make sure that the trap will be sprung when the ridge is thrown up again.

Mole skins should be pinned out on boards and dried flat, flesh side up, as shown in figure 18. After the pins have been driven the skin should be raised from the board to allow the fur to stand erect.<sup>1</sup>

#### MUSKRATS.

Muskrats live in ponds, streams, and marshes. Except in waterless areas, the greater part of California, and the coastal regions of several of the Southern States, these ani-

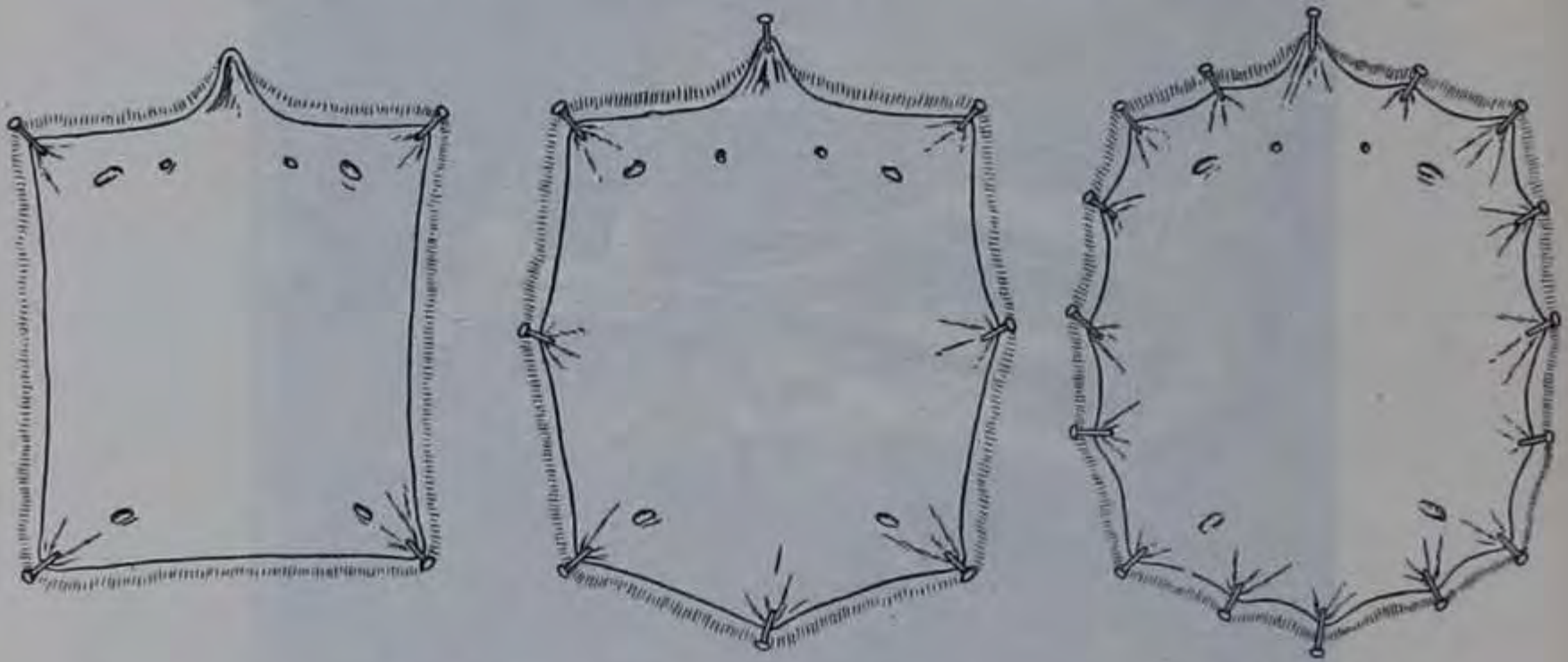

FIG. 18.—Drying Mole Skins on a Board, Showing the Three Stages of Work on One Skin.

(1) Four pins are first used, one in each corner; (2) 4 intermediate pins are then inserted, the skin being slightly stretched; (3) finally 8 more pins are tacked in, one between each two of those already in place.

mals are found practically throughout North America from the northern limit of trees to Mexico. Although occasionally seen in the daytime, they are mainly nocturnal. They eat vegetable food chiefly, as the fruit, foliage, and roots of lilies and other water plants, but frequently vary this kind of diet with mussels and occasionally with fish.

The presence of muskrats is indicated in several ways. In marshes they build conspicuous houses of mud and weeds for winter occupancy. Those living in streams have holes in banks below the surface of the water. In summer they

<sup>1</sup> See Farmers' Bulletins 583, "The Common Mole of Eastern United States," and 832, "Trapping Moles and Utilizing Their Skins."



make paths of clear water through herbage and mud in shallow places, and leave their characteristic droppings on stones and driftwood. Piles of mussel shells and partly eaten roots are evidence that muskrats are living in the vicinity.

The size of steel trap usually set for muskrats is No. 1. As these animals are quite unsuspecting, traps may be set without bait in their paths or at the entrances to their burrows. Bait, consisting of carrots, parsnips, or sweet apples, may, however, be used to advantage, as muskrats are very fond of these foods. The bait may be placed on a bank, or suspended on a stick above the trap, which is generally a little below the surface of the water. Unless a captured

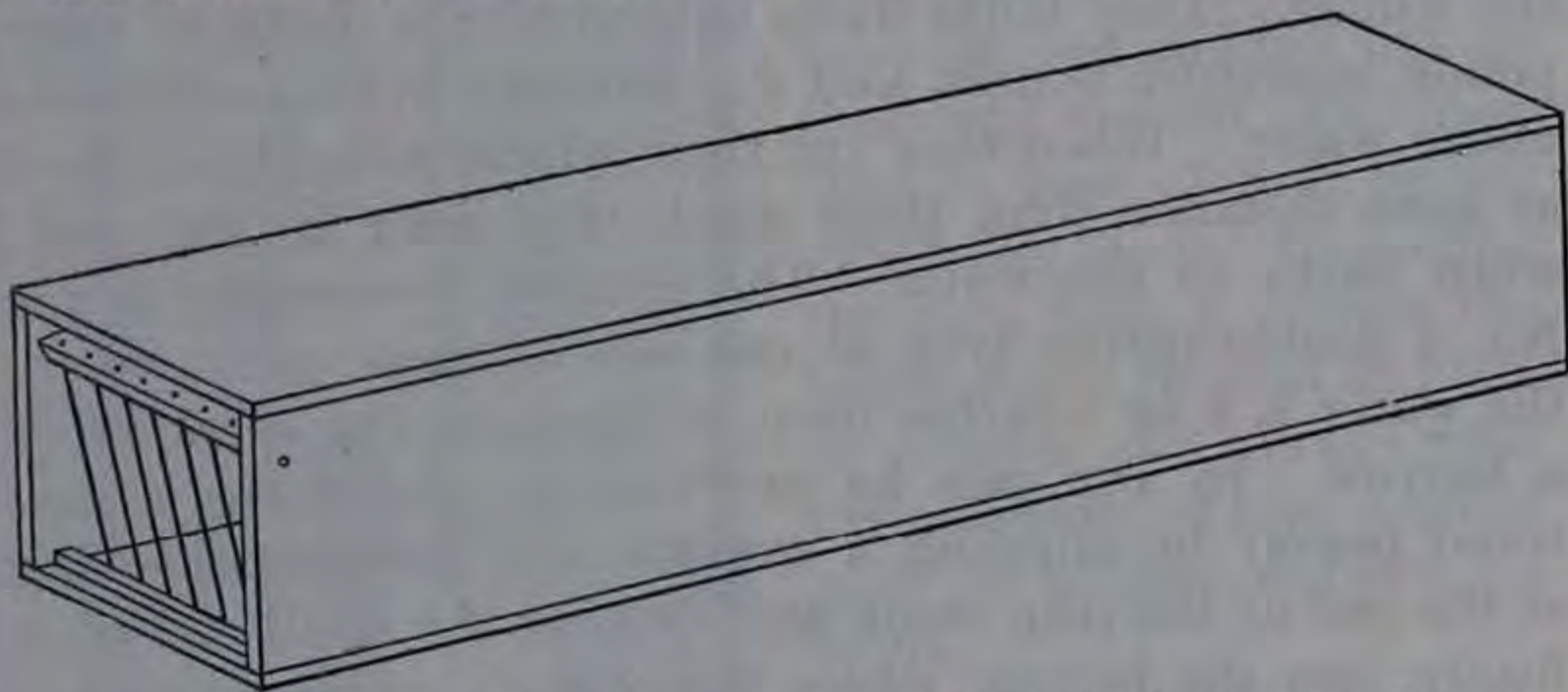

FIG. 19.—Simple Box Trap for Catching Muskrats in Narrow Streams.

The wire doors being hinged at the top stay closed except when muskrats swim against them from the outside. The wires are long enough to prevent the doors from swinging outward.

muskrat can immediately get into deep water and drown, it is likely to twist its leg off above the trap and escape.

The box trap for catching muskrats in narrow streams, shown in figure 19, may be built of four boards, each 8 inches wide and 42 inches long. The ends of this trap are fitted with wire doors hanging by the upper edge. These doors remain closed by their own weight except when pushed open from the outside. A swimming muskrat can enter it easily but can not escape from it. This trap is held slightly under water by a weight of stones, a funnel of sticks or stones being constructed to guide muskrats into it.

A muskrat skin should have the tail and feet removed and be cased flesh side out.<sup>1</sup>

<sup>1</sup> See Farmers' Bulletin 869, "The Muskrat as a Fur Bearer, with Notes on Its Use as Food."

## BEAVERS.

Beavers have been exterminated over a very large portion of the country. They are now well protected by law in most of the States in which they are still found, and their numbers and distribution are gradually increasing. Being very shy creatures and mainly nocturnal, they are rarely seen, but their dams and tree cuttings are unmistakable signs of their presence.

They feed mainly on herbage of various sorts and on the bark of such trees as cottonwood, poplar, maple, and birch, which for winter use they cut into pieces several feet long and carry to their ponds to be peeled under the ice during the winter. They build dams to control the depth of their ponds, construct houses, and dig burrows having entrances under water. When they cut their winter's supply of food at some distance from their pond, they drag it over well-worn paths to the water. The trapper frequently sets a No. 4 double-spring trap at the end of these paths where the water is 4 or 5 inches deep, or again at the entrance of a burrow. In any case he provides for drowning a captured beaver by slipping a smooth pole through the ring at the end of the trap chain and driving the small end of it firmly into the bottom where the water is deep, fastening the large end on the bank above with stakes or heavy stones. On being caught a beaver immediately dives, the ring of the trap chain slides down the pole, and the animal, held under water, soon drowns.

The tail and feet of the beaver are not left on the skin, which is stretched flat and as nearly round as possible. The common way of doing this is to sew or lace it to a hoop somewhat larger than the skin. The long podlike glands known as beaver castor, found just beneath the skin in front of the genital organs in both sexes, are in demand by trappers and raw-fur buyers. After they are removed from the skinned carcass the outlets are tied up to prevent leakage and they are hung up to dry in a cool place. They are used by manufacturers of perfumes and by trappers in making scent baits.

## HOW TO PREPARE SKINS.

The manner of skinning a fur animal depends on whether its pelt is to be dried open or cased. For an open skin the first cut is made from the point of the chin straight to the

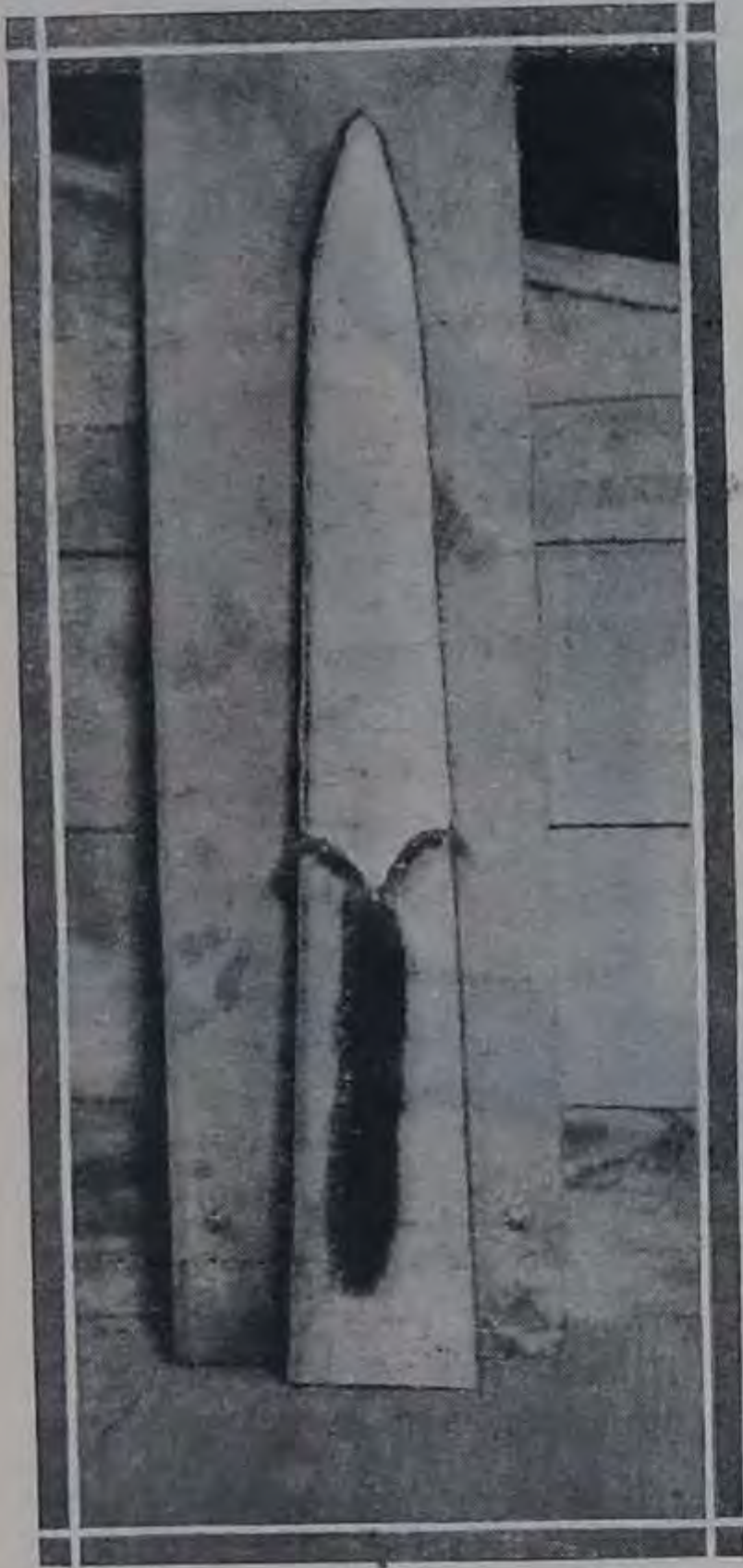

FIG. 20.—Cased Mink Skin on Board Stretcher.

This skin, having no dark spots, is entitled to be called "prime," and to command the top price.

is dressed. After the cuts have been made, the hind legs and feet are skinned out to the toes, the toes and the feet being cut on the under side. At this point it is convenient to hang the carcass by the hamstrings on hooks or pegs. After the tail bone has been taken out, the entire skin is turned from the body very much as a glove is turned from the hand. The fore feet

tip of the tail, along the under side of the body. Side cuts are then made to this from the sole of each foot by the shortest routes. The only exceptions to this rule for taking off open or flat skins occur with beaver and mole skins, which do not have the feet and tail left on them and are cut only from chin to base of tail, no leg cuts being made. In peeling the skin from a carcass the knife should be used as little as possible and always with extreme care, as even a small gash in a skin reduces its value.

For a cased skin (fig. 20), a cut is made from the sole of one hind foot to the sole of the other, on a line running along the rear edge of the hind legs and beneath the tail. The tail is cut along the under side its entire length and the bone is removed. If this is not done the hair of the tail is likely to come out when the skin

are opened from the wrist to the toes and skinned out in the same manner as the hind feet. The ears are cut off beneath the skin close to the skull and the thick cartilage in them is removed. In order to avoid cutting the eyelids, the knife should be carefully applied close to the skull when the first trace of eyes appears as the skin is being turned from the head. Any fat or muscle adhering to a skin should be removed immediately, as fat causes skins to become brittle and worthless, while muscle invites decay when conditions are unfavorable for rapid drying. This is usually done by drawing the skin flesh side out over strips of board or scantling, rounded on the upper side (fig. 21), and by scraping

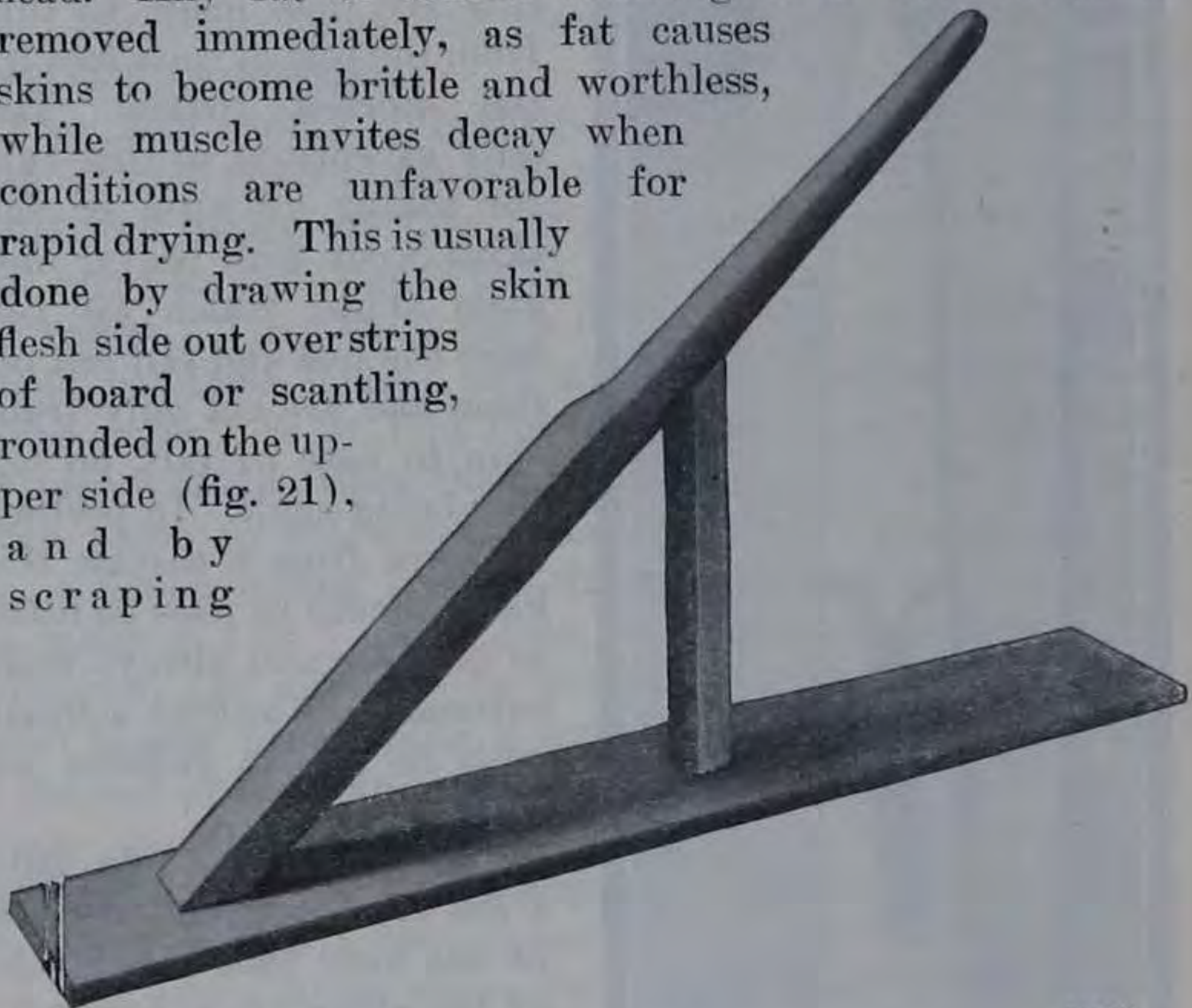

B1260M

FIG. 21.—Fleshing Beam.

Skins are laid on this to be scraped free of fat and muscle, either when they are fresh or after being soaked in cold water until they are soft enough to be worked readily.

it with the back of a knife, a dull file, or the edge of a square stick of hard wood, the scraping always being done from the head toward the tail.

After being scraped, or "fleshed," skins are stretched as uniformly throughout as possible. Open skins are usually pinned or nailed out on any convenient flat surface, flesh side exposed. If such a surface is not at hand, they are sewed or laced to a wooden hoop or frame of suitable size and shape. Cased skins are dried on stretchers made either

of thin board or metal rods shaped so as to stretch them properly in every part (figs. 20, 22, and 23).

Peltries should always be dried in a shady, well-ventilated place, as an open shed, and not by artificial heat when it can be avoided. In regions where the rainfall is excessive and the air is saturated with moisture, it is sometimes necessary to dry skins near a fire.

In packing furs for shipment care should be taken to arrange them so the fur side of one skin will not be soiled by the flesh side of another.

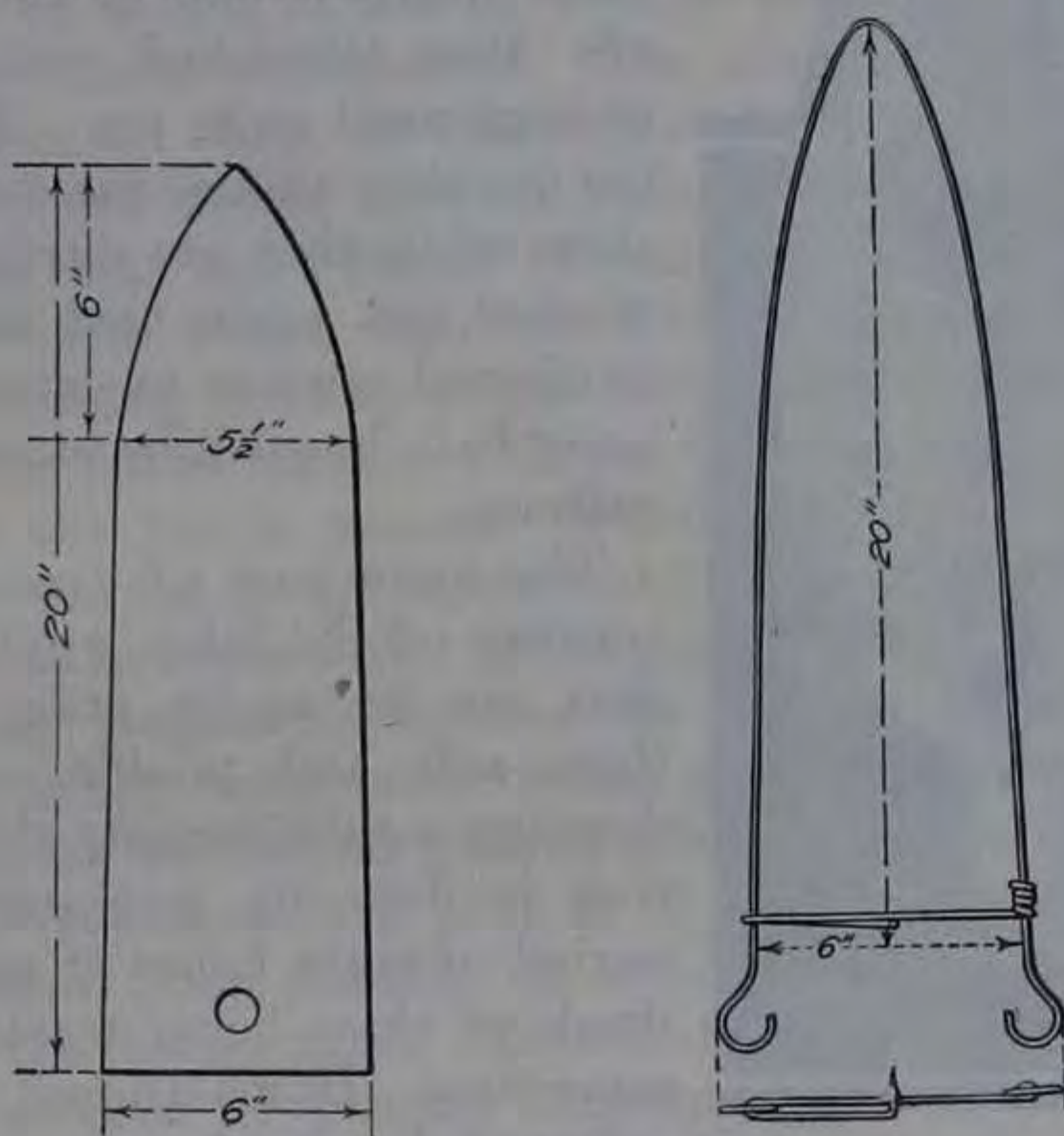

FIG. 22.—Board and Wire Stretchers Designed for Muskrat Skins.

Skins wanted for home use may be dressed by simple though somewhat tedious methods, one of which is here outlined. A tanning liquor is made by adding to each gallon of water one quart of salt and half an ounce of sulphuric acid. This mixture should not be kept in a metal container. Thin skins are tanned by it in one day, but heavy skins must remain in it longer; they may remain in it indefinitely without harm. When removed from this liquor they are washed several times in soapy water, wrung as dry as possible, and rubbed on the flesh side with a cake of hard soap. Flat

skins are then folded in the middle, lengthwise over a clothes line, hair side out, and left to dry. Cased skins are simply hung up by the nose, hair side out. When the hair is barely dry, and the flesh side is still moist, they are laid over a



B1261M

FIG. 23.—Rabbit Skin on Wire Stretcher.

The dark spots on the skin, caused by the development of a new growth of hair, make this skin "unprime" and of considerably less value than if it were fully prime.

spare time it is more satisfactory to send skins to a fur dresser than to dress them at home.

A skin on which the fur is soiled should be cleaned before being stretched. Grease may be removed by a gasoline bath or by hot corn meal or hardwood sawdust rubbed in and shaken out repeatedly and finally beaten out with a

smooth, rounded board and scraped on the flesh side with the edge of a worn flat file or a similar blunt-edged tool. In this way an inner layer is removed, and the skins become nearly white in color. They are then stretched, rubbed, and twisted until quite dry. Fresh butter or other animal fat worked into skins while they are warm and then worked out again next day in dry hardwood sawdust or extracted by a hasty bath in gasoline increases their softness.

The main part of dressing skins consists of the labor applied while they are drying, in order to make them soft and pliable. In skin-dressing establishments this operation is done by machinery for a period of eight hours or more, hundreds of skins being treated at the same time. Home-dressed skins are softened by hand, one at a time. Skins of the same kinds of animals do not always work alike. In some cases it is necessary to return one to the tanning solution once or even twice before it will finally become soft. Unless one has considerable

limber switch. Light-colored furs are stained by blood if it is allowed to remain on them for any length of time. By exercising care the trapper can usually prevent fur from becoming bloody, but when this is impossible the blood should be removed immediately by washing with clear water as long as the water shows a tinge of red. Wet fur should always be dried before the skin is stretched, which can be done by shaking and wiping and applying corn meal or sawdust.

Fur that has been made up into wearing apparel may be freshened by laying it flat on a table and rubbing into it, thoroughly, flake naphthalene. The naphthalene has only to be shaken out when the cleaning is done. Garments that are badly soiled should have the lining removed and be separated into their main parts. These may be washed separately in warm water, with any kind of soap that is suitable for washing woollens, rinsed until clean, and then dried in sunshine where there is a breeze to carry away moisture and keep the fur in motion. When almost dry the parts should be worked in the hands and beaten, after which they are ready to be reassembled in the garment.

Furs are frequently injured by certain insects. Raw skins, especially those more or less greasy, are very attractive to larder beetles and some of their relatives, both in the larval or immature form and in the adult stage. Fur, as distinguished from the skin on which it grows, is eaten by larvæ of the clothes moth. Trouble from both of these pests may be avoided by keeping furs during warm weather in tight tin or sheet-iron cases, and placing in an open dish 1 ounce of carbon bisulphide to each 6 cubic feet of space when the case is finally closed. The gas arising from this liquid when mixed with air makes a violent explosive, for which reason it should never be used in the presence of fire. Dressed furs may be protected from moths by brushing and combing them thoroughly out of doors in bright weather and immediately tying them up in a sack of heavy paper or of closely woven cotton cloth. Raw furs should be either dressed or disposed of before the advent of summer, if possible, to prevent them from being injured by insects or the action of fat.

## HOW TO HAVE MORE AND BETTER FUR.

Reports recently received by the Biological Survey from a large number of raw-fur buyers generally agree that the supply of wild fur has decreased greatly since 1910. In many of these reports the shrinkage is estimated at from 25 to 50 per cent in 10 years. A review of the great fur sales recently held in this country shows that the stock disposed of was brought from all parts of the world to supply the American trade. Manufactured furs in 1919 cost approximately 200 per cent more than the same grade of furs bought two years before, and skins of animals formerly regarded as having little or no fur value were made up into garments selling at from \$100 to \$150 each. All this goes to show that the demand for fur is far greater than can be met. Evidently the time is at hand when steps should be taken to increase and improve the fur supply. Trappers, dealers, manufacturers, and wearers, possessing in the aggregate a tremendous moral and financial influence, want more and better fur.

Among the bad practices which have reduced the number of fur bearers are: (1) Using poison, which kills many animals that are not found before their skins are spoiled; (2) smoking animals out of their dens, which often suffocates them instead of forcing them out; (3) destroying dens, which either leaves the animals without suitable places in which to rear their young or drives them out of the neighborhood altogether; (4) trapping early in fall, which catches animals having small, unprime pelts before they are old enough to be suspicious of traps; and (5) trapping late in spring, which destroys breeding females with young.

If no early or late trapping were done there would be fewer animals taken, but on the other hand the value of the catch and the number of animals left to breed another season would be far greater. Skins are prime for about two months after the molt is completed, and during this time they have no dark spots on the flesh side. They are worth much more when prime (fig. 20) than when unprime (fig. 23). Muskrat and beaver pelts are best in February and March, while those of other fur bearers are best from late in November till about the end of January.



The wild as well as the domestic animals of a farm require food and shelter, and while the farmer is providing as a matter of course for his domestic stock, he will, if wise, be mindful also of the needs of his wild tenants. If he regards his barns as factories for producing milk, meat, and wool, he may as well consider the fox den in the hill pasture and the big hollow sycamore by the creek as fur factories and preserve them accordingly. If he sells only his excess domestic stock, he also will cease trapping the wild "stock" while there are enough fur bearers left on his land to insure another year's fur harvest.

It is as logical to try to make farms produce more fur as to make them produce more beef. The important point is to have people understand the possibilities of increasing their income in this way. When this point is fully appreciated they will uphold State laws which forbid the use of smoke, poison, or other chemicals in taking fur animals, and forbid the destruction of dens and trapping on land of another without written permission. Such laws are already in force in several States, and will undoubtedly be operative in all the fur-producing States in the near future.

The measures thus far considered for increasing and improving the fur output have all been along the line of conservation. Beyond conservation, and surpassing it, are sound constructive measures by which a great and permanent improvement in wild fur may be accomplished. So thoroughly has the animal life of North America been investigated that we know in what region to find the best foxes, the best skunks, the best raccoons, the best muskrats, and the best of every other kind of fur bearer. Nearly all these animals have been bred in confinement, and although only two or three have actually been farmed, there is no reasonable doubt that under favorable conditions all can be propagated on fur farms for distribution on preserves in State and National forests or other public domain, and on private lands set aside by agreement with the owners, where they will be fully protected and from which they will spread when the natural limit to their abundance has been reached.

Just as State game farms raise and distribute game for sportsmen to shoot and State and Federal hatcheries raise

and distribute fish for anglers to hook, so should there be State and Federal fur farms for raising the largest and best-furred animals to be found on the continent for stocking preserves for the benefit of trappers. Possibly here and there a hunter or a poultryman may be inclined to oppose this suggestion, but the hunter may be reassured by the fact that game and fur animals are naturally coexistent and that until steel traps and firearms appeared there was an abundance of both. As to the poultryman's losses due to fur animals they are, in the main, preventable; the price of one fox pelt is sufficient to pay for a good-sized vermin-proof chicken run.

It should not be forgotten that the natural and ordinary food of fur animals consists mainly of materials for which mankind has little or no use, and that certain of these animals render the farmer a positive service by ridding his orchards, fields, and pastures of some of the worst pests infesting them. Generally speaking, therefore, the project to increase and improve fur animals would result in turning useless or harmful organisms into valuable peltries. It would also enable the farmer, when the regular duties of his farm are at their lowest ebb, to reap a self-raised harvest of fur which has cost him nothing and which probably has been developed in his service.

# The HORSE POWER PROBLEM ON THE FARM



By OSCAR A. JUVE,

*Scientific Assistant in Farm Economics, Office of Farm Management.*

## CHOICE OF POWER.

THE CHOICE of sources of farm power depends upon their relative profitableness. To determine which is the more profitable it is necessary to consider many factors, among which are the power requirements of the farm, the size of the power units required, the quality of work accomplished, the displacement of one form of power by the application of another, the total possible utilization of each form of power, the comparative cost of operations with the different forms of power, the relation between the kind of power and the effectiveness of man labor, and the effect upon the profits of the farm as a whole.

The following discussion is based upon the results obtained with horse power on a number of representative farms.

## IMPORTANCE OF COST ACCOUNTING.

Figures 1, 2, and 3 show how accounting records will aid the farmer in securing some of the facts necessary for the proper study of the economical utilization of farm power. These charts are based on cost of production records obtained from the three farms in question.

Figure 1 shows how the work horses were used on a Wisconsin dairy farm. Six horses were used on this farm. The crops grown were about 50 acres of corn, 50 acres of small grain, 30 acres of hay, and 10 acres of tobacco. This combination of crops created a rather uniform demand for horse power during the spring and summer months. During

the winter, however, the horses were idle a great deal of the time, because the work at this time of year was mostly live-stock chores which did not require much horse labor.

Attention is especially called to the time of the year when the various operations were performed and to the amount of horse labor each required. Although most of the field work came during the spring, hay, tobacco, and alfalfa demanded considerable power throughout the summer. The percentage of total horse labor required by each operation is shown by figures on the left side of the chart. These figures are especially helpful in analyzing the amount of horse labor that was done with different-sized teams. Although nearly all the various operations were at times done with two horses, hauling, corn and tobacco planting and cultivating, as well as mowing and raking hay, were regular two-horse operations, while plowing, disking, harrowing, etc., were usually performed with the larger power units. Two-horse operations, therefore, made up about 58 per cent of the total power demand during the year.

Figure 2 shows the horse-labor distribution for an Illinois corn and hog farm, on which there were 108 acres of corn, 56 acres of small grain, and 15 acres of hay. Nine horses were kept on the farm throughout the year.

The grain and corn operations created a heavy demand for horse power during April and May, and the upper bar of the chart shows that the amount of power used at this time was much greater than during any other period. With the "peak load" lasting only about one and one-half months, this farm is in decided contrast to the Wisconsin dairy farm.

Wagon hauling, planting and cultivating corn, mowing and raking, were all two-horse operations in this case, and taken together they make a total of 57 per cent. The other 43 per cent of the work was practically all field operations, for which three and four horses were used, with the exception of the sowing of fall grains between the corn rows with a one-horse seeder.

Figure 3 is based on the records obtained from an Iowa farm on which there were 12 horses and a large tractor. The tractor, however, was a part of the thrashing rig and was not considered a part of the regular farm equipment. In this case the peak load came during the latter part of

## DAILY DISTRIBUTION OF HORSE LABOR BY OPERATIONS (WISCONSIN DAIRY FARM)

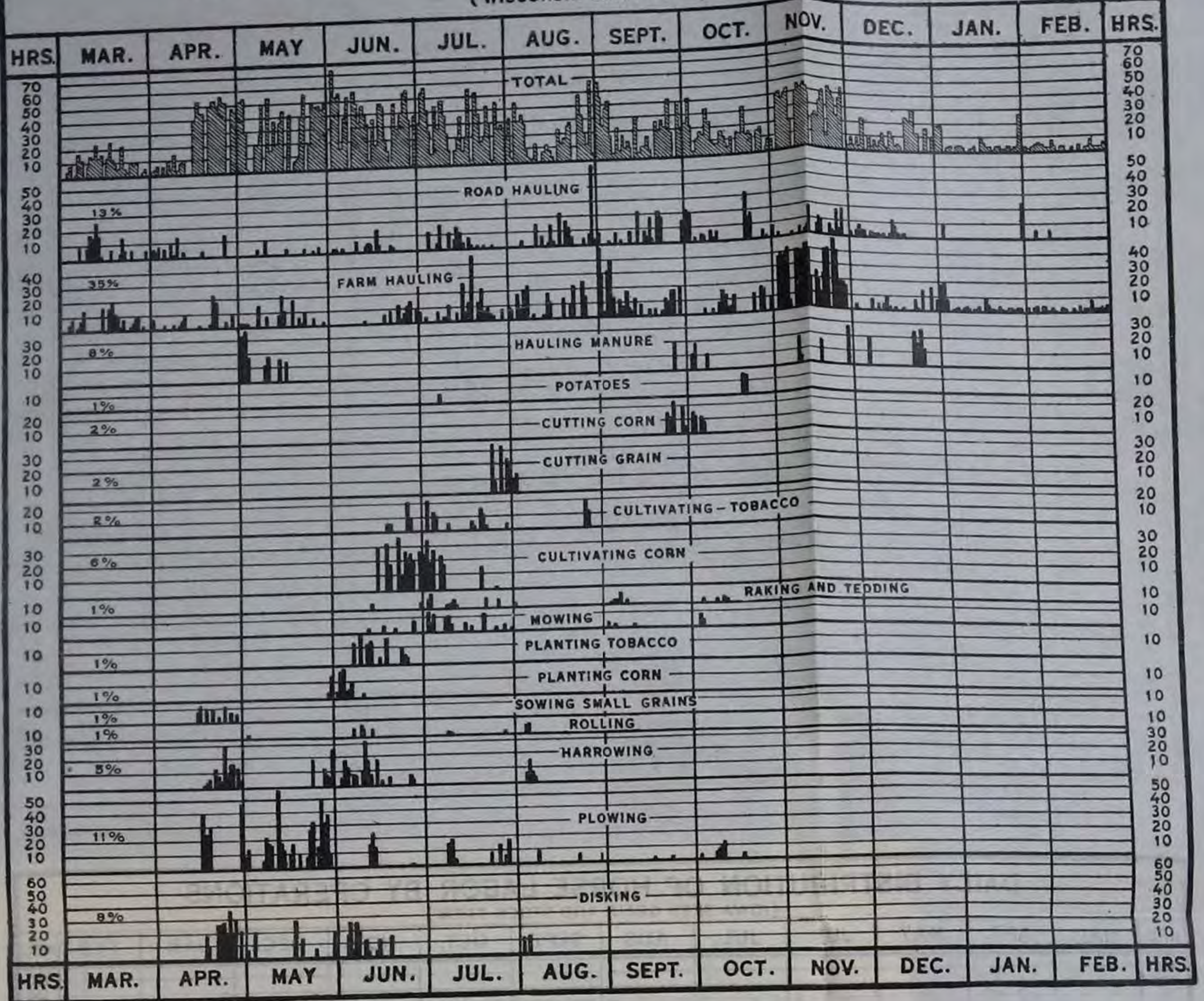

FIG. 1.

## DAILY DISTRIBUTION OF HORSE LABOR BY OPERATIONS (ILLINOIS CORN AND HOG FARM)

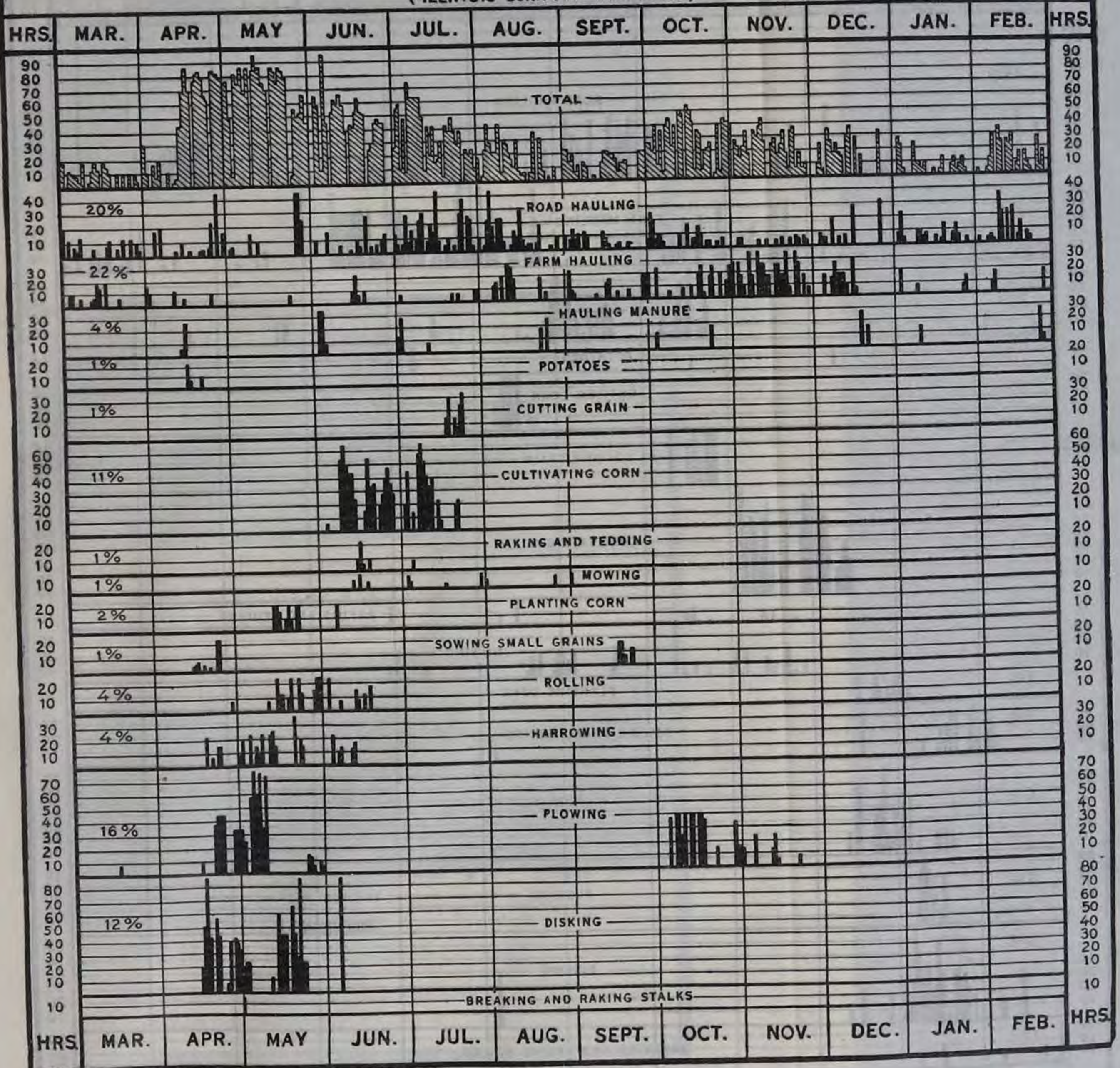

FIG. 2.

How Horse Labor Is Distributed Through the Year.

Figs. 1, 2, and 3 (see other side) show the daily distribution of horse labor on representative farms of three different types, giving the number of hours used for various operations and the total number of hours for all operations.



An Operation in Which Tractor Power May Be Used on Some Farms to Release the Horses for Smaller Power Units to Haul Corn to the Silo.



Half the Work Done by 2-Horse Teams.

power. Practically two-thirds of the 2-horse work on three mid-West farms was wagon work.

ON nine representative farms 50 per cent of the required power was furnished by 2-horse teams. On an Iowa grain-stock farm 2-horse teams furnished 77 per cent of the power, while on a Washington grain farm 2-horse teams furnished only 5 per cent of the

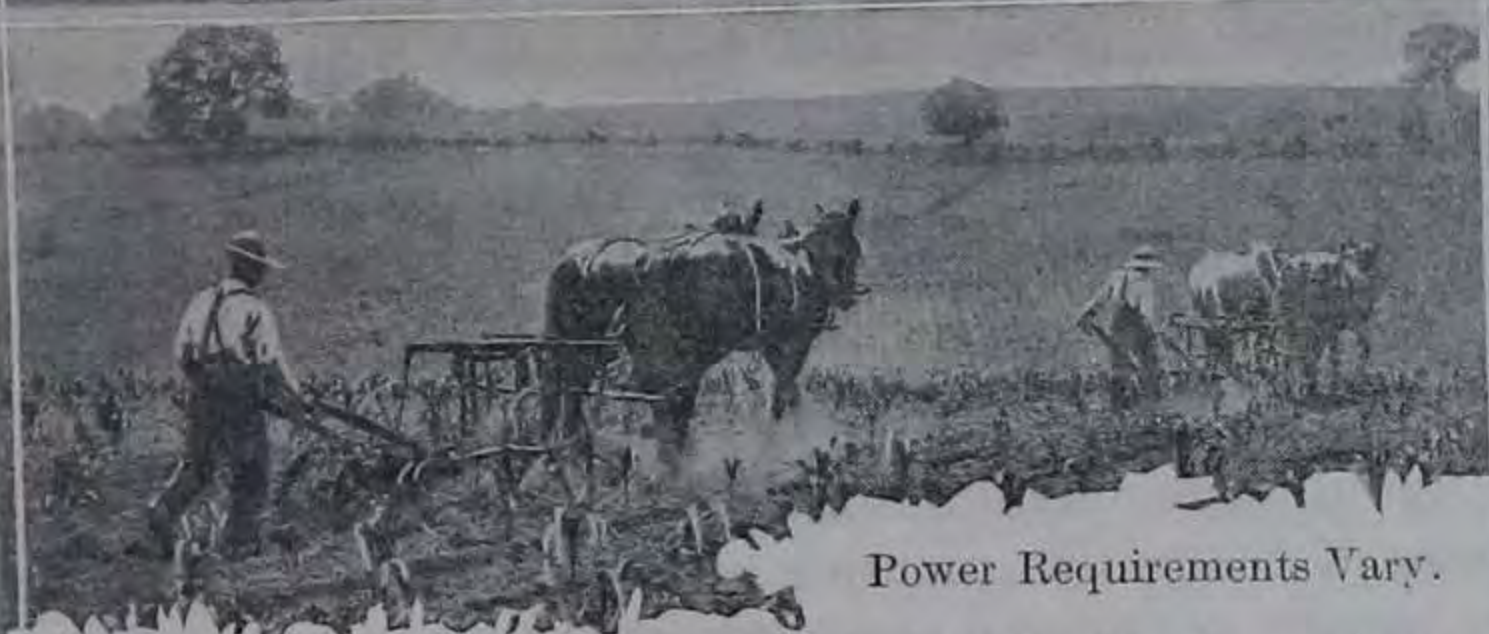

Power Requirements Vary.

WHERE 10 or 12 horses are required to furnish the maximum power for one operation, they can also be divided into independent units for operations like corn cultivating. The tractor may not be suited for both operations.

April and the first part of May and was made up largely of plowing, disking, and harrowing. Corn being the chief, as well as the most profitable, crop, it is not likely that the operator would consider it advisable either to cut down the corn area or to plow part or all of his corn land in the fall. This being the case, there is evidently no way of directly reducing the peak load, and hence his only alternative would be to devise some way of reducing the cost of power. The reason the tractor owned by the operator in question was not used during this period was that previous experience had indicated that it was not suitable for spring work under the prevailing conditions.

While the tractor was not used for field operations in the spring, the chart shows that it was used for all fall plowing, though this work was done at the time when there was little other work for the horses to do.

Attention is called to the proportion of the total horse time required by the various operations. Road hauling (two-horse) consumed 26 per cent of the total time the horses were used, while farm hauling (two-horse) required 21 per cent, making a total of 47 per cent, or almost one-half of the total time. This is a significant fact in the consideration of the choice of power for this farm. The chart shows that corn cultivation, a two-horse operation in this case, demanded 12 per cent of the total time and other two-horse operations consumed 6 per cent more, making a total of 65 per cent of the horse labor performed with a two-horse team.

The percentage of time used in plowing on this farm is affected by the use of an 8-bottom tractor plow in the fall, and is thus smaller than it would be were plowing to be done entirely by horsepower.

#### SIZE OF THE POWER UNITS PER MAN.

Not all farm operations require the same amount of power. Some of them, like planting corn, raking hay, and others, are usually considered one-horse or at most two-horse operations in most sections of the country, while plowing, disking, grain cutting, etc., are coming more and more to be performed with larger power units. This fact, together with the necessity at times of carrying on two or more operations

simultaneously on different parts of the farm, is a very important factor from the standpoint of farm organization, for it makes it necessary that the farm power plant be made up of several independent power units.

Figure 4 gives the percentage distribution of the man time that was used with various-sized power units of nine representative farms in several States. There is a striking similarity in the extent to which two-horse teams were used on all these farms except the dairy farm with 40 crop acres and the larger farms representing extensive types of farming of the Western States. The reason why there was so little two-horse team work on the first farm was that much of the hauling was done with three horses, which fact also explains

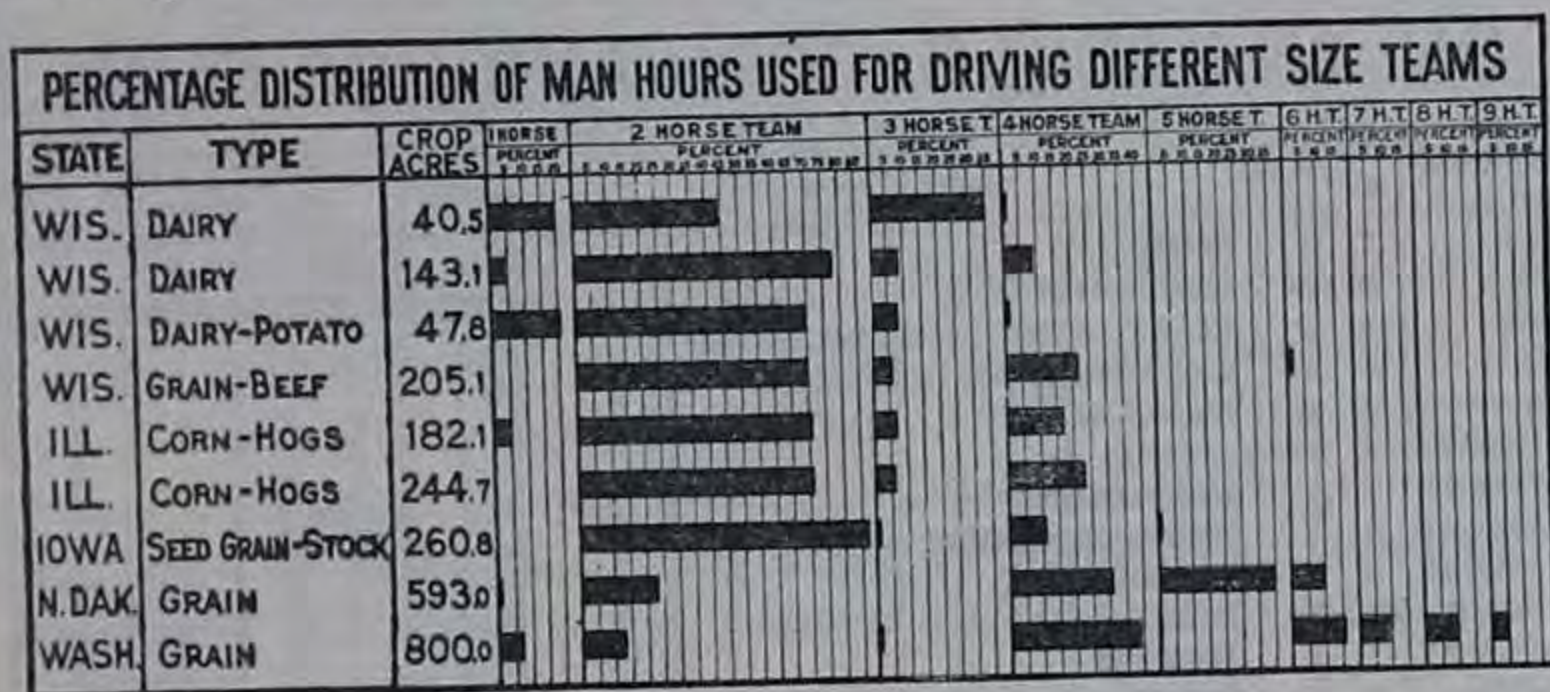

Size of Team Used and Kind of Farm.

FIG. 4.—Percentage of total working time that different-sized teams were used on nine representative farms.

the large number of hours that three horses were used. On the two largest farms there was very little intertilling of crops; the hay acreage was small and large power units were used almost exclusively for all grain-raising operations. This accounts for the relatively small amount of two-horse-team work.

This sort of information is particularly valuable in studying the farm power problems, since it illustrates the power needs in terms of various-sized units. Doubtless further progress will be made in the hitches of farm implements looking toward the practical use of larger horse units as the means of increasing the efficiency of man labor.

Figure 5 gives, by months, the number of hours that different-sized teams were used on the three farms cited above. As has already been indicated (figs. 1, 2, and 3),





most of the farm labor requiring horsepower was done on these farms with two horses, and practically two-thirds of it was wagon work. Figures on this point are important in connection with farm organization studies, for they aid in deciding on the choice between horse and mechanical power. Aside from grain cutting, almost all of the three- and four-horse team work came during the spring months on all of these farms. This is the period when all efficient farm managers usually try to rush the work by making each man handle the largest possible power units. Furthermore, the larger-sized teams usually can be used to better advantage during this time than at any other time of the year.

While these three farms happen to be very similar as to the size of teams used, investigations of this kind indicate that there are large variations in the number of horses used, even for the same operation, in different sections of the country. In some sections farmers very seldom hitch more than two horses to any implement, while in others the reverse is true, namely, that three-, four-, and six-horse teams are used for all operations other than hauling. This may, of course, be due to the difference in farm type, the lay of the land, size of fields, etc., but often it appears to be simply because of the habit of the farmer and customs of the community.

The map shown in figure 6 shows how the size of team used for plowing varies in the different sections of the United States. The power unit for this operation alone ranges from one horse in the southeastern States to five and over in the Dakotas, Montana, Washington, and California, and each unit is used in large and usually contiguous areas.

#### AVERAGE "HORSE DAY" MISLEADING.

The figures usually quoted from cost of production studies for the average horse workday range from two to four hours per day. Data of this sort have led to much agitation to rid the farm of idle horses, and such agitation has undoubtedly done much good by calling the farmers' attention to the importance of giving this matter serious consideration. Upon closer investigation, however, it has been found that this average is almost meaningless as an index as to whether or not an individual farmer is guilty of keeping more horses

than necessary. One reason why the average is not a fair standard of measurement for comparisons of this kind is that the most profitable combination of enterprises may require a large number of horses for only a short period of the year, under which conditions it is necessary to have enough power to handle the work at this time, even though many of the horses may be idle during the greater part of the year. The average, under these conditions, may, therefore, be exceptionally low and still it may be the best of management to continue this form of organization. Another reason for discrediting the average as a means of measuring

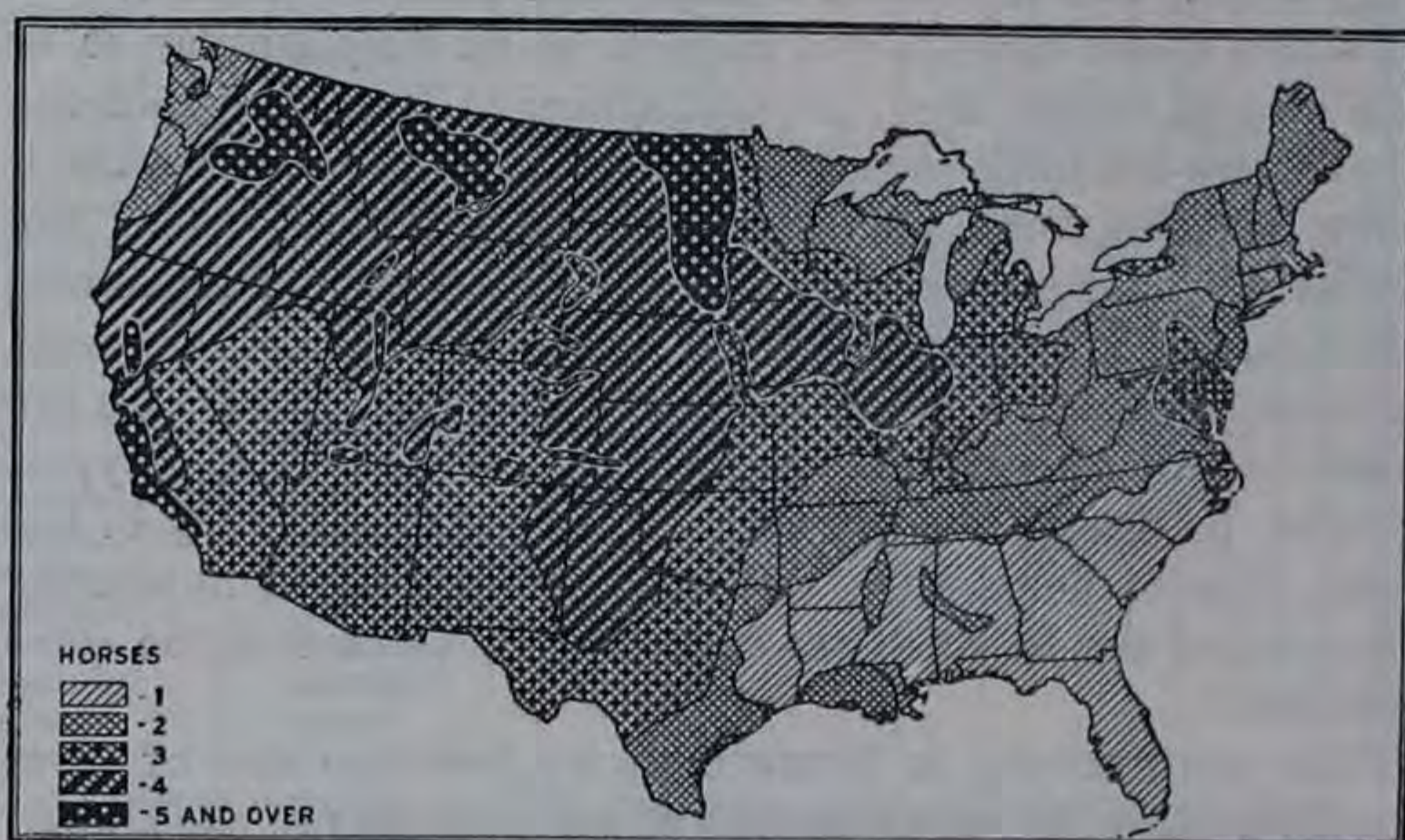

Number of Horses per Power Unit.

FIG. 6.—The United States divided according to sizes of teams ordinarily used for plowing.

the efficiency of power utilization on any given farm is that in power organization it is chiefly a question of combining enterprises that will require all of the available farm power for the largest number of hours.

Figure 7 shows the number of hours the different numbers of horses were used on the same three farms cited in previous charts. From this we can see the number of hours each month that the total available power was required to do the work. Turning to the Wisconsin dairy farms, the demand for a large number of horses is shown to be in April, May, June, and July. During these four months the full number of horses were used 29 days, while they all were used only six and one-half days during the other eight months. The

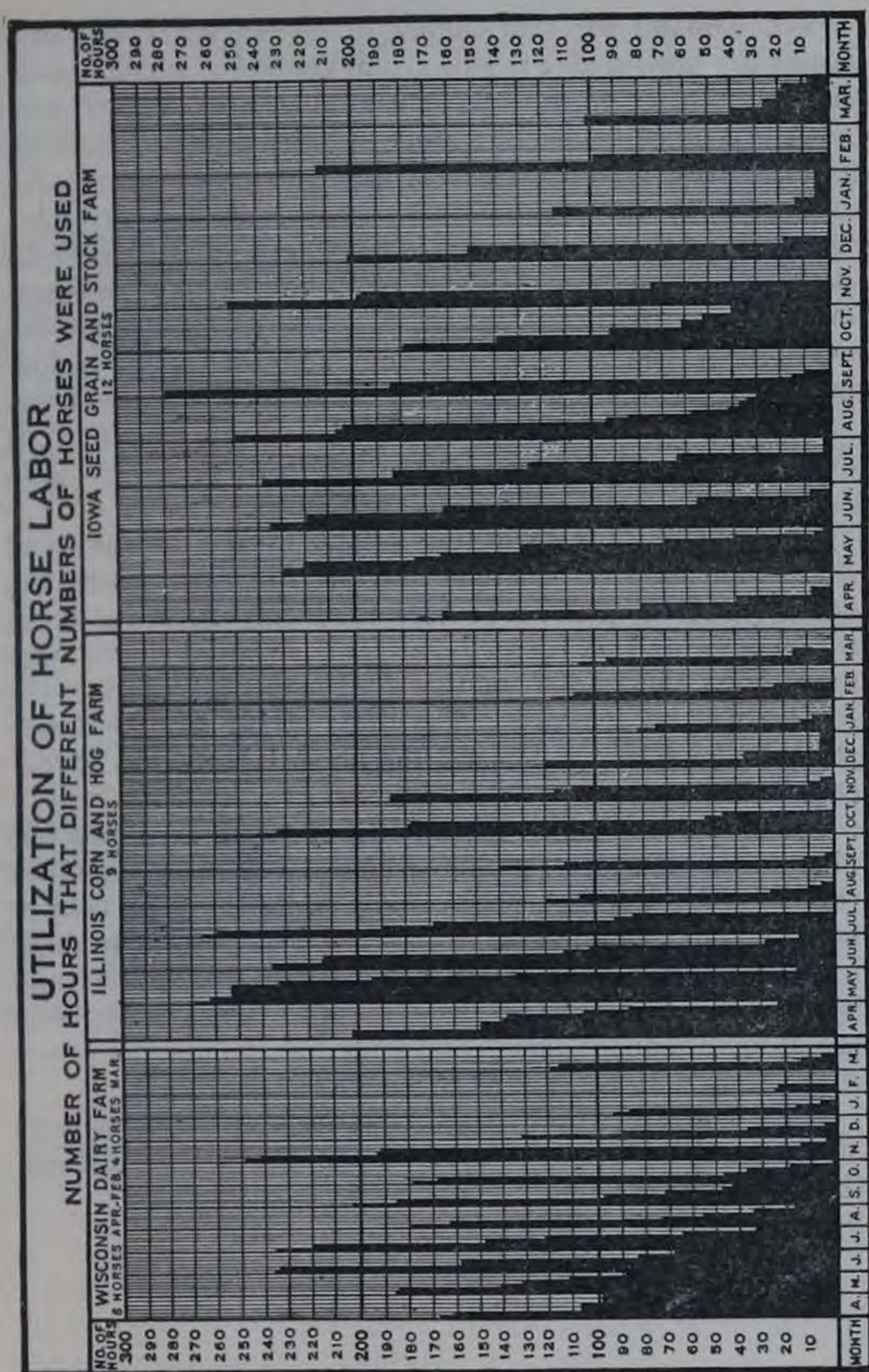

Working Time and Idle Time of Horses on Three Farms.

FIG. 7.—The number of horses on each farm is indicated by the narrow vertical spaces within the month bars, each of which represents a full month's time (10-hour days). The black portions show actual working time of horses, the blank spaces idle time. For example, on the Wisconsin farm during February four horses would have been found idle at any time, five at any time excepting 22 hours and six at any other time excepting an hour or two.

heavy demand for four horses in November was due to using two wagons for husking standing corn, which was an important part of the 71 per cent of the work performed with two-horse teams. In studying this chart the question at once arises: To what extent would it have been possible to spread the work out during the period of heavy labor demand so that four horses might have done the work? April shows ten days of full use of all horses, May nine days, June seven, and July four days. Were it feasible to use, say, four horses more continuously and get the work done satisfactorily, there would be far fewer horses on the farms. *However, the seasonal and weather conditions that limit the hours within which most operations must be performed make such plans in most instances impracticable.*

On the Illinois farm having a total of nine horses all of them were used at one time only six full days during the entire year. Eight horses were used only 20 days, seven for 80 days, and six for 28 days. It is apparent that a large number of the horses on this farm were idle during the greater part of the year. The three spring months, being the period of heavy demand for horse labor, used 53 per cent of the total horse time.

On the Iowa farm the full number of horses were used but nine days. However, purebred mares were maintained on this farm for the raising of colts. While the peak load of horse labor demand came in April and May, as illustrated by figure 3, the greatest use for all horses was in July and September. There was little demand for the simultaneous use of more than six horses and under, as the number above six were used an equivalent of but 40 ten-hour days.

Table 1 presents these data in the form of the percentage of the total horse power used on the above-cited farms in the various-sized units.

TABLE 1.—Percentage of total horse power used in various-sized teams.

Size of team.	Number of horses in team.										
	1	2	3	4	5	6	7	8	9		
	<i>P. ct.</i>	<i>P. ct.</i>	<i>P. ct.</i>	<i>P. ct.</i>	<i>P. ct.</i>	<i>P. ct.</i>	<i>P. ct.</i>	<i>P. ct.</i>	<i>P. ct.</i>	<i>P. ct.</i>	<i>P. ct.</i>
Wisconsin (dairy farm).....	9	41	48	2	.....	.....	.....	.....	.....	.....	100
Wisconsin (dairy farm).....	2	71	11	16	.....	.....	.....	.....	.....	.....	100
Wisconsin (dairy, potato).....	11	74	13	2	.....	.....	.....	.....	.....	.....	100
Wisconsin (grain, beef).....	.....	54	7	34	.....	5	.....	.....	.....	.....	100
Illinois (corn, hogs).....	2	60	9	29	.....	.....	.....	.....	.....	.....	100
Illinois (corn, hogs).....	.....	56	7	37	.....	.....	.....	.....	.....	.....	100
Iowa (seed grain, stock).....	.....	77	1	19	3	.....	.....	.....	.....	.....	100
North Dakota (grain).....	.....	11	.....	31	43	15	.....	.....	.....	.....	100
Washington (grain).....	1	5	1	34	.....	20	13	17	9	.....	100

The above illustrations have been used to call attention to a few of the many important phases of the farm-power problem. They show how horses are being used on farms to furnish the power required. With the introduction of practical types of mechanical power the farmer must face the question of whether he should substitute the tractor for some of his horses. If he decides to introduce the tractor, he must determine what combination of horse and mechanical power will be the most profitable on his farm. To answer these questions accurately requires comprehensive data as to all the facts involved. It is hoped that the material here presented may throw light on the nature of this problem, and suggest some of the factors to be considered in seeking its solution.

## APPENDIX.

### AGRICULTURAL COLLEGES IN THE UNITED STATES.<sup>1</sup>

College instruction in agriculture is given in the colleges and universities receiving the benefits of the acts of Congress of July 2, 1862, August 30, 1890, and March 4, 1907, which are now in operation in all the States and Territories except Alaska. The total number of these institutions is 69, of which 67 maintain courses of instruction in agriculture. In 23 States and Porto Rico the agricultural colleges are departments of the State universities. In 17 States separate institutions having courses in agriculture are maintained for the colored race. All of the agricultural colleges for white persons and several of those for negroes offer four-year courses in agriculture and its related sciences leading to bachelor's degrees, and many provide for graduate study. About 60 of these institutions also provide special, short, or correspondence courses in the different branches of agriculture, including agronomy, horticulture, animal husbandry, poultry raising, cheese making, dairying, sugar making, rural engineering, farm mechanics, and other technical subjects. The agricultural experiment stations, with very few exceptions, are departments of the agricultural colleges. All of the colleges have extension services for conducting cooperative extension work in agriculture and home economics in accordance with the act of Congress of May 8, 1914. With a few exceptions, each of the land-grant colleges offers free tuition to residents of the State in which it is located. In the excepted cases scholarships are open to promising and energetic students, and in all opportunities are found for some to earn part of their expenses by their own labor. The expenses are from \$125 to \$300 for the school year.

#### *Agricultural colleges in the United States.*

State or Territory.	Name of institution.	Location.	President.
Alabama.....	Alabama Polytechnic Institute.....	Auburn.....	C. C. Thach.
	Agricultural School of the Tuskegee Normal and Industrial Institute.	Tuskegee Institute..	R. R. Moton. <sup>2</sup>
	Agricultural and Mechanical College for Negroes.	Normal.....	W. S. Buchanan.
Arizona.....	College of Agriculture of the University of Arizona.	Tucson.....	D. W. Working. <sup>3</sup>
Arkansas.....	College of Agriculture of the University of Arkansas.	Fayetteville.....	Bradford Knapp. <sup>3</sup>
	Branch Normal College.....	Pine Bluff.....	J. G. Ish, jr.
California.....	College of Agriculture of the University of California.	Berkeley.....	T. F. Hunt. <sup>3</sup>
	The State Agricultural College of Colorado.	Fort Collins.....	C. A. Lory.
Connecticut.....	Connecticut Agricultural College.....	Storrs.....	C. L. Beach.
Delaware.....	Delaware College.....	Newark.....	S. C. Mitchell.
	State College for Colored Students.....	Dover.....	W. C. Jason.
Florida.....	College of Agriculture of the University of Florida.	Gainesville.....	P. H. Rolfs. <sup>4</sup>
	Florida Agricultural and Mechanical College for Negroes.	Tallahassee.....	N. B. Young.
Georgia.....	Georgia State College of Agriculture.....	Athens.....	A. M. Soule.
	Georgia State Industrial College.....	Savannah.....	R. R. Wright.
Hawaii.....	College of Hawaii.....	Honolulu.....	A. L. Dean.

<sup>1</sup> Including only institutions established under the land-grant act of July 2, 1862.

<sup>2</sup> Principal.

<sup>3</sup> Dean.

### STATE OFFICIALS IN CHARGE OF AGRICULTURE.

- |  |  |
|--|--|
| Alabama: Commisisoner of Agriculture, Montgomery.                                      | Nebraska: Secretary of State Board of Agriculture, Lincoln.                                |
| Arizona: Dean, College of Agriculture, Tucson.   | Nevada: Dean, College of Agriculture, Reno.  |
| Arkansas: Commissioner of Bureau of Mines, Manufactures, and Agriculture, Little Rock. | New Hampshire: Commissioner of Agriculture, Concord.                                       |
| California: Director of Agriculture, Sacramento.                                       | New Jersey: Secretary of Department of Agriculture, Trenton.                               |
| Colorado: Commissioner, Colorado State Board of Immigration, Denver.                   | New Mexico: President, New Mexico College of Agriculture and Mechanic Arts, State College. |
| Connecticut: Secretary of State Board of Agriculture, Hartford.                        | New York: Commissioner of Agriculture, Albany.   |
| Delaware: Secretary of State Board of Agriculture, Dover.                              | North Carolina: Commissioner of Agriculture, Raleigh.                                      |
| Florida: Commissioner of Agriculture, Tallahassee.                                     | North Dakota: Commissioner of Agriculture and Labor, Bismarck.                             |
| Georgia: Commissioner of Agriculture, Atlanta.   | Ohio: Secretary of Agriculture, Columbus.  |
| Idaho: Commissioner of Agriculture, Boise.   | Oklahoma: Secretary State Board of Agriculture, Oklahoma City.                             |
| Illinois: Director of Department of Agriculture, Springfield.                          | Oregon: President, Oregon Agricultural College, Corvallis.                                 |
| Indiana: Secretary of State Board of Agriculture, Indianapolis.                        | Pennsylvania: Secretary of Agriculture, Harrisburg.  |
| Iowa: Secretary of Department of Agriculture, Des Moines.                              | Rhode Island: Secretary of State Board of Agriculture, Providence.                         |
| Kansas: Secretary of State Board of Agriculture, Topeka.                               | South Carolina: Commissioner of Agriculture, Commerce, and Industries, Columbia.           |
| Kentucky: Commissioner of Agriculture, Frankfort.                                      | South Dakota: Commissioner of Immigration, Pierre.   |
| Louisiana: Commissioner of Agriculture and Immigration, Baton Rouge.                   | Tennessee: Commissioner of Agriculture, Nashville.   |
| Maine: Commissioner of Agriculture, Augusta.   | Texas: Commissioner of Agriculture, Austin.  |
| Maryland: Secretary of State Board of Agriculture, Kensington.                         | Utah: President, Agricultural College of Utah, Logan.                                      |
| Massachusetts: Commissioner of Agriculture, Boston.                                    | Vermont: Commissioner of Agriculture, Montpelier.  |
| Michigan: President, Michigan Agricultural College, East Lansing.                      | Virginia: Commissioner of Agriculture and Immigration, Richmond.                           |
| Minnesota: Commissioner of Agriculture, St. Paul.                                      | Washington: Commissioner of Agriculture, Olympia.  |
| Mississippi: Commissioner of Agriculture and Commerce, Jackson.                        | West Virginia: Commissioner of Agriculture, Charleston.                                    |
| Missouri: Secretary of State Board of Agriculture, Jefferson City.                     | Wisconsin: Commissioner of Agriculture, Madison.   |
| Montana: Commissioner of Agriculture and Publicity, Helena.                            | Wyoming: Commissioner of Immigration, Cheyenne.  |

### STATE OFFICERS IN CHARGE OF COOPERATIVE AGRICULTURAL EXTENSION WORK.

- |  |  |
|--|--|
| Alabama: J. F. Duggar, Alabama Polytechnic Institute, Auburn.                            | Kentucky: T. P. Cooper, College of Agriculture, University of Kentucky, Lexington.                         |
| Arizona: E. P. Taylor, College of Agriculture, University of Arizona, Tucson.            | Louisiana: W. R. Perkins, Louisiana State University and Agricultural and Mechanical College, Baton Rouge. |
| Arkansas: W. C. Lassetter, College of Agriculture, University of Arkansas, Fayetteville. | Maine: L. S. Merrill, College of Agriculture, University of Maine, Orono.                                  |
| California: B. H. Crocheron, College of Agriculture, University of California, Berkeley. | Maryland: T. B. Symons, Maryland State College of Agriculture, College Park.                               |
| Colorado: H. T. French, State Agricultural College of Colorado, Fort Collins.            | Massachusetts: J. D. Willard, Massachusetts Agricultural College, Amherst.                                 |
| Connecticut: H. J. Baker, Connecticut Agricultural College, Storrs.                      | Michigan: R. J. Baldwin, Michigan Agricultural College, East Lansing.                                      |
| Delaware: C. A. McCue, Delaware College, Newark.   | Minnesota: A. D. Wilson, Department of Agriculture, University of Minnesota, University Farm, St. Paul.    |
| Florida: P. H. Rolfs, College of Agriculture, University of Florida, Gainesville.        | Mississippi: R. S. Wilson, Mississippi Agricultural and Mechanical College, Agricultural College.          |
| Georgia: J. Phil Campbell, Georgia State College of Agriculture, Athens.                 | Missouri: A. J. Meyer, College of Agriculture, University of Missouri, Columbia.                           |
| Idaho: L. W. Fluharty, The Statehouse, Boise.  | Montana: F. S. Cooley, Montana State College of Agriculture and Mechanic Arts, Bozeman.                    |
| Illinois: W. F. Handschin, College of Agriculture, University of Illinois, Urbana.       | Nebraska: W. H. Brokaw, College of Agriculture, University of Nebraska, Lincoln.                           |
| Indiana: G. I. Christie, Purdue University, La Fayette.                                  | Nevada: C. A. Norcross, College of Agriculture, University of Nevada, Reno.                                |
| Iowa: R. K. Bliss, Iowa State College of Agriculture and Mechanic Arts, Ames.            |  |
| Kansas: Harry Umberger, Kansas State Agricultural College, Manhattan.                    |  |



- New Hampshire: J. C. Kendall, New Hampshire College of Agriculture and the Mechanic Arts, Durham.
- New Jersey: L. A. Clinton, Rutgers College and the State University of New Jersey, New Brunswick.
- New Mexico: C. F. Monroe, New Mexico College of Agriculture and Mechanic Arts, State College.
- New York: A. R. Mann, New York State College of Agriculture, Ithaca.
- North Carolina: B. W. Kilgore, North Carolina State College of Agriculture and Engineering, West Raleigh.
- North Dakota: G. W. Randlett, North Dakota Agricultural College, Agricultural College.
- Ohio: H. C. Ramsower, College of Agriculture, Ohio State University, Columbus.
- Oklahoma: J. A. Wilson, Oklahoma Agricultural and Mechanical College, Stillwater.
- Oregon: ———, Oregon Agricultural College, Corvallis.
- Pennsylvania: M. S. McDowell, Pennsylvania State College, State College.
- Rhode Island: A. E. Stene, Rhode Island State College, Kingston.
- South Carolina: W. W. Long, Clemson Agricultural College of South Carolina, Clemson College.
- South Dakota: C. Larsen, South Dakota State College, Brookings.
- Tennessee: C. A. Keffer, College of Agriculture, University of Tennessee, Knoxville.
- Texas: T. O. Walton, Agricultural and Mechanical College of Texas, College Station.
- Utah: J. T. Caine, 3d, Agricultural College of Utah, Logan.
- Vermont: Thos. Bradley, University of Vermont and State Agricultural College, Burlington.
- Virginia: J. R. Hutcheson, Virginia Polytechnic Institute, Blacksburg.
- Washington: S. B. Nelson, State College of Washington, Pullman.
- West Virginia: N. T. Frame, College of Agriculture, West Virginia University, Morgantown.
- Wisconsin: K. L. Hatch, College of Agriculture, University of Wisconsin, Madison.
- Wyoming: A. E. Bowman, College of Agriculture, University of Wyoming, Laramie.

## LIVE-STOCK ASSOCIATIONS.

## NATIONAL ASSOCIATIONS.

Name of association.	President.	Address.	Secretary.	Address.
American National Live Stock Association.....	J. B. Kendrick.....	Sheridan, Wyo.....	T. W. Tomlinson.....	515 Cooper Building, Denver, Colo.
National Dairy Union.....	N. P. Hull.....	Lansing, Mich.....	W. T. Creasy.....	Catawissa, Pa.
Southern Cattlemen's Association.....	John D. Eldridge.....	Gregory, Ark.....	R. M. Gow.....	Old State House, Little Rock, Ark.
National Swine Growers' Association.....	Robert J. Evans.....	Chicago, Ill. 817 Exchange.....	W. J. Carmichael.....	37 Van Buren Street W., Chicago.
National Wool Growers' Association.....	F. J. Hagenbarth.....	Spencer, Idaho.....	S. W. McClure.....	Salt Lake City, Utah.
National Mohair Growers' Association.....	U. S. Grant.....	Dallas, Oreg.....	F. O. Landrum.....	Laguna, Tex.

## STATE ASSOCIATIONS.

Alabama Hereford Cattle Breeders' Association.....	J. E. Dunway.....	Orrville, Ala.....	R. J. Goode, jr.....	Gastonburg, Ala.
Southern Alabama Shorthorn Breeders' Association.....	V. D. Smith.....	Eutaw, Ala.....	Morton Crabb.....	Gallion, Ala.
Alabama Shorthorn Breeders' Association.....	F. I. Derby.....	Ward, Ala.....	I. V. Legg.....	Meadow Brook Farm, Eutaw, Ala.
Central Alabama Dairy Association.....	Mrs. Francis Hogan.....	Carter Hill Road, Montgom- ery, Ala.	R. B. Glass.....	Plank Road, Montgomery, Ala.
Arizona Cattle Growers' Association.....	Chas. P. Mullen.....	Skull Valley, Ariz.....	F. E. Schneider.....	Phoenix, Ariz.
Arizona Holstein Breeders' Club.....	J. R. Bradshaw.....	Phoenix, Ariz.....	Frank R. Sanders.....	Phoenix, Ariz.
Northwest Arkansas Shorthorn Breeders' Association.....	Culver Crowder.....	Bentonville, Ark.....	Art. T. Lewis.....	Fayetteville, Ark.
Arkansas Angus Association.....	W. L. Banks.....	Smithdale, Ark.....	R. L. Block.....	Wynne, Ark.
Arizona Wool Growers' Association.....	Hugh E. Campbell.....	Flagstaff, Ariz.....	F. W. Perkins.....	Flagstaff, Ariz.
Arizona Dairymen's Association.....	F. R. Sanders.....	Phoenix, Ariz.....	W. S. Cunningham.....	Tucson, Ariz.
California Swine Breeders' Association.....	C. B. Cunningham.....	Mills, Calif.....	J. I. Thompson.....	University Farm, Davis, Calif.
Pacific Coast Trotting Horse Breeders' Association.....	Dr. H. W. Hand.....	Orland, Calif.....	J. E. Thorp.....	Lockeford, Calif.
	I. L. Borden.....	417 Montgomery St., San Francisco, Calif.	F. W. Kelley.....	Belvedere, Calif.
California Jersey Breeders' Association.....	J. E. Thorp.....	Lockeford, Calif.....	V. C. Bryant.....	Berkeley, Calif.
California Holstein-Friesian Association.....	H. V. Bridgford.....	Patterson, Calif.....	C. L. Hughes.....	211 Ochsner Building, Sacramento, Calif.
Colorado Swine Breeders' Association.....	Carl W. Henry.....	Greeley, Colo.....	Robert B. Broad.....	Fort Collins, Colo.
Colorado Jersey Breeders' Association.....	A. M. McClenahan.....	Greeley, Colo.....	Geo. E. Morton.....	Fort Collins, Colo.
Colorado State Dairymen's Association.....	C. W. Hall.....	Western Holstein Farm, Den- ver, Colo.	Roud McCann.....	605 Chamber of Commerce, Denver, Colo.
Colorado Creamery Butter Manufacturers' Association.....	A. T. McClintock.....	Denver, Colo.....	R. McCann.....	605 Chamber of Commerce, Denver, Colo.
Western Hereford Breeders' Association.....	Dr. T. F. DeWitt.....	Denver, Colo.....	John E. Painter.....	Roggen, Colo.
Colorado Duroc Breeders' Association.....	Judson Solomon.....	Olathe, Colo.....	C. F. Burke.....	Pueblo, Colo (Siloam Star R.).
Western Shorthorn Breeders' Association.....	A. G. Cornforth.....	Elbert, Colo.....	P. D. Warnock.....	Loveland, Colo., R. D. No. 2.
Connecticut Sheep Breeders' Association.....	Henry Dorrance.....	Plainfield, Conn.....	H. L. Garrigus.....	Storrs, Conn.
Eastern Berkshire Congress.....	Lester E. Ortiz.....	Bernardsville, N. Y.....	Richard Lake Faux.....	New London, Conn.
Connecticut State Ayrshire Breeders' Club.....	Wilson H. Lee.....	Orange, Conn.....	Lenard H. Healey.....	North Woodstock, Conn.
New England Devon Breeders' Association.....	John E. Gifford.....	Rockville, Conn.....	Leslie Geer.....	315 Pearl Street, Hartford, Conn.

LIVE-STOCK ASSOCIATIONS—Continued.

STATE ASSOCIATIONS—Continued.

Name of association.	President.	Address.	Secretary.	Address.
Connecticut Guernsey Breeders' Association.....	Rollin S. Woodruff.....	New Haven, Conn.....	Walter Cook.....	Litchfield, Conn.
Connecticut Dairymen's Association.....	Robert Mitchell.....	Southbury, Conn.....	D. J. Minor.....	Bristol, Conn.
Florida State Live Stock Association.....	Dr. W. F. Blackman.....	Lake Monroe, Fla.....	R. W. Storrs.....	De Funiak Springs, Fla.
Stock Growers' Association of Southeast Florida.....	Dr. J. G. DuPuis.....	Lemon City, Fla.....	M. A. Milan.....	Miami, Fla., Box 346.
Georgia Shorthorn Breeders' Association.....	G. T. Stallings.....	Haddock, Ga.....	T. G. Chastain.....	Atlanta, Ga.
Georgia Swine Growers' Association.....	J. F. Jackson.....	Savannah, Ga.....	Tom P. Wootten.....	Tignall, Ga.
	W. H. Peacock.....	Cochran, Ga.....		Milton P. Jarnagin.....
Georgia Dairy and Live Stock Association.....	A. S. Chamblee.....	Bartow, Ga.....	H. P. Redwine.....	Fayetteville, Ga.
Georgia Hereford Cattle Breeders' Association.....	John D. Little.....	Third National Bank Building, Atlanta, Ga.		
Georgia Berkshire Association.....	C. J. Hardman.....	Commerce, Ga.....	Ruohs Pyron.....	Cartersville, Ga.
Northwest Livestock Association.....	Thos. F. Wren.....	Fenn, Idaho.....	O. P. Henderson.....	Lewiston, Idaho.
Idaho State Dairy Association.....	Gustave Kunze.....	Buhl, Idaho.....	F. R. Cammack.....	Boise, Idaho.
Idaho Livestock Association.....	Dean E. J. Iddings.....	Moscow, Idaho.....		
Idaho Cattle and Horse Growers' Association.....	J. H. Foyle.....	Dubois, Idaho.....	L. E. Dillingham.....	Mackay, Idaho.
Illinois Horse Breeders' Association.....	R. C. Rabain.....	Clifton, Ill.....	J. L. Edmonds.....	University of Illinois, Urbana, Ill.
Illinois Swine Breeders' Association.....	F. E. Drury.....	University of Illinois, Urbana, Ill.	Prof. J. B. Rice.....	University of Illinois, Urbana, Ill.
Illinois Sheep Breeders' Association.....	R. J. Stone.....	Stonington, Ill.....	W. C. Coffey.....	Urbana, Ill.
Illinois Cattle Breeders' and Feeders' Association.....	E. P. Hall.....	Mechanicsburg, Ill.....	J. R. Jones.....	Williamsville, Ill.
Illinois State Dairymen's Association.....	J. P. Mason.....	Elgin, Ill.....	George Caven.....	136 Lake Street, Chicago, Ill.
State Live Stock Association of Illinois.....	John Imboden.....	Decatur, Ill.....	Edw. F. Keefer.....	Union Stock Yards, Chicago, Ill.
Illinois Shorthorn Breeders' Association.....	R. C. Forbes.....	Henry, Ill.....	C. J. McMaster.....	Galesburg, Ill.
Illinois Jersey Cattle Club.....	Carleton Trimble.....	Trimble, Ill.....	Sidney B. Smith.....	Decatur, Ill.
Illinois Chester White Swine Breeders' Association.....	Frank E. Sherer.....	Joy, I.....	H. G. Andrews.....	Sheffield, Ill.
Illinois Percheron Breeders' Association.....	Guy Smith.....	Little York, Ill.....	J. L. Edmonds.....	Urbana, Ill.
Indiana Shorthorn Breeders' Association.....	C. J. Raboin.....	Clifton, Ill.....	W. B. Krueck.....	Purdue University, La Fayette, Ind.
Indiana Cattle Feeders' Association.....	A. E. Harlan.....	Alexandria, Ind.....	F. I. King.....	La Fayette, Ind.
Indiana Guernsey Breeders' Association.....	C. C. Fisher.....	Union City, Ind.....	R. R. McNagny.....	Columbia City, Ind.
Indiana Swine Breeders' Association.....	E. L. Jones.....	Warren, Ind.....	Jas. R. Moore.....	Rochester, Ind.
Indiana Livestock Breeders' Association.....	Ralph Jenkins.....	Orleans, Ind.....	F. G. King.....	La Fayette, Ind.
Indiana Hampshire Swine Breeders' Association.....	F. L. Obenchain.....	Bainbridge, Ind.....	S. F. Hadley.....	Hadley, Ind.
Indiana Aberdeen-Angus Breeders' Association.....	E. J. Barker.....	Thorntown, Ind.....	Prof. C. F. Gobble.....	La Fayette, Ind.
Indiana State Dairy Association.....	G. G. Wharton.....	Marion, Ind.....	C. R. George.....	La Fayette, Ind.
Indiana Hereford Breeders' Association.....	E. M. Wilson.....	Anderson, Ind.....	H. E. Allen.....	La Fayette, Ind.
Indiana Duroc Swine Breeders' Association.....	B. H. Seranton.....	Rising Sun, Ind.....	E. K. Morris.....	Indianapolis, Ind.
Indiana State Poland-China Breeders' Association.....	Frank Fox.....	Indianapolis, Ind.....	T. D. Kelsay.....	Converse, Ind.
Illinois State Hereford Breeders' Association.....	Geo. O. Bartley.....	Switz City, Ind.....	H. P. Rusk.....	Agricultural Experiment Station, Urbana, Ill.
	R. G. East.....	Shelbyville, Ind.....		
	A. N. Abbott.....	Morrison, Ill.....		
Iowa Shorthorn Breeders' Association.....	Harry Hopley.....	Atlantic, Iowa.....	E. R. Silliman.....	Colo, Iowa.

Interstate Shorthorn Breeders' Association.....	H. E. DeVries.....	Hull, Iowa.....	J. E. Halsey.....	505 Eleventh Street, Sioux City, Iowa.
Iowa Holstein-Friesian Breeders' Association.....	J. F. Cass.....	Waterloo, Iowa.....	C. F. Jenness.....	Waterloo, Iowa.
Iowa Swine Breeders' Association.....	F. H. Sixsmith.....	Orient, Iowa.....	M. P. Hancher.....	Rolfe, Iowa.
Iowa Beef Producers' Association.....	W. B. Seeley.....	Mount Pleasant, Iowa.....	E. B. Thomas.....	Audubon, Iowa.
Iowa Polled Hereford Breeders' Association.....	N. M. Leonard.....	Waukeee, Iowa.....	J. E. Kirstein.....	Clarion, Iowa.
Iowa Fleece Wool Growers' Association.....	W. W. Latta.....	Logan, Iowa.....	F. C. Stone.....	Ames, Iowa.
Iowa State Dairy Association.....	Mr. Murphy.....	Waukon, Iowa.....	R. E. Clemons.....	Waterloo, Iowa.
Iowa Sheep Breeders' and Wool Growers' Association.....	V. N. Casady.....	Troy, Iowa.....	V. G. Warner.....	Bloomfield, Iowa.
Kansas Ayrshire Breeders' Association.....	H. H. Hoffman.....	Abilene, Kans.....	Jas. W. Linn.....	Manhattan, Kans.
Kansas Hereford Breeders' Association.....	J. O. Southard.....	Comiskey, Kans.....	E. D. George.....	Council Grove, Kans.
Kansas Live Stock Association.....	Geo. Donaldson.....	Greensburg, Kans.....	J. H. Mercer.....	Topeka, Kans.
Kansas Swine Breeders' Association.....	Fred B. Caldwell.....	Topeka, Kans.....	E. F. Ferrin.....	Manhattan, Kans.
Kansas Sheep and Wool Growers' Association.....	A. L. Stockwell.....	Larned, Kans.....	A. M. Paterson.....	Manhattan, Kans.
Kansas Horse Breeders' Association.....	D. F. McAlister.....	Topeka, Kans.....	F. W. Bell.....	Manhattan, Kans.
Kansas State Dairy Association.....	George Lenhart.....	Abilene, Kans.....	W. E. Petersen.....	Manhattan, Kans.
Kansas Hampshire Swine Breeders' Association.....	Col. F. B. Wempe.....	Frankfort, Kans.....	George W. Eia.....	Valley Falls, Kans.
Holstein-Friesian Association of Kansas.....	George B. Appleman.....	Mulvane, Kans.....	A. S. Neale.....	Manhattan, Kans.
Kentucky Beef Cattle Association.....	C. H. Boyer.....	Lexington, Ky.....	E. S. Good.....	Lexington, Ky.
Kentucky Trotting Horse Breeders' Association of Lexington, Ky.....	Ed. A. Tipton.....	Lexington, Ky.....	J. W. Williams.....	Lexington, Ky.
Kentucky Sheep Breeders' Association.....	Dr. R. H. Stevenson.....	Lexington, Ky.....	E. S. Good.....	Lexington, Ky.
Kentucky Holstein-Friesian Association.....	Jas. Reed.....	Lexington, Ky.....	Joe S. Lindsay.....	Lexington, Ky.
Kentucky Dairy Cattle Club.....	Harry Hartke.....	Erlanger, Ky.....	J. J. Hooper.....	Lexington, Ky.
Kentucky Horse, Mule and Jack Stock Breeders' Association.....	M. S. Cohen.....	Frankfort, Ky.....	W. S. Anderson.....	Lexington, Ky.
Kentucky Purebred Live Stock Association.....	C. E. Marvin.....	Paynes Depot, Ky.....	L. B. Shropshire.....	604 Republic Building, Louisville, Ky.
Louisiana Swine Breeders' Association.....	O. P. Geren.....	836 Common Street, New Orleans, La.....	J. B. Francioni, jr.....	Baton Rouge, La.
Beef Cattle Breeders' Association of Louisiana.....	John Cockerham.....	Luella, La.....	C. C. Chapman.....	De Ridder, La.
Maine Ayrshire Breeders' Association.....	A. F. Dean.....	Portland, Me.....	John A. Ness.....	Auburn, Me.
New England Hereford Breeders' Association.....	Harvey Deaton.....	Waterville, Me.....	Stephen J. Adams.....	Cornish, Me.
Maine Live Stock Breeders' Association.....	A. E. Hodges.....	Fairfield Center, Me.....	Edward W. Morton.....	Orono, Me.
Maine Holstein-Friesian Breeders' Association.....	H. H. Nash.....	Camden, Me.....	Harold J. Shaw.....	Sanford, Me.
Maine Shorthorn Breeders' Association.....	C. I. Gilbert.....	Greene, Me.....	H. M. Tucker.....	Department of Agriculture, Augusta, Me.
Maine Dairymen's Association.....	Dr. J. A. Ness.....	Auburn, Me.....	I. W. Heaps.....	Pylesville, Md.
Maryland State Dairymen's Association.....	D. G. Harry.....	Pylesville, Md.....	G. H. Hibberd.....	Lutherville, Md.
Holstein-Friesian Breeders' Club of Maryland.....	John M. Dennis.....	Lutherville, Md.....	R. M. Handy.....	Barre, Mass.
New England Ayrshire Club.....	H. M. Kimball.....	Concord, N. H.....	W. P. B. Lockwood.....	Amherst, Mass.
Massachusetts Dairymen's Association.....	B. W. Potter.....	Worcester, Mass.....	George A. Brown.....	East Lansing, Mich.
Michigan Improved Live Stock Breeders' and Feeders' Association.....	Herbert Powell.....	Ionia, Mich.....	E. N. Ball.....	Hamburg, Mich.
Michigan Merino Sheep Breeders' Association.....	H. L. Mayo.....	Nashville, Mich.....	J. F. Dexter.....	Lansing, Mich., R. F. D.
Central Michigan Holstein Breeders' Association.....	H. D. Box.....	Lansing, Mich., R. F. D.....	Martin Seidel.....	Bay City, Mich.
Michigan Dairymen's Association.....	R. F. Frary.....	Lapeer, Mich.....	Russell H. Kelty.....	East Lansing, Mich.
Michigan Bee-Keepers' Association.....	A. P. Button.....	Ortonville, Mich.....	George Prescott, jr.....	Tawas City, Mich.
Michigan Live Stock Exhibitors' Association.....	Alex. Minty.....	Ionia, Mich.....	J. B. Miller.....	Ithaca, Mich.
Michigan Duroc-Jersey Swine Breeders' Association.....	O. F. Foster.....	Pavilion, Mich.....		

LIVE-STOCK ASSOCIATIONS—Continued.

STATE ASSOCIATIONS—Continued.

Name of association.	President.	Address.	Secretary.	Address.
Michigan Berkshire Breeders' Association	J. L. Miller	Caledonia, Mich.	B. B. Perry	Leslie, Mich.
Michigan Poland-China Swine Breeders' Association	J. R. Hawkins	Hudson, Mich.	J. K. Mayshead	Ousea, Mich.
Michigan O. I. C. and Chester White Swine Breeders' Association	Fred Nickel	Monroe, Mich.	A. J. Barker	Belmont, Mich.
Michigan Swine Breeders' Association	W. C. Taylor	Milan, Mich.	R. E. Leonard	St. Louis, Mich.
Michigan State Oxford Down Sheep Breeders' Association	Wm. J. Rourke	Owosso, Mich.	I. R. Waterbury	Detroit, Mich.
Michigan Sheep Breeders' and Feeders' Association	E. G. Read	Richland, Mich.	W. H. Schantz	Hastings, Mich.
Michigan Red Polled Cattle Breeders' Association	N. C. Herbison	Birmingham, Mich.	E. J. Peabody	Grand Ledge, Mich.
Michigan Aberdeen-Angus Breeders' Association	Alexander Minty	Ionia, Mich.	Ward Hathaway	Ovid, Mich.
Michigan Hereford Breeders' Association	Jay Harwood	Ionia, Mich.	Earl C. McCarty	Bad Axe, Mich.
Michigan Guernsey Breeders' Association	E. J. Smallidge	Eau Claire, Mich.	Dr. C. G. Parnall	University Hospital, Ann Harbor, Mich.
Michigan Jersey Cattle Club	Alvin Balden	Capec, Mich.	Alfred Hendrickson	Shelby, Mich.
Michigan Holstein-Friesian Association	M. W. Wentworth	Battle Creek, Mich.	C. A. Danie's	Okemos, Mich.
Michigan Shorthorn Breeders' Association	Jay Smith	Ann Arbor, Mich.	W. W. Knapp	Howell, Mich.
Central Michigan Shorthorn Breeders' Association	C. W. Crum	McBride, Mich.	Oscar Skinner	Gowen, Mich.
Michigan Horse Breeders' Association	Jacob De Gens	Alicia, Mich.	R. S. Hudson	East Lansing, Mich.
Minnesota Red Polled Breeders' Association	George P. Grout	Nickerson, Minn.	F. W. Foote	Red Wing, Minn.
Minnesota State Poland-China Breeders' Association	H. W. Van Valkenburg	Osakis, Minn.	Chas. E. Walker	Glencoe, Minn.
Minnesota Sheep Breeders' Association	J. L. Morton	St. Cloud, Minn.	P. A. Anderson	University Farm, St. Paul, Minn.
Minnesota Guernsey Breeders' Association	Geo. P. Grout	Nickerson, Minn.	L. V. Wilson	University Farm, St. Paul, Minn.
Minnesota Cattle Breeders' Association	J. S. Montgomery	Owatonna, Minn.	Frank E. Millard	Canby, Minn.
Minnesota Horse Breeders' Association	L. W. Orr	Hastings, Minn.	J. F. Kuehn	University Farm, St. Paul, Minn.
Minnesota Shorthorn Breeders' Association	Clyde C. Lee	Villard, Minn.	F. C. Landon	Winona, Minn.
Minnesota Holstein Breeders' Association	E. T. Winship	Owatonna, Minn.	Bertram Scott	Hotel Hastings, Minneapolis, Minn.
Minnesota Swine Breeders' Association			Robert Zengerle	Stillwater, Minn.
Minnesota Jersey Cattle Club	J. J. Bacheller	Forest Lake, Minn.	Geo. S. Taylor	Hugo, Minn.
Minnesota Ayrshire Association	Arthur H. Barnard	Lumber Exchange, Minneapolis, Minn.	George J. Chambers	Owatonna, Minn.
Minnesota Live Stock Breeders' Association	Thos. E. Cashman	Owatonna, Minn.	W. A. McKerrow	University Farm, St. Paul, Minn.
Northwest Missouri Hereford Breeders' Association	James B. McNeerney	Coin, Iowa	Howard E. French	Kellerton, Iowa.
Central Shorthorn Breeders' Association	Park E. Salter	Wichita, Kans.	J. A. Forsythe	Pleasant Hill, Mo.
Southwest Missouri Shorthorn Breeders' Association	W. L. Allen	Mount Vernon, Mo., R. F. D. No. 1.	Clinton Marbut	Verona, Mo.
Missouri Duroc Jersey Swine Breeders Association (Inc.)	George E. Thomson	Columbia, Mo.	R. L. Hill	Columbia, Mo.
Missouri State Dairy Association	E. G. Bennett	Jefferson City, Mo.	E. M. Harmon	Columbia, Mo.
Missouri Poland China Swine Breeders' Association	J. P. Bennett	Lees Summit, Mo.	C. H. Walker	600 Graphic Arts Building, Kansas City, Mo.
Missouri Live Stock Producers' Association	S. P. Houston	Malta Bend, Mo.	S. T. Simpson	Columbia, Mo.
Missouri Draft Horse Breeders' Association	J. Scott Miller	Chillicothe, Mo.	E. A. Trowbridge	Columbia, Mo.

Missouri Saddle Horse Breeders' Association. (Practically defunct.)			E. A. Trowbridge	Columbia, Mo.
Chester Breeders' Association of Missouri	J. H. McAnaw	Cameron, Mo.	Sidney D. Frost	Kingston, Mo.
Southwest Jersey Cattle Breeders' Association	M. L. Galloday	Holden, Mo.	Robt. W. Barr	Independence, Mo.
Missouri Holstein Breeders' Association	C. M. Long	Sedalia, Mo.	C. E. Driver	Crescent, Mo.
Missouri Hampshire Swine Association	Isom J. Martin	Kahoka, Mo.	Mrs. C. I. Ward	Cameron, Mo.
Montana Horse Breeders' Association	Harry L. Smith	Bozeman, Mont.	E. H. Riley	Bozeman, Mont.
Montana Live Stock Commission	J. H. Burke	Hogan, Mont.	E. A. Phillips	Helena, Mont.
Montana Purebred Hog Breeders' Association	P. J. Meloy	Townsend, Mont.	Albert R. Whitney	Belgrade, Mont., R. F. D. 1.
Montana State Dairymen's Association	F. M. Eccles	Hamilton, Mont.	W. E. Tomson	Bozeman, Mont.
Montana Stock Growers' Association	R. P. Heren	Miles City, Mont.	D. W. Raymond	Helena, Mont.
Montana Shorthorn Breeders' Association	C. F. Axtell	Salesville, Mont.	W. W. Wheeler	Great Falls, Mont.
Mississippi Shorthorn Breeders' Association	Roland W. Jones	Granada, Miss.	C. G. Bingham	Carrollton, Miss.
Mississippi Aberdeen-Angus Breeders' Association	A. Olson	Elliott, Miss.	M. T. Aldrich	Michigan City, Miss.
Mississippi Hereford Cattle Breeders' Association	Percy H. Anderson	Holly Springs, Miss.	E. K. Middleton	Pocahontas, Miss.
Mississippi Live Stock and Dairy Association	C. H. Cocks	Crawford, Miss.	Archibald Smith	Natchez, Miss.
Nebraska Red Polled Cattle Association	Luke Wiles	Plattsmouth, Nebr.	Elliott R. Davis	Lincoln, Nebr.
Nebraska State Swine Breeders' Association	Sam McKelvie	Fairfield, Nebr.	Elmer J. Lamb	Lincoln, Nebr.
Nebraska Improved Live Stock Breeders' Association	Charles Graff	Panocroft, Nebr.	H. J. Gramlich	University Farm, Lincoln, Nebr.
Nebraska Dairymen's Association	H. A. Morrison	College View, Nebr.	J. E. Palm	Lindell Hotel, Lincoln, Nebr.
Nebraska Shorthorn Breeders' Association	Hon. A. C. Shallenberger	Alma, Nebr.	C. McCarthy	R. F. D. 5, York, Nebr.
Nebraska Horse Breeders' Association	H. J. McLauphin	Doniphan, Nebr.	H. J. Gramlich	Lincoln, Nebr.
Nebraska Hereford Breeders' Association	Glenn E. Stryker	Callaway, Nebr.	C. B. Berger	Callaway, Nebr.
Nebraska Aberdeen-Angus Breeders' Association	F. Hoffmeister	Imperial, Nebr.	D. K. Robertson	Madison, Nebr.
Nebraska Live Stock Feeders' Association	Z. F. Leftwich	Desoto, Nebr.	K. F. Waner	University Farm, Lincoln, Nebr.
Chester Breeders' Association of Nebraska	H. L. Bode	Friend, Nebr.	C. H. Murray	Friend, Nebr.
Granite State Dairymen's Association	Roy D. Hunter	West Claremont, N. H.	J. M. Fuller	Durham, N. H.
Nevada Livestock Association	J. Sheehan	Winnemucca, Nev.	Vernon Metcalf	307 Nixon Building, Reno, Nev.
New Hampshire Sheep Breeders' Association	W. H. Neal	Meredith, N. H.	A. G. Perry	Meredith, N. H.
New Hampshire Holstein-Friesian Club	J. W. Prentiss	Alstead, N. H.	C. A. Preston	Contoocook, N. H.
New Hampshire Ayrshire Cattle Breeders' Club	H. F. Towne	Manchester, N. H.	Geo. H. Yeaton	Dover, N. H.
Jersey Cattle Association of New Jersey	C. R. Hires	Salem, N. J.	Fred Huyler	Gladstone, N. J.
New Jersey Holstein-Friesian Breeders' Association	Louis H. Schenck	Somerville, N. J.	Jacob Todd, jr.	Somerville, N. J.
New Jersey Guernsey Breeders' Association	E. T. Gill	Haddonfield, N. J.	Chas. D. Cleveland	Eatontown, N. J.
New Mexico Cattle and Horse Growers' Association	Victor Culberson	Silver City, N. Mex.	Bertha Benson	Box 617, Albuquerque, N. Mex.
New Mexico Wool Growers' Association	E. M. Otero	Los Lunas, N. Mex.	Walter M. Connell	Albuquerque, N. Mex.
New York State Berkshire Association	W. S. Hinchey	Rochester, N. Y.	W. W. Stewart	Linwood, N. Y.
New York State Jersey Cattle Club	Harry S. Gail	East Aurora, N. Y.	C. O. Gould	East Hampton, N. Y.
New York State Sheep Breeders' Association	J. C. Duncan	Lewiston, N. Y.	J. Stanley Pratt	Knowlesville, N. Y.
New York State Dairymen's Association	Prof. H. C. Troy	Ithaca, N. Y.	T. E. Tiquin	Agricultural Hall, Albany, N. Y.
New York State Breeders' Association	Calvin J. Huson	Penn Yan, N. Y.	Albert E. Brown	18 South Lake Avenue, Albany, N. Y.
Holstein-Friesian Breeders' Club of New York State	H. V. Noyes	Oneida, N. Y.	F. T. Price	Syracuse, N. Y.
New York State Draft Horse Breeders' Club	E. S. Akin	909 Ackerman Avenue, Syracuse, N. Y.	E. E. Horton	Johnson City, N. Y.
New York State Guernsey Association	J. R. Clancey	1000 W. Belden Avenue, Syracuse, N. Y.	C. H. Hechler	Roslyn, N. Y.
American Campine Club	Arthur I. Hoe	Bedford Hills, N. Y.	Mrs. Chas. H. Owings	Dumont, N. Y.
North Carolina Beef Breeders' and Feeders' Association	J. E. Latham	Greensboro, N. C.	R. S. Curtis	West Raleigh, N. C.
North Carolina Poultry Association	J. P. Kerr	Haw River, N. C.	D. F. Kaupp	West Raleigh, N. C.
North Carolina Dairymen's Association	D. J. Lybrook	Winston-Salem, N. C.	Alvin J. Reed	West Raleigh, N. C.

LIVE-STOCK ASSOCIATIONS—Continued.

STATE ASSOCIATIONS—Continued.

Name of association.	President.	Address.	Secretary.	Address.
North Carolina Swine Breeders' Association.....	W. W. Shay.....	West Raleigh, N. C.....	Dan T. Gray.....	West Raleigh, N. C.
North Dakota Livestock Association.....	A. H. White.....	Kramer, N. Dak.....	Burke H. Critchfield..	Box 213, Fargo, N. Dak.
United Stock Breeders' Association.....	W. P. Hetler.....	Esmond, N. Dak.....	J. C. McMillen.....	Esmond, N. Dak.
Golden Wyandotte Club.....	I. C. Keller.....	Prospect, Ohio.....	J. S. Pennington.....	Plainfield, Ill.
Ohio Belgian Breeders' Association.....	M. M. Chaffin.....	Galena, Ohio.....	D. J. Kays.....	Ohio State University, Columbus, Ohio.
Ohio Percheron Breeders' Association.....	W. H. Butler.....	Sandusky, Ohio.....	D. J. Kays.....	Ohio State University, Columbus, Ohio.
Ohio Jersey Cattle Club.....	Walter E. Brown.....	Youngstown, Ohio.....	P. J. Cummings.....	Fredericktown, Ohio.
Ohio Holstein-Friesian Association.....	A. W. Green.....	Middlefield, Ohio.....	Paul McNish.....	Burton, Ohio.
Ohio Shropshire Breeders' Association.....	L. B. Palmer.....	Pataskala, Ohio.....	Ralph A. Postle.....	Camp Chase, Ohio.
Ohio Shorthorn Breeders' Association.....	J. A. Huston.....	Granville, Ohio.....	P. G. Ross.....	Mansfield, Ohio.
Ohio Red Poll Breeders' Association.....	Homer C. Price.....	Newark, Ohio.....	Frank Nelson.....	London, Ohio.
Ohio Galloway Cattle Breeders' Association.....	James Frantz.....	R. F. D. 4, Bluffton, Ohio.....	G. D. Simmons.....	Hicksville, Ohio.
Ohio State Dairymen's Association.....	H. W. Ingersoll.....	Elyria, Ohio.....	O. Erf.....	Ohio State University, Columbus, Ohio.
Ohio Guernsey Breeders' Association.....	A. C. Ramseyer.....	Smithville, Ohio.....	H. C. McCamon.....	Lisbon, Ohio.
Ohio Hereford Breeders' Association.....	Jas. V. Hill.....	Roundhead, Ohio.....	J. B. Fernow.....	Leesburg, Ohio.
Ohio Rambouillet Breeders' Association.....	C. P. Raup.....	Springfield, Ohio.....	L. C. Orth.....	McGuffey, Ohio.
Ohio State Chester White Breeders' Association.....	I. T. Cummins.....	Xenia, Ohio.....	F. A. C. Schwietermann	Montezuma, Ohio.
Ohio Ayrshire Breeders' Association.....	S. B. McConnell.....	Wellington, Ohio.....	Lawrence Belts.....	Wellington, Ohio.
Oklahoma Hereford Breeders' Association.....	F. H. Reiley.....	Shawnee, Okla.....	Keith Sellars.....	Okarche, Okla.
Oklahoma Aberdeen-Angus Breeders' Association.....	John Simpson.....	Eufaula, Okla.....	E. E. Blanford.....	Hayward, Okla.
Oklahoma Shorthorn Breeders' Association.....	H. T. Blake.....	Duncan, Okla.....	R. N. Brittan.....	Waukomis, Okla.
Oregon Guernsey Club.....	J. I. Whalley.....	Portland, Oreg.....	R. G. Fowler.....	Carlton, Oreg.
Oregon-Jersey Cattle Club.....	W. K. Taylor.....	Corvallis, Oreg.....	S. Fine.....	Corvallis, Oreg.
Farmers' Dairy Association.....	C. A. Bear.....	.....	S. A. Riches.....	Turner, Oreg.
Oregon Dairymen's Association.....	C. L. Hainley.....	McCoy, Oreg.....	P. M. Brandt.....	Corvallis, Oreg.
Northwest Shorthorn Association.....	A. D. Dunn.....	Wapato, Wash.....	E. L. Potter.....	Corvallis, Oreg.
Oregon Horse Breeders' Association.....	W. R. Ledbetter.....	La Grande, Oreg.....	D. E. Richards.....	Corvallis, Oreg.
Oregon Purebred Live Stock Association.....	Hon. C. L. Hawley.....	McCoy, Oreg.....	N. C. Maris.....	35 East Ninth Street, North Portland, Oreg.
American Dragon Club.....	A. Bateman.....	303 Vine Street, Camden, N. J..	H. B. Behrens.....	5536 North Lawrence Street, Philadelphia,
State Holstein-Friesian Association of Pennsylvania.....	Eugene B. Bennett.....	Box 193, Easton, Pa.....	H. C. Reynolds.....	Dalton, Pa.
Pennsylvania Berkshire Breeders' Association.....	E. S. Deubler.....	Narberth, Pa.....	W. W. Blake Arkcoll..	New Hope, Pa.
Pennsylvania Sheep Breeders' Association.....	R. L. Munce.....	Washington, Pa.....	J. B. Henderson.....	Hickory, Pa.
South Carolina Live Stock Association.....	R. M. Cooper, jr.....	Wisacky, S. C.....	T. O. Lawton.....	Garnett, S. C.
South Dakota Dairymen's and Buttermakers' Association.....	Chas. Anderson.....	Howard, S. Dak.....	A. P. Ryger.....	Brookings, S. Dak.
South Dakota Holstein-Friesian Association.....	Prof. C. Larsen.....	Brookings, S. Dak.....	T. E. Gage.....	Groton, S. Dak.
South Dakota Improved Live Stock and Poultry Breeders' Association.....	John M. Erion.....	Mitchell, S. Dak.....	James W. Wilson.....	Brookings, S. Dak.
South Dakota Swine Breeders' Association.....	George E. Barkley.....	Sioux Falls, S. Dak.....	R. N. Cuykendall.....	Aberdeen, S. Dak.

Southern Cattlemen's Association	J. H. Cockerham	Luella, La.	E. R. Lloyd	Memphis, Tenn.
Texas Jack and Mule Breeders' Association	J. W. Shephard	Plano, Tex.	S. L. Green	Celeste, Tex.
Southwestern Cattlemen's Association			W. L. Amonett	Box 806, El Paso, Tex.
Panhandle & Southwestern Stockmen's Association	L. C. Brite	Marfa, Tex.	J. N. Sanburn	El Paso, Tex.
Cattle Raisers' Association of Texas	W. W. Turney	Box 81, Route 3, El Paso, Tex.	E. B. Spiller	Fort Worth, Tex.
Texas Jersey Cattle Club	D. T. Simonds	Fort Worth, Tex.	Mrs. J. Riley Green	Wolfe City, Tex.
Texas Shorthorn Breeders' Association	G. E. King	Taylor, Tex.	L. B. Brown	Smithfield, Tex.
Texas Hereford Association	B. C. Rhome, jr.	Fort Worth, Tex.	John P. Lee	San Angelo, Tex.
Texas Swine Breeders' Association	Lon Alexander	Childress, Tex.		
Texas Aberdeen-Angus Breeders' Association	Prof. John C. Burns	College Station, A. and M. of Tex.	W. M. Hill	Christoval, Tex.
Utah State Dairymen's Association	W. C. Winder	Salt Lake City, Utah	G. B. Caine	Logan, Utah.
Vermont Guernsey Breeders' Association	M. H. Moody	Waterbury, Vt.	J. P. Ramsey	Charlotte, Vt.
Vermont Jersey Cattle Club	H. M. Lee	Windsor, Vt.	Guy Tiffany	East Berkshire, Vt.
Vermont Ayrshire Club	G. H. Dunsmore	R. F. D., Swanton, Vt.	C. N. Smith	Brandon, Vt.
Vermont Holstein Club	G. F. Gregory	Brattleboro, Vt.	F. L. Parmelee	Putney, Vt.
New England Shorthorn Breeders' Association	David Barnard	Shelbourn, Mass.	W. A. Simpson	Lyndonville, Vt.
Holstein-Friesian Club of Virginia	J. A. Turner	Hollins, Va.	R. V. Martindale	Sweet Briar, Va.
Virginia State Dairymen's Association	F. S. Walker	Woodberry Forest, Va.	A. F. Howard	Farmville, Va.
Washington Pure Bred Live Stock Association	G. M. Wilson	Rocklyn, Wash.	A. H. Paston	R. F. D., Spokane, Wash.
Washington Holstein Breeders' Association	Wm. Bishop	Chimacum, Wash.	A. B. Winter	Everett, Wash.
West Virginia Livestock Association	Howard M. Gare	Clarksburg, W. Va.		
West Virginia Shorthorn Breeders' Association	A. DeWitt Pierce	Moundsville, W. Va.		
Wisconsin Sheep Breeders' Association	W. Woodard	Bloomer, Wis.	W. F. Renk	Sun Prairie, Wis.
Wisconsin Ayrshire Breeders' Association	Stephen Bull	Racine, Wis.	A. J. McNab	Black River Falls, Wis.
Wisconsin Dairymen's Association	Chas. A. Peterson	Rosendale, Wis.	Paul C. Burchard	Fort Atkinson, Wis.
Wisconsin Poland China Breeders' Association	F. A. Morehouse	Lancaster, Wis.	Burlie Dobson	Lancaster, Wis.
Wisconsin Chester White Breeders' Association	James Fisher	Eastman, Wis.	B. H. Babcock	Evansville, Wis.
Wisconsin Live Stock Breeders' Association	W. L. Houser	Mondovi, Wis.	Andrew W. Hopkins	Madison, Wis.
Wisconsin Shorthorn Breeders' Association	E. R. Williams	Bangor, Wis.	J. L. Tormey	17 Butler St., Madison, Wis.
Wisconsin Brown Swiss Cattle Breeders' Association	M. L. Ayers	Burlington, Wis.	B. H. Hibbard	Madison, Wis.
Wisconsin Hampshire Swine Breeders' Association	A. L. Damon	Richland Center, Wis.	W. W. Meacham	Downing, Wis.
Wisconsin Hereford Cattle Breeders' Association	Irving Jewell	Mineral Point, Wis.	C. W. Thompson	Walworth, Wis.
Wisconsin Horse Breeders' Association	J. A. Wood	Marshall, Wis.	Prof. J. G. Fuller	Madison, Wis.
Wisconsin Aberdeen-Angus Breeders' Association	Parke Gelbach	Lancaster, Wis.	Prof. J. G. Fuller	Madison, Wis.
Wisconsin Holstein Breeders' Association	S. H. Bird	South Byron, Wis.	C. J. Schraeder	Mayville, Wis.
Wisconsin Jersey Breeders' Association	W. H. Clark	Rice Lake, Wis.	Charles Peterson	Rosendale, Wis.
Western Guernsey Breeders' Association	Charles L. Hill	Rosendale, Wis.	Dr. M. B. Wood	Mankato, Minn.
Holstein-Friesian Breeders' Association	S. H. Bird	South Byron, Wis.	J. R. Garver	Pioneer Building, Madison, Wis.



# STATISTICS OF GRAIN CROPS, 1919.

## CORN.

TABLE 1.—*Corn: Area and production in undermentioned countries, 1909–1919.*

[000 omitted.]

Country.	Area.				Production.			
	Average 1909– 1913. <sup>1</sup>	1917	1918	1919	Average 1909– 1913. <sup>1</sup>	1917	1918	1919
<b>NORTH AMERICA.</b>								
United States.....	<i>Acres.</i> 104,229	<i>Acres.</i> 116,730	<i>Acres.</i> 104,467	<i>Acres.</i> 102,075	<i>Bushels.</i> 2,708,334	<i>Bushels.</i> 3,065,233	<i>Bushels.</i> 2,502,665	<i>Bushels.</i> 2,917,450
Canada:								
Ontario.....	291	160	195	221	17,436	5,960	13,015	11,492
Quebec.....	24	74	55	44	736	1,833	1,190	1,199
Other.....					6			
Total.....	315	234	250	285	18,178	7,763	14,205	12,691
Mexico.....	11,554	(2)	(2)	(2)	164,657	(2)	75,985	(2)
Total.....	116,098				2,891,169		2,592,855	
<b>SOUTH AMERICA.</b>								
Argentina.....	8,128	8,969	8,715	(2)	174,502	58,839	170,660	(2)
Chile.....	56	49	65	65	1,390	1,338	1,446	1,702
Uruguay.....	551	627	(2)	(2)	6,027	6,815	7,086	(2)
Total.....	8,735	9,645			181,919	66,992	179,192	
<b>EUROPE.</b>								
Austria <sup>2</sup> .....	761	(2)	(2)	(2)	14,536	(2)	(2)	(2)
Hungary proper <sup>3</sup> .....	6,038	(2)	(2)	(2)	168,081	(2)	(2)	(2)
Croatia-Slavonia <sup>3</sup> .....	1,036	(2)	(2)	(2)	24,873	(2)	(2)	(2)
Bosnia-Herzegovina <sup>3</sup> .....	578	(2)	(2)	(2)	9,111	(2)	(2)	(2)
Bulgaria <sup>2</sup> .....	1,544	(2)	(2)	(2)	28,219	(2)	(2)	(2)
France <sup>2</sup> .....	1,155	847	734	756	22,229	14,904	8,743	(2)
Italy.....	3,931	3,572	3,459	3,583	100,349	75,452	66,925	79,000
Portugal.....	(2)	(2)	(2)	(2)	15,000	(2)	(2)	(2)
Roumania <sup>2</sup> .....	5,143	(2)	4 5,728	4 6,180	100,620	(2)	(2)	(2)
Russia proper <sup>2</sup> .....	3,173	(2)	(2)	(2)	56,571	(2)	(2)	(2)
Northern Caucasus <sup>2</sup> .....	750	(2)	(2)	(2)	13,651	(2)	(2)	(2)
Serbia <sup>2</sup> .....	1,445	(2)	(2)	(2)	28,128	(2)	(2)	(2)
Spain.....	1,134	1,175	1,169	1,195	26,548	29,369	24,141	24,533
Switzerland.....	(2)	5	7	6	(2)	252	358	287
Total.....	26,688				607,916			
<b>ASIA.</b>								
British India.....	6,340	6,544	6,274	(2)	87,240	93,760	92,680	(2)
Japan.....	130	138	144	136	3,637	3,791	3,757	(2)
Philippine Islands.....	992	1,058	1,034	(2)	7,446	13,441	11,271	(2)
Total.....	7,462	7,740	7,452		98,323	110,992	107,708	
<b>AFRICA.</b>								
Algeria.....	34	20	(2)	17	461	302	(2)	236
Egypt.....	1,857	1,685	1,800	(2)	64,220	63,757	(2)	(2)
Union of South Africa.....	(2)	3,150	3,300	2,950	26,498	36,516	45,143	41,289
Total.....	1,891	4,855			91,179	100,575		
<b>AUSTRALASIA.</b>								
Australia:								
Queensland.....	143	181	(2)	(2)	3,280	3,019	(2)	(2)
New South Wales.....	190	155	(2)	(2)	6,091	4,333	(2)	(2)
Victoria.....	18	23	(2)	(2)	887	1,172	(2)	(2)
Western Australia.....	(2)	(2)	(2)	(2)	1	1	(2)	(2)
South Australia.....	1	(2)	(2)	(2)	5	1	(2)	(2)
Total Australia.....	352	359	332		10,264	8,526	8,843	
New Zealand.....	10	6	8	10	493	274	368	415
Total Australasia.....	362	365	340		10,757	8,800	9,211	
Grand total.....	161,236				3,881,263			

<sup>1</sup> Five-year average except in a few cases where statistics for 5 years were not available.

<sup>2</sup> No official statistics.

<sup>3</sup> Old boundaries.

<sup>4</sup> Including Bessarabia but excluding Dobrudja.

## CORN—Continued.

TABLE 2.—Corn: Total production of countries named in Table 1, 1895-1916.

Year.	Production.	Year.	Production.	Year.	Production.	Year.	Production.
	<i>Bushels.</i>		<i>Bushels.</i>		<i>Bushels.</i>		<i>Bushels.</i>
1895....	2,834,750,000	1901.....	2,366,883,000	1907.....	3,420,321,000	1913.....	3,587,429,000
1896....	2,964,435,000	1902.....	3,187,311,000	1908.....	3,606,931,000	1914.....	3,777,913,000
1897....	2,587,206,000	1903.....	3,066,506,000	1909.....	3,563,226,000	1915.....	4,201,589,000
1898....	2,682,619,000	1904.....	3,109,252,000	1910.....	4,031,630,000	1916.....	3,642,103,000
1899....	2,724,100,000	1905.....	3,461,181,000	1911.....	3,481,007,000		
1900....	2,792,561,000	1906.....	3,963,645,000	1912.....	4,371,888,000		

TABLE 3.—Corn: Acreage, production, value, exports, etc., in the United States, 1849-1919.

NOTE.—Figures in *italics* are census returns; figures in roman are estimates of the Department of Agriculture. Estimates of acres are obtained by applying estimated percentages of increase or decrease to the published numbers of the preceding year, except that a revised base is used for applying percentage estimates whenever new census data are available.

Year.	Acreage.	Average yield per acre.	Production.	Average farm price per bushel Dec. 1.	Farm value Dec. 1.	Chicago cash price per bushel, contract. <sup>1</sup>				Domestic exports, including corn meal, fiscal year beginning July 1.	Per cent of crop exported.
						December.		Following May.			
						Low	High	Low	High		
1849....	<i>Acres.</i>	<i>Bush.</i>	<i>Bushels.</i>	<i>Cents.</i>	<i>Dollars.</i>	<i>Cts.</i>	<i>Cts.</i>	<i>Cts.</i>	<i>Cts.</i>	<i>Bushels.</i>	<i>P. ct.</i>
1859....			592,071,000							7,632,860	1.3
			838,793,000							4,248,991	.5
1866....	34,307,000	25.3	867,946,000	47.4	411,451,000	53	62	64	79	16,026,947	1.8
1867....	32,520,000	23.6	768,320,000	57.0	437,770,000	61	65	61	71	12,493,522	1.6
1868....	34,887,000	26.0	906,527,000	46.8	424,057,000	38	58	44	51	8,286,665	.9
1869....	37,103,000	23.6	874,320,000	59.8	522,551,000	56	67	73	85	2,140,487	.2
1869....			760,945,000								
1870....	38,647,000	28.3	1,094,255,000	49.4	540,520,000	41	59	46	52	10,673,553	1.0
1871....	34,091,000	29.1	991,898,000	43.4	430,356,000	36	39	38	43	35,727,010	3.6
1872....	35,527,000	30.8	1,092,719,000	35.3	385,736,000	27	28	34	39	40,154,374	3.7
1873....	39,197,000	23.8	932,274,000	44.2	411,961,000	40	49	49	59	35,985,834	3.9
1874....	41,037,000	20.7	850,148,000	58.4	496,271,000	64	76	53	67	30,025,036	3.5
1875....	44,841,000	29.5	1,321,069,000	36.7	484,675,000	40	47	41	45	50,910,532	3.9
1876....	49,033,000	26.2	1,283,828,000	34.0	436,109,000	40	43	43	56	72,652,611	5.7
1877....	50,369,000	26.7	1,342,558,000	34.8	467,635,000	41	49	35	41	87,192,110	6.5
1878....	51,585,000	26.9	1,388,219,000	31.7	440,281,000	30	32	33	36	87,884,892	6.3
1879....	53,085,000	29.2	1,547,902,000	37.5	580,486,000	39	43½	32½	36½	99,572,329	6.4
1879....	62,869,000	28.1	1,754,592,000								
1880....	62,318,000	27.6	1,717,435,000	39.6	679,714,000	35½	42	41½	45	93,648,147	5.5
1881....	64,262,000	18.6	1,194,916,000	63.6	759,482,000	58½	63½	69	76½	44,340,683	3.7
1882....	65,660,000	24.6	1,617,025,000	48.5	783,867,000	49½	61	53½	56½	41,655,653	2.6
1883....	68,302,000	22.7	1,551,067,000	42.4	658,051,000	54½	63½	52½	57	46,258,606	3.0
1884....	69,684,000	25.8	1,795,528,000	35.7	640,736,000	34½	40½	44½	49	52,876,456	2.9
1885....	73,130,000	26.5	1,936,176,000	32.8	635,675,000	36	42½	34½	36½	64,829,617	3.3
1886....	75,694,000	22.0	1,665,441,000	36.6	610,311,000	35½	38	36½	39½	41,368,584	2.5
1887....	72,393,000	20.1	1,456,161,000	44.4	646,107,000	47	51½	54	60	25,360,869	1.7
1888....	75,673,000	26.3	1,987,790,000	34.1	677,562,000	33½	35½	33½	35½	70,841,673	3.6
1889....	78,320,000	27.0	2,112,892,000	28.3	597,919,000	29½	35	32½	35	103,418,709	4.9
1889....	72,088,000	29.4	2,122,828,000								
1890....	71,971,000	20.7	1,489,970,000	50.6	754,433,000	47½	53	55	69½	32,041,529	2.2
1891....	76,205,000	27.0	2,060,154,000	40.6	836,439,000	39½	59	40½	100	76,602,285	3.7
1892....	70,627,000	23.1	1,628,464,000	39.4	642,147,000	40	42½	39½	44½	47,121,894	2.9
1893....	72,036,000	22.5	1,619,496,000	36.5	591,626,000	34½	36½	36½	38½	66,489,529	4.1
1894....	62,582,000	19.4	1,212,770,000	45.7	554,719,000	44½	47½	47½	55½	28,585,405	2.4
1895....	82,076,000	26.2	2,151,139,000	25.3	544,986,000	25	26½	27½	29½	101,100,375	4.7
1896....	81,027,000	28.2	2,283,875,000	21.5	491,007,000	22½	23½	23	25½	178,817,417	7.8
1897....	80,095,000	23.8	1,902,968,000	26.3	501,073,000	25	27½	32½	37	212,055,543	11.1
1898....	77,722,000	24.8	1,924,185,000	28.7	552,023,000	33½	38	32½	34½	177,255,046	9.2
1899....	82,109,000	25.3	2,078,144,000	30.3	629,210,000	30	31½	36	40½	213,123,412	10.3
1899....	94,914,000	28.1	2,666,324,000								

<sup>1</sup> No. 2 to 1908.<sup>2</sup> Coincident with "corner."

CORN—Continued.

TABLE 3.—Corn: Acreage, production, value, exports, etc., in the United States, 1849-1919—Continued.

Year.	Acreage.	Average yield per acre.	Production.	Average farm price per bushel Dec. 1.	Farm value Dec. 1.	Chicago cash price per bushel, contract.				Domestic exports, including corn meal, fiscal year beginning July 1.	Per cent of crop exported.
						December.		Following May.			
						Low	High	Low	High		
	<i>Acres.</i>	<i>Bush.</i>	<i>Bushels.</i>	<i>Cents.</i>	<i>Dollars.</i>	<i>Cts.</i>	<i>Cts.</i>	<i>Cts.</i>	<i>Cts.</i>	<i>Bushels.</i>	<i>P. ct.</i>
1900...	83,321,000	25.3	2,105,103,000	35.7	751,220,000	35½	40½	42¾	58½	181,405,473	8.6
1901...	91,350,000	16.7	1,522,520,000	60.5	921,556,000	62½	67½	59½	64¾	28,028,688	1.8
1902...	91,044,000	26.8	2,523,648,000	40.3	1,017,017,000	43¾	57½	44	46	76,639,261	3.0
1903...	88,092,000	25.5	2,244,177,000	42.5	952,869,000	41	43¾	47½	50	58,222,061	2.6
1904...	92,232,000	26.8	2,467,481,000	44.1	1,087,461,000	43½	49	48	64½	90,293,483	3.7
1905...	94,011,000	28.8	2,707,994,000	41.2	1,116,697,000	42	50½	47½	50	119,893,833	4.4
1906...	96,738,000	30.3	2,927,416,000	39.9	1,166,626,000	40	46	49½	56	86,368,228	3.0
1907...	99,931,000	25.9	2,592,320,000	51.6	1,336,901,000	57½	61½	67½	82	55,063,860	2.1
1908...	101,788,000	26.2	2,668,651,000	60.6	1,616,145,000	56¾	62½	72½	76	37,665,040	1.4
1909...	108,771,000	25.5	2,772,376,000	.....	.....	.....	.....	.....	.....	.....	.....
1909...	98,383,000	25.9	2,552,190,000	57.9	1,477,222,000	62½	66	56	63	38,128,498	1.5
1910 <sup>1</sup> ...	104,035,000	27.7	2,886,260,000	48.0	1,384,817,000	45½	50	52½	55½	65,614,522	2.3
1911...	105,825,000	23.9	2,531,488,000	61.8	1,565,258,000	68	70	76½	82½	41,797,291	1.7
1912...	107,083,000	29.2	3,124,746,000	48.7	1,520,454,000	47½	54	55½	60	50,780,143	1.6
1913...	105,820,000	23.1	2,446,988,000	69.1	1,692,092,000	64	73½	67	72½	10,725,819	.4
1914...	103,435,000	25.8	2,672,804,000	64.4	1,722,070,000	62½	68½	50½	56	50,668,303	1.9
1915...	106,197,000	28.2	2,994,793,000	57.5	1,722,680,000	69½	75	69	78½	39,896,928	1.3
1916...	105,296,000	24.4	2,566,927,000	88.9	2,280,729,000	88	96	152	174	66,753,294	2.6
1917...	116,730,000	26.3	3,065,233,000	127.9	3,920,228,000	160	190	150	170	49,073,263	1.6
1918...	104,467,000	24.0	2,502,665,000	136.5	3,416,240,000	135	155	160½	185	23,020,846	.9
1919...	102,075,000	28.6	2,917,450,000	134.9	3,934,234,000	142	160	.....	.....	.....	.....

<sup>1</sup> Figures adjusted to census basis.

TABLE 4.—Corn: Revised acreage, production, and farm value, 1879, and 1889-1909.

NOTE.—This revision for 1879 and 1889-1909 consists (1) in using the Department of Agriculture's estimates of average yield per acre to compute, from census acreage, the total production, (2) in adjusting the department's estimates of acreage for each year so as to be consistent with the following as well as the preceding census acreage, and (3) in recomputing total farm value from these revised production figures.

Year.	Acreage.	Average yield per acre.	Production.	Average farm price per bushel Dec. 1.	Farm value Dec. 1.
	<i>Acres.</i>	<i>Bushels.</i>	<i>Bushels.</i>	<i>Cents.</i>	<i>Dollars.</i>
1879.....	62,369,000	29.2	1,823,163,000	37.1	676,251,000
1889.....	72,088,000	27.7	1,998,648,000	27.4	546,984,000
1890.....	70,390,000	20.7	1,460,406,000	50.0	729,647,000
1891.....	74,496,000	27.6	2,055,823,000	39.7	816,917,000
1892.....	72,610,000	23.6	1,713,688,000	38.8	664,390,000
1893.....	74,434,000	22.9	1,707,572,000	35.9	612,998,000
1894.....	69,396,000	19.3	1,339,680,000	45.1	604,523,000
1895.....	85,567,000	27.0	2,310,952,000	25.0	578,408,000
1896.....	86,560,000	28.9	2,503,484,000	21.3	532,884,000
1897.....	88,127,000	24.3	2,144,553,000	26.0	558,309,000
1898.....	88,304,000	25.6	2,261,119,000	28.4	642,747,000
1899.....	94,914,000	25.9	2,454,626,000	29.9	734,917,000
1900.....	95,042,000	26.4	2,505,148,000	35.1	878,243,000
1901.....	94,636,000	17.0	1,607,288,000	60.0	964,543,000
1902.....	95,517,000	27.4	2,620,699,000	40.0	1,048,735,000
1903.....	90,661,000	25.8	2,339,417,000	42.1	984,173,000
1904.....	93,340,000	27.0	2,520,682,000	43.7	1,101,430,000
1905.....	93,573,000	29.3	2,744,329,000	40.7	1,116,817,000
1906.....	93,643,000	30.9	2,895,822,000	39.2	1,135,969,000
1907.....	94,971,000	26.5	2,512,065,000	50.9	1,277,607,000
1908.....	95,603,000	26.6	2,544,957,000	60.0	1,527,679,000
1909.....	98,383,000	26.1	2,572,336,000	58.6	1,507,185,000

## CORN—Continued.

TABLE 5.—Corn: Acreage, production, and total farm value, by States, 1918 and 1919.

State.	Thousands of acres.		Production (thousands of bushels).		Total value, basis Dec. 1 price (thousands of dollars).	
	1919	1918	1919	1918	1919	1918
Maine.....	20	23	1,100	1,035	2,145	1,728
New Hampshire.....	21	24	1,050	1,080	1,785	1,620
Vermont.....	40	40	2,120	1,520	3,710	2,584
Massachusetts.....	44	45	2,640	2,340	4,541	3,978
Rhode Island.....	11	13	495	572	921	1,030
Connecticut.....	55	56	3,300	2,800	5,940	4,788
New York.....	820	800	35,260	28,800	58,532	50,400
New Jersey.....	270	265	10,800	10,865	16,524	16,298
Pennsylvania.....	1,536	1,479	72,192	59,160	106,122	91,698
Delaware.....	230	230	6,900	7,130	10,005	9,697
Maryland.....	693	686	28,413	24,010	39,778	32,414
Virginia.....	1,600	1,600	44,800	44,800	75,712	71,680
West Virginia.....	735	750	24,990	23,250	40,984	41,850
North Carolina.....	2,900	3,030	55,100	63,630	101,935	112,625
South Carolina.....	2,340	2,175	37,440	36,975	73,757	72,101
Georgia.....	4,820	4,590	69,890	68,850	111,824	113,602
Florida.....	840	800	12,600	12,800	17,640	17,664
Ohio.....	3,700	3,600	162,800	129,600	196,988	168,480
Indiana.....	4,750	5,000	175,750	165,000	219,688	196,350
Illinois.....	8,600	9,700	301,000	344,350	391,300	413,220
Michigan.....	1,650	1,610	64,350	48,300	88,803	62,790
Wisconsin.....	1,820	1,710	85,540	68,742	106,925	89,365
Minnesota.....	2,950	2,780	118,000	111,200	141,600	123,432
Iowa.....	10,000	9,800	416,000	352,800	499,200	430,416
Missouri.....	5,756	6,693	155,412	133,860	214,469	191,420
North Dakota.....	508	484	16,764	9,196	23,470	11,955
South Dakota.....	3,200	3,100	91,200	105,400	108,528	115,940
Nebraska.....	7,030	6,954	184,186	123,086	224,707	157,550
Kansas.....	4,475	6,130	69,362	43,523	97,107	64,849
Kentucky.....	3,300	3,500	82,500	91,000	127,875	132,860
Tennessee.....	3,250	3,250	74,750	78,000	117,358	113,100
Alabama.....	4,334	4,378	62,843	63,919	99,920	94,600
Mississippi.....	3,980	3,900	59,700	66,300	95,520	100,113
Louisiana.....	1,850	1,800	32,375	28,800	48,562	46,368
Texas.....	6,760	6,500	202,800	65,000	239,304	114,400
Oklahoma.....	3,100	3,100	74,400	23,250	94,488	38,130
Arkansas.....	2,707	2,700	48,726	35,100	79,911	63,180
Montana.....	128	100	1,728	2,100	2,851	2,835
Wyoming.....	48	40	768	1,000	1,267	1,400
Colorado.....	671	610	11,206	10,675	15,913	14,411
New Mexico.....	240	160	7,200	4,000	10,872	7,200
Arizona.....	39	34	1,287	952	2,574	1,999
Utah.....	24	24	432	672	648	1,216
Nevada.....	3	2	90	64	126	134
Idaho.....	24	23	840	920	1,386	1,684
Washington.....	45	50	1,620	1,900	2,997	3,230
Oregon.....	71	44	1,860	1,364	2,883	2,114
California.....	87	85	2,871	2,975	5,139	5,742
United States.....	102,175	104,467	2,917,450	2,502,665	3,934,234	3,416,240

CORN—Continued.

TABLE 6.—Corn: Production and distribution in the United States, 1897–1919.

[000 omitted, except in percentage columns.]

Year.	Old stock on farms Nov. 1.	Crop.			Total supplies.	Stock on farms Mar. 1 following.	Shipped out of county where grown.
		Quantity.	Quality.	Proportion merchantable.			
	<i>Bushels.</i>	<i>Bushels.</i>	<i>Per cent.</i>	<i>Per cent.</i>	<i>Bushels.</i>	<i>Bushels.</i>	<i>Bushels.</i>
1897.....	290,934	1,902,968	86.3	86.8	2,193,902	782,871	411,617
1898.....	137,894	1,924,185	83.8	82.2	2,062,079	800,533	396,005
1899.....	113,644	2,078,144	87.2	86.9	2,191,788	773,730	348,098
1900.....	92,328	2,105,103	85.5	86.3	2,197,431	776,166	478,417
1901.....	95,825	1,522,520	73.7	.....	1,618,345	441,132	153,213
1902.....	29,267	2,523,648	83.1	76.2	2,552,915	1,050,653	557,296
1903.....	131,210	2,244,177	86.2	76.0	2,375,387	839,053	419,877
1904.....	80,246	2,467,481	90.6	84.8	2,547,727	954,268	551,635
1905.....	82,285	2,707,994	90.6	88.4	2,790,279	1,108,364	681,539
1906.....	119,633	2,927,416	89.9	89.1	3,047,049	1,297,979	679,544
1907.....	130,995	2,592,320	82.8	77.7	2,723,315	962,429	467,675
1908.....	71,124	2,668,651	86.9	88.2	2,739,775	1,047,763	568,129
1909.....	79,779	2,552,190	84.2	82.5	2,631,969	977,561	635,248
1910.....	115,696	2,886,260	87.2	86.4	3,001,956	1,165,378	661,777
1911.....	123,824	2,531,488	80.6	80.1	2,655,312	884,059	517,766
1912.....	64,764	3,124,746	85.5	85.0	3,189,510	1,290,642	680,831
1913.....	137,972	2,446,988	82.2	80.1	2,584,960	866,352	422,059
1914.....	80,046	2,672,804	85.1	84.5	2,752,850	910,894	498,285
1915.....	96,009	2,994,793	77.2	71.1	3,090,802	1,116,559	560,824
1916.....	87,908	2,566,927	83.8	83.9	2,654,835	782,303	450,589
1917.....	34,448	3,065,233	75.2	60.0	3,099,631	1,253,290	678,027
1918.....	114,678	2,502,665	85.6	82.4	2,617,343	855,269	362,589
1919.....	69,835	2,917,450	89.1	86.9	2,987,285	1,092,059	474,139

## CORN—Continued.

TABLE 7.—Corn: Yield per acre, price per bushel Dec. 1, and value per acre, by States.

State.	Yield per acre (bushels).										Farm price per bushel (cents).					Value per acre (dollars). <sup>1</sup>			
	10-year average, 1910-1919.	1910	1911	1912	1913	1914	1915	1916	1917	1918	1919	10-year average, 1910-1919.	1915	1916	1917	1918	1919	5-year average, 1914-1918.	1919
Mo.	43.5	46.0	44.0	40.0	38.0	46.0	41.0	43.0	37.0	45.0	55.0	120	85	119	228	167	195	57.20	107.25
N. H.	44.6	46.0	45.0	46.0	37.0	46.0	45.0	46.0	40.0	45.0	50.0	112	76	115	217	150	170	55.82	85.00
Vt.	43.3	43.0	41.0	40.0	37.0	47.0	46.0	43.0	45.0	38.0	53.0	113	84	110	213	170	175	56.89	92.75
Mass.	46.8	45.5	44.0	45.0	40.5	47.0	47.0	42.0	45.0	52.0	60.0	116	80	120	215	170	172	62.62	103.20
R. I.	41.0	40.0	45.0	41.5	39.5	42.0	43.0	31.0	42.0	44.0	45.0	130	100	138	236	180	186	61.05	83.70
Conn.	48.9	53.2	48.5	50.0	38.5	46.0	50.0	43.0	50.0	50.0	60.0	117	85	120	215	171	180	65.61	108.00
N. Y.	36.5	38.3	38.5	38.6	28.5	41.0	40.0	30.0	31.0	36.0	43.0	110	78	110	198	175	166	44.52	71.38
N. J.	39.0	36.0	36.8	38.0	39.5	38.5	38.0	40.0	42.0	41.0	40.0	100	75	100	170	150	153	46.13	61.20
Pa.	41.3	41.0	44.5	42.5	39.0	42.5	38.5	39.0	39.0	40.0	47.0	96	70	97	153	155	147	43.49	69.09
Del.	32.8	31.8	34.0	34.0	31.5	36.0	31.5	34.0	34.0	31.0	30.0	86	62	89	140	136	145	32.37	43.50
Md.	36.6	33.5	36.5	36.5	33.0	37.0	35.0	39.0	39.0	35.0	41.0	87	61	89	140	135	140	36.61	57.40
Va.	26.0	25.5	24.0	24.0	26.0	20.5	28.5	28.0	27.0	28.0	28.0	101	71	93	153	160	169	29.80	47.32
W. Va.	30.4	26.0	25.7	33.8	31.0	31.0	31.5	30.5	30.0	31.0	34.0	106	74	101	170	180	164	37.33	55.76
N. C.	19.4	18.6	18.4	18.2	19.5	20.3	21.0	18.5	20.0	21.0	19.0	113	77	110	170	177	185	25.03	35.15
S. C.	17.7	18.5	18.2	17.9	19.5	18.5	16.5	15.5	19.0	17.0	16.0	123	87	113	192	195	197	23.71	31.52
Ga.	15.0	14.5	16.0	13.8	15.5	14.0	15.0	15.5	16.0	15.0	14.5	108	78	100	160	165	160	17.89	23.20
Fla.	14.8	13.0	14.6	13.0	15.0	16.0	15.0	15.0	15.0	16.0	15.0	99	73	90	140	138	140	16.07	21.00
Ohio.	38.6	36.5	38.6	42.8	37.5	39.1	41.5	31.5	38.0	36.0	44.0	81	56	90	136	130	121	34.78	53.24
Ind.	36.3	39.3	36.0	40.3	36.0	33.0	38.0	34.0	36.0	33.0	37.0	76	51	84	125	119	125	30.27	46.25
Ill.	34.2	39.1	33.0	40.0	27.0	29.0	36.0	29.5	38.0	35.5	35.0	76	54	84	110	120	130	29.26	45.50
Mich.	31.9	32.4	33.0	34.0	33.5	36.0	32.0	27.5	21.5	30.0	39.0	92	68	95	182	130	138	30.03	53.82
Wis.	35.4	32.5	36.3	35.7	40.5	40.5	23.0	36.0	22.0	40.2	47.0	87	68	92	163	130	125	32.64	58.75
Minn.	34.2	32.7	33.7	34.5	40.0	35.0	23.0	33.5	30.0	40.0	40.0	72	62	80	110	111	120	27.33	48.00
Iowa.	36.3	36.3	31.0	43.0	34.0	38.0	30.0	36.5	37.0	36.0	41.6	72	51	80	108	122	120	29.86	49.92
Mo.	26.2	33.0	26.0	32.0	17.5	22.0	29.5	19.5	35.0	20.0	27.0	83	57	90	114	143	138	23.57	37.26
N. Dak.	22.4	14.0	25.0	26.7	28.8	28.0	14.0	26.5	9.0	19.0	33.0	84	67	84	151	130	140	17.23	46.20
S. Dak.	27.7	25.0	22.0	30.6	25.5	26.0	29.0	28.5	28.0	34.0	28.5	71	49	77	120	110	119	24.03	33.92
Nebr.	23.7	25.8	21.0	24.0	15.0	24.5	30.0	26.0	27.0	17.7	26.2	74	47	78	120	128	122	20.48	31.96
Kans.	15.5	19.0	14.5	23.0	3.2	18.5	31.0	10.0	13.0	7.1	15.5	84	51	90	125	149	140	12.66	21.70
Ky.	27.1	29.0	26.0	30.4	20.5	25.0	30.0	28.0	31.5	26.0	25.0	88	56	87	121	146	155	26.65	38.75
Tenn.	25.3	25.9	26.8	26.5	20.5	24.0	27.0	26.0	29.0	24.0	23.0	90	58	94	120	145	157	25.20	36.11
Ala.	16.2	18.0	18.0	17.2	17.3	17.0	17.0	12.5	16.0	14.6	14.5	100	69	102	125	148	159	15.94	23.06
Miss.	18.2	20.5	19.0	18.3	20.0	18.5	19.0	14.0	20.5	17.0	15.0	97	65	98	138	151	160	18.71	24.00
La.	19.4	23.6	18.5	18.0	22.0	19.3	20.5	21.0	18.0	16.0	17.5	96	64	94	146	161	150	19.88	26.25
Tex.	18.8	20.6	9.5	21.0	24.0	19.5	23.5	19.0	11.0	10.0	30.0	99	58	104	167	176	118	16.76	35.40
Okla.	14.8	16.0	6.5	18.7	11.0	12.5	29.5	13.5	8.5	7.5	24.0	88	46	93	147	164	127	11.79	30.48
Ark.	19.7	24.0	20.8	20.4	19.0	17.5	23.0	17.7	24.0	13.0	18.0	100	64	98	140	180	164	20.61	29.52
Mont.	23.4	23.0	20.5	25.5	31.5	28.0	28.0	25.0	12.5	21.0	13.5	104	69	93	175	135	165	22.82	22.28
Wyo.	21.0	10.0	15.0	23.0	29.0	25.0	25.0	22.0	20.0	25.0	16.0	99	67	90	175	140	165	24.81	26.40
Colo.	18.6	19.9	14.0	20.8	15.0	23.0	24.0	15.5	20.0	17.5	16.7	87	55	90	125	135	142	17.91	23.71
N. Mex.	23.9	23.0	24.7	22.4	18.5	28.0	26.0	21.0	20.0	25.0	30.0	111	73	113	188	180	151	29.54	45.30
Ariz.	31.2	32.5	33.0	33.0	28.0	32.0	30.0	35.0	27.0	28.0	33.0	139	115	140	190	210	200	46.40	66.00
Utah.	30.2	30.3	35.0	30.0	34.0	35.0	34.0	33.0	25.0	28.0	18.0	108	80	115	170	181	150	36.92	27.00
Nev.	32.2	30.0	30.5	30.0	34.0	36.0	35.0	34.0	30.0	32.0	30.0	123	93	125	150	210	140	45.37	42.00
Idaho.	33.4	32.0	30.0	32.8	32.0	31.0	35.0	35.0	31.0	40.0	35.0	103	65	100	155	183	165	40.26	57.75
Wash.	31.4	28.0	28.5	27.3	28.0	27.0	27.0	37.0	37.0	38.0	36.0	108	77	100	162	170	185	40.41	66.60
Oreg.	30.0	25.5	28.5	31.5	28.5	30.0	35.0	33.5	30.0	31.0	26.2	102	82	95	150	155	155	35.63	40.61
Calif.	35.2	37.5	36.0	37.0	33.0	36.0	41.0	32.0	32.0	35.0	33.0	120	88	124	185	193	179	46.77	59.07
U. S.	26.1	27.7	23.9	29.2	23.1	25.8	28.2	24.4	26.3	24.0	28.6	83.8	57.5	88.9	127.9	136.5	134.9	24.16	38.54

<sup>1</sup> Based upon farm price Dec. 1.

TABLE 8.—Corn: Wholesale price per bushel, 1913-1919.

Date.	New York.			Baltimore.			Cincinnati.			Chicago.			Detroit.			St. Louis.			San Francisco.		
	No. 2 yellow.			Mixed. <sup>1</sup>			No. 2 mixed.			Contract. <sup>2</sup>			No. 3. <sup>3</sup>			No. 2. <sup>3</sup>			White (100 pounds). <sup>4</sup>		
	Low.	High.	Average.	Low.	High.	Average.	Low.	High.	Average.	Low.	High.	Average.	Low.	High.	Average.	Low.	High.	Average.	Low.	High.	Average.
Cts.	Cts.	Cts.	Cts.	Cts.	Cts.	Cts.	Cts.	Cts.	Cts.	Cts.	Cts.	Cts.	Cts.	Cts.	Cts.	Cts.	Cts.	Cts.	Dolls.	Dolls.	Dolls.
1913.																					
January-June.....	55½	66	58.8	52½	65½	57.3	48	65	56.5	46½	63	54.0	48	62	.....	45	64	54.0	1.59	1.80	1.70
July-December.....	79	86	82.9	64½	68	66.0	63½	81	73.2	60	78½	71.0	60½	78½	.....	61½	82	72.6	1.51½	1.87	1.74
1914.																					
January-June.....	60	82½	75.4	66½	77	70.6	64	75	72.9	60	73½	66.4	62	74	67.1	63	73½	68.6	1.61	1.78	1.71
July-December.....	71¾	93¾	82.1	67½	89	79.4	63½	88½	78.3	62½	86	73.4	63½	88	75.0	62¾	87	73.6	1.68	1.93	1.82
1915.																					
January-June.....	77½	90½	84.6	72	84¾	78.7	70	81	76.5	68½	79	74.3	70	80	75.6	68½	78½	74.3	1.72	1.90	1.82
July-December.....	72¾	92¾	82.8	67½	87	77.2	62	84	72.8	59¾	82½	72.0	64	84	74.9	58¾	81	70.4	1.46	1.80	1.68
1916.																					
January-June.....	79½	92¾	86.2	70	84¾	79.6	70½	79	75.7	69	79½	75.2	71½	79½	75.8	69½	77	73.9	1.70	1.80	1.73
July-December.....	88¾	120	101.6	85½	107	96.1	79	107	90.0	78	111	90.4	79½	117	94.0	75½	111	89.4	1.75	2.45	1.88
1917.																					
January-June.....	93½	186	144.2	105	182	140.3	95	176	133.5	93½	176	131.9	102	176½	136.0	94½	175½	131.6	2.05	3.50	2.73
July-December.....	154	245	211.1	140	230	189.8	160	235	198.0	160	236	196.2	181	240	211.3	161	233	192.3	3.35	4.67	3.76
1918.																					
January-June.....	150	221½	181.3	141	195	178.9	140	175	152.2	150	185	168.7	150	215	173.9	148	190	167.9	3.20	3.50	3.40
July-December.....	140	209¾	176.4	150	195	170.1	130	185	155.7	130	180	152.8	135	187	159.5	142	195	159.3	2.75	3.05	2.88
1919.																					
January.....	100	172	156.6	132	165	155.9	126	161	147.0	122	162	142.3	125	158	144.0	127	160	145.9	2.75	3.15	2.93
February.....	142	153	149.5	130	142	138.9	126	145	135.6	122	138	131.7	135	140	137.0	123	140	133.0	2.90	3.15	3.02
March.....	152½	178½	167.9	140	167	152.1	141	163	151.2	131¾	164	149.7	138	173	154.0	135	167	149.9	2.10	2.40	2.24
April.....	173½	189¼	181.4	167	173	169.9	161	169	165.3	155½	172	163.8	163	172	167.5	159	170	162.1	2.15	2.40	2.28
May.....	172½	199¼	189.8	171	182	179.2	164	182	173.8	160½	185	176.6	168	186	177.8	166	180	174.4	2.15	2.45	2.28
June.....	187½	200	194.3	180	192	186.8	176	185	181.0	171	185½	178.8	182	188	183.8	174	185	179.2	2.15	3.30	2.44
January-June..	100	200	173.2	130	192	163.8	126	185	158.9	122	185½	157.2	125	188	160.7	123	185	157.4	2.10	3.35	2.51
July.....	196¾	218¾	211.0	195	215	209.1	183	210	196.7	179½	210	197.6	183	210	198.9	181½	203	195.2	3.20	3.40	3.30
August.....	202¾	226½	214.0	200	215	210.3	200	207	203.5	182	210	197.0	193	210	204.4	188	200	193.5	.....	( <sup>6</sup> )	.....
September.....	154	194½	169.6	.....	( <sup>6</sup> )	.....	136¾	187	161.1	133	183	154.4	146	198	162.6	139	179	157.1	.....	( <sup>6</sup> )	.....
October.....	152½	165½	157.0	.....	( <sup>6</sup> )	.....	143	152	146.2	137	153	144.9	146½	152	149.6	139	149	142.5	3.05	3.35	3.15
November.....	159½	178½	170.0	160	168	164.7	146	153	149.3	137	166	152.8	150	165	157.7	144	159	154.4	3.25	3.50	3.39
December.....	158½	173	181.5	160	172	167.8	148	154	150.8	138	158	147.0	148	155	151.4	150	155	152.6	3.45	3.50	3.48
July-December.	152½	226½	183.8	160	215	188.0	136¾	210	167.9	133	210	165.6	146	210	170.8	139	203	165.9	3.05	3.50	3.33

<sup>1</sup> No. 3 yellow, beginning March, 1919.  
<sup>2</sup> No. 2 mixed, 1919.

<sup>3</sup> No. 3 yellow, 1919.  
<sup>4</sup> California yellow, beginning March, 1919.

<sup>5</sup> No quotations.  
<sup>6</sup> Normal.

<sup>7</sup> Egyptian white.

## CORN—Continued.

TABLE 9.—*Corn: Condition of crop, United States, on first of months named, 1899–1919.*

Year.	July.	Aug.	Sept.	Oct.	Year.	July.	Aug.	Sept.	Oct.	Year.	July.	Aug.	Sept.	Oct.
	<i>P. ct.</i>	<i>P. ct.</i>	<i>P. ct.</i>	<i>P. ct.</i>		<i>P. ct.</i>	<i>P. ct.</i>	<i>P. ct.</i>	<i>P. ct.</i>		<i>P. ct.</i>	<i>P. ct.</i>	<i>P. ct.</i>	<i>P. ct.</i>
1899.....	86.5	89.9	85.2	82.7	1906.....	87.5	88.0	90.2	90.1	1913.....	86.9	75.8	65.1	65.3
1900.....	89.5	87.5	80.6	78.2	1907.....	80.2	82.8	80.2	78.0	1914.....	85.8	74.8	71.7	72.9
1901.....	81.3	54.0	51.7	52.1	1908.....	82.8	82.5	79.4	77.8	1915.....	81.2	79.5	78.8	79.7
1902.....	87.5	86.5	84.3	79.6	1909.....	89.3	84.4	74.6	73.8	1916.....	82.0	75.3	71.3	71.5
1903.....	79.4	78.7	80.1	80.8	1910.....	85.4	79.3	78.2	80.3	1917.....	81.1	78.8	76.7	75.9
1904.....	86.4	87.3	84.6	83.9	1911.....	80.1	69.6	70.3	70.4	1918.....	87.1	78.5	67.4	68.6
1905.....	87.3	89.0	89.5	89.2	1912.....	81.5	80.0	82.1	82.2	1919.....	86.7	81.7	80.0	81.3

TABLE 10.—*Corn: Farm price, cents per bushel, on first of each month, 1910–1919.*

Date.	1919	1918	1917	1916	1915	1914	1913	1912	1911	1910	Average.
Jan. 1.....	144.7	134.8	90.0	62.1	66.2	69.6	48.9	62.2	48.2	62.3	78.9
Feb. 1.....	138.1	138.8	95.8	66.7	72.8	68.3	50.6	64.6	49.0	65.2	81.0
Mar. 1.....	137.2	154.3	100.9	68.2	75.1	69.1	52.2	66.6	48.9	65.9	83.8
Apr. 1.....	149.6	153.6	113.4	70.3	75.1	70.7	53.7	71.1	49.7	65.5	87.3
May 1.....	162.6	155.7	150.6	72.3	77.7	72.1	56.8	79.4	51.8	63.5	94.2
June 1.....	171.2	152.5	160.1	74.1	77.9	75.0	60.6	82.5	55.1	65.2	97.4
July 1.....	176.5	153.7	164.6	75.4	77.7	75.5	63.2	81.1	60.0	66.2	99.4
Aug. 1.....	191.2	159.7	196.6	79.4	78.9	76.8	65.4	79.3	65.8	67.2	106.0
Sept. 1.....	185.4	165.7	175.5	83.6	77.3	81.5	75.4	77.6	65.9	66.3	105.4
Oct. 1.....	153.9	159.5	175.1	82.3	70.5	78.2	75.3	70.2	65.7	61.1	99.2
Nov. 1.....	133.4	140.3	146.0	85.0	61.9	70.6	70.7	58.4	64.7	52.6	88.4
Dec. 1.....	134.9	136.5	127.9	88.9	57.5	64.4	69.1	48.7	61.8	48.0	83.8
Average.....	151.5	147.3	129.2	73.8	71.2	71.4	59.4	67.6	55.3	62.1	88.9

TABLE 11.—*Corn: Monthly marketings by farmers, 1914–1919.*

Month.	Estimated amount sold monthly by farmers of United States (millions of bushels).					Per cent of year's sales.				
	1918-19	1917-18	1916-17	1915-16	1914-15	1918-19	1917-18	1916-17	1915-16	1914-15
July.....	27	34	30	31	19	6.7	5.3	6.2	5.6	3.9
August.....	28	26	34	33	34	6.8	4.0	7.1	5.9	7.1
September.....	35	22	28	35	23	8.4	3.4	5.9	6.4	4.7
October.....	27	24	25	33	23	6.7	3.8	5.3	6.0	4.7
November.....	30	56	67	57	71	7.3	8.8	14.0	10.4	14.7
December.....	49	78	60	88	82	12.1	12.2	12.5	15.9	16.8
January.....	61	91	73	64	96	15.0	14.2	15.1	11.7	19.8
February.....	30	103	43	68	38	7.2	16.1	9.0	12.4	7.8
March.....	31	88	34	39	22	7.5	13.7	7.0	7.1	4.6
April.....	34	45	26	35	27	8.2	7.1	5.4	6.4	5.6
May.....	33	36	31	35	21	8.0	5.6	6.5	6.3	4.4
June.....	25	37	29	32	29	6.1	5.8	6.0	5.9	5.9
Season.....	410	640	480	550	485	100.0	100.0	100.0	100.0	100.0



CORN—Continued.

TABLE 12.—Corn (including meal): International trade, calendar years 1909–1913, 1917, and 1918.

[The item *maicena* or *maizena* is included as "Corn and corn meal."]

GENERAL NOTE.—Substantially the international trade of the world. It should not be expected that the world export and import totals for any year will agree. Among sources of disagreement are these: (1) Different periods of time covered in the "year" of the various countries; (2) imports received in year subsequent to year of export; (3) want of uniformity in classification of goods among countries; (4) different practices and varying degrees of failure in recording countries of origin and ultimate destination; (5) different practices of recording reexported goods; (6) opposite methods of treating free ports; (7) clerical errors, which, it may be assumed, are not infrequent.

The exports given are domestic exports, and the imports given are imports for consumption as far as it is feasible and consistent so to express the facts. While there are some inevitable omissions, on the other hand, there are some duplications because of reshipments that do not appear as such in official reports. For the United Kingdom, import figures refer to imports for consumption, when available, otherwise total imports, less exports, of "foreign and colonial merchandise." Figures for the United States include Alaska, Porto Rico, and Hawaii.

EXPORTS.

[000 omitted.]

Country.	Average 1909-1913	1917 (prelim.)	1918 (prelim.)	Country.	Average 1909-1913	1917 (prelim.)	1918 (prelim.)
<i>From—</i>	<i>Bushels.</i>	<i>Bushels.</i>	<i>Bushels.</i>	<i>From—</i>	<i>Bushels.</i>	<i>Bushels.</i>	<i>Bushels.</i>
Argentina.....	115,749	35,194	26,171	Russia.....	30,034	.....	.....
Austria-Hungary....	268	.....	.....	United States.....	45,054	57,011	47,059
Belgium.....	8,130	.....	.....	Uruguay.....	201	.....	.....
British South Africa.	4,075	11,284	13,508	Other countries...	10,452	.....	.....
Bulgaria.....	9,307	.....	.....	Total.....	270,986	.....	.....
Netherlands.....	8,750	.....	.....				
Roumania.....	38,966	.....	.....				

IMPORTS.

<i>Into—</i>				<i>Into—</i>			
Austria-Hungary....	13,877	.....	.....	Netherlands.....	29,580	.....	.....
Belgium.....	25,801	.....	.....	Norway.....	1,079	1,305	.....
British South Africa.	237	196	56	Portugal.....	1,674	.....	.....
Canada.....	10,629	8,061	11,757	Russia.....	335	.....	.....
Cuba.....	2,746	2,634	1,672	Spain.....	9,775	2,179	383
Denmark.....	11,440	9,508	105	Sweden.....	1,476	1,212	.....
Egypt.....	471	44	5	Switzerland.....	3,987	3,241	652
France.....	18,708	6,349	6,748	United Kingdom..	82,976	53,802	32,275
Germany.....	32,160	.....	.....	Other countries...	4,721	.....	.....
Italy.....	14,895	7,935	10,856	Total.....	270,971	.....	.....
Mexico.....	4,404	.....	.....				

WHEAT.

TABLE 13.—Wheat: Area and production of undermentioned countries, 1909–1919.

[000 omitted.]

Country.	Area.				Production.			
	Average 1909-1913. <sup>1</sup>	1917	1918	1919	Average 1909-1913. <sup>1</sup>	1917	1918	1919
<b>NORTH AMERICA.</b>								
United States.....	<i>Acres.</i> 47,097	<i>Acres.</i> 45,089	<i>Acres.</i> 59,181	<i>Acres.</i> 73,243	<i>Bushels.</i> 686,691	<i>Bushels.</i> 636,655	<i>Bushels.</i> 921,438	<i>Bushels.</i> 940,987
Canada:								
Quebec.....	70	277	366	251	1,168	3,884	6,308	4,394
Ontario.....	850	770	714	981	18,633	16,318	15,241	20,982
Manitoba.....	2,861	2,449	2,984	2,880	53,174	41,040	48,191	43,206
Saskatchewan.....	4,894	8,273	9,249	10,587	97,954	117,921	92,493	97,933
Alberta.....	1,201	2,897	3,892	4,283	24,783	52,992	23,752	26,131
Other.....	69	90	159	149	1,407	1,588	3,090	3,715
Total Canada.....	9,945	14,756	17,364	19,131	197,119	233,743	189,075	196,361
Mexico.....	2,628	( <sup>2</sup> )	( <sup>2</sup> )	( <sup>2</sup> )	9,995	( <sup>2</sup> )	<sup>3</sup> 10,470	( <sup>2</sup> )
<b>Total.....</b>	<b>59,670</b>				<b>893,805</b>		<b>1,120,983</b>	

<sup>1</sup> Five-year average, except in a few cases where statistics for 5 years were not available.

<sup>2</sup> No official statistics.

<sup>3</sup> Unofficial estimate.

## WHEAT—Continued.

TABLE 13.—Wheat: Area and production of undermentioned countries, 1909–1919—Con.  
[000 omitted.]

Country.	Area.				Production.			
	Average 1909–1913.	1917	1918	1919	Average 1909–1913.	1917	1918	1919
SOUTH AMERICA.								
Argentina.....	<i>Acres.</i> 15,799	16,089	17,875	16,976	<i>Bushels.</i> 157,347	80,115	223,636	184,268
Chile.....	1,021	1,272	1,302	1,313	20,316	22,498	23,120	21,591
Uruguay.....	734	780	976	( <sup>1</sup> )	7,314	5,390	13,060	13,044
Total.....	17,554	18,141	20,153	.....	184,977	108,003	259,816	218,903
EUROPE.								
Austria <sup>2</sup> .....	3,011	( <sup>1</sup> )	( <sup>1</sup> )	( <sup>1</sup> )	61,075	( <sup>1</sup> )	( <sup>1</sup> )	( <sup>1</sup> )
Hungary proper <sup>2</sup> .....	8,284	( <sup>1</sup> )	( <sup>1</sup> )	( <sup>1</sup> )	156,523	<sup>3</sup> 115,530	( <sup>1</sup> )	( <sup>1</sup> )
Belgium.....	395	( <sup>1</sup> )	( <sup>1</sup> )	329	14,583	<sup>3</sup> 8,252	<sup>3</sup> 6,189	9,895
Bulgaria <sup>2</sup> .....	2,764	( <sup>1</sup> )	( <sup>1</sup> )	( <sup>1</sup> )	43,725	<sup>3</sup> 38,239	( <sup>1</sup> )	( <sup>1</sup> )
Denmark.....	123	131	140	124	4,916	4,296	6,330	( <sup>1</sup> )
Finland.....	( <sup>1</sup> )	( <sup>1</sup> )	( <sup>1</sup> )	( <sup>1</sup> )	129	( <sup>1</sup> )	( <sup>1</sup> )	( <sup>1</sup> )
France <sup>2</sup> .....	16,308	<sup>4</sup> 10,357	<sup>4</sup> 10,993	11,316	317,254	<sup>4</sup> 134,575	<sup>4</sup> 225,736	177,978
Germany <sup>2</sup> .....	4,768	<sup>5</sup> 3,573	<sup>5</sup> 3,547	( <sup>1</sup> )	152,119	<sup>5</sup> 81,791	<sup>5</sup> 90,330	( <sup>1</sup> )
Greece.....	( <sup>1</sup> )	( <sup>1</sup> )	( <sup>1</sup> )	937	7,200	( <sup>1</sup> )	( <sup>1</sup> )	( <sup>1</sup> )
Italy.....	11,746	10,437	10,798	10,571	183,260	139,999	176,368	169,563
Luxemburg.....	( <sup>1</sup> )	22	24	( <sup>1</sup> )	( <sup>1</sup> )	388	512	( <sup>1</sup> )
Netherlands.....	138	122	148	162	4,976	3,452	5,431	6,015
Norway.....	12	20	41	( <sup>1</sup> )	307	430	1,087	<sup>3</sup> 1,139
Portugal.....	1,180	685	( <sup>1</sup> )	( <sup>1</sup> )	8,683	5,560	<sup>3</sup> 8,252	( <sup>1</sup> )
Roumania.....	<sup>2</sup> 4,576	( <sup>1</sup> )	<sup>6</sup> 5,684	<sup>6</sup> 4,144	<sup>2</sup> 86,679	( <sup>1</sup> )	<sup>6</sup> 18,447	<sup>6</sup> 50,754
Russia proper <sup>2</sup> .....	50,388	( <sup>1</sup> )	( <sup>1</sup> )	( <sup>1</sup> )	522,794	( <sup>1</sup> )	( <sup>1</sup> )	( <sup>1</sup> )
Poland <sup>2</sup> .....	1,260	( <sup>1</sup> )	( <sup>1</sup> )	( <sup>1</sup> )	23,343	( <sup>1</sup> )	( <sup>1</sup> )	( <sup>1</sup> )
Serbia <sup>2</sup> .....	874	( <sup>1</sup> )	( <sup>1</sup> )	( <sup>1</sup> )	14,775	<sup>3</sup> 6,189	<sup>3</sup> 4,126	( <sup>1</sup> )
Spain.....	9,547	10,340	10,228	10,388	130,446	142,674	135,709	133,939
Sweden.....	255	329	381	( <sup>1</sup> )	7,907	6,864	9,003	( <sup>1</sup> )
Switzerland.....	156	139	203	130	3,314	4,556	7,095	3,524
United Kingdom:								
England.....	1,748	1,855	2,461	( <sup>1</sup> )	56,411	57,397	83,957	( <sup>1</sup> )
Wales.....	44	64	96	( <sup>1</sup> )	1,117	1,726	2,938	( <sup>1</sup> )
Scotland.....	52	61	79	80	2,345	2,510	3,317	2,960
Ireland.....	43	124	157	( <sup>1</sup> )	1,608	4,717	5,867	( <sup>1</sup> )
Total, United Kingdom.....	1,887	2,104	2,793	.....	61,481	66,350	96,079	.....
Total.....	117,672	.....	.....	.....	1,805,489	.....	.....	.....
ASIA.								
British India <sup>7</sup> .....	29,114	32,940	35,487	23,764	350,736	382,069	370,421	280,075
Cyprus.....	( <sup>1</sup> )	( <sup>1</sup> )	( <sup>1</sup> )	( <sup>1</sup> )	2,286	<sup>3</sup> 1,524	( <sup>1</sup> )	( <sup>1</sup> )
Japanese Empire:								
Japan.....	1,179	1,393	1,390	1,376	25,274	34,745	32,923	29,800
Formosa.....	14	( <sup>1</sup> )	( <sup>1</sup> )	( <sup>1</sup> )	173	( <sup>1</sup> )	( <sup>1</sup> )	( <sup>1</sup> )
Chosen (Korea).....	( <sup>1</sup> )	( <sup>1</sup> )	( <sup>1</sup> )	( <sup>1</sup> )	( <sup>1</sup> )	( <sup>1</sup> )	6,655	7,144
Persia.....	( <sup>1</sup> )	( <sup>1</sup> )	( <sup>1</sup> )	( <sup>1</sup> )	16,000	( <sup>1</sup> )	( <sup>1</sup> )	( <sup>1</sup> )
Russia:								
Central Asia (4 gov- ernments) <sup>2</sup> .....	3,767	( <sup>1</sup> )	( <sup>1</sup> )	( <sup>1</sup> )	29,292	( <sup>1</sup> )	( <sup>1</sup> )	( <sup>1</sup> )
Siberia (4 gov- ernments) <sup>2</sup> .....	5,987	( <sup>1</sup> )	( <sup>1</sup> )	( <sup>1</sup> )	54,737	( <sup>1</sup> )	( <sup>1</sup> )	( <sup>1</sup> )
Trauscaucasia (1 gov- ernment) <sup>2</sup> .....	10	( <sup>1</sup> )	( <sup>1</sup> )	( <sup>1</sup> )	110	( <sup>1</sup> )	( <sup>1</sup> )	( <sup>1</sup> )
Total, Russia, Asiatic.....	9,764	.....	.....	.....	84,139	.....	.....	.....
Turkey (Asiatic).....	( <sup>1</sup> )	( <sup>1</sup> )	( <sup>1</sup> )	( <sup>1</sup> )	35,000	( <sup>1</sup> )	( <sup>1</sup> )	( <sup>1</sup> )
Total.....	40,071	.....	.....	.....	513,608	.....	.....	.....
AFRICA.								
Algeria.....	3,371	3,222	3,186	2,828	33,071	23,151	49,774	25,559
Egypt.....	1,311	1,116	1,286	1,323	34,000	29,834	32,555	( <sup>1</sup> )
Tunis.....	1,193	1,310	1,413	1,190	6,063	6,963	8,451	7,349
Union of South Africa.....	( <sup>1</sup> )	755	925	953	4,620	4,790	8,833	8,600
Total.....	5,875	6,403	6,810	6,294	77,754	64,738	99,613	.....

<sup>1</sup> No official statistics.<sup>2</sup> Old boundaries.<sup>3</sup> Unofficial estimate.<sup>4</sup> Excludes territory occupied by the enemy.<sup>5</sup> Excludes Alsace-Lorraine.<sup>6</sup> Excluding Dobrudja.<sup>7</sup> Including some native States.

WHEAT—Continued.

TABLE 13.—Wheat: Area and production of undermentioned countries, 1909–1919—Con.  
[000 omitted.]

Country.	Area.				Production.			
	Average 1909–1913.	1917	1918	1919	Average 1909–1913.	1917	1918	1919
AUSTRALASIA.								
Australia:	<i>Acres.</i>	<i>Acres.</i>	<i>Acres.</i>	<i>Acres.</i>	<i>Bushels.</i>	<i>Bushels.</i>	<i>Bushels.</i>	<i>Bushels.</i>
Queensland.....	95	228	128	22	1,250	2,463	1,035	105
New South Wales....	2,025	3,807	3,329	2,411	26,717	36,598	37,712	17,833
Victoria.....	2,105	3,126	2,690	2,214	27,656	51,162	37,738	25,240
South Australia.....	1,993	2,778	2,356	2,134	22,843	45,745	28,693	22,937
Western Australia....	544	1,567	1,250	1,145	5,671	16,103	9,304	8,837
Tasmania.....	36	28	22	12	806	348	252	187
Other.....	(1)	1	(1)	52	(1)	14	(1)	(1)
Total, Australia....	6,798	11,535	9,775	7,990	84,943	152,433	114,734	75,139
New Zealand.....	258	218	281	209	7,885	5,051	6,808	6,659
Total, Australasia..	7,056	11,753	10,056	8,199	92,828	157,484	121,542	81,798
Grand total.....	247,898	.....	.....	.....	3,568,461	.....	.....	.....

<sup>1</sup> No official statistics.

TABLE 14.—Wheat: Total production of countries named in Table 13, 1891–1916.

Year.	Production.	Year.	Production.	Year.	Production.	Year.	Production.
	<i>Bushels.</i>		<i>Bushels.</i>		<i>Bushels.</i>		<i>Bushels.</i>
1891.....	2,432,322,000	1898.....	2,948,305,000	1905.....	3,327,084,000	1912.....	3,791,951,000
1892.....	2,481,805,000	1899.....	2,783,885,000	1906.....	3,434,354,000	1913.....	4,127,437,000
1893.....	2,559,174,000	1900.....	2,610,751,000	1907.....	3,133,965,000	1914.....	3,585,916,000
1894.....	2,660,557,000	1901.....	2,955,975,000	1908.....	3,182,105,000	1915.....	4,127,685,000
1895.....	2,593,312,000	1902.....	3,090,116,000	1909.....	3,581,519,000	1916.....	3,701,333,000
1896.....	2,506,320,000	1903.....	3,189,813,000	1910.....	3,575,055,000		
1897.....	2,236,268,000	1904.....	3,163,542,000	1911.....	3,551,795,000		

TABLE 15.—Wheat: Average yield per acre in undermentioned countries, 1890–1919.

Year.	United States.	Russia (European). <sup>1</sup>	Germany. <sup>1</sup>	Austria. <sup>1</sup>	Hungary proper. <sup>1</sup>	France. <sup>2</sup>	United Kingdom. <sup>2</sup>
Average:	<i>Bushels.</i>	<i>Bushels.</i>	<i>Bushels.</i>	<i>Bushels.</i>	<i>Bushels.</i>	<i>Bushels.</i>	<i>Bushels.</i>
1890–1899.....	13.2	8.9	24.5	16.2	.....	18.6	31.2
1900–1909.....	14.1	9.7	28.9	18.0	17.5	20.5	33.1
1910–1914.....	14.8	10.3	31.7	20.8	18.6	19.1	32.4
1906.....	15.5	7.7	30.3	20.3	22.5	20.2	34.8
1907.....	14.0	8.0	29.6	18.0	14.9	23.2	35.1
1908.....	14.0	8.8	29.7	21.0	17.5	19.6	33.4
1909.....	15.4	12.5	30.5	19.9	14.1	22.0	35.0
1910.....	13.9	11.2	29.6	19.2	19.8	15.9	31.4
1911.....	12.5	7.0	30.6	19.6	20.9	19.8	34.0
1912.....	15.9	10.3	33.6	22.3	19.8	21.0	30.0
1913.....	15.2	13.5	35.1	19.9	19.6	19.9	32.7
1914.....	16.6	9.4	29.6	22.9	13.1	18.9	33.8
1915.....	17.0	11.6	28.6	17.8	18.4	16.6	32.7
1916.....	12.2	.....	.....	.....	.....	16.5	30.0
1917.....	14.1	.....	.....	.....	.....	<sup>1</sup> 13.8	31.5
1918.....	15.5	.....	.....	.....	.....	21.6	34.3
1919.....	12.8	.....	.....	.....	.....	.....	.....

<sup>1</sup> Bushels of 60 pounds.

<sup>2</sup> Winchester bushels.

## WHEAT—Continued.

TABLE 16.—Wheat: Acreage, production, value, exports, etc., in the United States, 1849-1919.

NOTE.—Figure in *italics* are census returns; figures in roman are estimates of the Department of Agriculture. Estimates of acres are obtained by applying estimated percentages of increase or decrease to the published numbers of the preceding year, except that a revised base is used for applying percentage estimates whenever new census data are available.

Year.	Acreage harvested.	Average yield per acre.	Production.	Average farm price per bushel Dec. 1.	Farm value Dec. 1.	Chicago cash price per bushel, No. 1 northern spring.				Domestic exports including flour, fiscal year beginning July 1.	Per cent of crop exported.
						December.		Following May.			
						Low.	High.	Low.	High.		
	<i>Acres.</i>	<i>Bush.</i>	<i>Bushels.</i>	<i>Cents.</i>	<i>Dollars.</i>	<i>Cts.</i>	<i>Cts.</i>	<i>Cts.</i>	<i>Cts.</i>	<i>Bushels.</i>	<i>P.ct.</i>
1849			100,486,000							7,535,901	7.5
1859			173,105,000							17,213,130	9.9
1866	15,424,000	9.9	152,000,000	152.7	232,110,000	129	145	185	211	12,646,941	8.3
1867	18,322,000	11.6	212,441,000	145.2	308,387,000	126	140	134	161	26,323,014	12.4
1868	18,460,000	12.1	224,037,000	108.5	243,033,000	80	88	87	96	29,717,201	13.3
1869	19,181,000	13.6	260,147,000	76.5	199,025,000	63	76	79	92	53,900,780	20.7
1869			287,746,000								
1870	18,993,000	12.4	235,885,000	94.4	222,767,000	91	98	113	120	52,574,111	22.3
1871	19,944,000	11.6	230,722,000	114.5	264,076,000	107	111	120	143	38,995,755	16.9
1872	20,858,000	12.0	249,997,000	111.4	278,522,000	97	108	112	122	52,014,715	20.8
1873	22,172,000	12.7	281,255,000	106.9	300,670,000	96	106	105	114	91,510,398	32.5
1874	24,967,000	12.3	308,103,000	86.3	265,881,000	78	83	78	94	72,912,817	23.7
1875	26,382,000	11.1	292,136,000	89.5	261,397,000	82	91	89	100	74,750,682	25.6
1876	27,627,000	10.5	289,356,000	97.0	280,743,000	104	117	130	172	57,043,936	19.7
1877	26,278,000	13.9	364,194,000	105.7	385,089,000	103	108	98	113	92,141,626	25.3
1878	32,109,000	13.1	420,122,000	77.6	325,814,000	81	84	91	102	150,502,506	35.8
1879	32,546,000	13.8	448,757,000	110.8	497,030,000	122	133½	112½	119	180,304,181	40.2
1879	35,430,000	13.0	459,483,000								
1880	37,987,000	13.1	498,550,000	95.1	474,202,000	93½	109½	101	112½	186,321,514	37.4
1881	37,709,000	10.2	383,280,000	119.2	456,880,000	124½	129	123	140	121,892,389	31.8
1882	37,067,000	13.6	504,185,000	88.4	445,602,000	91½	94½	108	113½	147,811,316	29.3
1883	36,456,000	11.6	421,086,000	91.1	383,649,000	94½	99½	85	94½	111,534,182	26.5
1884	39,476,000	13.0	512,765,000	64.5	330,862,000	69½	76½	85½	90½	132,570,366	25.9
1885	34,189,000	10.4	357,112,000	77.1	275,320,000	82½	89	72½	79	94,565,793	26.5
1886	36,806,000	12.4	457,218,000	68.7	314,226,000	75½	79½	80½	88½	153,804,969	33.6
1887	37,642,000	12.1	456,329,000	68.1	310,613,000	75½	79½	81½	89½	119,625,344	26.2
1888	37,336,000	11.1	415,868,000	92.6	385,248,000	96½	105½	77½	95½	88,600,743	21.3
1889	38,124,000	12.9	490,560,000	69.8	342,492,000	76½	80½	89½	100	109,430,467	22.3
1889	33,580,000	13.9	468,374,000								
1890	36,087,000	11.1	399,262,000	83.8	334,774,000	87½	92½	98½	108½	106,181,316	26.6
1891	39,917,000	15.3	611,781,000	83.9	513,473,000	89½	93½	80	85½	225,665,811	36.9
1892	38,554,000	13.4	515,947,000	62.4	322,112,000	69½	73	68½	76½	191,912,635	37.2
1893	34,629,000	11.4	396,132,000	53.8	213,171,000	59½	64½	52½	60½	164,283,129	41.5
1894	34,882,000	13.2	460,267,000	49.1	225,902,000	52½	63½	60½	85½	144,812,718	31.5
1895	34,047,000	13.7	467,103,000	50.9	237,939,000	53½	64½	57½	67½	126,443,968	27.1
1896	34,619,000	12.4	427,684,000	72.6	310,598,000	74½	93½	68½	97½	145,124,972	33.9
1897	39,465,000	13.4	530,149,000	80.8	428,547,000	92	109	117	185	217,306,005	41.0
1898	44,055,000	15.3	675,149,000	58.2	392,770,000	62½	70	68½	79½	222,618,420	33.0
1899	44,593,000	12.3	547,304,000	58.4	319,545,000	64	69½	63½	67½	186,096,762	34.0
1899	52,589,000	12.5	658,534,000								
1900	42,495,000	12.3	522,230,000	61.9	323,515,000	69½	74½	70	75½	215,990,073	41.4
1901	49,896,000	15.0	748,460,000	62.4	467,360,000	73	79½	72½	76½	234,772,516	31.4
1902	46,202,000	14.5	670,063,000	63.0	422,224,000	71½	77½	74½	80½	202,905,598	30.3
1903	49,465,000	12.9	637,822,000	69.5	443,025,000	77½	87	87½	101½	120,727,613	18.9
1904	44,075,000	12.5	552,400,000	92.4	510,490,000	115	122	89½	113½	44,112,910	8.0
1905	47,854,000	14.5	692,979,000	74.8	518,373,000	82½	90	80½	87½	97,609,007	14.1
1906	47,306,000	15.5	735,261,000	66.7	490,333,000			84	106	146,700,425	20.0
1907	45,211,000	14.0	634,087,000	87.4	554,437,000					163,043,669	25.7
1908	47,557,000	14.0	664,602,000	92.8	616,826,000	106½	112	126½	137	114,268,468	17.2
1909	46,723,000	15.8	737,189,000								
1909	44,262,000	15.4	683,379,000	98.6	668,680,000	106	119½	100	119½	87,364,318	12.8
1910 <sup>1</sup>	45,681,000	13.9	635,121,000	88.3	561,051,000	104	110	98	106	69,311,760	10.9
1911	49,543,000	12.5	621,338,000	87.4	543,063,000	105	110	115	122	79,689,404	12.8
1912	45,814,000	15.9	730,267,000	76.0	555,280,000	85	90½	90½	96	142,879,596	19.6
1913	50,184,000	15.2	763,380,000	79.9	610,122,000	89½	93	96	100	145,590,349	19.1
1914	53,541,000	16.6	891,017,000	98.6	878,680,000	115	131	141	164½	332,464,975	37.3
1915	60,469,000	17.0	1,025,801,000	91.9	942,303,000	106	128½	116	126	243,117,026	23.7
1916	52,316,000	12.2	636,318,000	160.3	1,019,968,000	155½	190	258	340	203,573,928	32.0
1917	45,089,000	14.1	636,655,000	200.8	1,278,112,000	220	220	220	220	132,578,633	20.8
1918	59,181,000	15.6	921,438,000	204.2	1,881,826,000	220	220	245	280	287,438,087	31.2
1919	73,243,000	12.8	940,987,000	215.1	2,024,008,000	280	325				

<sup>1</sup> Figures adjusted to census basis.

WHEAT—Continued.

TABLE 17.—Wheat: Revised acreage, production, and farm value, 1879, and 1889–1909.

[See head note of Table 4.]

Year.	Acreage harvested.	Average yield per acre.	Production.	Average farm price per bushel Dec. 1.	Farm value Dec. 1.
	<i>Acres.</i>	<i>Bushels.</i>	<i>Bushels.</i>	<i>Cents.</i>	<i>Dollars.</i>
1879.....	55,430,000	14.1	496,435,000	110.6	549,219,000
1889.....	33,580,000	12.9	434,383,000	69.5	301,869,000
1890.....	34,048,000	11.1	378,097,000	83.3	315,112,000
1891.....	37,826,000	15.5	584,504,000	83.4	487,463,000
1892.....	39,552,000	13.3	527,986,000	62.2	328,329,000
1893.....	37,934,000	11.3	427,553,000	53.5	228,599,000
1894.....	39,425,000	13.1	516,485,000	48.9	252,709,000
1895.....	40,848,000	13.9	569,456,000	50.3	286,539,000
1896.....	43,916,000	12.4	544,193,000	71.7	390,346,000
1897.....	46,046,000	13.3	610,254,000	80.9	493,683,000
1898.....	51,007,000	15.1	772,163,000	58.2	449,022,000
1899.....	52,589,000	12.1	636,051,000	58.6	372,982,000
1900.....	51,387,000	11.7	602,708,000	62.0	373,578,000
1901.....	52,473,000	15.0	789,538,000	62.6	494,096,000
1902.....	49,649,000	14.6	724,528,000	63.0	456,530,000
1903.....	51,632,000	12.9	664,543,000	69.5	461,605,000
1904.....	47,825,000	12.5	596,375,000	92.4	551,128,000
1905.....	49,389,000	14.7	726,384,000	74.6	542,119,000
1906.....	47,800,000	15.8	757,195,000	66.2	501,355,000
1907.....	45,116,000	14.1	637,981,000	86.5	552,074,000
1908.....	45,970,000	14.0	644,656,000	92.2	594,092,000
1909.....	44,262,000	15.8	700,434,000	98.4	689,108,000

TABLE 18.—Winter and spring wheat: Acreage (sown and harvested), production, and farm value Dec. 1, by States in 1919, and United States totals, 1890–1918.

[000 omitted, except in yield and price columns.]

State.	Winter wheat.						Spring wheat.				
	Acreage sown in preceding fall.	Acreage harvested.	Average yield per acre.	Production.	Average farm price Dec. 1.	Total farm value Dec. 1.	Acreage.	Average yield per acre.	Production.	Average farm price Dec. 1.	Total farm value Dec. 1.
	<i>Acres.</i>	<i>Acres.</i>	<i>Bush.</i>	<i>Bush.</i>	<i>Cts.</i>	<i>Dollars.</i>	<i>Acres.</i>	<i>Bush.</i>	<i>Bush.</i>	<i>Cts.</i>	<i>Dollars.</i>
Me.....							12	19.0	228	220	502
Vt.....							12	21.0	252	227	572
N. Y.....	477	474	22.0	10,428	215	22,420	50	15.0	750	215	1,612
N. J.....	111	109	18.0	1,962	220	4,316					
Pa.....	1,646	1,638	17.5	28,665	216	61,916	26	15.0	390	216	842
Del.....	145	145	12.0	1,740	213	3,706					
Md.....	794	790	13.5	10,665	215	22,930					
Va.....	1,071	1,060	11.8	12,508	224	28,018					
W. Va.....	402	400	13.5	5,400	220	11,880					
N. C.....	859	850	8.5	7,225	233	16,834					
S. C.....	208	204	9.0	1,836	258	4,737					
Ga.....	255	240	10.5	2,520	263	6,628					
Ohio.....	2,814	2,800	19.1	53,480	212	113,378	60	16.0	960	212	2,035
Ind.....	2,882	2,862	16.0	45,792	210	96,163	24	9.5	228	210	479
Ill.....	3,434	3,400	17.0	57,800	210	121,380	750	10.5	7,875	210	16,538
Mich.....	960	950	20.3	19,285	210	40,498	85	11.2	952	210	1,999
Wis.....	78	76	19.6	1,490	215	3,204	473	12.4	5,865	215	12,610
Minn.....	67	65	15.0	975	250	2,438	3,950	9.3	36,735	250	91,838
Iowa.....	954	950	17.4	16,530	200	33,060	750	9.5	7,145	200	14,290
Mo.....	4,300	4,274	13.5	57,699	209	120,591	22	8.5	187	209	391

## WHEAT—Continued.

TABLE 18.—Winter and spring wheat: Average (sown and harvested), production, and farm value Dec. 1, by States in 1919, and United States totals, 1890-1918.

State and year.	Winter wheat.						Spring wheat.				
	Acreage sown in preceding fall.	Acreage harvested.	Average yield per acre.	Production.	Average farm price Dec. 1.	Total farm value Dec. 1.	Acreage.	Average yield per acre.	Production.	Average farm price Dec. 1.	Total farm value Dec. 1.
	Acres.	Acres.	Bush.	Bush.	Cts.	Dollars.	Acres.	Bush.	Bush.	Cts.	Dollars.
N. Dak.							7,770	6.9	53,613	241	129,207
S. Dak.	79	75	13.0	975	240	2,340	3,650	8.0	29,200	240	70,080
Nebr.	3,727	3,716	14.8	54,997	202	111,094	668	8.5	5,678	202	11,470
Kans.	11,641	11,594	13.0	150,722	215	324,052	30	9.3	279	215	600
Ky.	1,057	1,046	11.5	12,029	211	25,381					
Tenn.	822	810	9.0	7,290	222	16,184					
Ala.	141	138	9.0	1,242	245	3,043					
Miss.	38	36	14.0	504	250	1,260					
Tex.	1,959	1,900	16.5	31,350	200	62,700					
Okla.	3,798	3,760	14.0	52,640	205	107,912					
Ark.	346	340	9.5	3,230	202	6,525					
Mont.	607	580	5.2	3,016	235	7,088	1,641	4.7	7,713	235	18,126
Wyo.	88	84	12.0	1,008	212	2,137	200	15.0	3,000	212	6,360
Colo.	1,075	1,064	11.2	11,917	202	24,072	395	14.5	5,728	202	11,511
N. Mex.	182	173	20.0	3,460	200	6,920	110	24.0	2,640	200	5,280
Ariz.	45	43	28.0	1,204	225	2,709					
Utah.	172	164	10.5	1,722	210	3,616	140	14.0	1,960	210	4,116
Nev.	4	4	20.0	80	214	171	25	23.5	588	214	1,258
Idaho.	337	330	18.5	6,105	205	12,515	700	18.0	12,600	205	25,830
Wash.	1,021	990	20.0	19,800	214	42,372	1,450	14.0	20,300	214	43,442
Oreg.	793	781	20.5	16,010	212	33,941	345	13.0	4,485	212	9,508
Calif.	1,100	990	16.5	16,335	204	33,323					
U. S.	50,489	49,905	14.7	731,636	211.0	1,543,452	23,338	9.0	209,351	229.5	480,556
1918.	42,301	37,130	15.2	565,099	206.3	1,165,995	22,051	16.2	356,339	200.9	715,831
1917.	40,534	27,257	15.1	412,901	202.8	837,237	17,832	12.5	223,754	197.0	440,875
1916.	39,203	34,709	13.8	480,553	162.7	781,906	17,607	8.8	155,765	152.8	238,062
1915.	42,881	41,308	16.3	673,947	94.7	638,149	19,161	18.4	351,854	86.4	304,154
1914.	37,128	36,008	19.0	684,990	98.6	675,623	17,533	11.8	206,027	98.6	203,057
1913.	33,618	31,699	16.5	523,561	82.9	433,995	18,485	13.0	239,819	73.4	176,127
1912.	33,215	26,571	15.1	399,919	80.9	323,572	19,243	17.2	330,348	70.1	231,708
1911.	32,648	29,162	14.8	430,656	88.0	379,151	20,381	9.4	190,682	86.0	163,912
1910.	31,656	27,329	15.9	434,142	88.1	382,318	18,352	11.0	200,979	88.9	178,783
1909 <sup>1</sup> .	29,301	27,151	15.5	419,733	102.4	426,184	17,111	15.4	263,646	92.5	242,496
1908.	31,646	30,349	14.4	437,908	93.7	410,330	17,208	13.2	226,694	91.1	206,496
1907.	31,665	28,132	14.6	409,442	88.2	361,217	17,079	13.2	224,645	86.0	193,220
1906.	31,312	29,600	16.7	492,888	68.3	336,435	17,706	13.7	242,373	63.5	153,898
1905.	31,155	29,864	14.3	428,463	78.2	334,987	17,990	14.7	264,517	69.3	183,386
1904.	31,654	26,866	12.4	332,935	97.8	325,611	17,209	12.8	219,464	84.2	184,879
1903.	34,071	32,511	12.3	399,867	71.6	286,243	16,954	14.0	237,955	65.9	156,782
1902.	32,432	28,581	14.4	411,789	64.8	266,727	17,621	14.7	258,274	60.2	155,497
1901.	30,283	30,240	15.2	458,835	66.1	303,227	19,656	14.7	289,626	56.7	164,133
1900.	30,883	26,236	13.3	350,025	63.3	221,668	16,259	10.6	172,204	59.1	101,847
1899.	29,954	25,358	11.5	291,706	63.0	183,767	19,235	13.3	255,598	53.1	135,778
1898.	27,642	25,745	14.9	382,492	62.2	237,736	18,310	16.0	292,657	53.0	155,034
1897.	24,765	22,926	14.1	323,616	85.1	275,323	16,539	12.5	206,533	74.2	153,224
1896.	23,383	22,794	11.8	267,934	77.0	206,270	11,825	13.5	159,750	65.3	104,328
1895.	24,224	22,609	11.6	261,242	57.8	150,944	11,438	18.0	205,861	42.3	86,995
1894.	21,553	23,519	14.0	329,290	49.8	164,022	11,364	11.5	130,977	47.2	61,880
1893.		23,118	12.0	278,469	56.3	156,720	11,511	10.2	117,662	48.0	56,451
1892.		26,209	13.7	359,416	65.1	234,037	12,345	12.7	156,531	56.3	88,075
1891.		27,524	14.7	405,116	88.0	356,415	12,393	16.7	206,665	76.0	157,058
1890.	24,359	23,520	10.9	255,374	87.5	223,362	12,567	11.4	143,890	77.4	111,411

<sup>1</sup> Census acreage and production.

WHEAT—Continued.

TABLE 19.—Winter and spring wheat: Yield per acre, in States producing both, for 10 years.

WINTER WHEAT.

State.	Yield per acre (bushels).										
	10-year aver., 1910-1919.	1910	1911	1912	1913	1914	1915	1916	1917	1918	1919
New York.....									21.0	18.0	22.0
Ohio.....									22.0	19.0	19.1
Indiana.....									18.5	21.0	16.0
Illinois.....									18.5	21.5	17.0
Michigan.....									18.0	14.0	20.3
Wisconsin.....	20.5	20.0	17.5	19.5	20.1	21.5	23.0	19.0	24.0	21.2	19.6
Minnesota.....	17.2				16.2	19.5	19.5	14.0	18.0	18.0	15.0
Iowa.....	20.4	21.2	19.7	23.0	23.4	21.6	21.5	18.5	17.5	20.5	17.4
Missouri.....									15.3	17.2	13.5
South Dakota.....	15.1				9.0	14.0	20.5	18.5	14.0	17.0	13.0
Nebraska.....	16.3	16.5	13.8	18.0	18.6	19.3	18.5	20.0	12.0	11.1	14.8
Kansas.....	13.8	14.2	10.8	15.5	13.0	20.5	12.5	12.0	12.2	14.1	13.0
Montana.....	20.6	22.0	31.7	24.5	25.6	23.0	27.0	21.5	13.0	12.7	5.2
Wyoming.....	23.1	25.0	26.0	28.0	25.0	24.0	26.0	21.0	20.0	24.0	12.0
Colorado.....	20.2	23.0	18.0	24.5	21.1	25.0	26.0	20.0	23.0	10.5	11.2
New Mexico.....	18.7	20.0	25.0	20.0	18.6	25.0	22.0	16.5	10.0	10.0	20.0
Utah.....	19.9	20.5	20.0	24.0	23.0	25.0	25.0	20.0	14.0	16.6	10.5
Nevada.....	25.2	24.0	23.0	27.5	23.0	29.0	26.0	24.5	26.0	29.0	20.0
Idaho.....	25.0	23.7	31.5	28.7	27.4	27.5	29.0	24.0	18.0	22.0	18.5
Washington.....	24.8	20.5	27.3	27.6	27.0	26.5	27.6	26.5	21.5	23.5	20.0
Oregon.....	21.8	23.7	22.2	26.8	21.4	22.0	24.0	23.0	17.5	17.0	20.5
United States.....	15.6	15.9	14.8	15.1	16.5	19.0	16.3	13.8	15.1	15.2	14.7

SPRING WHEAT.

New York.....									21.0	20.0	15.0
Pennsylvania.....										17.0	15.0
Ohio.....										21.5	16.0
Indiana.....									20.0	23.0	9.5
Illinois.....									25.0	26.9	10.5
Michigan.....									17.7	18.0	11.2
Wisconsin.....	18.5	18.7	14.5	18.5	18.6	17.0	22.5	16.6	21.2	24.7	12.4
Minnesota.....	14.1	16.0	10.1	15.5	16.2	10.5	17.0	7.5	17.5	21.0	9.3
Iowa.....	16.1	20.9	13.8	17.0	17.0	13.5	16.7	13.0	21.5	18.0	9.5
Missouri.....									9.0	15.6	8.5
South Dakota.....	11.3	12.8	4.0	14.2	9.0	9.0	17.0	6.3	14.0	19.0	8.0
Nebraska.....	12.7	13.9	10.0	14.1	12.0	11.5	16.0	12.5	16.5	11.9	8.5
Kansas.....	9.7	8.4	4.2	15.0	8.5	15.0	12.0	10.5	6.0	8.0	9.3
Montana.....	17.9	22.0	25.2	23.5	21.5	17.0	26.0	18.0	9.0	12.5	4.7
Wyoming.....	23.9	25.0	26.0	29.2	25.0	22.0	27.0	22.0	22.0	26.0	15.0
Colorado.....	20.3	21.9	19.5	24.0	21.0	22.5	21.0	19.5	22.0	17.5	14.5
New Mexico.....	21.4	20.0	20.5	22.0	19.0	23.0	22.5	21.5	18.0	24.0	24.0
Utah.....	25.0	25.3	27.0	29.2	28.0	25.0	28.0	25.0	25.0	23.8	14.0
Nevada.....	29.3	29.0	32.5	30.2	31.0	30.0	32.0	31.5	28.0	25.0	23.5
Idaho.....	24.1	20.4	29.0	28.3	28.0	24.0	26.5	23.5	22.0	21.0	18.0
Washington.....	17.4	14.5	19.5	20.4	19.0	20.0	22.2	21.5	13.6	9.5	14.0
Oregon.....	16.6	18.0	17.7	19.5	19.5	16.5	17.0	23.0	11.0	11.0	13.0
United States.....	12.7	11.0	9.4	17.2	13.0	11.8	18.4	8.8	12.5	16.2	9.0

## WHEAT—Continued.

TABLE 20.—Wheat: Acreage, production, and total farm value, by States, 1918 and 1919.

State.	Thousands of acres.		Production (thousands of bushels).		Total value, basis Dec. 1 price (thousands of dollars).	
	1919	1918	1919	1918	1919	1918
Maine.....	12	22	228	484	502	1,147
Vermont.....	12	19	252	418	572	966
New York.....	524	439	11,178	7,840	24,032	16,856
New Jersey.....	109	87	1,962	1,479	4,316	3,180
Pennsylvania.....	1,664	1,503	29,055	25,551	62,758	54,679
Delaware.....	145	133	1,740	1,729	3,706	3,838
Maryland.....	790	732	10,665	11,346	22,930	24,848
Virginia.....	1,060	1,050	12,508	12,600	28,018	27,594
West Virginia.....	400	348	5,400	4,942	11,880	10,922
North Carolina.....	850	900	7,225	6,300	16,834	14,490
South Carolina.....	204	205	1,836	2,255	4,737	5,863
Georgia.....	240	280	2,520	2,856	6,628	7,597
Ohio.....	2,860	2,290	54,440	43,547	115,413	92,320
Indiana.....	2,886	2,353	46,020	49,427	96,642	102,808
Illinois.....	4,150	2,900	65,675	63,970	137,918	133,058
Michigan.....	1,035	762	20,237	10,856	42,497	22,689
Wisconsin.....	549	424	7,355	10,273	15,814	21,059
Minnesota.....	4,015	3,619	37,710	75,792	94,276	154,616
Iowa.....	1,700	1,240	23,675	23,382	47,350	46,764
Missouri.....	4,296	3,092	57,886	53,154	120,982	108,966
North Dakota.....	7,770	7,770	53,613	105,672	129,207	214,514
South Dakota.....	3,725	3,280	30,175	62,160	72,420	123,698
Nebraska.....	4,384	3,666	60,675	41,213	122,564	81,190
Kansas.....	11,624	7,248	151,001	102,008	324,652	202,996
Kentucky.....	1,046	933	12,029	12,129	25,381	25,956
Tennessee.....	810	750	7,290	7,500	16,184	16,050
Alabama.....	138	162	1,242	1,458	3,043	3,572
Mississippi.....	36	30	504	495	1,260	1,238
Texas.....	1,900	900	31,350	9,000	62,700	19,350
Oklahoma.....	3,760	2,611	52,640	32,899	107,912	66,127
Arkansas.....	340	254	3,230	3,048	6,525	6,309
Montana.....	2,221	2,386	10,729	29,961	25,214	58,124
Wyoming.....	284	260	4,008	6,600	8,497	12,474
Colorado.....	1,459	1,250	17,645	15,400	35,643	30,030
New Mexico.....	283	173	6,100	2,892	12,200	6,073
Arizona.....	43	38	1,204	988	2,709	2,371
Utah.....	304	320	3,682	6,464	7,732	12,152
Nevada.....	29	42	668	1,070	1,429	2,205
Idaho.....	1,030	950	18,705	20,275	38,345	38,928
Washington.....	2,440	2,225	40,100	29,187	85,814	57,207
Oregon.....	1,126	1,038	20,495	15,228	43,449	30,608
California.....	990	506	16,335	7,590	33,323	16,394
United States.....	73,243	59,181	940,987	921,438	2,024,008	1,881,826



WHEAT—Continued.

TABLE 21.—Wheat: Production and distribution in the United States, 1897–1919.

[000 omitted, except in weight and quality columns.]

Year.	Old stock on farms July 1.	Crop.			Total supplies.	Stock on farms Mar. 1 following.	Shipped out of county where grown.
		Quantity.	Weight per bushel.	Quality.			
	<i>Bushels.</i>	<i>Bushels.</i>	<i>Pounds.</i>	<i>Per cent.</i>	<i>Bushels.</i>	<i>Bushels.</i>	<i>Bushels.</i>
1897	23,347	530,149	57.1	.....	553,496	121,320	269,126
1898	17,839	675,149	57.7	87.9	692,988	198,056	398,882
1899	64,061	547,304	56.9	83.7	611,365	158,746	305,020
1900	50,900	522,230	56.3	87.8	573,130	128,098	281,372
1901	30,552	748,460	57.5	88.8	779,012	173,353	372,717
1902	52,437	670,063	57.6	.....	722,500	164,047	388,554
1903	42,540	637,822	57.3	.....	680,362	132,608	369,582
1904	36,634	552,400	57.4	.....	589,034	111,055	302,771
1905	24,257	692,979	55.5	.....	717,236	158,403	404,092
1906	46,053	735,261	58.3	.....	781,314	206,642	427,253
1907	54,853	634,087	58.2	89.9	688,940	148,721	367,607
1908	33,797	664,602	58.3	89.4	698,399	143,692	393,435
1909	15,062	683,379	57.9	90.4	698,441	159,100	414,166
1910	35,680	635,121	58.5	93.1	670,801	162,705	352,906
1911	34,071	621,338	57.8	88.3	655,409	122,041	348,739
1912	23,876	730,267	58.3	90.0	754,143	156,471	449,881
1913	35,515	763,380	58.7	93.2	798,895	151,795	411,733
1914	32,236	891,017	58.0	89.7	923,253	152,903	541,193
1915	28,972	1,025,801	57.9	88.4	1,054,773	244,448	633,380
1916	74,731	636,318	57.1	87.0	711,049	100,650	361,088
1917	15,611	636,655	58.5	92.4	652,266	107,745	325,500
1918	8,063	921,438	58.8	93.1	929,501	128,703	541,666
1919	19,261	940,987	56.3	82.1	960,248	165,539	565,453

TABLE 22.—Wheat: Yield per acre, price per bushel Dec. 1, and value per acre, by States.

State.	Yield per acre (bushels).											Farm price per bushel (cents).					Value per acre (dollars). <sup>1</sup>		
	10-year average, 1910-1919.	1910	1911	1912	1913	1914	1915	1916	1917	1918	1919	10-year average, 1910-1919.	1915	1916	1917	1918	1919	5-year average, 1914-1918.	1919
Me.	23.7	29.7	21.0	23.5	25.5	27.0	28.0	27.0	14.0	22.0	19.0	152	112	187	235	237	220	39.26	41.80
Vt.	25.4	29.3	27.8	25.0	24.5	29.0	30.0	25.0	20.0	22.0	21.0	147	107	165	236	231	227	40.07	47.67
N. Y.	20.8	23.7	19.5	16.0	20.0	22.5	25.0	21.0	21.0	18.2	21.3	140	101	168	210	215	215	33.61	45.80
N. J.	18.4	18.5	17.4	18.5	17.6	18.0	20.0	20.0	19.0	17.0	28.0	142	106	164	213	215	220	30.13	39.60
Pa.	17.4	17.8	13.5	18.0	17.0	18.1	18.5	19.0	17.5	17.0	27.5	138	104	162	205	214	216	28.22	37.80
Del.	15.8	17.0	16.7	17.5	14.5	20.5	15.0	15.0	16.5	13.0	12.0	139	109	162	208	222	213	25.23	25.56
Md.	16.1	17.4	15.5	15.0	13.3	21.5	16.1	16.0	17.0	15.5	13.5	139	105	171	207	219	215	27.24	29.02
Va.	12.8	12.8	12.0	11.6	13.6	14.5	13.8	12.7	13.0	12.0	11.8	143	108	165	216	219	224	21.18	26.43
W. Va.	13.8	12.5	11.5	14.5	13.0	15.0	15.0	14.5	14.0	14.2	13.5	144	108	160	217	221	220	23.47	29.70
N. C.	10.2	11.4	10.6	8.9	11.7	12.0	10.9	10.5	10.0	7.0	8.5	154	120	176	234	230	233	17.02	19.80
S. C.	10.7	11.0	11.4	9.2	12.3	11.5	10.8	10.6	10.5	11.0	9.0	178	138	189	290	260	258	22.13	23.22
Ga.	10.8	10.5	12.0	9.3	12.2	12.1	11.0	11.4	8.5	10.2	10.5	175	129	186	290	266	263	20.68	27.62
Ohio	17.0	16.2	16.0	8.0	18.0	18.5	20.3	13.5	22.0	19.0	19.0	138	104	169	204	212	212	29.70	40.28
Ind.	15.9	15.6	14.7	8.0	18.5	17.4	17.2	12.0	18.5	21.0	15.9	135	102	169	203	208	210	27.40	33.39
Ill.	16.3	15.0	16.0	8.3	18.7	18.5	19.0	11.0	18.7	22.1	15.8	134	100	165	201	208	210	27.88	33.18
Mich.	17.1	18.0	18.0	10.0	15.3	19.7	21.3	16.6	18.0	14.2	19.6	136	101	167	204	209	210	27.18	41.16
Wis.	19.3	19.3	15.9	19.0	19.3	19.1	22.7	17.6	22.3	24.2	13.4	132	95	160	202	205	215	32.70	28.81
Minn.	14.1	16.0	10.1	15.5	16.2	10.6	17.0	7.6	17.5	20.9	9.4	134	90	162	202	204	250	23.28	23.50
Iowa	18.5	21.0	16.4	19.8	20.6	18.6	20.0	16.3	19.9	18.9	13.9	126	87	156	199	200	200	27.62	27.80
Mo.	14.3	13.8	15.7	12.5	17.1	17.0	12.3	8.5	15.3	17.2	13.5	132	98	165	195	205	209	21.57	28.22

<sup>1</sup> Based upon farm price Dec. 1.



WHEAT—Continued.

TABLE 24.—Winter wheat: Per cent of area sown which was abandoned (not harvested).

Year.	Per cent.	Year.	Per cent.	Year.	Per cent.
1902.....	15.2	1908.....	4.2	1914.....	3.1
1903.....	2.8	1909.....	7.5	1915.....	2.7
1904.....	15.4	1910.....	13.7	1916.....	11.4
1905.....	4.6	1911.....	10.7	1917.....	31.0
1906.....	5.5	1912.....	20.1	1918.....	13.7
1907.....	11.2	1913.....	4.7	1919.....	1.1

TABLE 25.—Wheat: Farm price, cents per bushel on first of each month, 1910–1919.

Date.	1919	1918	1917	1916	1915	1914	1913	1912	1911	1910	Average.
Jan. 1.....	204.8	201.9	150.3	102.8	107.8	81.0	76.2	88.0	88.6	103.4	120.5
Feb. 1.....	207.5	201.2	164.8	113.9	129.9	81.6	79.9	90.4	89.8	105.0	126.4
Mar. 1.....	208.0	202.7	164.4	102.9	133.6	83.1	80.6	90.7	85.4	105.1	125.6
Apr. 1.....	214.2	202.6	180.0	98.6	131.7	84.2	79.1	92.5	83.8	104.5	127.1
May 1.....	231.1	203.6	245.9	102.5	139.6	83.9	80.9	99.7	84.6	99.9	137.2
June 1.....	228.4	202.5	248.5	100.0	131.5	84.4	82.7	102.8	86.3	97.6	136.5
July 1.....	222.0	203.2	220.1	93.0	102.8	76.9	81.4	99.0	84.3	95.3	127.8
Aug. 1.....	217.2	204.5	228.9	107.1	106.5	76.5	77.1	89.7	82.7	98.9	128.9
Sept. 1.....	205.7	205.6	209.7	131.2	95.0	93.3	77.1	85.8	84.8	95.8	128.4
Oct. 1.....	209.6	205.8	200.6	136.3	90.9	93.5	77.9	83.4	88.4	93.7	128.0
Nov. 1.....	213.2	206.0	200.0	158.4	93.1	97.2	77.0	83.8	91.5	90.5	131.1
Dec. 1.....	215.1	204.2	200.8	160.3	91.9	98.6	79.9	76.0	87.4	88.3	130.2
Average.....	212.8	204.3	200.8	125.9	105.2	88.4	78.4	87.4	86.9	96.5	128.7

TABLE 26.—Wheat: Monthly marketings by farmers, 1914–1919.

Month.	Estimated amount sold monthly by farmers of United States (millions of bushels).					Per cent of year's sales.				
	1918–19	1917–18	1916–17	1915–16	1914–15	1918–19	1917–18	1916–17	1915–16	1914–15
July.....	136	41	83	60	141	17.6	7.4	13.3	7.1	17.5
August.....	154	69	111	94	106	19.9	12.4	17.9	11.0	13.2
September.....	139	108	104	122	125	18.0	19.3	16.8	14.4	15.5
October.....	107	101	87	123	100	13.8	18.0	14.1	14.5	12.5
November.....	67	77	60	105	83	8.7	13.7	9.7	12.4	10.3
December.....	56	43	35	94	60	7.3	7.6	5.6	11.0	7.5
January.....	36	26	45	58	41	4.6	4.7	7.2	6.8	5.1
February.....	24	22	20	58	46	3.1	3.9	3.3	6.8	5.7
March.....	16	21	24	32	26	2.0	3.7	3.9	3.8	3.3
April.....	13	23	19	33	37	1.6	4.1	3.1	3.9	4.6
May.....	15	17	19	40	22	1.9	3.1	3.0	4.7	2.7
June.....	12	12	13	31	17	1.5	2.1	2.1	3.6	2.1
Season.....	775	560	620	851	804	100.0	100.0	100.0	100.0	100.0

TABLE 27.—Durum wheat production: Receipts at primary markets, and exports, 1905–1918.

Year.	Production in 4 States. <sup>1</sup>	Receipts at 7 primary markets. <sup>2</sup>	Exports, year beginning July 1.	Year.	Production in 4 States. <sup>1</sup>	Receipts at 7 primary markets. <sup>2</sup>	Exports, year beginning July 1.
	<i>Bushels.</i>	<i>Bushels.</i>	<i>Bushels.</i>		<i>Bushels.</i>	<i>Bushels.</i>	<i>Bushels.</i>
1905.....			7,015,225	1912.....	<sup>3</sup> 34,561,000	22,539,000	15,461,129
1906.....			22,638,565	1913.....	<sup>3</sup> 21,529,000	20,625,000	11,785,000
1907.....		31,600,604	27,053,478	1914.....	<sup>3</sup> 18,103,000	21,356,600	15,229,401
1908.....		32,600,569	20,777,435	1915.....	40,365,000	43,867,120	24,780,169
1909.....	38,115,000	34,762,000	18,344,972	1916.....	<sup>3</sup> 10,887,000	22,503,511	17,385,073
1910.....	<sup>3</sup> 24,131,000	19,764,000	3,273,703	1917.....	25,945,000	16,087,974	6,587,795
1911.....	<sup>3</sup> 16,024,000	5,830,000	1,851,988	1918.....	49,414,000	33,311,793	18,329,257

<sup>1</sup> These 4 States are: Minnesota, North Dakota, South Dakota, Montana.

<sup>2</sup> These 7 markets are: Chicago, Duluth, Kansas City, Milwaukee, Minneapolis, Omaha, St. Louis.

<sup>3</sup> Does not include Montana.

TABLE 28.—Wheat: Wholesale price per bushel, 1913-1919.

Date.	New York.			Baltimore.			Chicago.			Detroit.			St. Louis.			Minneapolis.			San Francisco.		
	No. 2 red winter. <sup>1</sup>			No. 2 red.			No. 1 northern spring. <sup>2</sup>			No. 2 red.			No. 2 red winter.			No. 1 northern.			White (100 lbs.). <sup>3</sup>		
	Low.	High.	Average.	Low.	High.	Average.	Low.	High.	Average.	Low.	High.	Average.	Low.	High.	Average.	Low.	High.	Average.	Low.	High.	Average.
1913.	Cts.	Cts.	Cts.	Cts.	Cts.	Cts.	Cts.	Cts.	Cts.	Cts.	Cts.	Cts.	Cts.	Cts.	Cts.	Cts.	Cts.	Cts.	Cts.	Cts.	Cts.
January-June.....	107	114½	111.2	105¾	109½	107.0	87¼	96	91.9	102½	116¼	.....	93	115	106.3	82½	95	88.3	147½	182½	157.7
July-December.....	94	107	98.0	89¼	96½	92.4	85	95¼	90.8	87½	102½	.....	83	97¾	91.6	80¾	93½	86.7	145	172½	150.0
1914.																					
January-June.....	87½	111¾	101.4	83	103	98.1	89	100	95.2	86¼	99¼	.....	75¾	99½	94.0	84½	98¼	91.5	151¼	165	158.1
July-December.....	86¼	136½	114.0	82¾	127	106.6	88½	133	112.9	80	127¼	.....	76	127½	105.2	85½	129½	110.0	152	200	173.1
1915.																					
January-June.....	126	178	157.1	111	168½	148.0	123	167	150.7	114½	165	147.3	110	164	145.2	114¾	165½	146.5	165	240	213.1
July-December.....	108¼	144½	123.6	100¼	127½	112.5	99	153¾	117.6	106	132	114.5	106	129	118.0	89	155	115.1	140	185	162.1
1916.																					
January-June.....	113¼	156¼	136.6	100¼	141¼	118.8	106½	139½	122.1	103	137	119.8	106	143	123.6	106½	138¾	120.6	150	190	166.2
July-December.....	123½	215	179.5	102½	193¼	156.6	110	202	162.0	104	189½	156.3	109	196	162.2	107¾	200	164.0	160	290	219.5
1917.																					
January-June.....	197	320	241.1	168½	342	234.2	162½	340	230.3	171	340	233.7	171	342	238.1	166¾	339	229.0	250	500	329.5
July-December.....	229	231	229.4	209	240	223.7	217	300	234.3	215	255	223.0	210	273	221.2	215	305	231.8	330	390	351.8
1918.																					
January-June.....	228	229	228.2	222	227	226.0	220	220	220.0	217	219	217.5	215	215	215.0	215	217	216.5	350	350	350.0
July-December.....	229	240½	239.5	230	235¾	235.7	226	234	227.6	217	230	223.5	221	248½	224.2	221½	238	225.1	350	350	350.0
1919.																					
January.....	240½	240½	240.5	235¾	235¾	235.8	223	232	226.6	230	230	230.0	236	254	244.5	221½	225½	222.0	350	350	350.0
February.....	237½	240½	240.5	235¾	235¾	235.8	223	230	225.6	230	230	230.0	235	243	239.3	221½	231	223.0	350	350	350.0
March.....	240½	240½	240.5	233¾	235¾	235.8	224	257	238.8	230	245	235.3	236	265	253.2	221½	250	234.3	350	350	350.0
April.....	240½	240½	240.5	244	248	245.8	239	292	255.0	245	270	254.3	265	278	270.5	242	289	258.2	350	350	350.0
May.....	240½	240½	240.5	(4)	(4)	(4)	245	280	258.4	255	270	266.3	245	278	262.8	247	273	259.5	350	350	350.0
June.....	240½	240½	240.5	(4)	(4)	(4)	228	251	240.5	240	255	246.5	235	247	242.6	237	258	248.6	350	350	350.0
January-June.....	237½	240½	240½	233¾	248	238.1	223	292	240.8	230	270	243.7	235	278	252.2	221½	289	240.9	350	350	350.0
July.....	240½	240½	240.5	235¾	235¾	235.8	229	270	249.6	223	226½	228.0	221	242	224.2	250	300	269.9	(5)	(5)	(5)
August.....	240½	240½	240.5	235¾	235¾	235.8	220	258	238.9	226½	227	226.6	221	223	221.5	230	290	257.3	(5)	(5)	(5)
September.....	237½	240½	239.7	235¾	235¾	235.8	223	285	251.1	225	227	225.6	221	223½	221.3	230	275	252.6	(5)	(5)	(5)
October.....	237½	237½	237.5	235¾	235¾	235.8	242	288	268.4	225	227	226.7	221	229	224.6	235	270	259.9	(5)	(5)	(5)
November.....	237½	237½	237.5	235¾	235¾	235.8	230	322	297.8	227	235	227.4	224	241	230.3	265	315	284.2	(5)	(5)	(5)
December.....	236½	237½	236.7	235¾	235¾	235.8	280	325	307.5	234	255	244.6	240	257	250.0	295	320	302.4	(5)	(5)	(5)
July-December.....	236½	240½	238.7	235¾	235¾	235.8	220	325	268.9	223	255	229.8	221	257	228.7	230	320	271.0	(5)	(5)	(5)

<sup>1</sup> No. 1 northern spring, 1916-1918.

<sup>2</sup> No. 2 northern, 1919.

<sup>3</sup> Northern club in 1913.

<sup>4</sup> No quotations.

<sup>5</sup> Basic.

WHEAT—Continued.

TABLE 29.—Wheat flour: Wholesale price per barrel, 1913-1919.

Date.	Chicago.						Cincinnati.			New York.			St. Louis.		
	Winter patents.			Spring patents.			Winter patents.			Spring patents.			Winter patents.		
	Low	High	Average.	Low	High	Average.	Low	High	Average.	Low	High	Average.	Low	High	Average.
1913.	Dols.	Dols.	Dols.	Dols.	Dols.	Dols.	Dols.	Dols.	Dols.	Dols.	Dols.	Dols.	Dols.	Dols.	Dols.
January-June	4.30	5.10	.....	4.10	5.60	.....	3.25	4.15	.....	4.40	5.00	.....	4.30	5.15	.....
July-December	3.90	4.35	.....	4.00	5.50	.....	2.90	3.50	.....	4.40	5.00	.....	3.70	4.55	.....
1914.															
January-June	3.50	4.40	.....	4.00	5.50	.....	3.20	3.50	.....	4.50	5.10	.....	3.35	4.35	.....
July-December	3.45	5.50	.....	4.00	6.90	.....	3.05	4.90	.....	4.35	7.00	.....	3.35	5.70	.....
1915.															
January-June	5.10	7.80	.....	5.50	6.75	.....	4.75	6.65	.....	5.50	8.25	.....	5.10	7.50	.....
July-December	4.50	5.75	.....	4.50	6.90	.....	4.65	5.65	.....	4.90	7.25	.....	4.60	5.90	.....
1916.															
January-June	5.00	6.80	.....	5.00	6.85	.....	4.50	5.50	.....	5.45	7.25	.....	4.75	6.10	.....
July-December	5.10	8.65	.....	5.20	9.75	.....	4.50	8.75	.....	5.50	10.00	.....	4.75	9.00	.....
1917.															
January-June	8.10	17.00	.....	8.20	17.80	.....	7.25	15.25	.....	8.65	16.75	.....	7.90	15.25	.....
July-December	9.85	12.50	.....	10.20	14.00	.....	9.50	11.50	.....	10.45	13.75	.....	9.80	11.75	.....
1918.															
January-June	10.10	11.25	10.65	10.10	11.75	10.96	10.70	11.35	10.98	10.55	11.25	10.87	10.00	12.50	10.74
July-December	9.80	10.90	10.60	9.80	11.72	11.10	10.35	11.25	10.89	10.50	11.95	11.06	8.89	11.65	9.70
1919.															
January	10.00	10.80	10.53	10.40	11.00	10.70	10.85	11.25	10.99	10.35	10.90	10.76	10.60	12.00	11.33
February	10.50	10.80	10.70	10.40	11.00	10.66	10.70	10.85	10.83	10.50	11.00	10.85	10.50	11.85	11.29
March	10.50	10.80	10.67	10.40	12.00	11.28	10.50	11.60	11.02	10.60	12.00	11.37	9.80	11.75	10.39
April	10.50	12.90	11.54	11.00	15.00	12.54	11.75	12.00	11.88	11.45	13.25	12.15	11.00	12.65	11.52
May	12.25	12.70	12.41	12.00	15.00	13.06	11.75	12.50	12.18	11.75	13.00	12.51	10.70	12.00	11.38
June	11.40	12.25	11.85	11.50	13.50	12.25	11.85	13.25	12.25	11.50	12.50	11.93	9.50	11.75	10.23
January-June	10.00	12.90	11.28	10.40	15.00	11.75	10.50	13.25	11.52	10.35	13.25	11.60	9.50	12.65	11.02
July	9.80	11.75	10.86	11.65	13.50	12.43	11.00	12.50	11.85	11.50	12.75	13.46	9.70	10.55	9.92
August	9.30	13.00	10.41	11.25	13.50	12.76	10.75	12.50	11.38	11.35	12.75	12.35	9.80	10.50	10.12
September	10.00	11.00	10.48	10.75	13.20	11.67	10.75	11.25	11.00	11.25	12.25	11.72	9.40	10.25	9.93
October	10.00	12.75	11.51	10.00	13.60	11.53	10.75	11.25	11.10	11.85	12.75	12.20	9.60	10.25	9.56
November	10.25	11.25	10.81	11.50	13.80	12.71	11.00	11.25	11.12	12.00	14.25	13.08	9.65	10.80	10.19
December	10.40	12.75	11.71	11.75	14.00	12.50	11.00	12.00	11.50	13.75	15.00	14.35	10.20	12.00	11.31
July-December	9.30	13.00	10.96	10.00	14.00	12.27	10.75	12.50	11.32	11.25	15.00	12.86	9.40	12.00	10.17

## WHEAT—Continued.

TABLE 30.—Wheat and flour: International trade, calendar years 1909-1913, 1917, and 1918.

["Temporary" imports into Italy of wheat to be used for manufacturing products for export are included in the total imports as given in the official Italian returns. In the trade returns of Chile the item trigo mote (prepared corn), which might easily be confused with trigo (wheat), is omitted. See "General note," Table 12.]

## EXPORTS.

[000 omitted.]

Country.	Wheat.			Wheat flour.			Wheat and flour.		
	Average 1909-1913	1917 (prelim.)	1918 (prelim.)	Average 1909-1913	1917 (prelim.)	1918 (prelim.)	Average 1909-1913	1917 (prelim.)	1918 (prelim.)
<i>From—</i>	<i>Bushels.</i>	<i>Bushels.</i>	<i>Bushels.</i>	<i>Barrels.</i>	<i>Barrels.</i>	<i>Barrels.</i>	<i>Bushels.</i>	<i>Bushels.</i>	<i>Bushels.</i>
Argentina.....	89,102	34,385	110,098	1,365	1,265	1,985	95,243	40,078	119,029
Australia.....	41,997	22,982	.....	1,719	3,817	.....	49,732	40,159	.....
Austria-Hungary.....	36	.....	.....	193	.....	.....	906	.....	.....
Belgium.....	19,607	.....	.....	686	.....	.....	22,694	.....	.....
British India.....	48,781	53,872	22,332	607	878	403	51,510	57,822	24,144
Bulgaria.....	8,840	.....	.....	534	.....	.....	11,244	.....	.....
Canada.....	74,247	146,874	55,054	3,694	8,771	10,071	90,871	186,342	100,372
Chile.....	2,221	529	.....	83	131	.....	2,593	1,118	.....
Germany.....	12,214	.....	.....	1,986	.....	.....	21,149	.....	.....
Netherlands.....	53,397	.....	.....	222	.....	.....	54,394	.....	.....
Roumania.....	49,106	.....	.....	725	.....	.....	52,370	.....	.....
Russia.....	155,752	.....	.....	1,337	.....	.....	161,766	.....	.....
United States.....	53,316	106,196	111,177	10,443	13,926	21,707	100,310	168,864	208,857
Other countries.....	16,210	.....	.....	3,154	.....	.....	30,412	.....	.....
Total.....	624,827	.....	.....	26,748	.....	.....	745,194	.....	.....

## IMPORTS.

<i>Into—</i>									
Belgium.....	73,826	.....	.....	31	.....	.....	73,967	.....	.....
Brazil.....	12,283	6,685	10,935	1,825	1,237	1,681	20,495	12,251	18,499
British South Africa.....	3,425	2,586	1,257	729	291	126	6,708	3,898	1,824
Denmark.....	4,088	1,272	20	583	84	63	6,711	1,649	302
France.....	38,172	63,458	43,154	117	5,339	6,549	38,698	87,484	72,627
Germany.....	88,982	.....	.....	172	.....	.....	89,755	.....	.....
Greece.....	6,973	2,893	.....	13	60	.....	7,034	3,165	.....
Italy.....	52,775	70,400	56,655	15	1,522	4,892	52,806	77,249	78,671
Japan.....	2,629	283	2,563	192	4	69	3,495	301	2,874
Netherlands.....	66,896	.....	.....	2,168	.....	.....	76,653	.....	.....
Portugal.....	3,228	.....	.....	.....	.....	.....	3,228	.....	.....
Spain.....	4,468	1,858	4,619	1	1	10	4,471	1,861	4,664
Sweden.....	6,771	3,588	.....	82	19	.....	7,140	3,694	.....
Switzerland.....	16,558	9,617	2,119	517	.....	.....	18,885	9,617	2,119
United Kingdom.....	192,134	170,524	108,059	6,005	7,940	14,978	219,156	206,255	175,460
Other countries.....	21,790	.....	.....	11,070	.....	.....	71,574	.....	.....
Total.....	594,998	.....	.....	23,520	.....	.....	700,836	.....	.....

OATS.

TABLE 31.—Oats: Area and production in undermentioned countries, 1909–1919.  
[000 omitted.]

Country.	Area.				Production.			
	Average 1909–1913. <sup>1</sup>	1917	1918	1919	Average 1909–1913. <sup>1</sup>	1917	1918	1919
NORTH AMERICA.								
United States.....	<i>Acres.</i> 37,357	<i>Acres.</i> 43,553	<i>Acres.</i> 44,349	<i>Acres.</i> 42,400	<i>Bushels.</i> 1,131,175	<i>Bushels.</i> 1,592,740	<i>Bushels.</i> 1,538,124	<i>Bushels.</i> 1,248,310
Canada:								
New Brunswick.....	204	190	224	305	5,933	4,275	7,051	9,852
Quebec.....	1,451	1,493	1,933	2,141	40,294	32,466	52,667	61,022
Ontario.....	2,964	2,687	2,924	2,674	105,036	98,075	131,752	76,219
Manitoba.....	1,379	1,500	1,715	1,847	54,192	45,375	54,474	64,193
Saskatchewan.....	2,293	4,522	4,988	4,838	98,481	123,214	107,253	117,316
Alberta.....	1,223	2,538	2,652	2,767	52,045	86,289	60,323	65,725
Other.....	326	383	354	425	11,697	13,316	12,792	16,809
Total Canada.....	9,840	13,313	14,790	14,997	367,678	403,010	426,312	411,136
Mexico.....	( <sup>2</sup> )	( <sup>2</sup> )	( <sup>2</sup> )	( <sup>2</sup> )	17	( <sup>2</sup> )	( <sup>2</sup> )	( <sup>2</sup> )
Total.....	47,197	56,866	59,139	57,397	1,498,870	1,995,750	1,964,436	1,659,446
SOUTH AMERICA.								
Argentina.....	1,999	2,525	3,200	2,980	52,122	32,009	68,635	44,120
Chile.....	68	126	79	79	2,934	5,564	3,177	3,250
Uruguay.....	46	142	165	( <sup>2</sup> )	830	1,926	3,697	( <sup>2</sup> )
Total.....	2,113	2,793	3,444	.....	55,886	39,499	75,509	.....
EUROPE.								
Austria <sup>3</sup> .....	4,613	( <sup>2</sup> )	( <sup>2</sup> )	( <sup>2</sup> )	143,392	( <sup>2</sup> )	( <sup>2</sup> )	( <sup>2</sup> )
Hungary proper <sup>3</sup> .....	2,669	( <sup>2</sup> )	( <sup>2</sup> )	( <sup>2</sup> )	85,840	( <sup>2</sup> )	( <sup>2</sup> )	( <sup>2</sup> )
Croatia-Slavonia <sup>3</sup> .....	246	( <sup>2</sup> )	( <sup>2</sup> )	( <sup>2</sup> )	5,216	( <sup>2</sup> )	( <sup>2</sup> )	( <sup>2</sup> )
Bosnia-Herzegovina <sup>3</sup> .....	225	( <sup>2</sup> )	( <sup>2</sup> )	( <sup>2</sup> )	4,973	( <sup>2</sup> )	( <sup>2</sup> )	( <sup>2</sup> )
Belgium.....	644	( <sup>2</sup> )	( <sup>2</sup> )	550	40,905	( <sup>2</sup> )	( <sup>2</sup> )	26,920
Bulgaria <sup>3</sup> .....	455	( <sup>2</sup> )	( <sup>2</sup> )	( <sup>2</sup> )	9,880	<sup>4</sup> 10,012	( <sup>2</sup> )	( <sup>2</sup> )
Denmark.....	1,028	981	937	961	43,115	37,653	41,571	( <sup>2</sup> )
Finland.....	( <sup>2</sup> )	( <sup>2</sup> )	( <sup>2</sup> )	( <sup>2</sup> )	21,989	( <sup>2</sup> )	( <sup>2</sup> )	( <sup>2</sup> )
France <sup>3</sup> .....	9,801	7,308	6,721	6,815	310,020	214,259	176,504	168,303
Germany <sup>3</sup> .....	10,750	<sup>5</sup> 8,625	<sup>5</sup> 8,071	( <sup>2</sup> )	591,996	<sup>5</sup> 249,964	<sup>4</sup> 322,475	( <sup>2</sup> )
Greece.....	( <sup>2</sup> )	( <sup>2</sup> )	( <sup>2</sup> )	156	( <sup>2</sup> )	( <sup>2</sup> )	( <sup>2</sup> )	( <sup>2</sup> )
Italy.....	1,253	1,107	1,211	1,129	36,945	33,889	41,336	34,722
Luxemburg.....	( <sup>2</sup> )	56	48	( <sup>2</sup> )	( <sup>2</sup> )	2,015	1,459	( <sup>2</sup> )
Netherlands.....	346	371	392	368	18,512	18,594	18,617	20,512
Norway.....	266	356	343	343	10,245	17,004	16,582	16,810
Roumania.....	<sup>3</sup> 1,105	( <sup>2</sup> )	<sup>6</sup> 1,084	<sup>6</sup> 866	<sup>3</sup> 27,545	( <sup>2</sup> )	<sup>6</sup> 5,890	( <sup>2</sup> )
Russia proper <sup>3</sup> .....	38,013	( <sup>2</sup> )	( <sup>2</sup> )	( <sup>2</sup> )	874,945	( <sup>2</sup> )	( <sup>2</sup> )	( <sup>2</sup> )
Poland <sup>3</sup> .....	2,858	( <sup>2</sup> )	( <sup>2</sup> )	( <sup>2</sup> )	76,590	( <sup>2</sup> )	( <sup>2</sup> )	( <sup>2</sup> )
Northern Caucasia <sup>3</sup> .....	1,190	( <sup>2</sup> )	( <sup>2</sup> )	( <sup>2</sup> )	29,602	( <sup>2</sup> )	( <sup>2</sup> )	( <sup>2</sup> )
Serbia <sup>3</sup> .....	266	( <sup>2</sup> )	( <sup>2</sup> )	( <sup>2</sup> )	5,443	( <sup>2</sup> )	( <sup>2</sup> )	( <sup>2</sup> )
Spain.....	1,276	1,425	1,507	1,538	29,110	33,048	30,474	28,814
Sweden.....	1,969	1,933	1,811	( <sup>2</sup> )	79,115	<sup>4</sup> 67,142	57,880	( <sup>2</sup> )
United Kingdom:								
England.....	1,835	2,013	2,415	( <sup>2</sup> )	74,750	80,981	104,480	( <sup>2</sup> )
Wales.....	204	246	365	( <sup>2</sup> )	7,274	8,678	13,847	( <sup>2</sup> )
Scotland.....	952	1,041	1,244	1,110	37,670	44,949	53,284	40,340
Ireland.....	1,049	1,464	1,579	( <sup>2</sup> )	63,083	80,119	85,822	( <sup>2</sup> )
Total United Kingdom.....	4,040	4,764	5,603	.....	182,777	214,727	257,433	.....
Total.....	83,013	.....	.....	.....	2,628,155	.....	.....	.....
ASIA.								
Cyprus.....	( <sup>2</sup> )	( <sup>2</sup> )	( <sup>2</sup> )	( <sup>2</sup> )	429	<sup>4</sup> 447	( <sup>2</sup> )	( <sup>2</sup> )
Russia:								
Central Asia (4 governments) <sup>3</sup> .....	938	( <sup>2</sup> )	( <sup>2</sup> )	( <sup>2</sup> )	15,044	( <sup>2</sup> )	( <sup>2</sup> )	( <sup>2</sup> )
Siberia (4 governments) <sup>3</sup> .....	3,972	( <sup>2</sup> )	( <sup>2</sup> )	( <sup>2</sup> )	72,305	( <sup>2</sup> )	( <sup>2</sup> )	( <sup>2</sup> )
Transcaucasia (1 government) <sup>3</sup> .....	2	( <sup>2</sup> )	( <sup>2</sup> )	( <sup>2</sup> )	54	( <sup>2</sup> )	( <sup>2</sup> )	( <sup>2</sup> )
Total.....	4,912	.....	.....	.....	87,832	.....	.....	.....

<sup>1</sup> Five-year average except in a few cases where statistics for 5 years were not available.  
<sup>2</sup> No official statistics.  
<sup>3</sup> Old boundaries.  
<sup>4</sup> Unofficial estimate.  
<sup>5</sup> Excluding Alsace-Lorraine.  
<sup>6</sup> Including Bessarabia but excluding Dobrudja.

## OATS—Continued.

TABLE 31.—Oats: Area and production in undermentioned countries, 1909–1919—Con.  
[000 omitted.]

Country.	Area.				Production.			
	Average 1909– 1913.	1917	1918	1919	Average 1909– 1913.	1917	1918	1919
AFRICA.								
	<i>Acres.</i>	<i>Acres.</i>	<i>Acres.</i>	<i>Acres.</i>	<i>Bushels.</i>	<i>Bushels.</i>	<i>Bushels.</i>	<i>Bushels.</i>
Algeria.....	456	682	588	533	12,950	16,125	22,914	11,219
Tunis.....	141	124	151	127	4,333	3,996	4,271	3,445
Union of South Africa.....	(1)	250	257	(1)	7,197	6,927	(1)	(1)
Total.....	597	1,056	996	.....	24,480	27,048	.....	.....
AUSTRALASIA.								
Australia:								
Queensland.....	2	7	(1)	(1)	47	109	(1)	(1)
New South Wales.....	75	67	(1)	(1)	1,571	1,083	(1)	(1)
Victoria.....	388	442	(1)	(1)	8,592	8,289	(1)	(1)
South Australia.....	101	152	107	174	1,371	1,840	1,249	1,609
Western Australia.....	81	122	96	(1)	1,204	1,689	909	(1)
Tasmania.....	61	55	(1)	(1)	2,066	1,006	(1)	(1)
Total Australia.....	708	845	616	.....	14,851	14,016	10,387	.....
New Zealand.....	376	177	156	173	13,664	5,371	4,943	6,926
Total Australasia.....	1,084	1,022	772	.....	28,515	19,387	15,330	.....
Grand total.....	138,916	.....	.....	.....	4,323,738	.....	.....	.....

<sup>1</sup> No official statistics.

TABLE 32.—Oats: Total production in countries named in Table 31, 1895–1916.

Year.	Production.	Year.	Production.	Year.	Production.	Year.	Production.
	<i>Bushels.</i>		<i>Bushels.</i>		<i>Bushels.</i>		<i>Bushels.</i>
1895.....	3,008,154,000	1901.....	2,862,615,000	1907.....	3,603,896,000	1913.....	4,697,437,000
1896.....	2,847,115,000	1902.....	3,626,303,000	1908.....	3,591,012,000	1914.....	4,034,857,000
1897.....	2,633,971,000	1903.....	3,378,034,000	1909.....	4,312,882,000	1915.....	4,362,713,000
1898.....	2,903,974,000	1904.....	3,611,302,000	1910.....	4,182,410,000	1916.....	4,138,050,000
1899.....	3,256,256,000	1905.....	3,510,167,000	1911.....	3,808,561,000		
1900.....	3,166,002,000	1906.....	3,544,961,000	1912.....	4,617,394,000		

TABLE 33.—Oats: Average yield per acre in undermentioned countries, 1890–1919.

Year.	United States.	Russia (European). <sup>1</sup>	Germany. <sup>1</sup>	Austria. <sup>1</sup>	Hungary proper. <sup>1</sup>	France. <sup>2</sup>	United Kingdom. <sup>2</sup>
Average:	<i>Bushels.</i>	<i>Bushels.</i>	<i>Bushels.</i>	<i>Bushels.</i>	<i>Bushels.</i>	<i>Bushels.</i>	<i>Bushels.</i>
1890–1899.....	26.1	17.8	40.0	25.3	.....	29.8	43.6
1900–1909.....	29.3	20.0	50.7	29.8	30.7	31.6	44.3
1910–1914.....	30.5	21.8	54.7	37.5	31.9	31.0	42.9
1906.....	31.2	15.1	55.7	34.1	34.2	27.0	43.8
1907.....	23.7	19.7	58.3	35.7	30.0	31.8	45.1
1908.....	25.0	20.1	50.2	32.0	26.8	29.6	43.5
1909.....	28.6	25.7	59.0	37.4	33.8	34.1	45.9
1910.....	31.6	22.5	51.3	31.5	26.8	29.8	44.3
1911.....	24.4	18.6	49.6	33.7	33.8	30.8	41.5
1912.....	37.4	23.6	54.1	36.2	31.1	31.9	41.7
1913.....	29.2	26.3	61.1	39.3	34.6	31.6	43.0
1914.....	29.7	17.9	57.4	46.6	33.2	31.0	44.0
1915.....	37.8	22.4	36.2	21.6	30.4	25.6	44.3
1916.....	30.1	.....	<sup>3</sup> 54.4	.....	.....	30.2	42.5
1917.....	36.6	.....	<sup>3</sup> 29.0	.....	.....	<sup>1</sup> 36.8	45.1
1918.....	34.6	.....	<sup>3</sup> 39.9	.....	.....	28.4	46.0
1919.....	28.9	.....	.....	.....	.....	.....	.....

<sup>1</sup> Bushels of 32 pounds.<sup>2</sup> Winchester bushels.<sup>3</sup> Excluding Alsace-Lorraine.



OATS—Continued.

TABLE 34.—Oats: Acreage, production, value, exports, etc., in the United States, 1849–1919.

NOTE.—Figures in *italics* are census returns; figures in roman are estimates of the Department of Agriculture. Estimates of acres are obtained by applying estimated percentages of increase or decrease to the published numbers of the preceding year, except that a revised base is used for applying percentage estimates whenever new census data are available.

Year.	Acreage.		Production. <i>Bushels.</i>	Average farm price per bushel Dec. 1. <i>Cts.</i>	Farm value, Dec. 1. <i>Dollars.</i>	Chicago cash price per bushel, contract. <sup>1</sup>				Domestic exports, including oatmeal, fiscal year beginning July 1. <sup>2</sup> <i>Bushels.</i>	Imports, during fiscal year beginning July 1. <sup>3</sup> <i>Bushels.</i>
	<i>Acres.</i>	<i>Bush.</i>				December.		Following May.			
						<i>Cts.</i>	<i>Cts.</i>	<i>Cts.</i>	<i>Cts.</i>		
1849			146,584,000								
1859			172,643,000								
1866	8,864,000	30.2	268,141,000	35.1	94,058,000	36	43	59	78	825,895	778,198
1867	10,082,000	27.6	278,698,000	44.5	123,903,000	52	57½			122,554	780,798
1868	9,666,000	26.4	254,961,000	41.7	106,356,000	43	49½	56¾	62½	481,871	326,659
1869	9,461,000	30.5	288,334,000	38.0	109,522,000	40	44½	46½	53½	121,517	2,266,785
1869			282,107,000								
1870	8,792,000	28.1	247,277,000	39.0	96,444,000	37¾	41	47½	51	147,572	599,514
1871	8,366,000	30.6	255,743,000	36.2	92,591,000	30¾	33	34¾	42½	262,975	535,250
1872	9,001,000	30.2	271,747,000	29.9	81,304,000	23½	25¼	30	34	714,072	225,555
1873	9,752,000	27.7	270,340,000	34.6	93,474,000	34	40¾	44	48½	812,873	191,802
1874	10,897,000	22.1	240,369,000	47.1	113,134,000	51¾	54½	57½	64½	504,770	1,500,040
1875	11,915,000	29.7	354,318,000	32.0	113,441,000	29½	30½	28½	31½	1,466,228	121,547
1876	13,359,000	24.0	320,884,000	32.4	103,845,000	31¾	34½	37¼	45¾	2,854,128	41,597
1877	12,826,000	31.7	406,394,000	28.4	115,546,000	24½	27	23	27	3,715,479	21,391
1878	13,176,000	31.4	413,579,000	24.6	101,752,000	19¾	20¾	24¾	30½	5,452,136	13,395
1879	12,684,000	28.7	363,761,000	33.1	120,533,000	32¾	36½	29½	34¾	766,366	489,576
1879	16,145,000	25.3	407,859,000								
1880	16,188,000	25.8	417,885,000	36.0	150,244,000	29½	33½	36½	39½	402,904	64,412
1881	16,832,000	24.7	416,481,000	46.4	193,199,000	43½	46¾	48¾	56¾	625,690	1,850,983
1882	18,495,000	26.4	488,251,000	37.5	182,978,000	34¾	41½	38¾	42¾	461,496	815,017
1883	20,325,000	28.1	571,302,000	32.7	187,040,000	29¾	36½	30¾	34¼	3,274,622	121,069
1884	21,301,000	27.4	583,628,000	27.7	161,528,000	22½	25½	34½	37	6,203,104	94,310
1885	22,784,000	27.6	629,409,000	28.5	179,632,000	27	29	26½	29½	7,311,306	149,480
1886	23,658,000	26.4	624,134,000	29.8	186,138,000	25¾	27¼	25½	27½	1,374,635	139,575
1887	25,921,000	25.4	659,618,000	30.4	200,700,000	28¾	30¾	32½	38	573,080	123,817
1888	26,998,000	26.0	701,735,000	27.8	195,424,000	25	26¾	21¾	23¾	1,191,471	131,501
1889	27,462,000	27.4	751,515,000	22.9	171,781,000	20	21	24¾	30	15,107,238	153,232
1889	28,321,000	28.6	809,251,000								
1890	26,431,000	19.8	523,621,000	42.4	222,048,000	39¾	43¾	45½	54	1,382,836	41,848
1891	25,582,000	28.9	738,394,000	31.5	232,312,000	31½	33¾	28¾	33½	10,586,644	47,782
1892	27,064,000	24.4	661,035,000	31.7	209,254,000	25¾	31½	28¾	32½	2,700,793	49,433
1893	27,273,000	23.4	638,855,000	29.4	187,576,000	27½	29¾	32½	36	6,290,229	31,759
1894	27,024,000	24.5	662,037,000	32.4	214,817,000	28¾	29¾	27½	30½	1,708,824	330,318
1895	27,878,000	29.6	824,444,000	19.9	163,655,000	16¾	17½	18	19¾	15,156,618	66,602
1896	27,566,000	25.7	707,346,000	18.7	132,485,000	16½	18¾	16¾	18¼	37,725,083	131,204
1897	25,730,000	27.2	698,768,000	21.2	147,975,000	21	23¾	26	32	73,880,307	25,093
1898	25,777,000	28.4	730,907,000	25.5	186,405,000	26	27¾	24	27¾	33,534,362	28,098
1899	26,341,000	30.2	796,178,000	24.9	198,168,000	24½	23	21¼	23¾	45,048,857	54,576
1899	29,540,000	31.9	943,389,000								
1900	27,365,000	29.6	809,126,000	25.8	208,669,000	21¾	22¾	27¾	31	42,268,931	32,107
1901	28,541,000	25.8	736,809,000	39.9	293,659,000	42	48½	41	49½	13,277,612	38,978
1902	28,653,000	34.5	987,843,000	30.7	303,585,000	29¼	32	33¾	38½	8,381,805	150,065
1903	27,638,000	28.4	784,094,000	34.1	267,662,000	34¼	38	39¾	44¼	1,960,740	183,983
1904	27,843,000	32.1	894,596,000	31.3	279,900,000	28¼	32	28¾	32	8,394,692	55,699
1905	28,047,000	34.0	953,216,000	29.1	277,048,000	29½	32¼	32½	34¼	48,434,541	40,025
1906	30,959,000	31.2	964,905,000	31.7	306,293,000	33	35¾	44½	48½	6,386,334	91,289
1907	31,837,000	23.7	754,443,000	44.3	334,568,000	46½	50¾	52¾	56½	2,518,855	383,418
1908	32,344,000	25.0	807,156,000	47.2	381,171,000	48¾	50½	56½	62½	2,333,817	6,691,700
1909	33,204,000	30.3	1,007,353,000								
1909	35,159,000	28.6	1,007,145,000	40.2	405,121,000	40	45	36½	43¼	2,548,726	1,034,511
1910	37,548,000	31.6	1,186,341,000	34.4	408,388,000	31	32½	31¾	36	3,845,850	107,318
1911	37,763,000	24.4	922,298,000	45.0	414,663,000	46½	47¾	50½	58	2,677,749	2,622,357
1912	37,917,000	37.4	1,418,337,000	31.9	452,469,000	31	31¾	35¾	43	36,455,474	723,899
1913	38,399,000	29.2	1,121,768,000	39.2	439,596,000	37¾	40¾	37	42½	2,748,743	22,273,624
1914	38,442,000	29.7	1,141,060,000	43.8	499,431,000	46¾	49¼	50½	56	100,609,272	630,722
1915	40,996,000	37.8	1,549,030,000	36.1	559,506,000	40¾	44	39½	49½	98,960,481	665,314
1916	41,527,000	30.1	1,251,837,000	52.4	655,928,000	46½	54	59½	74	95,105,698	761,644
1917	43,553,000	36.6	1,592,740,000	66.6	1,061,474,000	70½	80¾	72	79½	125,090,611	2,591,077
1918	44,349,000	34.7	1,538,124,000	70.9	1,090,322,000	68	74½	67¾	74½	109,004,734	551,355
1919	42,400,000	29.4	1,248,310,000	71.7	895,603,000	77	89				

<sup>1</sup> Quotations are for No. 2 to 1906.

<sup>2</sup> Oatmeal not included 1867 to 1882, inclusive, and 1903.

<sup>3</sup> Oatmeal not included 1866 to 1882 inclusive. <sup>4</sup> Figures adjusted to census basis.

## OATS—Continued.

TABLE 35.—Oats: Revised acreage, production, and farm value, 1879 and 1889–1909.  
[See head note of Table 4.]

Year.	Acreage.	Average yield per acre.	Production.	Average farm price per bushel Dec. 1.	Farm value Dec. 1.
	<i>Acres.</i>	<i>Bushels.</i>	<i>Bushels.</i>	<i>Cents.</i>	<i>Dollars.</i>
1879.....	16,145,000	27.9	450,745,000	33.3	150,178,000
1880.....	28,321,000	28.3	801,586,000	21.9	175,801,000
1890.....	28,102,000	20.4	572,665,000	41.6	238,345,000
1891.....	27,604,000	30.4	838,876,000	30.6	256,814,000
1892.....	28,023,000	24.8	695,267,000	31.5	218,954,000
1893.....	28,452,000	23.8	676,154,000	29.1	196,505,000
1894.....	28,362,000	25.2	715,559,000	32.1	229,538,000
1895.....	29,379,000	30.2	885,900,000	19.4	172,186,000
1896.....	29,645,000	26.3	780,563,000	18.3	143,192,000
1897.....	28,353,000	27.9	791,591,000	20.8	164,886,000
1898.....	28,769,000	29.3	842,747,000	25.2	212,482,000
1899.....	29,540,000	31.3	925,555,000	24.5	226,588,000
1900.....	30,290,000	29.9	904,566,000	25.4	230,160,000
1901.....	29,894,000	26.0	778,531,000	40.0	311,374,000
1902.....	30,578,000	34.5	1,055,441,000	30.6	322,944,000
1903.....	30,866,000	27.5	848,824,000	33.8	286,879,000
1904.....	31,353,000	32.1	1,007,183,000	31.0	312,467,000
1905.....	32,072,000	33.3	1,068,780,000	28.8	308,086,000
1906.....	33,353,000	31.0	1,034,623,000	31.8	329,142,000
1907.....	33,641,000	24.0	807,308,000	44.3	357,340,000
1908.....	34,006,000	24.9	847,109,000	47.3	400,363,000
1909.....	35,159,000	30.4	1,068,289,000	40.6	433,869,000

TABLE 36.—Oats: Acreage, production, and total farm value, by States, 1918 and 1919.

State.	Thousands of acres.		Production (thousands of bushels).		Total value, basis Dec. 1 price (thousands of dollars).	
	1919	1918	1919	1918	1919	1918
Maine.....	169	169	5,746	6,760	\$5,286	\$6,084
New Hampshire.....	33	30	1,221	1,140	1,038	992
Vermont.....	110	110	3,960	4,510	3,564	4,059
Massachusetts.....	15	12	570	480	513	437
Rhode Island.....	2	2	68	84	65	76
Connecticut.....	20	19	620	722	546	650
New York.....	1,160	1,260	29,580	51,660	24,551	43,394
New Jersey.....	82	79	2,460	3,160	1,968	2,496
Pennsylvania.....	1,189	1,210	36,859	47,190	29,487	37,752
Delaware.....	5	5	115	175	104	152
Maryland.....	65	60	1,820	1,980	1,492	1,703
Virginia.....	240	225	5,280	5,175	5,280	5,175
West Virginia.....	190	160	4,750	4,320	4,322	3,931
North Carolina.....	322	300	3,767	5,100	3,993	5,508
South Carolina.....	510	500	11,730	11,000	12,903	12,980
Georgia.....	540	550	10,800	11,000	12,420	13,090
Florida.....	60	60	1,140	1,080	1,368	1,242
Ohio.....	1,548	1,700	51,858	74,800	37,338	52,360
Indiana.....	1,825	2,025	60,225	85,050	41,555	56,984
Illinois.....	4,102	4,508	123,060	198,352	86,142	132,896
Michigan.....	1,475	1,658	36,875	66,320	26,181	45,761
Wisconsin.....	2,339	2,378	78,123	110,815	54,686	74,246
Minnesota.....	3,220	3,282	90,160	134,562	57,702	84,774
Iowa.....	5,670	5,823	196,182	244,566	125,556	156,522
Missouri.....	1,417	1,524	38,259	44,196	27,164	30,937
North Dakota.....	2,400	2,575	38,400	60,512	25,728	36,912
South Dakota.....	1,850	2,050	53,650	79,950	33,800	47,170
Nebraska.....	2,133	2,531	69,962	56,188	45,475	36,522
Kansas.....	1,574	2,329	44,229	51,238	32,287	37,404
Kentucky.....	440	400	9,900	9,600	9,009	8,640

OATS—Continued.

TABLE 36.—Oats: Acreage, production, and total farm value, by States, 1918 and 1919—Continued.

States.	Thousands of acres.		Production (thousands of bushels).		Total value, basis Dec 1 price (thousands of dollars).	
	1919	1918	1919	1918	1919	1918
Tennessee.....	400	325	9,200	8,125	8,556	7,556
Alabama.....	372	428	6,696	8,132	7,031	8,701
Mississippi.....	278	322	5,282	6,440	5,546	6,891
Louisiana.....	75	80	1,650	2,000	1,650	1,980
Texas.....	2,250	1,510	94,500	22,197	60,480	20,421
Oklahoma.....	1,500	1,300	49,500	31,200	34,650	26,208
Arkansas.....	420	390	9,240	9,945	8,131	8,752
Montana.....	612	680	6,120	20,400	5,569	16,320
Wyoming.....	315	285	5,670	11,685	6,350	9,348
Colorado.....	249	251	6,524	7,530	5,872	6,024
New Mexico.....	65	46	2,340	1,288	2,223	1,146
Arizona.....	13	11	533	440	533	528
Utah.....	72	90	2,448	4,050	2,399	3,928
Nevada.....	12	14	384	532	384	628
Idaho.....	220	237	7,700	9,480	7,546	8,911
Washington.....	320	310	12,800	8,370	11,904	8,203
Oregon.....	347	361	11,104	9,025	10,216	8,664
California.....	175	175	5,250	5,600	5,040	5,264
United States.....	42,400	44,349	1,248,310	1,538,124	895,603	1,090,322

TABLE 37.—Oats: Production and distribution in the United States, 1897-1919.

[000 omitted, except in weight and quality columns.]

Year.	Old stock on farms Aug. 1.	Crop.			Total supplies.	Stock on farms Mar. 1 following.	Shipped out of county where grown.
		Quantity.	Weight per bushel.	Quality.			
	<i>Bushels.</i>	<i>Bushels.</i>	<i>Pounds.</i>	<i>P. ct.</i>	<i>Bushels.</i>	<i>Bushels.</i>	<i>Bushels.</i>
1897.....	71,139	698,768	28.6	87.6	769,907	271,729	204,147
1898.....	44,554	730,907	30.5	84.5	775,461	283,209	193,527
1899.....	50,537	796,178	29.7	89.5	846,715	290,937	223,014
1900.....	54,214	809,126	31.3	89.2	863,340	292,803	242,850
1901.....	47,713	736,809	31.1	83.7	784,522	226,393	143,398
1902.....	30,570	987,843	30.7	86.7	1,018,413	364,926	258,438
1903.....	73,352	784,094	31.0	79.9	857,446	273,708	223,959
1904.....	42,194	894,596	29.7	91.4	936,790	347,166	261,989
1905.....	55,836	953,216	31.5	92.4	1,009,052	379,805	277,133
1906.....	67,688	964,905	32.0	88.2	1,032,593	384,461	266,182
1907.....	68,258	754,443	29.4	77.0	822,701	267,476	210,923
1908.....	37,797	807,156	29.8	81.3	844,953	278,847	244,444
1909.....	26,323	1,007,143	32.7	91.4	1,033,466	365,438	329,255
1910.....	64,200	1,186,341	32.7	93.8	1,250,541	442,665	363,103
1911.....	67,801	922,298	31.1	84.6	990,099	289,989	265,944
1912.....	34,875	1,418,337	33.0	91.0	1,453,212	604,249	438,130
1913.....	103,916	1,121,768	32.1	89.1	1,225,684	419,481	297,365
1914.....	62,467	1,141,060	31.5	86.5	1,203,527	379,369	335,539
1915.....	55,607	1,549,030	33.0	87.5	1,604,637	598,148	465,823
1916.....	113,728	1,251,837	31.2	88.2	1,365,565	394,211	355,092
1917.....	47,834	1,592,740	33.4	95.1	1,640,574	599,208	514,117
1918.....	81,424	1,538,124	33.2	93.6	1,619,548	590,251	421,568
1919.....	93,045	1,248,310	31.1	84.7	1,341,355	422,814	321,223

## OATS—Continued.

TABLE 38.—Oats: Yield per acre, price per bushel Dec. 1, and value per acre, by States.

State.	Yield per acre (bushels).											Farm price per bushel (cents).					Value per acre (dollars).		
	10-year average, 1910-1919.	1910	1911	1912	1913	1914	1915	1916	1917	1918	1919	10-year average, 1910-1919.	1915	1916	1917	1918	1919	5-year average, 1914-1918.	1919
Me.	37.6	42.4	38.5	34.6	40.0	41.0	40.0	36.0	29.0	40.0	34.0	64	45	67	85	90	92	25.23	31.28
N. H.	37.7	42.8	33.8	39.0	35.0	38.0	38.0	37.0	38.0	38.0	37.0	65	54	69	84	87	85	26.61	31.45
Vt.	38.9	41.5	35.0	43.0	39.0	42.5	43.0	32.0	36.0	41.0	36.0	65	53	65	85	90	90	26.89	32.40
Mass.	36.0	35.5	35.0	34.0	35.0	37.0	36.0	32.0	37.0	40.0	38.0	64	51	66	81	91	90	25.31	34.20
R. I.	31.3	35.0	29.0	28.6	26.0	27.5	33.0	27.0	31.0	42.0	34.0	64	50	68	75	90	95	22.37	32.30
Conn.	32.4	36.8	35.1	30.7	28.0	29.0	32.5	30.0	33.0	38.0	31.0	64	55	69	79	90	88	22.96	27.28
N. Y.	32.8	34.5	29.5	30.8	33.5	31.5	40.5	26.0	35.0	41.0	25.5	58	45	62	75	84	83	22.22	21.16
N. J.	31.8	37.1	28.5	27.6	29.0	29.0	32.5	30.0	34.0	40.0	30.0	58	48	61	70	79	80	20.99	24.00
Pa.	33.2	35.2	28.3	33.1	31.0	30.0	38.0	31.0	35.0	39.0	31.0	56	44	57	73	80	80	21.29	24.80
Del.	30.5	33.8	30.0	30.5	30.5	27.0	33.5	30.0	32.0	35.0	23.0	60	51	62	78	87	90	20.92	20.70
Md.	29.8	30.0	27.0	30.0	28.0	27.0	34.0	29.5	31.0	33.0	28.0	59	49	61	75	86	82	20.07	22.96
Va.	21.9	22.0	20.0	22.2	21.5	15.5	25.0	23.5	24.5	23.0	22.0	67	55	63	84	100	100	16.22	22.00
W. Va.	25.0	25.2	22.0	28.0	24.0	20.0	29.0	23.0	27.0	27.0	25.0	64	51	64	79	91	91	17.28	22.75
N. C.	17.6	18.2	16.5	18.6	19.5	17.5	23.0	17.5	16.0	17.0	11.7	75	62	74	93	108	106	14.37	12.40
S. C.	20.3	21.0	20.4	21.5	23.5	20.0	19.0	18.0	15.0	22.0	23.0	82	67	80	100	118	110	16.46	25.30
Ga.	19.8	18.2	21.5	20.8	22.0	20.0	19.5	19.5	16.0	20.0	20.0	83	66	79	117	119	115	16.96	23.00
Fla.	16.9	16.2	13.5	17.2	18.0	18.0	20.0	15.0	14.0	18.0	19.0	82	70	71	98	115	120	14.33	22.80
Ohio	36.4	37.2	32.1	44.0	30.2	30.5	41.0	28.0	44.0	44.0	33.5	49	36	53	64	70	72	20.46	24.12
Ind.	34.1	35.4	28.7	40.1	21.4	28.5	40.0	30.0	42.0	42.0	33.0	47	34	51	63	67	69	19.15	22.77
Ill.	37.3	38.0	28.8	43.3	23.8	29.3	45.0	38.5	52.0	44.0	30.0	47	35	51	65	67	70	22.31	21.00
Mich.	33.4	34.0	28.6	34.9	30.0	33.5	42.0	30.0	36.0	40.0	25.0	49	35	53	64	69	71	19.26	17.75
Wis.	36.8	29.8	29.8	37.3	36.5	27.0	46.5	37.0	44.0	46.6	33.4	48	36	51	66	67	70	21.50	23.38
Minn.	33.4	28.7	22.8	41.7	37.8	28.0	43.0	26.5	37.0	41.0	28.0	44	32	47	53	63	64	17.31	17.92
Iowa	37.6	37.8	25.5	44.2	34.5	33.0	40.0	37.0	47.0	42.0	34.6	44	32	48	63	64	64	20.12	22.14
Mo.	27.1	33.6	14.8	33.0	21.2	21.5	26.0	25.0	40.0	29.0	27.0	49	38	53	61	70	71	15.46	19.17
N. Dak.	24.2	7.0	23.5	41.4	25.7	28.0	40.0	21.5	15.0	23.5	16.0	43	27	44	62	61	67	10.85	10.72
S. Dak.	29.3	23.0	7.4	33.8	26.5	27.5	42.0	30.5	34.0	39.0	29.0	43	28	46	61	59	63	16.00	18.27
Nebr.	28.5	28.0	13.9	24.4	26.5	32.0	32.0	35.5	38.0	22.2	32.8	45	31	47	61	65	65	15.40	21.32
Kans.	26.4	33.3	15.0	32.0	19.5	33.5	26.5	23.5	31.0	22.0	28.1	50	37	55	64	73	73	14.54	20.51
Ky.	23.1	25.0	18.4	26.9	19.8	21.0	26.0	21.0	26.0	24.0	22.5	61	48	60	76	90	91	15.51	20.48
Tenn.	22.7	23.0	19.5	21.7	21.0	23.0	24.5	21.0	25.0	25.0	23.0	63	50	62	83	93	93	16.29	21.39
Ala.	19.2	18.5	19.2	20.0	20.5	22.0	19.0	17.5	18.0	19.0	18.0	78	63	75	102	107	105	15.79	18.90
Miss.	19.6	19.2	18.4	17.4	20.0	23.0	21.5	18.0	19.0	20.0	19.0	75	60	74	94	107	105	16.09	19.95
La.	22.2	21.5	21.0	20.8	22.0	23.0	25.0	19.0	22.3	25.0	22.0	70	55	68	94	99	100	17.37	22.00
Tex.	30.0	35.0	25.1	36.0	32.5	25.0	35.5	28.5	26.0	14.7	42.0	58	42	61	82	92	64	15.83	26.88
Okla.	23.6	36.5	9.0	25.1	18.0	27.5	27.0	12.5	23.0	24.0	33.0	53	35	57	75	84	70	13.05	23.10
Ark.	24.1	27.5	20.0	19.9	26.5	24.0	27.0	21.0	28.0	25.5	22.0	63	52	68	75	88	88	16.90	19.36
Mont.	36.4	38.0	49.8	48.0	43.5	35.0	52.0	38.0	20.0	30.0	10.0	52	32	47	81	80	91	17.67	9.10
Wyo.	35.3	32.0	34.5	41.8	38.0	35.0	42.0	35.0	36.0	41.0	18.0	60	43	60	80	80	112	23.49	20.16
Colo.	35.8	39.1	35.0	42.8	35.0	40.0	39.0	33.0	38.0	30.0	26.2	57	41	60	76	80	90	21.33	23.58
N. Mex.	32.8	27.4	38.8	34.7	30.0	38.0	36.0	29.0	30.0	28.0	36.0	65	50	67	84	89	95	20.93	34.20
Ariz.	40.7	40.1	42.0	44.7	43.0	42.0	37.0	37.5	40.0	40.0	41.0	80	64	80	96	120	100	33.90	41.00
Utah	44.4	43.0	44.7	46.4	46.0	50.0	47.0	43.5	44.0	45.0	34.0	61	45	61	85	97	98	30.05	33.32
Nev.	42.3	44.7	45.0	40.0	43.0	52.0	45.0	43.0	40.0	38.0	32.0	74	55	75	96	118	100	33.77	32.00
Idaho	42.5	38.5	44.0	48.9	46.5	44.0	47.0	43.0	38.0	40.0	35.0	54	34	54	77	94	98	24.56	34.30
Wash.	44.5	42.8	51.7	48.2	47.5	47.0	50.0	52.0	38.5	27.0	40.0	58	37	51	81	98	93	24.48	37.20
Oreg.	35.9	34.5	34.7	38.2	42.3	35.0	44.0	48.0	25.0	25.0	32.0	56	37	49	75	96	92	19.66	29.44
Calif.	33.9	37.0	34.0	39.0	31.6	35.0	33.0	32.5	35.0	32.0	30.0	67	50	72	85	94	96	23.66	28.80
U. S.	32.1	31.6	24.4	37.4	29.2	29.7	37.8	30.1	36.6	34.7	29.4	49.2	36.1	52.4	66.6	70.9	71.7	18.28	21.12

<sup>1</sup> Based upon farm price Dec. 1.

OATS—Continued.

TABLE 39.—Oats: Farm price, cents per bushel on first of each month, 1910–1919.

Date.	1919	1918	1917	1916	1915	1914	1913	1912	1911	1910	Average.
Jan. 1.....	70.8	73.9	51.4	39.1	45.0	39.1	32.2	45.1	33.2	42.8	47.3
Feb. 1.....	64.3	78.7	55.2	44.6	50.1	39.3	32.4	47.5	33.1	45.0	49.0
Mar. 1.....	62.6	86.2	56.9	42.7	52.1	38.9	33.1	49.8	32.8	46.0	50.1
Apr. 1.....	65.8	88.9	61.5	42.0	53.4	39.5	33.1	52.0	32.3	45.6	51.4
May 1.....	70.9	86.0	71.0	42.6	53.4	39.5	34.2	56.0	33.2	43.3	53.0
June 1.....	71.2	78.1	69.9	42.1	51.3	40.0	36.0	55.3	34.7	43.0	52.2
July 1.....	70.9	76.3	68.9	40.4	46.7	38.8	37.7	52.5	37.5	42.1	51.2
Aug. 1.....	75.3	73.0	73.7	40.1	45.4	36.7	37.6	44.3	40.2	41.7	50.8
Sept. 1.....	71.7	70.3	61.7	43.1	38.5	42.3	39.3	35.0	40.4	38.4	48.1
Oct. 1.....	68.4	71.0	62.3	44.5	34.5	43.3	39.6	33.6	42.5	36.2	47.0
Nov. 1.....	68.7	68.2	61.7	49.0	34.9	42.9	37.9	33.6	43.8	34.9	47.6
Dec. 1.....	71.7	70.9	66.6	52.4	36.1	43.8	39.2	31.9	45.0	34.4	49.2
Average.....	69.5	74.6	62.7	44.0	42.5	40.9	36.8	41.4	38.7	39.9	49.1

TABLE 40.—Oats: Condition of crop, United States, on first of months named, 1899–1919.

Year.	Year.				Year.				Year.					
	June.	July.	August.	When harvested.	June.	July.	August.	When harvested.	June.	July.	August.	When harvested.		
1899.....	88.7	90.0	90.8	87.2	1906.....	85.9	84.0	82.8	81.9	1913.....	87.0	76.3	73.8	74.0
1900.....	91.7	85.5	85.0	82.9	1907.....	81.6	81.0	75.6	65.5	1914.....	89.5	84.7	79.4	75.8
1901.....	85.3	83.7	73.6	72.1	1908.....	92.9	85.7	76.8	69.7	1915.....	92.2	93.9	91.6	91.1
1902.....	90.6	92.1	89.4	87.2	1909.....	88.7	88.3	85.5	83.8	1916.....	86.9	86.3	81.5	78.0
1903.....	85.5	84.3	79.5	75.7	1910.....	91.0	82.2	81.5	83.3	1917.....	88.8	89.4	87.2	90.4
1904.....	89.2	89.8	86.6	85.6	1911.....	85.7	68.8	65.7	64.5	1918.....	93.2	85.5	82.8	84.4
1905.....	92.9	92.1	90.8	90.3	1912.....	91.1	89.2	90.3	92.3	1919.....	93.2	87.0	76.5	73.1

TABLE 41.—Oats: Monthly marketings by farmers, 1914–1919.

Month.	Estimated amount sold monthly by farmers of United States (millions of bushels).					Per cent of year's sales.				
	1918-19	1917-18	1916-17	1915-16	1914-15	1918-19	1917-18	1916-17	1915-16	1914-15
July.....	34	24	31	23	35	8.0	4.7	8.3	5.1	10.4
August.....	82	82	87	53	64	19.6	16.4	23.3	11.8	18.7
September.....	50	67	51	59	55	11.9	13.5	13.5	13.0	16.3
October.....	42	56	40	57	40	9.9	11.1	10.7	12.7	11.7
November.....	30	38	30	48	27	7.2	7.7	8.0	10.6	7.9
December.....	28	39	21	47	23	6.7	7.8	5.7	10.5	6.9
January.....	28	42	28	33	26	6.7	8.3	7.5	7.4	7.6
February.....	19	40	20	36	19	4.5	8.0	5.3	8.0	5.6
March.....	23	35	20	23	15	5.5	7.1	5.2	5.0	4.4
April.....	27	33	14	21	13	6.3	6.5	3.8	4.6	3.7
May.....	29	20	17	28	10	7.0	4.0	4.4	6.3	3.1
June.....	28	24	16	22	13	6.7	4.9	4.3	5.0	3.7
Season.....	420	500	375	450	340	100.0	100.0	100.0	100.0	100.0

## BARLEY—Continued.

TABLE 44.—Barley: Area and production in undermentioned countries, 1909–1919—Con.

[000 omitted.]

Country.	Area.				Production.			
	Average 1909– 1913.	1917	1918	1919	Average 1909– 1913.	1917	1918	1919
SOUTH AMERICA.								
	<i>Acres.</i>	<i>Acres.</i>	<i>Acres.</i>	<i>Acres.</i>	<i>Bushels.</i>	<i>Bushels.</i>	<i>Bushels.</i>	<i>Bushels.</i>
Argentina.....	268	388	(1)	(1)	3,626	2,165	(1)	(1)
Chile.....	117	125	98	98	3,924	4,840	3,304	3,977
Uruguay.....	4	13	6	(1)	61	110	108	(1)
Total.....	389	526	.....	.....	7,611	7,115	.....	.....
EUROPE.								
Austria <sup>2</sup> .....	2,712	(1)	(1)	(1)	71,988	(1)	(1)	(1)
Hungary proper <sup>2</sup> .....	2,760	(1)	(1)	(1)	69,812	(1)	(1)	(1)
Croatia-Slavonia <sup>2</sup> .....	158	(1)	(1)	(1)	2,540	(1)	(1)	(1)
Bosnia-Herzegovina <sup>2</sup> .....	214	(1)	(1)	(1)	3,455	(1)	(1)	(1)
Belgium.....	85	(1)	(1)	75	4,247	(1)	(1)	3,617
Bulgaria <sup>2</sup> .....	616	(1)	(1)	(1)	12,425	<sup>3</sup> 14,739	(1)	(1)
Denmark.....	591	592	548	569	22,589	17,881	21,465	(1)
Finland.....	(1)	(1)	(1)	(1)	5,737	(1)	(1)	(1)
France <sup>2</sup> .....	1,866	<sup>4</sup> 1,699	<sup>4</sup> 1,371	1,340	46,489	<sup>4</sup> 37,265	<sup>4</sup> 27,475	23,626
Germany <sup>2</sup> .....	3,976	<sup>5</sup> 3,738	<sup>5</sup> 3,640	(1)	153,529	<sup>5</sup> 89,886	<sup>5</sup> 103,720	(1)
Italy.....	613	469	494	479	10,104	7,422	9,186	8,327
Luxemburg.....	(1)	7	7	(1)	(1)	154	136	(1)
Netherlands.....	68	52	60	59	3,270	2,573	2,615	2,688
Norway.....	89	116	156	156	2,867	4,021	5,622	<sup>3</sup> 5,787
Roumania.....	<sup>2</sup> 1,319	(1)	<sup>6</sup> 2,120	<sup>6</sup> 1,827	<sup>2</sup> 24,821	(1)	<sup>6</sup> 4,993	(1)
Russia proper <sup>2</sup> .....	23,075	(1)	(1)	(1)	372,856	(1)	(1)	(1)
Poland <sup>2</sup> .....	1,249	(1)	(1)	(1)	27,150	(1)	(1)	(1)
Northern Caucasia <sup>2</sup> .....	3,735	(1)	(1)	(1)	67,191	(1)	(1)	(1)
Serbia <sup>2</sup> .....	242	(1)	(1)	(1)	5,072	(1)	(1)	(1)
Spain.....	3,509	4,086	4,209	4,100	74,689	76,747	90,496	74,432
Sweden.....	451	438	452	(1)	14,592	12,263	12,947	(1)
United Kingdom:								
England.....	1,400	1,365	1,395	(1)	47,352	42,897	45,328	(1)
Wales.....	88	95	106	(1)	2,812	2,781	3,312	(1)
Scotland.....	191	159	153	174	7,103	5,816	5,416	6,083
Ireland.....	165	177	185	(1)	7,493	7,796	8,024	(1)
Total United Kingdom.....	1,844	1,796	1,839	.....	64,760	59,290	62,080	.....
Total.....	49,172	.....	.....	.....	1,060,183	.....	.....	.....
ASIA.								
British India.....	7,836	7,883	<sup>7</sup> 8,323	(1)	40,973	155,447	<sup>7</sup> 155,307	(1)
Cyprus.....	(1)	(1)	(1)	(1)	2,151	<sup>3</sup> 1,954	(1)	(1)
Japanese Empire:								
Japan.....	3,183	2,888	2,862	2,931	89,528	88,896	82,650	91,500
Formosa.....	5	(1)	(1)	(1)	53	(1)	(1)	(1)
Korea.....	(1)	(1)	(1)	(1)	(1)	(1)	27,751	26,480
Total Japanese Empire.....	3,188	.....	.....	.....	89,581	.....	.....	.....
Russia:								
Central Asia (4 gov- ernments) <sup>2</sup> .....	368	(1)	(1)	(1)	5,119	(1)	(1)	(1)
Siberia (4 gov- ernments) <sup>2</sup> .....	459	(1)	(1)	(1)	6,027	(1)	(1)	(1)
Transcaucasia (1 gov- ernment) <sup>2</sup> .....	2	(1)	(1)	(1)	25	(1)	(1)	(1)
Total.....	11,853	.....	.....	.....	143,876	.....	.....	.....

<sup>1</sup> No official statistics.<sup>2</sup> Old boundaries.<sup>3</sup> Unofficial estimate.<sup>4</sup> Excludes territory that was occupied by the enemy.<sup>5</sup> Excluding Alsace-Lorraine.<sup>6</sup> Including Bessarabia but excluding Dobrudja.<sup>7</sup> Incomplete.

BARLEY—Continued.

TABLE 44.—Barley: Area and production in undermentioned countries, 1909–1919—Con.

[000 omitted.]

Country.	Area.				Production.			
	Average 1909–1913.	1917	1918	1919	Average 1909–1913.	1917	1918	1919
<b>AFRICA.</b>								
	<i>Acres.</i>	<i>Acres.</i>	<i>Acres.</i>	<i>Acres.</i>	<i>Bushels.</i>	<i>Bushels.</i>	<i>Bushels.</i>	<i>Bushels.</i>
Algeria.....	3,353	2,839	2,794	2,639	41,961	28,529	60,742	33,667
Egypt.....	394	445	336	357	( <sup>1</sup> )	13,598	9,871	( <sup>1</sup> )
Tunis.....	1,145	1,038	1,197	977	7,900	8,267	13,090	6,110
Union of South Africa....	( <sup>1</sup> )	57	58	55	2,015	1,000	( <sup>1</sup> )	( <sup>1</sup> )
Total.....	4,892	4,379	4,385	4,028	51,876	51,394	.....	.....
<b>AUSTRALASIA.</b>								
Australia:								
Queensland.....	7	13	( <sup>1</sup> )	( <sup>1</sup> )	119	250	( <sup>1</sup> )	( <sup>1</sup> )
New South Wales.....	12	5	( <sup>1</sup> )	( <sup>1</sup> )	204	73	( <sup>1</sup> )	( <sup>1</sup> )
Victoria.....	60	93	( <sup>1</sup> )	( <sup>1</sup> )	1,400	1,800	( <sup>1</sup> )	( <sup>1</sup> )
South Australia.....	46	104	( <sup>1</sup> )	( <sup>1</sup> )	842	1,734	( <sup>1</sup> )	( <sup>1</sup> )
Western Australia.....	6	11	( <sup>1</sup> )	( <sup>1</sup> )	70	134	( <sup>1</sup> )	( <sup>1</sup> )
Tasmania.....	6	5	( <sup>1</sup> )	( <sup>1</sup> )	184	89	( <sup>1</sup> )	( <sup>1</sup> )
Total Australia.....	137	231	.....	.....	2,819	4,080	.....	.....
New Zealand.....	39	30	* 19	19	1,402	738	569	709
Total Australasia.....	176	261	.....	.....	4,221	4,818	.....	.....
Grand total.....	75,784	.....	.....	.....	1,504,846	.....	.....	.....

<sup>1</sup> No official statistics.

TABLE 45.—Barley: Total production of countries named in Table 44, 1895–1916.

Year.	Production.	Year.	Production.	Year.	Production.	Year.	Production.
	<i>Bushels.</i>		<i>Bushels.</i>		<i>Bushels.</i>		<i>Bushels.</i>
1895.....	915,504,000	1901.....	1,072,195,000	1907.....	1,271,237,000	1913.....	1,650,265,000
1896.....	932,100,000	1902.....	1,229,132,000	1908.....	1,274,897,000	1914.....	1,463,289,000
1897.....	864,605,000	1903.....	1,235,786,000	1909.....	1,458,263,000	1915.....	1,522,732,000
1898.....	1,030,581,000	1904.....	1,175,784,000	1910.....	1,388,734,000	1916.....	1,529,031,000
1899.....	965,720,000	1905.....	1,180,053,000	1911.....	1,373,286,000		
1900.....	959,622,000	1906.....	1,296,579,000	1912.....	1,466,977,000		

TABLE 46.—Barley: Average yield per acre in undermentioned countries, 1890–1919.

Year.	United States.	Russia (European). <sup>1</sup>	Germany. <sup>1</sup>	Austria. <sup>1</sup>	Hungary proper. <sup>1</sup>	France. <sup>2</sup>	United Kingdom. <sup>2</sup>
Average:	<i>Bushels.</i>	<i>Bushels.</i>	<i>Bushels.</i>	<i>Bushels.</i>	<i>Bushels.</i>	<i>Bushels.</i>	<i>Bushels.</i>
1890–1899.....	23.4	13.3	29.4	21.1	.....	22.6	39.8
1900–1909.....	25.5	14.3	35.3	26.3	23.4	23.6	35.0
1910–1914.....	24.6	15.7	38.0	29.1	25.0	24.6	34.4
1906.....	28.3	13.0	35.2	26.1	26.8	20.8	36.1
1907.....	23.8	14.2	38.2	27.3	23.1	24.4	36.8
1908.....	35.1	14.2	34.9	25.2	21.3	22.6	34.9
1909.....	22.5	17.9	39.5	28.4	25.1	25.4	38.9
1910.....	22.5	16.3	34.4	24.9	19.7	23.5	34.3
1911.....	21.0	14.4	37.0	27.5	26.9	25.0	34.0
1912.....	29.7	16.2	40.7	29.7	26.9	26.1	33.1
1913.....	23.8	18.5	41.3	29.7	27.6	24.5	35.1
1914.....	25.8	12.9	36.8	33.8	24.1	24.0	35.6
1915.....	32.0	14.7	28.4	18.8	19.7	19.7	31.8
1916.....	23.6	.....	<sup>3</sup> 34.2	.....	.....	23.8	33.0
1917.....	23.7	.....	.....	.....	.....	<sup>1</sup> 26.8	33.9
1918.....	26.5	.....	.....	.....	.....	20.8	34.0
1919.....	22.3	.....	.....	.....	.....	.....	.....

<sup>1</sup> Bushels of 48 pounds.

<sup>2</sup> Winchester bushels.

<sup>3</sup> Excluding Alsace-Lorraine.

## BARLEY—Continued.

TABLE 47.—Barley: Acreage, production, value, exports, etc., in the United States, 1849-1919.

NOTE.—Figures in *italics* are census returns; figures in roman are estimates of the Department of Agriculture. Estimates of acres are obtained by applying estimated percentages of increase or decrease to the published numbers of the preceding year, except that a revised base is used for applying percentage estimates whenever new census data are available.

Year.	Acreage.	Average yield per acre.	Production.	Average farm price per bushel Dec. 1.	Farm value Dec. 1.	Chicago cash price per bushel, low malting to fancy. <sup>1</sup>				Domestic exports, fiscal year beginning July 1.	Imports, fiscal year beginning July 1.
						December.		Following May.			
						Low.	High.	Low.	High.		
1849			<i>5,167,000</i>								
1859			<i>15,826,000</i>								
1866	493,000	22.9	11,284,000	70.2	7,916,000	59	70	85	100		3,247,250
1867	1,131,000	22.7	25,727,000	70.1	18,028,000	150	180	227	250	9,810	3,783,966
1868	937,000	24.4	22,896,000	109.0	24,948,000	140	170	149	175	9,077	5,069,880
1869	1,026,000	27.9	28,652,000	70.8	20,298,000	74	85	50	62	255,490	6,727,597
1869			<i>29,761,000</i>								
1870	1,109,000	23.7	26,295,000	79.1	20,792,000	68	80	72	95	340,093	4,866,700
1871	1,114,000	24.0	26,718,000	75.8	20,264,000	55½	64	55	71	86,891	5,565,591
1872	1,397,000	19.2	26,846,000	68.6	18,416,000	60	70	71	85	482,410	4,244,751
1873	1,387,000	23.1	32,044,000	86.7	27,794,000	132	158	130	155	320,399	4,891,189
1874	1,581,000	20.6	32,552,000	86.0	27,998,000	120	129½	115	137	91,118	6,255,063
1875	1,790,000	20.6	36,909,000	74.1	27,368,000	81	88	62½	72½	317,781	10,285,957
1876	1,767,000	21.9	38,710,000	63.0	24,403,000	63½	68½	80	85	1,186,129	6,702,965
1877	1,669,000	21.4	35,638,000	62.5	22,287,000	56½	64	46½	52½	3,921,501	6,764,228
1878	1,790,000	23.6	42,246,000	57.9	24,454,000	91	100	64	73	715,536	5,720,979
1879	1,681,000	24.0	40,283,000	58.9	23,714,000	86	92	75	80	1,128,923	7,135,258
1879	<i>1,998,000</i>	<i>22.0</i>	<i>43,997,000</i>								
1880	1,843,000	24.5	45,165,000	66.6	30,091,000	100	120	95	105	885,246	9,528,616
1881	1,968,000	20.9	41,161,000	82.3	33,863,000	101	107	100	100	205,930	2,182,722
1882	2,272,000	21.5	48,954,000	62.9	30,768,000	79	82	80	80	433,005	10,050,687
1883	2,379,000	21.1	50,136,000	58.7	29,420,000	62	67	65	74	724,955	8,596,122
1884	2,609,000	23.5	61,203,000	48.7	29,779,000	53	58	65	65	629,130	9,986,507
1885	2,729,000	21.4	58,360,000	56.3	32,868,000	62	65	58	60	252,183	10,197,115
1886	2,653,000	22.4	59,428,000	53.6	31,841,000	51	54	57	57	1,305,300	10,355,594
1887	2,902,000	19.6	56,812,000	51.9	29,464,000	80	80	69	77	550,884	10,831,461
1888	2,996,000	21.3	63,884,000	59.0	37,672,000					1,440,321	11,368,414
1889	3,221,000	24.3	78,333,000	41.6	32,614,000	58	58			1,408,311	11,332,545
1889	<i>3,221,000</i>	<i>24.3</i>	<i>78,333,000</i>								
1890	3,135,000	21.4	67,168,000	62.7	42,141,000					973,062	5,078,733
1891	3,353,000	25.9	86,839,000	52.4	45,470,000					2,800,075	3,146,328
1892	3,400,000	23.6	80,097,000	47.5	38,026,000	65	67	65	65	3,035,267	1,970,129
1893	3,220,000	21.7	69,869,000	41.1	28,729,000	52	54	55	60	5,219,405	791,061
1894	3,171,000	19.4	61,400,000	44.2	27,134,000	53½	55½	51	52	1,563,754	2,116,816
1895	3,300,000	26.4	87,073,000	33.7	29,312,000	33	40	25	36	7,680,331	837,384
1896	2,951,000	23.6	69,695,000	32.3	22,491,000	22	37	24½	35	20,030,301	1,271,787
1897	2,719,000	24.5	66,685,000	37.7	25,142,000	25½	42	36	53	11,237,077	124,804
1898	2,583,000	21.6	55,792,000	41.3	23,064,000	40	50½	36	42	2,267,403	110,475
1899	2,878,000	25.5	73,382,000	40.3	29,594,000	35	45	36	44	23,661,662	189,757
1899	<i>4,470,000</i>	<i>26.8</i>	<i>119,635,000</i>								
1900	2,894,000	20.4	58,926,000	40.9	24,075,000	37	61	37	57	6,293,207	171,004
1901	4,296,000	25.6	109,933,000	45.2	49,705,000	56	63	64	72	8,714,268	57,406
1902	4,661,000	29.0	134,954,000	45.9	61,899,000	36	70	48	56	8,429,141	56,462
1903	4,993,000	26.4	131,861,000	45.6	60,166,000	42	61½	38	59	10,881,627	90,708
1904	5,146,000	27.2	139,749,000	42.0	58,652,000	38	52	40	50	10,661,655	81,020
1905	5,096,000	26.8	136,551,000	40.5	54,993,000	37	53	42	55½	17,729,360	18,049
1906	6,324,000	28.3	178,916,000	41.5	74,236,000	44	56	66	85	8,238,842	38,319
1907	6,448,000	23.8	153,597,000	66.6	102,290,000	78	102	60	75	4,349,078	199,741
1908	6,646,000	25.1	166,756,000	55.4	92,442,000	57	64½	66	75	6,580,393	2,644
1909	7,011,000	24.3	170,284,000								
1909	<i>7,699,000</i>	<i>22.5</i>	<i>173,344,000</i>	54.0	93,539,000	55	72	50	68	4,311,566	
1910 <sup>2</sup>	7,743,000	22.5	173,832,000	57.8	100,426,000	72	90	75	115	9,399,346	
1911	7,627,000	21.0	160,240,000	86.9	139,182,000	102	130	68	132	1,585,242	
1912	7,530,000	29.7	223,824,000	50.5	112,957,000	43	77	45	68	17,536,703	
1913	7,499,000	23.8	178,189,000	53.7	95,731,000	50	79	51	66	6,644,747	
1914	7,565,000	25.8	194,953,000	54.3	105,903,000	60	75	74½	82	26,754,522	
1915	7,148,000	32.0	228,851,000	51.6	118,172,000	62	77	70	83	27,473,160	
1916	7,757,000	23.5	182,309,000	88.1	160,646,000	95	125	128	165	16,381,077	
1917	8,933,000	23.7	211,759,000	113.7	240,758,000	125	163	105	176	26,285,378	
1918	9,740,000	26.3	256,225,000	91.7	234,942,000	88	105	110	130	23,381,781	
1919	7,420,000	22.3	165,719,000	120.9	200,419,000	125	168				

<sup>1</sup> Prices 1895 to 1908 for No. 3 grade.<sup>2</sup> Figures adjusted to census basis.



BARLEY—Continued.

TABLE 48.—Barley: Revised acreage, production, and farm value, 1879 and 1889–1909.

[See headnote of Table 4.]

Year.	Acreage.	Average yield per acre.	Production.	Average farm price per bushel Dec. 1.	Farm value Dec. 1.
	<i>Acres.</i>	<i>Bushels.</i>	<i>Bushels.</i>	<i>Cents.</i>	<i>Dollars.</i>
1879.....	1,998,000	24.4	48,721,000	59.4	28,928,000
1889.....	3,221,000	24.3	78,213,000	41.6	32,574,000
1890.....	3,406,090	21.4	73,017,000	62.6	45,719,090
1891.....	3,705,000	26.1	96,589,000	51.8	50,051,000
1892.....	3,892,000	23.6	92,037,000	46.5	42,790,000
1893.....	3,855,000	21.7	83,700,000	40.5	33,922,000
1894.....	4,005,000	19.5	78,051,000	43.5	33,924,000
1895.....	4,263,000	26.9	114,732,000	32.0	36,678,000
1896.....	4,172,000	23.8	99,394,000	30.0	29,814,000
1897.....	4,150,000	24.9	103,279,000	35.2	36,346,000
1898.....	4,237,000	23.5	99,490,000	38.9	38,701,000
1899.....	4,470,000	26.1	116,552,000	39.0	45,479,000
1900.....	4,545,000	21.1	96,041,000	40.5	38,896,000
1901.....	4,742,000	25.7	121,784,000	45.2	55,068,000
1902.....	5,126,000	29.1	149,389,000	45.5	67,944,000
1903.....	5,568,000	26.4	146,864,000	45.4	66,700,000
1904.....	5,912,000	27.4	162,105,000	41.6	67,427,000
1905.....	6,250,000	27.2	170,174,000	39.4	67,005,000
1906.....	6,730,000	28.6	192,270,000	41.6	80,069,000
1907.....	6,941,000	24.5	170,008,000	66.3	112,675,000
1908.....	7,294,000	25.3	184,857,000	55.2	102,037,000
1909.....	7,699,000	24.4	187,973,000	54.8	102,947,000

TABLE 49.—Barley: Acreage, production, and total farm value, by States, 1919.

[000 omitted.]

State.	Acreage.	Production.	Farm value. Dec. 1.	State.	Acreage.	Production.	Farm value. Dec. 1.
	<i>Acres.</i>	<i>Bushels.</i>	<i>Dollars.</i>		<i>Acres.</i>	<i>Bushels.</i>	<i>Dollars.</i>
Maine.....	6	168	286	Kansas.....	600	16,200	16,200
New Hampshire.....	1	25	47	Kentucky.....	4	100	157
Vermont.....	14	420	630	Tennessee.....	8	176	317
New York.....	113	2,486	3,381	Texas.....	25	875	980
Pennsylvania.....	16	392	502	Oklahoma.....	50	1,500	1,830
Maryland.....	6	198	244	Montana.....	90	540	756
Virginia.....	15	375	488	Wyoming.....	35	525	919
Ohio.....	125	3,150	3,938	Colorado.....	200	3,900	4,680
Indiana.....	55	1,430	1,687	New Mexico.....	20	680	748
Illinois.....	212	5,724	6,926	Arizona.....	29	1,102	1,543
Michigan.....	280	5,320	6,278	Utah.....	24	720	1,015
Wisconsin.....	512	13,568	16,417	Nevada.....	12	420	630
Minnesota.....	910	18,200	21,112	Idaho.....	120	3,360	4,704
Iowa.....	315	8,032	8,996	Washington.....	138	4,140	5,589
Missouri.....	11	330	429	Oregon.....	82	1,886	2,829
North Dakota.....	1,300	14,950	16,146	California.....	1,000	30,000	42,306
South Dakota.....	875	19,250	22,138				
Nebraska.....	217	5,577	5,577	United States.....	7,420	165,719	200,419

## BARLEY—Continued.

TABLE 50.—Barley: Yield per acre, price per bushel Dec. 1, and value per acre, by States.

State.	Yield per acre (bushels).											Farm price per bushel (cents).					Value per acre (dollars). <sup>1</sup>		
	10-year average, 1910-1919.	1910	1911	1912	1913	1914	1915	1916	1917	1918	1919	10-year average, 1910-1919.	1915	1916	1917	1918	1919	5-year average, 1914-1918.	1919
	Me.	27.0	31.0	28.0	26.2	28.0	30.0	26.5	26.0	21.0	25.0	28.0	103	75	104	130	149	170	27.15
N. H.	27.8	26.0	24.0	28.0	28.0	32.0	30.0	28.0	25.0	32.0	25.0	109	79	90	175	150	188	33.38	47.00
Vt.	31.6	31.0	30.5	35.0	32.0	34.5	35.0	27.5	29.0	31.0	30.0	100	75	100	140	153	150	33.53	45.00
N. Y.	27.1	28.3	25.0	26.0	26.7	28.0	32.0	23.3	28.0	31.5	22.0	94	75	101	130	126	136	28.70	29.92
Pa.	26.8	26.5	25.0	27.5	26.0	28.0	29.5	25.0	28.0	28.0	24.5	88	75	75	140	120	128	26.65	31.36
Md.	29.8	31.0	23.0	27.0	29.0	33.0	34.0	32.0	25.0	31.0	33.0	84	70	73	130	120	123	27.73	40.59
Va.	26.8	29.3	23.0	25.0	26.0	26.0	29.0	27.5	30.0	27.0	25.0	95	75	85	139	160	130	30.17	32.50
Ohio	28.4	28.5	27.2	31.0	24.0	25.0	31.0	27.8	33.0	31.5	25.2	79	54	80	118	93	125	24.39	31.50
Ind.	28.2	27.0	26.5	29.5	25.0	25.0	28.0	27.0	30.5	37.0	26.0	77	65	75	104	104	118	25.08	30.68
Ill.	31.2	30.2	28.0	31.5	26.0	29.5	34.0	32.0	37.5	36.0	27.0	81	57	103	121	90	121	29.62	32.67
Mich.	25.4	26.0	24.0	26.0	24.8	26.0	29.5	24.5	24.4	30.0	19.0	82	62	91	119	100	118	23.31	22.42
Wis.	29.3	25.9	25.5	29.4	25.0	27.3	35.5	30.0	32.0	35.7	26.5	84	56	105	124	92	121	28.17	32.06
Minn.	24.3	21.0	19.0	28.2	24.0	23.0	30.5	19.0	27.0	31.0	20.0	74	49	87	111	80	116	19.69	23.20
Iowa	28.6	29.5	21.9	31.0	25.0	26.0	31.0	29.5	35.0	31.5	25.5	76	49	91	117	85	112	24.81	28.56
Mo.	24.3	27.0	20.0	24.8	22.0	24.0	25.0	20.0	25.0	25.0	30.0	82	63	93	94	115	130	20.44	39.00
N. Dak.	18.7	5.5	19.5	29.9	20.0	19.5	32.0	15.5	12.5	21.5	11.5	66	44	80	100	73	108	12.69	12.42
S. Dak.	22.3	18.2	5.4	26.0	17.5	23.0	32.0	22.7	27.0	29.5	22.0	72	46	83	110	78	115	19.55	25.30
Nebr.	21.9	18.5	11.0	22.0	16.0	23.5	31.0	28.0	26.5	16.5	25.7	64	42	75	98	85	100	17.01	25.70
Kans.	17.3	18.0	6.5	23.5	8.1	24.5	31.0	16.0	8.0	10.0	27.0	68	42	77	115	95	100	11.11	27.00
Ky.	27.1	24.0	28.7	26.0	26.6	28.5	30.0	26.0	28.0	28.0	25.0	95	77	90	115	140	157	27.97	39.25
Tenn.	23.7	23.0	28.0	26.0	25.0	27.0	24.0	23.7	15.0	23.0	22.0	105	75	100	144	152	180	24.08	39.60
Texas	24.3	30.0	18.0	29.3	24.0	25.0	28.0	17.0	20.0	17.0	35.0	94	68	80	137	130	112	19.93	39.20
Okla.	19.8	30.0	10.0	20.0	9.0	25.0	26.5	12.5	18.0	17.0	30.0	84	50	100	148	124	122	17.34	36.65
Mont.	26.6	28.0	34.5	36.5	31.0	30.5	34.0	28.0	15.0	22.0	6.0	75	48	76	103	100	140	18.24	8.40
Wyo.	31.8	30.0	34.0	34.0	30.5	33.0	36.0	33.0	36.0	37.0	15.0	91	55	87	130	130	175	32.91	26.20
Colo.	31.0	32.0	29.0	39.0	32.5	38.5	36.0	32.0	33.0	18.0	19.5	76	48	82	104	113	120	23.87	23.40
N. Mex.	30.2	25.0	33.0	35.0	24.0	34.0	33.0	28.0	28.0	28.0	34.0	90	70	100	139	110	110	29.26	37.40
Ariz.	36.6	36.0	36.5	40.0	39.0	36.0	37.0	35.0	35.0	34.0	38.0	98	56	108	150	130	140	35.36	53.20
Utah	38.8	36.0	43.0	45.0	38.5	45.0	42.5	36.0	37.0	35.0	30.0	82	52	76	120	140	141	33.07	42.30
Nev.	40.2	40.0	40.0	41.0	41.0	47.0	48.0	41.0	35.0	34.0	35.0	98	70	95	119	154	150	39.42	52.50
Idaho	36.3	33.0	42.0	43.5	42.0	38.0	40.5	39.0	29.0	28.0	28.0	78	52	82	105	130	140	27.78	39.20
Wash.	34.6	29.0	37.0	43.0	40.5	39.0	41.5	41.3	29.0	15.2	30.0	79	56	84	115	115	135	25.81	40.50
Oreg.	31.8	31.5	34.0	36.0	35.0	30.0	36.0	38.5	29.0	25.0	23.0	84	62	80	115	136	150	27.75	34.50
Calif.	28.7	31.0	28.0	30.0	26.0	30.0	29.0	28.0	29.0	26.0	30.0	87	62	95	120	115	141	25.40	42.30
U. S.	25.1	22.5	21.0	29.7	23.8	25.8	32.0	23.5	23.7	26.3	22.3	76.9	51.6	88.1	113.7	91.7	120.9	20.46	27.01

<sup>1</sup> Based upon farm price Dec. 1.

TABLE 51.—Barley: Condition of crop, United States, on first of months named, 1898-1919.

Year.	June.	July.	August.	When harvested.	Year.	June.	July.	August.	When harvested.
	<i>P. ct.</i>	<i>P. ct.</i>	<i>P. ct.</i>	<i>P. ct.</i>		<i>P. ct.</i>	<i>P. ct.</i>	<i>P. ct.</i>	<i>P. ct.</i>
1898	78.8	85.7	79.3	79.2	1909	90.6	90.2	85.4	80.5
1899	91.4	92.0	93.6	86.7	1910	89.6	73.7	70.0	69.8
1900	86.2	76.3	71.6	70.7	1911	90.2	72.1	66.2	65.5
1901	91.0	91.3	86.9	83.8	1912	91.1	88.3	89.1	88.9
1902	93.6	93.7	90.2	89.7	1913	87.1	76.6	74.9	73.4
1903	91.5	86.8	83.4	82.1	1914	95.5	92.6	85.3	82.4
1904	90.5	88.5	88.1	87.4	1915	94.6	94.1	93.8	94.2
1905	93.7	91.5	89.5	87.8	1916	86.3	87.9	80.0	74.6
1906	93.5	92.5	90.3	89.4	1917	89.3	85.4	77.9	76.3
1907	84.9	84.4	84.5	78.5	1918	90.5	84.7	82.0	81.5
1908	89.7	86.2	83.1	81.2	1919	91.7	87.4	73.6	69.2

BARLEY—Continued.

TABLE 52.—Barley: Farm price, cents per bushel on first of each month, 1910–1919.

Date.	1919	1918	1917	1916	1915	1914	1913	1912	1911	1910	Average.
Jan. 1.....	91.3	126.5	87.1	54.9	54.3	52.2	49.9	86.4	59.8	57.6	72.0
Feb. 1.....	86.8	131.9	92.7	61.7	62.9	52.4	51.4	91.2	64.1	59.3	75.4
Mar. 1.....	85.4	161.1	96.9	59.6	67.7	51.1	49.0	91.0	63.0	60.2	78.5
Apr. 1.....	92.7	170.2	102.3	57.2	64.7	51.7	48.5	92.3	69.1	59.7	80.8
May 1.....	103.9	158.5	120.1	59.6	63.8	49.3	48.3	96.2	74.0	56.5	83.0
June 1.....	109.2	135.4	119.3	59.6	62.0	49.1	52.7	91.1	73.8	55.7	80.8
July 1.....	108.4	118.4	106.6	59.3	55.8	47.5	53.7	81.9	70.1	53.9	75.6
Aug. 1.....	118.7	110.0	114.5	59.3	56.7	45.1	50.8	66.8	69.3	54.7	74.6
Sept. 1.....	115.6	100.9	110.0	72.9	51.9	52.5	55.2	53.5	77.0	57.2	74.7
Oct. 1.....	115.3	95.5	113.9	76.5	46.8	51.8	56.8	54.8	81.7	56.1	74.9
Nov. 1.....	117.1	94.9	111.3	83.2	50.1	51.7	54.7	53.8	84.9	55.3	75.7
Dec. 1.....	120.9	91.7	113.7	88.1	51.6	54.3	53.7	50.5	86.9	57.8	76.9
Average.....	108.9	112.6	107.7	71.0	54.1	51.5	53.3	66.9	75.2	56.9	75.8

TABLE 53.—Barley: Wholesale price per bushel, 1913–1919.

Date.	Cincinnati.			Chicago.			Milwaukee.			Minneapolis.			San Francisco.		
	Spring malt. <sup>1</sup>			Low malting to fancy. <sup>2</sup>			No. 3. <sup>3</sup>			All grades.			Feed (per 100 pounds).		
	Low.	High.	Average.	Low.	High.	Average.	Low.	High.	Average.	Low.	High.	Average.	Low.	High.	Average.
1913.	Cts.	Cts.	Cts.	Cts.	Cts.	Cts.	Cts.	Cts.	Cts.	Cts.	Cts.	Cts.	Cts.	Cts.	Cts.
January–June.....	70	86	79.1	42	71	57.0	53	73	61.8	39	63	50.9	128	150	137.0
July–December.....	87	92	89.5	43	85	66.2	58	60	68.4	42	73	56.9	123½	142½	132.0
1914.															
January–June.....	60	70	64.5	49	79	60.6	53	68	61.0	41	65	51.1	90	132½	109.2
July–December.....	70	80	75.3	50	82	65.6	51½	82	67.9	40	76	56.6	95	130	110.0
1915.															
January–June.....	72	102	83.9	66	91	78.1	70½	93	78.9	58	86	70.7	100	162½	131.6
July–December.....	70	102	83.0	51	85	65.6	54	81	66.9	42	78	58.9	100	132½	121.7
1916.															
January–June.....	83	102	93.8	64	86	74.6	68	82	75.7	59	76½	67.4	127½	136½	131.7
July–December.....	93	145	124.2	68	128	99.4	70	128	106.3	57	112	82.4	127½	225	178.3
1917.															
January–June.....	135	182	161.3	102	165	130.4	120½	166	139.2	85	155	114.6	215	305	236.3
July–December.....	147	185	168.3	112	163	136.2	120	162	139.5	88	160	132.1	205	285	241.3
1918.															
January–June.....	172	256	205.8	100	243	163.0	115	239	171.2	85	237	154.3	280	350	315.5
July–December.....	108	208	153.2	80	128	99.9	93	125	105.8	80	130	94.4	210	222½	215.7
1919.															
January.....	108	115	112.1	70	109	98.0	88	113	103.0	70	100	88.3	217½	225	222.0
February.....	108	115	112.4	80	100	89.2	90	103½	99.7	71	94	83.1	187½	225	214.1
March.....	108	123	112.1	87½	120	101.1	92	118	103.9	77	105	90.2	185	232	201.4
April.....	120	123	121.5	104	127	114.2	111	130	118.2	94	119	104.0	227½	240	234.0
May.....	125	139	130.8	110	130	118.8	117	133	122.9	100	119	108.4	235	260	243.6
June.....	125	132	128.7	112	128	119.0	115	128	121.2	98	118	108.0	255	290	262.8
January–June.....	108	139	119.6	70	130	106.7	88	133	111.5	70	119	97.0	185	290	229.6
July.....	130	152	136.8	115	143	126.0	123	146	132.4	104	140	119.1	280	320	306.4
August.....	145	152	149.8	132	148	138.6	144	155	148.3	103	142	123.4	317½	322½	320.0
September.....	137	140	138.5	100	140	127.6	135	143	140.3	195	134	114.2	290	305½	299.0
October.....	138	145	142.0	115	143	128.7	119	145	133.7	100	139	117.3	285	317½	298.9
November.....	143	155	149.0	120	158	139.8	132	157	144.1	105	146	126.2	310	350	327.6
December.....	150	165	155.0	125	168	157.3	143	167	157.0	123	162	143.0	332½	350	339.0
July–December.....	130	165	145.2	100	168	136.3	119	167	142.6	100	162	123.9	280	350	315.2

<sup>1</sup> No. 2 spring Jan.–July, 1919; No. 3 spring September, 1919.

<sup>3</sup> No. 4 September, 1919.

<sup>2</sup> Beginning September—all barley.

## BARLEY—Continued.

TABLE 54.—Barley and malt: International trade, calendar years 1911–1913, 1917, and 1918.

[See "General note," Table 12.]

## EXPORTS.

[000 omitted.]

Country.	Barley.			Malt.			Barley and malt in terms of barley.		
	Average 1911–1913	1917 (prelim.)	1918 (prelim.)	Average 1911–1913	1917 (prelim.)	1918 (prelim.)	Average 1911–1913	1917 (prelim.)	1918 (prelim.)
<i>From—</i>	<i>Bushels.</i>	<i>Bushels.</i>	<i>Bushels.</i>	<i>Bushels.</i>	<i>Bushels.</i>	<i>Bushels.</i>	<i>Bushels.</i>	<i>Bushels.</i>	<i>Bushels.</i>
Algeria.....	4,720	2,353	3,743	.....	.....	.....	4,720	2,353	3,743
Argentina.....	917	566	218	.....	.....	.....	917	566	218
Austria-Hungary.....	7,529	.....	.....	11,816	.....	.....	18,271	.....	.....
Belgium.....	3,629	.....	.....	246	.....	.....	3,853	.....	.....
British India.....	17,129	14,531	14,848	.....	.....	.....	17,129	14,531	14,848
Bulgaria.....	1,700	.....	.....	.....	.....	.....	1,700	.....	.....
Canada.....	6,656	7,034	4,046	15	202	561	6,670	7,218	4,556
Chile.....	608	197	.....	25	943	.....	631	1,054	.....
China.....	660	61	97	.....	.....	.....	660	61	97
Denmark.....	3,473	6	357	97	29	.....	3,561	32	357
France.....	609	92	12	33	548	93	639	590	96
Germany.....	139	.....	.....	1,194	.....	.....	1,225	.....	.....
Netherlands.....	28,995	.....	.....	678	.....	.....	29,611	.....	.....
Roumania.....	16,690	.....	.....	3	.....	.....	16,692	.....	.....
Russia.....	168,289	.....	.....	189	.....	.....	168,461	.....	.....
United Kingdom.....	107	11	44	908	513	23	932	478	65
United States.....	8,177	17,859	18,805	244	4,163	896	8,400	21,644	19,620
Other countries.....	15,560	.....	.....	10	.....	.....	15,569	.....	.....
Total.....	285,587	.....	.....	15,458	.....	.....	299,641	.....	.....

## IMPORTS.

<i>Into—</i>									
Argentina.....	3	2	7	1,437	838	965	1,310	764	885
Austria-Hungary.....	838	.....	.....	1	.....	.....	839	.....	.....
Belgium.....	19,546	.....	.....	759	.....	.....	20,236	.....	.....
Brazil.....	1	.....	.....	1,074	.....	.....	978	.....	.....
British South Africa.....	2	( <sup>1</sup> )	( <sup>1</sup> )	383	151	37	351	167	41
Canada.....	33	3	1	147	37	7	166	36	8
Cuba.....	278	437	273	.....	.....	.....	278	437	273
Denmark.....	2,041	466	12	62	.....	.....	2,098	466	12
Egypt.....	690	12	( <sup>1</sup> )	218	67	1	889	73	1
France.....	6,993	9,060	10,686	178	418	370	7,155	9,440	11,022
Finland.....	311	.....	.....	237	.....	.....	526	.....	.....
Germany.....	150,706	.....	.....	3,122	.....	.....	153,544	.....	.....
Italy.....	815	1,229	7,510	.....	331	104	815	1,530	7,604
Netherlands.....	37,646	.....	.....	3,893	.....	.....	41,184	.....	.....
Norway.....	4,218	2,115	.....	126	154	.....	4,333	2,255	.....
Russia.....	940	.....	.....	37	.....	.....	974	.....	.....
Switzerland.....	1,143	729	605	3,626	825	11	4,440	1,479	616
United Kingdom.....	51,636	21,313	11,725	100	163	.....	51,727	21,462	11,725
Other countries.....	1,751	.....	.....	556	.....	.....	2,253	.....	.....
Total.....	279,591	.....	.....	15,956	.....	.....	294,096	.....	.....

<sup>1</sup> Less than 500 bushels.

RYE.

TABLE 55.—Rye: Area and production in undermentioned countries, 1909–1919.

[000 omitted.]

Country.	Area.				Production.			
	Average 1909– 1913. <sup>1</sup>	1917	1918	1919	Average 1909– 1913. <sup>1</sup>	1917	1918	1919
NORTH AMERICA.								
United States.....	<i>Acres.</i> 2,236	<i>Acres.</i> 4,317	<i>Acres.</i> 6,391	<i>Acres.</i> 7,063	<i>Bushels.</i> 34,916	<i>Bushels.</i> 62,933	<i>Bushels.</i> 91,041	<i>Bushels.</i> 88,478
Canada:								
Quebec.....	14	22	29	33	234	376	472	578
Ontario.....	77	68	113	141	1,405	1,207	1,813	2,318
Manitoba.....	5	37	240	299	96	638	3,936	4,783
Saskatchewan.....	3	53	124	190	55	998	1,420	1,667
Alberta.....	12	31	48	84	297	633	826	1,508
Other.....	1	1	1	7	9	5	37	149
Total Canada.....	112	212	555	754	2,096	3,857	8,504	11,003
Mexico.....	( <sup>2</sup> )	( <sup>2</sup> )	( <sup>2</sup> )	( <sup>2</sup> )	70	( <sup>2</sup> )	( <sup>2</sup> )	( <sup>2</sup> )
Total.....	2,348				37,082			
SOUTH AMERICA.								
Argentina.....	68	180	( <sup>2</sup> )	( <sup>2</sup> )	949	858	( <sup>2</sup> )	( <sup>2</sup> )
Chile.....	6	6	8	8	144	92	176	192
Uruguay.....	( <sup>3</sup> )	( <sup>3</sup> )	( <sup>3</sup> )	( <sup>3</sup> )	1	1	1	( <sup>3</sup> )
Total.....	74				1,094	951		
EUROPE.								
Austria <sup>4</sup> .....	5,019	( <sup>2</sup> )	( <sup>2</sup> )	( <sup>2</sup> )	112,752	( <sup>2</sup> )	( <sup>2</sup> )	( <sup>2</sup> )
Hungary proper.....	2,601	( <sup>2</sup> )	( <sup>2</sup> )	( <sup>2</sup> )	48,716	( <sup>2</sup> )	( <sup>2</sup> )	( <sup>2</sup> )
Croatia Slavonia <sup>4</sup> .....	185	( <sup>2</sup> )	( <sup>2</sup> )	( <sup>2</sup> )	2,231	( <sup>2</sup> )	( <sup>2</sup> )	( <sup>2</sup> )
Bosnia-Herzegovina <sup>4</sup> .....	39	( <sup>2</sup> )	( <sup>2</sup> )	( <sup>2</sup> )	444	( <sup>2</sup> )	( <sup>2</sup> )	( <sup>2</sup> )
Belgium.....	644	( <sup>2</sup> )	( <sup>2</sup> )	496	22,675	( <sup>2</sup> )	( <sup>2</sup> )	13,681
Bulgaria <sup>4</sup> .....	530	( <sup>2</sup> )	( <sup>2</sup> )	( <sup>2</sup> )	8,553	<sup>5</sup> 8,490	( <sup>2</sup> )	( <sup>2</sup> )
Denmark.....	632	436	542	559	18,098	8,870	12,726	( <sup>2</sup> )
Finland.....	( <sup>2</sup> )	( <sup>2</sup> )	( <sup>2</sup> )	( <sup>2</sup> )	11,174	( <sup>2</sup> )	( <sup>2</sup> )	( <sup>2</sup> )
France <sup>4</sup> .....	2,960	<sup>6</sup> 1,834	<sup>6</sup> 1,746	1,817	48,647	<sup>6</sup> 24,768	<sup>6</sup> 29,935	27,833
Germany <sup>4</sup> .....	15,387	<sup>7</sup> 13,650	<sup>7</sup> 14,200	( <sup>2</sup> )	445,222	<sup>7</sup> 274,677	<sup>7</sup> 315,301	( <sup>2</sup> )
Italy.....	303	279	272	272	5,328	4,460	4,724	4,571
Luxemburg.....	( <sup>2</sup> )	17	17	( <sup>2</sup> )	( <sup>2</sup> )	292	422	( <sup>2</sup> )
Netherlands.....	557	463	472	481	16,422	11,958	13,022	14,057
Norway.....	37	58	37	37	974	1,159	1,012	<sup>5</sup> 1,063
Roumania.....	<sup>4</sup> 317	( <sup>2</sup> )	<sup>8</sup> 624	<sup>8</sup> 523	<sup>4</sup> 4,652	( <sup>2</sup> )	<sup>8</sup> 1,694	( <sup>2</sup> )
Russia proper.....	64,575	( <sup>2</sup> )	( <sup>2</sup> )	( <sup>2</sup> )	791,333	( <sup>2</sup> )	( <sup>2</sup> )	( <sup>2</sup> )
Poland <sup>4</sup> .....	5,261	( <sup>2</sup> )	( <sup>2</sup> )	( <sup>2</sup> )	90,494	( <sup>2</sup> )	( <sup>2</sup> )	( <sup>2</sup> )
Northern Caucasias <sup>4</sup> .....	547	( <sup>2</sup> )	( <sup>2</sup> )	( <sup>2</sup> )	7,409	( <sup>2</sup> )	( <sup>2</sup> )	( <sup>2</sup> )
Serbia <sup>4</sup> .....	114	( <sup>2</sup> )	( <sup>2</sup> )	( <sup>2</sup> )	1,533	( <sup>2</sup> )	( <sup>2</sup> )	( <sup>2</sup> )
Spain.....	1,987	1,800	1,818	1,822	27,635	24,365	30,445	24,635
Sweden.....	977	815	948	( <sup>2</sup> )	23,859	14,080	19,793	( <sup>2</sup> )
Switzerland.....	( <sup>2</sup> )	55	72	51	( <sup>2</sup> )	1,752	1,850	1,575
United Kingdom.....	61	64	116	122	1,751	( <sup>2</sup> )	( <sup>2</sup> )	( <sup>2</sup> )
Total.....	102,733				1,689,902			
ASIA.								
Russia:								
Central Asia (4 gov- ernments) <sup>4</sup> .....	176	( <sup>2</sup> )	( <sup>2</sup> )	( <sup>2</sup> )	1,001	( <sup>2</sup> )	( <sup>2</sup> )	( <sup>2</sup> )
Siberia (4 govern- ments) <sup>4</sup> .....	2,273	( <sup>3</sup> )	( <sup>3</sup> )	( <sup>3</sup> )	23,647	( <sup>3</sup> )	( <sup>3</sup> )	( <sup>3</sup> )
Transcaucasia (1 gov- ernment) <sup>4</sup> .....	2	( <sup>3</sup> )	( <sup>3</sup> )	( <sup>3</sup> )	15	( <sup>3</sup> )	( <sup>3</sup> )	( <sup>3</sup> )
Total.....	2,451				24,663			

<sup>1</sup> Five-year average, except in a few cases where statistics for 5 years were not available.  
<sup>2</sup> No official statistics.  
<sup>3</sup> Less than 500.  
<sup>4</sup> Old boundaries.  
<sup>5</sup> Unofficial estimate.  
<sup>6</sup> Excluding territory occupied by enemy.  
<sup>7</sup> Excludes Alsace-Lorraine.  
<sup>8</sup> Including Bessarabia, but excluding Dobrudja.

## RYE—Continued.

TABLE 55.—Rye: Area and production in undermentioned countries, 1909-1919—Contd.

[000 omitted.]

Country.	Area.				Production.			
	Average 1909- 1913.	1917	1918	1919	Average 1909- 1913.	1917	1918	1919
AUSTRALASIA.								
Australia:	<i>Acres.</i>	<i>Acres.</i>	<i>Acres.</i>	<i>Acres.</i>	<i>Bushels.</i>	<i>Bushels.</i>	<i>Bushels.</i>	<i>Bushels.</i>
Queensland.....	( <sup>2</sup> )	( <sup>2</sup> )	( <sup>1</sup> )	( <sup>1</sup> )	2	2	( <sup>1</sup> )	( <sup>1</sup> )
New South Wales.....	4	2	( <sup>2</sup> )	( <sup>2</sup> )	49	31	( <sup>2</sup> )	( <sup>2</sup> )
Victoria.....	2	3	( <sup>2</sup> )	( <sup>2</sup> )	24	43	( <sup>2</sup> )	( <sup>2</sup> )
South Australia.....	1	2	( <sup>2</sup> )	( <sup>2</sup> )	10	11	4	( <sup>2</sup> )
Western Australia.....	1	1	( <sup>1</sup> )	( <sup>2</sup> )	5	4	1	( <sup>2</sup> )
Tasmania.....	1	1	( <sup>2</sup> )	( <sup>2</sup> )	18	7	( <sup>2</sup> )	( <sup>2</sup> )
Total Australia.....	9	9	.....	.....	108	98	.....	.....
New Zealand.....	5	( <sup>2</sup> )	( <sup>2</sup> )	( <sup>2</sup> )	97	( <sup>2</sup> )	( <sup>2</sup> )	( <sup>2</sup> )
Total Australasia.....	14	.....	.....	.....	205	.....	.....	.....
Grand total.....	107,620	.....	.....	.....	1,752,946	.....	.....	.....

<sup>1</sup> No official statistics.<sup>2</sup> Less than 500.

TABLE 56.—Rye: Total production of countries in Table 55, 1895-1915.

Year.	Production.	Year.	Production.	Year.	Production.	Year.	Production.
	<i>Bushels.</i>		<i>Bushels.</i>		<i>Bushels.</i>		<i>Bushels.</i>
1895.....	1,468,212,000	1901.....	1,416,022,000	1907.....	1,538,778,000	1913.....	1,889,387,000
1896.....	1,499,250,000	1902.....	1,647,845,000	1908.....	1,590,057,000	1914.....	1,596,882,000
1897.....	1,300,645,000	1903.....	1,659,961,000	1909.....	1,747,123,000	1915.....	1,577,496,000
1898.....	1,461,171,000	1904.....	1,742,112,000	1910.....	1,673,473,000		
1899.....	1,583,179,000	1905.....	1,495,751,000	1911.....	1,753,933,000		
1900.....	1,557,634,000	1906.....	1,433,395,000	1912.....	1,886,517,000		

TABLE 57.—Rye: Average yield per acre in undermentioned countries, 1890-1919.

Year.	United States	Russia (European). <sup>1</sup>	Germany. <sup>1</sup>	Austria. <sup>1</sup>	Hungary proper. <sup>1</sup>	France. <sup>2</sup>	Ireland. <sup>1</sup>
Average:	<i>Bushels.</i>	<i>Bushels.</i>	<i>Bushels.</i>	<i>Bushels.</i>	<i>Bushels.</i>	<i>Bushels.</i>	<i>Bushels.</i>
1890-1899.....	13.9	10.4	20.9	16.1	.....	17.6	25.2
1900-1909.....	15.7	11.5	25.6	19.0	17.6	17.1	27.5
1910-1914.....	16.3	12.5	28.3	22.2	18.5	16.1	29.9
1906.....	16.7	8.8	25.1	19.9	19.8	16.3	27.6
1907.....	16.4	10.8	25.8	18.9	16.0	18.2	27.0
1908.....	16.4	11.0	28.0	22.0	17.5	16.8	29.2
1909.....	13.4	12.6	28.8	22.3	17.8	18.1	30.8
1910.....	16.0	12.3	27.1	21.3	18.9	14.7	30.3
1911.....	15.6	10.5	28.2	20.9	18.7	15.8	29.0
1912.....	16.8	14.3	29.5	23.3	19.4	16.5	30.6
1913.....	16.2	13.5	30.4	22.0	19.6	17.0	30.0
1914.....	16.8	12.1	26.4	23.7	16.1	16.6	29.4
1915.....	17.3	14.6	22.8	16.4	17.5	14.3	29.2
1916.....	15.3	.....	.....	.....	.....	15.4	29.0
1917.....	14.6	.....	.....	.....	.....	<sup>1</sup> 13.7	29.2
1918.....	14.4	.....	.....	.....	.....	17.2	27.0
1919.....	12.9	.....	.....	.....	.....	.....	.....

<sup>1</sup> Bushels of 56 pounds.<sup>2</sup> Winchester bushels.

RYE—Continued.

TABLE 58.—Rye: Acreage, production, value, exports, etc., in the United States, 1849-1919.

NOTE.—Figures in *italics* are census returns; figures in roman are estimates of the Department of Agriculture. Estimates of acres are obtained by applying estimated percentages of increase or decrease to the published numbers of the preceding year, except that a revised base is used for applying percentage estimates whenever new census data are available.

Year.	Acreage harvested.	Average yield per acre.	Production.	Average farm price per bushel Dec. 1.	Farm value Dec. 1.	Chicago cash price per bushel, No. 2.				Domestic exports, including rye flour, fiscal year beginning July 1.
						December.		Following May.		
						Low.	High.	Low.	High.	
<i>Acres.</i>	<i>Bush.</i>	<i>Bushels.</i>	<i>Cents.</i>	<i>Dollars.</i>	<i>Cts.</i>	<i>Cts.</i>	<i>Cts.</i>	<i>Cts.</i>	<i>Bushels.</i>	
1849.....			<i>14,189,000</i>							
1850.....			<i>21,101,000</i>							
1866.....	1,548,000	13.5	20,865,000	82.2	17,150,000			142	150	234,971
1867.....	1,689,000	13.7	<i>23,184,000</i>	100.4	23,281,000	132	157	173	185	564,901
1868.....	1,651,000	13.6	22,505,000	94.9	21,349,000	106½	118	100	115½	92,869
1869.....	1,658,000	13.6	22,528,000	77.0	17,342,000	66	77½	78	83½	199,450
1870.....			<i>16,919,000</i>							
1870.....	1,176,000	13.2	15,474,000	73.2	11,327,000	67	74	81	91	87,174
1871.....	1,070,000	14.4	15,366,000	71.1	10,928,000	62	63½	75	93	832,689
1872.....	1,049,000	14.2	14,889,000	67.6	10,071,000	57½	70	68½	70	611,749
1873.....	1,150,000	13.2	15,142,000	70.3	10,638,000	70	81	91	102	1,923,404
1874.....	1,117,000	13.4	14,991,000	77.4	11,610,000	93	99½	103	107½	267,058
1875.....	1,360,000	13.0	17,722,000	67.1	11,894,000	67	68½	61½	70½	589,159
1876.....	1,468,000	13.9	20,375,000	61.4	12,505,000	65½	73	70	92½	2,234,856
1877.....	1,413,000	15.0	21,170,000	57.6	12,202,000	55½	56½	54	60	4,249,684
1878.....	1,623,000	15.9	25,843,000	52.5	13,566,000	44	44½	47	52	4,877,821
1879.....	1,625,000	14.5	23,639,000	65.6	15,507,000	73½	81	73½	85	2,943,894
1879.....	<i>1,842,000</i>	<i>10.8</i>	<i>19,832,000</i>							
1880.....	1,768,000	13.9	24,541,000	75.6	18,565,000	82	91½	115	118	1,955,155
1881.....	1,789,000	11.6	20,705,000	93.3	19,327,000	96½	98	77	83	1,003,609
1882.....	2,228,000	13.4	29,960,000	61.5	18,439,000	57	58½	62	67	2,206,212
1883.....	2,315,000	12.1	28,059,000	58.1	16,301,000	56½	60	60½	62½	6,247,590
1884.....	2,344,000	12.2	28,640,000	51.9	14,857,000	51	52	68	73	2,974,390
1885.....	2,129,000	10.2	21,756,000	57.9	12,595,000	58½	61	58	61	216,699
1886.....	2,130,000	11.5	24,489,000	53.8	13,181,000	53	54½	54½	56½	377,302
1887.....	2,053,000	10.1	20,693,000	54.5	11,283,000	55½	61½	63	68	94,827
1888.....	2,365,000	12.0	28,415,000	58.8	16,722,000	50	52	39	41½	309,266
1889.....	2,171,000	13.1	28,420,000	42.3	12,010,000	44	45½	49½	54	2,280,975
1889.....	<i>2,172,000</i>	<i>13.1</i>	<i>28,421,000</i>							
1890.....	2,142,000	12.0	25,807,000	62.9	16,230,000	64½	68½	83	92	358,263
1891.....	2,176,000	14.6	31,752,000	77.4	24,589,000	86	92	70½	79	12,068,628
1892.....	2,164,000	12.9	27,979,000	54.2	15,160,000	46	51	50½	62	1,493,924
1893.....	2,038,000	13.0	26,555,000	51.3	13,612,000	45	47½	44½	48	249,152
1894.....	1,945,000	13.7	26,728,000	50.1	13,395,000	47½	49	62½	67	32,045
1895.....	1,890,000	14.4	27,210,000	44.0	11,965,000	32	35½	33	36½	1,011,128
1896.....	1,831,000	13.3	24,369,000	40.9	9,961,000	37	42½	32½	35½	8,575,663
1897.....	1,704,000	16.1	27,363,000	44.7	12,240,000	45½	47	48	75	15,562,035
1898.....	1,643,000	15.6	25,658,000	46.3	11,875,000	52½	55½	56½	62	10,169,822
1899.....	1,659,000	14.4	23,962,000	51.0	12,214,000	49	52	53	56½	2,382,012
1899.....	<i>2,054,000</i>	<i>12.4</i>	<i>25,559,000</i>							
1900.....	1,591,000	15.1	23,996,000	51.2	12,295,000	45½	49½	51½	54	2,345,512
1901.....	1,988,000	15.3	30,345,000	55.7	16,910,000	59	65½	54½	58	2,712,077
1902.....	1,979,000	17.0	33,631,000	50.8	17,081,000	48	49½	48	50½	5,445,273
1903.....	1,907,000	15.4	29,363,000	54.5	15,994,000	50½	52½	69½	78	784,068
1904.....	1,793,000	15.2	27,242,000	68.8	18,748,000	73	75	70	84	29,749
1905.....	1,730,000	16.5	28,486,000	61.1	17,414,000	64	68	58	62	1,387,826
1906.....	2,002,000	16.7	33,375,000	58.9	19,671,000	61	65	69	87½	769,717
1907.....	1,926,000	16.4	31,566,000	73.1	23,068,000	75	82	79	86	2,444,588
1908.....	1,948,000	16.4	31,851,000	73.6	23,455,000	75	77½	83	90	1,295,701
1909.....	2,006,000	16.1	32,239,000							
1909.....	<i>2,190,000</i>	<i>13.4</i>	<i>29,520,000</i>	71.8	21,163,000	72	80	74	80	242,262
1910 <sup>1</sup> .....	2,185,000	16.0	34,897,000	71.5	24,953,000	80	82	90	113	40,123
1911.....	2,127,000	15.6	33,119,000	83.2	27,557,000	91	94	90	95½	31,384
1912.....	2,117,000	16.8	35,684,000	66.3	23,636,000	58	64	60	64	1,854,738
1913.....	2,557,000	16.2	41,381,000	63.4	26,220,000	61	65	62	67	2,272,492
1914.....	2,541,000	16.8	42,779,000	86.5	37,018,000	107½	112½	115	122	13,026,778
1915.....	3,129,000	17.3	54,050,000	83.4	45,083,000	94½	98½	96½	99½	15,250,151
1916.....	3,213,000	15.2	48,862,000	122.1	59,676,000	130	151	200	240	13,703,499
1917.....	4,317,000	14.6	62,933,000	166.0	104,447,000	176	184	180	260	17,186,417
1918.....	6,391,000	14.2	91,041,000	151.6	138,038,000	154	164	145½	173	36,468,650
1919.....	7,063,000	12.5	88,478,000	134.5	119,041,000	149	182			

<sup>1</sup> Figures adjusted to census basis.

## RYE—Continued.

TABLE 59.—Rye: Revised acreage, production, and farm value, 1879 and 1889–1909.

[See head note of Table 4.]

Year.	Acreage.	Average yield per acre.	Production.	Average farm price per bushel Dec. 1.	Farm value Dec. 1.
	<i>Acres.</i>	<i>Bushels.</i>	<i>Bushels.</i>	<i>Cents.</i>	<i>Dollars.</i>
1879.....	1,842,000	13.7	25,201,000	67.6	17,040,000
1889.....	2,172,000	13.1	28,378,000	42.3	11,991,000
1890.....	2,184,000	12.1	26,414,000	62.6	16,536,000
1891.....	2,234,000	14.7	32,761,000	77.1	25,264,000
1892.....	2,251,000	13.0	29,253,000	53.6	15,674,000
1893.....	2,178,000	13.1	28,592,000	50.2	14,360,000
1894.....	2,164,000	13.7	29,613,000	49.4	14,622,000
1895.....	2,153,000	14.5	31,139,000	42.2	13,151,000
1896.....	2,126,000	13.6	28,913,000	38.8	11,231,000
1897.....	2,077,000	16.1	33,433,000	43.2	14,454,000
1898.....	2,071,000	15.9	32,888,000	44.5	14,640,000
1899.....	2,054,000	14.8	30,334,000	49.6	15,046,000
1900.....	2,042,000	15.1	30,791,000	49.8	15,341,000
1901.....	2,033,000	15.3	31,103,000	55.4	17,220,000
1902.....	2,051,000	17.2	35,255,000	50.5	17,798,000
1903.....	2,074,000	15.4	31,990,000	54.0	17,272,000
1904.....	2,085,000	15.3	31,805,000	68.9	21,923,000
1905.....	2,141,000	16.4	35,167,000	60.4	21,241,000
1906.....	2,186,000	16.7	36,559,000	58.5	21,381,000
1907.....	2,167,000	16.4	35,455,000	72.5	25,709,000
1908.....	2,175,000	16.4	35,768,000	72.8	26,023,000
1909.....	2,196,000	16.1	35,406,000	72.2	25,548,000

TABLE 60.—Rye: Acreage (sown and harvested), production, and total farm value, by States, 1919.

[000 omitted.]

State.	Acreage.		Production.	Farm value Dec. 1.	State.	Acreage.		Production.	Farm value Dec. 1.
	Sown in fall of 1918.	Harvested.				Sown in fall of 1918.	Harvested.		
	<i>Acres.</i>	<i>Acres.</i>	<i>Bush.</i>	<i>Dolls.</i>		<i>Acres.</i>	<i>Acres.</i>	<i>Bush.</i>	<i>Dolls.</i>
Vermont.....	1	1	17	26	Missouri.....	60	60	720	1,080
Massachusetts...	5	5	115	201	North Dakota....	2,068	1,945	15,560	18,828
Connecticut.....	12	11	220	440	South Dakota....	505	500	6,500	8,125
New York.....	126	120	1,932	2,898	Nebraska.....	410	408	6,650	7,648
New Jersey.....	84	81	1,296	2,074	Kansas.....	202	200	2,520	3,553
Pennsylvania...	230	228	3,648	5,727	Kentucky.....	63	62	744	1,302
Delaware.....	1	2	26	42	Tennessee.....	32	31	279	558
Maryland.....	31	30	420	685	Alabama.....	4	4	38	99
Virginia.....	73	72	828	1,408	Texas.....	7	7	119	199
West Virginia...	21	20	260	429	Oklahoma.....	26	25	350	525
North Carolina..	92	90	810	1,701	Arkansas.....	3	3	28	56
South Carolina..	18	17	170	502	Montana.....	75	68	272	503
Georgia.....	35	33	294	800	Wyoming.....	30	28	252	454
Ohio.....	116	115	1,886	2,735	Colorado.....	120	143	1,258	1,635
Indiana.....	384	380	5,320	7,448	Utah.....	19	18	126	252
Illinois.....	250	250	4,125	5,362	Idaho.....	9	9	135	236
Michigan.....	910	900	13,500	17,280	Washington.....	20	20	240	444
Wisconsin.....	525	525	8,295	11,032	Oregon.....	60	60	582	1,106
Minnesota.....	535	522	7,830	10,179	United States..	7,232	7,063	88,478	119,041
Iowa.....	70	70	1,113	1,469					



RYE—Continued.

TABLE 61.—Rye: Acreage sown and harvested, United States, 1906–1919.

Year.	Acreage sown in preceding fall.	Acreage harvested.	Year.	Acreage sown in preceding fall.	Acreage harvested.
	<i>Acres.</i>	<i>Acres.</i>		<i>Acres.</i>	<i>Acres.</i>
1906.....	2,100,000	2,002,000	1914.....	2,773,000	2,541,000
1907.....	2,061,000	1,926,000	1915.....	3,153,000	3,129,000
1908.....	2,015,000	1,948,000	1916.....	3,474,000	3,213,000
1909.....	2,326,000	2,196,000	1917.....	4,480,000	4,317,000
1910.....	2,413,000	2,185,000	1918.....	6,708,000	6,185,000
1911.....	2,415,000	2,127,000	1919.....	7,232,000	7,063,000
1912.....	2,478,000	2,117,000	1920.....	5,530,000	.....
1913.....	2,731,000	2,557,000			

TABLE 62.—Rye: Condition of crop, United States, on first of months named, 1899–1919.

Year.	De- cem- ber of pre- vious year.	April.	May.	June.	When har- vested.	Year.	De- cem- ber of pre- vious year.	April.	May.	June.	When har- vested.
	<i>P. ct.</i>	<i>P. ct.</i>	<i>P. ct.</i>	<i>P. ct.</i>	<i>P. ct.</i>		<i>P. ct.</i>	<i>P. ct.</i>	<i>P. ct.</i>	<i>P. ct.</i>	<i>P. ct.</i>
1899.....	98.9	84.9	85.2	84.5	85.6	1910.....	94.1	92.3	91.3	90.6	87.5
1900.....	98.2	84.8	88.5	87.6	80.4	1911.....	92.6	89.3	90.0	88.6	85.0
1901.....	99.1	93.1	94.6	93.9	93.0	1912.....	93.3	87.9	87.5	97.7	88.2
1902.....	89.9	85.4	83.4	88.1	90.2	1913.....	93.5	89.3	91.0	90.9	88.6
1903.....	98.1	97.9	93.3	90.6	89.5	1914.....	95.3	91.3	93.4	93.6	92.9
1904.....	92.7	82.3	81.2	86.3	88.9	1915.....	93.6	89.5	93.3	92.0	92.0
1905.....	90.5	92.1	93.5	94.0	93.2	1916.....	91.5	87.8	88.7	86.9	87.0
1906.....	95.4	90.9	92.9	89.9	91.3	1917.....	88.8	86.0	88.8	84.3	79.4
1907.....	96.2	92.0	88.0	88.1	89.7	1918.....	84.1	85.8	85.8	83.6	80.8
1908.....	91.4	89.1	90.3	91.3	91.2	1919.....	89.0	90.6	95.3	93.5	85.7
1909.....	87.6	87.2	88.1	89.6	91.4	1920.....	89.8	.....	.....	.....	.....

## RYE—Continued.

TABLE 63.—Rye: Yield per acre, price per bushel Dec. 1, and value per acre, by States.

State.	Yield per acre (bushels).											Farm price per bushel (cents).					Value per acre (dollars). <sup>1</sup>		
	10-year aver- age, 1910-1919.	1910	1911	1912	1913	1914	1915	1916	1917	1918	1919	10-year aver- age, 1910-1919.	1915	1916	1917	1918	1919	5-year aver- age, 1914-1918.	1919
	Vt.....	19.3	17.5	22.5	20.0	18.0	20.0	17.0	20.0	20.0	21.0	17.0	114	85	120	175	166	150	24.86
Mass.....	19.0	17.0	16.0	18.5	18.5	19.0	20.0	18.5	19.0	20.0	23.0	132	102	127	200	227	175	29.30	40.25
Conn.....	19.8	20.0	18.5	17.5	19.3	19.0	21.5	19.6	20.5	22.0	20.0	130	102	125	210	205	200	30.64	40.00
N. Y.....	17.5	18.3	16.7	16.5	17.2	17.7	18.7	18.0	19.0	16.5	16.1	113	93	128	184	172	150	23.90	24.15
N. J.....	18.0	18.0	16.4	17.5	18.0	18.5	20.0	19.0	18.5	18.5	16.0	112	92	117	175	173	160	24.04	25.60
Pa.....	17.0	17.0	15.1	17.5	17.5	18.0	18.0	17.0	17.0	17.0	16.0	107	84	109	170	165	157	21.11	25.12
Del.....	15.0	15.5	15.0	14.0	14.0	17.5	15.5	15.0	16.0	14.5	13.0	115	99	123	178	171	160	20.63	20.80
Md.....	15.4	16.1	14.5	15.5	14.4	17.0	16.5	15.5	16.0	15.0	14.0	110	88	110	168	170	163	19.71	22.82
Va.....	12.8	13.5	11.5	12.5	12.3	13.0	14.5	12.5	15.0	12.0	11.5	114	93	107	175	175	170	17.16	19.55
W. Va.....	13.5	12.9	11.0	13.0	13.5	14.5	14.0	16.0	13.5	13.7	13.0	117	93	119	169	180	165	18.52	21.45
N. C.....	9.9	10.0	10.0	9.3	10.3	10.0	11.5	9.7	10.0	9.0	9.0	135	105	130	200	198	210	14.60	18.90
S. C.....	10.2	10.0	10.0	9.5	10.5	11.5	10.0	9.8	10.0	11.2	10.0	195	151	185	285	295	295	22.40	29.50
Ga.....	9.3	10.4	9.5	9.2	9.5	9.3	9.2	9.5	8.3	8.8	8.9	176	140	160	270	210	272	16.58	24.21
Ohio.....	16.4	16.5	15.5	15.5	16.5	17.0	17.5	14.5	18.0	17.0	16.4	104	83	120	161	150	145	20.03	23.78
Ind.....	15.1	15.8	13.7	14.5	15.2	16.3	16.0	14.0	15.0	16.5	14.0	102	82	119	160	152	140	18.54	19.60
Ill.....	17.0	17.4	16.8	16.0	16.5	16.0	18.5	15.5	17.5	19.0	16.5	102	83	122	165	150	130	21.05	21.45
Mich.....	14.7	15.3	14.6	13.3	14.3	16.0	15.5	14.3	14.0	14.3	15.0	103	85	130	165	150	128	18.18	19.20
Wis.....	17.2	16.0	17.0	18.3	17.5	16.5	18.5	16.2	18.5	17.6	15.8	104	87	132	169	150	133	22.03	21.01
Minn.....	18.4	17.0	18.7	23.0	19.0	18.8	19.5	15.0	18.5	20.0	15.0	98	81	127	167	150	130	22.50	19.50
Iowa.....	18.1	18.5	18.0	19.0	18.2	19.0	18.5	17.0	18.0	19.0	15.9	97	80	115	155	147	132	20.96	20.99
Mo.....	13.8	15.0	14.1	14.8	15.0	14.0	13.5	11.0	14.7	14.0	12.0	109	86	123	165	163	150	16.88	18.00
N. Dak.....	13.1	8.5	16.6	18.0	14.4	17.1	15.0	13.3	9.5	10.5	8.0	95	79	125	164	145	121	14.73	9.68
S. Dak.....	16.1	17.0	10.0	19.5	13.2	17.0	19.5	18.0	16.0	18.0	13.0	93	76	118	155	141	125	19.90	16.25
Nebr.....	15.4	16.0	13.0	16.0	14.5	16.0	17.5	16.0	15.6	12.9	16.3	92	73	116	155	135	115	16.96	18.74
Kans.....	14.6	14.0	11.0	15.9	14.0	20.0	16.0	14.5	14.0	14.3	12.6	104	76	110	167	170	141	18.36	17.77
Ky.....	12.5	13.0	12.0	13.0	12.4	13.7	12.0	11.2	12.5	13.6	12.0	118	94	129	175	161	175	16.51	21.00
Tenn.....	10.9	11.0	11.9	11.5	12.0	13.0	10.5	10.0	9.8	10.0	9.0	131	103	135	195	192	200	15.07	18.00
Ala.....	11.0	12.0	10.0	11.5	11.0	13.0	10.0	13.0	9.5	11.0	9.5	173	135	175	268	261	260	20.94	24.70
Tex.....	12.7	11.5	10.0	16.6	15.0	14.8	17.0	10.0	10.0	5.4	17.0	134	103	120	196	235	167	15.29	28.39
Okla.....	11.9	13.7	9.5	12.0	9.5	16.0	13.5	10.0	10.0	11.0	14.0	116	77	125	170	187	150	15.13	21.00
Ark.....	10.8	12.0	10.0	10.5	11.5	10.5	10.5	10.0	13.5	10.5	9.5	127	100	115	150	210	200	15.06	19.00
Mont.....	18.0	20.0	23.0	23.5	21.0	21.0	22.5	20.5	12.7	12.0	4.0	98	65	96	165	144	185	17.45	7.40
Wyo.....	17.0	18.5	20.0	19.0	19.0	17.0	20.0	15.5	14.0	18.0	9.0	107	90	108	155	152	180	19.51	16.20
Colo.....	14.3	14.0	12.0	19.5	17.0	17.5	17.5	14.0	16.0	7.0	8.8	91	70	105	146	140	130	14.30	11.44
Utah.....	13.9	18.5	15.5	15.0	17.0	17.5	15.5	12.0	8.0	13.0	7.0	103	65	100	160	180	200	13.76	14.00
Idaho.....	18.9	20.0	22.5	22.0	22.0	20.0	20.0	17.0	15.5	15.0	15.0	96	68	95	135	165	175	17.76	26.25
Wash.....	17.1	20.5	22.0	20.0	21.0	19.7	18.2	14.5	12.7	10.0	12.0	112	75	111	175	200	185	17.74	22.20
Oreg.....	15.2	15.1	19.5	16.0	17.5	16.0	18.0	17.0	12.7	11.0	9.7	120	90	115	170	205	190	19.18	18.43
U. S.....	15.5	16.0	15.6	16.8	16.2	16.8	17.3	15.2	14.6	14.2	12.5	102.8	83.4	122.1	166.0	151.0	134.5	18.67	16.85

<sup>1</sup> Based upon farm price Dec. 1.

RYE—Continued.

TABLE 64.—Rye: Farm price, cents per bushel on first of each month, 1910-1919.

Date.	1919	1918	1917	1916	1915	1914	1913	1912	1911	1910	Average.
Jan. 1	150.7	170.3	118.5	85.3	90.2	62.5	63.8	82.7	73.3	74.8	97.2
Feb. 1	140.4	174.8	123.5	88.3	100.6	61.7	68.9	84.4	73.1	76.1	99.2
Mar. 1	132.2	201.0	126.0	85.6	105.4	61.9	63.2	84.0	71.9	76.5	100.8
Apr. 1	145.8	235.1	135.6	83.6	100.4	63.0	62.9	85.1	75.4	76.6	106.4
May 1	155.5	221.1	164.1	83.7	101.9	62.9	62.4	84.6	75.8	74.9	108.7
June 1	143.7	187.6	183.0	83.8	98.1	64.4	64.1	86.1	77.9	74.8	106.4
July 1	138.6	169.9	177.1	83.3	93.7	63.1	63.2	83.6	76.9	74.6	102.4
Aug. 1	149.7	163.9	178.1	83.4	89.0	61.0	60.7	77.9	75.5	74.4	101.4
Sept. 1	138.3	159.3	161.9	99.7	85.5	75.4	63.0	70.8	76.9	74.1	100.5
Oct. 1	135.8	154.0	169.8	104.1	81.7	79.0	64.8	70.1	79.7	72.8	101.2
Nov. 1	129.8	152.6	168.8	115.3	85.7	80.1	63.2	68.8	83.1	71.6	101.9
Dec. 1	134.5	151.6	166.0	122.1	83.4	86.5	63.4	66.3	83.2	71.5	102.8
Average	138.7	167.4	156.5	99.7	89.2	72.8	63.8	74.9	78.1	73.7	101.5

TABLE 65.—Rye: Wholesale price per bushel, 1913-1919.

Date.	Philadelphia.			Cincinnati.			Chicago.			Duluth.			San Francisco.		
	No. 2 Western.			No. 2.			No. 2.			No grade.			Per 100 lbs.		
	Low.	High.	Average.	Low.	High.	Average.	Low.	High.	Average.	Low.	High.	Average.	Low.	High.	Average.
1913.	Cts.	Cts.	Cts.	Cts.	Cts.	Cts.	Cts.	Cts.	Cts.	Cts.	Cts.	Cts.	Cts.	Cts.	Cts.
January-June	65	70	.....	60	70	65.8	58	65½	62.5	52	59	55.6	132½	147½	140.0
July-December	65	77	.....	60	72	65.3	61	70½	64.9	50	65	56.4	135	165	145.0
1914.															
January-June	65	75	.....	62	71	65.7	58	67	62.8	50	62	56.3	152½	165	159.1
July-December	65	125	109.4	60	115	92.6	55	112½	89.2	57	107	86.6	130	165	154.2
1915.															
January-June	105	130	117.0	107	133	115.9	111½	131	118.9	106	128	114.2	160	225	186.6
July-December	90	112	.....	92	112	102.1	91	119	100.3	87	111	94.4	145	165	156.5
1916.															
January-June	90	118	.....	90	106	98.9	90	104¾	97.8	87	98	93.4	150	160	155.4
July-December	90	155	138.3	96	155	127.3	94	153	125.5	89	150	123.0	152½	265	197.6
1917.															
January-June	140	245	186.9	140	240	180.1	138	245	184.9	134	240	177.7	230	400	279.6
July-December	173	245	200.6	170	230	191.4	165	243	189.1	168	298	187.8	290	400	339.0
1918.															
January-June	175	188	180.4	175	280	218.9	160	295	228.6	182	300	246.5	390	425	409.7
July-December	105	176½	172.5	155	170	160.7	154	185	164.5	150	186	165.6	.....	.....	.....
1919.															
January	176½	176½	176.5	143	162	154.9	157	165	162.8	156	156	156.0	.....	( <sup>2</sup> )	.....
February	.....	( <sup>1</sup> )	.....	123	140	129.9	124	151	136.7	128½	141¾	133.8	.....	( <sup>2</sup> )	.....
March	.....	( <sup>1</sup> )	.....	142	171	154.3	145	176½	157.1	141½	170¾	154.3	.....	( <sup>2</sup> )	.....
April	176	176	176.0	167	172	169.2	164¾	181¼	173.5	163¾	178½	170.9	.....	( <sup>2</sup> )	.....
May	160	176	164.7	145	173	159.9	145½	173	156.3	140½	171	146.7	.....	( <sup>2</sup> )	.....
June	148	160	159.5	146	150	148.8	138¾	153½	148.2	135½	154½	147.6	.....	.....	.....
January-June	148	176½	169.2	123	173	152.8	124	181½	155.7	128½	178½	151.6	.....	( <sup>2</sup> )	.....
July	148	158	150.4	140	168	152.9	141	169	158.6	135¼	166½	154.8	350	375	362.5
August	155	165	155.3	156	163	158.9	144½	164½	153.7	138	157½	150.3	350	375	362.5
September	115	155	131.2	142	153	147.0	135	145	142.0	134	143½	140.5	350	375	360.3
October	.....	( <sup>1</sup> )	( <sup>1</sup> )	141	148	144.7	135	143¾	139.4	133½	142¾	136.7	330	350	347.3
November	.....	( <sup>1</sup> )	( <sup>1</sup> )	136	146	140.0	133½	150½	140.1	134	149½	139.8	310	337½	325.6
December	( <sup>1</sup> )	( <sup>1</sup> )	( <sup>1</sup> )	146	177	161.1	149	182	167.4	150½	178¾	166.8	310	325	317.5
July-December	115	165	146.0	136	177	150.8	133½	182	150.2	133¼	178¾	148.2	310	375	346.0

<sup>1</sup> No quotations.

<sup>2</sup> Nominal.

## RYE—Continued.

TABLE 66.—*Rye (including flour): International trade, calendar years 1911–1913, 1917, and 1918.*

[See "General note," Table 12.]

## EXPORTS.

[000 omitted.]

Country.	Average 1911–1913.	1917 (prelim.).	1918 (prelim.).	Country.	Average 1911–1913.	1917 (prelim.).	1918 (prelim.).
<i>From—</i>	<i>Bushels.</i>	<i>Bushels.</i>	<i>Bushels.</i>		<i>Bushels.</i>	<i>Bushels.</i>	<i>Bushels.</i>
Argentina.....	443	( <sup>1</sup> )	2	Rumania.....	3,411		
Belgium.....	914			Russia.....	34,921		
Bulgaria.....	2,336			United States.....	855	14,689	16,308
Canada.....	69	833	798	Other countries.....	514		
Denmark.....	303	555	582				
Germany.....	44,951			Total.....	107,587		
Netherlands.....	18,870						

## IMPORTS.

<i>Into—</i>							
Austria-Hungary...	1,224			Norway.....	10,520	5,095	
Belgium.....	6,157			Russia.....	5,231		
Denmark.....	8,587	443	41	Sweden.....	3,769	461	
Finland.....	15,472			Switzerland.....	729	198	452
France.....	4,138	21	1,346	United Kingdom...	2,195	5,353	5,300
Germany.....	16,900			Other countries.....	677		
Italy.....	721	1,440	3,506				
Netherlands.....	31,023			Total.....	107,343		

<sup>1</sup> Less than 500 bushels.

## BUCKWHEAT.

TABLE 67.—*Buckwheat: Acreage, production, and value in the United States, 1849–1919.*

NOTE.—Figures in *italics* are census returns; figures in roman are estimates of the Department of Agriculture. Estimates of acres are obtained by applying estimated percentages of increase or decrease to the published numbers of the preceding year, except that a revised base is used for applying percentage estimates whenever new census data are available.

Year.	Acreage (thousands of acres).	Average yield per acre (bushels).	Production (thousands of bushels).	Average farm price Dec. 1 (cents per bushel).	Farm value Dec. 1 (thousands of dollars).	Year.	Acreage (thousands of acres).	Average yield per acre (bushels).	Production (thousands of bushels).	Average farm price Dec. 1 (cents per bushel).	Farm value Dec. 1 (thousands of dollars).
1849.....			8,957			1890.....	845	14.7	12,433	57.2	7,110
1859.....			17,572			1891.....	849	15.0	12,761	57.0	7,272
1866.....	1,046	21.8	22,792	67.6	15,413	1892.....	861	14.1	12,143	51.8	6,296
1867.....	1,228	17.4	21,359	78.7	16,812	1893.....	816	14.9	12,132	58.3	7,074
1868.....	1,114	17.8	19,864	78.0	15,490	1894.....	789	16.1	12,668	55.6	7,040
1869.....	1,029	16.9	17,431	71.9	12,535	1895.....	763	20.1	15,341	45.2	6,936
1869.....			9,822			1896.....	755	18.7	14,090	39.2	5,522
1870.....	537	18.3	9,842	70.5	6,937	1897.....	718	20.9	14,997	42.1	6,319
1871.....	414	20.1	8,329	74.5	6,208	1898.....	678	17.3	11,722	45.0	5,271
1872.....	448	18.1	8,134	73.5	5,979	1899.....	670	16.6	11,094	55.7	6,184
1873.....	454	17.3	7,838	75.0	5,879	1899.....	807	13.9	11,234		
1874.....	453	17.7	8,017	72.9	5,844	1900.....	638	15.0	9,567	55.8	5,341
1875.....	576	17.5	10,082	62.0	6,255	1901.....	811	18.6	15,126	56.3	8,523
1876.....	666	14.5	9,669	66.6	6,436	1902.....	805	18.1	14,530	59.6	8,655
1877.....	650	15.7	10,177	66.9	6,808	1903.....	804	17.7	14,244	60.7	8,651
1878.....	673	18.2	12,247	52.6	6,441	1904.....	794	18.9	15,008	62.2	9,331
1879.....	640	20.5	13,140	59.8	7,856	1905.....	760	19.2	14,585	58.7	8,565
1879.....	848	13.9	11,817			1906.....	789	18.6	14,642	59.6	8,727
1880.....	823	17.8	14,618	59.4	8,682	1907.....	800	17.9	14,290	69.8	9,975
1881.....	829	11.4	9,486	86.5	8,206	1908.....	803	19.8	15,874	75.6	12,004
1882.....	847	13.0	11,019	73.0	8,039	1909.....	834	20.9	17,438		
1883.....	857	8.9	7,669	82.2	6,304	1909.....	878	16.9	14,849	70.1	10,346
1884.....	879	12.6	11,116	58.9	6,549	1910 <sup>1</sup> .....	860	20.5	17,598	66.1	11,636
1885.....	914	13.8	12,626	55.9	7,057	1911.....	833	21.1	17,549	72.6	12,735
1886.....	918	12.9	11,869	54.5	6,465	1912.....	841	22.9	19,249	66.1	12,720
1887.....	911	11.9	10,844	56.5	6,122	1913.....	805	17.2	13,833	75.5	10,445
1888.....	913	13.2	12,050	63.3	7,628	1914.....	792	21.3	16,881	76.4	12,892
1889.....	837	14.5	12,110	50.5	6,113	1915.....	769	19.6	15,056	78.7	11,843
1889.....	837	14.5	12,110			1916.....	828	14.1	11,662	112.7	13,147
						1917.....	924	17.3	16,022	160.0	25,631
						1918.....	1,027	16.5	16,905	166.5	28,142
						1919.....	790	20.6	16,301	147.4	24,026

<sup>1</sup> Figures adjusted to census basis.

BUCKWHEAT—Continued.

TABLE 68.—Buckwheat: Revised acreage, production, and farm value, 1879 and 1889–1909.

[See head note of Table 4.]

Year.	Acreage.	Average yield per acre.	Production.	Average farm price per bushel Dec. 1.	Farm value Dec. 1.
	<i>Acres.</i>	<i>Bushels.</i>	<i>Bushels.</i>	<i>Cents.</i>	<i>Dollars.</i>
1879.....	848,000	20.7	17,530,000	60.3	10,575,000
1889.....	837,000	14.5	12,109,000	50.5	6,115,000
1890.....	863,000	14.7	12,678,000	57.3	7,264,000
1891.....	867,000	15.0	13,013,000	57.0	7,422,000
1892.....	899,000	14.1	12,643,000	52.0	6,573,000
1893.....	873,000	14.7	12,866,000	58.3	7,503,000
1894.....	864,000	15.9	13,721,000	55.7	7,638,000
1895.....	842,000	19.9	16,748,000	45.3	7,583,000
1896.....	853,000	18.5	15,805,000	39.3	6,211,000
1897.....	838,000	20.6	17,260,000	42.1	7,259,000
1898.....	811,000	17.2	13,961,000	45.0	6,278,000
1899.....	807,000	16.1	13,001,000	55.9	7,263,000
1900.....	795,000	14.9	11,810,000	55.8	6,588,000
1901.....	852,000	18.4	15,693,000	56.4	8,857,000
1902.....	856,000	17.9	15,286,000	59.6	9,110,000
1903.....	870,000	17.5	15,248,000	60.8	9,277,000
1904.....	876,000	18.6	16,327,000	62.5	10,208,000
1905.....	840,000	18.8	15,797,000	58.6	9,261,000
1906.....	865,000	18.2	15,734,000	59.7	9,386,000
1907.....	838,000	17.7	14,858,000	70.0	10,397,000
1908.....	853,000	19.4	16,541,000	75.7	12,518,000
1909.....	878,000	20.5	17,983,000	70.2	12,628,000

TABLE 69.—Buckwheat: Acreage, production, and total farm value, by States, 1919.

[000 omitted.]

State.	Acreage.	Production.	Farm value Dec. 1.	State.	Acreage.	Production.	Farm value Dec. 1.
	<i>Acres.</i>	<i>Bushels.</i>	<i>Dollars.</i>		<i>Acres.</i>	<i>Bushels.</i>	<i>Dollars.</i>
Maine.....	17	408	714	Ohio.....	26	621	963
New Hampshire.....	2	52	81	Indiana.....	14	231	346
Vermont.....	9	225	382	Illinois.....	4	72	130
Massachusetts.....	2	44	70	Michigan.....	48	662	907
Connecticut.....	5	100	200	Wisconsin.....	31	502	753
New York.....	233	5,126	7,433	Minnesota.....	15	240	312
New Jersey.....	11	198	297	Iowa.....	7	98	166
Pennsylvania.....	256	5,530	7,742	Missouri.....	6	90	166
Delaware.....	6	108	173	Nebraska.....	1	16	29
Maryland.....	14	322	499	Tennessee.....	5	90	135
Virginia.....	25	475	736				
West Virginia.....	42	882	1,499	United States..	790	16,301	24,026
North Carolina.....	11	209	293				

TABLE 70.—Buckwheat: Condition of crop, United States, on first of months named, 1899–1919.

Year.	Aug.	Sept.	When harvested.	Year.	Aug.	Sept.	When harvested.	Year.	Aug.	Sept.	When harvested.
	<i>P. ct.</i>	<i>P. ct.</i>	<i>P. ct.</i>		<i>P. ct.</i>	<i>P. ct.</i>	<i>P. ct.</i>		<i>P. ct.</i>	<i>P. ct.</i>	<i>P. ct.</i>
1899.....	93.2	75.2	70.2	1906.....	93.2	91.2	84.9	1913.....	85.5	75.4	65.9
1900.....	87.9	80.5	72.8	1907.....	91.9	77.4	80.1	1914.....	88.8	87.1	83.3
1901.....	91.1	90.9	90.5	1908.....	89.4	87.8	81.6	1915.....	92.6	88.6	81.9
1902.....	91.4	86.4	80.5	1909.....	86.4	81.0	79.5	1916.....	87.8	78.5	66.9
1903.....	93.9	91.0	83.0	1910.....	87.9	82.3	81.7	1917.....	92.2	90.2	74.8
1904.....	92.8	91.5	88.7	1911.....	82.9	83.8	81.4	1918.....	88.6	83.3	75.6
1905.....	92.6	91.3	91.6	1912.....	88.4	91.6	89.2	1919.....	88.1	90.1	88.0

## BUCKWHEAT—Continued.

TABLE 71.—Buckwheat: Yield per acre, price per bushel Dec. 1, and value per acre, by States.

State.	Yield per acre (bushels).											Farm price per bushel (cents).					Value per acre (dollars.) <sup>1</sup>		
	10-year average, 1910-1919.	1910	1911	1912	1913	1914	1915	1916	1917	1918	1919	10-year average, 1910-1919.	1915	1916	1917	1918	1919	5-year average, 1914-1918.	1919
Me.....	26.8	32.5	30.0	29.4	32.0	29.0	26.0	24.0	21.5	20.0	24.0	96	70	95	150	150	175	24.13	42.00
N. H.....	25.4	31.0	27.3	31.0	31.0	25.0	30.0	20.0	16.0	17.0	26.0	107	81	100	183	200	156	25.02	40.56
Vt.....	24.2	24.0	24.3	30.0	25.0	28.0	27.0	17.5	20.0	21.0	25.0	106	82	105	150	160	170	25.42	42.50
Mass.....	18.4	22.0	21.0	21.0	17.0	18.5	16.0	16.0	15.0	16.0	22.0	118	95	140	166	196	160	21.88	35.20
Conn.....	19.0	19.5	19.0	20.5	17.0	18.5	20.0	19.0	17.3	19.0	20.0	128	96	120	200	210	200	26.82	40.00
N. Y.....	19.1	23.0	21.3	23.8	14.3	23.0	19.0	12.0	18.0	15.0	22.0	104	80	122	160	175	145	20.47	31.90
N. J.....	20.0	21.5	20.0	22.0	22.0	21.0	21.0	19.0	18.0	18.0	18.0	104	83	108	158	170	150	22.88	27.00
Pa.....	19.7	19.5	21.9	24.2	18.5	20.5	21.0	14.0	18.0	18.0	21.6	100	78	111	163	160	140	21.13	30.24
Del.....	18.8	20.5	19.0	16.0	17.0	19.0	18.5	19.0	20.0	20.5	18.0	98	75	118	148	143	160	21.93	28.80
Md.....	19.4	18.5	20.0	17.5	16.5	18.5	20.0	19.0	21.0	20.0	23.0	103	72	110	165	165	155	23.59	35.65
Va.....	19.8	18.0	16.0	21.5	23.1	19.4	20.0	19.2	21.1	21.0	19.0	103	80	95	150	163	155	23.28	29.45
W. Va.....	21.4	23.0	24.0	24.0	21.0	21.5	22.0	18.3	20.0	19.5	21.0	109	80	101	170	173	170	24.33	35.70
N. C.....	18.8	19.0	19.0	17.5	19.3	19.0	17.5	17.5	20.0	20.0	19.0	99	82	85	130	150	140	20.20	26.60
Ohio.....	19.8	18.0	21.0	19.5	18.0	24.0	23.0	17.7	17.2	16.0	23.9	103	77	110	153	156	155	21.34	37.04
Ind.....	17.0	17.7	18.3	19.0	18.5	17.5	14.0	18.0	15.0	15.0	16.5	103	80	112	155	160	150	18.45	24.75
Ill.....	18.4	20.0	18.1	22.0	17.0	17.7	17.0	17.0	19.0	17.8	18.0	119	90	130	170	180	180	23.71	32.40
Mich.....	14.2	15.3	18.0	17.0	15.0	18.5	14.5	11.0	9.0	10.0	13.8	98	72	115	147	170	137	13.29	18.91
Wis.....	15.4	14.0	17.5	17.0	16.5	17.5	13.0	14.0	12.2	15.9	16.2	105	83	116	174	165	150	17.56	24.30
Minn.....	16.8	16.0	18.0	21.0	16.5	17.0	17.5	15.0	14.0	17.0	16.0	97	75	112	135	170	130	17.92	20.80
Iowa.....	15.3	14.9	17.5	19.0	14.0	18.3	13.0	15.0	12.9	15.0	14.0	116	80	125	200	180	169	18.85	23.66
Mo.....	14.0	16.5	10.0	15.0	11.0	15.5	15.0	14.0	15.0	13.0	15.0	120	90	133	144	180	184	18.31	27.60
Nobr.....	17.6	20.0	16.0	18.0	20.0	18.5	20.0	17.0	16.0	14.0	16.0	114	95	110	150	165	180	20.07	28.80
Tenn.....	17.5	15.0	16.0	18.0	15.0	22.3	18.0	18.0	17.0	18.0	18.0	101	76	100	150	140	150	19.95	27.00
U. S....	19.1	20.5	21.1	22.9	17.2	21.3	19.6	14.1	17.3	16.5	20.6	102.2	78.7	112.7	160.0	166.5	147.4	20.54	30.41

<sup>1</sup> Based upon farm price Dec. 1.

TABLE 72.—Buckwheat: Farm price, cents per bushel on first of each month, 1910-1919.

	1919	1918	1917	1916	1915	1914	1913	1912	1911	1910	Average.
Jan. 1.....	162.9	162.7	117.2	81.5	77.9	76.6	66.8	73.7	65.8	70.0	95.5
Feb. 1.....	158.1	161.9	114.6	80.7	83.7	75.6	69.4	73.0	64.4	72.0	95.4
Mar. 1.....	148.4	168.2	124.8	83.2	85.5	75.1	67.0	76.9	64.1	70.6	96.4
Apr. 1.....	149.6	170.1	128.3	83.1	85.3	76.9	68.3	76.9	65.3	73.4	97.7
May 1.....	147.3	176.0	150.6	84.9	84.6	77.3	71.4	79.9	65.8	71.0	100.9
June 1.....	165.6	191.0	183.7	87.0	86.9	79.0	70.8	84.8	70.1	73.7	109.3
July 1.....	160.8	200.8	209.2	93.1	92.1	85.5	72.9	86.2	72.4	78.0	115.1
Aug. 1.....	165.9	192.7	189.3	89.0	89.2	81.2	72.4	83.6	76.0	74.8	111.4
Sept. 1.....	159.8	190.3	164.3	86.4	81.4	79.8	70.0	76.6	74.0	72.6	105.5
Oct. 1.....	162.0	180.0	154.4	90.4	73.7	78.7	74.1	69.7	69.6	71.3	102.4
Nov. 1.....	151.0	173.0	154.2	102.9	78.5	78.0	75.5	65.5	73.0	65.9	101.8
Dec. 1.....	147.4	166.5	160.0	112.7	78.7	76.4	75.5	66.1	72.6	66.1	102.2
Average.....	154.9	174.7	153.2	94.7	81.0	77.9	72.4	72.6	70.3	69.8	102.2

FLAX.

TABLE 73.—Flax: Area and production in undermentioned countries, 1909–1918.  
[000 omitted.]

Country.	Area.				Production.							
					Seed.				Fiber.			
	Average 1909– 1913. <sup>1</sup>	1916	1917	1918	Average 1909– 1913. <sup>1</sup>	1916	1917	1918	Average 1909– 1913. <sup>1</sup>	1916	1917	1918
	Acres.	Acres.	Acres.	Acres.	Bush.	Bush.	Bush.	Bush.	Lbs.	Lbs.	Lbs.	Lbs.
NORTH AMERICA.												
United States.....	2,490	1,474	1,984	1,938	19,505	14,296	9,164	14,657	.....	.....	.....	.....
Canada:												
Quebec.....	1	1	6	7	11	5	47	83	.....	.....	.....	.....
Ontario.....	8	4	4	16	128	42	52	196	.....	.....	.....	.....
Manitoba.....	58	16	16	108	706	210	147	1,091	.....	.....	.....	.....
Saskatchewan.....	893	542	754	841	10,393	6,692	4,710	4,205	.....	.....	.....	.....
Alberta.....	76	95	140	96	830	1,311	979	480	.....	.....	.....	.....
Total Canada..	1,036	658	920	1,068	12,068	8,260	5,935	6,055	.....	.....	.....	.....
Mexico.....	(2)	(2)	(2)	(2)	150	(2)	(2)	(2)	.....	.....	.....	.....
Total.....	3,526	2,132	2,904	3,006	31,723	22,556	15,099	20,712	.....	.....	.....	.....
SOUTH AMERICA.												
Argentina.....	3,683	4,001	3,207	3,229	31,989	39,280	4,032	19,588	.....	.....	.....	.....
Uruguay.....	106	44	36	30	793	391	122	333	.....	.....	.....	.....
Total.....	3,789	4,045	3,243	3,259	32,782	39,680	4,154	19,921	.....	.....	.....	.....
EUROPE.												
Austria <sup>2</sup> .....	97	(2)	(2)	(2)	694	(2)	(2)	(2)	53,096	(2)	(2)	(2)
Hungary <sup>2</sup> .....	24	(2)	(2)	(2)	196	(2)	(2)	(2)	20,548	(2)	(2)	(2)
Croatia-Slavonia <sup>2</sup> .....	17	(2)	(2)	(2)	21	(2)	(2)	(2)	8,046	(2)	(2)	(2)
Bosnia-Herzegovina <sup>2</sup> .....	(2)	(2)	(2)	(2)	4	(2)	(2)	(2)	1,080	(2)	(2)	(2)
Belgium.....	50	(2)	(2)	(2)	443	(2)	(2)	(2)	46,487	(2)	(2)	(2)
Bulgaria <sup>2</sup> .....	1	(2)	(2)	(2)	7	(2)	(2)	(2)	524	(2)	(2)	(2)
France <sup>2,4</sup> .....	61	15	20	21	533	146	134	(2)	40,623	11,061	8,909	(2)
Ireland.....	53	91	108	143	(2)	(2)	(2)	(2)	23,701	32,461	34,410	(2)
Italy.....	22	21	20	46	320	362	323	472	6,289	5,512	5,291	5,291
Netherlands.....	33	30	30	14	374	367	222	145	17,276	21,844	11,756	6,559
Roumania <sup>2</sup> .....	52	20	(2)	5 185	503	(2)	(2)	5 292	4,864	(2)	(2)	4,455
Russia proper <sup>2</sup> .....	3,217	3,505	(2)	(2)	19,772	(2)	(2)	(2)	1,022	(2)	(2)	(2)
Poland <sup>2</sup> .....	88	(2)	(2)	(2)	874	(2)	(2)	(2)	42,450	(2)	(2)	(2)
Northern Caucasia <sup>2</sup> .....	104	(2)	(2)	(2)	679	(2)	(2)	(2)	26,130	(2)	(2)	(2)
Serbia <sup>2</sup> .....	4	(2)	(2)	(2)	(2)	(2)	(2)	(2)	1,812	(2)	(2)	(2)
Spain.....	(2)	3	4	4	(2)	(2)	22	65	(2)	(2)	(2)	6,768
Sweden <sup>2</sup> .....	4	(2)	(2)	5	15	(2)	(2)	(2)	1,208	333	(2)	(2)
Total.....	3,827	.....	.....	.....	24,435	.....	.....	.....	295,156	.....	.....	.....
ASIA.												
British India <sup>7</sup> .....	3,821	3,334	3,564	3,797	19,733	19,040	21,040	20,600	.....	.....	.....	.....
Japan.....	12	36	48	(2)	(2)	(2)	(2)	(2)	30,187	104,028	101,441	(2)
Russia:												
Central Asia (4 gov.).....	120	(2)	(2)	(2)	510	(2)	(2)	(2)	51,864	(2)	(2)	(2)
Siberia (4 gov.).....	147	(2)	(2)	(2)	852	(2)	(2)	(2)	38,109	(2)	(2)	(2)
Transcaucasia (1 gov.).....	18	(2)	(2)	(2)	94	(2)	(2)	(2)	6,429	(2)	(2)	(2)
Total.....	4,118	.....	.....	.....	21,189	.....	.....	.....	126,589	.....	.....	.....
AFRICA.												
Algeria.....	1	1	1	(2)	11	(2)	(2)	(2)	(2)	(2)	(2)	(2)
Grand total.....	15,261	.....	.....	.....	110,140	.....	.....	.....	421,745	.....	.....	.....

<sup>1</sup> Five year average except where statistics were not available.  
<sup>2</sup> No official statistics.  
<sup>3</sup> Old boundaries.  
<sup>4</sup> Excludes territory occupied by the enemy.  
<sup>5</sup> Including Bessarabia but excluding Dobrudja.  
<sup>6</sup> Includes hemp.  
<sup>7</sup> Includes certain native States.

## FLAX—Continued.

TABLE 74.—*Flax (seed and fiber): Total production of countries named in Table 73, 1896–1915.*

Year.	Production.		Year.	Production.	
	Seed.	Fiber.		Seed.	Fiber.
	<i>Bushels.</i>	<i>Pounds</i>		<i>Bushels.</i>	<i>Pounds.</i>
1896.....	82,684,000	1,714,205,000	1906.....	88,165,000	1,871,723,000
1897.....	57,596,000	1,498,054,000	1907.....	102,960,000	2,042,390,000
1898.....	72,938,000	1,780,693,000	1908.....	100,850,000	1,907,591,000
1899.....	66,348,000	1,138,763,000	1909.....	100,820,000	1,384,524,000
1900.....	62,432,000	1,315,931,000	1910.....	85,253,000	913,112,000
1901.....	72,314,000	1,050,260,000	1911.....	101,339,000	1,011,350,000
1902.....	83,891,000	1,564,840,000	1912.....	130,291,000	1,429,967,000
1903.....	110,455,000	1,492,383,000	1913.....	132,477,000	1,384,757,000
1904.....	107,743,000	1,517,922,000	1914.....	94,559,000	1,044,746,000
1905.....	100,458,000	1,494,229,000	1915.....	103,287,000	975,685,000

TABLE 75.—*Flaxseed: Acreage, production, value, and condition in the United States, 1849–1919.*

NOTE.—Figures in *italics* are census returns; figures in roman are estimates of the Department of Agriculture. Estimates of acres are obtained by applying estimated percentages of increase or decrease to the published numbers of the preceding year, except that a revised base is used for applying percentage estimates whenever new census data are available.

Year.	Acreage.	Average yield per acre.	Production.	Average farm price per bushel Dec. 1.	Farm value Dec. 1.	Condition of growing crop.			
						July 1.	Aug. 1.	Sept. 1.	When harvested.
	<i>Acres.</i>	<i>Bushels.</i>	<i>Bushels.</i>	<i>Cents.</i>	<i>Dollars.</i>	<i>P. ct.</i>	<i>P. ct.</i>	<i>P. ct.</i>	<i>P. ct.</i>
1849.....			562,000						
1859.....			567,000						
1869.....			1,730,000						
1879.....			7,171,000						
1889.....	1,319,000	7.8	10,250,000						
1899.....	2,111,000	9.5	19,979,000						
1902.....	3,740,000	7.8	29,285,000	105.2	30,815,000				
1903.....	3,233,000	8.4	27,301,000	81.7	22,292,000	86.2	80.3	80.5	74.0
1904.....	2,264,000	10.3	23,401,000	99.3	23,229,000	86.6	78.9	85.8	87.0
1905.....	2,535,000	11.2	28,478,000	84.4	24,049,000	92.7	96.7	94.2	91.5
1906.....	2,506,000	10.2	25,576,000	101.3	25,899,000	93.2	92.2	89.0	87.4
1907.....	2,864,000	9.0	25,851,000	95.6	24,713,000	91.2	91.9	85.4	78.0
1908.....	2,679,000	9.6	25,805,000	118.4	30,577,000	92.5	86.1	82.5	81.2
1909.....	2,742,000	9.4	25,856,000						
1909.....	2,083,000	9.4	19,513,000	153.0	29,796,000	95.1	92.7	88.9	84.9
1910 <sup>1</sup> .....	2,467,000	5.2	12,718,000	231.7	29,472,000	65.0	51.7	48.3	47.2
1911.....	2,757,000	7.0	19,370,000	182.1	35,272,000	80.9	71.0	68.4	69.6
1912.....	2,851,000	9.8	28,073,000	114.7	32,202,000	88.9	87.5	86.3	83.8
1913.....	2,291,000	7.8	17,853,000	119.9	21,399,000	82.0	77.4	74.9	74.7
1914.....	1,645,000	8.4	13,749,000	126.0	17,318,000	90.5	82.1	72.9	77.4
1915.....	1,387,000	10.1	14,030,000	174.0	24,410,000	88.5	91.2	87.6	84.5
1916.....	1,474,000	9.7	14,296,000	248.6	35,541,000	90.3	84.0	84.8	86.2
1917.....	1,984,000	4.6	9,164,000	296.6	27,182,000	84.0	60.6	50.2	51.3
1918.....	1,910,000	7.0	13,369,000	340.1	45,470,000	79.8	70.6	72.6	70.8
1919.....	1,683,000	5.3	8,919,000	438.9	39,145,000	73.5	52.7	50.5	52.6

<sup>1</sup> Figures adjusted to census basis.



FLAX—Continued.

TABLE 76.—Flaxseed: Acreage, production, and total farm value, by States, 1919.

State.	Acreage.	Average yield per acre.	Production.	Average farm price per bushel Dec. 1.	Farm value Dec. 1.
	<i>Acres.</i>	<i>Bushels.</i>	<i>Bushels.</i>	<i>Dollars.</i>	<i>Dollars.</i>
Wisconsin.....	6,000	10.5	63,000	4.30	271,000
Minnesota.....	320,000	9.0	2,880,000	4.45	12,816,000
Iowa.....	16,000	9.5	152,000	4.20	638,000
Missouri.....	5,000	9.5	48,000	4.48	215,000
North Dakota.....	760,000	5.0	3,800,000	4.41	16,758,000
South Dakota.....	145,000	8.0	1,160,000	4.25	4,930,000
Nebraska.....	3,000	5.0	15,000	4.00	60,000
Kansas.....	14,000	6.3	88,000	3.80	334,000
Montana.....	410,000	1.7	697,000	4.40	3,067,000
Wyoming.....	4,000	4.0	16,000	3.50	56,000
United States.....	1,683,000	5.3	8,919,000	4.39	39,145,000

TABLE 77.—Flaxseed: Yield per acre, price per bushel Dec. 1, and value per acre, by States.

State.	Yield per acre (bushels).											Farm price per bushel (cents).					Value per acre (dollars). <sup>1</sup>		
	10-year average, 1910-1919.	1910	1911	1912	1913	1914	1915	1916	1917	1918	1919	10-year average, 1910-1919.	1915	1916	1917	1918	1919	5-year average, 1914-1918.	1919
Wis.....	12.1	10.0	12.0	12.5	14.0	13.5	13.5	12.0	.....	11.0	10.5	218	180	240	.....	330	430	26.57	45.16
Minn.....	9.2	7.5	8.0	10.2	9.0	9.3	10.5	8.5	9.5	10.4	9.0	228	176	240	295	341	445	22.85	40.05
Iowa.....	10.1	12.2	8.0	11.5	9.4	9.5	9.0	10.0	11.0	11.0	9.5	215	150	215	275	320	420	22.37	39.90
Mo.....	7.1	8.4	3.0	6.0	5.0	8.0	8.0	7.0	8.5	8.0	9.5	210	135	212	275	300	448	16.27	42.56
N. Dak.....	7.3	3.6	7.6	9.7	7.2	8.3	9.9	10.3	3.9	7.8	5.0	230	178	252	300	345	441	18.56	22.05
S. Dak.....	7.8	5.0	5.3	8.6	7.2	7.5	11.0	9.3	7.0	9.5	8.0	223	167	247	299	325	425	20.47	34.00
Nebr.....	7.4	8.0	5.0	9.5	6.0	7.0	11.0	8.0	5.5	9.5	5.0	212	147	230	250	330	400	17.60	20.00
Kans.....	5.9	8.2	3.0	6.0	6.0	6.0	5.7	5.8	7.0	5.0	6.3	215	145	234	290	330	380	13.23	23.94
Mont.....	7.1	7.0	7.7	12.0	9.0	8.0	10.5	9.5	3.0	3.0	1.7	226	170	248	295	338	440	14.00	7.48
Wyo.....	8.7	10.0	.....	12.0	9.9	7.0	13.0	7.0	6.5	9.0	4.0	261	145	225	261	325	350	20.20	14.00
U. S.....	7.5	5.2	7.0	9.8	7.8	8.4	10.1	9.7	4.6	7.0	5.3	227.3	174.0	248.6	296.6	340.1	438.9	17.95	23.26

<sup>1</sup> Based upon farm price Dec. 1.

TABLE 78.—Flaxseed: Farm price, cents per bushel on first of each month, 1910-1919.

Date.	1919	1918	1917	1916	1915	1914	1913	1912	1911	1910	Average.
Jan. 1.....	327.7	310.8	250.7	185.9	134.8	124.2	106.2	187.1	221.1	171.2	202.0
Feb. 1.....	310.1	326.7	253.7	210.9	163.7	127.8	109.3	190.8	233.9	192.9	212.0
Mar. 1.....	327.4	349.8	253.1	202.5	157.9	132.5	119.0	183.9	240.7	193.1	216.0
Apr. 1.....	348.7	379.7	266.1	202.1	167.7	132.8	113.6	191.3	234.6	193.9	223.0
May 1.....	361.4	373.3	300.6	191.8	169.6	134.7	114.3	181.0	241.9	209.5	227.8
June 1.....	389.3	363.6	298.8	176.5	169.5	136.8	115.8	205.0	225.0	195.5	227.6
July 1.....	444.1	349.3	278.0	163.2	152.5	136.0	113.4	198.4	205.6	183.5	222.4
Aug. 1.....	540.6	410.5	271.6	178.1	144.6	150.7	118.6	175.2	199.2	209.7	239.9
Sept. 1.....	517.5	381.2	302.8	190.2	143.5	139.3	127.8	162.6	203.6	220.0	238.8
Oct. 1.....	438.2	380.9	308.5	199.2	148.1	127.4	122.6	147.7	205.0	234.3	231.2
Nov. 1.....	382.3	333.8	295.9	234.7	162.9	118.7	118.7	133.4	210.6	229.4	222.0
Dec. 1.....	438.9	340.1	296.6	248.6	174.0	126.0	119.9	114.7	182.1	231.7	227.3
Average.....	398.6	345.5	288.7	218.4	159.5	125.6	117.7	148.6	207.8	217.9	222.8

## FLAX—Continued.

TABLE 79.—Flax: Monthly marketings by farmers, 1914-1919.

Month.	Estimated amount sold monthly by farmers of United States (millions of bushels).					Per cent of year's sales.				
	1918-19	1917-18	1916-17	1915-16	1914-15	1918-19	1917-18	1916-17	1915-16	1914-15
July.....	0.2	0.1	0.2	0.2	0.2	1.8	1.8	1.2	1.5	1.5
August.....	.4	.3	.3	.2	.2	2.9	3.6	2.2	1.6	1.4
September.....	2.0	1.6	1.7	1.3	2.2	14.8	21.5	12.7	10.1	16.6
October.....	2.9	2.1	4.7	3.8	4.1	21.5	28.1	35.6	28.3	31.9
November.....	2.0	1.3	3.2	3.6	3.2	15.0	17.6	24.3	27.0	24.7
December.....	1.5	.6	1.5	1.6	1.2	10.9	7.6	11.4	11.9	9.3
January.....	.7	.3	.6	.6	.5	5.2	4.7	4.4	4.6	3.6
February.....	.6	.3	.2	.7	.4	4.4	4.0	1.7	5.1	3.2
March.....	.8	.4	.3	.4	.4	5.8	4.8	2.0	3.3	3.0
April.....	.6	.1	.1	.2	.2	4.3	1.8	.9	1.6	1.6
May.....	.7	.1	.2	.2	.1	5.0	1.6	1.6	1.6	1.2
June.....	1.1	.2	.3	.5	.3	8.4	2.9	2.0	3.4	2.0
Season.....	13.5	7.4	13.3	13.3	13.0	100.0	100.0	100.0	100.0	100.0

TABLE 80.—Flaxseed: Wholesale price per bushel, 1913-1919.

Date.	Cincinnati.			Minneapolis.			Milwaukee.			Duluth.		
	No grade.			No grade.			No. 1 Northwest-ern.			No grade.		
	Low.	High.	Average.	Low.	High.	Average.	Low.	High.	Average.	Low.	High.	Average.
1913.												
January-June.....	\$1.50	\$1.50	\$1.50	\$1.23	\$1.40	.....	\$1.26	\$1.43	\$1.31	\$1.23	\$1.39	\$1.30
July-December.....	1.50	1.50	1.50	1.31	1.53	.....	1.31	1.54	1.41	1.34	1.53	1.42
1914.												
January-June.....	1.50	1.50	1.50	1.47	1.61	\$1.55	1.45	1.75	1.57	1.48	1.63	1.56
July-December.....	1.40	1.50	1.41	1.28	1.88	1.52	1.30	1.93	1.56	1.29	1.93	1.53
1915.												
January-June.....	1.70	1.80	.....	1.60	2.08	1.87	1.52	2.05	1.86	1.62	2.09	1.89
July-December.....	1.70	1.70	.....	1.52	2.21	1.82	1.52	2.18	1.81	1.53	2.20	1.82
1916.												
January-June.....	2.85	2.85	2.85	1.74	2.41	2.14	1.74	2.38	2.11	1.76	2.43	2.12
July-December.....	1.50	2.85	2.05	1.60	2.94	2.38	1.77	2.89	2.37	1.80	2.94	2.41
1917.												
January-June.....	2.25	3.25	2.62	2.22	3.61	3.03	2.75	3.55	3.00	2.78	3.64	3.04
July-December.....	3.25	4.25	3.52	2.64	3.76	3.29	2.68	3.71	3.26	2.69	3.79	3.28
1918.												
January-June.....	3.75	4.25	3.83	3.46	4.34	3.96	3.50	4.32	3.88	3.46	4.36	3.91
July-December.....	3.25	4.75	3.91	3.31	4.70	3.97	3.33	4.67	3.97	3.31	4.73	3.97
1919.												
January.....	3.25	3.25	3.25	3.19	3.65 <sup>1</sup>	3.41	3.13	3.67	3.43	3.20	3.62 <sup>1</sup>	3.40
February.....	3.50	4.00	3.62	3.24	3.66 <sup>1</sup>	3.46	3.24	3.68	3.47	3.26 <sup>1</sup>	3.66	3.46
March.....	3.50	4.50	4.00	3.62	3.87 <sup>1</sup>	3.75	3.60	3.99	3.78	3.61	3.99	3.76
April.....	4.50	4.50	4.50	3.74	4.08	3.87	3.76 <sup>1</sup>	4.13 <sup>1</sup>	3.92	3.75 <sup>1</sup>	4.07	3.89
May.....	4.50	4.75	4.60	3.91	4.35 <sup>1</sup>	4.12	3.97	4.39	4.14	3.88	4.34	4.11
June.....	4.50	5.50	5.17	4.44	5.41	4.86	4.44	5.41	4.80	4.38	5.41	4.85
January-June.....	3.25	5.50	4.19	3.19	5.41	3.91	3.13	5.41	3.92	3.20	5.41	3.91
July.....	.....	( <sup>1</sup> )	.....	5.35	6.21	5.94	5.37	6.20 <sup>1</sup>	5.96	5.35	6.73	5.98
August.....	5.50	5.85	5.62	5.17	6.13	5.88	5.20	6.11	5.91	5.18	6.15	5.98
September.....	5.50	5.50	5.50	4.02	5.52	4.90	4.05	5.48	4.99	4.13	5.52	4.87
October.....	4.75	4.75	4.75	3.74	5.22	4.33	3.91	4.50	4.30	4.29	4.38	4.28
November.....	4.75	4.75	4.75	4.50 <sup>1</sup>	5.15	4.84	4.45	5.10	4.86	4.32	5.10	4.78
December.....	4.50	4.50	4.50	4.55	5.47	5.00	4.60	5.50	5.05	4.60	5.52	5.03
July-December.....	4.50	5.85	5.02	3.74	6.21	5.15	3.91	6.20 <sup>1</sup>	5.18	4.13	6.73	5.15

<sup>1</sup> No quotations.

RICE.

TABLE 81.—Rice: Area and production in undermentioned countries, 1909–1918.

[Expressed in terms of hulled rice; (000 omitted)].

Country.	Area.				Production.			
	Average 1909– 1913. <sup>1</sup>	1916	1917	1918	Average 1909– 1913. <sup>1</sup>	1916	1917	1918
NORTH AMERICA.								
	<i>Acres.</i>	<i>Acres.</i>	<i>Acres.</i>	<i>Acres.</i>	<i>Pounds.</i>	<i>Pounds.</i>	<i>Pounds.</i>	<i>Pounds.</i>
United States.....	749	869	981	1,113	681,166	1,135,028	964,972	1,222,889
Hawaii.....	9	(2)	(2)	(2)	25,820	(2)	(2)	(2)
Porto Rico.....	16	(2)	(2)	(2)	4,298	(2)	(2)	(2)
Central America:								
Guatemala.....	(2)	(2)	29	(2)	2,680	13,477	20,733	(2)
Costa Rica.....	7	(2)	(2)	(2)	(2)	(2)	(2)	(2)
Honduras.....	(2)	(2)	(2)	(2)	8,100	(2)	(2)	(2)
Mexico.....	(2)	66	(2)	(2)	164,299	34,222	(2)	<sup>3</sup> 40,155
SOUTH AMERICA.								
Argentina.....	20	17	(2)	(2)	24,057	(2)	(2)	(2)
Brazil: Sao Paulo.....	228	(2)	(2)	(2)	99,514	153,235	204,327	(2)
British Guiana.....	38	(2)	(2)	(2)	69,078	(2)	(2)	(2)
Dutch Guiana.....	(2)	(2)	(2)	(2)	2,754	16,471	<sup>3</sup> 11,287	<sup>3</sup> 17,649
Peru.....	138	(2)	86	(2)	100,976	69,436	95,166	(2)
EUROPE.								
Bulgaria <sup>4</sup> .....	7	9	(2)	(2)	7,767	16,000	(2)	(2)
France <sup>4</sup> .....	1	(2)	(2)	(2)	2,017	(2)	(2)	(2)
Italy.....	361	353	341	342	646,470	708,058	716,359	712,412
Russia (northern Cauca- sia) <sup>4</sup> .....	2	(2)	(2)	(2)	1,049	(2)	(2)	(2)
Spain.....	95	100	106	111	297,468	328,931	322,130	282,581
ASIA.								
India:								
British India.....	70,591	80,080	80,141	79,996	72,949,786	77,931,840	81,197,760	53,361,280
Native States.....	2,498	(2)	(2)	(2)	2,634,720	(2)	(2)	(2)
Ceylon.....	706	(2)	(2)	(2)	343,614	(2)	(2)	(2)
Federated Malay States...	125	(2)	(2)	(2)	80,398	(2)	(2)	(2)
Japanese Empire:								
Japan.....	7,357	7,527	7,557	7,559	14,008,517	18,359,997	17,142,858	17,184,044
Formosa.....	1,198	1,166	(2)	(2)	1,186,174	1,460,563	(2)	(2)
Chosen (Korea).....	2,416	2,839	(2)	(2)	2,455,522	3,936,361	(2)	(2)
Java and Madura.....	6,021	7,521	(2)	(2)	7,349,417	(2)	(2)	(2)
Philippine Islands.....	2,688	2,819	3,029	3,831	1,123,805	1,288,827	1,745,488	2,209,585
Russia Transcaucasia and Turkestan <sup>4</sup> .....	614	(2)	(2)	(2)	378,401	(2)	(2)	(2)
Straits Settlements.....	92	89	(2)	(2)	123,204	(2)	(2)	(2)
Siam.....	<sup>5</sup> 5,286	(2)	(2)	(2)	6,510,985	(2)	(2)	(2)
AFRICA.								
Egypt (Lower).....	241	150	273	(2)	552,833	236,528	487,163	(2)
Madagascar.....	(2)	1,176	(2)	(2)	953,000	1,017,470	1,404,592	(2)
Nyasaland.....	(2)	(2)	(2)	(2)	2,212	2,831	2,121	(2)
OCEANIA.								
Australia.....	(2)	(2)	(2)	(2)	75	(2)	(2)	(2)
Fiji.....	12	17	18	(2)	5,916	53,146	(2)	(2)

<sup>1</sup> Five-year average except where statistics were not available.

<sup>2</sup> No official statistics.

<sup>3</sup> Unofficial estimate.

<sup>4</sup> Old boundaries.

## RICE—Continued.

TABLE 82.—Rice (cleaned): Total production in principal countries for which estimates are available, 1900-1915.

[The figures below include the principal countries for which estimates are available. The totals shown are merely approximate. China and French Indo-China are not included below. Three Provinces of China in 1910 produced 47,204,000,000 pounds of rice. The totals below may represent at least two-thirds of the total world production of rice.]

Year.	Production.	Year.	Production.	Year.	Production.
	<i>Pounds.</i>		<i>Pounds.</i>		<i>Pounds.</i>
1900.....	100,400,000,000	1906.....	105,800,000,000	1912.....	97,300,000,000
1901.....	94,400,000,000	1907.....	100,300,000,000	1913.....	100,700,000,000
1902.....	101,600,000,000	1908.....	102,900,000,000	1914.....	102,986,000,000
1903.....	101,800,000,000	1909.....	127,700,000,000	1915.....	115,193,190,000
1904.....	110,700,000,000	1910.....	126,100,000,000		
1905.....	102,400,000,000	1911.....	102,100,000,000		

TABLE 83.—Rice: Acreage, production, value, and condition, in the United States, 1904-1919.

Year.	Acreage.	Average yield per acre.	Production.	Average farm price per bushel Dec. 1.	Farm value Dec. 1.	Condition of growing crop.			
						July 1.	Aug. 1.	Sept. 1.	When harvested.
	<i>Acres.</i>	<i>Bushels.</i>	<i>Bushels.</i>	<i>Cents.</i>	<i>Dollars.</i>	<i>Per ct.</i>	<i>Per ct.</i>	<i>Per ct.</i>	<i>Per ct.</i>
1904.....	662,000	31.9	21,096,000	65.8	13,802,000	88.2	90.2	89.7	87.3
1905.....	482,000	28.2	13,607,000	95.2	12,956,000	88.0	92.9	92.2	89.3
1906.....	575,000	31.1	17,855,000	90.3	16,121,000	82.9	83.1	86.8	87.2
1907.....	627,000	29.9	18,738,000	85.8	16,081,000	88.7	88.6	87.0	88.7
1908.....	655,000	33.4	21,890,000	81.2	17,771,000	92.9	94.1	93.5	87.7
1909.....	720,000	33.8	24,368,000						
1909.....	610,000	35.8	21,839,000	79.6	17,383,000	90.7	84.5	84.7	81.2
1910.....	723,000	33.9	24,510,000	67.8	16,624,000	86.3	87.6	88.8	88.1
1911.....	696,000	32.9	22,934,000	79.7	18,274,000	87.7	88.3	87.2	85.4
1912.....	723,000	34.7	25,054,000	93.5	23,423,000	86.3	86.3	88.8	89.2
1913.....	827,000	31.1	25,744,000	85.8	22,090,000	88.4	88.7	88.0	80.3
1914.....	694,000	34.1	23,649,000	92.4	21,849,000	86.5	87.6	88.9	88.0
1915.....	803,000	36.1	28,947,000	90.6	26,212,000	90.5	90.0	82.3	80.9
1916.....	869,000	47.0	40,861,000	88.9	36,311,000	92.7	92.2	91.2	91.5
1917.....	981,000	35.4	34,739,000	189.6	65,879,000	85.1	85.0	78.4	79.7
1918.....	1,119,000	34.5	38,608,000	191.8	74,042,000	91.1	85.7	83.7	85.4
1919.....	1,090,000	37.7	41,059,000	267.0	109,613,000	89.5	90.4	91.9	91.3

TABLE 84.—Rice: Acreage, production, and farm value, by States, 1919.

State.	Acreage.	Average yield per acre.	Production.	Average farm price per bushel Dec. 1.	Farm value Dec. 1.
	<i>Acres.</i>	<i>Bushels.</i>	<i>Bushels.</i>	<i>Dollars.</i>	<i>Dollars.</i>
North Carolina.....	400	24.4	10,000	2.75	28,000
South Carolina.....	3,700	24.4	90,000	3.00	270,000
Georgia.....	1,200	24.4	29,000	2.75	80,000
Florida.....	2,000	21.1	42,000	2.63	110,000
Missouri.....	600	38.0	23,000	2.40	55,000
Alabama.....	600	26.4	16,000	2.70	43,000
Mississippi.....	3,300	29.1	95,000	1.90	180,000
Louisiana.....	560,000	35.2	19,712,000	2.71	53,420,000
Texas.....	218,000	32.1	6,998,000	2.80	19,594,000
Arkansas.....	158,000	39.0	6,162,000	2.40	14,789,000
California.....	142,000	55.5	7,881,000	2.67	21,042,000
United States.....	1,089,800	37.7	41,059,000	2.67	109,613,000

RICE—Continued.

TABLE 85.—Rice: Yield per acre, price per bushel Dec. 1, and value per acre by States.

State.	Yield per acre (bushels).											Farm price per bushel (cents).					Value per acre (dollars). <sup>1</sup>		
												10-year average, 1910-1919.					5-year average, 1914-1918.		
	10-year average, 1910-1919.	1910	1911	1912	1913	1914	1915	1916	1917	1918	1919	10-year average, 1910-1919.	1915	1916	1917	1918	1919	5-year average, 1914-1918.	1919
N. C.	24.0	23.5	25.0	25.0	24.0	26.3	21.0	21.0	26.0	20.0	24.4	124	85	85	195	200	275	29.22	67.10
S. C.	22.4	21.0	11.7	25.0	30.0	26.0	21.3	14.0	25.0	23.0	24.4	130	90	90	195	195	300	30.40	73.20
Ga.	25.8	22.0	26.8	30.0	32.0	28.0	29.3	20.0	30.0	26.0	24.4	123	88	87	195	175	275	34.42	67.10
Fla.	24.2	21.0	25.0	25.0	25.0	25.0	25.0	25.0	26.0	24.0	21.1	112	75	75	195	140	263	27.86	55.49
Mo.	45.8						50.0	51.0	45.0	45.0	38.0	162	100	100	190	180	240	66.88	91.20
Ala.	25.3	25.0	20.0	30.0	22.0	28.0	25.0	25.0	27.0	25.0	26.4	112	75	75	190	150	270	29.18	71.28
Miss.	29.4	30.0	36.0	35.0	28.0	30.0	25.0	28.0	30.0	23.0	29.1	109	88	80	190	150	190	32.28	55.29
La.	33.6	34.4	31.5	33.5	29.0	32.1	34.2	46.0	31.0	28.8	35.2	125	90	90	190	195	271	43.42	95.39
Tex.	33.8	33.0	34.3	35.5	32.0	33.8	30.5	45.0	30.0	32.0	32.1	127	89	86	200	197	280	44.00	89.88
Ark.	40.9	40.0	39.0	37.5	36.0	39.8	48.4	50.5	41.0	37.9	39.0	123	95	96	190	180	240	55.28	93.60
Calif.	53.9	33.0	40.0	50.0	48.0	53.3	66.7	59.0	68.0	65.5	55.5	123	90	78	175	190	267	80.64	148.18
U. S.	35.7	33.9	32.9	34.7	31.1	34.1	36.1	47.0	35.4	34.5	37.7	124.7	90.6	88.9	189.6	191.8	267.0	47.86	100.58

<sup>1</sup> Based upon farm price Dec. 1.

TABLE 86.—Rice: Wholesale price per pound, 1913-1919.

Date.	New York.			Cincinnati.			Lake Charles.			New Orleans.			Houston.		
	Domestic (good).			Prime.			Rough (per 102 lbs.)			Honduras (cleaned).			Head rice (cleaned).		
	Low.	High.	Average.	Low.	High.	Average.	Low.	High.	Average.	Low.	High.	Average.	Low.	High.	Average.
1913.	Cts.	Cts.	Cts.	Cts.	Cts.	Cts.	Dols.	Dols.	Dols.	Cts.	Cts.	Cts.	Cts.	Cts.	Cts.
January-June	4½	5	.....	5½	6½	.....	2.50	3.82	.....	2½	5½	.....	4	5½	.....
July-December	4½	5½	.....	5½	6½	.....	2.00	3.76	.....	3	4½	3.85	4½	6	.....
1914.															
January-June	4½	5	.....	5½	6½	.....	1.40	3.76	.....	1½	6½	.....	3½	5½	.....
July-December	4½	5½	.....	5½	6½	.....	2.00	4.55	.....	1½	6½	.....	3	5½	.....
1915.															
January-June	5	5½	.....	5½	6½	.....	2.85	4.61½	.....	2½	5½	.....	4½	5	.....
July-December	4½	5½	.....	5	6½	.....	2.80	3.65	.....	2	5½	.....	4½	5½	.....
1916.															
January-June	5	5½	.....	5½	5½	.....	2.65	4.25	.....	2	5½	.....	3½	4½	.....
July-December	5	5½	.....	5½	5½	.....	2.60	3.65	.....	2½	5½	.....	3½	4½	.....
1917.															
January-June	5½	9	.....	5½	8½	.....	2.70	7.00	.....	2½	8½	.....	4½	8	.....
July-December	7½	9½	.....	8	8½	.....	5.34	7.50	.....	4½	8½	.....	7	8½	.....
1918.															
January-June	8½	10½	9.4	8½	10	9.0	15.00	18.50	17.57	5½	9½	7.7	8	9½	8½
July-December	9½	10½	10.2	10	10½	10.1	15.00	17.50	17.16	4½	10½	7.6	9½	9½	9½
1919.															
January	10½	10½	10.4	10	10½	10.2	4.00	7.25	7.00	5	9½	7.8	4 9½	4 9½	4 9½
February	10½	10½	10.4	10	11½	10.8	3.00	7.25	6.75	4½	11½	7.7	9½	9½	9½
March	10½	10½	10.4	10½	11½	11.0	.....	.....	.....	5	9½	8.0	9½	9½	9½
April	10½	10½	10.4	10½	11½	11.0	2.50	7.00	6.50	6½	9½	7.9	9½	9½	9½
May	10½	11½	10.7	10½	11½	11.0	3.00	7.00	6.50	4½	9½	7.0	9½	9½	9½
June	11	12	11.7	10½	11½	11.0	4.00	7.25	6.75	5½	11½	9.2	9½	13	11 17
January-June	10½	12	10.7	10	11½	10.8	2.50	7.25	6.70	4½	11½	7.9	9½	13	9.4
July	13	14	13.7	10½	11½	11.1	6.00	9.00	7.50	6½	13½	10.1	12½	14	13½
August	14	14½	14.3	10½	14	11.6	11.00	13.00	13.00	6	14½	10.9	12½	13½	13
September	13½	14½	14.1	13	14½	13.5	7.00	12.00	11.00	6½	13½	12.2	12½	13½	13½
October	13½	13½	13.6	14	14½	14.2	.....	.....	.....	11½	12½	11.8	9.8	11.5	10.6
November	13½	14	13.8	13½	14½	14.1	.....	.....	.....	11	13½	11.9	9.2	11.8	10.5
December	13½	14½	14.2	13½	14½	14.0	.....	.....	.....	11	13½	12.3	9.8	12.8	11.2
July-December	13	14½	14.0	10½	14½	13.1	.....	.....	.....	6	14½	11.5	9.2	14	11.9

<sup>1</sup> Five months, average.

<sup>2</sup> Fancy head, 1919.

<sup>3</sup> Fancy, 1919.

<sup>4</sup> Honduras, 1919.

## RICE—Continued.

TABLE 87.—Rice: International trade, calendar years 1909–1913, 1917, and 1918.

[Mostly cleaned rice. Under rice is included paddy, unhulled, rough, cleaned, polished, broken, and cargo rice, in addition to rice flour and meal. Rice bran is not included. Rough rice or paddy, where specifically reported, has been reduced to terms of cleaned rice at ratio of 162 pounds, rough or unhulled, to 100 pounds of cleaned. "Rice, other than whole or cleaned rice," in the returns of United Kingdom, is not considered paddy, since the chief sources of supply indicate that it is practically all hulled rice. Cargo rice, a mixture of hulled and unhulled, is included without being reduced to terms of cleaned. Broken rice and rice flour and meal are taken without being reduced to terms of whole cleaned rice. See "General note" Table 12.]

## EXPORTS.

[000 omitted.]

Country.	Average 1909–1913	1917 (prelim.)	1918 (prelim.)	Country.	Average 1909–1913	1917 (prelim.)	1918 (prelim.)
<i>From—</i>	<i>Pounds.</i>	<i>Pounds.</i>	<i>Pounds.</i>	<i>From—</i>	<i>Pounds.</i>	<i>Pounds.</i>	<i>Pounds.</i>
Belgium.....	99,948			Penang.....	357,548		
British India.....	5,337,516	3,847,321	5,488,517	Siam.....	1,928,507	2,496,924	1,893,336
Dutch East Indies..	132,400	12,747		Singapore.....	758,875		
France.....	79,087	9,850	3,840	Other countries..	866,020		
French Indo-China..	2,288,040			Total.....	12,720,845		
Germany.....	396,628						
Netherlands.....	476,276						

## IMPORTS.

<i>Into—</i>				<i>Into—</i>			
Austria-Hungary....	183,411			Netherlands.....	778,682		
Belgium.....	180,830			Penang.....	511,035		
Brazil.....	24,753			Perak.....	179,187		
British India.....	278,272	188,271	341,532	Philippine Islands	412,781	324,045	428,807
Ceylon.....	821,654	922,529	762,405	Russia.....	250,461		
China.....	794,992	1,311,624	931,203	Selangor.....	159,178		
Cuba.....	262,207	324,810	387,892	Singapore.....	975,095		
Dutch East Indies..	1,178,111	1,669,448		United Kingdom..	768,853	818,152	849,032
Egypt.....	98,690	32,207	10,510	United States.....	209,814	266,471	536,089
France.....	517,861	525,483	377,676	Other countries....	1,242,092		
Germany.....	913,772			Total.....	11,439,950		
Japan.....	655,676	188,125	1,549,056				
Mauritius.....	132,543						

## CEREALS CONSUMED.

TABLE 88.—Consumption of specified cereals in selected countries; yearly average, 1909–1913.

## BARLEY (INCLUDING MALT CONVERTED TO BARLEY).

Country.	Average yearly production, 1909–1913.	Average yearly net imports (+) or exports (-), calendar years 1909–1913.	Average yearly total consumption, 1909–1913.	Mean yearly population, 1909–1913.	Average yearly consump- tion per capita, 1909–1913.
	<i>Bushels.</i>	<i>Bushels.</i>	<i>Bushels.</i>		<i>Bushels.</i>
Austria-Hungary.....	147,795,000	+ 17,663,000	130,132,000	51,783,777	2.51
Belgium.....	4,247,000	- 15,733,000	19,980,000	7,497,119	2.66
France.....	46,489,000	+ 5,628,000	52,117,000	39,561,600	1.32
Germany.....	153,529,000	+143,626,000	297,155,000	65,781,875	4.52
India (British).....	No data.	No data.	No data.	244,267,542	.....
Italy.....	10,104,000	+ 789,000	10,893,000	34,681,653	.31
Japan.....	89,528,000	No data.	89,528,000	51,775,737	1.73
Netherlands.....	3,270,000	+ 12,099,000	15,369,000	6,030,634	2.55
United Kingdom.....	64,760,000	+ 30,477,000	95,237,000	45,175,723	2.11
United States.....	181,881,000	- 7,653,000	174,228,000	93,832,959	1.86

CEREALS CONSUMED—Continued.

TABLE 88.—Consumption of specified cereals in selected countries; yearly average—Continued.

1909-1913—Continued.

CORN (INCLUDING CORN MEAL CONVERTED TO CORN).

Country.	Average yearly production, 1909-1913.	Average yearly net imports (+) or exports (-), calendar years 1909-1913.	Average yearly total consumption, 1909-1913.	Mean yearly population, 1909-1913.	Average yearly consumption per capita, 1909-1913.
	<i>Bushels.</i>	<i>Bushels.</i>	<i>Bushels.</i>		<i>Bushels.</i>
Austria-Hungary.....	216,601,000	+13,608,000	230,209,000	51,783,777	4.44
Belgium.....	No data.	+17,672,000	17,672,000	7,497,119	2.36
France.....	22,229,000	+18,600,000	40,829,000	39,561,600	1.03
Germany.....	No data.	+32,159,000	32,159,000	65,781,875	.49
India (British).....	87,240,000	No data.	87,240,000	244,267,542	.36
Italy.....	100,349,000	+14,658,000	115,007,000	34,681,653	3.32
Japan.....	3,637,000	No data.	3,637,000	51,775,737	.01
Netherlands.....	No data.	+20,829,000	20,829,000	6,030,634	3.45
United Kingdom.....	No data.	+82,861,000	82,861,000	45,175,723	1.83
United States.....	2,708,334,000	-43,870,000	2,664,464,000	93,832,959	28.40

OATS.

Austria-Hungary.....	239,421,000	+ 2,262,000	241,683,000	51,783,777	4.67
Belgium.....	40,905,000	+ 7,859,000	48,764,000	7,497,119	6.50
France.....	310,020,000	+27,250,000	337,270,000	39,561,600	8.53
Germany.....	591,996,000	+ 971,000	592,967,000	65,781,875	9.01
India (British).....	No data.	No data.	No data.	244,267,542	.....
Italy.....	36,945,000	+ 8,153,000	45,098,000	34,681,653	1.30
Japan.....	No data.	No data.	No data.	51,775,737	.....
Netherlands.....	18,512,000	+ 7,532,000	26,044,000	6,030,634	4.32
United Kingdom.....	182,777,000	+65,881,000	248,658,000	45,175,723	5.50
United States.....	1,131,175,000	-19,180,000	1,111,995,000	93,832,959	11.85

RICE (MOSTLY CLEANED, AND INCLUDING RICE FLOUR, RICE MEAL, AND BROKEN RICE).

	<i>Pounds.</i>	<i>Pounds.</i>	<i>Pounds.</i>		<i>Pounds.</i>
Austria-Hungary.....	No data.	+ 182,921,000	182,921,000	51,783,777	3.53
Belgium.....	No data.	+ 80,882,000	80,882,000	7,497,119	10.79
France.....	2,017,000	+ 438,774,000	440,791,000	39,561,600	11.14
Germany.....	No data.	+ 517,145,000	517,145,000	65,781,875	7.86
India (British).....	72,949,786,000	-5,059,244,000	67,890,542,000	244,267,542	277.94
Italy.....	646,470,000	- 128,162,000	518,308,000	34,681,653	14.94
Japan.....	14,008,517,000	+ 593,675,000	14,602,192,000	51,775,737	282.03
Netherlands.....	No data.	+ 302,407,000	302,407,000	6,030,634	50.15
United Kingdom.....	No data.	+ 678,290,000	678,290,000	45,175,723	15.01
United States.....	681,166,000	+ 193,599,000	874,765,000	93,832,959	9.32

RYE (INCLUDING RYE FLOUR CONVERTED TO RYE).

	<i>Bushels.</i>	<i>Bushels.</i>	<i>Bushels.</i>		<i>Bushels.</i>
Austria-Hungary.....	164,143,000	+ 1,487,000	165,630,000	51,783,777	3.20
Belgium.....	22,675,000	+ 4,315,000	26,990,000	7,497,119	3.60
France.....	48,647,000	+ 3,019,000	51,666,000	39,561,600	1.31
Germany.....	445,222,000	-26,836,000	418,386,000	65,781,875	6.36
India (British).....	No data.	No data.	No data.	244,267,542	.....
Italy.....	5,328,000	+ 746,000	6,074,000	34,681,653	.18
Japan.....	No data.	No data.	No data.	51,775,737	.....
Netherlands.....	16,422,000	+11,238,000	27,660,000	6,030,634	4.59
United Kingdom.....	1,751,000	+ 2,122,000	3,873,000	45,175,723	.09
United States.....	34,916,000	- 601,000	34,315,000	93,832,959	.37

WHEAT (INCLUDING WHEAT FLOUR CONVERTED TO WHEAT).

Austria-Hungary.....	217,598,000	+ 8,032,000	225,630,000	51,783,777	4.36
Belgium.....	14,583,000	+ 51,273,000	65,856,000	7,497,119	8.78
France.....	317,254,000	+ 37,168,000	354,422,000	39,561,600	8.96
Germany.....	152,119,000	+ 68,606,000	220,725,000	65,781,875	3.36
India (British).....	350,736,000	- 50,983,000	299,753,000	244,267,542	1.23
Italy.....	183,260,000	+ 49,309,000	232,569,000	34,681,653	6.71
Japan.....	25,274,000	+ 3,469,000	28,743,000	51,775,737	.56
Netherlands.....	4,976,000	+ 22,259,000	27,235,000	6,030,634	4.52
United Kingdom.....	61,481,000	+214,639,000	276,120,000	45,175,723	6.11
United States.....	686,691,000	- 98,673,000	588,018,000	93,832,959	6.27

NOTE.—Bushel=Barley, 48; oats, 32; corn and rye, 56; and wheat, 60 pounds.

TABLE 88.—Consumption of specified cereals in selected countries: Yearly average—Con.

1914-1918.

## BARLEY (INCLUDING MALT CONVERTED TO BARLEY).

Country.	Average yearly production, 1914-1918.	Average yearly net imports (+) or exports (-), calendar years 1914-1918.	Average yearly total consumption, 1914-1918.	Mean yearly population, 1914-1918.	Average yearly consumption per capita, 1914-1918.
	<i>Bushels.</i>	<i>Bushels.</i>	<i>Bushels.</i>		<i>Bushels.</i>
Austria-Hungary <sup>1</sup> .....	109,760,000	No data.	109,760,000	53,279,370	2.00
Belgium <sup>1</sup> .....	4,116,000	No data.	4,116,000	7,752,390	.53
France.....	36,087,000	+ 7,475,000	43,562,000	37,769,600	1.15
Germany <sup>2</sup> .....	113,222,000	No data.	113,222,000	69,149,378	1.64
India (British).....	145,273,000	- 9,163,000	136,110,000	250,598,343	.54
Italy.....	9,123,000	+ 2,161,000	11,284,000	36,407,653	.31
Japan.....	87,004,000	+ 262,000	87,266,000	55,527,016	1.57
Netherlands <sup>3</sup> .....	2,966,000	+ 749,000	3,715,000	6,448,547	.58
United Kingdom.....	58,780,000	+ 25,604,000	84,384,000	43,582,551	1.94
United States.....	214,849,000	- 22,973,000	191,876,000	102,017,312	1.88

## CORN (INCLUDING CORN MEAL CONVERTED TO CORN).

Austria-Hungary <sup>1</sup> .....	217,840,000	No data.	217,840,000	53,279,370	4.09
Belgium.....	No data.	No data.	No data.	7,861,926	.....
France.....	16,642,000	+ 14,736,000	31,378,000	37,769,600	.83
Germany <sup>2</sup> .....	No data.	No data.	No data.	69,149,378	.....
India (British).....	90,224,000	+ 1,082,000	91,306,000	250,598,343	.36
Italy.....	92,076,000	+ 6,346,000	98,422,000	36,407,653	2.70
Japan.....	3,868,000	No data.	3,868,000	55,527,016	.07
Netherlands <sup>4</sup> .....	No data.	+ 29,721,000	29,721,000	6,483,590	4.58
United Kingdom.....	No data.	+ 64,480,000	64,480,000	43,582,551	1.48
United States.....	2,776,514,000	- 39,686,000	2,736,828,000	102,017,312	26.83

## OATS.

Austria-Hungary <sup>1</sup> .....	186,600,000	No data.	186,600,000	53,279,370	3.50
Belgium <sup>1</sup> .....	44,871,000	No data.	44,871,000	7,752,390	5.79
France.....	237,814,000	+ 47,587,000	285,401,000	37,769,600	7.56
Germany <sup>2</sup> .....	413,010,000	No data.	413,010,000	69,149,378	5.97
India (British).....	No data.	No data.	No data.	250,598,343	.....
Italy.....	31,914,000	+ 21,800,000	53,714,000	36,407,653	1.48
Japan <sup>4</sup> .....	No data.	- 357,000	No data.	55,527,016	.....
Netherlands <sup>3</sup> .....	20,963,000	+ 4,926,000	25,889,000	6,448,547	4.01
United Kingdom.....	202,508,000	+ 54,220,000	256,728,000	43,582,551	5.89
United States.....	1,414,605,000	- 96,317,000	1,318,288,000	102,017,312	12.92

## RICE (MOSTLY CLEANED AND INCLUDING RICE FLOUR, RICE MEAL, AND BROKEN RICE).

	<i>Pounds.</i>	<i>Pounds.</i>	<i>Pounds.</i>	<i>Pounds.</i>	<i>Pounds.</i>
Austria-Hungary.....	No data.	No data.	No data.	53,920,339	.....
Belgium.....	No data.	No data.	No data.	7,861,926	.....
France.....	No data.	+ 469,911,000	469,911,000	37,769,600	12.44
Germany <sup>2</sup> .....	No data.	No data.	No data.	69,149,378	.....
India (British).....	69,407,744,000	-3,725,780,000	65,681,964,000	250,598,343	252.10
Italy.....	728,198,000	+ 129,412,000	857,610,000	36,407,653	23.56
Japan.....	17,632,967,000	+ 407,271,000	18,040,238,000	55,527,016	324.89
Netherlands.....	No data.	+ 166,603,000	166,603,000	6,521,217	25.55
United Kingdom.....	No data.	+ 883,137,000	883,137,000	43,582,551	20.26
United States.....	956,778,000	+ 176,164,000	1,132,942,000	102,017,312	11.11

<sup>1</sup> Two-year average 1914-15. No further data available.  
<sup>2</sup> Excluding Alsace-Lorraine.

<sup>3</sup> Three-year average 1914-1916.  
<sup>4</sup> Four-year average 1914-1917.



TABLE 88.—Consumption of specified cereals in selected countries: Yearly average—Con.

1914-1918—Continued.

RYE (INCLUDING RYE FLOUR CONVERTED TO RYE).

Country.	Average yearly production, 1914-1918.	Average yearly net imports (+) or exports (-), calendar years 1914-1918.	Average yearly total consumption, 1914-1918.	Mean yearly population, 1914-1918.	Average yearly consumption per capita, 1914-1918
	<i>Bushels.</i>	<i>Bushels.</i>	<i>Bushels.</i>		<i>Bushels.</i>
Austria-Hungary <sup>1</sup> .....	109,916,000	No data.	109,916,000	53,279,370	2.06
Belgium <sup>1</sup> .....	20,568,000	No data.	20,568,000	7,752,390	2.65
France.....	31,179,000	+ 559,000	31,738,000	37,769,600	.84
Germany <sup>2</sup> .....	341,185,000	No data.	341,185,000	69,149,378	4.93
India (British).....	No data.	No data.	No data.	250,598,343	.....
Italy.....	4,878,000	+ 1,036,000	5,914,000	36,407,653	.16
Japan.....	No data.	No data.	No data.	55,527,016	.....
Netherlands.....	12,351,000	+ 2,007,000	14,358,000	6,521,217	2.20
United Kingdom <sup>1</sup> .....	1,750,000	+ 3,231,000	4,981,000	45,285,376	.11
United States.....	59,545,000	-- 13,730,000	45,815,000	102,017,312	.45

WHEAT.

Austria-Hungary <sup>1</sup> .....	176,348,000	No data.	176,348,000	53,279,370	3.31
Belgium <sup>1</sup> .....	10,986,000	No data.	10,986,000	7,752,390	1.42
France.....	217,661,000	+ 74,667,000	292,328,000	37,769,600	7.74
Germany <sup>2</sup> .....	111,548,000	No data.	111,548,000	69,149,378	1.61
India (British).....	332,852,000	- 33,287,000	299,565,000	250,598,343	1.20
Italy.....	166,604,000	+ 46,861,000	213,465,000	36,407,653	5.86
Japan.....	29,151,000	+ 29,000	29,180,000	55,527,016	.53
Netherlands <sup>3</sup> .....	5,635,000	+ 25,748,000	31,383,000	6,448,547	4.87
United Kingdom.....	72,939,000	+ 197,883,000	270,822,000	43,582,551	6.21
United States.....	821,378,000	- 206,134,000	615,244,000	102,017,312	6.03

<sup>1</sup> Two-year average, 1914-15.    <sup>2</sup> Excludes Alsace-Lorraine.    <sup>3</sup> Three-year average, 1914-1916.

NOTE.—Bushel: Barley, 48; oats, 32; corn and rye, 56; and wheat, 60 pounds.

**STATISTICS OF CROPS OTHER THAN GRAIN CROPS.**  
**POTATOES.**

TABLE 89.—Potatoes: Area and production in undermentioned countries, 1909–1918.  
(000 omitted.)

Country.	Area.				Production.			
	Average 1909– 1913. <sup>1</sup>	1916	1917	1918	Average 1909– 1913. <sup>1</sup>	1916	1917	1918
<b>NORTH AMERICA.</b>								
United States.....	<i>Acres.</i> 3,680	<i>Acres.</i> 3,565	<i>Acres.</i> 4,374	<i>Acres.</i> 4,210	<i>Bushels.</i> 356,627	<i>Bushels.</i> 286,953	<i>Bushels.</i> 438,618	<i>Bushels.</i> 400,106
Canada:								
Prince Edward Island..	32	31	35	30	5,901	6,386	6,125	5,295
Nova Scotia.....	32	34	41	50	6,627	6,935	7,173	9,306
New Brunswick.....	42	39	46	56	8,898	7,488	6,891	10,269
Quebec.....	120	112	227	280	19,723	14,672	18,158	36,149
Ontario.....	156	133	142	155	20,720	8,113	18,981	17,224
Manitoba.....	26	32	34	44	4,755	4,709	3,643	6,897
Saskatchewan.....	29	47	68	59	4,812	7,319	9,010	8,054
Alberta.....	24	29	49	45	3,934	4,783	7,409	6,188
British Columbia.....	14	15	15	14	3,128	2,892	2,502	2,807
Total Canada.....	475	472	657	713	78,498	63,297	79,892	102,189
Mexico.....	( <sup>2</sup> )	( <sup>2</sup> )	( <sup>2</sup> )	( <sup>2</sup> )	924	( <sup>2</sup> )	( <sup>2</sup> )	452
Newfoundland.....	( <sup>2</sup> )	( <sup>2</sup> )	( <sup>2</sup> )	( <sup>2</sup> )	1,495	( <sup>2</sup> )	( <sup>2</sup> )	( <sup>2</sup> )
Total.....	4,155	4,037	5,031	4,923	437,544	350,250	518,510	502,747
<b>SOUTH AMERICA.</b>								
Argentina.....	235	322	( <sup>2</sup> )	( <sup>2</sup> )	40,216	31,138	( <sup>2</sup> )	( <sup>2</sup> )
Chile.....	66	79	70	78	8,023	11,598	9,091	9,768
Total.....	301	401	.....	.....	48,239	42,736	.....	.....
<b>EUROPE.</b>								
Austria <sup>3</sup> .....	3,105	( <sup>2</sup> )	( <sup>2</sup> )	( <sup>2</sup> )	456,485	( <sup>2</sup> )	( <sup>2</sup> )	( <sup>2</sup> )
Hungary, proper <sup>3</sup> .....	1,521	( <sup>2</sup> )	( <sup>2</sup> )	( <sup>2</sup> )	180,103	( <sup>2</sup> )	( <sup>2</sup> )	( <sup>2</sup> )
Croatia-Slavonia <sup>3</sup> .....	193	( <sup>2</sup> )	( <sup>2</sup> )	( <sup>2</sup> )	22,254	( <sup>2</sup> )	( <sup>2</sup> )	( <sup>2</sup> )
Bosnia-Herzegovina <sup>3</sup> .....	69	( <sup>2</sup> )	( <sup>2</sup> )	( <sup>2</sup> )	3,359	( <sup>2</sup> )	( <sup>2</sup> )	( <sup>2</sup> )
Belgium.....	390	( <sup>2</sup> )	( <sup>2</sup> )	( <sup>2</sup> )	107,021	( <sup>2</sup> )	( <sup>2</sup> )	( <sup>2</sup> )
Bulgaria <sup>3</sup> .....	8	( <sup>2</sup> )	( <sup>2</sup> )	( <sup>2</sup> )	454	( <sup>2</sup> )	( <sup>2</sup> )	( <sup>2</sup> )
Denmark.....	145	159	143	186	32,440	26,629	31,882	40,605
Finland.....	184	( <sup>2</sup> )	( <sup>2</sup> )	( <sup>2</sup> )	20,975	( <sup>2</sup> )	( <sup>2</sup> )	( <sup>2</sup> )
France <sup>2</sup> .....	3,841	3,163	3,482	2,884	489,377	322,647	401,336	228,433
Germany <sup>1</sup> .....	8,260	<sup>4</sup> 6,782	<sup>4</sup> 6,186	<sup>4</sup> 6,740	1,681,959	<sup>4</sup> 907,236	<sup>4</sup> 1,264,374	1,082,816
Italy.....	658	729	732	739	60,813	54,277	48,112	51,808
Luxemburg.....	36	34	27	25	6,439	2,971	5,925	4,731
Malta.....	4	3	( <sup>2</sup> )	( <sup>2</sup> )	672	356	( <sup>2</sup> )	( <sup>2</sup> )
Netherlands.....	414	413	419	405	110,153	105,040	130,288	123,978
Norway.....	102	114	145	133	24,821	31,310	42,584	28,954
Roumania <sup>3,6</sup> .....	28	35	( <sup>2</sup> )	78	3,634	( <sup>2</sup> )	( <sup>2</sup> )	2,409
Do. <sup>3,6</sup> .....	58	( <sup>2</sup> )	( <sup>2</sup> )	138	1,144	( <sup>2</sup> )	( <sup>2</sup> )	7250
Russia proper <sup>5</sup> .....	8,302	5,879	( <sup>2</sup> )	( <sup>2</sup> )	862,798	662,169	( <sup>2</sup> )	( <sup>2</sup> )
Poland <sup>3</sup> .....	2,628	( <sup>2</sup> )	( <sup>2</sup> )	( <sup>2</sup> )	373,917	( <sup>2</sup> )	( <sup>2</sup> )	( <sup>2</sup> )
Northern Caucasia <sup>3</sup> .....	197	( <sup>2</sup> )	( <sup>2</sup> )	( <sup>2</sup> )	15,663	( <sup>2</sup> )	( <sup>2</sup> )	( <sup>2</sup> )
Serbia <sup>3</sup> .....	30	( <sup>2</sup> )	( <sup>2</sup> )	( <sup>2</sup> )	2,201	( <sup>2</sup> )	( <sup>2</sup> )	( <sup>2</sup> )
Spain.....	687	( <sup>2</sup> )	839	728	93,413	( <sup>2</sup> )	113,477	94,767
Sweden.....	379	373	397	398	60,327	54,972	83,700	71,129
Switzerland.....	186	200	140	168	40,537	18,372	38,580	43,355
United Kingdom:								
England.....	408	400	473	597	94,487	88,484	117,351	148,848
Scotland.....	145	130	148	169	34,674	19,825	41,443	42,970
Wales.....	26	28	35	37	5,403	5,018	7,380	8,288
Ireland.....	590	586	709	702	119,874	90,845	155,036	144,230
Total United King- dom.....	1,169	1,144	1,370	1,505	254,438	204,172	321,210	344,336
Total.....	32,594	.....	.....	.....	4,905,397	.....	.....	.....

<sup>1</sup> Five-year average, except where statistics were not available.  
<sup>2</sup> No official statistics.  
<sup>3</sup> Old boundaries.  
<sup>4</sup> Excludes Alsace-Lorraine.  
<sup>5</sup> Grown alone.  
<sup>6</sup> Grown with corn.  
<sup>7</sup> Including Bessarabia, but excluding Dobrudja.

POTATOES—Continued.

TABLE 89.—Potatoes: Area and production in undermentioned countries, 1909–1918—Con.

[000 omitted.]

Country.	Area.				Production.			
	Average 1909–1913.	1916	1917	1918	Average 1909–1913.	1916	1917	1918
<b>ASIA.</b>								
Japan.....	174	254	246	273	24,738	38,613	36,924	41,275
Russia, Asiatic:								
Central Asia (4 governments) <sup>1</sup> .....	90	( <sup>2</sup> )	( <sup>2</sup> )	( <sup>2</sup> )	5,230	( <sup>2</sup> )	( <sup>2</sup> )	( <sup>2</sup> )
Siberia (4 governments) <sup>1</sup> .....	298	( <sup>2</sup> )	( <sup>2</sup> )	( <sup>2</sup> )	27,773	( <sup>2</sup> )	( <sup>2</sup> )	( <sup>2</sup> )
Transcaucasia (1 government) <sup>1</sup> .....	2	( <sup>2</sup> )	( <sup>2</sup> )	( <sup>2</sup> )	148	( <sup>2</sup> )	( <sup>2</sup> )	( <sup>2</sup> )
Total.....	573				57,889			
<b>AFRICA.</b>								
Algeria.....	45	( <sup>2</sup> )	27	( <sup>2</sup> )	1,783	( <sup>2</sup> )	2,756	( <sup>2</sup> )
Union of South Africa.....	62	( <sup>2</sup> )	( <sup>2</sup> )	( <sup>2</sup> )	3,269	( <sup>2</sup> )	( <sup>2</sup> )	( <sup>2</sup> )
Total.....	107				5,052			
<b>AUSTRALASIA.</b>								
Australia:								
Queensland.....	8	6	9	( <sup>2</sup> )	524	278	726	( <sup>2</sup> )
New South Wales.....	39	20	22	( <sup>2</sup> )	3,378	1,658	1,691	( <sup>2</sup> )
Victoria.....	55	57	74	( <sup>2</sup> )	5,983	6,489	7,018	( <sup>2</sup> )
South Australia.....	8	4	5	4	894	485	759	422
Western Australia.....	3	5	6	( <sup>2</sup> )	309	527	629	( <sup>2</sup> )
Tasmania.....	24	29	34	( <sup>2</sup> )	2,989	2,983	2,503	( <sup>2</sup> )
Total Australia.....	137	121	150		14,077	12,420	13,326	
New Zealand.....	28	30	26	23	6,047	4,809	4,992	3,756
Total Australasia.....	165	151	176		20,124	17,229	18,318	
Grand total.....	37,895				5,474,245			

<sup>1</sup> Old boundaries.

<sup>2</sup> No official statistics.

TABLE 90.—Potatoes: Total production of countries mentioned in Table 89, 1900–1915.

Year.	Production.	Year.	Production.	Year.	Production.	Year.	Production.
	<i>Bushels.</i>		<i>Bushels.</i>		<i>Bushels.</i>		<i>Bushels.</i>
1900.....	4,382,031,000	1904.....	4,298,049,000	1908.....	5,295,043,000	1912.....	5,872,953,000
1901.....	4,669,958,000	1905.....	5,254,598,000	1909.....	5,595,567,000	1913.....	5,802,910,000
1902.....	4,674,000,000	1906.....	4,789,112,000	1910.....	5,242,278,000	1914.....	5,016,291,000
1903.....	4,409,793,000	1907.....	5,122,078,000	1911.....	4,842,109,000	1915.....	5,361,898,000

TABLE 91.—Potatoes: Average yield, per acre, of undermentioned countries in 1900–1919.

Year.	United States.	Russia (European). <sup>1</sup>	Germany. <sup>1</sup>	Austria. <sup>1</sup>	Hungary proper. <sup>1</sup>	France. <sup>1</sup>	United Kingdom. <sup>1</sup>
Average:	<i>Bushels.</i>	<i>Bushels.</i>	<i>Bushels.</i>	<i>Bushels.</i>	<i>Bushels.</i>	<i>Bushels.</i>	<i>Bushels.</i>
1900–1909.....	91.4	99.9	200.0	151.1	118.7	133.8	193.8
1910–1915.....	97.6	107.9	205.7	145.6	122.2	116.3	222.8
1906.....	102.2	94.9	193.3	158.4	128.7	99.5	192.2
1907.....	95.4	102.4	205.3	173.2	126.6	136.2	171.0
1908.....	85.7	102.9	209.2	154.0	96.6	163.7	231.1
1909.....	106.8	111.5	208.9	157.3	125.2	160.3	222.1
1910.....	93.8	121.1	196.1	160.0	117.4	81.9	209.1
1911.....	80.9	104.2	153.9	137.2	106.3	121.8	241.5
1912.....	113.4	121.5	223.5	149.0	129.2	142.9	177.0
1913.....	90.4	110.6	235.8	134.7	118.4	127.3	242.0
1914.....	110.5	102.8	200.1	160.7	129.0	119.9	233.3
1915.....	96.3	87.1	224.7	132.1	132.8	103.9	234.1
1916.....	80.4		<sup>2</sup> 133.8			104.1	178.5
1917.....	100.8		<sup>2</sup> 204.3			115.2	235.2
1918.....	95.0		<sup>2</sup> 160.6			66.8	227.7
1919.....	87.9						

<sup>1</sup> Bushels of 60 pounds.

<sup>2</sup> Excluding Alsace-Lorraine.

## POTATOES.

TABLE 92.—Potatoes: Acreage, production, value, exports, etc., in the United States, 1849-1919.

NOTE.—Figures in *italics* are census returns; figures in roman are estimates of the Department of Agriculture. Estimates of acres are obtained by applying estimated percentages of increase or decrease to the published numbers of the preceding year, except that a revised base is used for applying percentage estimates whenever new census data are available.

Year.	Acreage.	Average yield per acre.	Production.	Average farm price per bushel Dec. 1.	Farm value Dec. 1.	Chicago cash price per bushel, fair to fancy. <sup>1</sup>				Domestic exports, fiscal year beginning July 1.	Imports during fiscal year beginning July 1.
						December.		Following May.			
						Low.	High.	Low.	High.		
1849			<i>65,798,000</i>							<i>155,595</i>	
1859			<i>111,149,000</i>							<i>380,372</i>	
1866	1,069,000	100.2	107,201,000	47.3	50,723,000					512,380	198,265
1867	1,192,000	82.0	97,783,000	65.9	64,462,000					378,005	209,555
1868	1,132,000	93.8	106,090,000	59.3	62,919,000					508,249	138,470
1869	1,222,000	109.5	133,886,000	42.9	57,481,000					596,968	75,336
1869			<i>143,337,000</i>								
1870	1,325,000	86.6	114,775,000	65.0	74,621,000					553,070	458,758
1871	1,221,000	98.7	120,462,000	53.9	64,905,000					621,537	96,259
1872	1,331,000	85.3	113,516,000	53.5	60,692,000					515,306	346,840
1873	1,295,000	81.9	106,089,000	65.2	69,154,000					497,413	549,073
1874	1,310,000	80.9	105,981,000	61.5	65,223,000					609,642	188,757
1875	1,510,000	110.5	166,877,000	34.4	57,358,000					704,379	92,148
1876	1,742,000	71.7	124,827,000	61.9	77,320,000					529,650	3,205,555
1877	1,792,000	94.9	170,092,000	43.7	74,272,000					744,409	528,584
1878	1,777,000	69.9	124,127,000	58.7	72,924,000					625,342	2,624,149
1879	1,837,000	98.9	181,626,000	43.6	79,154,000					696,080	721,868
1879			<i>169,459,000</i>								
1880	1,843,000	91.0	167,660,000	48.3	81,062,000					638,840	2,170,372
1881	2,042,000	53.5	109,145,000	91.0	99,291,000					408,286	8,789,860
1882	2,172,000	78.7	170,973,000	55.7	95,305,000					439,443	2,362,362
1883	2,280,000	90.9	208,164,000	42.2	87,849,000					554,613	425,408
1884	2,221,000	85.8	190,642,000	39.6	75,524,000					380,868	658,633
1885	2,266,000	77.2	175,029,000	44.7	78,153,000			33	50	494,948	1,937,416
1886	2,287,000	73.5	168,051,000	46.7	78,442,000	44	47	65	90	434,864	1,432,490
1887	2,357,000	56.9	134,103,000	68.2	91,507,000	70	83	65	85	403,880	8,259,538
1888	2,533,000	79.9	202,365,000	40.2	81,414,000	30	37	24	45	471,955	883,380
1889	2,648,000	77.4	204,881,000	35.4	72,611,000	33	45	30	60	406,618	3,415,578
1889			<i>217,545,000</i>								
1890	2,652,000	55.9	148,290,000	75.8	112,342,000	82	93	95	110	341,189	5,401,912
1891	2,715,000	93.7	254,424,000	35.8	91,013,000	30	40	30	50	557,022	186,871
1892	2,548,000	61.5	156,655,000	66.1	103,568,000	60	72	70	98	845,720	4,317,021
1893	2,605,000	70.3	183,034,000	59.4	108,662,000	51	60	64	88	803,111	3,002,578
1894	2,738,000	62.4	170,787,000	53.6	91,527,000	43	58	40	70	572,957	1,341,533
1895	2,955,000	100.6	297,237,000	26.6	78,985,000	18	24	10	23	680,049	175,240
1896	2,767,000	91.1	252,235,000	28.6	72,182,000	18	26	19	26	926,646	246,178
1897	2,535,000	64.7	164,016,000	54.7	89,643,000	50	62	60	87	605,187	1,171,378
1898	2,558,000	75.2	192,306,000	41.4	79,575,000	30	36	33	52	579,833	530,420
1899	2,581,000	88.6	228,783,000	39.0	89,329,000	35	46	27	39	809,472	155,861
1899			<i>2,939,000</i>								
1900	2,611,000	80.8	210,927,000	43.1	90,811,000	40	48	35	60	741,483	371,911
1901	2,864,000	65.5	187,598,000	76.7	143,979,000	75	82	58	100	528,484	7,656,162
1902	2,966,000	96.0	284,633,000	47.1	134,111,000	42	48	42	60	843,075	358,505
1903	2,917,000	84.7	247,128,000	61.4	151,638,000	60	66	95	116	484,042	3,161,581
1904	3,016,000	110.4	332,830,000	45.3	150,673,000	32	38	20	25	1,163,270	186,199
1905	2,997,000	87.0	260,741,000	61.7	160,821,000	55	66	48	73	1,000,326	1,948,100
1906	3,013,000	102.2	308,638,000	51.1	157,547,000	40	43	55	75	1,530,461	176,917
1907	3,128,000	95.4	298,262,000	61.8	184,184,000	46	58	50	80	1,203,894	403,952
1908	3,257,000	85.7	278,985,000	70.6	197,039,000	60	77	70	150	763,651	8,383,966
1909	3,525,000	106.8	376,537,000	54.1	210,662,000	20	58	16	34	999,476	353,208
1909			<i>3,669,000</i>								
1910 <sup>2</sup>	3,720,000	93.8	349,032,000	55.7	194,566,000	30	48	35	75	2,383,887	218,964
1911	3,619,000	80.9	292,737,000	79.9	233,778,000	70	100	90	200	1,237,276	13,734,695
1912	3,711,000	113.4	420,647,000	50.5	212,550,000	40	65	33	70	2,028,261	337,230
1913	3,668,000	90.4	331,525,000	68.7	227,903,000	50	70	60	90	1,794,073	3,645,993
1914	3,711,000	110.5	409,921,000	48.7	199,460,000	30	66	34	150	3,135,474	270,942
1915	3,734,000	96.3	359,721,000	61.7	221,992,000	53	95	80	110	4,017,760	209,532
1916	3,565,000	80.5	286,953,000	146.1	419,333,000	125	190	200	375	2,489,001	3,079,025
1917	4,384,000	100.8	442,108,000	122.8	542,774,000	93	135	80	250	3,453,307	1,180,480
1918	4,295,000	95.9	411,860,000	119.3	491,527,000	90	225	125	250	3,688,840	3,534,076
1919	4,013,000	89.2	357,901,000	161.4	577,581,000	280	360				

<sup>1</sup> Burbank to 1910.<sup>2</sup> Figures adjusted to census basis.<sup>3</sup> Per 100 pounds.

Statistics of Potatoes.

571

POTATOES—Continued.

TABLE 93.—Potatoes: Revised acreage, production, and farm value, 1889–1909.

NOTE.—This revision for 1879 and 1889–1909 consists (1) in using the Department of Agriculture's estimate of average yield per acre to compute, from census acreage, the total production, (2) in adjusting the department's estimate of acreage for each year so as to be consistent with the following as well as the preceding census acreage, and (3) in recomputing total farm value from these revised production figures.

Year.	Acreage.	Average yield per acre.	Production.	Average farm price per bushel Dec. 1.	Farm value Dec. 1.
	<i>Acres.</i>	<i>Bushels.</i>	<i>Bushels.</i>	<i>Cents.</i>	<i>Dollars.</i>
1889	2,691,000	77.4	201,200,000	35.4	71,294,000
1890	2,653,000	56.7	150,494,000	75.3	113,291,000
1891	2,732,000	93.7	256,122,000	35.6	91,229,000
1892	2,650,000	62.1	164,516,000	65.5	107,835,000
1893	2,722,000	71.7	195,040,000	58.4	113,886,000
1894	2,891,000	63.6	183,841,000	52.8	97,030,000
1895	3,101,000	102.3	317,114,000	26.2	83,151,000
1896	2,975,000	91.4	271,769,000	29.0	78,783,000
1897	2,813,000	67.9	191,025,000	54.2	103,442,000
1898	2,841,000	77.0	218,772,000	41.5	90,897,000
1899	2,939,000	88.6	260,257,000	39.7	103,365,000
1900	2,987,000	82.9	247,759,000	42.3	104,764,000
1901	2,996,000	66.3	198,626,000	76.3	151,602,000
1902	3,078,000	95.5	293,918,000	46.9	137,730,000
1903	3,080,000	85.1	262,053,000	60.9	159,620,000
1904	3,172,000	111.1	352,268,000	44.8	157,646,000
1905	3,195,000	87.3	278,885,000	61.1	170,340,000
1906	3,244,000	102.2	331,685,000	50.6	167,795,000
1907	3,375,000	95.7	322,954,000	61.3	197,863,000
1908	3,503,000	86.2	302,000,000	69.7	210,618,000
1909	3,663,000	107.5	394,553,000	54.2	213,679,000

TABLE 94.—Potatoes: Acreage, production, and total farm value, by States, 1919.

[000 omitted.]

State.	Acreage.	Production.	Farm value Dec. 1.	State.	Acreage.	Production.	Farm value Dec. 1.
	<i>Acres.</i>	<i>Bushels.</i>	<i>Dollars.</i>		<i>Acres.</i>	<i>Bushels.</i>	<i>Dollars.</i>
Maine	102	24,480	34,272	North Dakota	90	5,670	9,072
New Hampshire	20	2,400	4,200	South Dakota	90	4,500	8,550
Vermont	25	3,125	4,906	Nebraska	115	6,325	12,018
Massachusetts	33	2,970	5,643	Kansas	68	5,168	9,819
Rhode Island	5	425	765	Kentucky	72	5,040	10,584
Connecticut	24	1,680	3,276	Tennessee	48	3,120	5,366
New York	363	39,567	57,372	Alabama	44	3,520	7,568
New Jersey	110	10,560	17,846	Mississippi	18	1,550	2,830
Pennsylvania	254	25,400	39,116	Louisiana	25	1,000	3,520
Delaware	11	913	1,141	Texas	52	3,796	7,972
Maryland	55	5,170	6,721	Oklahoma	44	3,520	7,216
Virginia	121	11,495	18,047	Arkansas	41	3,321	6,808
West Virginia	57	5,130	8,978	Montana	47	2,820	4,512
North Carolina	58	4,930	8,036	Wyoming	33	2,610	5,016
South Carolina	27	2,295	4,590	Colorado	92	11,040	18,768
Georgia	23	1,610	3,494	New Mexico	11	495	940
Florida	24	1,824	3,830	Arizona	5	350	682
Ohio	150	9,300	17,856	Utah	17	2,397	3,284
Indiana	100	4,400	8,580	Nevada	6	900	1,350
Illinois	155	8,060	15,798	Idaho	26	5,400	8,154
Michigan	326	28,688	38,729	Washington	58	7,250	10,512
Wisconsin	300	28,200	39,480	Oregon	45	4,230	6,345
Minnesota	300	26,100	39,933	California	88	11,352	19,412
Iowa	115	4,945	9,494				
Missouri	110	8,250	15,180	United States	4,013	357,991	577,581

## POTATOES—Continued.

TABLE 95.—Potatoes: Condition of crop, United States, on 1st of months named, 1898–1919.

Year.	July.	Aug.	Sept.	Oct.	Year.	July.	Aug.	Sept.	Oct.
	<i>P. ct.</i>	<i>P. ct.</i>	<i>P. ct.</i>	<i>P. ct.</i>		<i>P. ct.</i>	<i>P. ct.</i>	<i>P. ct.</i>	<i>P. ct.</i>
1898.....	95.5	83.9	77.7	72.5	1909.....	93.0	85.8	80.9	78.8
1899.....	93.8	93.0	86.3	81.7	1910.....	86.3	75.8	70.5	71.8
1900.....	91.3	88.2	80.0	74.4	1911.....	76.0	62.3	59.8	62.3
1901.....	87.4	62.3	52.2	54.0	1912.....	88.9	87.8	87.2	85.1
1902.....	92.9	94.8	89.1	82.5	1913.....	86.2	78.0	69.9	67.7
1903.....	88.1	87.2	84.3	74.6	1914.....	83.6	79.0	75.8	78.3
1904.....	93.9	94.1	91.6	89.5	1915.....	91.1	92.0	82.7	74.2
1905.....	91.2	87.2	80.9	74.3	1916.....	87.8	80.8	67.4	62.6
1906.....	91.5	89.0	85.3	82.2	1917.....	90.1	87.9	82.7	79.0
1907.....	90.2	88.5	80.2	77.0	1918.....	87.6	79.9	74.5	73.7
1908.....	89.6	82.9	73.7	68.7	1919.....	87.6	75.1	69.5	67.9

TABLE 96.—Potatoes: Yield per acre, price per bushel Dec. 1, and value per acre, by States.

State.	Yield per acre (bushels).											Farm price per bushel (cents).					Value per acre (dollars). <sup>1</sup>		
	10-year aver- age, 1910-1919.	1910	1911	1912	1913	1914	1915	1916	1917	1918	1919	10-year aver- age, 1910-1919.	1915	1916	1917	1918	1919	5-year aver- age, 1914-1918.	1919
Mo.....	203	220	180	198	220	260	179	204	125	200	240	86	70	142	130	120	140	180.66	336.00
N. H.....	128	150	125	140	122	159	95	120	107	140	120	109	95	166	167	145	175	153.31	210.00
Vt.....	124	130	105	140	127	168	108	112	100	130	125	95	81	139	140	138	157	128.30	196.25
Mass.....	116	125	93	130	105	155	120	91	115	133	90	120	94	175	175	170	190	161.89	171.00
R. I.....	119	136	110	113	130	165	110	74	135	130	85	122	92	185	175	173	180	162.95	153.00
Conn.....	101	125	85	107	92	140	95	95	110	95	70	120	96	175	164	165	195	137.12	136.50
N. Y.....	94	102	74	106	74	145	62	70	95	98	109	96	82	158	130	122	145	93.66	158.05
N. J.....	104	105	73	108	95	108	130	122	114	92	96	109	75	155	141	170	169	133.92	162.24
Pa.....	86	88	56	109	88	105	72	70	92	80	100	100	75	148	135	151	154	92.70	154.00
Del.....	88	103	60	100	87	80	95	90	95	87	83	97	75	125	130	140	125	97.01	103.75
Md.....	88	95	45	112	87	78	97	95	100	80	94	89	62	133	119	120	130	89.66	122.20
Va.....	93	98	45	87	94	65	125	130	99	94	95	98	61	137	125	120	157	108.19	149.15
W. Va.....	88	92	45	112	83	54	117	88	115	87	90	109	65	158	132	160	175	109.97	157.50
N. C.....	81	89	48	85	80	52	90	95	90	95	85	108	73	140	143	135	163	100.70	138.55
S. C.....	84	90	70	90	80	70	80	75	96	102	85	149	115	175	210	193	200	141.84	170.00
Ga.....	72	82	72	78	81	60	65	60	84	70	70	138	99	175	195	185	217	105.13	151.90
Fla.....	85	90	90	93	76	80	80	74	91	100	76	152	115	200	205	200	210	143.39	159.60
Ohio.....	78	82	65	112	64	95	82	45	100	69	62	106	70	182	143	150	192	87.23	119.04
Ind.....	74	84	58	114	53	80	95	44	92	80	44	103	56	177	139	135	195	82.35	85.80
Ill.....	71	75	50	101	46	60	110	58	90	72	52	109	59	179	152	148	196	89.74	101.92
Mich.....	90	105	94	105	96	121	59	48	95	84	88	77	56	160	105	89	135	64.12	118.80
Wis.....	102	95	116	120	109	124	87	47	114	110	94	72	45	147	90	80	140	67.21	131.60
Minn.....	100	61	115	135	110	114	106	60	112	105	87	72	39	130	91	75	153	67.30	133.11
Iowa.....	75	72	74	109	48	86	105	42	95	72	43	100	54	175	131	133	192	80.23	82.56
Mo.....	66	86	27	84	38	45	98	60	87	61	75	112	60	180	137	153	184	82.43	138.00
N. Dak.....	87	41	120	128	85	109	90	93	43	99	63	79	41	115	130	73	160	63.56	100.80
S. Dak.....	80	44	72	105	78	90	115	66	90	91	50	87	35	137	111	93	190	71.50	95.00
Nebr.....	72	60	52	80	48	80	105	73	85	86	55	97	42	150	107	118	190	77.85	104.50
Kans.....	60	57	22	82	40	62	83	71	57	53	76	116	74	165	152	144	190	77.85	144.40
Ky.....	78	92	39	101	49	45	126	84	96	75	70	113	55	142	140	165	210	96.91	147.00
Tenn.....	72	80	41	88	64	43	88	82	94	70	65	111	63	149	126	165	172	90.14	111.80
Ala.....	80	80	78	81	84	79	80	90	72	80	80	134	90	169	182	181	215	115.95	172.00
Miss.....	82	85	83	89	80	80	90	65	78	80	85	126	84	160	168	165	185	103.73	157.25
La.....	66	55	69	73	70	70	51	65	64	79	64	128	95	167	184	150	220	92.23	140.80
Tex.....	59	51	57	63	52	61	65	50	60	55	73	147	105	190	210	200	210	92.54	153.30
Okla.....	59	60	18	60	60	70	85	53	69	34	80	137	84	195	180	195	205	85.65	164.00
Ark.....	71	84	55	70	72	60	90	65	80	50	81	130	76	190	157	184	205	93.54	166.05
Mont.....	128	120	150	165	140	140	155	125	95	135	60	84	50	120	102	80	160	104.40	96.00
Wyo.....	120	100	42	140	140	108	150	130	155	150	80	98	60	128	104	85	190	124.14	152.00
Colo.....	118	100	35	95	115	120	135	138	160	160	120	86	55	135	91	99	170	124.91	204.00
N. Mex.....	86	47	80	100	68	100	100	102	116	100	45	129	95	175	165	160	190	143.98	85.50
Ariz.....	97	92	95	125	75	110	95	115	105	85	70	148	100	180	150	205	195	153.15	136.50
Utah.....	160	142	140	185	180	140	125	180	189	180	141	82	63	130	78	97	137	143.75	193.17
Nev.....	167	150	160	178	160	130	172	190	207	171	150	96	70	130	120	123	150	183.43	225.00
Idaho.....	160	142	180	185	170	155	125	150	156	185	150	75	56	127	79	81	151	121.60	226.50
Wash.....	139	131	160	167	123	128	135	165	125	132	125	78	53	98	92	101	145	110.39	181.25
Oreg.....	120	105	130	155	135	97	115	150	108	110	94	77	60	90	80	100	150	91.72	141.00
Calif.....	134	130	135	130	119	138	130	141	145	143	129	104	75	140	150	120	171	156.12	220.59
U. S.....	95.2	93.8	80.9	113.4	90.4	110.5	96.3	80.5	100.8	95.9	89.2	91.5	61.7	146.1	122.8	119.3	161.4	93.81	143.93

<sup>1</sup> Based upon farm price Dec. 1.

POTATOES—Continued.

TABLE 97.—Potatoes: Stocks on January 1.

State and year.	Total production (000 omitted).	Stocks Jan. 1.				Price per bushel.	
		Per cent of crop.	Bushels (000 omitted).	Per cent of stock held by—		Dec. 1.	Mar. 1.
				Growers.	Dealers.		
<b>Total (21 Northern States):</b>	<i>Bush.</i>					<i>Cts.</i>	<i>Cts.</i>
1919-20.....	250,213	36.4	90,972	79.5	20.5	157	.....
1918-19.....	281,060	43.5	122,261	82.4	17.6	115	102
1917-18.....	303,899	49.6	150,666	84.6	15.4	122	116
1916-17.....	183,281	33.1	60,603	74.9	25.1	152	252
<b>Total (11 far West States):</b>							
1919-20.....	48,874	43.1	21,063	71.6	28.4	162	.....
1918-19.....	66,630	48.0	31,982	85.3	14.7	101	89
1917-18.....	70,779	42.0	32,748	86.8	13.2	105	88
1916-17.....	54,081	44.6	24,140	71.0	29.0	120	238
<b>Total (16 Southern States):</b>							
1919-20.....	58,814	27.5	16,146	69.1	30.9	181	.....
1918-19.....	64,170	32.3	20,730	79.5	20.5	157	161
1917-18.....	67,430	31.0	20,900	82.8	17.2	147	171
1916-17.....	49,591	16.3	8,065	68.8	31.2	151	204
<b>Maine:</b>							
1919-20.....	24,480	55.0	13,464	78.0	22.0	140	.....
1918-19.....	22,400	54.0	12,096	81.0	19.0	120	85
1917-18.....	18,750	55.0	10,313	84.0	16.0	130	135
1916-17.....	25,500	47.0	11,985	72.0	28.0	142	260
<b>New York:</b>							
1919-20.....	39,567	48.0	18,992	90.0	10.0	145	.....
1918-19.....	37,240	50.0	18,620	92.0	8.0	122	105
1917-18.....	38,000	58.0	22,040	95.0	5.0	130	120
1916-17.....	22,400	41.0	9,184	85.0	15.0	158	275
<b>Pennsylvania:</b>							
1919-20.....	25,400	30.0	7,620	80.0	20.0	154	.....
1918-19.....	22,000	42.0	9,240	88.0	12.0	151	126
1917-18.....	29,532	43.0	12,699	88.0	12.0	135	131
1916-17.....	19,040	32.0	6,092	81.0	19.0	148	264
<b>Ohio:</b>							
1919-20.....	9,300	34.0	3,162	71.0	29.0	192	.....
1918-19.....	11,040	39.0	4,306	74.0	26.0	150	139
1917-18.....	16,000	53.0	8,480	87.0	13.0	143	134
1916-17.....	6,300	21.0	1,323	71.0	29.0	182	286
<b>Indiana:</b>							
1919-20.....	4,400	27.0	1,188	70.0	30.0	195	.....
1918-19.....	8,640	48.0	4,147	81.0	19.0	135	129
1917-18.....	8,464	47.0	3,978	81.0	19.0	139	138
1916-17.....	3,256	20.0	652	85.0	15.0	177	272
<b>Illinois:</b>							
1919-20.....	8,060	29.0	2,337	76.0	24.0	196	.....
1918-19.....	11,520	34.0	3,917	74.0	26.0	148	138
1917-18.....	13,500	40.0	5,400	88.0	12.0	152	153
1916-17.....	7,250	27.0	1,958	74.0	26.0	179	270
<b>Michigan:</b>							
1919-20.....	28,688	35.0	10,041	77.0	23.0	135	.....
1918-19.....	28,560	51.0	14,566	82.0	18.0	89	77
1917-18.....	35,910	58.0	20,828	88.0	12.0	105	85
1916-17.....	15,360	36.0	5,530	78.0	22.0	160	235
<b>Wisconsin:</b>							
1919-20.....	28,200	36.0	10,152	78.0	22.0	140	.....
1918-19.....	33,440	51.0	17,054	80.0	20.0	80	76
1917-18.....	34,998	60.0	20,999	80.0	20.0	90	83
1916-17.....	13,630	56.0	7,633	79.0	21.0	147	227
<b>Minnesota:</b>							
1919-20.....	26,100	33.0	8,613	76.0	24.0	153	.....
1918-19.....	32,760	42.0	13,759	76.0	24.0	75	63
1917-18.....	33,600	50.0	16,800	80.0	20.0	91	75
1916-17.....	16,800	37.0	6,216	62.0	38.0	130	210
<b>North Dakota:</b>							
1919-20.....	5,670	21.0	1,191	86.0	14.0	160	.....
1918-19.....	9,108	42.0	3,825	86.0	14.0	73	83
1917-18.....	3,870	29.0	1,122	86.0	14.0	130	140
1916-17.....	6,975	22.0	1,534	63.0	37.0	115	173
<b>Nebraska:</b>							
1919-20.....	6,325	36.0	2,277	78.0	22.0	190	.....
1918-19.....	10,406	37.0	3,850	76.0	24.0	118	135
1917-18.....	12,495	48.0	5,998	79.0	21.0	107	126
1916-17.....	7,665	29.0	2,223	69.0	31.0	150	228
<b>Kentucky:</b>							
1919-20.....	5,040	41.0	2,066	61.0	39.0	210	.....
1918-19.....	5,825	52.0	2,925	75.0	25.0	165	151
1917-18.....	6,720	53.0	3,562	83.0	17.0	140	156
1916-17.....	4,116	36.0	1,482	89.0	11.0	142	235

## POTATOES—Continued.

TABLE 97.—Potatoes: Stocks on January 1—Continued.

State and year.	Total production (000 omitted).	Stocks Jan. 1.				Price per bushel.	
		Per cent of crop.	Bushels (000 omitted).	Per cent of stock held by—		Dec. 1.	Mar. 1.
				Growers.	Dealers.		
<b>Montana:</b>							
1919-20.....	2,820					160	
1918-19.....	6,750	66.0	4,455	82.0	18.0	82	110
1917-18.....	5,415	45.0	2,437	84.0	16.0	102	104
1916-17.....	4,875	64.0	3,120	63.0	37.0	120	163
<b>Colorado:</b>							
1919-20.....	11,040	38.0	4,195	89.0	11.0	170	
1918-19.....	15,840	56.0	8,870	89.0	11.0	99	66
1917-18.....	12,800	60.0	7,680	90.0	10.0	91	91
1916-17.....	6,900	42.0	2,898	86.0	14.0	135	238
<b>Idaho:</b>							
1919-20.....	5,400	41.0	2,214	63.0	37.0	151	
1918-19.....	6,290	58.0	3,648	86.0	14.0	81	59
1917-18.....	6,084	46.0	2,799	87.0	13.0	79	65
1916-17.....	4,050	44.0	1,782	84.0	16.0	127	175
<b>Washington:</b>							
1919-20.....	7,250	55.0	3,988	75.0	25.0	145	
1918-19.....	8,316	62.0	5,156	89.0	11.0	101	75
1917-18.....	9,875	36.0	3,555	83.0	17.0	92	62
1916-17.....	9,900	32.0	3,168	69.0	31.0	98	168

TABLE 98.—Potatoes: Farm price, cents per bushel on first of each month, 1910-1919.

Date.	1919	1918	1917	1916	1915	1914	1913	1912	1911	1910	Average.
Jan. 1.....	116.1	121.0	147.3	70.6	49.7	68.4	50.6	84.5	54.1	56.0	81.8
Feb. 1.....	114.4	122.9	172.4	88.0	50.4	69.7	53.1	94.4	55.1	56.2	87.7
Mar. 1.....	109.4	120.3	240.7	94.4	50.4	70.7	52.0	102.0	55.3	54.6	95.0
Apr. 1.....	105.4	92.6	234.7	97.6	47.8	70.0	50.3	117.1	55.5	47.4	91.8
May 1.....	118.9	80.1	279.6	94.8	50.5	71.4	48.2	127.3	62.5	38.4	97.2
June 1.....	121.4	75.5	274.0	98.8	50.8	71.3	55.2	119.7	63.3	37.4	96.7
July 1.....	128.4	94.9	247.9	102.3	52.1	81.5	49.8	103.6	96.3	40.1	99.7
Aug. 1.....	192.8	141.6	170.8	95.4	56.3	87.1	69.2	86.5	136.0	64.9	110.1
Sept. 1.....	187.5	148.8	139.1	109.3	50.5	74.9	75.3	65.0	113.7	72.9	103.7
Oct. 1.....	164.2	143.6	122.1	112.0	48.8	64.7	73.9	51.1	88.3	67.8	93.6
Nov. 1.....	152.8	127.2	127.8	135.7	60.8	52.8	69.6	45.5	76.3	55.7	90.4
Dec. 1.....	161.4	119.3	122.8	146.1	61.7	48.7	68.7	50.5	79.9	55.7	91.5
Average.....	148.4	121.8	164.9	114.1	54.4	64.4	64.3	72.5	80.6	56.4	94.2

TABLE 99.—Late commercial potato crop.

The States in the following table include all those State producing late potatoes in considerable commercial quantity for other than local market.

State.	Average yield per acre, 1919.	Estimated commercial production.		1919 as per cent of 1918.	Per cent of crop in hands of growers Dec. 1, 1919.	Per cent lost after harvest, 1919.
		1919	1918			
	<i>Bushels.</i>	<i>Carloads.<sup>1</sup></i>	<i>Carloads.<sup>1</sup></i>	<i>Per cent.</i>	<i>Per cent.</i>	<i>Per cent.</i>
Maine.....	260	27,499	26,922	102	65	9.0
New York.....	122	11,500	10,650	108	42	4.5
Pennsylvania.....	121	6,600	5,950	111	36	11.0
Michigan.....	95	10,460	12,000	87	44	2.3
Wisconsin.....	98	20,900	25,510	82	34	5.8
Minnesota.....	93	25,105	28,000	97	28	6.0
Iowa.....	73	229	950	24	20	2.0
North Dakota.....	63	2,000	2,950	68	11	5.0
Nebraska.....	69	2,211	5,000	44	33	12.0
Montana.....	107	450	946	48	25	10.0
Colorado.....	155	10,000	14,800	68	31	0.0
Utah.....	159	450	490	92	14	2.0
Nevada.....	160	790	725	109	15	2.0
Idaho.....	170	6,830	7,725	88	28	5.5
Washington.....	120	2,400	3,130	77	18	5.0
Oregon.....	191	1,200	2,350	51	62	5.0
California.....	170	4,599	6,200	73	17	( <sup>2</sup> )
United States.....	144	133,124	152,298	87	39	5.8

<sup>1</sup> Carload figures are based on cars loaded 700 bushels.<sup>2</sup> Not reported.



TABLE 100.—Potatoes: Wholesale price, 1913-1919.

Date.	New York State and Western (per 180 pounds).			Chicago, fair to fancy (per bushel).			Minneapolis (per bushel).			St. Louis, Burbank (per bushel).			Cincinnati (per bushel).			Denver (per 100 pounds).			San Francisco (per 100 pounds).			
	Low.	High.	Average.	Low.	High.	Average.	Low.	High.	Average.	Low.	High.	Average.	Low.	High.	Average.	Low.	High.	Average.	Low.	High.	Average.	
1913.																						
January-June	\$1.70	\$2.87	.....	\$0.15	\$0.70	.....	\$0.33	\$0.60	.....	\$0.30	\$0.87	.....	\$0.30	\$1.00	.....	\$0.50	\$4.00	.....	\$0.20	\$1.65	.....	
July-December	1.75	2.37	.....	.50	.82	.....	.50	1.00	.....	.45	.93	.....	.65	1.00	.....	.60	2.50	.....	.50	1.25	.....	
1914.																						
January-June	2.00	3.00	.....	.56	1.75	.....	.55	1.35	.....	.65	1.60	.....	.65	1.15	.....	1.00	2.50	.....	.80	1.65	.....	
July-December	1.25	2.12	.....	.28	1.65	.....	.28	1.50	.....	.33	1.50	.....	.45	1.70	.....	.90	2.75	.....	.60	1.30	.....	
1915.																						
January-June	1.00	1.75	.....	.18	1.50	.....	.30	.65	.....	.38	.55	.....	.30	.50	.....	.90	2.25	.....	1.00	3.50	.....	
July-December	1.75	3.00	.....	.17	.95	.....	.25	1.00	.....	.22	.96	.....	.30	.90	.....	.85	2.25	.....	.85	1.50	.....	
1916.																						
January-June	2.85	3.90	.....	.60	1.30	.....	.62	1.35	.....	.73	1.35	.....	.65	1.30	.....	1.40	5.00	.....	.90	2.25	.....	
July-December	3.40	5.25	.....	.65	2.00	.....	.75	1.75	.....	.50	2.10	.....	.80	1.90	.....	1.65	3.25	.....	1.00	2.50	.....	
1917.																						
January-June	4.75	11.00	.....	1.00	4.50	.....	1.50	4.20	.....	1.70	3.35	.....	1.85	3.90	.....	2.25	6.50	.....	1.90	5.00	.....	
July-December	3.00	5.75	.....	.90	2.85	.....	.90	2.75	.....	.87	1.70	.....	1.10	2.75	.....	2.00	4.25	.....	1.25	2.75	.....	
1918.	<i>Per 100 pounds.</i>			<i>Per 100 pounds.</i>			<i>Per 100 pounds.</i>			<i>Per 100 pounds.</i>			<i>Per 100 pounds.</i>									
January-June	1.00	3.33	\$2.02	.45	3.50	\$1.69	.80	3.25	\$1.64	.80	2.45	\$1.57	.....	.....	.....	.75	3.25	\$2.05	1.00	2.00	\$1.37	
July-December	1.65	2.40	2.15	.85	3.25	2.01	1.50	3.25	2.08	1.07	2.85	1.41	.....	.....	.....	1.00	3.65	2.85	1.25	2.75	2.00	
1919.																						
January	3.50	5.75	4.52	.95	2.50	1.90	1.50	1.90	1.66	1.85	2.30	2.02	1.25	2.50	\$2.09	1.40	2.00	1.70	1.50	2.00	1.71	
February	3.25	5.00	4.16	.90	2.00	1.58	1.55	1.65	1.60	1.60	2.00	1.73	1.75	2.35	2.03	1.40	2.00	1.70	1.50	2.00	1.77	
March	3.00	4.75	3.83	.85	2.15	1.58	1.40	1.50	1.44	1.25	2.25	1.82	1.75	2.35	2.04	1.40	2.00	1.70	1.75	2.50	1.89	
April	3.00	6.00	4.55	.95	2.50	1.79	1.60	2.15	1.88	1.65	2.65	2.22	1.90	3.50	2.42	1.40	2.00	1.70	1.80	3.00	2.38	
May	3.25	6.00	4.96	1.25	2.50	1.93	1.80	4.00	2.47	1.80	2.50	2.33	2.25	3.00	2.55	1.40	7.00	3.84	1.90	2.75	2.11	
June	3.50	5.50	4.50	1.25	3.25	1.52	.....	.....	.....	1.75	2.50	2.23	2.00	2.40	2.16	1.50	7.00	3.67	1.90	2.30	2.10	
January-June	3.00	6.00	4.42	.85	3.25	1.72	1.40	4.00	1.81	1.25	2.65	2.06	1.25	3.50	2.22	1.40	7.00	2.38	1.50	3.00	1.99	
July	1.00	7.25	3.61	2.50	4.75	3.54	3.25	4.50	3.67	1.50	3.40	2.73	4.00	7.50	5.91	1.50	5.00	2.88	1.75	2.30	2.18	
August	.....	.....	.....	2.10	5.50	3.65	3.50	3.75	3.67	1.70	4.50	3.15	3.50	7.00	5.17	1.50	5.00	3.04	1.90	2.50	2.18	
September	4.00	5.25	5.13	1.90	3.65	2.72	2.20	2.45	2.32	2.00	3.50	2.87	3.50	7.00	5.60	2.25	3.00	2.65	1.90	2.25	2.00	
October	2.00	2.50	2.12	1.50	2.90	2.37	2.30	2.75	2.45	1.50	3.25	2.52	6.50	7.50	7.00	2.15	3.00	2.49	2.00	2.50	2.17	
November	2.00	3.00	2.61	2.10	3.70	2.86	2.40	2.50	2.45	2.15	3.30	2.86	2.65	4.75	3.53	3.00	3.75	3.39	2.25	3.00	2.65	
December	2.00	3.33	2.85	2.80	3.60	3.19	2.70	3.15	2.89	2.15	4.00	3.27	4.50	5.75	4.92	3.10	4.00	3.45	2.25	4.25	3.02	
July-December	1.00	7.25	3.26	1.50	5.50	3.06	2.20	4.50	2.91	1.50	4.50	2.90	2.65	7.50	5.36	1.50	5.00	2.98	1.75	4.25	2.37	

Statistics of Potatoes.

## POTATOES—Continued.

TABLE 101.—Potatoes: International trade, calendar years, 1911-13, 1917, and 1918.

GENERAL NOTE.—Substantially the international trade of the world. It should not be expected that the world export and import totals for any year will agree. Among sources of disagreement are these: (1) Different periods of time covered in the "year" of the various countries; (2) imports received in year subsequent to year of export; (3) want of uniformity in classification of goods among countries; (4) different practices and varying degrees of failure in recording countries of origin and ultimate destination; (5) different practices of recording reexported goods; (6) opposite methods of treating free ports; (7) clerical errors, which, it may be assumed, are not infrequent.

The exports given are domestic exports, and the imports given are imports for consumption as far as it is feasible and consistent so to express the facts. While there are some inevitable omissions, on the other hand there are some duplications because of reshipments that do not appear as such in official reports. For the United Kingdom, import figures refer to imports for consumption, when available, otherwise total imports, less exports, of "foreign and colonial merchandise." Figures for the United States include Alaska, Porto Rico, and Hawaii.

## EXPORTS.

[000 omitted.]

Country.	Average, 1911-1913.	1917 (prelim.).	1918 (prelim.).	Country.	Average, 1911-1913.	1917 (prelim.).	1918 (prelim.).
<i>From—</i>	<i>Bushels.</i>	<i>Bushels.</i>	<i>Bushels.</i>	<i>From—</i>	<i>Bushels.</i>	<i>Bushels.</i>	<i>Bushels.</i>
Argentina.....	543	542	572	Netherlands.....	16,451		
Austria-Hungary.....	1,451			Portugal.....	500		
Belgium.....	8,692			Russia.....	7,762		
Canada.....	1,207	4,039	2,126	Spain.....	1,835	1,185	363
China.....	288	242	128	United Kingdom...	6,246	339	2,532
Denmark.....	928	31	1,703	United States.....	1,814	2,423	3,853
France.....	8,683	1,099	611	Other countries....	1,924		
Germany.....	12,412			Total.....	75,151		
Italy.....	3,975	583	148				
Japan.....	440	385	326				

## IMPORTS.

<i>Into—</i>				<i>Into—</i>			
Algeria.....	1,218	573	373	Norway.....	215	3,658	
Argentina.....	1,337	249	35	Philippine Islands..	334	287	239
Austria-Hungary.....	4,070			Portugal.....	273		
Belgium.....	4,921			Russia.....	309		
Brazil.....	939	43		Sweden.....	700	112	
Canada.....	525	463	683	Switzerland.....	3,172	1,259	140
Cuba.....	2,001	2,467	3,378	United Kingdom...	11,382	2,985	1,896
Egypt.....	599	359	297	United States.....	5,707	3,182	1,201
Finland.....	479			Other countries....	2,311		
France.....	7,143	970	1,069	Total.....	78,767		
Germany.....	29,180						
Netherlands.....	1,952						

SWEET POTATOES.

TABLE 102.—Sweet potatoes: Acreage, production, and value, in the United States, 1849-1919.

NOTE.—Figures in *italics* are census returns; figures in roman are estimates of the Department of Agriculture. Estimates of acres are obtained by applying estimated percentages of increase or decrease to the published numbers of the preceding year, except that a revised base is used for applying percentage estimates whenever new census data are available.

Year.	Acreage.	Average yield per acre.	Production.	Average farm price per bushel Dec. 1.	Farm value Dec. 1.
	<i>Acres.</i>	<i>Bushels.</i>	<i>Bushels.</i>	<i>Cents.</i>	<i>Dollars.</i>
1849.....			<i>38,268,000</i>		
1859.....			<i>42,095,000</i>		
1869.....			<i>21,710,000</i>		
1879.....			<i>33,379,000</i>		
1889.....			<i>43,950,000</i>		
1899.....	537,000	79.1	42,517,000	52.9	22,476,000
1900.....	544,000	88.9	48,346,000	50.6	24,478,000
1901.....	547,000	81.7	44,697,000	57.5	25,720,000
1902.....	532,000	85.2	45,344,000	58.1	26,358,000
1903.....	548,000	89.2	48,870,000	58.3	28,478,000
1904.....	548,000	88.9	48,705,000	60.4	29,424,000
1905.....	551,000	92.6	51,034,000	58.3	29,734,000
1906.....	554,000	90.2	49,948,000	62.2	31,063,000
1907.....	565,000	88.2	49,813,000	70.0	34,858,000
1908.....	599,000	92.4	55,352,000	66.1	36,564,000
1909.....	641,000	92.4	59,232,000	69.4	41,052,000
1910.....	641,000	93.5	59,938,000	67.1	40,216,000
1911.....	605,000	90.1	54,538,000	75.5	41,202,000
1912.....	583,000	95.2	55,479,000	72.6	40,264,000
1913.....	625,000	94.5	59,057,000	72.6	42,884,000
1914.....	603,000	93.8	56,574,000	73.0	41,294,000
1915.....	731,000	103.5	75,639,000	62.1	46,980,000
1916.....	774,000	91.7	70,955,000	84.8	60,141,000
1917.....	919,000	91.2	83,822,000	110.8	92,916,000
1918.....	940,000	93.5	87,924,000	135.2	118,863,000
1919.....	1,029,000	100.7	103,579,000	133.3	138,085,000

TABLE 103.—Sweet potatoes: Acreage, production, and total farm value, by States, 1919.

[000 omitted.]

State.	Acreage.	Production.	Farm value Dec. 1.	State.	Acreage.	Production.	Farm value Dec. 1.
	<i>Acres.</i>	<i>Bushels.</i>	<i>Dollars.</i>		<i>Acres.</i>	<i>Bushels.</i>	<i>Dollars.</i>
New Jersey.....	14	1,750	3,850	Kansas.....	4	436	807
Pennsylvania.....	1	138	248	Kentucky.....	16	1,680	2,688
Delaware.....	7	966	1,063	Tennessee.....	40	4,400	5,148
Maryland.....	12	1,680	2,234	Alabama.....	151	14,194	16,039
Virginia.....	38	4,750	7,362	Mississippi.....	98	10,290	11,525
West Virginia.....	2	230	483	Louisiana.....	70	6,300	7,245
North Carolina.....	106	9,858	13,604	Texas.....	95	10,450	15,675
South Carolina.....	84	7,560	11,189	Oklahoma.....	25	3,000	5,400
Georgia.....	142	13,064	14,370	Arkansas.....	46	4,600	5,290
Florida.....	41	4,100	5,740	New Mexico.....	3	450	1,012
Ohio.....	1	115	247	Arizona.....	1	150	375
Indiana.....	3	315	677	California.....	8	1,096	1,962
Illinois.....	9	855	1,496	United States..	1,029	103,579	138,085
Iowa.....	4	320	800				
Missouri.....	8	832	1,556				

SWEET POTATOES—Continued.

TABLE 104.—Sweet potatoes: Condition of crop, United States, on 1st of months named, 1899-1919.

Year.	July.	Aug.	Sept.	Oct.	Year.	July.	Aug.	Sept.	Oct.	Year.	July.	Aug.	Sept.	Oct.
	<i>P. ct.</i>	<i>P. ct.</i>	<i>P. ct.</i>	<i>P. ct.</i>		<i>P. ct.</i>	<i>P. ct.</i>	<i>P. ct.</i>	<i>P. ct.</i>		<i>P. ct.</i>	<i>P. ct.</i>	<i>P. ct.</i>	<i>P. ct.</i>
1899.....	85.1	84.1	80.7	74.9	1906.....	90.9	91.2	88.7	86.0	1913.....	86.5	85.8	81.4	80.1
1900.....	93.7	92.2	83.6	80.0	1907.....	85.9	85.7	85.7	82.7	1914.....	77.1	75.5	81.8	80.7
1901.....	93.1	80.7	78.7	79.0	1908.....	89.8	88.8	88.7	85.5	1915.....	88.7	85.5	87.5	85.0
1902.....	83.6	78.3	77.2	79.7	1909.....	89.7	86.9	81.3	77.8	1916.....	90.4	85.9	82.7	79.2
1903.....	90.2	88.7	91.1	83.7	1910.....	87.3	85.4	83.9	80.2	1917.....	81.9	84.8	85.7	83.2
1904.....	87.3	88.5	89.9	86.1	1911.....	78.4	77.7	79.1	78.1	1918.....	86.4	78.3	74.5	77.4
1905.....	90.6	90.1	89.5	88.6	1912.....	86.9	85.0	84.1	82.0	1919.....	90.1	87.1	86.0	83.9

TABLE 105.—Sweet potatoes: Yield per acre, price per bushel Dec. 1, and value per acre, by States.

State.	Yield per acre (bushels).											Farm price per bushel (cents).					Value per acre (dollars). <sup>1</sup>		
	10-year average, 1910-1919.											10-year average, 1910-1919.					5-year average, 1914-1918.		
	1910	1911	1912	1913	1914	1915	1916	1917	1918	1919	1915	1916	1917	1918	1919	1919	1919		
N. J.....	124	140	130	120	138	100	155	100	120	115	125	118	70	120	160	190	220	146.80	275.00
Pa.....	113	105	121	120	110	105	105	100	110	120	138	115	75	135	140	185	180	136.01	248.40
Del.....	123	115	110	120	135	120	135	125	112	120	138	82	62	81	120	125	110	110.67	151.80
Md.....	126	110	115	125	141	125	130	126	118	130	140	87	70	88	100	150	133	120.48	186.20
Va.....	107	100	90	90	108	92	110	130	104	120	125	92	65	90	110	145	155	109.36	193.75
W. Va.....	112	101	110	115	91	92	110	140	140	106	115	125	92	126	140	204	210	156.00	241.50
N. C.....	98	105	86	90	100	90	105	107	95	110	93	81	56	75	105	132	138	88.50	128.34
S. C.....	93	91	84	105	92	85	105	86	95	95	90	89	65	85	104	142	148	86.91	133.20
Ga.....	87	83	81	90	87	85	85	80	93	92	92	82	61	81	105	125	110	77.59	101.20
Fla.....	108	108	108	112	110	120	112	100	95	110	100	92	68	86	115	125	140	100.98	140.00
Ohio.....	103	98	113	118	90	110	95	99	95	96	115	129	98	150	175	175	215	136.29	247.75
Ind.....	104	104	114	116	78	100	104	100	106	108	105	128	90	150	165	195	215	143.82	225.75
Ill.....	92	110	89	98	70	84	110	90	97	82	95	120	82	125	150	175	175	114.30	166.25
Iowa.....	92	98	105	90	80	100	95	91	90	93	80	157	108	192	210	210	250	157.72	200.00
Mo.....	90	102	91	88	56	84	100	70	112	91	104	123	82	150	141	186	187	118.96	194.48
Kans.....	92	101	75	99	50	110	110	92	92	80	109	137	100	150	160	222	185	137.88	201.65
Ky.....	94	85	96	90	75	105	105	90	95	95	105	105	70	100	125	175	160	105.87	168.00
Tenn.....	95	85	85	90	80	100	105	100	95	98	110	87	59	87	105	136	117	90.20	128.70
Ala.....	91	85	97	100	95	93	90	74	90	96	94	79	57	74	92	115	113	71.94	106.22
Miss.....	92	94	85	97	98	90	110	82	65	95	105	74	55	67	97	104	112	66.80	117.60
La.....	86	93	90	84	85	87	92	90	79	75	90	79	50	66	104	128	115	67.85	103.50
Tex.....	82	56	71	75	80	101	98	89	78	58	110	112	70	90	140	175	150	89.45	165.00
Okla.....	87	70	75	92	64	102	115	73	90	65	120	130	73	135	160	220	180	112.33	216.00
Ark.....	98	98	92	88	90	95	130	91	110	90	100	90	61	90	96	138	115	92.83	115.00
N. Mex.....	134	100	150	141	125	143	160	125	118	125	150	159	120	180	205	250	225	226.60	337.50
Ariz.....	154	120	200	140	135	200	150	160	150	135	150	182	150	185	227	238	250	296.58	375.00
Calif.....	156	160	140	156	170	161	135	160	167	170	137	114	80	100	150	150	179	182.71	245.23
U. S.....	94.8	93.5	90.1	95.2	94.5	93.8	103.5	91.7	91.2	93.5	100.7	88.7	62.1	84.8	110.8	135.2	133.3	87.60	184.19

<sup>1</sup> Based upon farm price Dec. 1.

SWEET POTATOES—Continued.

TABLE 106.—Sweet potatoes: Farm price, cents per bushel on 1st of each month, 1910-1919.

Date.	1919	1918	1917	1916	1915	1914	1913	1912	1911	1910	Average.
Jan. 1.....	142.1	117.2	90.1	64.9	79.0	79.2	80.4	83.0	75.0	.....	90.1
Feb. 1.....	143.1	123.1	95.8	71.2	82.0	84.3	85.4	90.2	80.4	76.8	93.2
Mar. 1.....	153.7	142.7	110.7	77.3	84.7	86.7	88.9	98.0	84.4	79.4	100.6
Apr. 1.....	160.7	151.6	124.0	78.0	90.7	89.6	92.6	109.9	91.2	82.4	107.1
May 1.....	174.6	155.0	141.3	80.5	95.6	94.5	93.8	118.0	99.3	83.4	113.6
June 1.....	173.7	148.8	149.4	83.4	96.7	91.2	92.0	115.0	98.7	79.4	113.1
July 1.....	152.8	134.3	140.5	79.4	88.9	82.6	90.1	112.2	99.0	75.1	106.2
Aug. 1.....	167.9	144.7	129.3	87.1	85.8	97.5	94.1	107.8	105.8	78.2	109.8
Sept. 1.....	175.4	156.2	132.6	89.9	84.6	92.8	94.3	95.7	102.6	81.2	110.5
Oct. 1.....	151.7	160.6	116.1	83.7	72.7	87.3	83.9	84.4	91.8	77.6	101.3
Nov. 1.....	143.9	146.0	111.2	80.6	63.7	76.3	75.7	76.8	80.9	71.8	92.7
Dec. 1.....	133.3	135.2	110.8	84.8	62.1	73.0	72.6	72.6	75.5	67.1	88.7

TABLE 107.—Sweet Potatoes: Wholesale price per barrel, 1913-1919.

Date.	Baltimore.			St. Louis.			New Orleans.			New York.		
	All grades.			All grades (per bushel).			All grades.			Jersey and Southern.		
	Low.	High.	Average.	Low.	High.	Average.	Low.	High.	Average.	Low.	High.	Average.
1913.												
January-June.....	\$2.00	\$3.50	.....	\$1.63	\$3.75	.....	\$2.00	\$2.00	.....	\$1.75	\$3.00	.....
July-December.....	.75	7.00	.....	.88	6.25	.....	2.00	2.00	.....	.40	5.50	.....
1914.												
January-June.....	1.00	2.50	.....	1.50	2.50	.....	1.00	3.20	.....	.75	2.00	.....
July-December.....	1.00	5.50	.....	1.75	4.50	.....	.80	3.50	.....	.75	5.00	.....
1915.												
January-June.....	1.50	5.50	.....	2.50	4.50	.....	1.00	3.00	.....	2.00	3.50	.....
July-December.....	.75	6.50	.....	1.50	3.40	.....	.70	3.00	.....	.50	5.00	.....
1916.												
January-June.....	1.00	3.00	.....	1.50	2.65	.....	.50	1.70	.....	1.00	2.50	.....
July-December.....	1.25	5.50	.....	2.00	3.25	.....	.80	2.50	.....	1.00	5.50	.....
1917.												
January-June.....	2.75	6.00	.....	.75	2.75	.....	.65	2.25	.....	2.50	5.25	.....
July-December.....	.50	12.00	.....	.40	2.50	.....	.80	1.60	.....	.50	9.00	.....
1918.												
January-June.....	1.00	8.00	\$5.02	.80	2.25	\$1.79	2.00	7.00	\$3.44	1.50	2.50	\$2.00
July-December.....	2.50	10.00	5.88	.65	3.25	1.67	1.00	4.80	2.85	1.25	10.00	4.22
1919.												
January.....	5.00	7.50	6.34	1.25	2.50	1.85	1.00	3.25	2.09	5.50	6.00	5.75
February.....	5.50	9.00	7.00	1.35	2.75	2.07	1.25	3.50	2.64	5.50	6.00	5.75
March.....	4.00	9.00	6.66	1.25	2.75	2.18	2.00	3.50	2.55	5.00	7.00	6.00
April.....	6.00	10.00	7.78	1.75	3.00	2.46	1.75	4.50	2.62	5.00	8.50	6.56
May.....	7.00	11.00	9.32	2.50	4.25	3.45	.....	.....	.....	.....	.....	.....
June.....	9.00	11.00	10.00	.....	.....	.....	5.50	5.50	5.50	.....	.....	.....
January-June.....	4.00	11.00	7.85	1.25	4.25	2.40	1.00	5.50	3.08	5.00	8.50	6.02
July.....	.....	.....	.....	.....	.....	.....	.....	.....	.....	.....	.....	.....
August.....	3.00	12.00	6.24	1.50	3.25	2.78	.....	.....	.....	.....	.....	.....
September.....	2.25	4.25	3.19	1.00	2.50	1.42	1.50	3.25	2.30	1.50	5.00	2.75
October.....	2.25	3.50	2.80	.90	1.25	1.00	1.00	2.25	1.83	1.75	4.75	3.05
November.....	4.00	5.00	4.57	.90	1.35	1.08	.75	2.25	1.61	1.75	5.25	3.10
December.....	3.00	6.00	4.54	1.25	2.00	1.62	.75	3.00	1.47	.....	.....	.....
July-December.....	2.25	12.00	4.27	.90	3.25	1.58	.75	3.25	1.80	1.50	5.25	2.97

## HAY.

TABLE 108.—Hay: Acreage, production, value, exports, etc., in the United States, 1849-1919.

NOTE.—Figures in *italics* are census returns; figures in roman are estimates of the Department of Agriculture. Estimates of acres are obtained by applying estimated percentages of increase or decrease to the published numbers of the preceding year, except that a revised base is used for applying percentage estimates whenever new census data are available.

Year.	Acreage.	Average yield per acre.	Production.	Average farm price per ton Dec. 1.	Farm value Dec. 1.	Chicago prices No. 1 timothy per ton, by carload lots.				Domestic exports fiscal year beginning July 1.
						December.		Following May.		
						Low.	High.	Low.	High.	
<i>1849</i>	<i>Acres.</i>	<i>Tons.<sup>1</sup></i>	<i>Tons.<sup>1</sup></i>	<i>Dolls.</i>	<i>Dollars.</i>	<i>Dolls.</i>	<i>Dolls.</i>	<i>Dolls.</i>	<i>Dolls.</i>	<i>Tons.<sup>2</sup></i>
<i>1859</i>			<i>13,839,000</i>							
			<i>19,084,000</i>							
1866	17,669,000	1.23	21,779,000	10.14	229,836,000					5,028
1867	20,921,000	1.31	26,277,000	10.21	268,301,000					5,645
1868	21,542,000	1.21	26,142,000	10.08	263,589,000					
1869	18,591,000	1.42	26,420,000	10.18	268,933,000					6,723
<i>1869</i>			<i>27,316,000</i>							
1870	19,862,000	1.23	24,525,000	12.47	305,743,000					4,581
1871	19,009,000	1.17	22,239,000	14.30	317,940,000					5,266
1872	20,319,000	1.17	23,813,000	12.94	308,025,000					4,557
1873	21,834,000	1.15	25,085,000	12.53	314,241,000					4,889
1874	21,770,000	1.15	25,134,000	11.94	300,222,000					7,183
1875	23,508,000	1.19	27,874,000	10.78	300,378,000					7,528
1876	25,283,000	1.22	30,867,000	8.97	276,991,000			9.00	10.00	7,287
1877	25,368,000	1.25	31,629,000	8.37	254,880,000	9.50	10.50	9.75	10.75	9,514
1878	26,931,000	1.47	39,608,000	7.20	285,016,000	8.00	8.50	9.00	11.50	8,127
1879	27,485,000	1.29	35,493,000	9.32	339,804,000	14.00	14.50	14.00	15.00	13,739
<i>1879</i>	<i>30,631,000</i>	<i>1.15</i>	<i>35,151,000</i>							
1880	25,864,000	1.23	31,925,000	11.65	371,811,000	15.00	15.50	17.00	19.00	12,662
1881	30,889,000	1.14	35,135,000	11.82	415,131,000	16.00	16.50	15.90	16.50	10,570
1882	32,340,000	1.18	38,138,000	9.73	371,170,000	11.50	12.25	12.00	13.00	13,309
1883	35,516,000	1.32	46,864,000	8.19	383,834,000	9.00	10.00	12.50	17.00	16,908
1884	38,572,000	1.26	48,470,000	8.17	396,139,000	10.00	11.50	15.50	17.50	11,142
1885	39,850,000	1.12	44,732,000	8.71	389,753,000	11.00	12.00	10.00	12.00	13,390
1886	36,502,000	1.15	41,796,000	8.46	353,438,000	9.50	10.50	11.00	12.50	13,873
1887	37,665,000	1.10	41,454,000	9.97	413,440,000	13.50	14.50	17.00	21.00	18,198
1888	38,592,000	1.21	46,643,000	8.76	408,500,000	11.00	11.50	10.50	21.00	21,928
1889	52,949,000	1.26	66,831,000	7.04	470,394,000	9.00	10.00	9.00	14.00	36,274
<i>1889</i>	<i>62,949,000</i>	<i>1.26</i>	<i>66,831,000</i>							
1890	50,713,000	1.19	60,198,000	7.87	473,570,000	9.00	10.50	12.50	15.50	28,066
1891	51,044,000	1.19	60,818,000	8.12	494,114,000	12.50	15.00	13.50	14.00	35,201
1892	50,853,000	1.18	59,824,000	8.20	490,428,000	11.00	11.50	12.00	18.50	33,084
1893	49,613,000	1.33	65,766,000	8.68	570,883,000	10.90	10.50	10.00	10.50	54,446
1894	48,321,000	1.14	54,874,000	8.54	468,578,000	10.00	11.00	10.00	10.25	47,117
1895	44,206,000	1.06	47,079,000	8.35	393,136,000	12.00	12.50	11.50	12.00	59,052
1896	43,260,000	1.37	59,282,000	6.55	388,146,000	8.00	8.50	8.50	9.00	61,658
1897	42,427,000	1.43	60,665,000	6.62	401,391,000	8.00	8.50	9.50	10.50	81,827
1898	42,781,000	1.55	66,377,000	6.00	398,061,000	8.00	8.25	9.50	10.50	64,916
1899	41,328,000	1.37	56,656,000	7.27	411,926,000	10.50	11.50	10.50	12.50	72,716
<i>1899</i>	<i>48,127,000</i>	<i>1.25</i>	<i>58,828,000</i>							
1900	39,133,000	1.28	50,111,000	8.89	445,539,000	11.50	14.00	12.50	13.50	89,364
1901	39,391,000	1.28	50,591,000	10.01	506,192,000	13.00	13.50	12.50	13.50	153,431
1902	39,825,000	1.50	59,858,000	9.66	542,036,000	12.00	12.50	13.50	15.00	50,974
1903	39,934,000	1.54	61,306,000	9.07	556,276,000	10.00	12.00	12.00	15.00	60,780
1904	39,999,000	1.52	60,696,000	8.72	529,108,000	10.50	11.50	11.00	12.00	66,557
1905	39,362,000	1.54	60,532,000	8.52	515,960,000	10.00	12.00	11.50	12.50	70,172
1906	42,476,000	1.35	57,146,000	10.37	592,549,000	15.50	18.00	15.50	20.50	58,602
1907	44,028,000	1.45	63,677,000	11.68	743,507,000	13.00	17.50	13.00	14.00	77,281
1908	45,970,000	1.52	70,050,000	9.02	631,683,000	11.50	12.00	12.00	13.00	64,641
1909	45,744,000	1.42	64,938,000							
<i>1909</i>	<i>51,041,000</i>	<i>1.35</i>	<i>68,832,000</i>	<i>10.49</i>	<i>722,385,000</i>	<i>16.00</i>	<i>17.00</i>	<i>12.50</i>	<i>16.00</i>	<i>55,007</i>
1910 <sup>3</sup>	51,015,000	1.36	69,378,000	12.14	842,252,000	16.00	19.00	18.50	23.50	55,223
1911	48,240,000	1.14	54,916,000	14.29	784,926,000	20.00	22.00	24.00	28.00	59,730
1912	49,530,000	1.47	72,691,000	11.79	856,695,000	13.00	18.00	14.00	16.50	60,720
1913	48,954,000	1.31	64,116,000	12.43	797,077,000	14.50	18.00	15.00	17.50	50,151
1914	49,145,000	1.43	70,071,000	11.12	779,068,000	15.00	16.90	16.50	17.50	105,508
1915	51,108,000	1.68	85,920,000	10.63	913,644,000	14.50	16.50	17.50	20.00	178,336
1916	55,721,000	1.64	91,192,000	11.22	1,022,930,000	15.00	17.50	19.00	22.00	85,529
1917	55,203,000	1.51	83,308,000	17.09	1,423,766,000	26.00	28.00	20.00	26.00	30,145
1918	55,755,000	1.37	76,660,000	20.13	1,543,494,000	29.00	31.00	34.00	37.00	29,013
1919	56,348,000	1.62	91,326,000	20.15	1,839,967,000	28.00	32.00			

<sup>1</sup> 2,000 pounds.<sup>2</sup> 2,240 pounds.<sup>3</sup> Figures adjusted to census basis.

HAY—Continued.

TABLE 109.—Hay: Revised acreage, production, and farm value, 1879 and 1889-1909.

[See head note to Table 93.]

Year.	Acreage.	Average yield per acre.	Production.	Average farm price per ton Dec. 1.	Farm value Dec. 1.
	<i>Acres.</i>	<i>Tons.</i>	<i>Tons.</i>	<i>Dollars.</i>	<i>Dollars.</i>
1879.....	30,631,000	1.30	39,862,000	9.31	371,945,000
1889.....	39,004,000	1.26	49,181,000	7.76	381,481,000
1890.....	40,038,000	1.23	49,057,000	8.18	401,111,000
1891.....	41,258,000	1.18	48,759,000	8.89	433,276,000
1892.....	42,191,000	1.17	49,238,000	8.95	410,710,000
1893.....	42,413,000	1.31	55,575,000	9.48	527,044,000
1894.....	42,772,000	1.18	50,468,000	8.96	452,079,000
1895.....	40,832,000	1.02	41,838,000	9.46	395,647,000
1896.....	40,978,000	1.33	54,380,000	7.48	406,957,000
1897.....	41,336,000	1.42	58,878,000	7.28	428,919,000
1898.....	43,120,000	1.55	66,772,000	6.63	442,905,000
1899.....	43,127,000	1.33	57,450,000	8.20	470,844,000
1900.....	42,070,000	1.27	53,231,000	9.72	517,399,000
1901.....	42,066,000	1.33	55,819,000	9.91	553,328,000
1902.....	42,962,000	1.52	65,296,000	9.19	599,781,000
1903.....	43,400,000	1.57	68,154,000	9.35	637,485,000
1904.....	44,645,000	1.55	69,192,000	8.91	616,369,000
1905.....	45,991,000	1.59	72,973,000	8.59	627,023,000
1906.....	47,891,000	1.39	66,341,000	10.43	692,116,000
1907.....	49,098,000	1.47	72,261,000	11.78	850,915,000
1908.....	51,196,000	1.53	78,440,000	9.14	716,644,000
1909.....	51,041,000	1.46	74,384,000	10.58	786,722,000

TABLE 110.—Hay: Acreage, production, and total farm value, by States, 1919.

[000 omitted.]

State.	Acreage.	Production.	Farm value Dec. 1.	State.	Acreage.	Production.	Farm value Dec. 1.
	<i>Acres.</i>	<i>Tons.</i>	<i>Dollars.</i>		<i>Acres.</i>	<i>Tons.</i>	<i>Dollars.</i>
Maine.....	1,120	1,456	27,227	North Dakota.....	605	908	12,803
New Hampshire....	450	675	16,200	South Dakota.....	890	1,558	21,033
Vermont.....	910	1,456	29,266	Nebraska.....	1,769	4,299	60,186
Massachusetts.....	410	656	17,712	Kansas.....	1,832	4,507	71,211
Rhode Island.....	57	86	2,752	Kentucky.....	1,115	1,561	39,649
Connecticut.....	340	544	16,429	Tennessee.....	1,280	1,792	48,384
New York.....	4,386	6,579	134,870	Alabama.....	1,367	1,367	30,484
New Jersey.....	325	488	14,201	Mississippi.....	405	648	13,284
Pennsylvania.....	2,978	4,318	163,632	Louisiana.....	250	450	10,350
Delaware.....	82	105	2,730	Texas.....	662	1,258	22,644
Maryland.....	450	630	15,120	Oklahoma.....	700	1,540	23,254
Virginia.....	1,100	1,650	39,105	Arkansas.....	550	770	15,785
West Virginia.....	810	1,215	31,104	Montana.....	752	827	19,021
North Carolina.....	800	1,040	25,168	Wyoming.....	605	853	19,619
South Carolina.....	275	358	11,098	Colorado.....	1,065	2,396	44,326
Georgia.....	557	613	15,509	New Mexico.....	235	646	11,757
Florida.....	113	141	3,243	Arizona.....	169	676	13,520
Ohio.....	2,879	3,973	86,611	Utah.....	453	938	20,542
Indiana.....	2,290	3,080	66,528	Nevada.....	225	526	10,310
Illinois.....	3,250	4,810	102,934	Idaho.....	650	1,625	35,750
Michigan.....	2,650	3,180	74,412	Washington.....	794	1,906	43,838
Wisconsin.....	2,677	4,738	96,181	Oregon.....	854	1,452	27,733
Minnesota.....	2,000	3,800	55,109	California.....	2,352	4,257	73,220
Iowa.....	3,140	5,181	90,149				
Missouri.....	2,810	3,794	73,983	United States.....	56,348	91,326	1,839,967

HAY—Continued.

TABLE 111.—Hay: Yield per acre, price per ton Dec. 1, and value per acre, by States.

State.	Average yield per acre (tons).											Farm price per ton (dollars).					Value per acre (dollars). <sup>1</sup>		
	10-year average 1910-1919.	1910	1911	1912	1913	1914	1915	1916	1917	1918	1919	10-year average 1910-1919.	1915	1916	1917	1918	1919	5-year average 1914-1918.	1919
Me.	1.21	1.25	1.10	1.16	1.00	1.15	1.15	1.45	1.35	1.15	1.30	13.89	14.90	12.40	11.10	13.90	18.70	16.23	24.31
N. H.	1.21	1.20	1.05	1.25	1.00	1.15	1.00	1.45	1.35	1.15	1.50	16.89	17.40	14.50	12.00	18.80	24.00	19.16	35.00
Vt.	1.42	1.35	1.30	1.50	1.28	1.20	1.35	1.70	1.62	1.30	1.60	14.55	15.50	12.60	11.50	16.30	20.19	19.94	32.16
Mass.	1.35	1.28	1.08	1.25	1.21	1.32	1.50	1.56	1.50	1.20	1.60	22.01	22.00	19.00	19.90	26.00	27.00	30.41	43.20
R. I.	1.25	1.18	1.00	1.13	1.17	1.17	1.24	1.35	1.50	1.30	1.50	22.78	22.50	20.00	20.30	25.50	32.00	28.43	48.00
Conn.	1.33	1.35	1.10	1.15	1.14	1.25	1.35	1.55	1.50	1.30	1.60	21.68	20.00	18.50	19.50	24.00	30.20	28.10	48.32
N. Y.	1.31	1.32	1.02	1.25	1.14	1.20	1.30	1.02	1.46	1.25	1.50	16.00	15.70	11.90	15.10	20.40	20.50	20.95	30.75
N. J.	1.41	1.50	1.05	1.44	1.30	1.35	1.45	1.60	1.45	1.50	1.50	21.24	19.00	17.60	20.00	28.00	29.10	30.60	43.65
Pa.	1.37	1.38	1.00	1.43	1.32	1.28	1.40	1.60	1.41	1.41	1.45	17.46	15.60	13.80	17.50	23.70	24.00	24.12	34.80
Del.	1.25	1.43	.88	1.33	1.30	1.10	1.20	1.45	1.26	1.25	1.28	19.24	17.00	15.90	20.50	28.00	26.00	24.60	33.28
Md.	1.27	1.35	.72	1.51	1.26	1.15	1.20	1.48	1.25	1.35	1.40	18.36	16.20	14.00	19.90	26.80	24.00	23.76	33.60
Va.	1.17	1.19	.64	1.20	1.27	.72	1.35	1.35	1.16	1.35	1.50	18.16	15.70	15.00	21.30	23.00	23.70	21.92	35.55
W. Va.	1.25	1.20	.66	1.38	1.25	.92	1.50	1.54	1.27	1.30	1.50	18.18	15.00	14.50	21.10	23.50	25.60	23.60	38.40
N. C.	1.31	1.50	1.05	1.30	1.31	1.15	1.85	1.30	1.13	1.20	1.30	18.08	16.50	17.50	19.70	21.00	24.20	24.06	31.46
S. C.	1.19	1.25	1.08	1.15	1.16	1.15	1.30	1.30	1.08	1.10	1.30	19.67	15.60	16.70	20.60	26.10	31.00	22.50	40.30
Ga.	1.25	1.40	1.35	1.35	1.40	1.35	1.15	1.15	1.03	1.24	1.10	18.46	15.10	16.20	20.00	23.50	25.30	21.52	27.83
Fla.	1.25	1.33	1.30	1.25	1.35	1.35	1.20	1.25	1.10	1.14	1.25	18.07	16.00	16.00	18.20	18.50	23.00	20.71	28.75
Ohio.	1.34	1.39	.98	1.36	1.30	1.13	1.44	1.57	1.42	1.40	1.38	15.69	12.70	10.60	19.00	22.20	21.80	21.68	30.08
Ind.	1.28	1.30	.94	1.37	1.00	1.00	1.50	1.44	1.45	1.45	1.40	15.03	11.00	10.90	18.70	19.80	21.60	20.43	30.24
Ill.	1.24	1.33	.82	1.30	.98	.85	1.54	1.45	1.25	1.35	1.48	15.46	10.80	11.30	20.00	21.00	21.40	19.72	31.67
Mich.	1.30	1.30	1.16	1.33	1.05	1.28	1.40	1.70	1.50	1.03	1.20	15.47	12.20	10.00	17.20	23.50	23.40	19.91	28.03
Wis.	1.55	1.00	1.20	1.60	1.62	1.75	1.75	1.70	1.70	1.40	1.77	14.39	9.90	11.60	17.30	21.60	20.30	22.59	35.93
Minn.	1.55	1.00	1.00	1.53	1.50	1.89	1.91	1.85	1.55	1.40	1.00	9.42	6.40	7.00	12.10	14.10	14.50	21.08	27.55
Iowa.	1.37	1.05	.80	1.40	1.48	1.38	1.80	1.60	1.23	1.30	1.65	12.14	8.70	9.00	16.80	18.20	17.40	17.66	28.71
Mo.	1.07	1.30	.60	1.30	.60	.70	1.52	1.30	1.15	.90	1.35	13.57	8.50	9.30	17.50	20.50	19.50	14.62	26.32
N. Dak.	1.23	.55	1.10	1.40	1.14	1.45	1.50	1.70	.88	1.10	1.50	8.30	5.70	6.00	11.50	14.60	14.10	10.49	21.15
S. Dak.	1.45	.80	.55	1.46	1.20	1.70	2.00	1.90	1.50	1.60	1.75	7.87	5.30	5.40	10.60	10.00	13.50	12.49	23.62
Nebr.	1.64	1.00	.85	1.35	1.34	1.69	2.60	2.10	1.60	1.40	2.43	10.19	5.80	7.10	15.20	17.20	14.00	18.01	34.02
Kans.	1.61	1.15	.85	1.50	.90	1.51	2.30	1.55	2.18	1.73	2.46	11.02	5.60	7.60	16.60	19.40	15.80	21.12	38.87
Ky.	1.21	1.29	.95	1.23	.87	.95	1.40	1.40	1.30	1.30	1.40	17.11	12.50	12.60	20.30	23.70	25.40	21.51	35.56
Tenn.	1.29	1.40	1.00	1.30	1.21	1.20	1.47	1.38	1.20	1.35	1.40	17.83	13.90	15.00	19.30	24.00	27.00	23.42	37.80
Ala.	1.19	1.43	1.40	1.25	1.36	1.31	1.45	1.10	.80	.81	1.00	15.28	12.40	13.00	16.20	20.30	22.30	15.95	22.30
Miss.	1.42	1.42	1.50	1.48	1.33	1.45	1.49	1.40	1.45	1.20	1.60	13.75	11.00	11.00	15.30	18.50	20.50	18.52	32.80
La.	1.62	1.75	1.30	1.65	1.50	1.90	1.75	1.70	1.60	1.30	1.80	14.05	10.30	11.00	14.30	21.20	23.00	21.09	41.40
Tex.	1.33	1.15	1.00	1.40	1.16	1.75	1.70	1.20	1.00	1.00	1.90	13.72	7.90	10.50	20.00	24.90	18.00	17.62	34.20
Okla.	1.41	1.05	.80	1.25	.85	1.13	2.30	1.70	1.60	1.20	2.20	10.67	5.60	9.00	15.40	19.50	15.10	17.03	33.22
Ark.	1.30	1.35	1.15	1.23	1.20	1.05	1.60	1.25	1.47	1.30	1.40	14.06	10.30	12.50	15.40	19.50	20.50	18.73	28.70
Mont.	1.74	1.40	2.00	1.90	1.80	2.50	2.00	1.70	1.40	1.60	1.10	12.88	7.50	11.00	18.60	19.00	23.00	22.57	25.30
Wyo.	1.98	2.40	2.10	1.90	1.90	2.30	2.20	1.80	1.70	2.10	1.41	11.94	7.80	12.00	17.00	14.00	23.00	22.86	32.43
Colo.	2.18	2.00	2.00	2.19	2.05	2.40	2.20	2.05	2.45	2.22	2.25	11.54	7.60	11.00	16.60	15.50	18.50	26.42	41.62
N. Mex.	2.27	2.10	2.60	2.33	2.08	2.50	2.20	2.00	1.90	2.20	2.75	13.64	8.80	14.00	21.00	20.00	18.20	30.90	50.05
Ariz.	3.43	2.10	3.80	3.40	4.00	3.20	3.20	3.80	3.50	3.20	4.00	14.97	9.60	14.50	24.80	24.00	20.00	55.52	80.00
Utah.	2.54	3.00	2.50	2.78	2.33	2.75	2.50	2.20	2.90	2.35	2.07	11.98	8.00	15.00	15.00	17.10	21.90	31.57	45.33
Nev.	2.90	3.40	3.40	3.00	2.75	3.25	3.00	2.40	2.90	2.60	2.34	12.08	7.50	9.60	15.90	19.90	19.60	34.07	45.86
Idaho.	2.82	3.09	3.10	2.80	2.90	2.65	2.70	2.50	3.00	3.00	2.50	11.28	7.70	12.10	16.00	17.60	22.00	34.24	55.00
Wash.	2.23	2.10	2.40	2.20	2.30	2.20	2.30	2.40	2.20	1.80	2.40	15.27	10.80	13.80	20.00	25.40	23.00	34.38	55.20
Oreg.	2.04	2.10	2.10	2.20	2.00	2.20	2.30	1.95	1.80	1.70	1.52	9.50	10.90	17.50	20.00	19.10	26.90	32.47	
Calif.	1.72	1.83	1.75	1.53	1.50	1.95	1.80	1.75	2.00	1.25	1.81	13.61	11.20	12.60	19.20	20.00	17.20	24.82	31.13
U. S.	1.45	1.36	1.14	1.47	1.31	1.43	1.68	1.64	1.51	1.37	1.62	14.10	10.63	11.22	17.09	20.13	20.15	21.11	32.65

<sup>1</sup> Based upon farm price Dec. 1.



HAY—Continued.

TABLE 112.—Hay: Stocks on farms May 1.

Year.	Production of all hay preceding year (tons).	Per cent on farms May 1.	Tons on farms May 1.	Price per ton May 1.
1910.....	87,216,000	11.5	10,053,000	\$11.08
1911.....	82,529,000	12.4	10,222,000	11.69
1912.....	67,071,000	8.5	5,732,000	16.31
1913.....	90,734,000	14.9	13,523,000	10.42
1914.....	79,179,000	12.2	9,631,000	11.63
1915.....	88,686,000	12.2	10,797,000	11.03
1916.....	107,263,000	13.5	14,452,000	11.27
1917.....	110,992,000	11.4	12,659,000	13.94
1918.....	98,439,000	11.7	11,476,000	17.07
1919.....	91,139,000	9.4	8,559,000	22.31

TABLE 113.—Hay: Farm price per ton on 1st of each month, 1910-1919.

Date.	1919	1918	1917	1916	1915	1914	1913	1912	1911	1910	Average.
Jan. 1.....	\$19.92	\$18.09	\$10.86	\$10.07	\$10.47	\$11.70	\$11.11	\$13.75	\$11.69	\$10.45	\$12.81
Feb. 1.....	19.79	18.88	11.34	10.55	10.83	11.67	10.86	14.39	11.80	11.34	13.14
Mar. 1.....	19.82	19.14	11.54	10.75	10.89	11.69	10.61	14.66	11.57	11.61	13.23
Apr. 1.....	20.52	18.68	12.53	10.85	10.98	11.52	10.43	15.64	11.36	11.53	13.40
May 1.....	22.31	17.97	13.94	11.27	11.03	11.63	10.42	16.31	11.69	11.08	13.76
June 1.....	23.30	17.13	14.68	11.47	11.16	11.64	10.55	16.22	12.38	10.84	13.94
July 1.....	21.73	16.07	13.95	11.10	10.85	11.29	10.47	14.32	13.19	10.75	13.37
Aug. 1.....	20.16	15.92	12.90	9.89	10.19	10.76	10.43	12.03	13.83	10.75	12.69
Sept. 1.....	20.52	17.42	13.26	9.72	9.95	11.10	11.04	11.21	13.63	11.21	12.91
Oct. 1.....	19.79	18.45	13.83	9.65	9.83	10.96	11.45	11.02	13.53	11.12	12.96
Nov. 1.....	19.36	19.27	15.16	9.99	9.98	10.78	11.51	11.08	13.61	11.20	13.19
Dec. 1.....	20.15	20.13	17.09	11.22	10.63	11.12	12.43	11.79	14.29	12.14	14.10
Average.....	20.46	18.10	13.53	10.48	10.50	11.28	11.02	13.24	12.83	11.21	13.26

TABLE 114.—Timothy and clover hay: Farm price per ton, 15th of each month, 1915-1919.

Date.	Timothy.					Clover.				
	1919	1918	1917	1916	1915	1919	1918	1917	1916	1915
Jan. 15.....	\$23.48	\$21.37	\$12.61	\$13.11	\$14.07	\$21.69	\$19.82	\$11.38	\$11.24	\$13.07
Feb. 15.....	22.69	22.25	12.91	13.39	14.28	21.11	21.11	11.65	11.41	13.36
Mar. 15.....	22.68	22.53	13.20	13.61	14.28	21.25	21.37	11.90	11.70	13.41
Apr. 15.....	24.74	21.47	14.26	14.00	14.53	23.36	19.68	13.06	11.87	13.65
May 15.....	27.27	20.40	15.31	14.50	14.74	25.33	18.30	13.94	12.52	13.79
June 15.....	27.50	18.55	15.76	14.71	14.33	25.48	16.54	14.22	12.46	12.78
July 15.....	24.22	17.61	14.68	12.97	13.43	22.02	15.73	12.95	10.84	11.65
Aug. 15.....	23.89	18.98	14.11	11.74	12.39	21.58	17.18	12.76	9.93	10.87
Sept. 15.....	23.65	20.85	14.89	11.57	12.32	21.74	19.27	13.79	10.01	10.82
Oct. 15.....	23.04	22.60	16.23	11.54	12.14	21.17	20.60	15.01	10.08	10.60
Nov. 15.....	22.90	22.93	18.33	12.03	12.24	21.61	21.13	17.14	10.46	10.59
Dec. 15.....	23.71	22.94	20.31	12.29	12.73	22.60	21.28	18.67	10.86	10.95

HAY—Continued.

TABLE 115.—*Alfalfa and prairie hay: Farm price per ton, 15th of each month, 1915-1919.*

	Alfalfa.					Prairie.				
	1919	1918	1917	1916	1915	1919	1918	1917	1916	1915
Jan. 15.....	\$20.42	\$21.27	\$12.79	\$9.89	\$9.48	\$16.33	\$15.39	\$8.58	\$7.38	\$7.65
Feb. 15.....	20.91	21.38	13.63	10.35	9.32	16.55	15.74	8.60	7.34	7.86
Mar. 15.....	21.40	20.82	14.68	10.74	9.79	17.38	15.47	9.32	7.39	8.03
Apr. 15.....	22.28	18.97	17.68	10.73	9.81	18.85	14.47	10.94	7.56	8.58
May 15.....	23.32	17.84	17.92	10.56	9.58	20.22	12.75	12.02	7.71	8.29
June 15.....	20.89	16.74	16.77	10.49	8.50	18.71	12.78	11.84	7.97	7.72
July 15.....	20.15	16.58	14.13	9.87	8.28	16.10	12.51	10.11	7.25	7.37
Aug. 15.....	20.72	18.22	15.28	9.80	8.28	16.10	13.26	10.82	6.96	6.83
Sept. 15.....	20.89	19.72	16.33	10.06	8.22	15.90	14.35	11.40	7.21	6.64
Oct. 15.....	20.56	20.23	17.59	10.25	8.14	15.88	15.06	12.29	7.26	6.44
Nov. 15.....	21.63	20.42	19.19	11.37	8.72	16.91	15.47	13.32	7.85	6.75
Dec. 15.....	22.95	20.74	20.39	12.31	9.52	17.19	16.30	14.91	8.14	6.95

TABLE 116.—*Hay: Wholesale price (baled) per ton, 1913-1919.*

Date.	Chicago.			Cincinnati.			St. Louis. <sup>1</sup>			New York.			San Francisco.		
	No. 1 timothy.			No. 1 timothy.			No. 1 timothy.			No. 1 timothy.			No. 1 wheat; light bales.		
	Low.	High.	Average.	Low.	High.	Average.	Low.	High.	Average.	Low.	High.	Average.	Low.	High.	Average.
1913.															
January-June.....	Dols. 13.00	Dols. 18.00	Dols. 15.15	Dols. 13.50	Dols. 19.00	Dols. 16.42	Dols. 12.00	Dols. 17.50	Dols. 17.57	Dols. 19.50	Dols. 23.00	Dols. 20.93	Dols. 24.30	Dols. 25.75	Dols. 24.66
July-December.....	13.50	19.50	16.15	15.00	21.00	18.89	14.50	22.50	18.10	20.00	22.00	21.09	19.50	22.19	20.19
1914.															
January-June.....	13.50	17.50	15.62	17.50	21.00	18.91	15.00	23.00	19.24	19.50	23.00	21.34	13.50	18.75	15.87
July-December.....	13.00	18.50	15.79	17.50	21.50	19.06	14.50	22.50	18.53	18.50	25.00	21.61	11.90	12.50	11.90
1915.															
January-June.....	14.50	18.00	16.30	18.00	22.00	19.24	16.00	22.00	18.81	18.00	25.00	22.20	11.00	14.00	11.90
July-December.....	12.00	21.00	16.36	13.00	23.00	19.02	12.00	24.00	16.16	24.00	31.50	25.07	13.00	18.00	15.64
1916.															
January-June.....	14.50	20.00	17.27	18.00	24.00	20.76	14.00	21.00	17.95	24.00	31.00	27.19	14.50	19.00	17.03
July-December.....	9.50	18.00	14.98	14.25	18.50	16.31	11.00	19.50	15.40	18.00	28.00	22.37	14.50	20.00	17.30
1917.															
January-June.....	15.00	22.00	17.34	15.00	21.50	17.57	14.50	25.00	18.85	18.00	24.00	21.80	19.00	35.00	26.55
July-December.....	16.50	28.50	23.06	16.50	30.00	23.40	15.00	32.00	25.15	30.00	34.00	25.61	19.00	34.00	25.20
1918.															
January-June.....	16.00	33.00	25.47	19.00	34.25	27.71	19.00	34.50	27.98	20.00	40.00	32.03	27.00	31.00	28.56
July-December.....	17.00	35.00	29.32	21.50	34.50	29.14	23.00	35.00	30.15	27.00	48.00	34.10	24.00	30.00	27.35
1919.															
January.....	27.00	32.00	29.61	29.00	32.00	30.50	23.00	34.00	28.76	28.00	33.00	32.00	24.00	26.00	25.00
February.....	24.00	28.00	26.23	28.00	30.50	29.41	22.00	28.50	25.38	28.00	33.00	29.74	24.00	26.00	25.00
March.....	28.00	33.00	30.40	29.50	35.25	32.28	27.00	34.00	30.64	32.00	36.00	34.62	21.00	26.00	23.85
April.....	30.00	37.00	33.43	33.00	40.00	37.75	29.00	38.00	34.32	35.00	42.00	39.72	21.00	23.00	22.00
May.....	34.00	37.00	35.50	39.50	41.00	40.10	34.00	39.00	36.40	42.00	48.00	44.16	21.00	23.00	22.00
June.....	30.00	36.00	33.82	38.50	42.25	40.08	34.00	39.00	35.08	44.00	48.00	46.68	19.00	21.00	20.00
January-June.....	24.00	37.00	31.49	28.00	42.25	35.02	22.00	39.00	31.93	28.00	48.00	37.92	19.00	26.00	22.98
July.....	32.00	35.00	33.22	33.50	39.25	37.32	24.50	34.00	29.97	37.00	45.00	40.04	17.50	18.00	17.75
August.....	26.00	44.00	33.46	31.00	35.00	33.34	23.00	31.00	27.19	37.00	48.00	43.42	17.50	19.00	17.98
September.....	26.00	33.00	30.58	29.00	30.75	29.59	23.00	30.00	26.21	33.00	38.00	35.05	17.50	19.00	18.25
October.....	27.00	29.00	27.91	26.00	29.75	28.50	22.00	28.50	26.96	33.00	36.00	34.40	17.50	22.00	19.01
November.....	28.00	31.00	29.46	28.00	30.75	29.34	25.00	33.00	27.24	34.00	36.00	35.02	20.00	25.00	22.50
December.....	28.00	32.00	30.98	30.50	33.00	31.81	26.00	33.00	28.74	32.00	36.00	32.68	24.00	27.00	25.30
July-December.....	26.00	44.00	30.94	26.00	39.25	31.65	22.00	34.00	27.72	32.00	48.00	38.77	17.50	27.00	20.13

<sup>1</sup> No. 2 timothy for 1919.

\* Fancy wheat hay, 1913.

HAY—Continued.

TABLE 117.—Wild, salt, and prairie hay: Acreage, production, and total farm value, by States, 1919.

[000 omitted.]

State.	Acreage.	Production.	Farm value Dec. 1.	State.	Acreage.	Production.	Farm value Dec. 1.
	<i>Acres.</i>	<i>Tons.</i>	<i>Dollars.</i>		<i>Acres.</i>	<i>Tons.</i>	<i>Dollars.</i>
Maine.....	25	25	450	North Dakota.....	2,094	2,303	37,769
New Hampshire.....	20	22	484	South Dakota.....	3,550	3,728	65,240
Vermont.....	13	15	270	Nebraska.....	2,771	2,826	49,738
Massachusetts.....	21	25	600	Kansas.....	1,048	1,205	17,954
Rhode Island.....	1	1	25	Kentucky.....	10	12	204
Connecticut.....	16	18	396	Tennessee.....	40	52	1,331
New York.....	55	69	1,104	Alabama.....	35	35	780
New Jersey.....	39	47	940	Mississippi.....	49	64	1,357
Pennsylvania.....	14	18	360	Louisiana.....	40	60	1,320
Delaware.....	8	11	220	Texas.....	214	268	4,744
Maryland.....	6	8	176	Oklahoma.....	630	756	11,491
Virginia.....	25	29	725	Arkansas.....	137	185	3,737
West Virginia.....	7	8	192	Montana.....	450	158	3,966
North Carolina.....	40	40	800	Wyoming.....	300	204	4,774
South Carolina.....	10	11	280	Colorado.....	360	360	6,624
Georgia.....	13	14	399	New Mexico.....	45	45	846
Florida.....	9	10	265	Arizona.....	17	17	221
Ohio.....	2	3	48	Utah.....	88	97	1,765
Indiana.....	50	60	852	Nevada.....	145	109	1,962
Illinois.....	76	103	1,854	Idaho.....	125	125	2,562
Michigan.....	45	56	952	Washington.....	34	41	738
Wisconsin.....	339	461	6,362	Oregon.....	200	200	3,600
Minnesota.....	1,680	2,453	33,361	California.....	177	205	2,460
Iowa.....	478	621	10,184	United States..	15,686	17,340	289,120
Missouri.....	135	157	2,638				

TABLE 118.—Wild, salt, and prairie hay: Acreage, production, and value, United States, 1909-1919.

Year.	Acreage.	Yield per acre.	Production.	Farm price per ton.	Farm value.
	<i>Acres.</i>	<i>Tons.</i>	<i>Tons.</i>	<i>Dollars.</i>	<i>Dollars.</i>
1909 <sup>1</sup> .....	17,186,000	1.07	18,383,000	.....	.....
1910.....	17,187,000	.77	13,151,000	.....	.....
1911.....	17,187,000	.71	12,155,000	.....	.....
1912.....	17,427,000	1.04	18,043,000	.....	.....
1913.....	16,341,000	.92	15,063,000	.....	.....
1914.....	16,752,000	1.11	18,615,000	.....	.....
1915.....	16,796,000	1.27	21,343,000	.....	.....
1916.....	16,635,000	1.19	19,800,000	.....	.....
1917.....	16,212,000	.93	15,131,000	13.49	204,086,000
1918.....	15,365,000	.94	14,479,000	15.23	220,487,000
1919.....	15,686,000	1.11	17,340,000	16.67	289,120,000

<sup>1</sup> Census figures.

## CLOVER AND TIMOTHY SEED.

TABLE 119.—Clover seed: Acreage, production, and value, by States, 1919, and totals, 1916-1918.

State and year.	Acreage.	Average yield per acre.	Production.	Average farm price per bushel Nov. 15.	Farm value Nov. 15.
	<i>Acres.</i>	<i>Bushels.</i>	<i>Bushels.</i>	<i>Dollars.</i>	<i>Dollars.</i>
New York.....	15,000	2.2	33,000	25.00	825,000
Pennsylvania.....	8,000	1.4	11,000	29.20	321,000
Ohio.....	100,000	1.0	100,000	28.20	2,820,000
Indiana.....	75,000	1.0	75,000	27.30	2,048,000
Illinois.....	140,000	1.5	210,000	25.30	5,334,000
Michigan.....	72,000	1.4	101,000	27.50	2,778,000
Wisconsin.....	124,000	2.0	248,000	26.60	6,597,000
Minnesota.....	19,000	2.5	48,000	25.00	1,200,000
Iowa.....	60,000	1.4	84,000	26.70	2,243,000
Missouri.....	20,000	1.7	34,000	23.50	799,000
Nebraska.....	4,000	1.8	7,000	24.20	169,000
Kansas.....	6,000	1.8	11,000	19.00	209,000
Kentucky.....	20,000	1.9	38,000	29.70	1,129,000
Tennessee.....	4,000	1.5	6,000	25.70	154,000
Idaho.....	13,000	5.8	75,000	25.40	1,905,000
Oregon.....	6,000	3.0	18,000	29.80	536,000
Total.....	686,000	1.6	1,099,000	26.45	29,067,000
1918.....	820,000	1.5	1,197,000	19.80	23,705,000
1917.....	821,000	1.8	1,488,000	12.84	19,107,000
1916.....	939,000	1.8	1,706,000	9.18	15,661,000

TABLE 120.—Clover seed: Farm price per bushel, 15th of each month, 1910-1919.

Date.	1919	1918	1917	1916	1915	1914	1913	1912	1911	1910	Average.
Jan. 15.....	\$21.55	\$14.48	\$9.60	\$10.27	\$8.51	\$7.99	\$9.41	\$10.89	\$8.27	\$8.26	\$10.02
Feb. 15.....	21.79	16.46	9.87	10.47	8.60	8.07	10.28	12.22	8.37	8.26	11.44
Mar. 15.....	22.61	17.49	10.32	10.76	8.55	8.17	10.42	12.89	8.56	8.15	11.79
Apr. 15.....	24.81	17.86	10.41	10.58	8.36	8.06	11.00	12.91	8.79	7.91	12.07
May 15.....	24.48	16.56	10.40	9.98	8.14	7.87	10.74	12.53	8.74	7.47	11.69
June 15.....	23.37	15.88	10.29	9.47	7.90	7.96	9.77	11.69	8.80	7.24	11.24
July 15.....	23.25	14.71	10.50	9.15	7.96	8.12	9.78	10.64	8.83	7.17	11.01
Aug. 15.....	24.33	15.20	10.53	9.12	7.94	8.76	9.37	9.80	9.65	7.53	11.22
Sept. 15.....	25.38	16.61	10.89	8.65	8.49	9.10	7.31	9.39	10.19	8.27	11.43
Oct. 15.....	26.47	19.01	11.92	8.54	9.70	8.24	7.00	9.37	10.33	8.13	11.87
Nov. 15.....	26.53	20.03	12.91	9.20	9.67	8.02	7.33	9.06	10.37	7.70	12.08
Dec. 15.....	27.63	20.67	13.53	9.40	10.01	8.12	7.70	9.00	10.62	7.94	12.46

TABLE 121.—Timothy seed: Farm price per bushel, 15th of each month, 1910-1919.

Date.	1919	1918	1917	1916	1915	1914	1913	1912	1911	1910
Jan. 15.....	\$4.34	\$3.57	\$2.44	\$3.05	\$2.63	\$2.07	\$1.79	\$6.99	\$4.12	.....
Feb. 15.....	4.51	3.78	2.46	3.19	2.66	2.12	1.78	7.26	4.51	.....
Mar. 15.....	4.54	3.84	2.70	3.28	2.78	2.30	1.72	7.33	4.93	.....
Apr. 15.....	4.69	3.74	2.76	3.51	2.69	2.28	1.74	7.27	5.17	.....
May 15.....	5.05	3.84	3.09	3.33	2.75	2.38	1.76	7.16	5.24	.....
June 15.....	4.63	3.56	3.09	3.26	2.65	2.23	1.77	6.68	5.24	.....
July 15.....	4.49	3.67	3.04	3.08	2.57	2.32	1.94	5.96	5.48	.....
Aug. 15.....	4.58	3.87	3.23	2.36	2.56	2.43	2.01	3.20	6.52	.....
Sept. 15.....	4.55	3.79	3.31	2.22	2.62	2.46	2.13	2.09	6.65	\$3.77
Oct. 15.....	4.78	4.08	3.61	2.27	2.72	2.34	2.02	1.95	6.91	4.03
Nov. 15.....	4.67	4.26	3.25	2.25	2.91	2.34	2.08	1.82	6.90	4.08
Dec. 15.....	4.98	4.21	3.37	2.31	2.86	2.18	2.10	1.79	6.72	4.11

CLOVER AND TIMOTHY SEED.

TABLE 122.—Clover and timothy seed: Wholesale price, 1913-1919.

Date.	Clover (bushels of 60 pounds).												Timothy.											
	Cincinnati.			Chicago.			Toledo.			Detroit.			Cincinnati.			Chicago.			Milwaukee.			St. Louis.		
	Prime.			Poor to prime.			Poor to choice.			All grades.			Per bushel (45 pounds).			Poor to choice (per 100 pounds).			Per 100 pounds.			Poor to prime (per 100 pounds).		
	Low.	High.	Average.	Low.	High.	Average.	Low.	High.	Average.	Low.	High.	Average.	Low.	High.	Average.	Low.	High.	Average.	Low.	High.	Average.	Low.	High.	Average.
1913.																								
January-June.....	\$8.00	\$11.50	\$9.34	\$5.00	\$22.00	\$14.51	\$7.50	\$15.85	\$12.30	\$11.15	\$13.40	.....	\$1.50	\$1.80	\$1.65	\$2.50	\$5.35	\$3.04	\$2.50	\$4.60	\$3.23	\$2.00	\$3.75	\$2.82
July-December.....	5.00	9.00	6.84	7.00	16.00	10.43	6.80	12.75	9.11	7.50	9.45	.....	1.50	2.25	1.94	3.50	5.90	4.65	3.50	5.50	4.61	2.25	5.50	4.30
1914.																								
January-June.....	5.00	9.00	6.95	7.00	15.00	11.03	7.25	9.47	8.26	7.40	9.40	.....	1.40	2.25	1.80	2.50	5.75	4.34	3.00	5.50	4.02	2.25	5.35	4.07
July-December.....	5.00	9.25	7.30	9.00	18.50	12.68	8.20	11.15	9.32	8.20	11.25	.....	1.40	2.70	2.16	3.50	7.25	5.03	3.20	6.50	4.72	3.25	7.00	5.20
1915.																								
January-June.....	6.50	9.65	8.01	7.00	14.75	10.81	7.25	9.55	8.18	7.85	9.60	\$8.52	2.00	3.60	2.84	4.00	7.00	5.63	4.50	7.00	5.51	3.00	7.00	.....
July-December.....	6.50	12.20	8.86	7.00	20.50	13.12	7.40	13.10	10.42	7.70	12.55	10.62	1.90	3.75	2.75	4.50	8.00	6.11	4.50	8.00	6.05	3.00	7.50	.....
1916.																								
January-June.....	6.50	11.50	8.69	6.00	22.00	12.54	8.30	13.65	10.64	8.75	13.25	10.70	1.80	3.30	2.54	4.00	8.50	6.30	4.00	8.50	6.28	3.75	7.50	6.10
July-December.....	6.50	10.00	8.57	6.00	18.00	12.62	8.40	11.15	9.94	8.60	11.00	9.88	1.20	2.80	1.69	3.00	7.50	4.45	3.50	8.00	4.96	3.00	6.80	4.63
1917.																								
January-June.....	8.00	11.00	9.58	12.00	19.90	15.13	10.00	11.98	11.05	10.60	11.80	10.98	1.30	3.35	2.19	3.00	8.40	5.06	4.00	8.40	6.02	3.50	7.60	5.46
July-December.....	9.20	16.00	11.77	12.00	28.00	20.62	10.95	16.35	13.74	10.80	10.50	13.86	2.50	3.50	2.88	4.00	8.50	6.45	6.25	8.50	7.35	6.00	8.25	7.12
1918.																								
January-June.....	11.00	19.75	15.43	18.00	35.00	24.75	13.00	20.80	18.80	16.00	20.65	18.98	2.50	3.70	3.14	5.00	8.25	6.51	5.00	8.25	6.52	6.50	7.88	7.22
July-December.....	11.00	22.00	17.11	15.00	38.00	29.77	15.50	26.00	21.48	16.00	25.75	21.27	2.90	5.00	4.00	5.00	11.00	8.17	5.00	11.00	8.19	6.50	10.50	9.02
1919.																								
January.....	19.00	22.00	20.50	25.00	36.00	30.50	24.10	25.65	25.05	24.00	25.25	24.95	4.00	4.50	4.25	7.00	11.00	9.11	7.00	11.00	9.09	8.50	10.25	9.58
February.....	10.00	23.00	19.62	24.00	36.00	30.04	22.30	25.50	24.18	23.25	25.25	24.63	3.00	4.25	3.93	6.00	10.00	8.33	6.00	10.00	8.36	7.50	9.50	8.64
March.....	18.00	23.00	20.62	25.00	45.00	33.88	25.50	31.25	27.94	25.00	29.50	27.27	3.60	4.75	4.28	7.00	10.50	8.64	7.00	10.50	8.66	8.40	9.25	9.02
April.....	20.00	26.00	23.12	25.00	45.00	37.26	29.00	33.00	30.06	29.50	29.50	29.50	4.00	4.50	4.28	7.50	11.00	9.36	7.00	11.00	9.21	8.75	11.00	9.95

Statistics of Clover and Timothy Seed.

## CLOVER AND TIMOTHY SEED—Continued.

TABLE 122.—Clover and timothy seed: Wholesale price, 1913-1919—Continued.

Date.	Clover (bushels of 60 pounds).												Timothy.														
	Cincinnati.			Chicago.			Toledo.			Detroit.			Cincinnati.			Chicago.			Milwaukee.			St. Louis.					
	Prime.			Poor to prime.			Poor to choice.			All grades.			Per bushel (45 pounds).			Poor to choice (per 100 pounds).			Per 100 pounds.			Poor to prime (per 100 pounds).					
	Low.	High.	Average.	Low.	High.	Average.	Low.	High.	Average.	Low.	High.	Average.	Low.	High.	Average.	Low.	High.	Average.	Low.	High.	Average.	Low.	High.	Average.	Low.	High.	Average.
1919.																											
May.....	20.00	24.00	22.00	25.00	40.00	32.31	22.00	28.00	26.68	26.00	29.50	26.68	4.25	4.90	4.60	8.00	12.00	10.00	8.00	12.00	9.92	10.85	11.35	11.09			
June.....	19.00	22.00	20.37	25.00	40.00	32.50	22.00	27.50	26.42	27.00	27.00	27.00	4.50	4.80	4.68	9.00	12.00	10.50	9.00	12.00	10.50	11.00	11.35	11.06			
January-June....	10.00	26.00	21.04	24.00	45.00	32.75	22.00	33.00	26.72	23.25	29.50	26.67	3.60	4.90	4.34	6.00	12.00	9.32	6.00	12.00	9.29	7.50	11.35	9.89			
July.....	19.00	25.00	21.50	25.00	40.00	32.50	27.75	29.50	28.44	27.00	29.50	28.36	4.60	5.00	4.77	9.00	12.00	10.42	9.00	12.00	10.42	11.00	12.50	11.36			
August.....	22.00	28.00	24.00	25.00	45.00	35.31	29.50	30.50	29.99	29.50	30.00	29.59	4.50	5.25	5.50	9.00	12.00	10.41	9.00	12.00	10.36	10.00	12.00	11.55			
September.....	23.00	28.00	25.50	30.00	45.00	37.94	27.90	29.85	29.32	28.00	29.50	29.09	4.50	5.25	4.88	8.50	11.50	9.84	8.50	11.75	9.86	10.00	12.00	10.77			
October.....	23.00	29.00	25.38	30.00	48.00	38.60	30.00	31.70	31.01	29.50	31.00	30.45	4.25	4.75	4.38	8.50	11.25	9.88	8.50	11.25	9.88	10.00	11.25	10.25			
November.....	24.00	29.00	26.50	30.00	48.00	37.92	29.55	30.60	30.20	29.50	30.00	29.96	4.25	4.30	4.28	8.00	11.50	9.82	8.00	11.50	9.81	11.00	11.25	11.05			
December.....	25.00	30.00	27.50	30.00	48.00	39.00	30.35	31.45	30.76	30.00	31.00	30.53	4.25	4.30	4.28	8.50	12.50	10.08	8.50	12.25	10.05	11.00	11.25	11.06			
July-December...	19.00	30.00	25.06	25.00	48.00	36.88	27.75	31.70	29.95	27.00	31.00	29.66	4.25	5.25	4.68	8.00	12.50	10.08	8.00	12.25	10.06	10.00	12.50	11.01			

COTTON.

TABLE 123.—Cotton: Area and production in undermentioned countries, 1909–1918.

[Bales of 478 pounds net.]

Country.	Area.				Production.			
	Average 1909– 1913. <sup>1</sup>	1916	1917	1918	Average 1909– 1913. <sup>1</sup>	1916	1917	1918
<b>NORTH AMERICA.</b>								
	<i>Acres.</i>	<i>Acres.</i>	<i>Acres.</i>	<i>Acres.</i>	<i>Bales.</i>	<i>Bales.</i>	<i>Bales.</i>	<i>Bales.</i>
United States <sup>2</sup> .....	35,805,667	34,985,000	33,841,000	35,890,000	13,033,137	11,450,000	11,302,000	12,041,000
Porto Rico <sup>3</sup> .....	(4)	(4)	(4)	(4)	396	379	268	443
St. Croix.....	(4)	(4)	29	(4)	510	(4)	16	(4)
West Indies:								
British—								
Barbados <sup>5</sup> .....	4,227	(4)	(4)	(4)	1,211	299	124	(4)
Grenada.....	(4)	(4)	(4)	(4)	6,688	730	(4)	505
Jamaica <sup>5</sup> .....	(4)	602	45	(4)	66	(4)	(4)	(4)
Leeward Islands.....	(4)	(4)	(4)	(4)	2,254	(4)	(4)	(4)
St. Lucia <sup>5</sup> .....	(4)	(4)	(4)	(4)	15	(4)	(4)	(4)
St. Vincent <sup>5</sup> .....	5,045	2,622	2,401	(4)	903	618	335	(4)
Dominican Rep.....	(4)	(4)	(4)	(4)	1,140	270	(4)	(4)
Mexico.....	(4)	(4)	(4)	(4)	(4)	(4)	(4)	365,709
<b>SOUTH AMERICA.</b>								
Argentina.....	5,356	9,118	(4)	(4)	2,646	(4)	(4)	(4)
Brazil.....	(4)	(4)	(4)	(4)	290,400	420,000	449,000	(4)
Peru <sup>5</sup> .....	(4)	137,474	(4)	(4)	87,120	113,472	80,140	(4)
<b>EUROPE.</b>								
Bulgaria <sup>4</sup> .....	1,829	(4)	(4)	(4)	871	(4)	(4)	(4)
Malta.....	1,095	817	(4)	(4)	433	331	(4)	(4)
<b>ASIA.</b>								
British India.....	22,079,666	21,745,000	25,188,000	20,497,000	3,511,684	3,767,000	3,347,000	3,071,967
Ceylon.....	(4)	(4)	(4)	(4)	634	(4)	(4)	(4)
Cyprus.....	(4)	(4)	(4)	(4)	6,611	(4)	(4)	(4)
Dutch East Indies.....	(4)	(4)	(4)	(4)	15,121	(4)	(4)	(4)
Indo-China <sup>5</sup> .....	(4)	(4)	(4)	(4)	11,689	(4)	(4)	(4)
Japanese Empire:								
Japan.....	6,599	5,685	5,866	6,563	4,704	4,360	4,186	(4)
Korea.....	131,104	(4)	(4)	(4)	38,037	28,901	52,189	(4)
Russia:								
Transcaucasia <sup>6</sup> .....	252,637	233,254	-----	-----	79,885	-----	-----	-----
Central Asia <sup>6</sup> .....	1,123,433	1,900,349	1,147,000	-----	658,089	1,101,489	-----	-----
Siam.....	(4)	(4)	(4)	(4)	5,386	(4)	(4)	(4)
<b>AFRICA.</b>								
British Africa:								
Lagos.....	(4)	(4)	(4)	(4)	(4)	7,782	6,527	2,510
Nyasaland.....	23,534	29,850	(4)	(4)	4,001	7,244	5,439	4,184
East Africa.....	(4)	(4)	(4)	(4)	435	167	167	167
Gold Coast.....	(4)	(4)	(4)	(4)	34	80	83	83
Nigeria, N.....	(4)	(4)	(4)	(4)	8,570	9,038	3,264	2,510
Nigeria, S.....	(4)	(4)	(4)	(4)	(4)	84	84	(4)
Uganda.....	(4)	92,127	129,833	(4)	17,613	21,004	7,20,084	7,19,247
Union of S. Africa.....	(4)	(4)	(4)	(4)	94	6,267	732	837
Egypt.....	1,783,911	1,719,000	1,741,000	1,366,000	1,451,621	1,062,000	1,347,000	1,262,000
French Africa:								
Dahomey <sup>5</sup> .....	(4)	(4)	(4)	(4)	629	(4)	(4)	(4)
Guinea.....	(4)	(4)	(4)	(4)	230	(4)	(4)	(4)
Ivory Coast <sup>5</sup> .....	(4)	(4)	(4)	(4)	84	(4)	(4)	(4)
German Africa: <sup>6</sup>								
East Africa.....	35,643	(4)	(4)	(4)	5,807	(4)	(4)	(4)
Togo.....	(4)	(4)	(4)	(4)	2,350	(4)	(4)	(4)
Italian Africa:								
Entrea <sup>5</sup> .....	(4)	(4)	(4)	(4)	942	(4)	(4)	(4)
Sudan (Anglo-Egyptian).....	(4)	(4)	(4)	(4)	13,342	13,556	19,247	10,042
<b>OCEANIA.</b>								
British:								
Fiji.....	16	(4)	(4)	(4)	4	(4)	(4)	(4)
Queensland.....	523	(4)	(4)	(4)	91	(4)	(4)	(4)
Solomon Islands.....	(4)	(4)	(4)	(4)	22	(4)	(4)	(4)
French:								
New Caledonia <sup>5</sup> .....	(4)	(4)	(4)	(4)	463	(4)	(4)	(4)

<sup>1</sup> Five-year average except where statistics were not available.

<sup>2</sup> Linters not included. Quantity of linters produced 1,330,714 bales in 1916, 1,130,997 bales in 1917.

<sup>3</sup> Shipments to the United States plus exports to foreign countries.

<sup>4</sup> No official statistics.

<sup>5</sup> Exports.

<sup>6</sup> Old boundaries.

<sup>7</sup> Includes Rhodesia.

COTTON—Continued.

TABLE 124.—Cotton: Total production of countries for which estimates were available, 1900-1915.

Year.	Production.	Year.	Production.	Year.	Production.	Year.	Production.
	<i>Bales.<sup>1</sup></i>		<i>Bales.<sup>1</sup></i>		<i>Bales.<sup>1</sup></i>		<i>Bales.<sup>1</sup></i>
1900.....	15,893,591	1904.....	21,005,175	1908.....	23,888,292	1912.....	19,578,095
1901.....	15,920,048	1905.....	18,342,075	1909.....	20,679,334	1913.....	21,271,902
1902.....	17,331,503	1906.....	22,183,148	1910.....	22,433,269	1914.....	23,804,422
1903.....	17,278,881	1907.....	18,328,613	1911.....	21,754,810	1915.....	17,659,126

<sup>1</sup> Bales of 478 pounds, net weight.

TABLE 125.—Cotton: Acreage, production, value, exports, etc., in the United States, 1866-1919.

Year.	Acreage.	Average yield per acre.	Production.	Average farm price per pound Dec. 1.	Farm value Dec. 1.	New York closing prices, per pound, on middling upland.				Domestic exports, fiscal year beginning July 1.
						December.		May of following year.		
						Low.	High.	Low.	High.	
	<i>Acres.</i>	<i>Pounds.</i>	<i>Bales.</i>	<i>Cents.</i>	<i>Dollars.</i>	<i>Cents.</i>	<i>Cents.</i>	<i>Cents.</i>	<i>Cents.</i>	<i>Bales.<sup>1</sup></i>
1866....	7,599,000	129.0	1,750,000	.....	.....	33½	34½	27½	28½	1,322,947
1867....	7,828,000	189.8	2,340,000	.....	.....	15½	17½	30½	32½	1,569,527
1868....	6,799,000	192.2	2,380,000	.....	.....	24½	25½	28½	28½	1,288,656
1869....	7,743,000	196.9	3,012,000	.....	.....	25	25½	22½	23½	1,917,117
1870....	8,885,000	198.9	3,800,000	.....	.....	15	15½	14½	17½	2,925,856
1871....	7,558,000	148.2	2,553,000	.....	.....	19½	20½	23½	26½	1,867,075
1872....	8,483,000	188.7	3,920,000	.....	.....	19½	20½	19½	19½	2,400,127
1873....	9,510,000	179.7	3,683,000	.....	.....	15½	16½	17½	18½	2,717,205
1874....	11,764,000	147.5	3,941,000	.....	.....	14½	14½	16½	16½	2,520,838
1875....	11,934,000	190.6	5,123,000	.....	.....	13½	13½	11½	13½	2,982,811
1876....	11,677,000	167.8	4,438,000	9.0	174,724,000	12½	12½	10½	11½	2,890,738
1877....	12,133,000	163.8	4,370,000	.....	.....	11½	11½	10½	11½	3,215,067
1878....	12,344,000	191.2	5,244,000	8.2	192,515,000	8½	9½	11½	13½	3,256,746
1879....	14,480,000	181.0	5,755,000	10.3	269,305,000	12½	13½	11½	11½	3,644,363
1880....	15,951,000	184.5	6,343,000	9.8	289,083,000	11½	12	10½	10½	4,382,009
1881....	16,711,000	149.8	5,456,000	.....	.....	11½	12½	12½	12½	3,480,792
1882....	16,277,000	185.7	6,957,000	9.1	275,513,000	10½	10½	10½	11½	4,576,378
1883....	16,778,000	164.8	5,701,000	9.1	250,977,000	10½	10½	11½	11½	3,725,145
1884....	17,440,000	153.8	5,682,000	9.2	246,575,000	10½	11½	10½	11	3,783,319
1885....	18,301,000	164.4	6,575,000	8.4	251,775,000	9½	9½	9½	9½	4,116,149
1886....	18,455,000	160.5	6,446,000	8.1	251,856,000	9½	9½	10½	11½	4,338,915
1887....	18,641,000	182.7	7,020,000	8.5	290,901,000	10½	10½	9½	10½	4,528,883
1888....	19,059,000	180.4	6,941,000	8.5	292,139,000	9½	9½	11	11½	4,770,065
1889....	20,175,000	159.7	7,473,000	8.5	275,249,000	10½	10½	11½	12½	4,943,925
1890....	19,512,000	187.0	8,674,000	8.6	313,360,000	9½	9½	8½	8½	5,814,718
1891....	19,059,000	179.4	9,018,000	7.2	247,633,000	7½	8½	7½	7½	5,870,440
1892....	15,911,000	209.2	6,664,000	8.3	277,194,000	9½	10	7½	7½	4,424,230
1893....	19,525,000	149.0	7,493,000	7.0	204,983,000	7½	8½	7½	7½	5,266,505
1894....	23,688,000	195.3	9,476,000	4.6	212,335,000	5½	5½	6½	7½	7,034,866
1895....	20,185,000	155.6	7,161,000	7.6	238,503,000	8½	8½	8	8½	4,670,453
1896....	23,273,000	184.9	8,533,000	6.7	286,169,000	7½	7½	7½	7½	6,207,510
1897....	24,320,000	182.7	10,898,000	6.7	296,816,000	5½	5½	6½	6½	7,725,572
1898....	24,967,000	220.6	11,189,000	5.7	315,449,000	5½	5½	6½	6½	7,575,438
1899....	24,327,000	183.8	9,345,000	7.0	326,215,000	7½	7½	9	9½	6,252,451
1900....	24,933,000	194.4	10,123,000	9.2	463,310,000	9½	10½	8½	8½	6,718,125
1901....	26,774,000	170.0	9,510,000	7.0	334,088,000	8	8½	9½	9½	7,057,949
1902....	27,175,000	187.3	10,631,000	7.6	403,718,000	8½	8½	10.75	12.15	7,138,284
1903....	27,052,000	174.3	9,851,000	10.5	516,763,000	11.95	14.10	12.75	13.90	6,179,712
1904....	31,215,000	205.9	13,438,000	9.0	603,438,000	6.85	9.00	7.85	8.85	8,678,644
1905....	27,110,000	186.6	10,575,000	10.8	569,791,000	11.65	12.60	11.25	12.00	7,268,090
1906....	31,374,000	202.5	13,274,000	9.6	635,534,000	10.45	11.25	11.50	12.90	9,036,434
1907....	29,660,000	179.1	11,107,000	10.4	575,226,000	11.70	12.20	10.20	11.50	7,633,997
1908....	32,444,000	194.9	13,242,000	8.7	575,092,000	9.10	9.35	10.85	11.80	8,895,970
1909....	30,938,000	154.3	10,005,000	13.9	697,681,000	14.65	16.15	14.50	16.05	6,413,416
1910....	32,403,000	170.7	11,609,000	14.1	820,407,000	14.80	15.25	15.35	16.15	8,067,882
1911....	36,045,000	207.7	15,693,000	8.8	687,888,000	9.20	9.65	11.30	11.90	11,070,251
1912....	34,283,000	190.9	13,703,000	11.9	817,055,000	12.75	13.20	11.80	12.10	9,124,591
1913....	37,089,000	182.0	14,156,000	12.2	862,708,000	12.50	13.50	12.90	14.50	9,521,881
1914....	36,832,000	209.2	16,135,000	6.8	549,036,000	7.25	7.80	9.50	10.40	8,807,157
1915....	31,412,000	170.3	11,192,000	11.3	631,460,000	11.95	12.75	12.30	13.35	6,168,140
1916....	34,985,000	156.6	11,450,000	19.6	1,122,295,000	16.20	20.30	19.60	22.10	6,176,162
1917....	33,841,000	159.7	11,302,000	27.7	1,566,198,000	29.85	31.85	25.70	30.10	4,641,023
1918....	36,008,000	159.6	12,041,000	27.6	1,663,633,000	27.50	33.00	25.90	34.00	5,467,366
1919....	33,344,000	158.2	11,030,000	35.7	1,967,143,000	38.00	40.25	.....	.....	.....

<sup>1</sup> Bales of 500 pounds, gross weight.



COTTON—Continued.

TABLE 126.—Cotton: Acreage harvested, by States, 1910–1919.

[Thousands of acres.]

State.	1910	1911	1912	1913	1914	1915	1916	1917	1918	1919
Virginia.....	33	43	47	47	45	34	42	50	44	42
North Carolina.....	1,478	1,624	1,545	1,576	1,527	1,282	1,451	1,515	1,600	1,568
South Carolina.....	2,534	2,800	2,695	2,790	2,861	2,516	2,780	2,837	3,001	2,881
Georgia.....	4,873	5,504	5,335	5,318	5,433	4,825	5,277	5,195	5,341	5,288
Florida.....	257	308	224	188	221	193	191	183	167	117
Alabama.....	3,560	4,017	3,730	3,760	4,007	3,340	3,225	1,977	2,570	2,621
Mississippi.....	3,317	3,340	2,889	3,067	3,054	2,735	3,110	2,788	3,138	2,950
Louisiana.....	975	1,075	929	1,244	1,299	990	1,250	1,454	1,683	1,532
Texas.....	10,060	10,943	11,338	12,597	11,931	10,510	11,400	11,092	11,233	10,346
Arkansas.....	2,238	2,363	1,991	2,502	2,480	2,170	2,600	2,740	2,991	2,563
Tennessee.....	765	837	783	865	915	772	887	882	902	775
Missouri.....	100	129	103	112	145	96	133	153	148	111
Oklahoma.....	2,204	3,050	2,665	3,009	2,847	1,895	2,562	2,783	2,998	2,341
California.....	9	12	9	14	47	39	52	136	<sup>1</sup> 173	<sup>1</sup> 167
Arizona.....								41	95	116
All other.....					20	15	25	15	12	11
United States..	32,403	36,045	34,283	37,089	36,832	31,412	34,985	33,841	36,008	33,344

<sup>1</sup> Lower California (85,000 acres in 1919 and 88,000 acres in 1918) included in California figures but excluded from United States totals.

TABLE 127.—Cotton: Production of lint (excluding linters) in 500-pound gross weight bales, by States, 1910 to 1919.

[Thousands of bales, as finally reported by U. S. Bureau of the Census.]

State.	1910	1911	1912	1913	1914	1915	1916	1917	1918	1919
Virginia.....	15	30	24	23	25	16	27	19	25	22
North Carolina.....	706	1,076	866	792	931	699	655	618	898	875
South Carolina.....	1,164	1,649	1,182	1,378	1,534	1,134	932	1,237	1,570	1,475
Georgia.....	1,767	2,769	1,777	2,317	2,718	1,909	1,821	1,884	2,122	1,730
Florida.....	59	83	53	59	81	48	41	38	29	17
Alabama.....	1,194	1,716	1,342	1,495	1,751	1,021	533	518	801	715
Mississippi.....	1,263	1,204	1,046	1,311	1,246	954	812	905	1,226	946
Louisiana.....	246	385	376	444	449	341	443	639	588	300
Texas.....	3,049	4,256	4,880	3,945	4,592	3,227	3,726	3,125	2,697	2,700
Arkansas.....	821	939	792	1,073	1,016	816	1,134	974	987	830
Tennessee.....	332	450	277	379	384	303	382	240	330	298
Missouri.....	60	97	56	67	82	48	63	61	62	60
Oklahoma.....	923	1,022	1,021	840	1,262	640	823	959	577	930
California.....	6	10	8	23	50	29	44	58	67	<sup>1</sup> 102
Arizona.....								22	56	75
All other.....	4	7	3	10	14	7	14	5	6	7
United States..	11,609	15,693	13,703	14,156	16,135	11,192	11,450	11,302	12,041	11,030

<sup>1</sup> Includes 52,000 bales estimated grown in Lower California, not included in United States totals.

## COTTON—Continued.

TABLE 128.—Cotton: Condition of crop, United States, monthly, 1898-1919.

[Prior to 1901 figures of condition relate to first month following dates indicated.]

Year.	May 25.	June 25.	July 25.	Aug. 25.	Sept. 25.	Year.	May 25.	June 25.	July 25.	Aug. 25.	Sept. 25.
	<i>P. ct.</i>	<i>P. ct.</i>	<i>P. ct.</i>	<i>P. ct.</i>	<i>P. ct.</i>		<i>P. ct.</i>	<i>P. ct.</i>	<i>P. ct.</i>	<i>P. ct.</i>	<i>P. ct.</i>
1898.....	89.0	91.2	91.2	79.8	75.4	1909.....	81.1	74.6	71.9	63.7	58.5
1899.....	85.7	87.8	84.0	68.5	62.4	1910.....	82.0	80.7	75.5	72.1	65.9
1900.....	82.5	75.8	76.0	68.2	67.0	1911.....	87.8	88.2	89.1	73.2	71.1
1901.....	81.5	81.1	77.2	71.4	61.4	1912.....	78.9	80.4	76.5	74.8	69.6
1902.....	95.1	84.7	81.9	64.0	58.3	1913.....	79.1	81.8	79.6	68.2	64.1
1903.....	74.1	77.1	79.7	81.2	65.1	1914.....	74.3	79.6	76.4	78.0	73.5
1904.....	83.0	88.0	91.6	84.1	75.8	1915.....	80.0	80.2	75.4	69.2	60.8
1905.....	77.2	77.0	74.9	72.1	71.2	1916.....	77.5	81.1	72.3	61.2	56.3
1906.....	84.6	83.3	82.9	77.3	71.6	1917.....	69.5	70.3	70.3	67.8	60.4
1907.....	70.5	72.0	75.0	72.7	67.7	1918.....	82.3	85.8	73.6	55.7	54.4
1908.....	79.7	81.2	83.0	76.1	69.7	1919.....	75.6	70.0	67.1	61.4	54.4

TABLE 129.—Cotton: Yield per acre, price per pound Dec. 1, and value per acre, by States.

State.	Yield per acre (pounds of lint).											Farm price per pound (cents).					Value per acre (dollars). <sup>1</sup>		
	10-year average, 1910-1919.	1910	1911	1912	1913	1914	1915	1916	1917	1918	1919	10-year average, 1910-1919.	1915	1916	1917	1918	1919	5-year average, 1914-1918.	1919
Va....	253	212	330	250	240	265	225	310	180	270	250	17.5	11.4	19.4	27.8	26.5	35.0	45.34	87.50
N. C...	254	227	315	267	239	290	260	215	194	268	266	17.4	11.2	19.4	27.7	26.4	35.2	43.07	93.63
S. C...	227	216	280	209	235	255	215	160	208	250	243	17.8	11.3	19.6	28.4	27.6	35.7	40.27	86.75
Ga....	189	173	240	159	208	239	189	165	173	190	156	17.9	11.4	19.9	28.8	27.5	35.8	34.59	55.85
Fla....	116	110	130	113	150	175	120	105	100	85	70	25.9	14.8	31.0	50.5	43.0	42.0	31.74	29.40
Ala...	156	160	204	172	190	209	146	79	125	149	130	17.5	11.1	19.5	28.0	27.0	34.8	24.17	45.24
Miss..	171	182	172	173	204	195	167	125	155	187	154	18.1	11.5	20.5	28.5	27.8	37.5	30.84	57.75
La....	162	120	170	193	170	165	165	170	210	167	94	17.3	11.2	19.1	26.7	27.5	35.0	33.28	32.90
Tex...	155	145	186	206	150	184	147	157	135	115	125	17.3	11.1	19.4	26.7	28.2	35.0	25.55	43.75
Ark...	183	175	190	190	205	196	180	209	170	158	155	17.7	11.6	19.6	28.2	27.8	36.4	33.33	56.42
Tenn..	193	207	257	169	210	200	188	206	130	175	184	17.3	11.3	19.5	27.3	26.7	33.5	31.28	61.64
Mo....	258	285	360	260	286	270	240	225	190	200	260	17.0	11.0	19.0	27.5	27.0	34.0	38.59	88.40
Okla..	165	200	160	183	132	212	162	154	165	92	190	16.8	11.3	19.0	26.5	25.5	35.2	25.71	66.88
Calif..	376	335	390	450	500	500	380	400	242	270	292	18.6	11.2	20.0	28.0	30.0	43.0	61.26	125.56
Ariz...	292								285	280	310					48.0	51.0		158.10
U. S.	176.5	170.7	207.7	190.9	182.0	209.2	170.3	156.6	159.7	159.6	158.2	17.6	11.3	19.6	27.7	27.6	35.7	31.91	59.00

<sup>1</sup> Based upon farm price Dec. 1.

TABLE 130.—Cotton: Farm price, cents per pound on 1st of each month, 1909-1918.

Date.	1919	1918	1917	1916	1915	1914	1913	1912	1911	1910	Average.
Jan. 1.....	28.7	28.9	17.1	11.4	6.6	11.7	12.2	8.4	14.4	14.6	15.4
Feb. 1.....	24.9	29.7	16.8	11.5	7.4	11.9	11.9	9.0	14.3	14.0	15.1
Mar. 1.....	24.0	30.2	15.9	11.1	7.4	12.6	11.8	9.8	13.9	14.0	15.1
Apr. 1.....	24.5	31.8	18.0	11.5	8.1	11.9	11.8	10.1	13.9	14.1	15.6
May 1.....	26.0	28.5	18.9	11.5	9.1	12.2	11.6	10.9	14.2	14.0	15.7
June 1.....	29.5	27.4	20.2	12.2	8.6	12.4	11.5	11.0	14.6	14.2	16.2
July 1.....	31.1	28.6	24.7	12.5	8.6	12.4	11.0	11.2	14.4	13.9	16.9
Aug. 1.....	32.5	27.8	24.3	12.6	8.1	12.4	11.5	12.0	13.2	14.3	16.9
Sept. 1.....	30.3	32.2	23.4	14.6	8.5	8.7	11.8	11.3	11.8	14.4	16.7
Oct. 1.....	31.3	31.8	23.3	15.5	11.2	7.8	13.3	11.2	10.2	13.3	16.9
Nov. 1.....	36.5	29.3	27.3	18.0	11.6	6.3	13.0	10.9	8.9	14.0	17.6
Dec. 1.....	35.7	27.6	27.7	19.6	11.3	6.8	12.2	11.9	8.8	14.1	17.6
Average.....	31.4	29.4	22.7	15.1	9.7	9.1	12.4	10.5	11.4	14.0	16.6

TABLE 131.—Cotton: Closing price of middling upland, per pound, 1913-1919.

Date.	New York.			New Orleans.			Memphis.			Galveston.			Savannah.			Charleston.		
	Low.	High.	Average.	Low.	High.	Average.	Low.	High.	Average.	Low.	High.	Average.	Low.	High.	Average.	Low.	High.	Average.
1913.	<i>Cents.</i>	<i>Cents.</i>	<i>Cents.</i>	<i>Cents.</i>	<i>Cents.</i>	<i>Cents.</i>	<i>Cents.</i>	<i>Cents.</i>	<i>Cents.</i>	<i>Cents.</i>	<i>Cents.</i>	<i>Cents.</i>	<i>Cents.</i>	<i>Cents.</i>	<i>Cents.</i>	<i>Cents.</i>	<i>Cents.</i>	<i>Cents.</i>
January-June.....	11.70	13.40	12.50	12 $\frac{1}{8}$	13.00	12.46	12.00	13 $\frac{1}{8}$	12.45	12.00	13.00	12.30	11 $\frac{7}{8}$	12 $\frac{3}{8}$	12.30	11 $\frac{3}{8}$	12 $\frac{5}{8}$	12.11
July-December.....	11.90	14.50	13.11	11 $\frac{7}{8}$	14.00	12.92	11 $\frac{1}{4}$	13 $\frac{1}{4}$	12.93	11 $\frac{3}{8}$	14 $\frac{3}{8}$	13.01	11 $\frac{1}{2}$	14 $\frac{3}{8}$	12.71	12 $\frac{3}{8}$	13 $\frac{7}{8}$	13.18
1914.																		
January-June.....	12.30	14.50	13.16	12 $\frac{3}{8}$	13 $\frac{1}{2}$	13.17	13.00	13 $\frac{1}{2}$	13.32	12 $\frac{1}{2}$	14.00	13.12	12 $\frac{3}{8}$	13 $\frac{7}{8}$	13.13	12 $\frac{1}{4}$	13 $\frac{1}{2}$	12.92
July-December.....	7.25	13.25	9.46	6 $\frac{1}{2}$	13 $\frac{1}{8}$	8.67	6 $\frac{1}{2}$	13 $\frac{1}{4}$	8.63	6 $\frac{3}{8}$	13 $\frac{3}{8}$	8.78	6 $\frac{1}{2}$	13 $\frac{3}{8}$	8.59	6 $\frac{1}{2}$	8 $\frac{1}{2}$	7.25
1915.																		
January-June.....	7.90	10.60	9.27	7 $\frac{3}{8}$	9.68	8.64	7 $\frac{1}{8}$	9.50	8.55	7 $\frac{1}{2}$	10.10	8.92	7 $\frac{3}{8}$	9 $\frac{3}{8}$	8.69	7 $\frac{1}{2}$	9 $\frac{5}{8}$	8.46
July-December.....	8.90	12.75	11.01	8.50	12.13	10.69	8.62	12.25	10.60	8.50	12.60	10.74	8 $\frac{1}{2}$	12 $\frac{1}{2}$	10.54	9.00	12.00	10.85
1916.																		
January-June.....	11.20	13.45	12.31	11.13	13.06	12.08	11.38	13.25	12.30	11.45	13.75	12.52	11 $\frac{1}{2}$	13.00	12.19	11.00	12 $\frac{3}{4}$	11.94
July-December.....	12.90	20.95	16.61	13.00	20.38	16.27	13.12	20.50	16.59	13.65	20.85	16.64	13.00	20 $\frac{3}{8}$	16.54	12 $\frac{3}{8}$	20 $\frac{1}{2}$	16.42
1917.																		
January-June.....	14.30	27.40	19.72	16.50	26.25	19.36	17.00	26.00	19.55	14.50	26.50	19.48	18 $\frac{1}{4}$	26 $\frac{1}{4}$	20.22	17 $\frac{1}{4}$	26.00	20.04
July-December.....	21.20	31.85	27.22	20.13	30.13	26.01	22.00	30.00	26.79	21.20	30.35	26.38	20.00	30.00	26.26	20.00	30 $\frac{1}{4}$	25.76
1918.																		
January-June.....	25.70	36.00	31.26	28.50	34.50	31.22	29.00	34.50	31.47	27.25	34.75	31.18	29.00	34.50	31.62	28.50	34.00	31.58
July-December.....	27.50	38.20	32.28	27.80	34.50	30.60	29.00	35.00	31.08	26.75	36.35	31.55	28.25	35.25	30.62	27.00	35.00	30.30
1919.																		
January.....	25.60	32.40	29.10	27.00	30.75	28.84	28.00	30.50	29.29	28.25	31.75	29.45	30.00	31.00	30.88	30.00	30.00	30.00
February.....	25.00	27.85	26.25	25.50	27.75	26.98	26.50	28.00	27.18	28.25	28.25	28.25	27.00	20.00	27.68	25.00	30.00	26.91
March.....	26.10	28.60	27.68	25.25	27.50	26.40	26.50	27.25	26.86	25.75	28.25	26.93	27.00	27.25	27.04	25.00	26.75	25.99
April.....	28.60	29.65	28.85	25.25	27.75	26.70	26.50	28.00	26.90	26.00	29.00	27.15	26.25	28.00	26.93	26.00	27.50	26.14
May.....	25.90	34.00	30.43	27.63	32.38	29.34	28.00	32.00	29.20	29.00	33.50	30.60	27.50	32.50	29.23	27.00	31.00	28.55
June.....	30.35	34.95	32.99	31.00	33.00	32.10	31.50	32.75	32.19	31.50	34.20	32.93	30.50	33.50	31.90	30.25	32.90	31.68
January-June.....	25.00	34.95	29.22	25.25	33.00	28.39	26.50	32.75	28.60	25.75	34.20	29.22	26.25	33.50	28.94	25.00	32.90	28.21
July.....	33.40	36.20	35.25	33.00	34.50	33.91	32.75	34.50	33.81	33.50	35.50	34.59	32.50	34.50	33.58	32.00	34.00	33.08
August.....	30.55	35.10	32.10	30.13	34.25	31.40	32.50	34.50	33.52	30.50	35.00	31.91	30.00	33.50	31.50	30.50	34.00	32.02
September.....	28.85	32.85	30.60	29.00	32.50	30.41	30.00	32.50	30.94	29.50	35.00	31.56	27.75	32.00	29.60	28.00	31.75	29.36
October.....	31.10	38.40	34.98	31.75	29.00	35.29	32.50	40.00	35.91	33.75	40.50	37.10	32.00	37.38	34.56	31.50	37.00	32.72
November.....	38.40	40.50	39.12	38.75	41.75	39.58	40.00	43.00	41.12	40.00	43.00	41.28	37.25	39.44	36.80	37.00	38.88	37.74
December.....	38.00	40.25	38.84	39.25	40.00	39.88	39.50	40.50	39.93	38.25	42.75	41.68	38.00	39.75	38.45	38.00	39.00	38.48
July-December.....	28.85	40.50	35.15	29.00	41.75	35.08	30.00	43.00	35.87	29.50	43.00	36.35	27.75	39.75	34.09	28.00	39.00	33.90

154887°—YBK 1919—38

Statistics of Cotton.

## COTTON—Continued.

TABLE 132.—Cotton: International trade, calendar years 1909-1913, 1917, 1918.

[Expressed in bales of 500 pounds gross weight, or 478 pounds net. The figures for cotton refer to ginned and unginned cotton and linters, but not to mill waste, cotton batting, scarto (Egypt and Soudan). Wherever unginned cotton has been separately stated in the original reports it has been reduced to ginned cotton in this statement at the ratio of 3 pounds unginned to 1 pound ginned. See "General note," Table 101.]

## EXPORTS.

[000 omitted.]

Country.	Average 1909-1913.	1917 (prelim.).	1918 (prelim.).	Country.	Average 1909-1913.	1917 (prelim.).	1918 (prelim.).
<i>From—</i>	<i>Bales.</i>	<i>Bales.</i>	<i>Bales.</i>	<i>From—</i>	<i>Bales.</i>	<i>Bales.</i>	<i>Bales.</i>
Belgium.....	159			Netherlands.....	145		
Brazil.....	83	27	12	Persia <sup>1</sup> .....	118		
British India.....	1,966	1,663	819	Peru.....	87	80	99
China.....	240	232	360	United States.....	9,008	5,180	4,431
Egypt.....	1,442	844	1,040	Other countries.....	169		
France.....	316	89	29	Total.....	13,965		
Germany.....	232						

## IMPORTS.

<i>Into—</i>				<i>Into—</i>			
Austria-Hungary.....	906			Russia.....	886		
Belgium.....	496			Spain.....	382	447	277
Canada.....	137	178	230	Sweden.....	93	32	
France.....	1,435	1,260	656	Switzerland.....	113	94	38
Germany.....	2,258			United Kingdom.....	4,164	3,163	3,114
Italy.....	896	828	601	United States.....	215	290	236
Japan.....	1,405	1,947	1,886	Other countries.....	319		
Mexico.....	23			Total.....	14,005		
Netherlands.....	277						

<sup>1</sup> Year beginning Mar. 21.

## COTTONSEED.

TABLE 133.—Cottonseed: Production, by States, 1910-1919.

[Thousands of tons, 1910-1918, as reported by the United States Bureau of the Census.]

State.	1910	1911	1912	1913	1914	1915	1916	1917	1918	1919
Virginia.....	7	13	11	10	11	7	12	8	11	10
North Carolina.....	312	476	383	351	412	310	290	273	398	388
South Carolina.....	518	732	526	613	682	504	414	550	699	655
Georgia.....	795	1,246	798	1,038	1,217	860	826	847	947	769
Florida.....	33	46	28	31	43	27	26	25	17	7
Alabama.....	530	762	596	664	778	453	236	230	356	318
Mississippi.....	561	535	465	583	553	424	361	402	545	421
Louisiana.....	109	171	167	197	200	151	197	284	261	133
Texas.....	1,356	1,893	2,171	1,755	2,043	1,436	1,658	1,390	1,199	1,203
Arkansas.....	365	418	352	477	451	363	504	432	439	369
Tennessee.....	148	200	123	169	171	135	170	107	147	133
Missouri.....	26	43	25	30	36	21	28	27	28	27
Oklahoma.....	410	454	454	373	561	285	366	426	256	414
All other.....	5	8	5	14	28	16	25	39	57	82
United States.....	5,175	6,997	6,104	6,305	7,186	4,992	5,113	5,040	5,360	4,929

COTTONSEED—Continued.

TABLE 134.—Cottonseed: Value, by States, 1910-1919.

[Thousands of dollars.]

State.	1910	1911	1912	1913	1914	1915	1916	1917	1918	1919
Virginia.....	210	250	240	260	240	260	640	550	740	771
North Carolina.....	9,589	9,140	8,460	9,130	8,900	11,470	15,580	18,630	26,810	29,637
South Carolina.....	14,760	12,590	11,150	15,750	14,190	18,400	22,760	38,200	47,550	51,538
Georgia.....	22,580	21,060	16,360	25,120	24,580	31,730	45,980	58,660	64,170	61,204
Florida.....	990	800	490	650	740	850	1,240	1,600	1,130	545
Alabama.....	15,160	13,870	11,620	15,600	14,700	16,720	12,880	15,910	23,910	24,453
Mississippi.....	14,700	9,360	10,140	13,080	10,340	14,540	18,840	26,900	35,340	26,707
Louisiana.....	2,760	3,080	3,290	3,640	3,720	4,830	9,740	18,080	16,650	9,156
Texas.....	31,050	30,670	37,120	36,150	31,260	42,070	75,940	89,290	74,670	68,317
Arkansas.....	8,800	6,980	7,040	9,250	7,670	12,380	25,330	28,420	28,240	23,833
Tennessee.....	3,820	3,620	2,820	4,140	3,130	4,730	8,770	7,090	9,440	8,411
Missouri.....	660	980	550	640	790	660	1,460	1,730	1,760	1,992
Oklahoma.....	8,610	7,260	7,950	7,650	8,190	8,720	18,970	26,310	15,920	24,531
All other.....	130	140	100	310	500	540	940	2,180	3,160	5,656
United States.....	133,810	119,800	117,330	141,350	128,950	167,900	259,070	333,550	349,490	336,751

TABLE 135.—Cottonseed: Farm price per ton on 15th of each month, 1910-1919.

Date.	1919	1918	1917	1916	1915	1914	1913	1912	1911	1910
Jan. 15.....	\$64.93	\$67.51	\$52.53	\$36.85	\$19.14	\$22.70	\$21.98	\$16.57	\$26.35	.....
Feb. 15.....	64.65	66.95	51.43	36.75	23.33	23.37	22.01	16.81	25.61	.....
Mar. 15.....	64.00	68.27	53.18	36.56	22.32	23.60	21.55	18.21	25.49	.....
Apr. 15.....	64.28	68.08	55.94	38.13	22.69	24.17	21.89	18.62	26.12	.....
May 15.....	63.83	68.16	55.61	37.91	22.07	23.56	21.88	19.21	25.46	.....
June 15.....	63.80	66.03	57.19	35.79	20.82	23.62	21.54	19.24	23.38	.....
July 15.....	64.24	64.11	56.90	36.06	20.05	22.78	21.37	19.04	22.70	.....
Aug. 15.....	66.23	61.34	56.61	35.22	20.14	20.16	20.24	18.02	20.45	.....
Sept. 15.....	62.13	67.90	57.58	41.13	20.98	13.88	21.07	17.61	18.09	\$26.23
Oct. 15.....	66.95	65.85	65.02	47.19	33.73	15.28	22.01	18.04	16.73	26.86
Nov. 15.....	72.65	64.97	69.38	55.82	34.01	14.01	22.46	18.57	16.69	25.36
Dec. 15.....	69.07	65.05	68.29	56.35	35.54	17.73	23.48	21.42	16.70	25.65

COTTONSEED OIL.

TABLE 136.—Cottonseed oil: International trade, calendar years 1909-1913, 1917, 1918.

[See "General note," Table 101.]

EXPORTS.

[000 omitted.]

Country.	Average 1909-1913.	1917 (prelim.).	1918 (prelim.).	Country.	Average 1909-1913.	1917 (prelim.).	1918 (prelim.).
From—	Gallons.	Gallons.	Gallons.	From—	Gallons.	Gallons.	Gallons.
Belgium.....	1,086	.....	.....	United Kingdom...	7,139	649	15
China.....	281	1,388	2,369	United States.....	38,968	16,627	15,876
Egypt.....	476	648	127	Other countries....	44	.....	.....
France.....	335	16	6	Total.....	43,431	.....	.....
Netherlands.....	52	.....	.....				

IMPORTS.

Into—				Into—			
Algeria.....	364	.....	.....	Mexico.....	3,607	.....	.....
Australia.....	142	119	.....	Netherlands.....	5,352	.....	.....
Austria-Hungary...	39	.....	.....	Norway.....	1,504	3,658	.....
Belgium.....	2,251	.....	.....	Roumania.....	633	.....	.....
Brazil.....	624	47	.....	Senegal.....	422	.....	.....
Canada.....	2,817	5,246	6,255	Serbia.....	336	.....	.....
Egypt.....	257	( <sup>1</sup> )	.....	Sweden.....	696	.....	.....
France.....	3,289	1,999	479	United Kingdom...	5,899	2,564	5,727
Germany.....	6,918	.....	.....	Other countries....	4,191	.....	.....
Italy.....	4,600	71	4	Total.....	44,498	.....	.....
Malta.....	265	.....	.....				
Martinique.....	292	.....	.....				

<sup>1</sup> Year beginning Apr. 1.

<sup>2</sup> Less than 500 gallons.

## TOBACCO.

TABLE 137.—Tobacco: Area and production in undermentioned countries, 1909–1918.  
[000 omitted.]

Country.	Area.				Production.			
	Average 1909– 1913. <sup>1</sup>	1916	1917	1918	Average 1909– 1913. <sup>1</sup>	1916	1917	1918
NORTH AMERICA.								
United States.....	Acres. 1,148	Acres. 1,413	Acres. 1,518	Acres. 1,549	Pounds. 996,176	Pounds. 1,153,278	Pounds. 1,249,608	Pounds. 1,340,019
Porto Rico.....	18	13	( <sup>2</sup> )	( <sup>2</sup> )	12,700	<sup>3</sup> 9,409	<sup>3</sup> 17,114	.....
Canada:								
Quebec.....	10	3	5	( <sup>2</sup> )	6,262	3,000	5,000	( <sup>2</sup> )
Ontario.....	4	3	3	( <sup>2</sup> )	8,372	2,943	3,495	( <sup>2</sup> )
Total.....	14	6	8	.....	14,634	5,943	8,495	.....
Costa Rica.....	( <sup>2</sup> )	3	( <sup>2</sup> )	( <sup>2</sup> )	( <sup>2</sup> )	900	( <sup>2</sup> )	( <sup>2</sup> )
Cuba.....	( <sup>2</sup> )	( <sup>2</sup> )	( <sup>2</sup> )	( <sup>2</sup> )	57,490	( <sup>2</sup> )	( <sup>2</sup> )	( <sup>2</sup> )
Dominican Republic.....	( <sup>2</sup> )	( <sup>2</sup> )	( <sup>2</sup> )	( <sup>2</sup> )	29,200	17,250	28,750	<sup>4</sup> 35,000
Guatemala.....	( <sup>2</sup> )	( <sup>2</sup> )	( <sup>2</sup> )	( <sup>2</sup> )	674	862	( <sup>2</sup> )	( <sup>2</sup> )
Jamaica.....	1	1	1	( <sup>2</sup> )	418	( <sup>2</sup> )	( <sup>2</sup> )	( <sup>2</sup> )
Mexico.....	( <sup>2</sup> )	( <sup>2</sup> )	( <sup>2</sup> )	( <sup>2</sup> )	34,711	( <sup>2</sup> )	( <sup>2</sup> )	<sup>4</sup> 27,163
SOUTH AMERICA.								
Argentina.....	24	18	( <sup>2</sup> )	( <sup>2</sup> )	28,568	( <sup>2</sup> )	( <sup>2</sup> )	( <sup>2</sup> )
Brazil.....	( <sup>2</sup> )	( <sup>2</sup> )	( <sup>2</sup> )	( <sup>2</sup> )	59,991	<sup>5</sup> 47,636	<sup>5</sup> 56,789	( <sup>2</sup> )
Chile.....	2	( <sup>2</sup> )	( <sup>2</sup> )	( <sup>2</sup> )	3,377	( <sup>2</sup> )	( <sup>2</sup> )	( <sup>2</sup> )
Uruguay.....	3	1	1	( <sup>2</sup> )	2,371	884	558	( <sup>2</sup> )
Paraguay.....	( <sup>2</sup> )	( <sup>2</sup> )	( <sup>2</sup> )	( <sup>2</sup> )	13,000	20,000	( <sup>2</sup> )	( <sup>2</sup> )
EUROPE.								
Austria <sup>6</sup> .....	9	( <sup>2</sup> )	( <sup>2</sup> )	( <sup>2</sup> )	14,169	( <sup>2</sup> )	( <sup>2</sup> )	( <sup>2</sup> )
Hungary <sup>6</sup> .....	120	( <sup>2</sup> )	( <sup>2</sup> )	( <sup>2</sup> )	143,123	( <sup>2</sup> )	( <sup>2</sup> )	( <sup>2</sup> )
Croatia-Slavonia <sup>6</sup> .....	( <sup>2</sup> )	( <sup>2</sup> )	( <sup>2</sup> )	( <sup>2</sup> )	107	( <sup>2</sup> )	( <sup>2</sup> )	( <sup>2</sup> )
Bosnia-Herzegovina <sup>6</sup> .....	( <sup>2</sup> )	( <sup>2</sup> )	( <sup>2</sup> )	( <sup>2</sup> )	9,833	( <sup>2</sup> )	( <sup>2</sup> )	( <sup>2</sup> )
Belgium.....	10	( <sup>2</sup> )	( <sup>2</sup> )	( <sup>2</sup> )	20,741	( <sup>2</sup> )	( <sup>2</sup> )	( <sup>2</sup> )
Bulgaria <sup>6</sup> .....	24	( <sup>2</sup> )	( <sup>2</sup> )	( <sup>2</sup> )	15,220	( <sup>2</sup> )	( <sup>2</sup> )	( <sup>2</sup> )
Denmark.....	1	( <sup>7</sup> )	1	( <sup>2</sup> )	219	438	803	( <sup>2</sup> )
France <sup>6</sup> .....	39	22	14	11	45,272	32,280	17,142	( <sup>2</sup> )
Germany <sup>6</sup> .....	39	31	( <sup>2</sup> )	( <sup>2</sup> )	66,536	( <sup>2</sup> )	( <sup>2</sup> )	( <sup>2</sup> )
Greece.....	( <sup>2</sup> )	( <sup>2</sup> )	( <sup>2</sup> )	( <sup>2</sup> )	( <sup>2</sup> )	( <sup>2</sup> )	<sup>4</sup> 102,276	<sup>4</sup> 48,699
Italy.....	19	17	16	17	22,120	19,841	( <sup>2</sup> )	19,841
Netherlands.....	1	1	1	1	1,829	( <sup>2</sup> )	( <sup>2</sup> )	( <sup>2</sup> )
Roumania.....	<sup>6</sup> 25	<sup>6</sup> 24	( <sup>2</sup> )	<sup>8</sup> 31	<sup>6</sup> 16,426	( <sup>2</sup> )	( <sup>2</sup> )	<sup>8</sup> 13,481
Russia proper <sup>6</sup> .....	108	( <sup>2</sup> )	( <sup>2</sup> )	( <sup>2</sup> )	177,107	( <sup>2</sup> )	( <sup>2</sup> )	( <sup>2</sup> )
Poland <sup>6</sup> .....	( <sup>2</sup> )	( <sup>2</sup> )	( <sup>2</sup> )	( <sup>2</sup> )	( <sup>2</sup> )	( <sup>2</sup> )	( <sup>2</sup> )	( <sup>2</sup> )
Northern Caucasia <sup>6</sup> .....	64	( <sup>2</sup> )	( <sup>2</sup> )	( <sup>2</sup> )	55,842	( <sup>2</sup> )	( <sup>2</sup> )	( <sup>2</sup> )
Serbia <sup>6</sup> .....	5	( <sup>2</sup> )	( <sup>2</sup> )	( <sup>2</sup> )	3,988	( <sup>2</sup> )	( <sup>2</sup> )	( <sup>2</sup> )
Sweden.....	1	( <sup>2</sup> )	( <sup>2</sup> )	1	1,657	1,627	( <sup>2</sup> )	1,389
Switzerland.....	1	1	1	1	1,444	838	882	( <sup>2</sup> )
ASIA.								
British India.....	1,026	1,027	1,031	1,015	450,000	( <sup>2</sup> )	( <sup>2</sup> )	( <sup>2</sup> )
British North Borneo.....	( <sup>2</sup> )	( <sup>2</sup> )	( <sup>2</sup> )	( <sup>2</sup> )	2,891	( <sup>2</sup> )	( <sup>2</sup> )	( <sup>2</sup> )
Ceylon <sup>6</sup> .....	14	( <sup>2</sup> )	( <sup>2</sup> )	( <sup>2</sup> )	4,273	2,752	( <sup>2</sup> )	( <sup>2</sup> )
Dutch East Indies:								
Java and Madura.....	432	( <sup>2</sup> )	( <sup>2</sup> )	( <sup>2</sup> )	117,180	( <sup>2</sup> )	( <sup>2</sup> )	( <sup>2</sup> )
Sumatra, East Coast of.....	( <sup>2</sup> )	( <sup>2</sup> )	( <sup>2</sup> )	( <sup>2</sup> )	46,699	( <sup>2</sup> )	( <sup>2</sup> )	( <sup>2</sup> )
Japanese Empire:								
Japan.....	72	71	65	64	93,717	105,642	91,766	83,544
Korea.....	46	32	( <sup>2</sup> )	( <sup>2</sup> )	29,737	28,847	( <sup>2</sup> )	( <sup>2</sup> )
Formosa.....	1	3	( <sup>2</sup> )	( <sup>2</sup> )	1,120	3,737	( <sup>2</sup> )	( <sup>2</sup> )
Philippine Islands.....	155	146	153	( <sup>2</sup> )	63,907	90,695	107,868	( <sup>2</sup> )
Russia, Asiatic <sup>6</sup> .....	37	( <sup>2</sup> )	( <sup>2</sup> )	( <sup>2</sup> )	30,939	( <sup>2</sup> )	( <sup>2</sup> )	( <sup>2</sup> )
AFRICA.								
Algeria.....	21	( <sup>2</sup> )	25	27	23,974	( <sup>2</sup> )	36,155	52,910
Tunis.....	( <sup>2</sup> )	( <sup>2</sup> )	( <sup>2</sup> )	1	259	( <sup>2</sup> )	( <sup>2</sup> )	484
Nyasaland.....	7	9	7	( <sup>2</sup> )	2,416	<sup>5</sup> 3,706	<sup>5</sup> 4,304	( <sup>2</sup> )
Rhodesia.....	5	( <sup>2</sup> )	( <sup>2</sup> )	( <sup>2</sup> )	901	( <sup>2</sup> )	( <sup>2</sup> )	( <sup>2</sup> )
Union of South Africa.....	19	( <sup>2</sup> )	10	( <sup>2</sup> )	13,789	( <sup>2</sup> )	7,000	( <sup>2</sup> )
OCEANIA.								
Australia.....	2	2	1	( <sup>2</sup> )	1,837	1,302	( <sup>2</sup> )	( <sup>2</sup> )
Fiji.....	( <sup>2</sup> )	( <sup>2</sup> )	( <sup>2</sup> )	( <sup>2</sup> )	42	( <sup>2</sup> )	( <sup>2</sup> )	( <sup>2</sup> )

<sup>1</sup> Five-year average except where statistics were not available.<sup>2</sup> No official statistics.<sup>3</sup> Exports fiscal year beginning July 1.<sup>4</sup> Unofficial.<sup>5</sup> Exports.<sup>6</sup> Old boundaries.<sup>7</sup> Less than 500.<sup>8</sup> Including Bessarabia but excluding Dobrudja.

TOBACCO—Continued.

TABLE 138.—Tobacco: Total production of countries for which estimates were available, 1900–1915.

Year.	Production.	Year.	Production.	Year.	Production.	Year.	Production.
	<i>Pounds.</i>		<i>Pounds.</i>		<i>Pounds.</i>		<i>Pounds.</i>
1900.....	2,201,193,000	1904.....	2,146,641,000	1908.....	2,382,601,000	1912.....	1,274,319,000
1901.....	2,270,213,000	1905.....	2,279,728,000	1909.....	2,742,500,000	1913.....	2,149,258,000
1902.....	2,376,054,000	1906.....	2,270,298,000	1910.....	2,833,729,000	1914.....	2,254,687,000
1903.....	2,401,268,000	1907.....	2,391,061,000	1911.....	2,566,202,000	1915.....	2,153,395,000

TABLE 139.—Tobacco: Acreage, production, value, condition, etc., in the United States, 1849–1919.

NOTE.—Figures in *italics* are census returns; figures in roman are estimates of the Department of Agriculture. Estimates of acres are obtained by applying estimated percentages of increase or decrease to the published numbers of the preceding year, except that a revised base is used for applying percentage estimates whenever new census data are available.

Year.	Acreage (000 omitted).	Average yield per acre.	Production (000 omitted).	Average farm price per pound Dec. 1.	Farm value Dec. 1 (000 omitted).	Domestic exports of unmanufactured, fiscal year beginning July 1.	Imports of unmanufactured, fiscal year beginning July 1.	Condition of growing crop.			
								July 1.	Aug. 1.	Sept. 1.	When harvested.
	<i>Acres.</i>	<i>Lbs.</i>	<i>Pounds.</i>	<i>Cts.</i>	<i>Dolls.</i>	<i>Pounds.</i>	<i>Pounds.</i>	<i>P. ct.</i>	<i>P. ct.</i>	<i>P. ct.</i>	<i>P. ct.</i>
1849.....			199,753								
1859.....			434,209								
1869.....			262,735								
1879.....	639	739.7	472,661								
1889.....	695	702.5	488,257								
1899.....	1,101	788.5	868,113	7.2	62,104						
1900.....	1,046	778.0	814,345	6.6	53,661	315,787,782	26,851,253	88.5	82.9	77.5	76.1
1901.....	1,039	788.0	818,953	7.1	58,283	301,007,365	29,428,837	86.5	72.1	78.2	81.5
1902.....	1,031	797.3	821,824	7.0	57,564	368,184,084	34,016,956	85.6	81.2	81.5	84.1
1903.....	1,038	786.3	815,972	6.8	55,515	311,971,831	31,162,636	85.1	82.9	83.4	82.3
1904.....	806	819.0	660,461	8.1	53,383	334,302,091	33,288,378	85.3	83.9	83.7	85.6
1905.....	776	815.6	633,034	8.5	53,519	312,227,202	41,125,970	87.4	84.1	85.1	85.8
1906.....	796	857.2	682,429	10.0	68,233	340,742,864	40,898,807	86.7	87.2	86.2	84.6
1907.....	821	850.5	698,126	10.2	71,411	330,812,658	35,005,131	81.3	82.8	82.5	84.8
1908.....	875	820.2	718,061	10.3	74,130	287,900,946	43,123,196	86.6	85.8	84.3	84.1
1909.....	1,180	804.3	949,357								
1909.....	1,295	815.3	1,055,765	10.1	106,599	357,196,074	46,853,389	89.8	83.4	80.2	81.3
1910 <sup>1</sup> .....	1,366	807.7	1,103,415	9.3	102,142	355,327,072	48,203,288	85.3	78.5	77.7	80.2
1911.....	1,013	803.7	905,109	9.4	85,210	379,845,320	54,740,380	72.6	68.0	71.1	80.5
1912.....	1,226	785.5	962,855	10.8	104,063	418,796,906	67,977,118	87.7	82.8	81.1	81.8
1913.....	1,216	784.3	953,734	12.8	122,481	449,749,982	61,174,751	82.8	78.3	74.5	76.6
1914.....	1,224	845.7	1,034,679	9.8	101,411	348,346,091	45,764,728	66.0	66.5	71.4	81.8
1915.....	1,370	775.4	1,062,237	9.1	96,281	443,293,156	48,013,335	85.5	79.7	80.7	81.9
1916.....	1,413	816.0	1,153,278	14.7	169,672	411,598,860	46,136,347	87.6	84.4	85.5	85.6
1917.....	1,518	823.1	1,249,276	24.0	300,449	289,170,686	79,367,563	86.8	88.1	84.5	87.8
1918.....	1,647	873.7	1,439,071	28.0	402,264	629,519,583	83,951,103	83.1	83.6	82.4	87.4
1919.....	1,901	730.8	1,389,458	39.0	542,547			83.6	75.1	71.8	73.6

<sup>1</sup> Figures adjusted to census basis.

TABLE 140.—Tobacco: Acreage, production, and total farm value, by States, 1919.

State.	Acreage.	Production.	Farm value Dec. 1.	State.	Acreage.	Production.	Farm value Dec. 1.
	<i>Acres.</i>	<i>Pounds.</i>	<i>Dollars.</i>		<i>Acres.</i>	<i>Pounds.</i>	<i>Dollars.</i>
Massachusetts.....	10,000	15,400,000	7,130,000	Ohio.....	90,000	77,400,000	26,084,000
Connecticut.....	25,000	39,000,000	18,057,000	Indiana.....	17,900	15,215,000	5,356,000
New York.....	2,700	3,483,000	784,000	Illinois.....	700	525,000	105,000
Pennsylvania.....	41,000	54,120,000	9,200,000	Wisconsin.....	48,000	60,960,000	13,533,000
Maryland.....	29,000	19,575,000	5,872,000	Missouri.....	3,500	3,500,000	1,260,000
Virginia.....	230,000	131,100,000	62,141,000	Kentucky.....	550,000	456,500,000	174,383,000
West Virginia.....	15,000	10,500,000	5,250,000	Tennessee.....	110,000	88,000,000	22,088,000
N. Carolina.....	554,000	310,240,000	166,289,000	Alabama.....	3,000	1,890,000	567,000
S. Carolina.....	135,000	81,000,000	18,468,000	Louisiana.....	400	174,000	113,000
Georgia.....	31,000	16,430,000	3,532,000	Arkansas.....	800	456,000	160,000
Florida.....	4,200	3,990,000	2,175,000	U. S.....	1,901,200	1,389,458,000	542,547,000

TABLE 141.—Tobacco: Yield per acre, price per pound Dec. 1, and value per acre, by States.

State.	Yield per acre (pounds).											Farm price per pound (cents).					Value per acre (dollars). <sup>1</sup>		
	10-year average 1910-1919.	1910	1911	1912	1913	1914	1915	1916	1917	1918	1919	10-year average 1910-1919.	1915	1916	1917	1918	1919	5-year average 1914-1918.	1919
Massachusetts.....	1,558	1,730	1,650	1,700	1,550	1,750	1,100	1,660	1,400	1,500	1,540	26.2	14.5	25.0	38.4	40.0	46.3	464.37	713.02
Connecticut.....	1,582	1,730	1,625	1,700	1,550	1,770	1,350	1,630	1,400	1,500	1,560	27.3	17.0	27.0	38.4	44.0	46.3	438.93	722.28
New York.....	1,242	1,250	1,330	1,300	1,020	1,300	1,200	1,230	1,250	1,250	1,290	14.1	9.5	13.0	22.0	18.0	22.5	185.98	290.25
Pennsylvania.....	1,387	1,500	1,420	1,450	1,200	1,450	1,350	1,360	1,400	1,420	1,320	11.9	9.2	14.2	21.0	14.0	17.0	186.51	224.40
Maryland.....	743	690	735	660	740	800	740	770	780	830	675	14.5	8.5	16.0	20.0	30.0	30.0	131.42	202.50
Virginia.....	707	780	800	600	770	650	750	680	700	770	570	17.8	9.4	14.6	26.5	27.0	47.4	124.34	270.18
West Virginia.....	764	640	750	760	680	820	870	900	800	720	700	19.0	10.0	15.0	26.0	36.6	50.0	156.74	350.00
North Carolina.....	632	600	710	620	670	650	620	550	630	705	560	22.0	11.2	20.0	31.5	35.1	53.6	140.02	309.16
South Carolina.....	676	630	810	700	760	730	580	520	710	720	600	15.4	7.0	14.0	23.1	31.1	22.8	114.43	136.80
Georgia.....	880	680	900	830	1,000	1,000	880	1,180	1,000	800	530	30.8	23.0	27.0	57.0	46.0	21.5	341.68	113.95
Florida.....	959	680	940	840	1,000	1,000	910	1,210	1,100	960	950	35.2	23.0	30.0	57.0	46.0	54.5	388.18	517.75
Ohio.....	896	810	925	920	750	900	900	950	960	980	860	14.6	9.0	13.0	25.0	19.5	33.7	142.96	289.82
Indiana.....	874	880	910	800	750	900	840	930	950	930	850	14.2	7.3	13.0	20.0	20.7	35.2	129.15	299.20
Illinois.....	769	790	750	760	700	780	850	750	800	780	750	12.5	9.0	10.0	19.0	17.0	20.0	105.26	150.00
Wisconsin.....	1,172	1,050	1,250	1,290	1,180	1,180	900	1,270	1,000	1,330	1,270	13.2	6.0	12.5	17.5	22.0	22.2	162.03	281.94
Missouri.....	959	1,050	800	1,000	650	1,200	900	950	940	900	1,000	17.1	12.0	15.0	21.2	25.0	36.0	166.16	360.00
Kentucky.....	854	810	880	780	760	910	810	900	900	960	830	14.8	7.8	12.7	20.0	26.3	38.2	137.28	317.06
Tennessee.....	773	760	810	660	720	820	750	800	810	800	800	12.0	6.3	10.1	17.0	21.4	25.1	99.69	200.80
Alabama.....	621	500	700	750	700	700	500	300	730	700	630	28.0	22.0	30.0	35.0	30.0	30.0	172.30	189.00
Louisiana.....	422	550	450	300	450	400	420	450	350	420	434	36.9	30.0	28.0	35.0	63.0	65.0	157.30	282.10
Arkansas.....	623	650	600	650	650	610	600	500	700	700	570	20.1	17.0	20.0	23.2	25.0	35.0	129.84	199.50
United States.....	813.6	807.7	893.7	785.5	784.3	845.7	775.4	816.0	823.1	873.7	730.8	16.7	9.1	14.7	24.0	28.0	39.0	143.08	285.37

<sup>1</sup> Based upon farm price Dec. 1.



TOBACCO—Continued.

TABLE 142.—Tobacco: Acreage, production, and farm value, by types and districts, 1918 and 1919.

Type and district.	Acreage (thousands of acres).		Yield per-acre (pounds).		Production (thousands of pounds).		Average farm price per pound Dec. 1 (cents).		Total farm value (thousands of dollars). <sup>1</sup>	
	1919	1918	1919	1918	1919	1918	1919	1918	1919	1918
<b>I. CIGAR TYPES.</b>										
New England.....	35.0	35.0	1,554	1,500	54,400	52,500	46.3	42.9	25,187	22,500
New York.....	3.7	3.0	1,290	1,250	3,483	3,750	22.5	18.0	784	675
Pennsylvania.....	41.0	45.6	1,320	1,420	54,120	64,752	17.0	14.0	9,200	9,065
Ohio-Miami Valley.....	40.0	53.0	1,000	1,000	40,000	53,000	15.0	12.0	6,000	6,360
Wisconsin.....	48.0	49.0	1,270	1,330	60,960	65,170	22.2	22.0	13,533	14,337
Georgia and Florida.....	6.2	6.1	950	945	5,890	5,764	54.5	50.0	3,210	2,886
Total cigar types...	172.9	191.7	1,265	1,278	218,853	244,936	21.9	22.1	57,914	55,823
<b>II. CHEWING, SMOKING, SNUFF, AND EXPORT TYPES.</b>										
Burley.....	313.0	300.0	840	1,040	262,920	312,000	55.8	32.6	146,609	161,712
Paducah.....	137.8	95.0	800	800	110,240	76,000	24.0	21.0	26,458	15,960
Henderson.....	106.5	91.4	820	930	87,330	85,002	20.0	15.0	17,466	12,750
One-sucker.....	47.5	50.0	780	900	37,050	45,000	16.2	14.4	6,132	6,480
Clarksville and Hopkinsville.....	125.0	100.0	800	770	100,800	77,000	25.8	22.6	26,006	17,402
Virginia sun-cured.....	13.0	14.0	640	850	8,320	11,900	27.3	20.5	2,271	2,440
Virginia dark.....	70.0	70.0	680	860	47,600	60,200	30.0	17.7	14,280	10,655
Old Bright.....	395.0	320.0	510	710	201,450	227,200	56.6	34.4	114,020	75,885
New Bright.....	463.0	366.0	600	710	277,800	259,860	42.5	35.0	118,065	90,951
Maryland and eastern Ohio export.....	33.5	38.0	720	860	24,120	32,680	28.5	30.0	6,874	9,804
Louisiana Perique.....	.4	.3	434	420	174	126	65.0	65.0	113	82
Total chewing, smoking, snuff, and export types.	1,705.7	1,444.7	679	822	1,157,804	1,186,908	41.3	20.6	478,294	344,121
All other.....	22.6	10.7	566	670	12,801	7,167	41.7	32.2	6,339	2,320
Total.....	1,901.2	1,647.1	703.8	867.5	1,389,458	1,439,071	39.0	27.9	542,547	462,264

<sup>1</sup>Based upon farm price Dec. 1.

TABLE 143.—Tobacco: Price per pound, 1913-1919.

Date.	Cincinnati.			Hopkinsville.			Louisville.			Clarksville.			Richmond.			Baltimore.		
	Leaf, plug, stock, common to good red. <sup>1</sup>			Leaf, common to fine.			Leaf (burley, dark red), common to good.			Leaf, common to fine. <sup>2</sup>			Leaf, smokers, common to fine.			Leaf (Maryland), medium to fine.		
	Low.	High.	Average.	Low.	High.	Average.	Low.	High.	Average.	Low.	High.	Average.	Low.	High.	Average.	Low.	High.	Average.
1913.																		
January-June.....	5.50	13.75		7.00	14.00		7.00	14.00		9.00	14.00		6.00	16.00		8.50	15.00	
July-December.....	5.50	13.75		8.75	14.00		9.00	16.00		8.50	15.00		7.00	16.00		8.50	15.00	
1914.																		
January-June.....	5.50	14.00		8.00	14.00		9.00	16.00		9.50	16.00		7.00	20.00		8.50	15.00	
July-December.....	5.50	13.00		7.50	14.00		9.00	16.00		7.50	16.00		7.00	20.00		8.00	15.00	
1915.																		
January-June.....	6.00	13.00		4.00	12.50		8.00	14.00		6.00	13.00		7.00	20.00		8.00	13.00	
July-December.....	5.00	13.00		5.50	10.00		10.00	15.00		6.00	13.00		7.00	20.00		8.00	14.00	
1916.																		
January-June.....	5.00	16.00		5.00	14.00		10.00	16.00		4.50	13.00		7.00	20.00		9.00	16.00	
July-December.....	7.50	17.00		7.50	14.50		11.00	19.00		4.50	12.00		9.00	18.00		11.00	21.00	
1917.																		
January-June.....	15.00	21.00		10.00	19.00		13.00	20.00		8.00	14.50		9.00	27.00		17.00	24.00	
July-December.....	15.00	28.00		10.50	20.50		17.00	32.00		6.00	15.00		12.00	27.00		19.00	28.00	
1918.																		
January.....	22.00	40.00	28.25	14.00	23.50	18.10	25.00	44.00	29.09				<sup>3</sup> 21.00	<sup>3</sup> 30.00	<sup>3</sup> 24.97	22.00	39.00	27.10
July-December.....	22.00	40.00	31.00	14.50	25.00	19.96	30.00	44.00	39.58				16.00	45.00	32.50	33.00	49.00	40.03
1919.																		
January.....	32.00	50.00	43.00	15.00	35.00	23.75	28.00	42.00	38.62	10.00	30.00	17.31	16.00	45.00	30.50	33.00	40.00	36.50
February.....	32.00	50.00	43.00	17.00	34.50	25.84	30.00	48.00	37.38	10.00	31.00	20.50	16.00	45.00	30.50	33.00	40.00	36.50
March.....	32.00	50.00	43.00	18.00	36.50	26.12	18.00	48.00	35.12	10.00	35.00	28.28	16.00	45.00	30.50	33.00	40.00	36.50
April.....	32.00	50.00	43.00	18.00	30.00	23.94	17.00	35.00	26.00	10.00	29.50	19.31	15.00	45.00	28.25	33.00	40.00	36.50
May.....				18.00	29.50	23.19	15.00	35.00	24.50	10.00	24.50	16.56	15.00	37.00	26.00	31.00	40.00	35.50
June.....				( <sup>6</sup> )			15.00	25.00	20.33		( <sup>6</sup> )		15.00	37.00	26.00	31.00	38.00	34.50
January-June.....	32.00	50.00	43.00	15.00	36.50	24.57	15.00	48.00	30.32	10.00	35.00	20.39	15.00	45.00	28.62	31.00	40.00	36.00
July.....	15.00	45.00	26.00	( <sup>4</sup> )	( <sup>4</sup> )		15.00	25.00	20.00				15.00	37.00	26.00	26.00	38.00	32.00
August.....	15.00	45.00	26.00	( <sup>4</sup> )	( <sup>4</sup> )		13.00	25.00	18.62				15.00	37.00	26.00	35.00	42.50	37.00
September.....	15.00	45.00	36.00	( <sup>4</sup> )	( <sup>4</sup> )		16.50	26.00	21.38				15.00	37.00	25.00	36.00	48.00	40.62
October.....	15.00	45.00	26.00	( <sup>4</sup> )	( <sup>4</sup> )								15.00	37.00	26.00	31.00	48.00	39.50
November.....	15.00	45.00	26.00	( <sup>4</sup> )	( <sup>4</sup> )		10.00	30.00	23.67				15.00	37.00	26.00	31.00	50.00	39.50
December.....	15.00	45.00	26.00	12.14	28.25	19.23	16.00	45.00	30.50				15.00	37.00	26.00	31.00	53.00	42.00
July-December.....	15.00	45.00	26.00	12.14	28.25	19.23	10.00	45.00	22.83				15.00	37.00	26.00	26.00	53.00	38.44

<sup>1</sup> Burley, dark and bright red, common to good, February to December, 1917, inclusive and all of 1918 and 1919.

<sup>2</sup> No quotations for 1918.

<sup>3</sup> No grade given, five month average.

<sup>4</sup> Market closed.

<sup>5</sup> No quotations.

<sup>6</sup> Market closed.

TOBACCO—Continued.

TABLE 144.—Tobacco (unmanufactured): International trade, calendar years 1909–1913, 1917, 1918.

[Tobacco comprises leaf, stems, strippings, and tobacc, but not snuff. See "General note," Table 101.]

EXPORTS.

[000 omitted.]

Country.	Average 1909–1913.	1917 (prelim.).	1918 (prelim.).	Country.	Average 1909–1913.	1917 (prelim.).	1918 (prelim.).
<i>From—</i>	<i>Pounds.</i>	<i>Pounds.</i>	<i>Pounds.</i>	<i>From—</i>	<i>Pounds.</i>	<i>Pounds.</i>	<i>Pounds.</i>
Aden <sup>1</sup> .....	7,739	.....	.....	Mexico.....	1,845	.....	.....
Algeria.....	11,681	4,700	14,835	Netherlands.....	3,786	.....	.....
Austria-Hungary.....	23,192	.....	.....	Paraguay.....	11,361	.....	.....
Brazil.....	59,991	56,789	65,598	Persia <sup>2</sup> .....	3,874	.....	.....
British India.....	28,874	28,488	28,514	Philippine Islands....	26,018	15,134	56,705
Bulgaria.....	4,310	.....	.....	Russia.....	23,283	.....	.....
Ceylon.....	4,093	3,463	4,754	United States.....	381,127	251,863	406,827
Cuba.....	38,035	28,329	27,351	Other countries.....	94,995	.....	.....
Dominican Republic.....	22,395	19,294	33,510	<b>Total.....</b>	<b>928,535</b>	.....	.....
Dutch East Indies....	163,823	28,344	.....				
Greece.....	18,113	28,199	.....				

IMPORTS.

<i>Into—</i>				<i>Into—</i>			
Aden <sup>1</sup> .....	11,619	.....	.....	Italy.....	47,732	55,019	42,150
Argentina.....	14,988	27,378	12,454	Netherlands.....	57,218	.....	.....
Australia.....	13,740	5,707	.....	Norway.....	3,994	5,021	.....
Austria-Hungary.....	49,984	.....	.....	Portugal.....	6,565	.....	.....
Belgium.....	22,094	.....	.....	Nigeria.....	6,050	.....	.....
British India.....	6,538	8,129	5,775	Spain.....	51,026	41,342	49,807
Canada.....	17,891	18,570	22,870	Sweden.....	9,772	10,514	.....
China.....	15,113	20,524	24,145	Switzerland.....	17,949	17,551	13,866
Denmark.....	8,774	6,077	3,621	United Kingdom.....	117,956	44,359	171,428
Egypt.....	19,005	14,274	15,027	United States.....	52,768	57,960	83,514
Finland.....	9,597	.....	.....	Other countries.....	51,366	.....	.....
France.....	63,914	70,915	110,120	<b>Total.....</b>	<b>844,090</b>	.....	.....
Germany.....	168,437	.....	.....				

<sup>1</sup> Year beginning Apr. 1.

<sup>2</sup> Year beginning Mar. 21.

APPLES.

TABLE 145.—Apples: Production and prices, Dec. 1, by States, 1918 and 1919.

State.	Apples.							
	Total crop (000 omitted).				Commercial crop (000 omitted).			
	1919		1918		1919		1918	
	Price Dec. 1.		Per bushel.		Per barrel.			
	1919	1918	1919	1918	1919	1918	1919	1918
	<i>Bu.</i>	<i>Bu.</i>	<i>Bbls.</i>	<i>Bbls.</i>	<i>Dolls.</i>	<i>Dolls.</i>	<i>Dolls.</i>	<i>Dolls.</i>
Maine.....	4,680	2,010	601	226	1.17	0.95	3.45	2.80
New Hampshire.....	1,510	1,155	187	122	1.60	1.10	4.70	3.20
Vermont.....	1,500	990	203	105	1.75	1.40	4.90	4.10
Massachusetts.....	3,240	2,430	335	300	2.00	1.60	4.90	4.20
Rhode Island.....	294	189	24	20	1.95	1.55	5.50	4.60
Connecticut.....	1,572	999	119	108	1.70	1.55	5.00	3.90
New York.....	16,800	40,878	2,975	5,950	2.00	1.12	5.66	3.65
New Jersey.....	2,313	2,463	587	514	2.00	1.60	5.80	4.60
Pennsylvania.....	7,972	16,080	759	1,116	2.25	1.20	6.25	3.40
Delaware.....	750	714	192	186	2.00	1.25	6.00	4.50
Maryland.....	1,944	2,034	226	315	2.00	1.10	6.00	3.00
Virginia.....	9,950	10,068	1,508	1,766	1.60	1.24	5.25	3.95
West Virginia.....	3,478	5,856	648	1,092	1.80	1.17	5.65	3.55
North Carolina.....	1,108	3,588	92	184	1.87	1.30	6.16	4.20
South Carolina.....	700	1,407	.....	.....	2.80	2.05	7.35	5.70

## APPLES—Continued.

TABLE 145.—Apples: Production and prices, Dec. 1, by States, 1918 and 1919—Contd.

State.	Apples.							
	Total crop (000 omitted).		Commercial crop (000 omitted).		Price Dec. 1.			
					Per bushel.		Per barrel.	
	1919	1918	1919	1918	1919	1918	1919	1918
	Bu.	Bu.	Bbls.	Bbls.	Dolls.	Dolls.	Dolls.	Dolls.
Georgia.....	636	1,713	57	117	2.45	1.65	7.60	5.25
Ohio.....	2,806	7,005	364	902	2.62	1.53	7.50	4.64
Indiana.....	1,704	1,794	197	266	2.67	1.80	8.10	5.30
Illinois.....	4,943	3,459	750	837	2.30	1.85	7.00	6.00
Michigan.....	6,484	9,792	1,109	1,495	2.20	1.15	6.60	3.75
Wisconsin.....	2,087	2,811	126	114	2.20	1.55	6.30	4.80
Minnesota.....	1,365	996	61	49	2.50	2.09	7.40	6.11
Iowa.....	1,815	1,584	174	101	2.75	2.06	8.50	6.40
Missouri.....	5,773	4,245	1,127	735	1.90	1.64	5.70	5.10
South Dakota.....	302	273	3	3	3.00	2.35	9.00	6.80
Nebraska.....	1,125	525	215	72	2.50	2.30	8.00	7.00
Kansas.....	1,835	1,503	459	333	2.10	1.90	6.22	5.65
Kentucky.....	1,480	2,799	65	108	2.50	1.70	7.60	5.00
Tennessee.....	1,560	4,050	87	218	2.25	1.56	7.00	4.50
Alabama.....	617	1,662	10	26	2.50	1.70	7.50	6.00
Texas.....	624	273	40	11	1.90	1.60	6.00	4.50
Oklahoma.....	1,512	660	43	17	1.75	2.01	5.40	6.00
Arkansas.....	4,250	1,290	1,010	241	1.70	1.40	6.00	4.20
Montana.....	1,289	792	124	75	1.75	2.10	.....	.....
Colorado.....	3,418	2,067	828	527	1.85	1.70	.....	.....
New Mexico.....	1,329	912	224	117	2.00	1.18	.....	.....
Arizona.....	154	138	16	15	2.25	2.40	.....	.....
Utah.....	779	786	121	163	1.70	1.40	.....	.....
Idaho.....	4,350	1,200	1,200	112	1.80	1.70	.....	.....
Washington.....	23,190	16,491	6,440	4,296	1.55	1.25	.....	.....
Oregon.....	5,579	3,384	1,357	671	1.40	1.10	.....	.....
California.....	8,640	6,560	1,511	1,127	1.45	1.30	.....	.....
United States..	147,457	169,625	26,174	24,743	1.87	1.33	.....	.....

TABLE 146.—Apples: Total production (bushels) in the United States, 1889-1919.

Year.	Production.	Year.	Production.	Year.	Production.	Year.	Production.
1889 <sup>1</sup> .....	143,105,000	1897.....	163,728,000	1905.....	136,220,000	1913.....	145,410,000
1890.....	80,142,000	1898.....	118,061,000	1906.....	216,720,000	1914.....	253,200,000
1891.....	198,907,000	1899 <sup>1</sup> .....	175,397,000	1907.....	119,560,000	1915.....	230,011,000
1892.....	120,536,000	1900.....	205,930,000	1908.....	148,940,000	1916.....	193,905,000
1893.....	114,773,000	1901.....	135,500,000	1909 <sup>1</sup> .....	146,122,000	1917.....	166,749,000
1894.....	134,648,000	1902.....	212,330,000	1910.....	141,640,000	1918.....	169,625,000
1895.....	219,600,000	1903.....	195,680,000	1911.....	214,020,000	1919.....	147,457,000
1896.....	232,600,000	1904.....	233,630,000	1912.....	235,220,000		

<sup>1</sup> Census figures.

TABLE 147.—Apples: Farm price, cents per bushel on 1st of each month, 1910-1919.

Date.	1919	1918	1917	1916	1915	1914	1913	1912	1911	1910
Jan. 1.....	147.7	128.8	101.1	79.7	68.0	107.1	73.4	89.4	108.0	.....
Feb. 1.....	160.4	140.1	110.0	88.0	71.2	116.8	76.4	95.8	117.2	108.8
Mar. 1.....	175.4	145.3	123.3	92.0	73.2	126.0	80.4	101.2	121.6	112.6
Apr. 1.....	201.6	151.9	133.0	94.9	76.8	133.0	83.7	109.2	131.8	114.2
May 1.....	224.5	154.8	149.8	98.0	85.4	141.8	89.5	121.8	139.2	120.7
June 1.....	237.3	158.2	157.2	105.4	90.4	141.0	97.6	118.4	137.5	119.6
July 1.....	197.7	150.4	151.1	108.1	84.4	113.4	93.6	95.2	115.1	94.4
Aug. 1.....	174.7	128.1	127.0	80.4	70.1	79.9	80.6	75.0	83.9	75.4
Sept. 1.....	162.0	123.7	107.8	77.7	59.9	65.1	75.8	64.8	71.6	73.7
Oct. 1.....	171.1	133.5	106.8	83.1	62.0	58.8	81.0	61.8	68.0	75.5
Nov. 1.....	182.8	138.6	117.5	87.6	69.2	56.6	90.0	62.4	69.4	83.4
Dec. 1.....	186.8	132.8	121.5	91.2	69.0	59.4	98.1	66.3	72.1	89.6

APPLES—Continued.

TABLE 148.—Estimated annual production of the commercial apple crop in the United States for the years 1916 to 1919, inclusive.

[By commercial crop is meant that portion of the total crop which is sold for consumption as fresh fruit. One barrel is equivalent to three boxes.]

State.	1919	1918	1917	1916
	<i>Barrels.</i>	<i>Barrels.</i>	<i>Barrels.</i>	<i>Barrels.</i>
Maine.....	601,000	226,000	400,000	536,000
New Hampshire.....	187,000	122,000	120,000	198,000
Vermont.....	203,000	105,000	132,000	388,000
Massachusetts.....	335,000	300,000	225,000	368,000
Rhode Island.....	24,000	20,000	19,000	27,000
Connecticut.....	119,000	108,000	96,000	146,000
New York.....	2,975,000	5,950,000	2,058,000	5,544,000
New Jersey.....	587,000	514,000	408,000	462,000
Pennsylvania.....	759,000	1,116,000	854,000	1,225,000
Delaware.....	192,000	186,000	191,000	108,000
Maryland.....	226,000	315,000	263,000	311,000
Virginia.....	1,508,000	1,766,000	1,687,000	2,179,000
West Virginia.....	648,000	1,092,000	688,000	1,140,000
North Carolina.....	92,000	184,000	200,000	270,000
Georgia.....	57,000	117,000	120,000	111,000
Ohio.....	364,000	902,000	503,000	747,000
Indiana.....	197,000	266,000	456,000	298,000
Illinois.....	750,000	837,000	1,554,000	1,040,000
Michigan.....	1,109,000	1,495,000	515,000	1,414,000
Wisconsin.....	126,000	114,000	124,000	105,000
Minnesota.....	61,000	40,000	60,000	42,000
Iowa.....	174,000	101,000	275,000	180,000
Missouri.....	1,127,000	735,000	1,128,000	675,000
South Dakota.....	3,000	3,000	4,000	5,000
Nebraska.....	215,000	72,000	226,000	142,000
Kansas.....	459,000	333,000	650,000	560,000
Kentucky.....	65,000	108,000	153,000	135,000
Tennessee.....	87,000	218,000	192,000	147,000
Alabama.....	10,000	26,000	24,000	19,000
Texas.....	40,000	11,000	23,000	20,000
Oklahoma.....	43,000	17,000	54,000	27,000
Arkansas.....	1,010,000	241,000	409,000	245,000
Montana.....	124,000	75,000	74,000	70,000
Colorado.....	828,000	527,000	701,000	677,000
New Mexico.....	224,000	117,000	175,000	108,000
Arizona.....	16,000	15,000	16,000	17,000
Utah.....	121,000	163,000	184,000	24,000
Idaho.....	1,200,000	112,000	873,000	170,000
Washington.....	6,440,000	4,296,000	4,620,000	4,892,000
Oregon.....	1,357,000	671,000	713,000	801,000
California.....	1,511,000	1,127,000	1,174,000	1,174,000
United States.....	26,174,000	24,743,000	22,341,000	26,747,000

TABLE 149.—Estimated annual production by regions of the commercial apple crop in the United States, 1918 and 1919.

Region.	1918	1919	Region.	1918	1919
	<i>Barrels.<sup>1</sup></i>	<i>Barrels.<sup>1</sup></i>		<i>Barrels.<sup>1</sup></i>	<i>Barrels.<sup>1</sup></i>
Western New York.....	4,800,000	1,728,000	Southern and western Illi- nois.....	800,000	705,000
New England.....	645,000	1,120,000	Ozark.....	401,000	1,395,000
Hudson Valley.....	647,000	1,050,000	Arkansas River region.....	123,000	135,000
Shenandoah-Cumberland district.....	2,600,000	1,980,000	Missouri River region.....	630,000	990,000
Piedmont district.....	465,000	551,000	Pacific Northwest.....	5,037,000	9,128,000
South Ohio Rome Beauty district.....	558,000	184,000	Colorado.....	527,000	828,000
Western Michigan.....	760,000	912,000	California.....	1,127,000	1,511,000

<sup>1</sup> 1 barrel is equivalent to 3 boxes.

## APPLES—Continued.

TABLE 150.—Approximate relative production of principal varieties of apples, expressed as percentages of a normal crop of all apples.

Variety.	United States.	Maine.	New York.	Pennsylvania.	Virginia.	West Virginia.	Ohio.	Michigan.	Illinois.	Missouri.	Kentucky.	Arkansas.	Washington.	Oregon.	California.
	P. ct.	P. ct.	P. ct.	P. ct.	P. ct.	P. ct.	P. ct.	P. ct.	P. ct.	P. ct.	P. ct.	P. ct.	P. ct.	P. ct.	P. ct.
Arkansas (Mammoth Black Twig).....	0.7	0.2	.....	0.3	3.1	0.7	0.6	0.0	0.9	1.1	0.9	2.3	0.3	.....	0.3
Arkansas Black.....	.9	.....	.....	.2	.7	.8	.1	.....	.7	1.5	3.0	3.0	2.3	1.1	1.0
Baldwin.....	13.4	34.5	31.3	17.8	2.8	5.8	15.1	17.0	2.8	1.5	2.9	.4	7.8	12.6	3.2
Ben Davis.....	13.3	9.8	5.0	6.0	11.4	15.7	13.9	8.5	37.0	34.2	16.8	44.1	7.4	4.9	3.9
Early Harvest (Prince's Harvest).....	2.8	.9	.9	3.1	4.7	3.9	3.7	1.8	2.2	2.8	6.4	2.0	.8	.7	.7
Fall Pippin.....	1.7	.7	1.7	3.1	1.8	1.5	1.8	1.6	1.1	.4	2.4	.7	.8	.8	.6
Fameuse (Snow).....	1.3	3.5	2.4	.6	.1	.0	.6	3.0	1.5	.4	.0	.1	.3	.2	.0
Gano.....	1.6	.3	.2	.8	.6	1.6	1.3	.3	3.8	6.5	.2	6.6	.8	1.0	.2
Golden Russet.....	1.4	1.7	2.0	2.5	.3	1.6	.9	3.7	.7	.3	1.0	.1	.3	.6	.1
Gravenstein.....	1.1	2.3	.9	1.0	.1	.1	.3	.1	.1	.1	.0	.....	4.1	7.3	8.9
Grimes (Grimes Golden).....	2.2	.2	.1	2.6	2.6	4.6	5.0	1.2	4.9	3.6	2.6	2.1	1.6	.4	.1
Horse (Yellow Horse).....	.9	.....	.....	.....	1.0	.0	.0	.0	.2	.5	2.1	1.5	.....	.1	.....
Jonathan.....	3.6	.8	.4	1.4	1.0	1.7	1.8	2.2	9.3	10.4	2.5	3.7	13.8	4.4	1.7
Limburtwig (Red Limburtwig).....	1.6	.0	.0	.....	2.5	.8	.3	.0	.6	1.5	4.0	5.8	.....	.2	.3
McIntosh (McIntosh Red).....	.9	3.7	1.6	.7	.1	.1	.1	.3	.4	.1	.1	.1	.3	.1	.1
Maiden Blush.....	2.0	.3	1.0	3.0	1.5	2.5	4.5	2.6	2.3	2.8	4.5	1.0	.3	.2	.4
Missouri (Missouri Pippin).....	.8	.0	.0	.0	.2	.1	.1	.1	1.2	3.0	.5	1.4	.5	.1	.9
Northern Spy.....	6.1	7.1	13.1	11.4	.8	4.2	7.7	17.9	1.4	1.1	1.4	.5	3.8	7.4	.6
Northwestern Greening.....	.9	.3	.9	.4	.0	.4	.6	1.9	.3	.3	.4	.....	1.0	.1	.2
Oldenburg (Duchess of Oldenburg).....	1.9	2.9	2.2	1.1	.1	.5	1.0	5.0	1.7	.5	.1	.....	1.1	.3	.1
Red Astrachan.....	1.9	3.9	2.1	3.5	.8	2.1	2.7	2.8	.8	.8	.3	.5	1.7	2.2	3.3
Red June (Carolina Red June).....	1.6	.....	.7	.3	1.8	1.3	.2	.0	1.2	1.9	4.3	2.7	1.3	1.3	1.4
Rhode Island Greening.....	4.7	4.1	14.8	5.5	.3	1.4	5.7	5.4	.8	.3	.2	.6	2.2	2.6	2.7
Rome Beauty.....	3.1	.1	.3	2.1	1.2	18.7	10.8	.2	3.8	1.7	9.6	1.8	12.2	5.6	2.4
Stayman Winesap.....	1.5	.6	.1	1.8	5.3	1.9	1.3	.1	.5	1.8	1.9	1.7	2.7	1.8	.9
Tolman (Tolman Sweet).....	1.0	2.6	2.1	1.1	.1	.4	.5	2.4	.3	.2	.3	.....	.9	.....	.0
Tompkins King (King of Tompkins Co.).....	1.4	2.4	4.1	1.5	.0	.5	.6	2.1	.1	.1	.0	.....	2.7	5.1	1.1
Wealthy.....	2.2	5.4	1.8	1.2	.0	1.1	1.2	3.7	1.6	1.3	.4	.1	1.5	1.1	.1
White Pearmain (White Winter Pearmain).....	.5	.....	.1	.0	.2	.2	.1	.0	.2	.3	.3	.1	.6	.5	7.5
Winesap.....	5.1	.5	.1	1.8	20.7	1.8	1.8	.4	5.6	6.8	14.0	8.4	7.1	2.9	1.4
Wolf River.....	.9	1.4	.3	.3	.2	.6	.5	1.5	.4	.7	.3	.....	.8	1.7	.1
Yellow Bellflower.....	1.4	1.7	.3	2.3	.2	1.5	1.3	1.2	.5	1.0	.6	.1	1.9	3.4	18.6
Yellow Newtown (Albermarle; Newtown Pippin).....	1.6	.0	.2	.6	7.0	.3	.4	.3	.2	.1	.2	.....	2.9	11.3	28.7
Yellow Transparent.....	1.5	1.1	.3	1.7	1.5	3.2	2.1	1.4	2.1	1.1	3.2	.4	1.5	1.6	.2
York Imperial (Johnson Fine Winter).....	2.1	.....	.1	7.5	15.1	5.0	1.3	.3	.8	1.1	.1	.1	.2	.9	.1
Other varieties.....	10.4	7.0	8.9	12.8	10.2	13.4	10.1	11.0	7.4	8.2	12.5	8.2	12.5	15.5	8.2
Total.....	100.0	100.0	100.0	100.0	100.0	100.0	100.0	100.0	100.0	100.0	100.0	100.0	100.0	100.0	100.0

NOTE.—In important apple-producing States not included in table, the principal varieties and their respective percentages of all apples in a normal crop are:

*Indiana.*—Ben Davis 22.8, Baldwin 7.2, Grimes Golden 6.7, Winesap 6.7, Maiden Blush 5.8, Rome Beauty 4.4, Northern Spy 4.2. *North Carolina.*—Limburtwig 14.3, Winesap 12.2, Ben Davis 7.5, Early Harvest 7.2, Horse 7.2, Red June 5.9. *Tennessee.*—Winesap 14.1, Ben Davis 12.2, Limburtwig 12.1, Early Harvest 8.4, Horse 6.3, Red June 5.4. *Iowa.*—Ben Davis 15.2, Wealthy 12.4, Jonathan 10.3, Oldenburg 8.9, Grimes Golden 4.9, Northwestern Greening 4.3. *Kansas.*—Ben Davis 19.4, Winesap 15.3, Jonathan 13.8, Missouri Pippin 8.6, Gano 6.0, Maiden Blush 4.3. *Colorado.*—Ben Davis 26.3, Jonathan 18.3, Gano 7.8, Rome Beauty 4.8, Winesap 4.1. *Massachusetts.*—Baldwin 48.4, Rhode Island Greening 9.3, Gravenstein 5.7, McIntosh Red 5.7, Northern Spy 5.1. *Nebraska.*—Ben Davis 21.3, Winesap 13.6, Jonathan 9.4, Wealthy 6.2, Oldenburg 5.8, Grimes Golden 4.8, Missouri Pippin 4.2, Gano 4.0. *Wisconsin.*—Oldenburg 14.7, Wealthy 13.7, Northwestern Greening 11.1, Fameuse (Snow) 8.0, Wolf River 7.5, Ben Davis 5.1, Golden Russet 4.2. *Maryland.*—Ben Davis 17.0, York Imperial 16.2, Baldwin 8.8, Winesap 7.6, Stayman Winesap 7.0, Arkansas 4.4, Early Harvest 4.2. *New Jersey.*—Baldwin 25.2, Ben Davis 14.5, Rome Beauty 5.0, Early Harvest 4.7, Rhode Island Greening 4.3, Northern Spy 4.2. *Vermont.*—Baldwin 15.1, Rhode Island Greening 12.8, Northern Spy 12.0, Fameuse (Snow) 8.1, McIntosh 6.1, Ben Davis 5.6, Yellow Bellflower 4.2. *Connecticut.*—Baldwin 42.2, Rhode Island Greening 16.9, Golden Russet 5.2. *New Hampshire.*—Baldwin 51.9, Rhode Island Greening 5.9, Northern Spy 5.2, McIntosh 4.4. *Idaho.*—Jonathan 21.3, Rome Beauty 16.6, Ben Davis 13.1, Gano 7.8, Winesap 4.6. *Oklahoma.*—Ben Davis 25.8, Missouri Pippin 12.1, Jonathan 8.2, Winesap 8.1, Arkansas Black 5.6, Gano 4.0. *Georgia.*—Horse 14.3, Ben Davis 12.2, Red June 10.0, Limburtwig 8.8, Winesap 7.6, Early Harvest 6.1, Arkansas Black 1.6.

PEACHES.

TABLE 151.—Peaches: Production and prices, by States, 1918 and 1919.

State.	Total crop (000 omitted).		Commercial crop (000 omitted).		Prices.			
					1919		1918	
	1919	1918	1919	1918	Oct. 15.	Sept. 15.	Oct. 15.	Sept. 15.
	Bushels.	Bushels.	Bushels.	Bushels.	Dollars.	Dollars.	Dollars.	Dollars.
New Hampshire.....	43	0	11	0	.....	2.10	.....	.....
Massachusetts.....	160	0	49	0	2.40	2.20	.....	.....
Connecticut.....	200	0	53	0	.....	2.50	.....	.....
New York.....	1,648	700	780	525	3.00	2.70	3.75	3.10
New Jersey.....	1,018	832	683	640	2.60	2.70	2.60	2.80
Pennsylvania.....	1,200	720	467	258	3.00	3.00	2.60	2.75
Delaware.....	277	136	175	101	.....	1.90	.....	2.40
Maryland.....	731	235	287	144	.....	1.90	2.00	2.40
Virginia.....	928	510	201	90	2.20	2.00	2.50	1.80
West Virginia.....	760	680	529	459	2.50	2.20	2.45	1.80
North Carolina.....	713	1,150	92	90	2.50	2.10	1.85	1.60
South Carolina.....	466	928	35	102	2.80	2.20	.....	1.67
Georgia.....	5,895	6,092	2,964	3,255	2.30	2.50	1.65	1.50
Ohio.....	428	174	173	87	3.70	3.30	3.20	3.00
Indiana.....	150	0	14	0	3.40	3.30	3.00	3.40
Illinois.....	790	0	261	0	3.20	2.70	3.15	3.50
Michigan.....	480	85	120	54	3.10	3.10	3.35	3.30
Iowa.....	3	0	.....	.....	3.00	3.30	3.75	3.30
Missouri.....	828	0	139	0	2.00	2.00	2.10	3.30
Nebraska.....	0	0	.....	.....	.....	.....	.....	.....
Kansas.....	80	0	.....	.....	2.50	2.60	.....	3.50
Kentucky.....	726	110	15	4	2.40	2.40	1.00	2.75
Tennessee.....	978	833	119	100	2.20	1.80	1.70	1.70
Alabama.....	1,678	2,440	109	138	1.20	1.70	.....	1.10
Texas.....	2,760	2,333	880	767	2.00	1.80	2.00	1.75
Oklahoma.....	1,007	167	345	77	2.30	1.40	1.90	1.90
Arkansas.....	3,639	217	1,360	87	1.70	1.60	1.67	1.90
Colorado.....	840	959	676	719	2.50	2.50	.....	2.00
New Mexico.....	145	34	75	27	2.10	2.00	2.45	2.35
Utah.....	1,500	1,050	830	735	1.70	1.60	1.40	1.50
Idaho.....	350	51	163	42	2.10	1.80	.....	1.90
Washington.....	1,899	575	1,417	402	1.70	1.70	1.75	1.60
Oregon.....	514	93	171	31	1.40	1.40	2.00	2.00
California.....	17,600	11,920	16,268	11,663	1.90	1.50	1.45	1.40
United States..	50,434	33,094	29,461	20,597	2.12	1.91	1.93	1.62

TABLE 152.—Peaches: Total production (bushels) in the United States, 1899-1919.

Year.	Production.	Year.	Production.	Year.	Production.
1899 <sup>1</sup> .....	15,433,000	1906.....	44,104,000	1913.....	39,707,000
1900.....	49,438,000	1907.....	22,527,000	1914.....	54,109,000
1901.....	46,445,000	1908.....	48,145,000	1915.....	64,097,000
1902.....	37,831,000	1909 <sup>1</sup> .....	35,470,000	1916.....	37,505,000
1903.....	28,850,000	1910.....	48,171,000	1917.....	45,066,000
1904.....	41,070,000	1911.....	34,880,000	1918.....	33,094,000
1905.....	36,634,000	1912.....	52,343,000	1919.....	50,434,000

<sup>1</sup> Census figures.

## PEACHES—Continued.

TABLE 153.—*Peaches: Farm price, cents per bushel on 15th of month, 1910-1919.*

Date.	1919	1918	1917	1916	1915	1914	1913	1912	1911	1910
Apr. 15.....										
May 15.....									130.0	
June 15.....	191.1	134.0	170.3	119.6				119.2	152.0	
July 15.....	201.6	169.4	144.8	109.1	99.5	120.4	130.5	112.1	135.0	
Aug. 15.....	199.6	178.9	143.3	114.9	85.4	105.0	126.2	108.3	151.0	
Sept. 15.....	205.7	185.3	143.8	118.3	81.1	102.2	130.3	110.0	138.0	110.9
Oct. 15.....	211.7	193.2	160.6	112.1	85.2	105.3	145.0	105.0	129.0	115.1
Nov. 15.....									131.0	122.8
Dec. 15.....									125.0	
									142.0	

TABLE 154.—*Estimated production of the commercial peach crop, 1917 to 1919.*

State.	1919 (prelim.).	1918	1917	State.	1919 (prelim.).	1918	1917
	<i>Bushels.</i>	<i>Bushels.</i>	<i>Bushels.</i>		<i>Bushels.</i>	<i>Bushels.</i>	<i>Bushels.</i>
New Hampshire.....	11,000	0	14,000	Illinois.....	261,000	0	171,000
Massachusetts.....	49,000	0	36,000	Michigan.....	120,000	54,000	333,000
Connecticut.....	53,000	0	273,000	Missouri.....	139,000	0	218,000
New York.....	780,000	525,000	3,617,000	Kentucky.....	15,000	4,000	44,000
New Jersey.....	683,000	640,000	711,000	Tennessee.....	119,000	100,000	65,000
Pennsylvania.....	467,000	258,000	665,000	Alabama.....	109,000	138,000	69,000
Delaware.....	175,000	101,000	165,000	Texas.....	880,000	767,000	456,000
Maryland.....	287,000	144,000	639,000	Oklahoma.....	345,000	77,000	287,000
Virginia.....	201,000	90,000	119,000	Arkansas.....	1,360,000	87,000	849,000
West-Virginia.....	529,000	459,000	675,000	Colorado.....	676,000	719,000	822,000
North Carolina.....	92,000	90,000	150,000	New Mexico.....	75,000	27,000	99,000
South Carolina.....	35,000	102,000	113,000	Utah.....	830,000	735,000	956,000
Georgia.....	2,964,000	3,255,000	1,512,000	Idaho.....	163,000	42,000	158,000
Ohio.....	173,000	87,000	188,000	Washington.....	1,417,000	402,000	1,223,000
Indiana.....	14,000	0	31,000	Oregon.....	171,000	31,000	114,000
				California <sup>1</sup> .....	16,268,000	11,663,000	14,151,000
				United States.....	29,461,000	20,597,000	28,927,000

<sup>1</sup> Attention is called to the fact that approximately 90 per cent of the California peach crop is either canned or dried.



PEARS.

TABLE 155.—Pears: Production and prices, 1918 and 1919.

State.	Total crop (000 omitted).		Commercial crop (000 omitted).		Prices Nov. 15.	
	1919	1918	1919	1918	1919	1918
	<i>Bushels.</i>	<i>Bushels.</i>	<i>Bushels.</i>	<i>Bushels.</i>	<i>Dollars.</i>	<i>Dollars.</i>
Maine.....	44	20				
New Hampshire.....	25	15				
Vermont.....	18	13				
Massachusetts.....	115	77				
Rhode Island.....	12	10				1.75
Connecticut.....	47	34				1.75
New York.....	1,530	1,352	990	828	2.40	1.50
New Jersey.....	500	650	200	211	1.40	1.10
Pennsylvania.....	355	518			2.30	1.85
Delaware.....	200	238	144	296		.80
Maryland.....	420	455			1.30	1.00
Virginia.....	190	119			1.60	1.20
West Virginia.....	40	33			2.30	2.00
North Carolina.....	84	108			2.10	1.50
South Carolina.....	81	98			2.20	1.40
Georgia.....	152	188			1.80	1.50
Florida.....	70	132				
Ohio.....	218	304			2.60	1.70
Indiana.....	188	260			1.80	1.75
Illinois.....	436	302	150	104	1.70	1.60
Michigan.....	426	704	123	307	1.80	1.25
Iowa.....	58	32			1.90	
Missouri.....	280	112	38	24	1.40	1.90
Nebraska.....	16	6			2.50	
Kansas.....	120	38			1.70	2.60
Kentucky.....	128	140			1.80	1.75
Tennessee.....	72	112			2.00	1.50
Alabama.....	114	152			1.60	1.30
Mississippi.....	95	136			1.60	1.05
Louisiana.....	50	52				1.20
Texas.....	385	246	60	60	1.40	1.50
Oklahoma.....	70	38			1.90	2.40
Arkansas.....	98	64			1.70	1.80
Montana.....	11	6			3.00	
Colorado.....	290	194	392	182	2.20	1.50
New Mexico.....	67	56			2.30	
Arizona.....	22	19			3.80	3.84
Utah.....	47	51				1.60
Nevada.....	5	6				
Idaho.....	70	60				1.50
Washington.....	1,700	1,300	1,620	1,300	1.70	1.15
Oregon.....	553	672	615	406	1.50	1.25
California.....	4,500	4,240	4,090	3,871	1.80	1.40
United States.....	13,902	13,362	8,422	7,589	1.84	1.38

TABLE 156.—Pears: Total production (bushels) in the United States, 1909-1919.

Year.	Production.	Year.	Production.
1909 <sup>1</sup> .....	8,841,000	1915.....	11,216,000
1910.....	10,431,000	1916.....	11,874,000
1911.....	11,450,000	1917.....	13,281,000
1912.....	11,843,000	1918.....	13,362,000
1913.....	10,108,000	1919.....	13,902,000
1914.....	12,086,000		

<sup>1</sup> Census figures.

## PEARS—Continued.

TABLE 157.—Pears: Farm price, cents per bushel on 15th of month, 1910–1919.

Date.	1919	1918	1917	1916	1915	1914	1913	1912	1911	1910
Jan. 15.....			119.8	92.4	100.4	113.3	108.0			113.5
Feb. 15.....										106.4
Mar. 15.....									108.9	138.2
Apr. 15.....									134.0	130.5
May 15.....									138.6	139.6
June 15.....								113.2	126.0	
July 15.....								122.0	128.0	100.6
Aug. 15.....	188.4	168.4	132.2	109.0	80.8	98.8	109.9	106.3	118.0	
Sept. 15.....	183.0	157.8	125.0	102.7	83.8	92.8	119.3	100.0	103.8	100.9
Oct. 15.....	181.3	147.5	118.2	96.9	82.7	80.4	95.6	83.1	97.2	98.6
Nov. 15.....	182.0	140.1	116.1	93.3	89.8	77.5	93.0	79.3	85.1	100.8
Dec. 15.....	219.5	156.6		105.6	89.7	82.5	97.9	92.8	111.0	122.4

TABLE 158.—Estimated annual production of the commercial pear crop in the United States for 1918 and 1919.

[000 omitted.]

State.	1919 (prelim.).	1918 (prelim.).	State.	1919 (prelim.).	1918 (prelim.).
	<i>Bushels.</i>	<i>Bushels.</i>		<i>Bushels.</i>	<i>Bushels.</i>
New York.....	990	828	Colorado.....	392	182
New Jersey.....	200	211	Washington.....	1,620	1,300
Delaware.....	144	296	Oregon.....	615	406
Illinois.....	150	104	California.....	4,090	3,871
Michigan.....	123	307			
Missouri.....	38	24	United States.....	8,422	7,589
Texas.....	60	60			

## ORANGES.

TABLE 159.—Oranges: Production and value, 1915–1919.

Year.	United States.			Florida.			California.		
	Production (000 omitted).	Average price per box Dec. 1.	Farm value Dec. 1, (000 omitted).	Production (000 omitted).	Average price per box Dec. 1.	Farm value Dec. 1, (000 omitted).	Production (000 omitted).	Average price per box Dec. 1.	Farm value Dec. 1, (000 omitted).
	<i>Boxes.</i>		<i>Dollars.</i>	<i>Boxes.</i>		<i>Dollars.</i>	<i>Boxes.</i>		<i>Dollars.</i>
1915.....	21,200	\$2.39	50,692	6,150	\$1.88	11,562	15,050	\$2.60	39,130
1916.....	24,433	2.52	61,463	6,933	2.05	14,213	17,500	2.70	47,250
1917.....	10,593	2.60	27,556	3,500	2.30	8,050	7,093	2.75	19,506
1918.....	24,200	3.49	84,480	5,700	2.65	15,105	18,500	3.75	69,375
1919.....	23,916	2.68	64,169	6,400	2.50	16,000	17,516	2.75	48,169

CRANBERRIES.

TABLE 160.—Cranberries: Acreage, production, and farm value, by States, 1919, and totals, 1914-1919.

[Leading producing States.]

State and year.	Acreage.	Average yield per acre.	Production.	Average farm price per barrel Dec. 1.	Farm value Dec. 1.
	<i>Acres.</i>	<i>Barrels.</i>	<i>Barrels.</i>	<i>Dollars.</i>	<i>Dollars.</i>
Massachusetts.....	14,000	24.0	336,000	8.50	2,850,000
New Jersey.....	10,200	15.8	161,000	8.00	1,288,000
Wisconsin.....	1,900	23.4	44,000	8.55	376,000
Total of above.....	26,100	20.7	541,000	8.36	4,520,000
1918.....	25,400	13.9	352,000	10.77	3,791,000
1917.....	18,200	13.7	249,000	10.24	2,550,000
1916.....	26,200	18.0	471,000	7.32	3,449,000
1915.....	23,100	19.1	441,000	6.59	2,908,000
1914.....	22,000	31.7	697,000	3.97	2,766,000

HOPS.

TABLE 161.—Hops: Area and production in undermentioned countries, 1909-1918.

[000 omitted.]

Country.	Area.				Production.			
	Average 1909-1913. <sup>1</sup>	1916	1917	1918	Average 1909-1913. <sup>1</sup>	1916	1917	1918
NORTH AMERICA.								
United States.....	<i>Acres.</i> ( <sup>2</sup> )	<i>Acres.</i> 41	<i>Acres.</i> 30	<i>Acres.</i> 28	<i>Pounds.</i> 53,655	<i>Pounds.</i> 50,595	<i>Pounds.</i> 29,388	<i>Pounds.</i> 20,193
Canada.....	1	( <sup>2</sup> )	( <sup>2</sup> )	( <sup>2</sup> )	1,208	( <sup>2</sup> )	( <sup>2</sup> )	( <sup>2</sup> )
Total.....					54,863			
EUROPE.								
Austria <sup>3</sup> .....	50	( <sup>2</sup> )	( <sup>2</sup> )	( <sup>2</sup> )	27,523	( <sup>2</sup> )	( <sup>2</sup> )	( <sup>2</sup> )
Hungary <sup>3</sup> .....	5	( <sup>2</sup> )	( <sup>2</sup> )	( <sup>2</sup> )	2,932	( <sup>2</sup> )	( <sup>2</sup> )	( <sup>2</sup> )
Croatia-Slavonia <sup>3</sup> .....	1	( <sup>2</sup> )	( <sup>2</sup> )	( <sup>2</sup> )	263	( <sup>2</sup> )	( <sup>2</sup> )	( <sup>2</sup> )
Belgium.....	6	( <sup>2</sup> )	( <sup>2</sup> )	( <sup>2</sup> )	7,096	( <sup>2</sup> )	( <sup>2</sup> )	( <sup>2</sup> )
France <sup>2</sup> .....	7	4	4	3	6,948	4,958	3,937	( <sup>2</sup> )
Germany <sup>2</sup> .....	67	( <sup>2</sup> )	( <sup>2</sup> )	27	30,105	( <sup>2</sup> )	( <sup>2</sup> )	1,833
Russia <sup>3</sup> .....	( <sup>2</sup> )	( <sup>2</sup> )	( <sup>2</sup> )	( <sup>2</sup> )	11,765	( <sup>2</sup> )	( <sup>2</sup> )	( <sup>2</sup> )
United Kingdom, England.....	36	31	17	16	33,058	34,480	24,721	14,560
Total.....	172				119,600			
Australia.....	1	2	1	( <sup>2</sup> )	1,564	2,110	1,752	( <sup>2</sup> )
Grand total.....	174				176,117			

<sup>1</sup> Five-year average, except where statistics were not available.

<sup>2</sup> No official estimates.

<sup>3</sup> Old boundaries.

TABLE 162.—Hops: Total production of countries named in Table 161, 1895-1915.

Year.	Production.	Year.	Production.	Year.	Production.
	<i>Pounds.</i>		<i>Pounds.</i>		<i>Pounds.</i>
1895.....	204,894,000	1902.....	170,063,000	1909.....	128,173,000
1896.....	168,509,000	1903.....	174,457,000	1910.....	188,951,000
1897.....	189,219,000	1904.....	178,802,000	1911.....	163,810,000
1898.....	166,100,000	1905.....	277,260,000	1912.....	224,493,000
1899.....	231,563,000	1906.....	180,998,000	1913.....	174,642,000
1900.....	174,683,000	1907.....	215,923,000	1914.....	224,179,000
1901.....	201,902,000	1908.....	230,220,000	1915.....	163,084,000

## HOPS—Continued.

TABLE 163.—Hops: Acreage, production, and value by States in 1919, and totals, 1915–1919.

[Leading producing States.]

State and year.	Acreage.	Average yield per acre.	Production.	Average farm price per pound Nov. 15.	Farm value Nov. 15.
	<i>Acres.</i>	<i>Pounds.</i>	<i>Pounds.</i>	<i>Cents.</i>	<i>Dollars.</i>
New York.....	2,300	690	1,587,000	73.0	1,159,000
Washington.....	2,600	1,340	3,484,000	75.0	2,613,000
Oregon.....	8,000	800	6,400,000	80.0	5,120,000
California.....	11,000	1,625	17,875,000	77.0	13,764,000
Total.....	23,900	1,227.9	29,346,000	77.2	22,656,000
1918.....	25,900	829.4	21,481,000	19.3	4,150,000
1917.....	29,900	982.9	29,388,000	33.3	9,795,000
1916.....	43,900	1,152.5	50,595,000	12.0	6,073,000
1915.....	44,653	1,186.6	52,986,000	11.7	6,203,000

TABLE 164.—Hops: Farm price, cents per pound on 15th of month, 1910–1919.

Date.	1919	1918	1917	1916	1915	1914	1913	1912	1911	1910
Jan. 15.....	31.0		11.8	13.0	14.8	26.6	19.7	44.8	19.3	23.4
Feb. 15.....	32.5			12.0	11.1	19.1	16.9	38.8	17.8	22.6
Mar. 15.....	32.2			13.5	12.0	20.5		40.1	19.2	18.4
Apr. 15.....				14.3	12.4	20.6	15.0		18.2	20.4
May 15.....				12.7	10.9	21.8	13.4	37.2	20.9	16.6
June 15.....				10.5	9.6		14.1		22.6	
July 15.....				10.1	10.5	14.7	14.8	28.9	25.8	
Aug. 15.....			25.9		15.0	20.0		18.8	36.5	
Sept. 15.....	56.6		36.5	16.4	15.8	24.4	20.9	19.8	40.6	
Oct. 15.....		12.7	42.7	21.0	14.8	19.1	29.5	22.2	37.8	13.3
Nov. 15.....	77.0	19.7	33.7	21.5	13.8	15.6	26.0	19.7	41.4	14.2
Dec. 15.....	77.2	19.3	33.3	18.2	12.3	13.2	29.4	17.8	42.5	14.6

TABLE 165.—Hop consumption and movement, 1910–1919.

[The total hop movement of the United States for the last 11 years is shown. The figures on the quantity consumed by brewers have been compiled from the records of the Treasury Department; exports and imports are as reported by the Department of Commerce.]

Year ending June 30—	Consumed by brewers.	Exports.		Total of brewers' consumption and exports.	Imports.	Net domestic movement.
		Domestic.	Foreign.			
	<i>Pounds.</i>	<i>Pounds.</i>	<i>Pounds.</i>	<i>Pounds.</i>	<i>Pounds.</i>	<i>Pounds.</i>
1919.....	13,924,650	7,466,952	4,719	21,396,321	6	21,396,315
1918.....	33,481,415	3,494,579	37,823	37,013,817	121,288	36,892,529
1917.....	41,949,225	4,874,876	26,215	46,850,316	236,849	46,613,467
1916.....	37,451,610	22,409,818	134,571	59,995,999	675,704	59,320,295
1915.....	38,839,294	16,210,443	16,947	55,066,684	11,651,332	43,415,352
1914.....	43,987,623	24,262,896	30,224	68,280,743	5,382,025	62,898,718
1913.....	44,237,735	17,591,195	35,859	61,864,789	8,494,144	53,370,645
1912.....	42,436,665	12,190,663	35,869	54,663,197	2,991,125	51,672,072
1911.....	45,068,811	13,104,774	17,974	58,191,559	8,557,531	49,634,028
1910.....	43,293,764	10,589,254	14,590	53,897,608	3,200,560	50,697,048

TABLE 166.—Hops: Wholesale price per pound, 1913-1919.

Date.	New York.			Cincinnati.			Chicago.			San Francisco.								
	Choice state.			Prime.			Pacific Coast, good to choice.			Sacramento Valley, choice.			Willamette Valley, choice. <sup>1</sup>			Eastern Washington, choice. <sup>2</sup>		
	Low.	High.	Average.	Low.	High.	Average.	Low.	High.	Average.	Low.	High.	Average.	Low.	High.	Average.	Low.	High.	Average.
1913.	<i>Cents.</i>	<i>Cents.</i>	<i>Cents.</i>	<i>Cents.</i>	<i>Cents.</i>	<i>Cents.</i>	<i>Cents.</i>	<i>Cents.</i>	<i>Cents.</i>	<i>Cents.</i>	<i>Cents.</i>	<i>Cents.</i>	<i>Cents.</i>	<i>Cents.</i>	<i>Cents.</i>	<i>Cents.</i>	<i>Cents.</i>	<i>Cents.</i>
January-June.....	17	32	.....	18	23	.....	15	24	.....	18	20	.....	19	21	.....	19	21	.....
July-December.....	17	48	.....	18	32	.....	17	31	.....	18	28	.....	18	30	.....	19	30	.....
1914.																		
January-June.....	36	48	.....	21	27½	.....	18	27	.....	16	28	.....	16	30	.....	16	30	.....
July-December.....	23	50	.....	13½	22	.....	13	22	.....	10	19	.....	11	20	.....	10	20	.....
1915.																		
January-June.....	13	25	.....	16	17	.....	10	18	.....	9	15	.....	10	16	.....	10	15	.....
July-December.....	13	30	.....	15½	16	.....	10	16	.....	7½	14	.....	10	16	.....	10	15	.....
1916.																		
January-June.....	18	27	.....	14	15½	.....	14	17	.....	7½	11	.....	09	12½	.....	9	12½	.....
July-December.....	15	55	.....	13	16½	.....	10	18	.....	8	14	.....	07	14	.....	7	14	.....
1917.																		
January-June.....	34	50	.....	11	15	.....	10	15	.....	5	10½	.....	07	11	.....	6	11½	.....
July-December.....	34	90	.....	13	43	.....	10	46	.....	5	37½	.....	07	40	.....	6	40	.....
1918.																		
January-June.....	40	54	42.6	.....	.....	.....	18	24	.....	15	20	16.1	15	20	19.0	19	22½	19.8
July-December.....	23	42	33.2	.....	.....	.....	13	40	.....	15	15	15.0	19	19	19.0	19	19	19.0
1919.																		
January.....	37	40	37.8	.....	.....	46	(3)	(3)	(3)	30	42	38.0	35	40	40.1	35	45	43.2
February.....	40	40	40.0	.....	.....	46	(3)	(3)	(3)	34	42	36.1	36	45	36.3	34	45	37.0
March.....	40	40	40.0	.....	.....	46	(3)	(3)	(3)	30	37	33.2	36	42	39.3	36	40	38.0
April.....	40	42	40.2	.....	.....	46	(3)	(3)	(3)	(4)	(4)	(4)	41	42	41.5	.....	.....	.....
May.....	39	46	42.2	.....	.....	46	(3)	(3)	(3)	(4)	(4)	(4)	41	42	41.5	.....	.....	.....
June.....	46	63	56.9	.....	.....	46	(3)	(3)	(3)	(4)	(4)	(4)	41	50	46.8	.....	.....	.....
January-June.....	37	63	42.8	.....	.....	46	.....	.....	.....	30	42	35.8	35	50	40.9	34	45	39.4

<sup>1</sup> 1912 quotations are for all grades. Called "Oregon" hops in 1916; Sonoma hops for 1919.  
<sup>2</sup> Called "Washington" hops in 1916; Oregon hops for January-March, 1919.

<sup>3</sup> No quotations.  
<sup>4</sup> Nominal.

TABLE 166.—Hops: Wholesale price per pound, 1913-1919—Continued.

Date.	New York.			Cincinnati.			Chicago.			San Francisco.								
	Choice state.			Prime.			Pacific Coast, good to choice.			Sacramento Valley, choice.			Willamette Valley, choice.			Eastern Washington, choice.		
	Low.	High.	Average.	Low.	High.	Average.	Low.	High.	Average.	Low.	High.	Average.	Low.	High.	Average.	Low.	High.	Average.
<i>Cents.</i>																		
July.....	63	65	64.9	.....	.....	60	(1)	(1)	(1)	(2)	(2)	(2)	48	52	49.0	(2)	(2)	(2)
August.....	65	65	65.0	.....	.....	66	(1)	(1)	(1)	(2)	(2)	(2)	52	52	52.0	(2)	(2)	(2)
September.....	80	82	81.3	70	75	.....	(1)	(1)	(1)	52	59	53.9	55	60	56.1	54	55	54.6
October.....	82	85	82.8	.....	.....	.....	(1)	(1)	(1)	59	83	71.8	60	85	77.5	67	84	73.0
November.....	85	85	85.0	.....	.....	.....	(1)	(1)	(1)	75	90	82.7	85	85	85.0	84	85	84.5
December.....	80	85	82.5	96	97	.....	(1)	(1)	(1)	85	90	87.5	85	85	85.0	84	84	84.0
July-December.....	63	85	76.9	.....	.....	.....	(1)	(1)	(1)	52	90	74.0	48	85	67.4	84	84	74.0

1 No quotations.  
2 Nominal.

HOPS—Continued.

TABLE 167.—Hops: International trade, calendar years, 1919–1913.

[Lupulin and hopfenmehl (hop meal) are not included with hops in the data shown. See "General note."]

[000 omitted.]

EXPORTS.

Country.	Average 1909– 1913.	1917 (prelim.).	1918 (prelim.).	Country.	Average 1909– 1913.	1917 (prelim.).	1918 (prelim.).
<i>From—</i>	<i>Pounds.</i>	<i>Pounds.</i>	<i>Pounds.</i>	<i>From—</i>	<i>Pounds.</i>	<i>Pounds.</i>	<i>Pounds.</i>
Austria-Hungary...	18,333	.....	.....	New Zealand.....	352	314	225
Belgium.....	4,814	.....	.....	Russia.....	2,348	.....	.....
France.....	335	491	612	United Kingdom...	2,162	1,453	775
Germany.....	17,564	.....	.....	United States.....	15,416	4,138	3,670
Netherlands.....	1,405	.....	.....	Other countries....	212	.....	.....
				Total.....	62,941	.....	.....

IMPORTS.

<i>Into—</i>				<i>Into—</i>			
Australia.....	1,106	110	.....	Germany.....	7,688	.....	.....
Austria-Hungary...	938	.....	.....	Netherlands.....	2,938	.....	.....
Belgium.....	6,915	.....	.....	Russia.....	1,258	.....	.....
British India.....	246	335	532	Sweden.....	987	1,230	.....
British South Africa	498	442	570	Switzerland.....	1,257	469	300
Canada.....	1,396	790	849	United Kingdom...	21,028	955	.....
Denmark.....	1,027	1,450	.....	United States.....	6,235	194	77
France.....	5,436	1,238	888	Other countries....	4,123	.....	.....
				Total.....	63,076	.....	.....

BEANS.

TABLE 168.—Beans: Area and production in undermentioned countries, 1909–1918.

[000 omitted.]

Country.	Area.				Production.			
	Average 1909– 1913. <sup>1</sup>	1916	1917	1918	Average 1909– 1913. <sup>1</sup>	1916	1917	1918
<b>NORTH AMERICA.</b>								
United States (6 States).....	Acres. 788	Acres. 1,107	Acres. 1,769	Acres. 1,106	Bu. 11,166	Bu. 10,715	Bu. 15,283	Bu. 17,397
Canada:								
Nova Scotia.....	1	1	1	9	32	14	18	143
New Brunswick.....	2	( <sup>2</sup> )	( <sup>3</sup> )	5	21	4	6	86
Quebec.....	6	4	55	110	125	78	827	1,867
Ontario.....	42	27	36	100	796	317	423	1,388
Other.....	( <sup>3</sup> )	( <sup>3</sup> )	( <sup>3</sup> )	5	( <sup>3</sup> )	( <sup>3</sup> )	( <sup>3</sup> )	80
Total Canada.....	51	32	92	229	974	413	1,274	3,564
Mexico.....								4,858
<b>SOUTH AMERICA.</b>								
Argentina.....	65	( <sup>3</sup> )	( <sup>3</sup> )	( <sup>3</sup> )	( <sup>3</sup> )	( <sup>3</sup> )	( <sup>3</sup> )	( <sup>3</sup> )
Brazil.....	( <sup>3</sup> )	( <sup>3</sup> )	( <sup>3</sup> )	( <sup>3</sup> )	( <sup>3</sup> )	( <sup>3</sup> )	13,139	( <sup>3</sup> )
Chile.....	79	( <sup>3</sup> )	( <sup>3</sup> )	( <sup>3</sup> )	1,398	1,914	( <sup>3</sup> )	( <sup>3</sup> )
<b>EUROPE.</b>								
Austria <sup>5</sup> .....	648	( <sup>3</sup> )	( <sup>3</sup> )	( <sup>3</sup> )	9,666	( <sup>3</sup> )	( <sup>3</sup> )	( <sup>3</sup> )
Hungary <sup>5,6</sup> .....	44	( <sup>3</sup> )	( <sup>3</sup> )	( <sup>3</sup> )	599	( <sup>3</sup> )	( <sup>3</sup> )	( <sup>3</sup> )
Do. <sup>5,7</sup> .....	1,471	( <sup>3</sup> )	( <sup>3</sup> )	( <sup>3</sup> )	6,917	( <sup>3</sup> )	( <sup>3</sup> )	( <sup>3</sup> )
Croatia-Slavonia <sup>5,6</sup> .....	25	( <sup>3</sup> )	( <sup>3</sup> )	( <sup>3</sup> )	265	( <sup>3</sup> )	( <sup>3</sup> )	( <sup>3</sup> )
Do. <sup>5,7</sup> .....	472	( <sup>3</sup> )	( <sup>3</sup> )	( <sup>3</sup> )	2,011	( <sup>3</sup> )	( <sup>3</sup> )	( <sup>3</sup> )
Belgium.....	21	( <sup>3</sup> )	( <sup>3</sup> )	( <sup>3</sup> )	604	( <sup>3</sup> )	( <sup>3</sup> )	( <sup>3</sup> )
Bulgaria <sup>5</sup> .....	178	( <sup>3</sup> )	( <sup>3</sup> )	( <sup>3</sup> )	1,895	( <sup>3</sup> )	( <sup>3</sup> )	( <sup>3</sup> )
Denmark.....	9	11	( <sup>3</sup> )	( <sup>3</sup> )	369	269	( <sup>3</sup> )	( <sup>3</sup> )
France <sup>6</sup> .....	554	489	484	( <sup>3</sup> )	9,518	6,053	5,955	( <sup>3</sup> )
Italy.....	2,023	2,555	1,099	1,077	21,038	17,372	13,153	15,609
Luxemburg.....	4	( <sup>3</sup> )	( <sup>3</sup> )	( <sup>3</sup> )	73	( <sup>3</sup> )	( <sup>3</sup> )	( <sup>3</sup> )

<sup>1</sup> Five-year average except where statistics were not available.

<sup>2</sup> Less than 500 acres.

<sup>3</sup> No official statistics.

<sup>4</sup> Unofficial.

<sup>5</sup> Old boundaries.

<sup>6</sup> Grown alone.

<sup>7</sup> Grown with corn.

## BEANS—Continued.

TABLE 168.—Beans: Area and production in undermentioned countries, 1909-1918—Con.  
[000 omitted.]

Country.	Area.				Production.			
	Average 1909- 1913.	1916	1917	1918	Average 1909- 1913.	1916	1917	1918
EUROPE—continued.								
	<i>Acres.</i>	<i>Acres.</i>	<i>Acres.</i>	<i>Acres.</i>	<i>Bu.</i>	<i>Bu.</i>	<i>Bu.</i>	<i>Bu.</i>
Netherlands.....	64	59	92	(1)	1,853	1,742	2,526	(1)
Roumania <sup>2,3</sup> .....	93	188	(1)	(1)	1,385	(1)	(1)	(1)
Do. <sup>2,4</sup> .....	1,265	(1)	(1)	(1)	3,630	(1)	(1)	(1)
Russia proper <sup>2</sup> .....	523	744	(1)	(1)	6,027	7,758	(1)	(1)
Poland <sup>2</sup> .....	29	(1)	(1)	(1)	505	(1)	(1)	(1)
Northern Caucasia <sup>2</sup> .....	4	(1)	(1)	(1)	58	(1)	(1)	(1)
Serbia <sup>2</sup> .....	25	(1)	(1)	(1)	1,676	(1)	(1)	(1)
Spain.....	1,132	1,225	<sup>5</sup> 519	<sup>5</sup> 489	11,908	14,755	<sup>5</sup> 7,892	<sup>5</sup> 7,489
Sweden.....	10	6	5	6	174	195	91	132
United Kingdom:								
England.....	276	228	202	239	8,015	6,871	3,462	7,032
Wales.....	1	1	1	3	33	28	29	78
Scotland.....	9	5	6	7	318	196	237	266
Ireland.....	2	1	1	<sup>6</sup> 2	67	46	65	(1)
Total United Kingdom.....	288	235	210	251	8,433	7,141	3,793	.....
ASIA.								
British India <sup>7</sup> .....	13,156	13,224	15,307	16,106	143,360	<sup>8</sup> 127,979	<sup>8</sup> 147,467	<sup>8</sup> 164,267
Japanese Empire:								
Japan.....	1,598	1,584	(1)	(1)	23,175	26,484	(1)	(1)
Formosa <sup>7</sup> .....	79	88	83	(1)	657	780	661	(1)
Korea.....	(1)	(1)	(1)	(1)	(1)	(1)	(1)	(1)
Total Japanese Empire.....	1,677	.....	.....	.....	23,832	.....	.....	.....
Russia (9 governments) <sup>2</sup> .....	22	(1)	(1)	(1)	225	(1)	(1)	(1)
AFRICA.								
Algeria.....	110	(1)	(1)	(1)	1,132	(1)	(1)	(1)
Egypt.....	544	583	472	(1)	(1)	(1)	(1)	(1)
AUSTRALASIA.								
Australia.....	40	.....	.....	.....	794	.....	.....	.....

<sup>1</sup> No official statistics.<sup>2</sup> Old boundaries.<sup>3</sup> Grown alone.<sup>4</sup> Grown with corn.<sup>5</sup> Unofficial.<sup>6</sup> Includes peas.<sup>7</sup> Includes other pulse.<sup>8</sup> Incomplete.

TABLE 169.—Beans (dry): Acreage, production, and value by States 1919, and totals, 1914-1919.

[Leading producing States.]

State and year.	Acreage.	Average yield per acre.	Production.	Average farm price per bushel Nov. 15.	Farm value Nov. 15.
	<i>Acres.</i>	<i>Bushels.</i>	<i>Bushels.</i>	<i>Dollars.</i>	<i>Dollars.</i>
New York.....	100,000	14.5	1,450,000	4.90	7,105,000
Michigan.....	310,000	13.0	4,030,000	4.20	16,926,000
Colorado.....	69,000	6.5	448,000	3.50	1,568,000
New Mexico.....	128,000	7.5	960,000	3.70	3,552,000
Arizona.....	16,000	8.5	136,000	4.50	612,000
California.....	395,000	11.3	4,464,000	4.35	19,418,000
Total.....	1,018,000	11.3	11,488,000	4.28	49,181,000
1918.....	1,744,000	10.0	17,397,000	5.28	91,863,000
1917.....	1,821,000	8.8	16,045,000	6.50	104,350,000
1916.....	1,107,000	9.7	10,715,000	5.10	54,686,000
1915.....	928,000	11.1	10,321,000	2.59	26,771,000
1914.....	875,000	13.2	11,585,000	2.26	26,213,000



BEANS—Continued.

TABLE 170.—Beans: Farm price per bushel on 15th of each month, 1910-1919.

Date.	1919	1918	1917	1916	1915	1914	1913	1912	1911	1910
Jan. 15.....	\$4.98	\$7.00	\$5.71	\$3.47	\$2.63	\$2.17	\$2.26	\$2.38	\$2.20	\$2.23
Feb. 15.....	4.52	7.08	6.07	3.43	3.02	2.09	2.19	2.38	2.23	2.23
Mar. 15.....	4.40	6.95	6.49	3.34	2.89	2.05	2.10	2.42	2.17	2.17
Apr. 15.....	4.44	6.95	7.37	3.42	2.81	2.11	2.11	2.37	2.20	2.16
May 15.....	4.19	6.67	8.94	3.56	2.93	2.31	2.18	2.52	2.17	2.17
June 15.....	4.39	6.28	8.99	3.72	2.87	2.23	2.23	2.62	2.19	2.29
July 15.....	4.25	5.88	8.07	5.09	2.75	2.22	2.22	2.47	2.23	2.34
Aug. 15.....	4.30	6.11	7.29	4.59	2.67	2.54	2.11	2.40	2.20	2.27
Sept. 15.....	4.36	5.67	6.69	4.60	2.70	2.46	2.08	2.38	2.26	2.28
Oct. 15.....	4.27	5.52	7.48	4.47	2.93	2.17	2.25	2.34	2.27	2.25
Nov. 15.....	4.42	5.46	7.33	5.53	3.03	2.28	2.20	2.25	2.34	2.14
Dec. 15.....	4.41	4.86	7.00	5.77	3.30	2.40	2.12	2.31	2.42	2.20

TABLE 171.—Beans: Wholesale price per bushel, 1913-1919.

Date.	Boston.			Chicago.			Detroit.			San Francisco.		
	Pea.			Pea. <sup>1</sup>			Pea (100 lbs.).			Small white (100 lbs.).		
	Low.	High.	Average.	Low.	High.	Average.	Low.	High.	Average.	Low.	High.	Average.
1913.												
January-June.....	Dolls. 2.25	Dolls. 2.60	Dolls. 2.45	Dolls. 1.25	Dolls. 2.50	Dolls. 1.86	Dolls. 1.80	Dolls. 2.20	Dolls. -----	Dolls. 4.50	Dolls. 5.90	Dolls. 4.91
July-December.....	2.15	2.40	2.28	1.15	2.25	1.76	1.75	2.05	-----	4.50	6.00	5.41
1914.												
January-June.....	2.10	2.35	2.20	1.60	2.30	1.99	1.80	2.10	-----	4.75	5.50	5.15
July-December.....	2.15	3.10	2.59	1.95	3.10	2.44	1.85	2.90	-----	4.00	6.00	4.81
1915.												
January-June.....	2.95	3.50	3.24	2.40	3.50	3.08	2.15	3.20	2.68	4.50	5.70	5.40
July-December.....	2.85	4.10	3.47	2.62	4.10	3.30	2.60	3.60	3.15	4.50	6.40	5.19
1916.												
January-June.....	3.80	5.85	4.08	3.00	8.00	3.94	3.50	6.00	3.86	6.25	11.50	6.70
July-December.....	4.50	7.25	5.83	5.00	8.00	6.34	4.90	7.00	5.77	7.50	11.00	9.40
1917.												
January-June.....	6.50	10.25	8.23	6.40	11.25	8.47	6.25	10.00	7.97	10.50	16.00	13.21
July-December.....	8.00	15.00	10.26	7.25	14.50	9.71	7.25	13.25	9.24	11.75	15.75	13.20
1918.												
January-June.....	12.00	14.50	13.37	10.00	15.00	12.61	9.50	13.25	11.64	11.75	12.75	12.35
July-December.....	9.00	12.00	10.78	8.25	12.50	10.37	8.63	10.25	9.27	8.90	12.25	10.94
1919.												
January.....	9.00	10.00	9.55	7.50	9.25	8.82	7.75	9.00	8.65	7.00	8.90	8.56
February.....	7.00	9.00	8.15	7.00	7.75	7.29	6.50	8.00	7.37	6.90	7.50	7.29
March.....	6.50	8.00	7.13	6.50	7.35	6.98	6.75	7.75	7.24	5.75	6.90	6.59
April.....	6.50	8.00	7.45	6.75	7.75	7.27	7.25	7.75	7.32	6.50	6.75	6.73
May.....	7.00	8.00	7.63	7.50	8.25	7.84	7.40	8.00	7.79	6.70	6.75	6.78
June.....	6.50	8.00	7.60	7.75	8.25	8.03	7.10	7.75	7.46	6.70	7.15	6.90
January-June.....	6.50	10.00	7.92	6.80	9.25	7.70	6.50	9.00	7.64	5.75	8.90	7.14
July.....	6.00	8.00	6.94	7.25	8.25	7.63	7.15	8.25	7.49	6.75	7.25	7.00
August.....	7.00	9.00	7.80	8.50	9.50	9.02	8.10	8.75	8.30	7.25	8.00	7.90
September.....	7.50	8.75	8.21	8.50	9.00	8.75	7.00	8.10	7.59	7.50	7.50	7.50
October.....	7.25	8.25	7.68	7.25	8.75	8.10	6.75	7.50	7.15	6.25	7.50	6.73
November.....	7.00	7.75	7.37	7.25	8.00	7.66	6.75	7.00	6.86	6.25	6.50	6.32
December.....	7.00	8.00	7.40	7.25	8.00	7.64	7.00	7.35	7.20	6.20	6.50	6.30
July-December.....	6.00	9.00	7.57	7.25	9.50	8.13	6.75	8.75	7.43	6.20	8.00	6.96

<sup>1</sup> Hand picked, choice to fancy.

## SOY BEANS.

TABLE 172.—Soy beans: Acreage, production, and value, by States 1919, and totals 1917-1919.

[Leading producing States.]

State and year.	Acreage, <sup>1</sup>	Average yield per acre.	Production.	Average farm price per bushel Nov. 15.	Farm value Nov. 15.
	<i>Acres.</i>	<i>Bushels.</i>	<i>Bushels.</i>	<i>Dollars.</i>	<i>Dollars.</i>
Pennsylvania.....	2,000	18.0	36,000	4.10	148,000
Virginia.....	30,000	18.5	550,000	4.10	2,255,000
North Carolina.....	82,000	14.0	1,148,000	3.10	3,559,000
South Carolina.....	1,000	6.0	6,000	2.80	17,000
Georgia.....	2,000	10.0	25,000	2.90	72,000
Ohio.....	2,000	7.0	14,000	4.80	67,000
Indiana.....	2,000	14.0	35,000	4.50	158,000
Illinois.....	6,000	12.5	78,000	4.20	328,000
Wisconsin.....	1,000	7.5	10,000	4.20	42,000
Missouri.....	6,000	14.0	77,000	3.50	270,000
Kentucky.....	7,000	12.0	84,000	4.00	336,000
Tennessee.....	2,000	5.0	10,000	3.00	30,000
Alabama.....	7,000	9.5	66,000	2.90	191,000
Mississippi.....	8,000	15.0	120,000	2.80	336,000
Other.....	10,000	.....	143,000	.....	495,000
Total.....	168,000	14.3	2,402,000	3.46	8,304,000
1918.....	169,000	17.7	2,997,000	3.20	9,590,000
1917.....	154,000	14.8	2,283,000	2.86	6,529,000

<sup>1</sup> Acres rounded to nearest thousands.

TABLE 173.—Soy beans: Farm price per bushel on 15th of month, 1913-1919.

Date.	1919	1918	1917	1916	1915	1914	1913
Jan. 15.....	\$3.00	\$3.47	\$2.20	\$2.31	\$2.35	\$1.96	.....
Feb. 15.....	3.00	3.82	2.45	2.39	2.26	1.80	.....
Oct. 15.....	3.34	3.36	2.73	2.13	1.88	2.08	\$1.96
Nov. 15.....	3.35	3.20	2.86	2.13	2.08	2.15	1.57
Dec. 15.....	3.44	3.29	3.33	2.18	2.23	2.24	1.72

## COWPEAS.

TABLE 174.—Cowpeas: Acreage, production, and value by States 1919, and totals, 1917-1919.

[Leading producing States.]

State and year.	Acreage.	Average yield per acre.	Production.	Average farm price per bushel Dec. 1.	Farm value Dec. 1.
	<i>Acres.</i>	<i>Bushels.</i>	<i>Bushels.</i>	<i>Cents.</i>	<i>Dollars.</i>
Virginia.....	76,000	12.5	950,000	320	3,040,000
North Carolina.....	243,000	9.4	2,284,000	270	6,167,000
South Carolina.....	100,000	7.0	700,000	290	2,030,000
Georgia.....	220,000	4.5	990,000	240	2,376,000
Florida.....	24,000	9.0	216,000	300	648,000
Indiana.....	4,000	15.0	60,000	340	204,000
Illinois.....	13,000	8.0	104,000	340	354,000
Missouri.....	19,000	11.0	209,000	340	711,000
Kentucky.....	20,000	10.0	200,000	320	640,000
Tennessee.....	5,000	3.0	15,000	260	39,000
Alabama.....	408,000	5.6	2,285,000	230	5,256,000
Mississippi.....	40,000	4.0	160,000	250	400,000
Louisiana.....	130,000	6.0	780,000	320	2,496,000
Texas.....	90,000	11.0	990,000	280	2,772,000
Oklahoma.....	6,000	8.0	48,000	290	139,000
Arkansas.....	75,000	5.0	375,000	290	1,088,000
Other.....	5,000	12.0	60,000	.....	164,000
Total.....	1,478,000	7.1	10,426,000	273.6	28,524,000
1918.....	2,003,000	6.2	12,427,000	231.4	28,756,000
1917.....	1,829,000	7.0	12,787,000	227.1	29,039,000

COWPEAS—Continued.

TABLE 175.—Cowpeas: Farm price, cents per bushel on 15th of month, 1915–1919.

Date.	1919	1918	1917	1916	1915	Date.	1919	1918	1917	1916	1915
Jan. 15.....	238.9	262.2	192.2	156.3	.....	July 15.....	342.8	248.4	303.2	135.1	179.8
Feb. 15.....	252.1	292.5	210.0	157.2	187.0	Aug. 15.....	310.3	241.3	265.4	141.3	174.4
Mar. 15.....	248.8	301.5	231.8	153.7	198.8	Sept. 15.....	269.4	226.2	217.0	142.4	155.4
Apr. 15.....	267.6	292.8	253.4	150.2	203.7	Oct. 15.....	260.9	233.9	219.5	148.1	156.0
May 15.....	292.3	283.3	293.1	148.8	201.9	Nov. 15.....	270.7	231.4	227.1	161.6	151.4
June 15.....	343.9	257.4	309.1	140.0	194.5	Dec. 15.....	280.6	237.6	237.5	177.0	151.8

PEAS.

TABLE 176.—Peas: Area and production in undermentioned countries, 1909–1918.

[000 omitted.]

Country.	Area.				Production.			
	Average 1909–1913 <sup>1</sup>	1916	1917	1918	Average 1909–1913 <sup>1</sup>	1916	1917	1918
NORTH AMERICA.								
United States.....	<i>Acres.</i> <sup>2</sup> 1,305	<i>Acres.</i> ( <sup>3</sup> )	<i>Acres.</i> ( <sup>3</sup> )	<i>Acres.</i> ( <sup>3</sup> )	<i>Bu.</i> <sup>2</sup> 7,129	<i>Bu.</i> ( <sup>3</sup> )	<i>Bu.</i> ( <sup>3</sup> )	<i>Bu.</i> ( <sup>3</sup> )
Canada:								
Prince Edward Islands.....	1	( <sup>4</sup> )	( <sup>4</sup> )	( <sup>4</sup> )	4	1	1	9
Nova Scotia.....	1	( <sup>4</sup> )	( <sup>4</sup> )	2	14	3	2	45
New Brunswick.....	1	( <sup>4</sup> )	( <sup>4</sup> )	4	21	7	6	82
Quebec.....	33	22	66	100	520	302	798	1,174
Ontario.....	257	123	123	99	4,482	1,796	2,110	1,458
Saskatchewan.....	( <sup>4</sup> )	2	3	4	7	52	45	83
Alberta.....	( <sup>4</sup> )	1	2	2	7	13	32	22
British Columbia.....	1	1	1	2	42	44	32	62
Total, Canada.....	304	152	498	213	5,097	2,218	3,026	2,935
SOUTH AMERICA.								
Chile <sup>6</sup> .....	26	36	( <sup>3</sup> )	( <sup>3</sup> )	387	515	( <sup>3</sup> )	( <sup>3</sup> )
EUROPE.								
Austria <sup>6</sup> .....	( <sup>8</sup> )	( <sup>3</sup> )	( <sup>3</sup> )	( <sup>3</sup> )	( <sup>8</sup> )	( <sup>3</sup> )	( <sup>3</sup> )	( <sup>3</sup> )
Hungary <sup>6 7</sup> .....	32	( <sup>3</sup> )	( <sup>3</sup> )	( <sup>3</sup> )	427	( <sup>3</sup> )	( <sup>3</sup> )	( <sup>3</sup> )
Croatia-Slavonia <sup>6 7</sup> .....	12	( <sup>3</sup> )	( <sup>3</sup> )	( <sup>3</sup> )	159	( <sup>3</sup> )	( <sup>3</sup> )	( <sup>3</sup> )
Belgium <sup>6</sup> .....	12	( <sup>3</sup> )	( <sup>3</sup> )	( <sup>3</sup> )	390	( <sup>3</sup> )	( <sup>3</sup> )	( <sup>3</sup> )
France <sup>6</sup> .....	<sup>6</sup> 73	33	28	( <sup>3</sup> )	<sup>5</sup> 1,308	598	386	( <sup>3</sup> )
Italy <sup>6</sup> .....	( <sup>3</sup> )	( <sup>3</sup> )	( <sup>3</sup> )	( <sup>3</sup> )	3,829	2,704	2,656	( <sup>3</sup> )
Luxemburg <sup>7</sup> .....	2	( <sup>3</sup> )	( <sup>3</sup> )	( <sup>3</sup> )	34	( <sup>3</sup> )	( <sup>3</sup> )	( <sup>3</sup> )
Netherlands.....	65	61	89	90	1,581	1,600	2,529	( <sup>3</sup> )
Roumania <sup>6 7</sup> .....	42	77	( <sup>3</sup> )	( <sup>3</sup> )	675	( <sup>3</sup> )	( <sup>3</sup> )	( <sup>3</sup> )
Russia proper <sup>6</sup> .....	2,628	<sup>9</sup> 1,070	( <sup>3</sup> )	( <sup>3</sup> )	27,973	<sup>9</sup> 12,201	( <sup>3</sup> )	( <sup>3</sup> )
Poland <sup>6</sup> .....	383	( <sup>3</sup> )	( <sup>3</sup> )	( <sup>3</sup> )	5,428	( <sup>3</sup> )	( <sup>3</sup> )	( <sup>3</sup> )
Northern Caucasia <sup>6</sup> .....	11	( <sup>3</sup> )	( <sup>3</sup> )	( <sup>3</sup> )	89	( <sup>3</sup> )	( <sup>3</sup> )	( <sup>3</sup> )
Spain <sup>6</sup> .....	1,071	1,392	<sup>10</sup> 825	<sup>10</sup> 941	10,402	13,369	<sup>10</sup> 8,962	<sup>10</sup> 8,143
Sweden.....	47	55	25	35	1,227	1,123	843	1,885
United Kingdom:								
England.....	152	84	102	127	3,974	2,072	2,203	3,496
Wales.....	1	( <sup>4</sup> )	1	1	14	9	12	15
Scotland.....	1	( <sup>4</sup> )	( <sup>4</sup> )	( <sup>4</sup> )	14	3	1	2
Ireland.....		( <sup>4</sup> )	( <sup>4</sup> )	( <sup>4</sup> )	8	4	8	12
Total, United Kingdom.....	154	84	103	128	4,010	2,088	2,224	3,525
ASIA.								
Japan.....	91	126	222	( <sup>3</sup> )	1,804	2,329	3,898	( <sup>3</sup> )
Russia (9 governments) <sup>6</sup> .....	94	( <sup>3</sup> )	( <sup>3</sup> )	( <sup>3</sup> )	794	( <sup>3</sup> )	( <sup>3</sup> )	( <sup>3</sup> )
AUSTRALASIA.								
Australia.....	( <sup>8</sup> )	25	32	( <sup>3</sup> )	( <sup>8</sup> )	404	567	( <sup>3</sup> )
New Zealand.....	16	9	12	( <sup>3</sup> )	507	168	242	( <sup>3</sup> )

<sup>1</sup> Five-year average except where statistics were not available.  
<sup>2</sup> Census of 1909.  
<sup>3</sup> No official statistics.  
<sup>4</sup> Less than 500 acres.  
<sup>5</sup> Includes chick-peas, lentils, and vetches.  
<sup>6</sup> Old boundaries.  
<sup>7</sup> Includes lentils.  
<sup>8</sup> Included under beans.  
<sup>9</sup> Excludes territory occupied by the enemy.  
<sup>10</sup> Unofficial estimate.

## BROOM CORN.

TABLE 177.—*Broom corn: Acreage, production, and value, by States 1919, and totals 1915-1919.*

[Leading producing States.]

State and year.	Acreage.	Average yield per acre.	Production.	Average farm price per ton Nov. 15.	Farm value Nov. 15.
	<i>Acres.</i>	<i>Tons.</i>	<i>Tons.</i>	<i>Dollars.</i>	<i>Dollars.</i>
Illinois.....	15,200	.275	4,200	270.00	1,134,000
Missouri.....	4,400	.205	900	170.00	153,000
Kansas.....	20,000	.167	3,300	150.00	495,000
Texas.....	58,000	.186	10,800	140.00	1,512,000
Oklahoma.....	137,000	.196	26,900	149.00	4,008,000
Colorado.....	17,000	.175	3,000	100.00	300,000
New Mexico.....	20,000	.200	4,000	125.00	500,000
Total.....	271,600	.196	53,100	152.58	8,102,000
1918.....	366,000	.158	57,800	220.93	12,770,000
1917.....	345,000	.166	57,400	292.75	16,804,000
1916.....	235,200	.165	38,726	172.75	6,690,000
1915.....	230,100	.227	52,242	91.67	4,789,000

TABLE 178.—*Broom corn: Farm price per ton on 15th of each month, 1910-1919.*

Date.	1919	1918	1917	1916	1915	1914	1913	1912	1911	1910
Jan. 15.....	\$169.41	\$249.39	\$184.08	\$103.97	\$66.26	\$94.38	\$48.89	\$99.96	\$31.46	\$189.85
Feb. 15.....	140.96	253.70	200.54	103.52	78.44	95.16	56.08	85.97	79.70	196.88
Mar. 15.....	173.73	242.47	212.24	103.81	68.42	91.36	56.97	99.36	77.96	199.63
Apr. 15.....	149.46	222.19	226.82	96.39	70.79	89.47	58.13	100.54	74.10	203.80
May 15.....	151.72	205.98	252.33	100.94	74.84	84.99	53.40	83.34	81.05	199.25
June 15.....	106.49	222.11	222.66	101.81	76.51	88.04	61.08	79.40	69.36	150.67
July 15.....	119.02	235.02	193.79	103.06	78.94	87.94	56.61	84.68	68.14	179.65
Aug. 15.....	123.64	231.68	307.66	119.79	82.96	91.44	90.58	83.12	72.07	142.43
Sept. 15.....	154.28	300.28	240.15	128.51	75.24	77.05	106.05	76.52	91.67	138.66
Oct. 15.....	161.86	265.23	269.85	167.52	86.44	66.53	101.85	70.40	121.47	107.94
Nov. 15.....	160.55	205.35	295.50	172.60	92.04	65.82	99.80	69.33	124.00	95.62
Dec. 15.....	162.86	171.63	279.55	171.94	101.19	58.21	92.32	57.07	108.20	93.01

## GRAIN SORGHUMS.

TABLE 179.—*Grain sorghums:<sup>1</sup> Acreage, production, and value, by States 1919, and totals 1915-1919.*

[Leading producing States.]

State and year.	Acreage.	Average yield per acre.	Production.	Average farm price per bushel Nov. 15.	Farm value Nov. 15.
	<i>Acres.</i>	<i>Bushels.</i>	<i>Bushels.</i>	<i>Cents.</i>	<i>Dollars.</i>
Kansas.....	1,040,000	17.2	17,888,000	150	26,832,000
Texas.....	1,798,000	33.0	59,334,000	110	65,267,000
Oklahoma.....	1,440,000	23.0	33,120,000	150	49,680,000
Colorado.....	149,000	14.5	2,160,000	120	2,592,000
New Mexico.....	238,000	30.0	7,140,000	130	9,282,000
Arizona.....	58,000	35.0	2,030,000	150	3,045,000
California.....	170,000	25.8	4,386,000	154	6,754,000
Total.....	4,893,000	25.8	126,058,000	129.7	163,452,000
1918.....	6,036,000	12.1	73,241,000	150.0	109,881,000
1917.....	5,153,000	11.9	61,409,000	161.9	99,433,000
1916.....	3,944,000	13.7	53,858,000	105.9	57,027,000
1915.....	4,153,000	27.6	114,460,000	44.7	51,157,000

<sup>1</sup> Kafirs, milo maize, feteritá.

GRAIN SORGHUMS—Continued.

TABLE 180.—Grain sorghums: Farm price, cents per bushel on 15th of month, 1916-1919.

Date.	1919	1918	1917	1916	Date.	1919	1918	1917	1916
Jan. 15.....	153.7	170.8	119.1	.....	July 15.....	175.9	165.0	214.0	62.8
Feb. 15.....	156.9	185.7	129.0	.....	Aug. 15.....	176.9	177.2	243.3	72.4
Mar. 15.....	150.9	193.5	147.0	.....	Sept. 15.....	153.7	181.0	187.7	83.8
Apr. 15.....	162.1	204.0	152.0	53.6	Oct. 15.....	139.7	175.9	174.1	80.8
May 15.....	173.6	211.0	188.0	58.2	Nov. 15.....	133.6	150.5	160.6	102.4
June 15.....	174.1	179.6	206.3	60.0	Dec. 15.....	144.3	154.8	166.7	101.5

PEANUTS.

TABLE 181.—Peanuts: Acreage, production, and value, by States 1919, and totals 1916-1919.

State and year.	Acreage.	Average yield per acre.	Production.	Average farm price per bushel Nov. 15.	Farm value Nov. 15.
	<i>Acres.</i>	<i>Bushels.</i>	<i>Bushels.</i>	<i>Cents.</i>	<i>Dollars.</i>
Virginia.....	139,000	38.0	5,282,000	273	14,420,000
North Carolina.....	116,000	41.0	4,756,000	244	11,605,000
South Carolina.....	13,000	45.0	585,000	292	1,708,000
Georgia.....	202,000	25.0	5,050,000	246	12,423,000
Florida.....	126,000	27.0	3,402,000	211	7,178,000
Missouri.....	400	38.0	15,000	275	41,000
Tennessee.....	11,000	35.0	385,000	221	851,000
Alabama.....	380,000	18.0	6,840,000	218	14,911,000
Mississippi.....	4,000	32.0	128,000	221	283,000
Louisiana.....	3,000	31.6	93,000	254	236,000
Texas.....	222,000	25.0	5,550,000	238	13,209,000
Oklahoma.....	16,000	32.0	512,000	277	1,418,000
Arkansas.....	19,000	35.0	665,000	234	1,556,000
Total.....	1,251,400	26.6	33,263,000	240.0	79,839,000
1918.....	1,865,400	24.7	46,010,000	173.7	79,929,000
1917.....	1,842,400	28.5	52,505,000	174.3	91,498,000
1916.....	1,043,350	33.0	34,433,500	120.1	41,357,000

TABLE 182.—Peanuts: Farm price, cents per pound on 15th of each month, 1910-1919.

Date.	1919	1918	1917	1916	1915	1914	1913	1912	1911	1910
Jan. 15.....	6.0	7.0	4.9	4.3	4.5	4.7	4.6	4.3	4.4	4.9
Feb. 15.....	6.9	7.2	5.3	4.4	4.4	4.7	4.5	4.7	5.0	5.4
Mar. 15.....	7.0	7.4	5.5	4.4	4.2	4.7	4.7	5.0	4.8	5.0
Apr. 15.....	6.9	8.3	6.2	4.6	4.5	4.9	4.8	4.9	4.9	5.4
May 15.....	7.2	8.2	7.2	4.6	4.8	5.1	4.7	4.9	4.8	5.2
June 15.....	7.7	7.9	7.7	4.7	4.8	5.1	5.0	5.2	5.2	5.4
July 15.....	8.2	7.8	7.6	4.6	4.7	5.2	5.1	4.9	5.0	5.2
Aug. 15.....	8.1	7.9	7.2	4.6	4.5	4.9	4.9	5.0	5.3	4.5
Sept. 15.....	8.3	8.3	6.6	4.4	4.4	5.0	4.9	4.8	5.1	4.5
Oct. 15.....	8.1	6.9	6.1	4.4	4.3	4.5	4.8	4.7	4.6	4.6
Nov. 15.....	9.1	6.6	7.1	4.4	4.2	4.4	4.4	4.7	4.4	4.7
Dec. 15.....	9.1	6.1	7.1	4.7	4.2	4.3	4.8	4.6	4.4	4.5

## PEANUTS—Continued.

TABLE 183.—Peanuts: Area and production in Spain, British, India, Japan, and Formosa, and exports from Senegal.

[From official reports.]

## SPAIN.

Year.	Area.	Production.	Year.	Area.	Production.
	<i>Acres.</i>	<i>Tons of 2,000 pounds.</i>		<i>Acres.</i>	<i>Tons of 2,000 pounds.</i>
1912.....	18,434	21,620	1916.....	11,490	12,800
1913.....	18,656	19,626	1917.....	11,663	14,273
1914.....	18,928	22,319	1918.....	19,546	24,324
1915.....	14,429	13,834			

## BRITISH INDIA.

		<i>Tons of 2,240 pounds.</i>			<i>Tons of 2,240 pounds.</i>
1912.....	1,214,100	605,700	1916.....	1,673,000	1,058,000
1913.....	1,366,400	669,900	1917.....	2,334,000	1,196,000
1914.....	2,105,900	748,800	1918.....	1,894,000	1,042,000
1915.....	2,413,000	947,000	1919.....	1,312,000	490,000

## JAPAN.

		<i>Winchester bushels.</i>			<i>Winchester bushels.</i>
1911.....	19,140	1,568,323	1915.....	24,767	2,064,534
1912.....	24,622	2,002,681	1916.....	30,092	2,453,091
1913.....	22,539	2,203,750	1917.....	32,990	2,335,984
1914.....	23,350	2,216,271			

## FORMOSA.

		<i>Winchester bushels.</i>			<i>Winchester bushels.</i>
1911.....	44,836	880,304	1915.....	50,512	1,224,623
1912.....	44,503	838,308	1916.....	51,599	1,181,655
1913.....	46,518	1,125,893	1917.....	53,361	1,401,280
1914.....	47,627	1,006,953			

## QUANTITY AND VALUE OF PEANUTS EXPORTED FROM SENEGAL.

	<i>Tons of 2,000 pounds.</i>	<i>Dollars.</i>		<i>Tons of 2,000 pounds.</i>	<i>Dollars.</i>
1911.....	181,778	7,902,182	1914.....	309,224	13,488,637
1912.....	203,663	7,944,452	1915.....	334,071	10,865,718
1913.....	253,487	11,054,810			

TRUCK CROPS.

TABLE 184.—Commercial acreage and production of truck crops in the United States for the years 1917 and 1918. (Revised March 13, 1920.)

Crop.	Number of States producing.	Acreage.		Production.		Unit of measure.
		1917	1918	1917	1918	
Asparagus.....	24	31,647	26,459	36,289	28,004	Tons.
Beans (snap).....	33	31,104	31,618	54,156	56,859	Do.
Cabbage.....	28	93,518	92,715	603,962	684,812	Do.
Cantaloupes.....	16	60,150	39,650	8,006,500	5,796,000	Standard crates.
Cauliflower.....	20	9,086	9,972	1,898,974	2,084,148	Crates. <sup>1</sup>
Celery.....	7	14,500	14,750	6,597,750	6,436,560	Do. <sup>2</sup>
Corn (sweet).....	28	201,645	278,480	377,688	511,869	Tons.
Cucumbers.....	23	50,521	63,005	42,581	111,711	Do.
Lettuce.....	8	12,500	15,350	6,348,300	7,476,900	Crates. <sup>3</sup>
Onions.....	22	64,460	64,715	19,133,000	19,336,000	Bushels.
Peas.....	32	189,407	127,611	152,462	132,769	Tons.
Potatoes (early Irish).....	16	267,850	258,650	18,552,300	27,471,750	Bushels.
Strawberries.....	23	109,510	83,820	7,948,141	5,152,605	Crates. <sup>4</sup>
Tomatoes.....	42	30,850	351,252	1,074,596	1,462,869	Tons.
Watermelons.....	17	120,700	67,745	44,964,000	27,533,000	Number.
Total.....		1,548,448	1,525,792			

<sup>1</sup> Crates of 1 dozen heads each.

<sup>2</sup> Crates of 10 bunches of 1 dozen plants each.

<sup>3</sup> Crates of 2 dozen heads each.

<sup>4</sup> Crates containing 24 quarts.

CABBAGE.

TABLE 185.—Commercial acreage, yield per acre, and production of cabbages in the United States, 1915-1919. (Unrevised.)

State.	Acreage harvested.					Yield per acre.					Production in cars—25,000 pounds.				
	1915	1916	1917	1918	1919	1915	1916	1917	1918	1919	1915	1916	1917	1918	1919
Early:	<i>Acres</i>	<i>Acres</i>	<i>Acres</i>	<i>Acres</i>	<i>Acres</i>	<i>Tons</i>	<i>Tons</i>	<i>Tons</i>	<i>Tons</i>	<i>Tons</i>	<i>Cars.</i>	<i>Cars.</i>	<i>Cars.</i>	<i>Cars.</i>	<i>Cars.</i>
Calif.....	3,500	3,600	3,800	4,300	5,160	8.5	8.5	7.0	5.0	4.0	2,384	2,448	2,128	1,720	1,651
Fla.....	3,400	4,500	5,700	9,200	3,950	7.6	7.6	2.0	5.3	6.0	2,064	2,736	912	3,901	1,896
La. <sup>1</sup> .....	1,500	1,600	1,600	1,200	1,980	5.0	5.0	2.0	3.0	4.0	600	640	256	288	634
Tex.....	4,100	4,400	8,900	6,650	4,430	3.3	3.3	2.0	0.8	5.0	1,080	1,160	1,424	425	1,772
Late:															
Ala.....	1,100	1,000	1,000	1,500	1,380	8.3	8.3	3.0	7.8	7.0	728	664	160	936	773
Colo.....	3,700	3,200	3,300	4,220	3,420	10.8	10.3	12.9	9.0	10.0	3,197	2,637	3,406	3,038	2,736
Idaho.....	32	35	30	35	35	9.0	8.5	8.6	7.5	10.0	23	24	20	21	28
Ill.....	325	375	235	225	170	8.0	7.5	7.8	8.0	5.0	208	225	147	144	68
Ind.....	1,300	1,100	1,300	1,400	830	5.0	3.5	9.5	8.2	6.3	520	308	988	918	418
Iowa.....	2,800	1,700	1,000	1,800	1,170	10.0	6.5	7.2	7.0	4.5	2,240	884	576	1,008	421
Ky.....	300	350	250	200	200	9.3	9.5	8.7	9.2	8.6	223	266	174	147	136
Md.....	1,565	1,584	340	180	470	8.0	8.5	8.5	8.4	8.0	1,001	1,077	231	121	301
Mich.....	4,600	2,400	5,100	3,750	1,440	9.0	7.1	8.3	10.2	6.8	3,312	1,363	3,386	3,101	783
Minn.....	2,300	1,500	2,500	1,650	1,740	9.0	6.4	9.5	9.3	8.0	1,656	768	1,900	1,227	1,113
Miss.....	1,200	1,200	2,100	2,600	1,450	4.3	4.3	3.0	5.7	5.5	416	416	504	1,186	638
Mo.....	185	115	125	105	250	7.3	8.3	7.5	9.4	8.0	79	76	75	79	160
Nebr.....	65	55	25	25	25	7.3	8.3	7.0	9.2	9.0	38	36	14	18	18
N. J.....	1,650	1,695	1,620	1,500	1,390	8.0	9.2	8.6	8.7	7.5	1,056	1,248	1,115	1,044	834
N. Y.....	35,900	17,800	28,300	28,000	20,120	10.0	5.4	7.3	9.1	6.5	28,720	7,690	16,527	20,384	10,462
N. C.....	500	550	350	400	280	9.0	9.0	4.5	5.0	3.5	260	396	126	160	78
Ohio.....	3,900	2,200	3,500	3,080	2,030	7.0	5.3	8.3	7.0	7.0	2,184	933	2,324	1,736	1,137
Oreg.....	175	200	195	275	275	9.0	9.5	8.0	7.0	11.0	126	152	125	154	242
Pa.....	650	555	350	275	320	10.0	5.0	7.0	9.0	8.0	520	222	196	198	205
S. C.....	2,300	2,300	3,100	3,500	2,060	9.0	9.0	3.0	8.0	7.5	1,656	1,656	744	2,240	1,236
Tenn.....	250	275	300	310	420	8.6	8.2	8.0	8.8	6.0	172	180	192	218	201
Utah.....	18	20	23	25	25	8.5	8.2	8.5	7.5	10.0	12	13	16	15	20
Va:															
E. Shore and Norfolk sec.	4,750	5,050	4,350	3,050	2,475	9.2	9.2	4.6	7.3	6.5	3,504	3,714	1,620	1,780	1,287
SW.....	1,400	1,700	2,150	1,500	1,520	9.0	7.1	6.8	8.9	7.5	1,008	966	1,170	1,068	912
Wash.....	165	185	175	260	260	9.2	8.6	8.6	7.2	10.0	121	127	120	150	208
Wis.....	13,500	9,200	11,800	11,500	8,860	9.9	6.3	8.2	8.0	7.2	10,692	4,637	7,741	7,360	5,104

<sup>1</sup> New Orleans section.

## CABBAGE—Continued.

TABLE 186.—Cabbage: Farm price, per 100 pounds on 15th of each month, 1910-1919.

Date.	1919	1918	1917	1916	1915	1914	1913	1912	1911	1910
Jan. 15.....	\$2.19	\$2.74	\$3.95	\$1.17	\$1.36	\$1.87	\$1.26	\$1.89	\$1.56	\$1.87
Feb. 15.....	2.33	3.26	5.05	1.21	1.41	2.07	1.17	2.24	1.48	2.05
Mar. 15.....	2.71	2.86	6.77	1.38	1.38	2.03	1.03	2.88	1.26	2.14
Apr. 15.....	3.79	2.98	7.61	1.50	1.99	2.24	1.15	3.17	1.33	2.29
May 15.....	4.97	3.23	7.53	1.93	2.53	2.05	1.58	2.98	1.38	2.77
June 15.....	4.68	3.55	5.10	2.27	2.34	2.61	2.18	2.67	2.46	2.19
July 15.....	4.23	3.41	3.23	2.15	1.95	2.66	2.64	2.29	2.03	2.27
Aug. 15.....	3.73	2.96	2.19	2.26	1.61	1.74	2.15	1.88	2.47	1.89
Sept. 15.....	3.08	2.45	1.76	2.17	1.24	1.50	1.79	1.25	1.94	1.94
Oct. 15.....	2.88	2.16	1.79	2.40	1.00	1.31	1.69	1.08	1.58	1.58
Nov. 15.....	2.74	1.99	2.66	2.61	.97	1.14	1.58	1.04	1.51	1.36
Dec. 15.....	3.49	2.05	2.28	3.04	1.07	1.26	1.75	1.15	1.83	1.49

## ONIONS.

TABLE 187.—Commercial acreage, yield per acre, and production of onions in the United States, 1915-1919. (Unrevised.)

State.	Acreage harvested.					Yield per acre.					Production (cars of 500 bushels each).				
	1915	1916	1917	1918	1919	1915	1916	1917	1918	1919	1915	1916	1917	1918	1919
Early crop:	<i>Acres.</i>	<i>Acres.</i>	<i>Acres.</i>	<i>Acres.</i>	<i>Acres.</i>	<i>Bu.</i>	<i>Bu.</i>	<i>Bu.</i>	<i>Bu.</i>	<i>Bu.</i>	<i>Cars.</i>	<i>Cars.</i>	<i>Cars.</i>	<i>Cars.</i>	<i>Cars.</i>
Calif.....	650	900	1,250	1,400	870	325	320	340	330	311	422	576	850	932	541
La.....	2,000	3,000	3,000	1,500	350	175	165	185	190	160	700	990	1,110	570	112
Tex.....	8,943	10,057	12,050	18,070	6,630	237	225	265	144	210	4,238	4,525	6,386	5,204	3,182
Late crop:															
Calif.....	5,100	5,300	8,600	8,200	7,570	375	348	394	350	325	3,826	3,689	6,777	5,740	4,920
Colo.....	388	400	850	1,350	550	391	270	266	244	250	304	200	452	657	271
Idaho.....	175	200	450	30	75	400	500	400	575	500	140	216	360	34	75
Ill.....	900	850	1,000	1,100	830	215	225	275	345	200	386	383	550	758	332
Ind.....	3,070	3,600	4,250	2,950	3,450	184	206	293	362	200	1,129	1,483	2,490	2,136	1,380
Iowa.....	527	565	1,100	1,100	950	400	287	315	365	300	421	324	693	781	570
Ky.....	950	1,100	1,000	850	1,200	227	232	225	301	300	431	510	450	511	720
Mass.....	3,923	3,800	4,150	4,600	4,250	316	340	344	475	340	2,714	2,584	2,855	4,369	2,890
Mich.....	933	750	1,500	1,200	1,100	240	266	304	414	175	448	398	912	993	385
Minn.....	1,027	1,000	1,450	1,350	1,250	375	206	388	416	275	770	412	1,126	1,123	675
Nev.....	25	55	15	25	25	225	184	245	265	350	11	20	7	13	17
N. J.....	2,185	2,900	2,450	2,000	2,000	320	275	348	320	250	1,398	1,595	1,705	1,280	1,000
N. Y.....	12,551	6,600	9,800	8,650	7,280	287	195	278	408	265	7,205	2,574	5,448	7,058	3,858
Ohio.....	2,667	5,200	6,600	6,060	5,300	102	277	258	312	250	544	2,881	3,403	3,781	2,650
Oreg.....	691	750	1,050	750	800	400	500	256	235	300	553	750	537	352	480
Pa.....	401	250	350	200	120	250	300	269	283	300	202	150	188	114	72
Tex.....			875	950	1,100			200	250	250			349	475	550
Utah.....	75	90	100	100	65	400	400	400	510	500	60	72	80	102	65
Va. (E.S.)	1,169	375	426	380	300	200	200	214	265	250	468	154	182	202	150
Wash.....	781	800	1,200	1,000	640	400	492	313	400	400	624	787	751	800	512
Wis.....	817	950	950	900	930	350	228	318	382	140	572	433	605	687	260

<sup>1</sup> Does not include acreage grown under contract with seedsmen.

TABLE 188.—Onions: Farm price, cents per bushel on 15th of each month, 1910-1919.

Date.	1919	1918	1917	1916	1915	1914	1913	1912	1911	1910
Jan. 15.....	133.5	178.9	208.4	113.2	88.9	121.0	81.6	117.0	101.0	94.4
Feb. 15.....	154.7	183.2	357.9	126.3	97.6	140.7	77.5	140.0	104.0	100.1
Mar. 15.....	199.8	147.0	476.2	130.3	95.3	155.2	77.0	167.0	105.0	92.5
Apr. 15.....	202.1	134.1	495.6	123.5	104.4	159.2	79.0	175.0	119.0	103.4
May 15.....	229.9	134.7	398.0	123.3	102.9	152.0	87.2	177.0	129.0	102.8
June 15.....	234.1	138.7	308.0	133.8	102.9	140.8	95.0	155.0	134.0	105.8
July 15.....	232.0	162.6	201.0	147.3	93.0	170.4	101.7	114.0	122.0	104.5
Aug. 15.....	225.8	164.7	154.7	133.5	86.3	137.9	105.1	100.0	116.0	99.8
Sept. 15.....	195.4	163.3	142.9	122.9	82.8	103.3	103.9	89.0	104.0	99.4
Oct. 15.....	196.4	143.2	157.5	131.4	94.8	88.3	110.2	85.0	102.0	93.2
Nov. 15.....	212.5	143.1	176.6	153.8	94.8	84.4	114.9	84.0	103.0	94.6
Dec. 15.....	245.8	131.7	177.0	175.7	99.6	92.3	114.9	81.0	113.0	98.8



TOMATOES.

TABLE 189.—Commercial acreage, yield per acre, and production of tomatoes for manufacture and table stock, 1917-1919. (Unrevised.)

States.	Acreage harvested.						Yield per acre.						Production.					
	1917		1918		1919 (preliminary).		1917		1918		1919 (preliminary).		1917		1918		1919 (preliminary).	
	Table stock.	Manu- facture stock.	Table stock.	Manu- facture stock.	Table stock.	Manu- facture stock.	Table stock.	Manu- facture stock.	Table stock.	Manu- facture stock.	Table stock.	Manu- facture stock.	Table stock.	Manu- facture stock.	Table stock.	Manu- facture stock.	Table stock.	Manu- facture stock.
<i>Acres.</i>	<i>Acres.</i>	<i>Acres.</i>	<i>Acres.</i>	<i>Acres.</i>	<i>Acres.</i>	<i>Tons.</i>	<i>Tons.</i>	<i>Tons.</i>	<i>Tons.</i>	<i>Tons.</i>	<i>Tons.</i>	<i>Tons.</i>	<i>Cases.<sup>1</sup></i>	<i>Tons.</i>	<i>Cases.<sup>1</sup></i>	<i>Tons.</i>	<i>Cases.<sup>1</sup></i>	
Alabama.....	0	25	0	25	0	15	3.0	3.0	3.0	0	1,650	0	1,725	0	0	0	0	
Arkansas.....	0	1,824	0	5,354	0	3,740	3.3	2.3	3.8	0	117,634	0	235,197	0	0	0	0	
California.....	2,319	23,735	2,200	18,559	2,200	30,699	7.5	7.5	5.4	5.4	7.9	7.9	17,390	3,260,620	11,880	5,094,963	17,380	1,736,207
Colorado.....	0	1,294	0	1,358	0	1,940	11.8	7.6	8.2	0	321,134	0	226,030	0	0	0	( <sup>3</sup> )	
Connecticut.....	0	118	0	190	0	178	3.0	4.7	6.6	0	7,788	0	17,484	0	0	0	0	
Delaware.....	0	22,483	0	10,186	0	4,498	3.2	3.8	1.9	0	1,262,404	0	1,022,385	0	0	0	123,070	
Florida.....	25,830	20	15,600	625	20,900	0	2.9	3.0	3.0	2.0	2.8	77,480	1,320	46,800	17,500	58,520	0	
Georgia.....	0	0	0	10	0	0	6.0	2.0	2.8	0	0	0	280	0	0	0	0	
Idaho.....	0	70	0	31	0	61	6.0	4.0	3.0	0	9,240	0	2,728	0	0	0	0	
Illinois.....	0	4,009	0	1,039	0	3,193	3.3	3.2	3.9	0	222,046	0	69,598	0	0	0	( <sup>3</sup> )	
Indiana.....	0	32,161	0	19,812	0	30,681	2.6	3.7	4.9	0	498,784	0	1,242,580	0	0	0	609,973	
Iowa.....	0	1,883	0	780	0	2,060	2.5	1.9	5.2	0	93,720	0	32,648	0	0	0	2 160,405	
Kansas.....	0	5	0	114	0	0	3.0	2.6	0	0	330	0	6,512	0	0	0	0	
Kentucky.....	0	2,540	0	7,306	0	3,159	2.7	1.1	3.7	0	106,502	0	180,236	0	0	0	( <sup>4</sup> )	
Louisiana.....	0	105	0	0	0	17	5.0	3.0	3.0	0	11,550	0	0	0	0	0	0	
Maryland.....	0	64,444	0	46,353	0	28,372	3.0	4.6	1.9	0	4,031,478	0	6,363,006	0	0	0	1,462,884	
Massachusetts.....	0	8	0	10	0	10	3.0	4.0	3.0	0	528	0	1,540	0	0	0	0	
Michigan.....	0	3,329	0	2,657	0	1,354	1.3	4.6	6.8	0	26,202	0	228,882	0	0	0	( <sup>3</sup> )	
Minnesota.....	0	37	0	0	0	10	2.2	5.8	0	0	1,782	0	0	0	0	0	( <sup>3</sup> )	
Mississippi.....	7,130	0	4,700	0	4,600	0	2.2	4.5	4.0	15,680	0	21,150	18,400	0	0	0	0	
Missouri.....	0	10,943	0	13,142	0	9,959	3.5	2.2	3.7	0	842,600	0	631,433	0	0	0	504,534	
Nebraska.....	0	58	0	66	0	75	3.3	2.6	2.6	0	4,202	0	3,526	0	0	0	0	
New Hampshire.....	0	10	0	0	0	0	3.0	0	0	0	660	0	0	0	0	0	0	
New Jersey.....	11,200	24,943	4,650	8,679	4,950	18,811	4.3	4.3	7.2	5.1	2.6	3.1	48,320	831,468	33,480	968,551	12,870	269,825
New Mexico.....	0	300	0	1,062	0	440	5.0	2.0	2.6	0	33,000	0	46,728	0	0	0	0	
New York.....	0	8,584	0	5,131	0	6,302	2.5	5.6	7.1	0	240,438	0	523,416	0	0	0	289,010	
North Carolina.....	0	118	0	177	0	125	3.0	1.9	2.0	0	7,788	0	9,372	0	0	0	0	
Ohio.....	0	3,673	0	5,398	0	6,800	2.1	3.6	6.9	0	215,204	0	372,514	0	0	0	275,108	
Oklahoma.....	0	100	0	130	0	40	3.0	2.6	2.6	0	6,600	0	6,760	0	0	0	0	
Oregon.....	0	125	0	235	0	55	8.0	7.7	7.7	0	22,000	0	55,692	0	0	0	0	
Pennsylvania.....	0	3,972	0	1,627	0	1,511	2.4	1.8	5.2	0	135,762	0	92,198	0	0	0	4 225,130	
South Carolina.....	0	192	0	12	0	2	3.0	2.0	2.0	0	6,732	0	704	0	0	0	0	
South Dakota.....	0	30	0	31	0	0	3.0	2.0	0	0	1,980	0	1,264	0	0	0	0	

Statistics of Tomatoes.

TOMATOES—Continued.

TABLE 189.—Commercial acreage, yield per acre, and production of tomatoes for manufacture and table stock, 1917–1919. (Unrevised.)—Continued.

States.	Acreage harvested.						Yield per acre.						Production.					
	1917		1918		1919 (preliminary).		1917		1918		1919 (preliminary).		1917		1918		1919 (preliminary).	
	Table stock.	Manu- facture stock.	Table stock.	Manu- facture stock.	Table stock.	Manu- facture stock.	Table stock.	Manu- facture stock.	Table stock.	Manu- facture stock.	Table stock.	Manu- facture stock.	Table stock.	Manu- facture stock.	Table stock.	Manu- facture stock.	Table stock.	Manu- facture stock.
Acres.		Acres.		Acres.		Tons.		Tons.		Tons.		Tons.		Cases. <sup>1</sup>		Cases. <sup>1</sup>		
Tennessee.....	1,000	3,454	3,000	5,934	3,000	4,084	3.0	3.0	3.5	3.5	2.0	3.3	3,020	213,180	10,500	430,464	6,000	( <sup>4</sup> )
Texas.....	5,480	40	4,000	120	5,900	0	2.6	3.0	4.0	3.0	3.0	3.0	16,430	2,640	16,000	11,110	17,700	.....
Utah.....	0	3,191	0	4,449	0	3,897	.....	9.0	.....	11.2	.....	8.5	0	552,948	0	1,089,516	0	685,828
Virginia.....	0	22,354	0	25,105	0	18,157	.....	3.3	.....	3.5	.....	2.6	0	1,613,040	0	1,946,169	0	<sup>5</sup> 789,118
Washington.....	0	5	0	133	0	10	.....	8.0	.....	4.4	.....	10.9	0	880	0	12,870	0	<sup>2</sup> 309,291
West Virginia.....	0	1,481	0	1,342	0	872	.....	1.8	.....	2.1	.....	2.2	0	58,652	0	57,236	0	( <sup>5</sup> )
Wisconsin.....	0	288	0	321	0	291	.....	3.8	.....	0.9	.....	6.8	0	24,068	0	6,387	0	.....
All other.....	.....	.....	.....	.....	.....	.....	.....	.....	.....	.....	.....	.....	0	0	0	.....	0	255,545
Total.....	52,989	247,861	34,150	187,503	41,550	181,418	3.2	3.6	4.1	4.1	3.1	5.2	178,320	14,788,554	139,810	19,009,309	130,870	7,692,933

<sup>1</sup> Cases of No. 3's.  
<sup>2</sup> Report for Washington includes Colorado.  
<sup>3</sup> Report for Iowa includes Michigan, Illinois, and Minnesota.  
<sup>4</sup> Report for Pennsylvania includes Kentucky and Tennessee.  
<sup>5</sup> Report for Virginia includes West Virginia.

TOMATOES—Continued.

TABLE 190.—Tomatoes: Farm price, cents per bushel, 15th of month, 1912-1919.

Date.	1919	1918	1917	1916	1915	1914	1913	1912
July 15.....	240.3	219.1	194.3	161.5	141.4	167.4	161.4	127.0
Aug. 15.....	177.0	133.1	124.3	88.4	66.4	92.5	95.8	75.6
Sept. 15.....	137.2	103.0	109.5	75.6	56.9	63.0	68.0	58.7
Oct. 15.....	117.7	108.6	117.6	82.1	67.9	60.3	73.0	62.3

TURNIPS.

TABLE 191.—Turnips: Farm price, cents per bushel, 15th of month, 1912-1919.

Date.	1919	1918	1917	1916	1915	1914	1913	1912
Jan. 15.....	82.1	88.4	78.6	48.6	42.9	56.8	49.6	.....
Feb. 15.....	84.7	89.9	91.1	49.6	51.1	60.0	51.2	.....
Nov. 15.....	98.9	79.6	76.4	68.4	45.9	47.4	56.1	44.6
Dec. 15.....	101.8	79.0	81.1	73.3	45.1	48.4	55.1	49.1

SUGAR.

TABLE 192.—Sugar: Production in the United States and its possessions, 1856-57 to 1918-19.<sup>1</sup>

[Data for 1912-13 and subsequently beet sugar, also Louisiana and Hawaii cane sugar, estimated by United States Department of Agriculture; Porto Rico, by Treasury Department of Porto Rico; Philippine Islands, production estimated by the Philippine Department of Agriculture and exports for years ending June 30. For sources of data for earlier years, see Yearbook for 1912, p. 650. A short ton is 2,000 pounds.]

Year.	Beet sugar (chiefly refined).	Cane sugar (chiefly raw).					Total.
		Louisiana.	Other States. <sup>2</sup>	Porto Rico.	Hawaii.	Philippine Islands. <sup>3</sup>	
Average:	Short tons.	Short tons.	Short tons.	Short tons.	Short tons.	Short tons.	Short tons.
1856-7 to 1860-61.....	.....	132,402	5,978	75,364	.....	46,446	260,190
1861-62 to 1865-66.....	269	74,036	1,945	71,765	.....	54,488	202,503
1866-67 to 1870-71.....	448	44,768	3,818	96,114	.....	81,485	226,633
1871-72 to 1875-76.....	403	67,341	4,113	87,606	( <sup>4</sup> )	119,557	279,020
1876-77 to 1880-81.....	470	104,920	5,327	76,579	27,040	169,067	383,403
1881-82 to 1885-86.....	692	124,868	7,280	87,441	76,075	189,277	485,633
1886-87 to 1890-91.....	1,922	163,049	8,439	70,112	125,440	186,129	555,091
1891-92 to 1895-96.....	19,406	268,655	6,634	63,280	162,538	286,629	807,142
1896-97 to 1900-1901.....	58,287	282,399	4,405	61,292	282,585	134,722	823,690
1901-2 to 1905-6.....	239,730	352,053	12,126	141,478	403,308	108,978	1,257,673
1906-7 to 1910-11.....	479,153	348,544	13,664	282,136	516,041	145,832	1,785,370
1901-2.....	184,606	360,277	4,048	103,152	355,611	75,011	1,082,705
1902-3.....	218,406	368,734	4,169	100,576	437,991	123,108	1,252,984
1903-4.....	240,604	255,894	22,176	138,096	367,475	82,855	1,107,100
1904-5.....	242,113	398,195	16,800	151,088	426,248	125,271	1,359,715
1905-6.....	312,921	377,162	13,440	214,480	429,213	138,645	1,485,861
1906-7.....	483,612	257,600	14,560	206,864	440,017	132,602	1,535,255
1907-8.....	463,628	380,800	13,440	230,095	521,123	167,242	1,776,328
1908-9.....	425,884	397,600	16,800	277,093	535,156	123,876	1,776,409
1909-10.....	512,469	364,000	11,200	346,786	517,090	140,783	1,892,328
1910-11.....	510,172	342,720	12,320	349,840	566,821	164,658	1,946,531
1911-12.....	599,500	352,874	8,000	371,076	595,038	205,046	2,131,534
1912-13.....	692,556	153,573	9,000	398,004	546,524	<sup>5</sup> 345,077	2,144,734
1913-14.....	733,401	292,698	7,800	351,666	612,000	<sup>5</sup> 408,339	2,405,904
1914-15.....	722,054	242,700	3,920	346,490	646,000	<sup>5</sup> 421,192	2,382,356
1915-16.....	874,220	137,500	1,120	483,590	592,763	<sup>5</sup> 412,274	2,501,467
1916-17.....	820,657	303,900	7,000	503,081	644,663	<sup>5</sup> 425,266	2,704,567
1917-18.....	765,207	243,600	2,240	462,819	576,700	<sup>5</sup> 399,033	.....
1918-19.....	760,950	263,450	3,500	.....	.....	.....	.....
1919-20.....	763,848	115,590	1,125	.....	.....	.....	.....

<sup>1</sup> Census returns give production of beet sugar for 1899 as 81,729 short tons; for 1904, 253,921; 1909, 501,682; production of cane sugar in Louisiana for 1839, 59,974 short tons; 1849, 226,001 hogsheads; 1859, 221,726 hogsheads; 1869, 80,706 hogsheads; 1879, 171,706 hogsheads; 1889, 146,062 short tons; 1898, 278,497 short tons; 1899, 159,583; and 1909, 325,516 short tons; cane sugar in other States, 1839, 491 short tons; in 1849, 21,576 hogsheads; in 1859, 9,256 hogsheads; in 1869, 6,337 hogsheads; in 1879, 7,166 hogsheads; in 1889, 4,580 short tons; in 1899, 1,691; and in 1909, 8,687 short tons.

<sup>2</sup> Includes Texas only, subsequent to 1902-3. Unofficial returns prior to 1918-19.

<sup>3</sup> Exports for years ending June 30.

<sup>4</sup> Complete data not available for this period. Production in 1878-79 1,254 short tons; in 1879-80, 1,304 short tons.

<sup>5</sup> Production.

## SUGAR—Continued.

TABLE 193.—*Sugar beets and beet sugar: Production in the United States, 1913–1919.*  
 [Figures for 1919 are subject to revision.]

State and year. <sup>1</sup>	Area of beets.			Beets produced (weight as delivered to factories).			
	Planted.	Harvested.		Quantity.	Yield per acre.	Farm value.	Price to growers per ton.
		Amount.	Per cent of planted.				
California:	<i>Acres.</i>	<i>Acres.</i>	<i>Per cent.</i>	<i>Short tons.</i>	<i>Short tons.</i>	<i>Dollars.</i>	<i>Dollars.</i>
1919.....	129,500	110,931	85.66	819,638	7.39	10,952,000	13.36
1918.....	120,900	100,684	83.28	858,028	8.52	8,534,000	9.95
1917.....	190,200	161,909	85.13	1,331,548	8.22	10,125,000	7.60
1916.....	159,100	141,097	88.68	1,477,426	10.47	9,311,000	6.30
Colorado:							
1919.....	236,300	184,770	78.19	1,790,099	9.69	18,061,000	10.09
1918.....	142,000	125,882	88.65	1,443,846	11.47	14,474,000	10.02
1917.....	183,600	161,476	87.95	1,857,649	11.50	13,526,000	7.28
1916.....	211,600	188,568	89.12	2,018,298	10.70	12,236,000	6.06
Idaho:							
1919.....	53,700	27,094	50.45	201,407	7.43	2,014,000	10.00
1918.....	37,700	32,306	85.69	344,334	10.66	3,443,000	10.00
1917.....	46,500	37,745	81.17	312,067	8.27	2,203,000	7.06
1916.....	48,500	42,135	86.87	357,137	8.48	2,199,000	6.16
Michigan:							
1919.....	166,100	121,498	73.15	1,108,908	9.13	12,504,000	11.28
1918.....	134,500	114,976	85.48	966,676	8.40	9,741,000	10.08
1917.....	112,700	82,151	72.89	524,195	6.38	4,215,000	8.04
1916.....	122,000	99,619	81.65	543,766	5.46	3,337,000	6.14
Nebraska:							
1919.....	64,800	59,756	92.22	580,284	9.71	5,781,000	9.96
1918.....	44,600	42,746	95.84	485,070	11.35	4,833,000	9.96
1917.....	55,500	51,337	92.50	473,494	9.22	3,417,000	7.22
1916.....	44,800	41,083	91.70	424,913	10.34	2,622,000	6.17
Ohio:							
1919.....	37,100	30,295	81.66	280,450	9.26	3,104,000	11.07
1918.....	36,100	32,547	90.16	315,371	9.69	3,162,000	10.03
1917.....	29,300	24,234	82.71	219,931	9.08	1,580,000	7.18
1916.....	32,600	24,767	75.97	147,718	5.96	1,008,000	6.83
Utah:							
1919.....	109,700	101,780	92.78	1,070,733	10.52	10,707,000	10.00
1918.....	90,100	81,717	90.70	1,003,013	12.27	10,041,000	10.01
1917.....	91,100	80,289	88.13	762,028	7.49	5,368,000	7.04
1916.....	77,400	68,211	88.13	798,119	11.70	4,577,000	5.73
Wisconsin:							
1919.....	16,200	13,500	83.33	143,500	10.63	1,603,000	11.17
1918.....	14,900	12,400	83.22	99,777	8.05	998,000	10.00
1917.....	14,100	9,800	69.50	79,372	8.10	699,000	8.81
1916.....	10,500	7,000	66.67	61,500	8.79	373,000	6.06
Other States:							
1919.....	77,000	46,879	60.88	401,841	8.57	4,024,000	10.01
1918.....	68,900	50,752	73.66	432,683	8.53	4,268,000	9.86
1917.....	83,600	55,856	66.81	420,093	7.52	3,059,000	7.28
1916.....	62,000	52,828	85.21	399,379	7.56	2,476,000	6.20
United States:							
1919.....	890,400	696,503	78.22	6,396,860	9.18	68,750,000	10.75
1918.....	689,700	594,010	86.13	5,948,798	10.01	59,494,000	10.00
1917.....	806,600	664,797	82.43	5,980,377	9.00	44,192,000	7.39
1916.....	768,500	665,308	86.57	6,228,256	9.36	38,139,000	6.12
1915.....	664,300	611,301	92.02	6,511,274	10.7	36,950,000	5.67
1914.....	514,600	483,400	93.94	5,585,000	11.6	30,438,000	5.45
1913.....	635,100	580,006	91.33	5,886,000	10.1	33,491,000	5.69

<sup>1</sup>In this table the acreage and production of beets are credited to the respective States in which the beets were made into sugar and not to the States in which the beets were actually produced.

SUGAR—Continued.

TABLE 194.—Sugar beets and beet sugar: Production in the United States, 1913–1919—Continued.

[Figures for 1919 are subject to revision.]

State and year. <sup>1</sup>	Factories operating.	Average length of campaign.	Sugar made (chiefly refined).	Sugar beets used.			Analysis of beets.		Recovery of sucrose. <sup>4</sup>		Loss. <sup>6</sup>
				Area harvested.	Average yield per acre.	Quantity worked (sliced).	Percentage of sucrose. <sup>2</sup>	Purity coefficient. <sup>3</sup>	Percentage of weight of beets.	Percentage of total sucrose in beets.	
	No.	Days.	Short tons.	Acres.	Short tons.	Short tons.	Per cent.	Per cent.	Per cent.	Per cent.	Per cent.
California:											
1919.....	11	.....	127,907	110,931	7.39	819,638	16.64	.....	15.61	93.81	1.03
1918.....	13	81	122,795	100,684	8.40	845,728	17.03	81.50	14.52	85.26	2.51
1917.....	14	92	209,325	161,909	8.16	1,321,716	18.48	82.91	15.84	85.71	2.64
1916.....	11	108	236,322	141,097	10.37	1,462,895	18.35	84.12	16.15	88.01	2.20
Colorado:											
1919.....	15	.....	198,881	184,770	9.69	1,790,099	13.86	.....	11.11	80.16	2.75
1918.....	14	76	191,880	125,882	10.83	1,363,277	16.10	85.96	14.07	87.39	2.03
1917.....	15	91	234,303	161,476	10.84	1,749,875	15.40	85.16	13.39	86.95	2.01
1916.....	14	102	252,147	188,568	10.25	1,933,591	15.00	85.79	13.04	86.93	1.96
Idaho:											
1919.....	6	.....	25,867	27,094	7.43	201,407	15.60	.....	12.84	82.31	2.76
1918.....	7	87	44,682	32,306	10.12	326,979	16.57	86.46	13.66	82.44	2.91
1917.....	7	70	38,376	37,745	7.59	286,446	16.74	84.84	13.40	80.05	3.34
1916.....	5	86	45,874	42,135	7.87	331,478	16.95	86.39	13.84	81.65	3.11
Michigan:											
1919.....	16	.....	132,268	121,498	9.13	1,108,908	14.65	.....	11.93	81.43	2.72
1918.....	16	75	127,979	114,976	7.74	890,238	16.61	85.49	14.38	86.51	2.23
1917.....	14	53	64,247	82,151	5.62	461,721	16.28	86.57	13.91	85.44	2.37
1916.....	15	49	69,341	99,619	5.05	502,705	16.37	85.22	13.79	84.24	2.58
Nebraska:											
1919.....	4	.....	65,550	59,756	9.71	580,284	13.72	.....	11.30	82.36	2.42
1918.....	4	99	63,494	42,746	10.60	453,266	16.05	86.14	14.01	87.29	2.04
1917.....	4	97	53,893	51,337	9.22	443,355	14.91	80.71	12.16	81.56	2.75
1916.....	3	107	51,945	41,083	10.34	404,017	15.51	81.12	12.86	82.91	2.65
Ohio:											
1919.....	5	.....	30,165	30,295	9.26	280,450	14.39	.....	10.76	74.77	3.63
1918.....	5	91	35,476	32,547	8.94	291,064	15.74	84.23	12.19	77.45	3.55
1917.....	5	70	24,467	24,234	8.36	202,624	16.24	86.25	12.08	74.38	4.16
1916.....	4	45	18,234	24,767	5.56	137,696	15.89	83.36	13.24	83.32	2.65
Utah:											
1919.....	18	.....	119,829	101,780	10.52	1,070,733	14.49	.....	11.19	77.23	3.30
1918.....	16	98	105,794	81,717	11.08	905,064	15.29	84.21	11.69	76.46	3.60
1917.....	15	82	83,662	80,289	8.68	696,522	15.61	82.27	12.01	76.94	3.60
1916.....	11	95	90,277	68,211	10.38	708,237	16.05	84.79	12.75	79.44	3.30
Wisconsin:											
1919.....	4	.....	13,849	13,500	10.63	143,500	12.92	.....	9.65	74.69	3.27
1918.....	4	61	13,358	12,400	7.54	93,467	16.29	82.40	14.29	87.72	2.00
1917.....	4	53	8,032	9,800	7.23	70,830	15.03	.....	11.34	75.45	3.69
1916.....	3	48	6,800	7,000	8.39	58,700	14.90	.....	11.58	77.72	3.32
Other States:											
1919 <sup>6</sup> .....	11	.....	49,532	46,879	8.57	401,841	15.08	.....	12.33	81.76	2.75
1918.....	10	64	55,492	50,752	8.05	408,423	15.95	84.31	13.59	85.20	2.36
1917.....	13	51	48,902	55,856	7.03	392,456	15.17	81.87	12.46	82.14	2.71
1916.....	8	57	49,717	52,828	7.20	380,354	15.69	82.67	13.07	83.30	2.62
United States:											
1919.....	90	.....	763,848	696,503	9.18	6,396,860	14.33	.....	11.94	83.32	2.39
1918.....	89	81	760,950	594,010	9.39	5,577,506	16.18	84.70	13.64	84.30	2.54
1917.....	91	74	765,207	664,797	8.46	5,625,545	16.28	83.89	13.60	83.54	2.68
1916.....	74	80	820,657	665,308	8.90	5,919,673	16.30	84.74	13.86	85.03	2.44
1915.....	67	92	874,220	611,301	10.10	6,150,293	16.49	84.38	14.21	86.17	2.28
1914.....	60	85	722,054	483,400	10.9	5,288,500	16.38	83.89	13.65	83.33	2.73
1913.....	71	85	733,401	580,006	8.76	5,659,462	15.78	83.22	12.96	82.13	2.82

<sup>1</sup> Acreage and production of beets are credited, as in former reports, to the State in which the beets were made into sugar.

<sup>2</sup> Based upon weight of beets.

<sup>3</sup> Percentage of sucrose (pure sugar) in the total soluble solids of the beets.

<sup>4</sup> Percentage of sucrose actually extracted by factories.

<sup>5</sup> Percentage of sucrose (based upon weight of beets) remaining in molasses and pulp.

<sup>6</sup> Includes 2 factories in Washington, 3 in Wyoming, and 1 each in Illinois, Indiana, Iowa, Kansas, Minnesota, and Montana.

## SUGAR—Continued.

TABLE 195.—Cane-sugar production of Louisiana, 1911–1919.

[Figures for 1919 are from returns made before the end of the season, and are subject to revision.]

Year of cane harvest.	Factories in operation.	Sugar made.	Average sugar made, per ton of cane.	Cane used for sugar.			Molasses made. <sup>1</sup>	
				Area.	Average per acre.	Production.	Total.	Per ton of sugar.
	<i>Number.</i>	<i>Short tons.</i>	<i>Pounds.</i>	<i>Acres.</i>	<i>Short tons.</i>	<i>Short tons.</i>	<i>Gallons.</i>	<i>Gallons.</i>
1911.....	188	352,874	120	310,000	19	5,887,292	35,062,525	99
1912.....	126	153,573	142	197,000	11	2,162,574	14,302,169	93
1913.....	153	292,698	139	248,000	17	4,214,000	24,046,320	82
1914.....	149	242,700	152	213,000	15	3,199,000	17,177,443	71
1915.....	136	137,500	135	183,000	11	2,018,000	12,743,000	93
1916.....	150	303,900	149	221,000	18	4,072,000	26,154,000	86
1917.....	140	243,600	128	244,000	15.6	3,813,000	30,728,000	126
1918.....	134	280,900	135	231,200	18	4,170,000	28,049,000	100
1919.....	.....	115,590	131	176,500	10	1,765,000	.....	.....

<sup>1</sup> Figures for molasses, 1911–1914, are as reported by the Louisiana Sugar Planters' Association; figures for later years as reported by Bureau of Crop Estimates, U. S. Department of Agriculture.

TABLE 196.—Area of sugar cane and production of cane sirup in the United States, 1918 and 1919.

[Not including sorghum.]

States.	Total cane area.		Area harvested for sirup.		Sirup made.	
	1919	1918	1919	1918	1919	1918
	<i>Acres.</i>	<i>Acres.</i>	<i>Acres.</i>	<i>Acres.</i>	<i>Gallons.</i>	<i>Gallons.</i>
South Carolina.....	7,700	7,200	7,400	7,000	1,369,000	959,000
Georgia.....	67,600	67,300	56,000	50,000	10,640,000	8,500,000
Florida.....	21,000	16,300	17,000	13,000	4,590,000	2,800,000
Alabama.....	62,500	61,000	51,000	56,000	8,480,000	8,195,000
Mississippi.....	31,400	30,500	26,700	23,500	6,675,000	4,740,000
Louisiana.....	275,000	303,000	20,800	27,500	3,874,000	10,793,000
Texas <sup>1</sup> .....	12,600	17,000	7,800	1,300	2,421,000	220,000
Arkansas.....	3,200	2,800	2,200	1,700	336,000	170,000
Total.....	481,000	505,100	188,900	180,000	38,385,000	36,377,000

<sup>1</sup> Texas had a poor crop in 1918, due to drought; and a good crop in 1919.

TABLE 197.—Total and per capita sugar supply of the United States, 1901–1919.

[The "supply" shown below consists of domestic production, plus imports, minus exports, and is quoted from the Statistical Abstract of the United States for 1918, pp. 560–561, for all years except 1919. Figures for 1919 are based upon the Bureau of Crop Estimates reports on production and the Bureau of Foreign and Domestic Commerce reports on exports and imports. The average per capita supply is computed from the Census estimates of population for June 1, each year. No allowance has been made for sugar carried over from one fiscal year to the next.]

Year ending June 30—	Supply ("consumption") of sugar.		Year ending June 30—	Supply ("consumption") of sugar.	
	Total.	Per capita.		Total.	Per capita.
	<i>Millions of pounds.</i>	<i>Pounds.</i>		<i>Millions of pounds.</i>	<i>Pounds.</i>
1901.....	5,585	71.96	1911.....	7,236	77.15
1902.....	5,019	63.35	1912.....	7,862	82.43
1903.....	6,380	78.92	1913.....	8,324	85.04
1904.....	5,662	68.66	1914.....	8,794	89.14
1905.....	6,026	71.66	1915.....	8,627	86.04
Annual average, 1901–1905.....	5,734	70.91	Annual average, 1911–1915.....	8,169	83.96
1906.....	6,491	75.74	1916.....	7,960	78.13
1907.....	7,090	81.19	1917.....	8,468	81.81
1908.....	6,591	74.11	1918.....	8,090	76.97
1909.....	7,283	80.43	1919 <sup>1</sup> .....	8,735	81.84
1910.....	7,360	79.90			
Annual average, 1906–1910.....	6,963	78.27			

<sup>1</sup> Preliminary.

SUGAR—Continued.

TABLE 198.—Cane-sugar production of Hawaii, 1913-1919.

[Figures for 1919 are subject to revision.]

Island, and year ending Sept. 30.	Average length of campaign.	Sugar made.	Cane used for sugar.			Total area in cane.	Average extraction of sugar.	
			Area harvested.	Average yield per acre.	Production.		Per cent of cane.	Per short ton of cane.
	Days.	Short tons.	Acres.	Short tons.	Short tons.	Acres.	Per cent.	Pounds.
<b>Hawaii:</b>								
1919.....	180	203,294	53,500	32	1,731,000	106,300	11.74	235
1918.....	171	162,900	52,700	28	1,498,000	130,800	10.87	217
1917.....	184	232,140	52,700	36	1,898,000	100,300	12.23	245
1916.....	179	197,130	52,627	33	1,713,759	98,787	11.50	230
1915.....	196	240,300	50,800	41	2,099,000	100,200	11.45	229
1914.....	174	213,000	51,000	36	1,854,000	.....	11.49	230
1913.....	170	197,212	53,600	32	1,703,000	.....	11.58	232
<b>Kauai:</b>								
1919.....	161	108,943	22,300	40	898,000	47,700	12.13	243
1918.....	162	137,800	21,400	48	1,037,000	48,600	13.29	265
1917.....	207	119,218	25,400	41	1,040,000	51,300	11.46	229
1916.....	191	108,632	21,392	43	927,970	51,712	11.71	234
1915.....	203	115,700	21,000	45	941,000	49,200	12.30	246
1914.....	214	121,000	21,600	50	1,089,000	.....	11.11	222
1913.....	198	100,340	20,800	42	841,000	.....	11.93	239
<b>Maui:</b>								
1919.....	169	132,990	20,000	47	939,000	40,500	14.16	283
1918.....	231	162,200	23,100	57	1,315,000	50,300	12.33	247
1917.....	160	147,755	23,600	47	1,108,000	49,300	13.33	267
1916.....	168	150,311	19,911	55	1,098,247	51,897	13.69	274
1915.....	174	160,300	19,800	57	1,126,000	44,400	14.24	285
1914.....	167	145,000	19,400	54	1,054,000	.....	13.76	275
1913.....	152	124,820	19,700	47	929,000	.....	13.44	269
<b>Oahu:</b>								
1919.....	204	155,085	23,900	49	1,176,000	45,400	13.19	264
1918.....	193	113,800	22,600	50	1,005,000	47,100	11.32	227
1917.....	214	145,550	22,200	53	1,174,000	44,200	12.39	248
1916.....	179	136,690	21,489	52	1,119,448	43,936	12.21	244
1915.....	205	129,700	21,600	47	1,019,000	46,000	12.73	255
1914.....	188	133,000	20,700	44	903,000	.....	14.73	295
1913.....	157	124,152	20,500	49	1,003,000	.....	12.38	248
<b>Territory of Hawaii:</b>								
1919.....	178	600,312	119,700	40	4,744,000	239,900	12.65	253
1918.....	184	576,700	119,800	41	4,855,000	276,800	11.88	238
1917.....	190	644,663	123,900	42	5,220,000	245,100	12.35	247
1916.....	180	592,763	115,419	42	4,859,424	246,332	12.20	244
1915.....	195	646,000	113,200	46	5,185,000	239,800	12.46	249
1914.....	183	612,000	112,700	43	4,900,000	.....	12.49	250
1913.....	169	546,524	114,600	39	4,476,000	.....	12.21	244

TABLE 199.—Sugar: Wholesale price per pound, on New York market, 1913-1919.

Date.	Raw, centrifugal, 96° polarization.			Refined.								
				Cut loaf.			Granulated, fine or standard.			Soft sugar No. 1.		
	Low.	High.	Average.	Low.	High.	Average.	Low.	High.	Average.	Low.	High.	Average.
<b>1913.</b>												
January-June.....	Cts. 3.25	Cts. 3.73	.....	Cts. 5.05	Cts. 5.70	.....	Cts. 4.25	Cts. 4.95	.....	Cts. 4.65	Cts. 4.00	.....
July-December.....	3.12	3.80	.....	5.05	5.60	.....	4.15	4.85	.....	4.05	4.55	.....
<b>1914.</b>												
January-June.....	2.92	3.48	.....	5.05	5.25	.....	3.85	4.35	.....	3.60	4.10	.....
July-December.....	3.26	6.52	.....	5.25	8.40	.....	3.85	7.55	.....	4.10	7.30	.....
<b>1915.</b>												
January-June.....	3.95	5.02	.....	5.85	7.00	.....	4.95	6.15	.....	4.70	5.85	.....
July-December.....	3.50	5.20	.....	5.80	7.05	.....	4.90	6.20	.....	4.65	5.90	.....
<b>1916.</b>												
January-June.....	4.33	6.52	.....	6.65	8.80	.....	5.75	7.70	.....	5.50	7.50	.....
July-December.....	4.89	6.65	.....	7.40	8.80	.....	6.25	7.70	.....	6.10	7.50	.....
<b>1917.</b>												
January-June.....	4.64	6.52	.....	7.90	9.00	.....	6.75	7.55	.....	6.60	7.35	.....
July-December.....	5.92	7.77	.....	9.00	9.90	.....	7.50	8.45	.....	7.35	8.25	.....
<b>1918.</b>												
January-June.....	6.00	6.00	6.05	8.95	9.65	8.97	7.45	8.20	7.50	7.30	8.00	7.32
July-December.....	6.00	7.28	6.81	9.00	10.50	9.95	7.50	9.05	8.41	7.35	8.85	8.30

## SUGAR—Continued.

TABLE 199.—Sugar: Wholesale price per pound, on New York market, 1913-1919—Continued.

Date.	Raw, centrifugal, 96° polarization.			Refined.								
				Cut loaf.			Granulated, fine or standard.			Soft sugar No. 1.		
	Low.	High.	Average.	Low.	High.	Average.	Low.	High.	Average.	Low.	High.	Average.
1919.	<i>Cts.</i>	<i>Cts.</i>	<i>Cts.</i>	<i>Cts.</i>	<i>Cts.</i>	<i>Cts.</i>	<i>Cts.</i>	<i>Cts.</i>	<i>Cts.</i>	<i>Cts.</i>	<i>Cts.</i>	<i>Cts.</i>
January.....	7.28	7.28	7.28	10.50	10.50	10.50	9.00	9.05	9.025	8.85	8.85	8.85
February.....	7.28	7.28	7.28	10.50	10.50	10.50	9.00	9.05	9.025	8.85	8.85	8.85
March.....	7.28	7.28	7.28	10.50	10.50	10.50	9.00	9.05	9.025	8.85	8.85	8.85
April.....	7.28	7.28	7.28	10.50	10.50	10.50	9.00	9.05	9.025	8.85	8.85	8.85
May.....	7.28	7.28	7.28	10.50	10.50	10.50	9.00	9.05	9.025	8.85	8.85	8.85
June.....	7.28	7.28	7.28	10.50	10.50	10.50	9.00	9.05	9.025	8.85	8.85	8.85
January-June.	7.28	7.28	7.28	10.50	10.50	10.50	9.00	9.05	9.025	8.85	8.85	8.85
July.....	7.28	7.28	7.28	10.50	10.50	10.50	9.00	9.05	9.025	8.85	8.85	8.85
August.....	7.28	7.28	7.28	10.50	10.50	10.50	9.00	9.05	9.025	8.85	8.85	8.85
September.....	7.28	7.28	7.28	10.50	10.50	10.50	9.00	9.05	9.025	8.85	8.85	8.85
October.....	7.28	7.28	7.28	10.50	10.50	10.50	9.00	9.05	9.025	8.85	8.85	8.85
November.....	7.28	7.28	7.28	10.50	10.50	10.50	9.00	9.05	9.025	8.85	8.85	8.85
December.....	7.28	13.04	9.27	10.50	10.50	10.50	9.00	9.05	9.02	8.85	8.85	8.85
July-December	7.28	13.04	7.61	10.50	10.50	10.50	9.00	9.05	9.025	8.85	8.85	8.85

TABLE 200.—Sugar: International trade, calendar years 1909-1913, 1917, 1918.

[The following kinds and grades have been included under the head of sugar: Brown, white candied, caramel, chanaca (Peru), crystal cube, maple, muscovado, panels. The following have been excluded: "Candy" (meaning confectionery), confectionery, glucose, grape sugar, jaggery, molasses, and sirups. See "General note," Table 101.]

## EXPORTS.

[000 omitted.]

Country.	Average 1909-1913.	1917	1918	Country.	Average 1909-1913.	1917	1918
<i>From—</i>	<i>Pounds.</i>	<i>Pounds.</i>	<i>Pounds.</i>	<i>From—</i>	<i>Pounds.</i>	<i>Pounds.</i>	<i>Pounds.</i>
Argentina.....	144	70	21	Germany.....	1,746,322	.....	.....
Austria-Hungary.....	1,697,659	.....	.....	Guadeloupe.....	75,270	.....	.....
Barbadoes.....	51,657	.....	.....	Martinique.....	85,110	.....	.....
Belgium.....	308,952	.....	.....	Mauritius.....	452,510	.....	.....
Brazil.....	76,568	289,926	254,927	Netherlands.....	400,980	.....	.....
British Guiana.....	212,393	.....	.....	Peru.....	293,472	465,407	.....
British India.....	53,222	36,350	71,221	Philippine Islands..	358,865	453,946	602,425
China.....	29,867	30,871	26,905	Reunion.....	83,316	.....	.....
Cuba.....	4,019,798	6,441,717	7,293,915	Russia.....	587,028	.....	.....
Dominican Republic	184,703	289,929	264,624	Trinidad and Tobago	87,510	.....	.....
Dutch East Indies..	2,825,111	2,610,928	.....	United Kingdom....	65,207	2,470	1,804
Egypt.....	16,171	57,296	37,659	Other countries.....	660,878	.....	.....
Fiji.....	157,633	.....	.....	Total.....	14,944,141	.....	.....
France.....	413,795	188,727	136,672				

## IMPORTS.

Into—	Pounds.	Pounds.	Pounds.	Into—	Pounds.	Pounds.	Pounds.
Argentina.....	103,380	353,127	73,371	Netherlands.....	165,443	.....	.....
Australia.....	152,465	35,408	.....	New Zealand.....	125,924	148,332	111,367
British India.....	1,431,980	928,759	1,190,562	Norway.....	104,651	124,531	.....
British South Africa.	60,517	28,337	45,091	Persia.....	218,703	.....	.....
Canada.....	595,785	794,118	657,926	Portugal.....	79,262	.....	.....
Chile.....	169,931	199,106	.....	Singapore.....	163,220	.....	.....
China.....	687,243	826,277	1,165,173	Switzerland.....	236,403	235,560	160,649
Denmark.....	43,627	3,577	649	United Kingdom....	3,707,211	2,413,410	2,016,755
Egypt.....	86,041	24,076	40,704	United States <sup>1</sup> .....	4,245,034	4,944,089	5,170,976
Finland.....	100,153	.....	.....	Other countries.....	1,027,604	.....	.....
France.....	372,395	1,156,815	375,505	Total.....	14,249,356	.....	.....
Italy.....	18,499	123,964	81,638				
Japan.....	353,885	175,482	496,720				

<sup>1</sup> Not including receipts from Hawaii, amounting to an average for five years 1909-1913 of 1,089,659,793 in 1917 to 1,253,562,475, and in 1918, 1,009,749,843 pounds; and from Porto Rico, to an average for the five years 1909-1913 of 642,628,376; in 1917 to 642,439,175, and in 1918 to 801,329,419 pounds.



SUGAR—Continued.

TABLE 201.—Sugar production of undermentioned countries, campaigns of 1909-10 to 1918-19.

BEET SUGAR (RAW).

Country.	Average 1909-10, 1913-14.	1917-18	1918-19	Country.	Average 1909-10, 1913-14.	1917-18	1918-19
NORTH AMERICA.				EUROPE—contd.			
United States.....	Short tons. 609,620	Short tons. 765,207	Short tons. 760,950	Roumania.....	Short tons. 39,230		
Canada.....	11,457	11,688		Russia.....	1,828,012	1,133,804	
Total.....	621,077	776,695		Serbia.....	10,528		
EUROPE.				Spain.....	115,727	154,319	64,936
Austria-Hungary....	1,652,339			Sweden.....	153,581		
Belgium.....	276,075	142,497	80,949	Switzerland.....	4,390	9,921	12,125
Bulgaria.....	7,688			Total.....	7,858,785		
Denmark.....	127,602	148,700	155,755	OCEANIA.			
France.....	759,426	220,752	121,374	Australia.....	719	1,904	
Germany.....	2,429,141	1,530,913	1,317,628	Grand total...	8,480,551		
Italy.....	208,675						
Netherlands.....	246,341	214,891	181,986				

CANE SUGAR.

NORTH AMERICA.				SOUTH AMERICA— continued.			
United States:				Peru.....	210,608	276,575	
Louisiana.....	301,173	243,000	280,900	Total.....	562,873		
Texas.....	9,664	2,240	1,125	EUROPE.			
Hawaii.....	567,495	576,700	600,312	Spain.....	17,059	6,297	7,295
Porto Rico.....	363,474			ASIA.			
Virgin Islands.....	9,212			British India.....	2,614,396	3,616,480	2,617,440
Central America:				Formosa.....	192,299	518,089	288,000
British Honduras..	575			Japan.....	75,718		
Costa Rica.....	2,922	5,100	4,225	Java.....	1,513,736	1,919,442	1,960,118
Guatemala.....	8,284	20,550	17,500	Philippine Islands..	170,447	215,343	
Nicaragua.....	5,000	12,000	12,000	Total.....	4,566,596		
Salvador.....	13,616			AFRICA.			
Mexico.....	163,030			Egypt.....	67,128	50,774	48,768
West Indies:				Mauritius.....	233,671	248,531	278,628
British—				Natal.....	88,165	119,000	164,080
Antigua.....	12,919	13,234	14,679	Portuguese East Af- rica.....	27,800		
Barbados.....	27,788	68,120	84,000	Reunion.....	41,658		
Jamaica.....	23,856	35,840		Total.....	458,422		
Montserrat.....	222			OCEANIA.			
St. Christopher..	13,252			Australia.....	216,331	366,900	212,775
St. Lucia.....	5,436			Fiji.....	84,629		
St. Vincent.....	349	632		Total.....	300,960		
Trinidad and Tobago.....	51,275	79,398	50,687	Total cane su- gar.....	9,970,830		
Cuba.....	2,295,353	3,859,613	4,448,389	Total beet and cane sugar..	18,451,381		
Dominican Re- public.....	106,539	172,800	186,682				
French—							
Guadeloupe.....	40,917	30,864	25,142				
Martinique.....	142,567						
Total.....	4,064,920						
SOUTH AMERICA.							
Argentina.....	193,853	138,780					
Brazil.....	138,284	302,627	440,920				
Guiana:							
British.....	106,194	121,163	120,467				
Dutch.....	12,571	12,357					
Paraguay.....	1,363	808	619				

<sup>1</sup> Exports.

## SUGAR—Continued.

TABLE 202.—Sugar: Total production of countries mentioned in Table 201, 1895-96 to 1918-19.

Year.	Production.			Year.	Production.		
	Cane. <sup>1</sup>	Beet.	Total.		Cane. <sup>1</sup>	Beet.	Total.
	<i>Short tons.</i>	<i>Short tons.</i>	<i>Short tons.</i>		<i>Short tons.</i>	<i>Short tons.</i>	<i>Short tons.</i>
1895-96.....	3,259,000	4,832,000	8,091,000	1907-8.....	7,926,000	7,390,000	15,316,000
1896-97.....	3,171,000	5,549,000	8,720,000	1908-9.....	8,654,000	7,350,000	16,004,000
1897-98.....	3,206,000	5,457,000	8,663,000	1909-10.....	9,423,000	6,991,000	16,414,000
1898-99.....	3,355,000	5,616,000	8,971,000	1910-11.....	9,540,000	9,042,000	18,582,000
1899-1900.....	3,389,000	6,262,000	9,651,000	1911-12.....	10,275,000	7,072,000	17,347,000
1900-1901.....	4,084,000	6,795,000	10,879,000	1912-13.....	10,908,000	9,509,769	20,518,000
1901-2.....	6,818,000	7,743,000	14,561,000	1913-14.....	<sup>2</sup> 11,270,200	9,433,783	20,703,983
1902-3.....	6,782,000	6,454,000	13,236,000	1914-15.....	<sup>3</sup> 11,316,952	8,756,831	20,073,783
1903-4.....	6,909,000	6,835,000	13,744,000	1915-16.....	<sup>4</sup> 11,885,446	6,810,105	<sup>4</sup> 18,695,551
1904-5.....	7,662,000	5,525,000	13,187,000	1916-17.....	<sup>4</sup> 12,306,843	<sup>4</sup> 3,976,008	<sup>4</sup> 16,282,851
1905-6.....	7,551,000	8,090,000	15,641,000	1917-18.....	<sup>4</sup> 13,033,266	<sup>4</sup> 4,088,014	<sup>4</sup> 17,121,280
1906-7.....	8,365,000	7,587,000	15,952,000	1918-19.....	<sup>4</sup> 11,864,751	<sup>4</sup> 2,710,357	<sup>4</sup> 14,575,108

<sup>1</sup> Prior to 1901-2 these figures include exports instead of production for British India.<sup>2</sup> Excluding Costa Rica, Guatemala, and Salvador.<sup>3</sup> Excluding Salvador and St. Lucia.<sup>4</sup> Includes only countries for which reports were given in Table 201.

TABLE 203.—Beet and beet sugar production of undermentioned countries.

Country and year.	Factories in operation.	Sugar made, raw.	Beets used for sugar.			Average extraction of sugar.	
			Area harvested.	Average yield per acre.	Quantity worked.	Per centage of weight of beets used.	Per short ton of beets used.
Austria-Hungary:	<i>Number.</i>	<i>Short tons.</i>	<i>Acres.</i>	<i>Short tons.</i>	<i>Short tons.</i>	<i>Per cent.</i>	<i>Pounds.</i>
1910-11.....	214	1,549,102	918,201	11.95	11,038,503	17.5	281
1911-12.....	210	1,180,605	968,771	8.18	8,623,578	16.6	274
1912-13.....	218	2,093,439	1,088,088	13.00	13,911,305	14.8	301
Belgium:			<i>Area cultivated.</i>		<i>Produced.</i>	<i>P. c. of wt. of beets produced.</i>	<i>Per ton of beets produced.</i>
1910-11.....	92	299,035	148,858	13.41	1,996,977	14.97	299
1911-12.....	89	258,780	145,119	11.45	1,660,872	15.58	312
1912-13.....	88	309,308	152,913	12.47	1,907,358	16.22	324
1913-14.....	84	249,395	129,527	11.85	1,534,311	16.25	325
Denmark:							
1910-11.....	8	110,792			817,381	13.56	271
1911-12.....	8	128,032			809,616	15.81	316
1912-13.....	9	148,447	79,986	14.49	1,159,369	12.80	256
1913-14.....	9	179,002			1,025,140	17.46	349
1914-15.....	9	167,803	79,000		910,000		
1915-16.....	9	143,475	77,787		811,351		
1916-17.....	9	123,623	76,020		972,965		
France:		<i>Refined.</i>	<i>Area harvested.</i>		<i>Worked.</i>	<i>P. c. of wt. of beets used.</i>	<i>Per ton of beets used.</i>
1910-11.....	239	717,033	549,969	10.76	6,426,226	11.80	236
1911-12.....	220	512,986	555,575	8.09	4,669,083	11.41	228
1912-13.....	213	967,440	566,539	12.99	7,960,926	13.15	263
1913-14.....	206	790,790	534,230	12.24	6,539,725	12.09	242
1914-15.....	69	333,953	242,781	11.92	2,892,878	11.54	231
1915-16.....	64	149,801	146,305	8.65	1,265,518	11.84	237
Germany: <sup>1</sup>		<i>Raw.</i>					
1910-11.....	354	2,770,001	1,180,913	14.72	17,360,003	15.96	319
1911-12.....	342	1,551,797	1,247,213	8.03	9,987,473	15.54	311
1912-13.....	342	2,901,564	1,353,181	13.56	18,344,738	15.82	316
1913-14.....	341	2,885,572	1,316,655	14.19	18,672,939	15.45	309

<sup>1</sup> The production of sugar in Germany, including refined from imported raw sugar, was 2,983,085 short tons in 1912-13 and 2,993,704 in 1913-14.

SUGAR—Continued.

TABLE 203.—Beet and beet sugar production of undermentioned countries—Continued.

Country and year.	Factories in operation.	Sugar made, raw (short tons).	Beets used for sugar.			Average extraction of sugar.	
			Area harvested (acres).	Average yield per acre.	Quantity worked.	Per cent- age of weight of beets used.	Per short ton of beets used.
<b>Italy:</b>	<i>Number.</i>	<i>Refined.</i>	<i>Area cultivated.</i>	<i>Short tons.</i>	<i>Short tons.</i>		<i>Pounds.</i>
1910-11.....	35	190,901	124,044	14.92	1,698,551	11.24	225
1911-12.....	37	174,894	131,260	13.30	1,621,760	10.78	216
1912-13.....	37	218,628	133,434	14.40	1,879,328	11.63	233
1913-14.....	37	336,823	152,700	19.70	2,994,816	11.25	225
1914-15.....	30	165,583	100,570	.....	1,422,235	.....	.....
1915-16.....	36	165,781	122,809	.....	1,582,542	.....	.....
<b>Netherlands:</b>							
1910-11.....	27	219,947	138,554	12.94	1,678,803	13.10	262
1911-12.....	27	265,401	137,388	16.06	1,896,187	14.00	280
1912-13.....	27	315,775	160,180	14.99	2,228,851	14.17	283
1913-14.....	27	231,073	149,001	12.27	1,705,878	13.55	271
1914-15.....	27	316,346	156,251	14.06	2,193,577	14.42	288
1915-16 (prelim.)....	23	240,828	139,644	13.52	1,755,964	13.71	274
<b>Russia:</b>		<i>Raw.</i>					
1910-11.....	276	2,074,410	1,631,188	8.9	14,437,305	14.61	292
1911-12.....	281	2,036,990	1,923,539	7.8	14,754,312	13.84	277
1912-13.....	287	1,361,842	1,847,313	6.4	11,538,078	11.73	235
1913-14.....	293	1,680,893	1,756,160	7.7	13,436,058	12.51	250
1914-15.....	265	1,958,975	1,941,122	7.4	13,979,662	14.01	280
1915-16.....	235	1,697,356	1,748,466	7.0	12,324,612	13.77	275
<b>Spain:</b>							
1910-11.....	33	68,743	( <sup>1</sup> )		532,882	12.90	258
1911-12.....	32	102,859	90,787		872,834	11.78	236
1912-13.....	33	171,839	105,213		1,302,871	11.33	264
1913-14.....	31	186,680	146,745	( <sup>1</sup> )	1,478,114	12.62	252
1914-15.....	( <sup>2</sup> )	112,231	78,642		813,790	12.08	.....
1915-16.....	27	117,334	99,114		921,013	10.65	.....
<b>Sweden:</b>							
1910-11.....	24	191,713	86,816	13.56	1,218,166	15.53	315
1911-12.....	24	140,409	71,790	14.83	908,372	15.27	309
1912-13.....	24	145,462	66,900	13.95	922,083	15.59	316
<b>United States:</b>		<i>Refined.</i>	<i>Area harvested.</i>				
1910-11.....	61	510,172	398,029	10.17	4,047,292	12.61	252
1911-12.....	66	599,500	473,877	10.68	5,062,333	11.84	237
1912-13.....	73	692,556	555,300	9.41	5,224,377	13.26	265
1913-14.....	71	733,401	580,006	9.76	5,659,462	12.96	259
1914-15.....	60	722,054	483,400	10.9	5,288,500	13.65	273
1915-16.....	67	874,220	611,301	10.1	6,150,293	14.21	267
1916-17.....	74	820,657	665,308	8.90	5,919,673	13.86	277
1917-18.....	91	765,207	664,797	8.46	5,625,545	13.60	272
1918-19.....	89	760,950	594,010	9.39	5,577,506	13.64	273
1919-20 <sup>2</sup> .....	90	763,848	696,503	9.18	6,396,860	11.94	239

<sup>1</sup> No data.

<sup>2</sup> Preliminary.

## SUGAR—Continued.

TABLE 204.—Cane and cane-sugar production of undermentioned countries.

Country and year.	Factories in operation.	Sugar made.	Cane used for sugar.			Average extraction of sugar.
			Area harvested.	Average per acre.	Quantity worked.	Per ton of cane used.
<b>Argentina:</b>	<i>Number.</i>	<i>Short tons.</i>	<i>Acres cultivated.</i>	<i>Short tons.</i>	<i>Short tons.</i>	<i>Pounds.</i>
1910-11.....	(1)	163,701	178,060	(1)	(1)	(1)
1911-12.....	(1)	198,515	230,866	(1)	(1)	(1)
1912-13.....	39	162,313	232,830	(1)	2,338,594	139
1913-14.....	38	304,389	263,656	(1)	3,451,321	176
1914-15.....	37	370,324	269,833	(1)	4,027,067	184
<b>Australia:</b>			<i>Harvested.</i>		<i>Produced.</i>	
1910-11.....	53	253,131	100,237	22.36	2,240,849	226
1911-12.....	53	210,292	101,015	18.65	1,884,120	223
1912-13.....	50	144,776	84,279	15.09	1,271,358	228
<b>Cuba:</b>			<i>Cultivated.</i>			
1910-11.....	171	1,670,151	(2)	(2)	14,736,981	227
1911-12.....	172	2,142,420	(2)	(2)	20,679,593	207
1912-13.....	171	2,737,264	1,340,139	(2)	25,137,684	218
1913-14.....	170	2,891,281	1,334,070	(2)	25,644,949	226
1914-15.....	177	2,967,427			28,068,993	
1915-16.....		3,398,385			26,324,706	
1916-17.....		3,421,897			28,149,841	
<b>Hawaii:</b>			<i>Harvested.</i>			
1911-12.....	(1)	595,038	113,000	42.0	4,774,000	249
1912-13.....	(1)	546,524	114,600	39.0	4,476,000	244
1913-14.....	46	612,000	112,700	45.0	5,094,000	240
1914-15.....	45	646,000	113,200	46.0	5,185,000	249
1915-16.....	(1)	592,763	115,419	42.0	4,859,424	244
1916-17.....	(1)	644,663	123,900	42.0	5,220,000	247
1917-18.....	(1)	576,700	119,800	41.0	4,855,090	238
1918-19.....	(1)	600,312	119,700	40.0	4,744,000	253
<b>Japan:</b>			<i>Cultivated.</i>			
1910-11.....	13	72,454	49,166	18.49	892,662	162
1911-12.....	14	75,797	52,153	18.16	941,550	161
1912-13.....	17	68,867	51,293	17.15	879,624	157
1913-14.....	16	72,613	53,300	17.91	954,758	152
<b>Java (factory plantations):</b>			<i>Harvested.</i>			
1910-11.....	189	1,583,178	321,720	46.43	14,936,035	212
1911-12.....	193	1,424,657	336,021	40.71	13,679,962	208
1912-13.....	191	1,527,584	340,739	45.11	15,370,765	199
<b>Spain:</b>			<i>Cultivated.</i>			
1910-11.....	27	22,371	11,666	21.9	258,138	173
1911-12.....	23	17,831	9,983	16.5	167,092	213
1912-13.....	21	14,585	9,844	15.6	153,707	190
1913-14.....	22	8,131	4,581	17.4	79,719	204
1914-15.....	(1)	6,168	4,717	(1)	70,410	(1)
1915-16.....	16	4,700	2,950	16.59	48,937	194
1916-17.....	16	5,053	4,621		70,286	
<b>United States (Louisiana):</b>			<i>Harvested for sugar.</i>			
1911-12.....	188	352,874	310,000	19.0	5,887,292	120
1912-13.....	126	153,573	197,000	11.0	2,162,574	142
1913-14.....	153	292,698	248,000	17.0	4,214,000	139
1914-15.....	149	242,700	213,000	15.0	3,199,000	152
1915-16.....	136	137,500	183,000	11.0	2,018,000	135
1916-17.....	150	303,900	221,000	18.0	4,072,000	149
1917-18.....	140	243,600	244,000	15.6	3,813,000	128
1918-19.....	134	280,900	231,200	18.0	4,170,000	135
1919-20.....		115,590	176,500	10.0	1,765,000	131

<sup>1</sup> No data.<sup>2</sup> Preliminary.

SUGAR—Continued.

TABLE 205.—Sugar beets: Area and production in undermentioned countries, 1909–1918.  
[000 omitted.]

Country.	Area.				Production.			
	Average 1909–1913. <sup>1</sup>	1916	1917	1918	Average 1909–1913. <sup>1</sup>	1916	1917	1918
NORTH AMERICA.								
United States.....	Acres. 568	Acres. 665	Acres. 665	Acres. 792	Short tons. 5,555	Short tons. 6,228	Short tons. 5,980	Short tons. 7,303
Canada.....	18	15	14	18	174	71	118	180
Total.....	586	680	679	810	5,729	6,299	6,098	7,483
EUROPE.								
Austria <sup>2</sup> .....	642	(3)	(3)	(3)	8,202	(3)	(3)	(3)
Hungary <sup>2</sup> .....	432	(3)	(3)	(3)	5,275	(3)	(3)	(3)
Croatia-Slavonia <sup>2</sup> .....	10	(3)	(3)	(3)	73	(3)	(3)	(3)
Bosnia-Herzegovina <sup>2</sup> .....	3	(3)	(3)	(3)	12	(3)	(3)	(3)
Belgium.....	142	(3)	(3)	(3)	1,720	(3)	(3)	(3)
Bulgaria <sup>2</sup> .....	8	(3)	(3)	(3)	81	(3)	(3)	(3)
Denmark.....	80	78	76	89	1,025	811	973	1,041
England.....	4	(4)	(3)	(3)	(3)	(3)	(3)	(3)
France <sup>2</sup> .....	623	<sup>5</sup> 201	<sup>5</sup> 180	169	7,254	<sup>5</sup> 2,192	<sup>5</sup> 2,324	(3)
Germany <sup>2</sup> .....	1,335	<sup>6</sup> 1,018	<sup>6</sup> 992	<sup>6</sup> 993	18,509	<sup>6</sup> 11,175	<sup>6</sup> 11,009	<sup>6</sup> 10,895
Italy.....	143	123	120	106	2,465	1,486	1,237	1,250
Netherlands.....	154	157	115	92	2,117	2,115	1,826	1,317
Roumania <sup>2</sup> .....	34	30	(3)	7 18	316	(3)	(3)	7 54
Russia proper <sup>2</sup> .....	1,578	(3)	(3)	(3)	12,119	(3)	(3)	(3)
Poland <sup>2</sup> .....	170	(3)	(3)	(3)	1,399	(3)	(3)	(3)
North Caucasia (Kuban) <sup>2</sup> .....	8	(3)	(3)	(3)	84	(3)	(3)	(3)
Spain.....	126	134	146	163	2,130	830	923	742
Sweden.....	69	92	78	75	940	1,033	986	895
Switzerland.....	2	2	(3)	(3)	21	22	(3)	(3)
Total.....	5,563	.....	.....	.....	63,742	.....	.....	.....
Grand total.....	6,149	.....	.....	.....	69,471	.....	.....	.....

- <sup>1</sup> Five-year average, except where statistics were not available.
- <sup>2</sup> Old boundaries.
- <sup>3</sup> No official statistics.
- <sup>4</sup> Less than 500.
- <sup>5</sup> Exclusive of invaded area, in which 115,900 acres were under sugar in 1914.
- <sup>6</sup> Excludes Alsace-Lorraine.
- <sup>7</sup> Including Bessarabia but excluding Dobrudja.

MAPLE SUGAR AND SIRUP.

TABLE 206.—Maple sugar and sirup production, 1909, 1917, 1918, and 1919.

[Figures for 1909 are from the United States census; all others are based upon reports from field agents and correspondents of the Bureau of Crop Estimates.]

State and year.	Trees tapped.	Sugar made.	Sirup made.	Average per tree.	
				As sugar.	As sirup.
Maine:					
1919.....	Number. 304,000	Pounds. 63,232	Gallons. 41,496	Pounds. 1.3	Gallons. 0.16
1918.....	290,000	46,400	52,200	1.6	.20
1917.....	255,000	42,350	48,700	1.7	.21
1909.....	252,764	15,388	43,971	1.45	.18
New Hampshire:					
1919.....	870,000	445,440	118,320	1.6	.20
1918.....	870,000	556,800	147,900	2.0	.25
1917.....	800,000	537,600	142,800	2.1	.26
1909.....	792,147	558,811	111,500	1.83	.23
Vermont:					
1919.....	5,665,000	4,894,560	521,180	1.6	.20
1918.....	5,500,000	6,237,000	664,100	2.10	.26
1917.....	5,100,000	5,626,300	552,600	1.97	.25
1909.....	5,585,632	7,726,817	409,953	1.98	.25

## MAPLE SUGAR AND SIRUP—Continued.

TABLE 206.—Maple sugar and sirup production, 1909, 1917, 1918, and 1919—Contd.

State and year.	Trees tapped.	Sugar made.	Sirup made.	Average per tree.	
				As sugar.	As sirup.
	<i>Number.</i>	<i>Pounds.</i>	<i>Gallons.</i>	<i>Pounds.</i>	<i>Gallons.</i>
<b>Massachusetts:</b>					
1919.....	273,900	138,045	44,374	1.8	.23
1918.....	273,900	182,600	50,800	2.15	.27
1917.....	256,000	182,700	50,800	2.30	.23
1909.....	256,501	156,952	53,091	2.27	.28
<b>Connecticut:</b>					
1919.....	13,500	5,832	2,308	1.8	.22
1918.....	13,500	8,900	3,900	3.0	.38
1917.....	12,000	6,600	2,900	2.5	.31
1909.....	12,296	10,207	4,236	3.65	.46
<b>New York:</b>					
1919.....	6,062,000	3,161,000	1,401,000	2.37	.30
1918.....	6,236,000	3,732,000	1,755,000	2.85	.35
1917.....	5,724,000	2,255,000	1,485,000	2.47	.31
1909.....	4,948,784	3,160,300	993,242	2.24	.28
<b>Pennsylvania:</b>					
1919.....	1,244,000	686,800	318,800	2.60	.33
1918.....	1,220,000	993,000	440,000	3.7	.46
1917.....	1,130,000	988,800	370,800	3.5	.44
1909.....	1,298,005	1,188,049	391,242	3.33	.42
<b>Maryland:</b>					
1919.....	76,300	221,300	20,000	5.0	.62
1918.....	74,800	179,500	15,000	4.0	.50
1917.....	68,000	161,800	9,500	3.5	.44
1909.....	79,658	351,908	12,172	5.64	.70
<b>West Virginia:</b>					
1919.....	100,000	160,000	30,000	4.0	.50
1918.....	105,000	147,000	27,500	3.5	.44
1917.....	85,000	151,700	18,200	3.5	.44
1909.....	97,274	140,060	31,176	4.0	.50
<b>Ohio:</b>					
1919.....	2,378,000	199,750	807,330	2.8	.35
1918.....	2,660,000	558,600	1,093,900	3.5	.44
1917.....	2,418,000	536,800	1,051,300	3.7	.46
1909.....	3,170,828	257,592	1,323,431	3.42	.43
<b>Indiana:</b>					
1919.....	700,000	200,000	273,000	3.40	.43
1918.....	700,000	238,000	267,800	3.4	.42
1917.....	637,000	48,000	296,600	3.8	.48
1909.....	742,586	33,419	273,728	2.99	.37
<b>Michigan:</b>					
1919.....	874,000	230,800	211,500	2.20	.28
1918.....	930,000	364,600	279,900	2.80	.35
1917.....	641,400	229,000	175,900	2.55	.32
1909.....	986,737	293,301	269,093	2.48	.31
<b>Wisconsin:</b>					
1919.....	442,000	19,200	95,800	1.78	.22
1918.....	425,000	26,500	107,200	2.08	.26
1917.....	340,000	72,000	81,000	2.12	.26
1909.....	449,727	27,199	124,117	2.26	.28
<b>Total 13 States:</b>					
1919.....	19,002,700	10,425,959	3,885,108	2.18	.27
1918.....	19,298,200	13,270,900	4,905,200	2.72	.35
1917.....	17,466,400	10,838,650	4,286,100	2.58	.32
1909.....	18,672,939	13,920,003	4,040,952	2.48	.31

NOTE.—These 13 States produced, in 1909, 99 per cent of the maple-sugar crops of the United States and 98.4 per cent of the maple sirup.

TABLE 207.—Maple sugar and sirup: Farm price, 15th of month, 1913-1919.

Date.	Sugar (cents per pound).							Sirup (dollars per gallon).						
	1919	1918	1917	1916	1915	1914	1913	1919	1918	1917	1916	1915	1914	1913
Feb. 15.....	22.0	18.8	14.7	12.6	11.6	.....	12.2	1.86	1.58	1.22	1.08	1.06	.....	1.06
Mar. 15.....	25.3	20.5	14.7	13.4	12.5	12.4	12.6	1.99	1.76	1.30	1.11	1.10	1.10	1.06
Apr. 15.....	26.9	22.5	16.3	13.9	12.9	12.5	13.0	2.03	1.80	1.33	1.17	1.10	1.10	1.10
May 15.....	26.3	22.6	16.2	13.6	12.3	12.3	12.3	2.02	1.85	1.34	1.15	1.07	1.10	1.08
June 15.....	26.2	22.0	15.9	13.7	12.4	12.2	12.1	2.19	1.85	1.33	1.16	1.12	1.12	1.09

SORGHUM FOR SIRUP.

TABLE 208.—Sorghum for sirup: Acreage, production, and value, by States 1919, and totals 1917-1919.

State and year.	Acreage.	Average yield per acre.	Production of sirup.	Average farm price per gallon Dec. 1.	Farm value Dec. 1.
	<i>Acres.</i>	<i>Gallons.</i>	<i>Gallons.</i>	<i>Cents.</i>	<i>Dollars.</i>
Virginia.....	11,000	93	1,023,000	108	1,105,000
West Virginia.....	5,000	100	500,000	134	670,000
North Carolina.....	40,000	91	3,640,000	101	3,676,000
South Carolina.....	8,000	85	680,000	104	707,000
Georgia.....	16,000	92	1,472,000	102	1,501,000
Florida.....	600	130	78,000	111	87,000
Ohio.....	5,400	84	454,000	150	681,000
Indiana.....	11,300	82	927,000	147	1,363,000
Illinois.....	8,500	72	612,000	148	906,000
Wisconsin.....	3,000	75	225,000	176	396,000
Minnesota.....	3,000	128	384,000	145	557,000
Iowa.....	5,000	90	450,000	142	639,000
Missouri.....	19,500	83	1,618,000	128	2,071,000
Nebraska.....	2,000	75	150,000	129	194,000
Kansas.....	7,000	70	490,000	122	598,000
Kentucky.....	29,900	85	2,542,000	124	3,152,000
Tennessee.....	18,000	87	1,566,000	105	1,644,000
Alabama.....	100,000	91	9,100,000	95	8,645,000
Mississippi.....	60,000	85	5,100,000	95	4,845,000
Louisiana.....	600	110	66,000	106	70,000
Texas.....	8,300	68	564,000	102	575,000
Oklahoma.....	7,800	87	679,000	104	706,000
Arkansas.....	16,000	60	960,000	103	989,000
Utah.....	300	105	32,000	153	49,000
Total.....	386,200	86.3	33,312,000	107.5	35,826,000
1918.....	374,800	79.1	29,643,000	96.3	28,532,000
1917.....	415,200	90.3	37,472,000	69.5	26,055,000

TEA.

TABLE 209.—Tea: International trade, calendar years 1909-1913, 1917, and 1918.

["Tea" includes tea leaves only and excludes dust, sweepings, and yerba maté. See "General note," Table 101.]

EXPORTS.

[000 omitted.]

Country.	Average 1909-1913.	1917 (preliminary).	1918 (preliminary).	Country.	Average 1909-1913.	1917 (preliminary).	1918 (preliminary).
<i>From—</i>	<i>Pounds.</i>	<i>Pounds.</i>	<i>Pounds.</i>	<i>From—</i>	<i>Pounds.</i>	<i>Pounds.</i>	<i>Pounds.</i>
British India.....	267,887	299,180	378,075	Japan.....	35,823	61,765	46,825
Ceylon.....	189,016	195,232	180,818	Singapore.....	2,575	.....	.....
China.....	197,997	149,342	53,479	Other countries.....	6,991	.....	.....
Dutch East Indies.....	46,675	76,710	.....	Total.....	770,604	.....	.....
Formosa.....	23,640	26,169	.....				

IMPORTS.

<i>Into—</i>				<i>Into—</i>			
Argentina.....	3,800	2,381	4,037	Germany.....	8,964	.....	.....
Australia.....	35,442	37,390	.....	Netherlands.....	11,383	.....	.....
Austria-Hungary.....	3,424	.....	.....	New Zealand.....	7,542	9,478	9,692
British India.....	8,002	13,247	17,199	Persia.....	9,446	.....	.....
British South Africa.....	5,544	8,930	10,510	Russia.....	157,704	.....	.....
Canada.....	37,927	52,145	29,964	Singapore.....	6,009	.....	.....
Chile.....	3,505	3,659	.....	United Kingdom.....	293,045	277,436	310,687
China.....	18,890	25,259	6,338	United States.....	98,897	126,795	134,418
Dutch East Indies.....	6,742	7,976	.....	Other countries.....	34,294	.....	.....
France.....	2,806	5,196	3,203	Total.....	756,751	.....	.....
French Indo-China.....	3,295	.....	.....				

## TEA—Continued.

TABLE 210.—Tea: Wholesale price per pound on New York market, 1913–1919.

Date.	Foochow, fair to fine.			Formosa, fine to choice.			Japan, pan-fired.			India, orange pekoe.			Ceylon, orange pekoe.		
	Low.	High.	Average.	Low.	High.	Average.	Low.	High.	Average.	Low.	High.	Average.	Low.	High.	Average.
1913.															
January-June.....	Cts. 12	Cts. 22	Cts. ....	Cts. 24	Cts. 39	Cts. ....	Cts. 13½	Cts. 35	Cts. ....	Cts. 18½	Cts. 24	Cts. ....	Cts. 18½	Cts. 24	Cts. ....
July-December.....	12	22	.....	24	39	.....	13½	28	.....	18½	21	.....	18½	24	.....
1914.															
January-June.....	12	22	.....	24	39	.....	12½	30	.....	18½	21	.....	18½	24	.....
July-December.....	12½	22	.....	23	39	.....	12½	38	.....	18½	27	.....	18½	26	.....
1915.															
January-June.....	15	22	.....	23	39	.....	18	35	.....	.....	.....	.....	21	30	.....
July-December.....	17	22	.....	23	39	.....	18	40	.....	24	32	.....	24	31	.....
1916.															
January-June.....	17½	21	.....	23	39	.....	16	35½	.....	24	30	.....	24	30	.....
July-December.....	17½	21	.....	23	39	.....	16	35	.....	28	30	.....	28	30	.....
1917.															
January-June.....	17½	26	.....	23	60	.....	16	40	.....	28	47	.....	28	53	.....
July-December.....	22½	27	.....	40	60	.....	21	40	.....	39	45	.....	40	50	.....
1918.															
January-June.....	26½	27	26.8	35	60	49.8	24	40	32.1	35	50	42.8	36	50	41.6
July-December.....	26½	30½	29.8	35	60	47.8	25	45	35.6	35	50	42.5	36	45	40.5
1919.															
January.....	29	30½	29.8	36	60	48.0	28	45	31.5	32	50	38.5	35	45	40.1
February.....	29	30½	29.8	36	60	48.0	26	45	36.4	30	35	33.4	30	45	39.3
March.....	29	30½	29.8	33	60	47.3	24	45	35.0	30	35	32.5	30	40	35.0
April.....	29	30½	29.8	33	60	46.0	24	45	34.0	30	35	32.5	30	40	35.0
May.....	29	30½	29.8	33	62	46.5	24	48	34.8	30	35	32.5	30	40	36.0
June.....	29	30½	29.8	34	62	48.0	24	50	36.1	30	35	32.5	33	45	39.1
January-June....	29	30½	29.8	33	62	47.3	24	50	34.6	30	50	33.6	30	45	37.4
July.....	29	30½	29.8	34	62	48.0	25	50	37.5	30	35	32.8	38	48	42.9
August.....	29	30½	29.8	34	62	48.0	25	50	37.5	32	35	33.5	42	50	47.3
September.....	29	30½	29.8	34	62	48.0	25	60	41.6	32	35	33.5	44	50	47.0
October.....	(1)	(1)	(1)	34	62	48.0	25	60	42.5	32	35	33.6	44	50	47.0
November.....	(1)	(1)	(1)	34	62	48.7	25	60	42.5	32	40	36.7	44	50	47.0
December.....	(1)	(1)	(1)	34	62	29.3	25	60	42.5	36	45	42.2	44	50	47.0
July-December..	29	30½	29.8	23	62	48.0	25	60	40.7	30	45	35.4	38	50	46.4

! No quotations.



COFFEE.

TABLE 211.—Coffee: International trade, calendar years 1909–1913, 1917, and 1918.

[The item of coffee comprises unhulled and hulled, ground or otherwise prepared, but imitation or "surrogate" coffee and chicory are excluded. See "General note," Table 101.]

EXPORTS.

[000 omitted.]

Country.	Average, 1909–1913.	1917 (prelim.)	1918 (prelim.)	Country.	Average, 1909–1913.	1917 (prelim.)	1918 (prelim.)
<i>From—</i>	<i>Pounds.</i>	<i>Pounds.</i>	<i>Pounds.</i>	<i>From—</i>	<i>Pounds.</i>	<i>Pounds.</i>	<i>Pounds.</i>
Belgium.....	33,626			Netherlands.....	189,288		
Brazil.....	1,672,282	1,402,832	983,208	Nicaragua.....	19,033		
British India.....	27,780	27,632	14,868	Salvador.....	62,830	79,923	
Colombia.....	104,398	138,518	151,935	Singapore.....	4,700		
Costa Rica.....	27,515	27,048		United States <sup>1</sup> .....	44,251	48,592	44,727
Dutch East Indies..	54,148	36,169		Venezuela.....	111,326	97,236	88,155
Guatemala.....	85,951			Other countries.....	52,022		
Haiti.....	61,943						
Jamaica.....	8,263			Total.....	2,608,347		
Mexico.....	48,991						

IMPORTS.

<i>Into—</i>				<i>Into—</i>			
Argentina.....	28,125	37,438	48,572	Norway.....	29,309	32,973	
Austria-Hungary....	128,304			Russia.....	26,073		
Belgium.....	111,738			Singapore.....	6,000		
British South Africa.	26,445	30,169	47,845	Spain.....	29,316	40,229	36,097
Cuba.....	24,906	27,642	26,050	Sweden.....	74,486	18,893	
Denmark.....	33,102	41,874	6,155	Switzerland.....	25,029	21,193	22,534
Egypt.....	15,654	15,843	15,693	United Kingdom....	28,581	45,299	47,934
Finland.....	28,624			United States.....	907,899	1,286,524	1,052,202
France.....	245,752	360,873	299,052	Other countries.....	103,377		
Germany.....	399,965						
Italy.....	58,278	98,830	113,848	Total.....	2,614,596		
Netherlands.....	283,633						

<sup>1</sup> Chiefly from Porto Rico.

TABLE 212.—Coffee: Wholesale price per pound on the New York and New Orleans markets, 1913-1919.

Date.	New York.																		New Orleans.					
	Rio No. 7.			Santa No. 7.			Mocha.			Padang.			Cucuta, washed			Mexican, cordova.			Rio No. 7.			Santos No. 7.		
	Low.	High.	Average.	Low.	High.	Average.	Low.	High.	Average.	Low.	High.	Average.	Low.	High.	Average.	Low.	High.	Average.	Low.	High.	Average.	Low.	High.	Average.
1913.	Cts.	Cts.	Cts.	Cts.	Cts.	Cts.	Cts.	Cts.	Cts.	Cts.	Cts.	Cts.	Cts.	Cts.	Cts.	Cts.	Cts.	Cts.	Cts.	Cts.	Cts.	Cts.	Cts.	Cts.
January-June	9½	14	.....	10½	15½	.....	18	21	.....	19	22	.....	12	17½	.....	15	18	.....	9½	14	.....	11½	15	.....
July-December	8½	11½	.....	10½	13½	.....	18	20	.....	21	23	.....	11½	17½	.....	15	16½	.....	9	11½	.....	10½	12½	.....
1914.																								
January-June	8½	9½	.....	10½	11½	.....	17½	21	.....	21	23	.....	14½	18	.....	15½	16½	.....	8½	9½	.....	10½	11½	.....
July-December	6½	9	.....	8½	12½	.....	19½	30	.....	21	24	.....	11	18½	.....	12	17½	.....	6½	10½	.....	8½	13½	.....
1915.																								
January-June	7	8½	.....	8½	9½	.....	21½	30	.....	21	23½	.....	11½	15½	.....	12	14½	.....	7	8½	.....	8½	9½	.....
July-December	6½	7½	.....	7½	9	.....	23	30	.....	21	23	.....	11	15½	.....	10½	13½	.....	6½	8	.....	7½	9	.....
1916.																								
January-June	7½	9½	.....	7½	9½	.....	19	27	.....	22½	26½	.....	11½	16½	.....	11½	14½	.....	7½	10½	.....	8½	10	.....
July-December	9	10½	.....	9½	11	.....	18½	20½	.....	25	26½	.....	12	14½	.....	11½	13½	.....	8½	10½	.....	9½	10½	.....
1917.																								
January-June	9½	10½	.....	9½	10½	.....	18½	22	.....	24	26	.....	11½	14½	.....	11	14½	.....	9½	10½	.....	9½	10½	.....
July-December	7½	9½	.....	8½	9½	.....	19	22½	.....	24	26	.....	10½	14	.....	10½	13	.....	7½	9½	.....	9	10½	.....
1918.																								
January-June	8	9½	8.7	9½	10½	9.5	21½	26½	25.6	25	26	25.5	11	13½	12.7	10½	13½	12.6	8½	9½	9.1	9½	11½	10.8
July-December	8½	17½	10.9	10½	21	13.6	26½	37	32.1	25	29	26.1	12½	25	15.6	12½	23½	15.1	9	11½	10.2	10½	14½	12.6
1919.																								
January	14½	17½	15.6	19½	21	20.2	32	34	32.0	25½	29	27.4	20	25	23.2	20½	23½	22.3	15½	17	15.9	20½	21	20.7
February	15	15½	15.3	19½	20	19.9	28	34	30.4	25½	29	27.2	20	22½	21.5	20½	22½	21.5	15½	16½	15.2	20½	20½	20.5
March	15½	16½	15.9	19½	20	20.0	28	32	30.0	25½	29	27.2	21	22½	21.8	21½	22½	22.0	15½	19½	16.2	19½	20½	20.1
April	16½	18½	16.8	20	20½	20.0	28	32	30.0	25½	29	27.2	21	24½	22.4	21½	22½	22.0	16½	18½	16.7	19½	21½	20.4
May	18½	20	19.2	20½	23½	21.8	28	32	30.0	25½	29½	27.9	22½	27½	25.8	21½	27	24.1	19½	21½	20.1	21½	23½	22.3
June	20	25½	21.3	23½	26½	24.3	28	32	30.0	25½	29	26.3	26½	29½	25.7	26	28	26.9	20½	25½	22.6	23½	28½	25.6
January-June	14½	25½	17.4	19½	26½	21.0	28	34	30.4	25½	29½	27.2	20	29½	23.4	20½	28	23.1	15½	25½	17.8	19½	28½	21.6
July	22	23½	22.5	(1)	(1)	(1)	39	40	39.5	29	30	29.7	28	29½	28.8	27½	29½	28.8	22½	23½	23.0	27	28½	27.6
August	19½	23½	21.7	(1)	(1)	(1)	39	40	39.5	30	30	30.0	28	29½	28.9	29	31	30.0	19½	23	21.8	25½	28	27.4
September	15	19½	16.9	(1)	(1)	(1)	39	40	39.1	29	30	29.8	26½	29	27.5	27½	31	28.8	15½	25½	17.5	19	25½	24.0
October	15	17½	16.2	(1)	(1)	(1)	29	40	32.1	30	31	30.4	24	27½	24.8	25½	28½	26.0	15½	17½	16.3	22½	23½	23.1
November	15½	18½	16.8	(1)	(1)	(1)	32½	37½	34.8	30½	31	30.8	26½	28	27.3	27	29½	28.3	15½	18	17.0	22½	24½	23.7
December	15	15½	15	(1)	(1)	(1)	34	37½	35.8	33½	35½	34.1	25½	26½	26.0	23½	29	25.7	15½	18½	16.1	22½	23½	22.7
July-December	15	23½	18.2	(1)	(1)	(1)	29	40	36.8	29	35½	30.8	24	29½	27.2	23½	31	27.9	15½	25½	18.6	19	28½	24.8

1 No quotations.

OIL CAKE AND OIL-CAKE MEAL.

TABLE 213.—Oil cake and oil-cake meal: International trade, calendar years 1909-1913, 1917, and 1918.

[The class called here "oil cake and oil-cake meal" includes the edible cake and meal remaining after making oil from such products as cotton seed, flaxseed, peanuts, corn, etc. See "General note," Table 101.]

EXPORTS.

[000 omitted.]

Country.	Average, 1909-1913.	1917 (prelim.)	1918 (prelim.)	Country.	Average, 1909-1913.	1917 (prelim.)	1918 (prelim.)
<i>From—</i>	<i>Pounds.</i>	<i>Pounds.</i>	<i>Pounds.</i>	<i>From—</i>	<i>Pounds.</i>	<i>Pounds.</i>	<i>Pounds.</i>
Argentina.....	42,587	37,849	19,258	Italy.....	55,115	22,885	11,129
Austria-Hungary.....	124,873	.....	.....	Mexico.....	33,764	.....	.....
Belgium.....	155,373	.....	.....	Netherlands.....	219,819	.....	.....
British India.....	268,648	204,267	191,307	Russia.....	1,453,413	.....	.....
Canada.....	51,370	18,309	2,456	United Kingdom.....	161,798	188	157
China.....	147,468	149,186	167,277	United States.....	1,704,124	735,040	107,063
Denmark.....	15,777	56	.....	Other countries.....	83,814	.....	.....
Egypt.....	161,624	181,434	11	Total.....	5,681,538	.....	.....
France.....	476,863	12,076	5,323				
Germany.....	525,108	.....	.....				

IMPORTS.

<i>Into—</i>				<i>Into—</i>			
Austria-Hungary.....	53,673	.....	.....	Japan.....	189,868	186,382	185,118
Belgium.....	543,648	.....	.....	Netherlands.....	707,116	.....	.....
Canada.....	7,752	2,348	44,249	Norway.....	55,112	69,521	.....
Denmark.....	1,002,329	339,006	.....	Sweden.....	346,754	73,414	.....
Dutch East Indies.....	2,509	1,279	.....	Switzerland.....	69,352	62,476	24,808
Finland.....	25,333	.....	.....	United Kingdom.....	790,865	476,847	24,232
France.....	288,968	6,352	33,821	Other countries.....	31,757	.....	.....
Germany.....	1,686,416	.....	.....	Total.....	5,812,002	.....	.....
Italy.....	10,550	28	4,393				

ROSIN.

TABLE 214.—Rosin: International trade, calendar years 1909-1913, 1917, and 1918.

[For rosin, only the resinous substance known as "rosin" in the exports of the United States is taken. See "General note," Table 101.]

EXPORTS.

[000 omitted.]

Country.	Average, 1909-1913.	1917 (prelim.)	1918 (prelim.)	Country.	Average, 1909-1913.	1917 (prelim.)	1918 (prelim.)
<i>From—</i>	<i>Pounds.</i>	<i>Pounds.</i>	<i>Pounds.</i>	<i>From—</i>	<i>Pounds.</i>	<i>Pounds.</i>	<i>Pounds.</i>
Austria-Hungary.....	2,205	.....	.....	Spain.....	20,073	23,006	11,787
Belgium.....	32,830	.....	.....	United States.....	655,520	418,150	218,128
France.....	118,286	60,102	41,049	Other countries.....	1,568	.....	.....
Germany.....	50,110	.....	.....	Total.....	950,381	.....	.....
Greece.....	10,423	6,194	.....				
Netherlands.....	59,366	.....	.....				

IMPORTS.

<i>Into—</i>				<i>Into—</i>			
Argentina.....	32,719	44,105	31,106	Italy.....	34,171	45,482	23,266
Australia.....	13,724	17,951	.....	Japan.....	10,073	26,083	26,142
Austria-Hungary.....	75,705	.....	.....	Netherlands.....	73,991	.....	.....
Belgium.....	47,163	.....	.....	Norway.....	6,732	2,054	.....
Brazil.....	36,905	78	.....	Roumania.....	5,004	.....	.....
British India.....	6,171	4,403	3,539	Russia.....	68,429	.....	.....
Canada.....	25,506	33,873	34,255	Serbia.....	1,162	.....	.....
Chile.....	7,410	4,136	.....	Spain.....	1,827	198	198
Cuba.....	4,123	7,851	6,831	Switzerland.....	4,983	5,581	9,108
Denmark.....	3,236	1,605	727	United Kingdom.....	166,075	188,881	84,193
Dutch East Indies.....	15,039	10,179	.....	Other countries.....	18,734	.....	.....
Finland.....	6,027	.....	.....	Total.....	900,441	.....	.....
France.....	2,432	536	1,158				
Germany.....	233,100	.....	.....				

## TURPENTINE.

TABLE 215.—Turpentine (spirits): International trade, calendar years, 1909–1913, 1917, and 1918.

["Spirits of turpentine" includes only "spirits" or "oil" of turpentine, and for Russia, skipidar; it excludes crude turpentine, pitch, and, for Russia, turpentine. See "General note," Table 101.]

## EXPORTS.

[000 omitted.]

Country.	Average, 1909– 1913.	1917 (pre- lim.).	1918 (pre- lim.).	Country.	Average, 1909– 1913.	1917 (pre- lim.).	1918 (pre- lim.).
<i>From—</i>	<i>Gallons.</i>	<i>Gallons.</i>	<i>Gallons.</i>	<i>From—</i>	<i>Gallons.</i>	<i>Gallons.</i>	<i>Gallons.</i>
Belgium.....	1,144	.....	.....	Spain.....	1,156	1,260	710
France.....	2,594	448	860	United States.....	17,868	6,517	3,717
Germany.....	460	.....	.....	Other countries.....	649	.....	.....
Netherlands.....	2,750	.....	.....	Total.....	28,943	.....	.....
Russia.....	2,322	.....	.....				

## IMPORTS.

<i>Into—</i>				<i>Into—</i>			
Argentine.....	554	576	254	New Zealand.....	178	91	95
Australia.....	564	634	.....	Russia.....	273	.....	.....
Austria-Hungary.....	2,581	.....	.....	Sweden.....	134	4	.....
Belgium.....	1,932	.....	.....	Switzerland.....	466	376	439
Canada.....	1,175	1,247	1,209	United Kingdom..	7,782	3,097	960
Chile.....	198	( <sup>1</sup> )	.....	Other countries.....	1,057	.....	.....
Germany.....	9,368	.....	.....	Total.....	31,200	.....	.....
Italy.....	940	702	673				
Netherlands.....	3,998	.....	.....				

<sup>1</sup> Less than 500 gallons.

## INDIA RUBBER.

TABLE 216.—India rubber: International trade, calendar years 1909–1918.

[Figures for india rubber include "india rubber," so called, and caoutchouc, caucho, jebe (Peru), hule (Mexico), borracha, massaranduba, mangabeira, manicoba, sorva, and seringa (Brazil), gomelastiek (Dutch East Indies), caura, ser nambi (Venezuela). See "General note," Table 101.]

## EXPORTS.

[000 omitted.]

Country.	Average, 1909– 1913.	1917 (pre- lim.)	1918 (pre- lim.)	Country.	Average, 1909– 1913.	1917 (pre- lim.)	1918 (pre- lim.)
<i>From—</i>	<i>Pounds.</i>	<i>Pounds.</i>	<i>Pounds.</i>	<i>From—</i>	<i>Pounds.</i>	<i>Pounds.</i>	<i>Pounds.</i>
Angola.....	5,620	.....	.....	Kameran.....	6,409	.....	.....
Belgium Kongo.....	7,755	.....	.....	Mexico.....	14,262	.....	.....
Belgium.....	20,749	.....	.....	Netherlands.....	7,172	.....	.....
Bolivia.....	8,395	.....	.....	Peru.....	5,030	7,263	3,828
Brazil.....	84,938	74,912	49,961	Senegal.....	1,087	.....	.....
Ceylon.....	10,953	75,781	50,935	Singapore.....	5,843	.....	.....
Dutch East Indies..	7,679	100,779	.....	Nigeria.....	3,054	.....	.....
Ecuador.....	1,040	910	.....	Negri Sembilan...	3,995	.....	.....
France.....	21,615	7,539	6,046	Perak.....	7,313	.....	.....
French Guiana.....	3,937	.....	.....	Selangor.....	13,736	.....	.....
French Kongo.....	3,797	.....	.....	Venezuela.....	772	404	81
Germany.....	9,844	.....	.....	Other countries.....	28,936	.....	.....
Gold Coast.....	2,393	.....	.....	Total.....	289,064	.....	.....
Ivory Coast.....	2,740	.....	.....				

## IMPORTS.

<i>Into—</i>				<i>Into—</i>			
Austria-Hungary....	6,696	.....	.....	Russia.....	19,131	.....	.....
Belgium.....	25,891	.....	.....	United Kingdom...	43,141	58,122	67,298
Canada.....	3,945	13,641	18,216	United States.....	100,180	405,638	325,959
France.....	32,704	49,827	41,792	Other countries.....	12,424	.....	.....
Germany.....	42,004	.....	.....	Total.....	302,319	.....	.....
Italy.....	5,381	13,508	16,635				
Netherlands.....	10,822	.....	.....				

SILK.

TABLE 217.—Production of raw silk in undermentioned countries, 1909–1918.  
[Estimates of the Silk Merchants' Union, Lyon, France.]

Country.	Average, 1909–1913.	1915	1916	1917	1918
<b>Western Europe:</b>					
Italy.....	<i>Pounds.</i> 8,524,000	<i>Pounds.</i> 6,349,000	<i>Pounds.</i> 7,963,000	<i>Pounds.</i> 6,217,000	<i>Pounds.</i> 5,942,000
France.....	992,000	287,000	485,000	452,000	529,000
Spain.....	182,000	121,000	198,000	154,000	165,000
Austria.....	} 726,000	{ 187,000	187,000	188,000	188,000
Hungary.....					
Total.....	10,424,000	7,087,000	8,976,000	7,154,000	6,967,000
<b>Levant and Central Asia:</b>					
Broussa and Anatolia.....	1,137,000	386,000	386,000	.....	.....
Syria and Cyprus.....	1,058,000	772,000	772,000	.....	.....
Other Provinces of Asiatic Turkey.....	294,000	143,000	143,000	.....	.....
Turkey in Europe <sup>1</sup> .....	<sup>2</sup> 187,000	66,000	66,000	.....	.....
Saloniki and Adrianople.....	<sup>3</sup> 758,000	.....	.....	.....	.....
Balkan States (Bulgaria, Servia, and Roumania).....	374,000	220,000	220,000	.....	.....
Greece, Saloniki <sup>1</sup> and Crete.....	182,000	243,000	243,000	.....	.....
Caucasus.....	1,023,000	276,000	276,000	.....	.....
Persia (exports).....	} 1,173,000	{ 77,000	77,000	.....	.....
Turkestan (exports) <sup>4</sup> .....					
Total.....	6,186,000	2,293,000	2,293,000	2,293,000	2,293,000
<b>Far East:</b>					
China—					
Exports from Shanghai.....	12,576,000	12,037,000	10,340,000	10,097,000	10,251,000
Exports from Canton.....	5,146,000	4,068,000	5,346,000	5,170,000	4,134,000
Japan—					
Exports from Yokohama.....	21,898,000	26,466,000	29,431,000	34,050,000	31,416,000
British India—					
Exports from Bengal and Cashmere.....	428,000	192,000	254,000	232,000	242,000
Indo-China—					
Exports from Saigon, Haiphong, etc.....	<sup>5</sup> 31,000	29,000	7,000	11,000	11,000
Total.....	40,079,000	42,792,000	45,378,000	49,560,000	46,054,000
Grand total.....	56,689,000	52,172,000	56,647,000	59,007,000	55,314,000

<sup>1</sup> Prior to 1913 Turkey in Europe included the vilayet of Saloniki, which belonged to Greece in subsequent years.

<sup>2</sup> For 1913 only.

<sup>3</sup> For four years, 1909–1912.

<sup>4</sup> Including "Central Asia" subsequent to 1911.

<sup>5</sup> For three years, 1911–1913.

WOOD PULP.

TABLE 218.—Wood pulp: International trade, calendar years 1909–1918.

[All kinds of pulp from wood have been taken for this item, but no pulp made from other fibrous substances. See "General note," Table 101.]

EXPORTS.

[000 omitted.]

Country.	Average, 1909–1913.	1917 (prelim.)	1918 (prelim.)	Country.	Average, 1909–1913.	1917 (prelim.)	1918 (prelim.)
<i>From—</i>	<i>Pounds.</i>	<i>Pounds.</i>	<i>Pounds.</i>	<i>From—</i>	<i>Pounds.</i>	<i>Pounds.</i>	<i>Pounds.</i>
Austria-Hungary.....	205,364	.....	.....	Sweden.....	1,822,023	1,534,285	.....
Belgium.....	80,647	.....	.....	Switzerland.....	13,072	7,056	4,313
Canada.....	606,203	1,023,607	1,167,822	United States.....	24,309	78,360	44,648
Finland.....	236,881	.....	.....	Other countries.....	75,486	.....	.....
Germany.....	384,709	.....	.....	Total.....	4,938,507	.....	.....
Norway.....	1,437,078	.....	.....				
Russia.....	52,735	.....	.....				

IMPORTS.

<i>Into—</i>	Average, 1909–1913.	1917 (prelim.)	1918 (prelim.)	<i>Into—</i>	Average, 1909–1913.	1917 (prelim.)	1918 (prelim.)
Argentina.....	52,016	29,636	37,293	Russia.....	56,072	.....	.....
Austria-Hungary.....	13,366	.....	.....	Spain.....	92,770	73,712	71,462
Belgium.....	291,254	.....	.....	Sweden.....	9,515	2,752	.....
Denmark.....	110,866	120,555	132,932	Switzerland.....	21,059	23,459	35,348
France.....	836,899	353,417	558,987	United Kingdom.....	1,891,006	866,784	939,337
Germany.....	112,660	.....	.....	United States.....	1,007,239	1,355,682	1,156,418
Italy.....	179,267	43,320	39,531	Other countries.....	85,052	.....	.....
Japan.....	79,260	31,854	63,934	Total.....	4,856,963	.....	.....
Portugal.....	18,662	.....	.....				

# LIVE STOCK, 1919.

## FARM ANIMALS AND THEIR PRODUCTS.

TABLE 219.—Live stock in principal and other countries.

[Latest census or other official figures available, with comparison for earlier years. Census returns are in italics; other official figures are in roman type.]

### PRINCIPAL COUNTRIES.

Country.	Date.	Cattle.	Buffaloes.	Swine.	Sheep.	Goats.	Horses.	Mules.	Asses.
United States:		<i>Thous.</i>	<i>Thous.</i>	<i>Thous.</i>	<i>Thous.</i>	<i>Thous.</i>	<i>Thous.</i>	<i>Thous.</i>	<i>Thous.</i>
On farms.....	Jan. 1, 1919	67,866	.....	75,587	49,863	(1)	21,534	4,925	(1)
	Jan. 1, 1918	67,422	.....	70,978	48,603	(1)	21,555	4,873	(1)
	Jan. 1, 1917	63,617	.....	67,453	48,483	(1)	21,126	4,639	(1)
	Jan. 1, 1916	61,920	.....	67,766	48,625	(1)	21,159	4,593	(1)
	Jan. 1, 1915	58,329	.....	64,618	49,956	(1)	21,195	4,479	(1)
	Apr. 15, 1910	61,804	.....	58,186	52,448	2,915	19,833	4,210	106
Not on farms.....	do.....	1,879	.....	1,288	391	115	3,183	270	17
Alaska (on farms and not on farms).....	Jan. 1, 1910	1	2 22	(3)	(3)	(3)	2	(3)	(3)
Hawaii (on farms and not on farms).....	Apr. 15, 1910	149	.....	31	77	5	28	9	3
Porto Rico (on farms and not on farms).....	do.....	316	.....	106	6	49	58	5	1
Virgin Islands:									
On farms.....	Nov. 1, 1917	12	.....	2	1	2	2	2	1
Not on farms.....	do.....	(a)	.....	(a)	(3)	1	(3)	(3)	(3)
Algeria.....	Dec. 31, 1912	1,107	.....	114	8,338	3,772	221	192	271
	Sept. —, 1910	1,128	.....	109	9,042	3,990	230	192	276
	Sept. —, 1905	1,067	.....	91	9,063	4,030	221	174	278
	Sept. —, 1900	993	.....	82	6,724	3,563	202	147	263
	Sept. —, 1895	1,121	.....	84	7,892	3,545	217	142	287
Argentina.....	June 1, 1914	25,867	.....	2,901	43,225	4,395	8,324	565	265
	May 1, 1908	29,124	.....	1,404	67,384	3,947	7,538	465	285
	May —, 1895	21,702	.....	653	74,380	2,749	4,447	285	198
	1888	21,962	.....	394	66,706	1,894	4,234	417	.....
Australia.....	June 30, 1919	11,040	.....	.....	91,676	.....	.....	.....	.....
	Dec. 31, 1917	11,956	.....	1,169	84,965	.....	2,499	.....	.....
	Dec. 31, 1916	10,468	.....	1,006	76,669	.....	2,437	.....	.....
	Dec. 31, 1915	9,931	.....	754	69,257	4 262	2,378	8	.....
	Dec. 31, 1914	11,052	.....	862	78,600	.....	2,521	(1)	(1)
	Dec. 31, 1910	11,745	.....	1,026	92,047	314	2,166	5	.....
	Dec. 31, 1905	8,528	.....	1,015	74,541	(1)	1,675	(1)	(1)
	Dec. 31, 1900	8,640	.....	950	70,603	(1)	1,610	(1)	(1)
	Dec. 31, 1895	11,767	.....	823	90,690	(1)	1,680	(1)	(1)
	1890	10,300	.....	891	97,881	(1)	1,522	(1)	(1)
Austria-Hungary:									
Austria.....	Dec. 31, 1910	9,159	1	6,432	2,428	1,257	1,803	21	53
	Dec. 31, 1900	9,511	(1)	4,683	2,621	1,020	1,716	20	46
	Dec. 31, 1890	8,644	(1)	3,550	3,187	1,036	1,548	17	41
	Dec. 31, 1880	8,584	(1)	2,722	3,841	1,007	1,463	50	.....
Hungary.....	Apr. —, 1913	6,045	162	6,825	6,560	269	2,005	1	16
	Feb. 28, 1911	6,184	.....	6,416	7,698	331	2,001	1	18
	Nov. 20, 1895	5,830	.....	6,447	7,527	237	1,997	22	.....
	1884	4,879	.....	4,804	10,595	270	1,749	23	.....
Croatia-Slavonia.....	Mar. 24, 1911	1,135	.....	1,164	850	96	350	3	.....
	Dec. 31, 1895	909	.....	883	596	22	311	1	2
Bosnia-Herzegovina..	Oct. 10, 1910	1,309	1	527	2,499	1,393	222	(3)	6
	Nov. 10, 1895	1,416	1	662	3,231	1,447	231	1	5
Belgium.....	Dec. 31, 1913	1,849	.....	1,412	(1)	(1)	267	(1)	.....
	Dec. 31, 1910	1,880	.....	1,494	185	218	317	11	.....
	Dec. 31, 1895	1,421	.....	1,163	236	241	272	7	.....
	Dec. 31, 1880	1,383	.....	646	365	(1)	272	(1)	(1)
Brazil.....	1916	28,962	.....	17,329	7,205	6,920	6,065	3,222	.....
	1912-13	30,705	.....	18,399	10,653	10,049	7,289	3,208	.....
Bulgaria.....	Dec. 31, 1910	1,603	415	527	8,632	1,459	478	12	117
	Dec. 31, 1905	1,696	477	465	8,131	1,384	538	12	128
	Dec. 31, 1900	1,596	431	368	7,015	1,405	495	9	104
	Dec. 31, 1892	1,426	342	462	6,868	1,264	344	8	82

<sup>1</sup> No official statistics.

<sup>2</sup> Reindeer.

<sup>3</sup> Less than 500.

<sup>4</sup> Dec. 31, 1913.

TABLE 219.—Live stock in principal and other countries—Continued.

PRINCIPAL COUNTRIES—Continued.

Country.	Date.	Cattle.	Buffaloes.	Swine.	Sheep.	Goats.	Horses.	Mules.	Asses.	
		<i>Thous.</i>	<i>Thous.</i>	<i>Thous.</i>	<i>Thous.</i>	<i>Thous.</i>	<i>Thous.</i>	<i>Thous.</i>	<i>Thous.</i>	
Canada.....	June 30, 1918	10,051		4,290	3,053	(1)	3,609	(1)	(1)	
	June 30, 1917	7,920		3,619	2,369	(1)	3,413	(1)	(1)	
	June 30, 1916	6,594		3,475	2,023	(1)	3,258	(1)	(1)	
	June 30, 1915	6,066		3,112	2,039	(1)	2,996	(1)	(1)	
	June 1, 1911	6,533		3,610	2,175	(1)	2,596	(1)	(1)	
	June 30, 1901	5,576		2,354	2,510	(1)	1,577	(1)	(1)	
	1891	4,121		1,734	2,564	(1)	1,471	(1)	(1)	
1881	3,515		1,208	3,049	(1)	1,059	(1)	(1)		
Denmark.....	Feb. 10, 1919			583						
	Feb. 20, 1918	2,142		513	247	(1)	511	(1)	(1)	
	Feb. 1, 1917	2,453		1,981	270	(1)	538	(1)	(1)	
	Feb. 29, 1916	2,290		1,983	255	(1)	515	(1)	(1)	
	May 15, 1915	2,417		1,919	533	(1)	526	(1)	(1)	
	July 15, 1914	2,463		2,497	515	41	567	(1)	(1)	
	July 15, 1909	2,254		1,468	727	40	535	(1)	(1)	
	July 15, 1903	1,840		1,457	877	38	487	(1)	(1)	
	July 15, 1898	1,745		1,168	1,074	32	449	(1)	(1)	
	Aug. to Sept., 1916.	493	515	(1)	688	263	34	17	526	
1915	554	538	(1)	755	290	35	21	547		
1914	601	568	(1)	(1)	(1)	(1)	(1)	(1)		
1913	637	633	(1)	(1)	(1)	(1)	(1)	(1)		
Finland.....	1910	1,573	2 120	418	1,309	13	361	(1)	(1)	
	1905	1,481	2 142	220	938	6	324	(1)	(1)	
	1900	1,428	2 119	211	985	8	311	(1)	(1)	
1890	1,305	2 86	194	1,054	15	293	(1)	(1)		
France.....	June 30, 1918	13,315		4,021	9,496					
	July 1, 1917	12,443		4,200	10,587		2,283	150	325	
	Dec. 31, 1916	12,342		4,362	10,845	1,177	2,246	148	327	
	Dec. 31, 1915	12,414		4,916	12,379	1,230	2,156	144	324	
	Dec. 31, 1914	12,668		5,926	14,038	1,317	2,105	152	337	
	Dec. 31, 1913	14,807		7,048	16,213	1,453	3,231	193	360	
	Dec. 31, 1910	14,533		6,900	17,111	1,418	3,198	193	361	
	Dec. 31, 1900	14,521		6,740	20,180	1,558	2,903	205	356	
	Nov. 30, 1892	13,709		7,421	21,116	1,845	2,795	217	369	
	1882	12,997		7,147	23,809	1,851	2,838	251	296	
	1862	12,812		6,038	29,530	1,726	2,914	(1)	(1)	
	Dec. 4, 1918	17,227		10,080	45,299					
	Dec. 1, 1915	20,317		17,287	5,073	3,438	3,342	(1)	(1)	
Dec. 1, 1914	21,829		25,341	5,471	3,538	3,435	(1)	(1)		
Dec. 1, 1913	20,994		25,659	5,521	3,548	3,227	(1)	(1)		
Dec. 2, 1912	20,182		21,924	5,803	3,410	4,523		13		
Dec. 2, 1907	20,631		22,147	7,704	3,534	4,345		11		
Dec. 1, 1904	19,332		18,921	7,907	3,330	4,267	(1)	(1)		
Dec. 1, 1900	18,940		16,807	9,693	3,267	4,195		8		
Dec. 1, 1897	18,491		14,275	10,867	(1)	4,038	(1)	(1)		
Dec. 1, 1892	17,556		12,174	13,590	3,092	3,856		7		
Jan. 10, 1883	15,787		9,206	19,190	3,641	3,523		10		
1914	300	(1)	227	3,547	2,638	149	80	(1)		
133										
Greece.....	1916-1917	6 130,145	7 19,280	(1)	22,923	33,366	1,681	70	1,537	
	1915-1916	6 129,742	7 19,206	(1)	22,970	33,607	1,673	69	1,538	
	1914-1915	6 128,310	7 19,025	(1)	23,016	33,338	1,653	71	1,512	
	1913-1914	6 125,042	7 18,235	(1)	23,092	30,673	1,643	86	1,501	
	1910-1911	6 94,664	7 16,628	(1)	22,922	28,518	1,524	110	1,342	
	1904-1905	6 77,111	7 12,871	(1)	17,562	24,803	1,278	54	1,177	
	1899-1900	6 72,666	7 12,120	(1)	17,805	19,005	1,308		1,227	
	1894-1895	6 67,045	7 11,826	(1)	17,260	15,272	1,134		1,102	
	Native States.....	1913-1914	6 12,236	7 1,765	(1)			175		181
		1909-1910	6 10,391	7 1,559	(1)			141		155
		1904-1905	6 8,178	7 1,347	(1)			92		129
		1900-1901	6 7,397	7 1,228	(1)			85		115
	Italy.....	Apr. 7, 1918	6,186	(1)	2,337					
1914		6,646		2,722	11,752					
Mar. 10, 1908		6,199	19	2,508	13,824				2,235	
Feb. 13, 1881	4,772	11	1,164							
Japanese Empire: Japan.....	Dec. 31, 1916	1,343	(1)	328	3	109	1,572	(1)	(1)	
	Dec. 31, 1915	1,388	(1)	333	3	97	1,580	(1)	(1)	
	Dec. 31, 1914	1,387	(1)	332	3	95	1,579	(1)	(1)	
	Dec. 31, 1913	1,389	(1)	310	3	89	1,582	(1)	(1)	
	Dec. 31, 1910	1,384	(1)	279	3	92	1,565	(1)	(1)	
	Dec. 31, 1905	1,168	(1)	228	4	72	1,368	(1)	(1)	
	Dec. 31, 1900	1,261	(1)	181	2	60	1,542	(1)	(1)	

<sup>1</sup> No official statistics.  
<sup>2</sup> Reindeer.

<sup>3</sup> Excludes invaded area.

<sup>4</sup> Exclusive of Alsace-Lorraine.

<sup>5</sup> Including Army horses.

<sup>6</sup> Including young buffaloes.

<sup>7</sup> Not including young buffaloes.

TABLE 219.—Live stock in principal and other countries—Continued.

## PRINCIPAL COUNTRIES—Continued.

Country.	Date.	Cattle.	Buffaloes.	Swine.	Sheep.	Goats.	Horses.	Mules.	Asses.	
Japanese Empire—Continued.										
		<i>Thous.</i>	<i>Thous.</i>	<i>Thous.</i>	<i>Thous.</i>	<i>Thous.</i>	<i>Thous.</i>	<i>Thous.</i>	<i>Thous.</i>	
Chosen (Korea)...	Dec. 31, 1915	1,354	( <sup>1</sup> )	767	.....	24	55	.....	13	
	Dec. 31, 1914	1,338	( <sup>1</sup> )	758	.....	12	53	.....	14	
	Dec. 31, 1913	1,211	( <sup>1</sup> )	761	.....	10	51	.....	13	
	Dec. 31, 1910	704	( <sup>1</sup> )	566	.....	7	40	( <sup>1</sup> )	( <sup>1</sup> )	
Formosa (Taiwan)	Dec. 31, 1916	2	385	1,295	( <sup>2</sup> )	118	( <sup>2</sup> )	.....	.....	
	Dec. 31, 1915	2	397	1,319	( <sup>2</sup> )	117	( <sup>2</sup> )	.....	.....	
	Dec. 31, 1914	2	398	1,313	( <sup>2</sup> )	125	( <sup>2</sup> )	.....	.....	
	Dec. 31, 1905	( <sup>2</sup> )	341	1,018	( <sup>2</sup> )	108	( <sup>2</sup> )	.....	.....	
Luxemburg.....	Nov. 8, 1918	108	.....	95	6	15	17	.....	.....	
	Oct. 18, 1917	114	.....	114	4	14	17	.....	.....	
Mexico.....	June 30, 1902	5,142	.....	616	3,424	4,206	859	334	288	
Netherlands.....	Mar. 1919	1,969	.....	450	437	.....	362	( <sup>1</sup> )	( <sup>1</sup> )	
	Aug. 1918	2,049	.....	600	642	311	378	( <sup>1</sup> )	( <sup>1</sup> )	
	Apr. 11, 1917	2,304	.....	1,185	521	.....	.....	( <sup>1</sup> )	( <sup>1</sup> )	
	May 1915	2,390	.....	1,487	( <sup>1</sup> )	( <sup>1</sup> )	( <sup>1</sup> )	( <sup>1</sup> )	( <sup>1</sup> )	
	June 1913	2,097	.....	1,350	842	232	334	( <sup>1</sup> )	( <sup>1</sup> )	
	May 20, 1910	2,027	.....	1,260	889	224	227	( <sup>1</sup> )	( <sup>1</sup> )	
	June 20, 1910	.....	.....	.....	.....	.....	.....	.....	.....	
	Dec. 31, 1904	1,691	.....	862	607	166	295	( <sup>1</sup> )	( <sup>1</sup> )	
	Dec. 31, 1900	1,656	.....	747	771	180	295	( <sup>1</sup> )	( <sup>1</sup> )	
	Dec. 31, 1890	1,533	.....	579	819	165	273	( <sup>1</sup> )	( <sup>1</sup> )	
New Zealand.....	Jan. 31, 1918	2,888	.....	258	26,538	.....	379	.....	.....	
	Jan. 31, 1917	2,503	.....	278	24,753	.....	367	.....	.....	
	Jan. 31, 1916	2,417	.....	298	24,788	17	371	( <sup>2</sup> )	( <sup>2</sup> )	
	Apr. 1, 1911	2,020	.....	349	.....	6	404	( <sup>2</sup> )	( <sup>2</sup> )	
	Apr. 30, 1911	.....	.....	.....	23,996	.....	.....	.....	.....	
	Apr. 30, 1905	.....	.....	.....	19,131	.....	.....	.....	.....	
	Oct. 1905	1,811	.....	250	.....	.....	327	( <sup>2</sup> )	( <sup>2</sup> )	
	Apr. 30, 1900	.....	.....	.....	19,355	( <sup>1</sup> )	.....	( <sup>2</sup> )	( <sup>2</sup> )	
	Oct. 1900	1,257	.....	251	.....	( <sup>1</sup> )	266	( <sup>2</sup> )	( <sup>2</sup> )	
	Apr. 1895	.....	.....	.....	19,827	( <sup>1</sup> )	.....	( <sup>2</sup> )	( <sup>2</sup> )	
	1895	1,048	.....	240	.....	( <sup>1</sup> )	237	( <sup>2</sup> )	( <sup>2</sup> )	
	1891	832	.....	309	18,128	9	211	( <sup>2</sup> )	( <sup>2</sup> )	
Norway.....	June 20, 1918	1,054	( <sup>1</sup> )	225	1,216	204	221	( <sup>1</sup> )	( <sup>1</sup> )	
	Sept. 30, 1916	1,119	( <sup>1</sup> )	221	1,281	230	189	( <sup>1</sup> )	( <sup>1</sup> )	
	Sept. 30, 1915	1,121	( <sup>1</sup> )	209	1,330	240	186	( <sup>1</sup> )	( <sup>1</sup> )	
	Sept. 30, 1914	1,146	( <sup>1</sup> )	228	1,327	237	182	( <sup>1</sup> )	( <sup>1</sup> )	
	Sept. 30, 1910	1,134	( <sup>1</sup> )	334	1,398	288	168	( <sup>1</sup> )	( <sup>1</sup> )	
	Sept. 30, 1907	1,089	<sup>3</sup> 143	307	1,391	296	164	( <sup>1</sup> )	( <sup>1</sup> )	
	1900	950	<sup>3</sup> 109	165	919	215	173	( <sup>1</sup> )	( <sup>1</sup> )	
	1890	1,006	<sup>3</sup> 170	121	1,418	272	151	( <sup>1</sup> )	( <sup>1</sup> )	
Paraguay.....	1915	5,249	.....	61	600	87	478	17	18	
	1902	2,461	.....	37	222	50	218	9	2	
	1889	2,283	.....	24	214	32	183	3	5	
	1886	730	.....	12	32	11	62	2	4	
	1877	201	.....	3	7	.....	21	1	2	
Philippine Islands....	Dec. 31, 1916	.....	.....	.....	.....	.....	.....	.....	.....	
	Dec. 31, 1915	534	1,222	2,521	129	644	223	( <sup>1</sup> )	( <sup>1</sup> )	
	Dec. 31, 1910	270	757	1,682	94	441	143	( <sup>1</sup> )	( <sup>1</sup> )	
	Dec. 31, 1902	128	641	1,179	30	124	144	( <sup>1</sup> )	( <sup>1</sup> )	
Portugal.....	Oct. 1906	703	( <sup>1</sup> )	1,111	3,073	1,034	88	58	144	
	1870	625	( <sup>1</sup> )	971	2,977	937	87	51	138	
Rumania.....	Apr. 1916	2,938	.....	1,382	7,811	301	1,219	( <sup>2</sup> )	12	
	1911	2,667	.....	1,021	5,269	187	825	4	.....	
	1907	2,585	.....	1,124	5,105	191	808	5	.....	
	Dec. 1900	2,545	44	1,709	5,655	233	864	1	7	
	1890	2,520	.....	926	5,002	210	595	6	.....	
	1884	2,376	.....	886	4,655	245	533	2	.....	
Russian Empire.										
Russia, European.	1914	32,704	( <sup>1</sup> )	11,581	37,240	( <sup>1</sup> )	22,529	( <sup>1</sup> )	( <sup>1</sup> )	
	1913	31,974	<sup>3</sup> 605	13,458	41,426	873	22,771	6	7	
	1910	31,315	<sup>3</sup> 462	12,049	40,734	857	21,868	5	2	
	1900	31,661	<sup>3</sup> 350	11,761	47,628	1,017	19,744	1	2	
	1890	25,528	( <sup>1</sup> )	9,554	46,052	( <sup>1</sup> )	19,779	( <sup>2</sup> )	( <sup>2</sup> )	
Poland.....	In Sum- mer.	1881	22,122	( <sup>1</sup> )	9,265	45,522	1,157	15,534	( <sup>2</sup> )	( <sup>2</sup> )
	1914	2,014	( <sup>1</sup> )	452	565	( <sup>1</sup> )	1,098	.....	.....	
	1913	2,011	( <sup>2</sup> )	491	683	9	1,116	( <sup>2</sup> )	( <sup>2</sup> )	
	1910	2,301	( <sup>2</sup> )	612	1,050	9	1,222	( <sup>2</sup> )	( <sup>2</sup> )	
Russia, Asiatic (33 governments of the Caucasus, Central Asia, and Siberia.....	1900	2,823	( <sup>2</sup> )	1,402	2,823	11	1,392	( <sup>2</sup> )	1	
	1890	3,013	( <sup>2</sup> )	1,499	3,755	( <sup>1</sup> )	1,207	( <sup>2</sup> )	.....	
	1881	5,055	( <sup>2</sup> )	706	3,375	10	1,037	.....	.....	
	1914	17,334	( <sup>1</sup> )	2,962	34,468	( <sup>1</sup> )	11,346	( <sup>1</sup> )	( <sup>1</sup> )	
	1913	18,404	( <sup>1</sup> )	2,895	38,696	4,791	11,959	( <sup>1</sup> )	( <sup>1</sup> )	
Serbia.....	Dec. 31, 1910	957	7	866	3,819	631	153	1	.....	
	Dec. 31, 1905	963	7	908	3,160	510	174	1	1	

<sup>1</sup> No official statistics.<sup>2</sup> Less than 500.<sup>3</sup> Reindeer.



TABLE 219.—Live stock in principal and other countries—Continued.

PRINCIPAL COUNTRIES—Continued.

Country.	Date.	Cattle.	Buffaloes.	Swine.	Sheep.	Goats.	Horses.	Mules.	Asses.
		<i>Thous.</i>	<i>Thous.</i>	<i>Thous.</i>	<i>Thous.</i>	<i>Thous.</i>	<i>Thous.</i>	<i>Thous.</i>	<i>Thous.</i>
Spain.....	1916	3,071	.....	2,814	16,012	3,207	489	913	839
	1914	2,743	.....	2,810	16,128	3,265	525	984	841
	1913	2,879	.....	2,710	16,441	3,394	542	948	849
	Dec. 31, 1910	2,369	.....	2,424	15,117	3,216	520	880	868
	Dec. 31, 1906	2,497	.....	2,080	13,481	2,440	440	802	744
	1891	2,218	.....	1,928	13,359	2,534	597	768	754
Sweden.....	June 1, 1918	2,584	.....	634	1,409	133	715	(1)	(1)
	June 1, 1917	3,020	.....	1,030	1,344	136	715	(1)	(1)
	June 1, 1916	2,913	.....	1,065	1,198	132	701	(1)	(1)
	Dec. 31, 1914	2,761	.....	1,015	993	77	603	(1)	(1)
	Dec. 31, 1913	2,721	.....	968	988	71	596	(1)	(1)
	Dec. 31, 1910	2,748	<sup>2</sup> 273	957	1,004	69	587	(1)	(1)
	Dec. 31, 1905	2,550	<sup>2</sup> 226	830	1,074	67	555	(1)	(1)
	1900	2,583	<sup>2</sup> 232	806	1,261	80	533	(1)	(1)
	1890	2,399	<sup>2</sup> 288	645	1,351	87	487	(1)	(1)
Switzerland.....	Apr. 19, 1918	1,530	.....	366	230	356	129	3	.....
	Apr. 19, 1916	1,616	.....	544	172	358	137	3	.....
	Apr. 21, 1911	1,443	.....	570	161	341	144	3	.....
	Apr. 20, 1906	1,498	.....	549	210	362	135	3	.....
	Apr. 19, 1901	1,340	.....	555	219	355	125	3	.....
Turkey, European and Asiatic.	1913	2,398	164	31	(1)	(1)	(1)	(1)	(1)
	1912	(1)	(1)	73	27,095	20,269	(1)	(1)	(1)
	1910	(1)	(1)	175	27,662	21,283	(1)	(1)	(1)
	1905	(1)	(1)	196	23,614	16,411	(1)	(1)	(1)
Union of South Africa.	1916	(1)	(1)	(1)	31,981	8,962	(1)	(1)	(1)
	Dec. 31, 1915	(1)	(1)	(1)	31,434	8,918	(1)	(1)	(1)
	Dec. 31, 1913	(1)	(1)	(1)	35,711	11,521	(1)	(1)	(1)
	May 7, 1911	5,797	(1)	1,082	30,657	11,763	719	94	337
	1904	3,500	(1)	679	16,323	9,771	450	135	143
United Kingdom.....	June, 1918	12,311	.....	2,809	27,063	277	1,916	26	232
	1917	12,382	.....	3,008	27,867	269	1,880	25	228
	1916	12,451	.....	3,616	28,850	293	1,834	28	230
	1915	12,171	.....	3,795	28,276	243	1,712	29	227
	1914	12,185	.....	3,953	27,964	242	1,851	31	245
	1910	11,765	.....	3,561	31,165	243	2,095	31	241
Uruguay.....	1916	7,803	.....	.....	.....	.....	.....	.....	.....
	1908	8,193	.....	180	26,286	20	556	18	.....
	1900	6,827	.....	94	18,609	20	561	23	.....
	1860	3,632	.....	6	1,990	5	518	8	.....

OTHER COUNTRIES.

Azores and Madeira Islands.....	1900	89	.....	93	87	38	2	3	9
Basutoland.....	1911	437	.....	(1)	1,365	(1)	88	(1)	(1)
Bechuanaland Protectorate.....	1911	324	.....	(1)	358	.....	.....	4	.....
Bolivia.....	1913	.....	.....	.....	1,750	.....	.....	.....	.....
British Guiana.....	Mar. 31, 1916	98	.....	14	22	15	1	2	6
Ceylon.....	1915	1,501	.....	70	90	183	4	(1)	(1)
Chile.....	Dec. 31, 1914	1,944	.....	229	4,545	.....	458	42	.....
Colombia.....	1915	3,035	.....	711	164	.....	526	201	139
Costa Rica.....	1915	333	.....	63	( <sup>3</sup> )	( <sup>3</sup> )	52	( <sup>3</sup> )	( <sup>3</sup> )
Cuba.....	Dec. 31, 1916	3,962	.....	(1)	(1)	(1)	750	58	3
Cyprus.....	Mar. 31, 1916	63	.....	35	282	228	70	.....	.....
Dominican Republic.....	.....	200	.....	.....	50	550	80	.....	.....
Dutch East Indies:									
Java and Madura.....	1913	4,786	.....	(1)	(1)	(1)	274	(1)	(1)
Other possessions.....	1905	449	447	(1)	(1)	(1)	119	(1)	(1)
Dutch Guiana.....	.....	.....	.....	.....	.....	.....	.....	.....	.....
East Africa Protectorate.....	Mar. 31, 1915	900	(1)	4	6,555	4,020	2	(1)	(1)
Falkland Islands.....	1915	8	.....	(1)	691	(1)	4	(1)	(1)
Faroe Islands.....	1914	4	.....	(1)	112	(1)	1	.....	.....
Fiji.....	1915	59	.....	.....	2	12	7	.....	.....
French Guiana.....	1914	400	.....	(1)	150	140	3	(1)	(1)
French Indo-China:									
Annam.....	1914	215	(1)	(1)	(1)	(1)	(1)	(1)	(1)
Cochin-China.....	1914	109	242	709	3	.....	(1)	(1)	(1)
Gambia.....	1907	83	.....	(1)	(1)	(1)	4	(1)	(1)
Guam.....	1913	6	.....	(1)	(1)	(1)	(1)	(1)	(1)

<sup>1</sup> No official statistics.

<sup>2</sup> Reindeer.

<sup>3</sup> Less than 500.

TABLE 219.—Live stock in principal and other countries—Continued.

## OTHER COUNTRIES—Continued.

Country.	Date.	Cattle.	Buffaloes.	Swine.	Sheep.	Goats.	Horses.	Mules.	Asses.
		<i>Thous.</i>	<i>Thous.</i>	<i>Thous.</i>	<i>Thous.</i>	<i>Thous.</i>	<i>Thous.</i>	<i>Thous.</i>	<i>Thous.</i>
Guatemala.....	Dec. 31, 1915	620	.....	103	383	57	116	.....	.....
German East Africa..	1913	3,994	.....	6	6,440	25	( <sup>1</sup> )	( <sup>1</sup> )	25
German S. W. Africa..	1913	206	.....	8	555	517	16	.....	14
Honduras.....	1914	489	.....	180	6	23	68	.....	25
Iceland.....	1914	25	.....	.....	585	1	47	.....	.....
Jamaica.....	1916	115	.....	.....	11	250	.....	.....	21
Madagascar.....	Dec. 31, 1916	.....	<sup>2</sup> 6,912	544	309	200	3	.....	.....
Malta.....	Mar. 31, 1916	5	.....	4	19	20	.....	9	.....
Mauritius.....	1913	41	.....	17	2	37	2	1	( <sup>3</sup> )
Morocco:									
Western.....	1916-17	1,030	.....	51	4,290	1,266	108	43	286
Eastern.....	1915-16	22	.....	( <sup>3</sup> )	664	285	( <sup>3</sup> )	( <sup>3</sup> )	( <sup>3</sup> )
New Foundland.....	1911	39	.....	27	98	17	14	( <sup>3</sup> )	( <sup>3</sup> )
Nicaragua.....	1908	252	.....	12	( <sup>1</sup> )	1	28	6	1
Nyasland Protectorate	1916	82	.....	24	30	131	( <sup>1</sup> )	( <sup>1</sup> )	( <sup>1</sup> )
Panama.....	1916	200	.....	30	.....	5	15	2	.....
Rhodesia.....	1911	500	.....	2	300	602	.....	20	.....
Salvador.....	1906	284	.....	423	21	( <sup>3</sup> )	74	( <sup>3</sup> )	( <sup>3</sup> )
Siam.....	Jan. 1, 1916	2,337	2,120	( <sup>3</sup> )	.....	.....	105	( <sup>3</sup> )	( <sup>3</sup> )
Straits Settlements.....	1914	40	.....	113	35	18	2	( <sup>3</sup> )	( <sup>3</sup> )
Swaziland.....	Mar. 31, 1916	100	.....	9	250	.....	1	2	.....
Togo.....	1913	<sup>2</sup> 65	.....	( <sup>3</sup> )	( <sup>3</sup> )	( <sup>3</sup> )	( <sup>3</sup> )	( <sup>3</sup> )	( <sup>3</sup> )
Trinidad and Tobago..	1914	13	.....	9	2	6	5	5	( <sup>3</sup> )
Tunis.....	Apr. 30, 1916	240	.....	10	1,148	522	31	15	84
Uganda Protectorate..	1914	845	.....	1	678	.....	( <sup>1</sup> )	( <sup>1</sup> )	( <sup>1</sup> )
Venezuela.....	1912	2,004	.....	1,618	177	1,667	191	89	313

<sup>1</sup> Less than 500.<sup>2</sup> Zebus.<sup>3</sup> No official statistics.

TABLE 220.—Hides and skins: International trade, calendar years 1909-1913, 1917, and 1918.

This table gives the classification as found in the original returns, and the summary statements for "All countries" represent the total for each class only so far as it is disclosed in the original returns. The following kinds are included: Alligator, buffalo, calf, camel, cattle, deer, goat and kid, horse and colt, kangaroo, mule and ass, sheep and lamb, and all other kinds except furs, bird skins, sheepskins with wool on, skins of rabbits and hares, and tanned or partly tanned hides and skins. Number of pounds computed from stated number of hides and skins.]

GENERAL NOTE.—Substantially the international trade of the world. It should not be expected that the world export and import totals for any year will agree. Among sources of disagreement are these: (1) Different periods of time covered in the "year" of the various countries; (2) imports received in year subsequent to year of export; (3) want of uniformity in classification of goods among countries; (4) different practices and varying degrees of failure in recording countries of origin and ultimate destination; (5) different practices of recording reexported goods; (6) opposite methods of treating free ports; (7) clerical errors, which, it may be assumed, are not infrequent.

The exports given are domestic exports, and the imports given are imports for consumption as far as it is feasible and consistent so to express the facts. While there are some inevitable omissions, on the other hand there are some duplications because of reshipments that do not appear as such in official reports. For the United Kingdom, import figures refer to imports for consumption, when available, otherwise total imports, less exports, of "foreign and colonial merchandise." Figures for the United States include Alaska, Porto Rico, and Hawaii.

## EXPORTS.

[000 omitted.]

Country.	Average, 1909-1913.	1917 (prelim.).	1918 (prelim.).	Country.	Average, 1909-1913.	1917 (prelim.).	1918 (prelim.).
<i>From—</i>	<i>Pounds.</i>	<i>Pounds.</i>	<i>Pounds.</i>	<i>From—</i>	<i>Pounds.</i>	<i>Pounds.</i>	<i>Pounds.</i>
Argentina.....	293,951	257,655	241,381	Netherlands.....	67,636	.....	.....
Austria-Hungary.....	79,266	.....	.....	New Zealand.....	25,577	22,629	31,742
Belgium.....	117,213	.....	.....	Peru.....	6,194	7,083	3,824
Brazil.....	83,251	77,190	105,378	Russia.....	96,351	.....	.....
British India.....	169,857	130,497	80,524	Singapore.....	6,435	.....	.....
Canada.....	45,469	34,000	21,000	Spain.....	17,457	11,001	4,843
China.....	72,751	107,710	85,893	Sweden.....	24,130	74	.....
Chosen (Korea).....	4,944	.....	.....	Switzerland.....	22,866	1,740	21
Cuba.....	14,292	30,183	28,454	Union of South Africa	50,937	.....	.....
Denmark.....	21,998	5,333	7,312	United Kingdom.....	38,100	11,239	2,364
Dutch East Indies..	16,708	17,059	.....	United States.....	25,432	11,392	5,105
Egypt.....	10,754	8,664	6,386	Uruguay.....	71,107	.....	.....
France.....	131,042	20,312	4,379	Venezuela.....	9,764	10,521	5,032
Germany.....	152,373	.....	.....	Other countries.....	225,838	.....	.....
Italy.....	48,427	928	308				
Mexico.....	41,013	.....	.....	Total.....	1,991,133	.....	.....

TABLE 220.—Hides and skins: International trade, calendar years 1909–1913, 1917, and 1918—Continued.

IMPORTS.

Country.	Average, 1909–1913.	1917 (prelim.).	1918 (prelim.).	Country.	Average, 1909–1913.	1917 (prelim.).	1918 (prelim.).
<i>From—</i>	<i>Pounds.</i>	<i>Pounds.</i>	<i>Pounds.</i>	<i>From—</i>	<i>Pounds.</i>	<i>Pounds.</i>	<i>Pounds.</i>
Austria-Hungary.....	87,568	.....	.....	Norway.....	13,978	5,687	.....
Belgium.....	180,930	.....	.....	Portugal.....	6,803	.....	.....
British India.....	20,377	14,439	12,944	Roumania.....	7,223	.....	.....
Canada.....	46,820	31,872	17,640	Russia.....	110,142	.....	.....
Denmark.....	9,842	3,554	213	Singapore.....	9,332	.....	.....
Finland.....	10,717	.....	.....	Spain.....	19,119	25,490	25,191
France.....	155,508	116,921	44,433	Sweden.....	25,662	2,221	.....
Germany.....	440,199	.....	.....	United Kingdom.....	107,350	185,840	189,052
Greece.....	5,770	2,339	.....	United States.....	514,248	631,066	361,891
Italy.....	53,523	39,866	68,465	Other countries.....	54,398	.....	.....
Japan.....	6,321	12,535	21,789				
Netherlands.....	73,691	.....	.....	Total.....	1,959,521	.....	.....

TABLE 221.—Meat and meat products: International trade, calendar years 1911–1918.

EXPORTS.

[Figures for 1915–1918, inclusive, are subject to revision.]

Exporting country and classification.	Average, 1911–1913.	1915	1916	1917	1918
	<i>Pounds.</i>	<i>Pounds.</i>	<i>Pounds.</i>	<i>Pounds.</i>	<i>Pounds.</i>
<b>Argentina:</b>					
Beef.....	940,299,000	915,072,000	1,059,051,000	1,067,680,000	1,361,499,000
Mutton.....	148,457,000	77,250,000	113,136,000	87,787,000	111,145,000
Pork.....	9,000	2,304,000	3,381,000	4,034,000	3,668,000
Other.....	84,694,000	111,031,000	150,534,000	266,054,000	484,187,000
Total.....	1,173,459,000	1,105,657,000	1,326,102,000	1,425,555,000	1,960,499,000
<b>Australia:<sup>1</sup></b>					
Beef.....	301,882,000	146,863,000	307,545,000	222,814,000	.....
Mutton.....	149,958,000	38,344,000	66,813,000	19,175,000	.....
Pork.....	6,294,000	902,000	2,720,000	6,796,000	.....
Other.....	49,009,000	18,431,000	33,472,000	51,808,000	.....
Total.....	507,143,000	204,540,000	410,550,000	300,593,000	.....
<b>Belgium:</b>					
Beef.....	1,577,000	.....	.....	.....	.....
Pork.....	16,254,000	.....	.....	.....	.....
Other.....	109,226,000	.....	.....	.....	.....
Total.....	127,057,000	.....	.....	.....	.....
<b>Canada:</b>					
Beef.....	6,448,000	30,695,000	46,129,000	84,387,000	126,695,000
Mutton.....	48,000	83,000	188,000	844,000	731,000
Pork.....	47,694,000	156,556,000	211,616,000	233,742,000	158,488,000
Other.....	6,051,000	16,361,000	10,785,000	20,469,000	16,450,000
Total.....	60,241,000	203,695,000	268,718,000	339,442,000	302,364,000
<b>China:</b>					
Beef.....	8,787,000	15,151,000	40,800,000	36,961,000	18,763,000
Pork.....	7,679,000	12,785,000	14,066,000	23,778,000	20,036,000
Other.....	48,218,000	31,302,000	46,227,000	62,437,000	50,396,000
Total.....	64,684,000	59,238,000	101,093,000	123,176,000	89,195,000
<b>Denmark:</b>					
Beef.....	43,485,000	72,509,000	41,800,000	40,352,000	21,801,000
Mutton.....	344,000	810,000	365,000	( <sup>2</sup> )	1,000
Pork.....	297,174,000	322,983,000	245,354,000	187,739,000	6,134,000
Other.....	26,273,000	56,845,000	62,336,000	51,258,000	4,352,000
Total.....	367,276,000	453,147,000	349,855,000	279,349,000	32,288,000

<sup>1</sup> Year beginning July 1, 1915; and subsequently.

<sup>2</sup> Less than 500 pounds.

TABLE 221.—Meat and meat products: International trade, calendar years 1911-1918—Continued.

## EXPORTS—Continued.

Exporting country and classification.	Average, 1911-1913.	1915	1916	1917	1918
<b>Netherlands:</b>	<i>Pounds.</i>	<i>Pounds.</i>	<i>Pounds.</i>	<i>Pounds.</i>	<i>Pounds.</i>
Beef.....	326,176,000	446,395,000	398,977,000	235,731,000	38,647,000
Mutton.....	17,212,000	25,150,000	5,124,000	6,096,000	.....
Pork.....	139,916,000	144,550,000	90,285,000	28,031,000	165,000
Other.....	14,098,000	18,048,000	.....	.....	.....
Total.....	497,402,000	634,143,000	494,386,000	269,858,000	38,812,000
<b>New Zealand:</b>					
Beef.....	80,543,000	146,851,000	62,720,000	128,640,000	119,640,000
Mutton.....	235,509,000	302,218,000	251,245,000	169,645,000	139,575,000
Pork.....	1,049,000	1,363,000	1,179,000	2,123,000	609,000
Other.....	9,437,000	15,019,000	12,833,000	10,927,000	12,705,000
Total.....	326,538,000	465,451,000	327,977,000	311,335,000	272,529,000
<b>Russia:<sup>1</sup></b>					
Beef.....	32,000	1,047,000	.....	.....	.....
Mutton.....	365,000	125,000	.....	.....	.....
Pork.....	28,871,000	5,704,000	1,011,000	.....	.....
Other.....	23,907,000	3,206,000	4,406,000	.....	.....
Total.....	53,175,000	10,082,000	5,417,000	.....	.....
<b>Sweden:</b>					
Beef.....	17,285,000	35,035,000	10,952,000	10,967,000	.....
Mutton.....	100,000	54,000	2,000	5,000	.....
Pork.....	19,445,000	42,518,000	32,190,000	10,507,000	.....
Other.....	2,937,000	11,625,000	4,646,000	2,684,000	.....
Total.....	39,767,000	89,232,000	47,790,000	24,163,000	.....
<b>United Kingdom:</b>					
Beef.....	27,595,000	19,551,000	10,790,000	2,837,000	1,983,000
Pork.....	15,820,000	13,842,000	10,886,000	1,607,000	202,000
Other.....	73,810,000	89,917,000	59,331,000	84,311,000	11,403,000
Total.....	117,225,000	123,310,000	81,007,000	88,755,000	13,588,000
<b>United States:</b>					
Beef.....	213,722,000	534,766,000	391,442,000	402,430,000	792,793,000
Mutton.....	4,146,000	4,231,000	5,258,000	2,862,000	1,631,000
Pork.....	1,019,561,000	1,371,100,000	1,453,966,000	1,299,556,000	2,251,046,000
Other.....	40,094,000	41,830,000	19,491,000	25,753,000	16,416,000
Total.....	1,277,523,000	1,951,927,000	1,870,157,000	1,730,601,000	3,061,886,000
<b>Other countries:</b>					
Beef.....	11,615,000	.....	.....	.....	.....
Mutton.....	546,000	.....	.....	.....	.....
Pork.....	15,566,000	.....	.....	.....	.....
Other.....	59,894,000	.....	.....	.....	.....
Total.....	87,621,000	.....	.....	.....	.....
<b>All countries:</b>					
Beef.....	1,979,446,000	.....	.....	.....	.....
Mutton.....	556,685,000	.....	.....	.....	.....
Pork.....	1,615,332,000	.....	.....	.....	.....
Other.....	547,648,000	.....	.....	.....	.....
Total.....	4,699,111,000	.....	.....	.....	.....

## IMPORTS.

<b>Austria-Hungary:</b>	<i>Pounds.</i>	<i>Pounds.</i>	<i>Pounds.</i>	<i>Pounds.</i>	<i>Pounds.</i>
Beef.....	12,983,000	.....	.....	.....	.....
Pork.....	14,338,000	.....	.....	.....	.....
Other.....	21,948,000	.....	.....	.....	.....
Total.....	49,269,000	.....	.....	.....	.....

<sup>1</sup> For 1916, exports over European frontier only.

TABLE 221.—Meat and meat products: International trade, calendar years 1911-1918—Continued.

IMPORTS—Continued.

Exporting country and classification.	Average, 1911-1913.	1915	1916	1917	1918
Belgium:	<i>Pounds.</i>	<i>Pounds.</i>	<i>Pounds.</i>	<i>Pounds.</i>	<i>Pounds.</i>
Beef.....	6,034,000				
Pork.....	22,232,000				
Other.....	150,854,000				
Total.....	179,120,000				
Brazil:					
Beef.....	47,990,000	17,117,000	3,541,000	4,189,000	
Pork.....	5,103,000	1,477,000	1,100,000	347,000	
Other.....	920,000	214,000	125,000	52,000	
Total.....	54,013,000	18,808,000	4,766,000	4,588,000	
Canada:					
Beef.....	3,091,000	5,623,000	9,783,000	19,434,000	9,540,000
Mutton.....	4,717,000	2,906,000	2,786,000	2,008,000	5,311,000
Pork.....	29,189,000	25,279,000	94,113,000	127,776,000	16,047,000
Other.....	6,330,000	3,870,000	42,494,000	28,985,000	2,155,000
Total.....	43,327,000	37,678,000	149,176,000	178,203,000	33,053,000
Cuba:					
Beef.....	37,822,000	22,655,000	42,271,000	39,800,000	24,347,000
Mutton.....	41,000	56,000	13,000	22,000	81,000
Pork.....	85,973,000	96,805,000	104,444,000	86,454,000	98,866,000
Other.....	4,525,000	4,862,000	6,438,000	6,898,000	7,812,000
Total.....	128,361,000	124,378,000	153,166,000	133,174,000	131,106,000
Germany:					
Beef.....	212,150,000				
Mutton.....	1,046,000				
Pork.....	265,666,000				
Other.....	80,886,000				
Total.....	559,748,000				
Italy:					
Beef.....	131,000	215,000	262,000	97,000	( <sup>2</sup> )
Pork.....	74,861,000	15,238,000	8,894,000	29,883,000	89,889,000
Other.....	29,627,000	143,075,000	272,426,000	259,664,000	401,992,000
Total.....	104,619,000	158,528,000	281,582,000	289,644,000	491,881,000
Netherlands:					
Beef and veal.....	256,296,000	187,097,000			
Mutton.....	76,000	10,000			
Pork.....	88,143,000	51,255,000			
Other.....	15,349,000	8,698,000			
Total.....	359,864,000	247,060,000			
Norway:					
Beef.....	20,203,000	26,600,000	30,797,000	26,316,000	
Pork.....	9,751,000	11,348,000	18,523,000	16,341,000	
Other.....	12,460,000	5,048,000	7,222,000	27,116,000	
Total.....	42,414,000	42,996,000	56,542,000	69,773,000	
Russia: <sup>1</sup>					
Beef.....	2,216,000	78,000	347,000		
Other.....	128,682,000	32,634,000	3,582,000		
Total.....	130,898,000	32,712,000	3,929,000		
Spain:					
Beef.....	966,000	80,000	160,000	167,000	81,000
Pork.....	553,000	1,760,000	5,881,000	1,050,000	56,000
Other.....	36,455,000	29,477,000	24,458,000	24,917,000	12,807,000
Total.....	37,974,000	31,317,000	30,499,000	26,134,000	12,944,000

<sup>1</sup> 1916 figures are for over European frontier only.

<sup>2</sup> Less than 500 pounds.

TABLE 221.—Meat and meat products: International trade, calendar years 1911-1918—Continued.

## IMPORTS—Continued.

Exporting country and classification.	Average, 1911-1913.	1915	1916	1917	1918
<b>Sweden:</b>	<i>Pounds.</i>	<i>Pounds.</i>	<i>Pounds.</i>	<i>Pounds.</i>	<i>Pounds.</i>
Beef.....	12,912,000	19,202,000	15,878,000	1,621,000	.....
Mutton.....	1,218,000	116,000	26,000	3,000	.....
Pork.....	6,736,000	9,832,000	6,572,000	14,683,000	.....
Other.....	3,349,000	6,788,000	2,541,000	1,392,000	.....
Total.....	24,215,000	35,938,000	25,017,000	17,699,000	.....
<b>Switzerland:</b>					
Beef.....	9,052,000	5,990,000	6,354,000	4,326,000	5,978,000
Pork.....	21,976,000	8,765,000	6,646,000	8,928,000	14,379,000
Other.....	25,298,000	5,532,000	5,251,000	4,418,000	3,212,000
Total.....	56,326,000	20,287,000	18,251,000	17,672,000	23,569,000
<b>United Kingdom:</b>					
Beef.....	1,413,965,000	1,669,573,000	1,471,188,000	1,180,013,000	1,296,341,000
Mutton.....	598,657,000	533,936,000	412,202,000	292,922,000	237,862,000
Pork.....	919,794,000	1,186,132,000	1,261,082,000	1,047,118,000	1,656,084,000
Other.....	124,530,000	138,403,000	113,993,000	110,292,000	110,267,000
Total.....	3,056,946,000	3,528,044,000	3,258,465,000	2,630,345,000	3,300,554,000
<b>United States:</b>					
Beef.....	17,668,000	120,308,000	40,421,000	27,628,000	30,291,000
Mutton.....	185,000	11,879,000	17,235,000	5,624,000	608,000
Pork.....	171,000	5,496,000	1,171,000	2,821,000	3,585,000
Other.....	696,000	98,000	4,000	13,000	5,000
Total.....	18,720,000	137,781,000	58,831,000	36,086,000	34,489,000
<b>Other countries:</b>					
Beef.....	68,773,000	.....	.....	.....	.....
Mutton.....	9,310,000	.....	.....	.....	.....
Pork.....	56,704,000	.....	.....	.....	.....
Other.....	27,412,000	.....	.....	.....	.....
Total.....	162,199,000	.....	.....	.....	.....
<b>All countries:</b>					
Beef.....	2,122,252,000	.....	.....	.....	.....
Mutton.....	615,250,000	.....	.....	.....	.....
Pork.....	1,601,190,000	.....	.....	.....	.....
Other.....	669,321,000	.....	.....	.....	.....
Total.....	5,008,013,000	.....	.....	.....	.....

HORSES AND MULES.

TABLE 222.—Horses and mules: Number and value on farms in the United States, 1867-1920.

NOTE.—Figures in *italics* are census returns; figures in roman are estimates of the Department of Agriculture. Estimates of numbers are obtained by applying estimated percentages of increase or decrease to the published numbers of the preceding year, except that a revised base is used for applying percentage estimates whenever new census data are available. It should also be observed that the census of 1910, giving numbers as of Apr. 15, is not strictly comparable with former censuses, which related to numbers June 1.

Jan. 1—	Horses.			Mules.		
	Number.	Price per head Jan. 1.	Farm value Jan. 1.	Number.	Price per head Jan. 1.	Farm value Jan. 1.
1867.....	5,401,000	\$59.05	\$318,924,000	822,000	\$66.94	\$55,048,000
1868.....	5,757,000	54.27	312,416,000	856,000	56.04	47,954,000
1869.....	6,333,000	62.57	396,222,000	922,000	79.23	73,027,000
1870.....	8,249,000	67.43	556,251,000	1,180,000	90.42	106,654,000
1870, census, June 1.....	<i>7,146,870</i>			<i>1,125,415</i>		
1871.....	8,702,000	71.14	619,039,000	1,242,000	91.98	114,272,000
1872.....	8,991,000	67.41	606,111,000	1,276,000	87.14	111,222,000
1873.....	9,222,000	66.39	612,273,000	1,310,000	85.15	111,546,000
1874.....	9,334,000	65.15	608,073,000	1,339,000	81.35	108,953,000
1875.....	9,504,000	61.10	580,708,000	1,394,000	71.89	100,197,000
1876.....	9,935,000	57.29	557,747,000	1,414,000	66.46	94,001,000
1877.....	10,155,000	55.83	567,017,000	1,444,000	64.07	92,482,000
1878.....	10,330,000	56.63	584,999,000	1,638,000	62.03	101,579,000
1879.....	10,939,000	52.36	572,712,000	1,713,000	56.00	95,942,000
1880.....	11,202,000	54.75	613,297,000	1,730,000	61.26	105,948,000
1880, census, June 1.....	<i>10,357,488</i>			<i>1,812,808</i>		
1881.....	11,430,000	58.44	667,954,000	1,721,000	69.79	120,096,000
1882.....	10,522,000	58.53	615,825,000	1,835,000	71.35	130,945,000
1883.....	10,838,000	70.59	765,041,000	1,871,000	79.49	148,732,000
1884.....	11,170,000	74.64	833,734,000	1,914,000	84.22	161,215,000
1885.....	11,565,000	73.70	852,283,000	1,973,000	82.38	162,497,000
1886.....	12,078,000	71.27	860,823,000	2,053,000	79.60	163,381,000
1887.....	12,497,000	72.15	901,686,000	2,117,000	78.91	167,058,000
1888.....	13,173,000	71.82	946,096,000	2,192,000	79.78	174,854,000
1889.....	13,663,000	71.89	982,195,000	2,258,000	79.49	179,444,000
1890.....	14,214,000	68.84	978,517,000	2,331,000	78.25	182,394,000
1890, census, June 1.....	<i>14,969,467</i>			<i>2,295,532</i>		
1891.....	14,057,000	67.00	941,823,000	2,297,000	77.88	178,847,000
1892.....	15,498,000	65.01	1,007,594,000	2,315,000	75.55	174,882,000
1893.....	16,207,000	61.22	992,225,000	2,331,000	70.68	164,764,000
1894.....	16,081,000	47.83	769,225,000	2,352,000	62.17	146,233,000
1895.....	15,893,000	36.29	576,731,000	2,333,000	47.55	110,928,000
1896.....	15,124,000	33.07	500,140,000	2,279,000	45.29	103,204,000
1897.....	14,365,000	31.51	452,649,000	2,216,000	41.66	92,302,000
1898.....	13,961,000	34.26	478,362,000	2,190,000	43.88	96,110,000
1899.....	13,665,000	37.40	511,075,000	2,134,000	44.96	95,963,000
1900.....	13,538,000	44.61	603,969,000	2,086,000	53.55	111,717,000
1900, census, June 1.....	<i>18,267,020</i>			<i>3,264,615</i>		
1901 <sup>1</sup> .....	16,745,000	52.86	885,200,000	2,864,000	63.97	183,232,000
1902.....	16,531,000	58.61	968,935,000	2,757,000	67.61	186,412,000
1903.....	16,557,000	62.25	1,030,706,000	2,728,000	72.49	197,753,000
1904.....	16,736,000	67.93	1,136,940,000	2,758,000	78.88	217,533,000
1905.....	17,058,000	70.37	1,200,310,000	2,889,000	87.18	251,840,000
1906.....	18,719,000	80.72	1,510,890,000	3,404,000	98.31	334,681,000
1907.....	19,747,000	93.51	1,846,578,000	3,817,000	112.16	428,064,000
1908.....	19,992,000	93.41	1,867,530,000	3,869,000	107.76	416,939,000
1909.....	20,640,000	95.64	1,974,052,000	4,053,000	107.84	437,082,000
1910.....	21,040,000			4,123,000		
1910, census, Apr. 15.....	<i>19,833,113</i>	108.03	2,142,524,000	<i>4,209,769</i>	120.20	506,049,000
1911 <sup>1</sup> .....	20,277,000	111.46	2,259,981,000	4,323,000	125.92	544,359,000
1912.....	20,509,000	105.94	2,172,694,000	4,362,000	120.51	525,657,000
1913.....	20,567,000	110.77	2,278,222,000	4,386,000	124.31	545,245,000
1914.....	20,962,000	109.32	2,291,638,000	4,449,000	123.85	551,017,000
1915.....	21,195,000	103.33	2,190,102,000	4,479,000	112.36	503,271,000
1916.....	21,159,000	101.60	2,149,786,000	4,593,000	113.83	522,834,000
1917.....	21,210,000	102.89	2,182,307,000	4,723,000	118.15	558,006,000
1918.....	21,555,000	104.24	2,246,970,000	4,873,000	128.81	627,679,000
1919.....	21,482,000	98.45	2,114,897,000	4,954,000	135.83	672,922,000
1920.....	21,109,000	94.39	1,992,542,000	4,995,000	147.10	734,779,000

<sup>1</sup> Estimates of numbers revised, based on census data.

## HORSES AND MULES—Continued.

TABLE 223.—Horses and mules: Number and value on farms, Jan. 1, 1919 and 1920, by States.

State.	Horses.						Mules.					
	Number (thousands) Jan. 1—		Average price per head Jan. 1—		Farm value (thousands of dollars) Jan. 1—		Number (thousands) Jan. 1—		Average price per head Jan. 1—		Farm value (thousands of dollars) Jan. 1—	
	1920	1919	1920	1919	1920	1919	1920	1919	1920	1919	1920	1919
Maine.....	107	108	\$154.00	\$154.00	\$16,478	\$16,632						
New Hampshire.....	40	41	144.00	145.00	5,760	5,945						
Vermont.....	85	86	141.00	139.00	11,985	11,954						
Massachusetts.....	52	54	155.00	157.00	8,060	8,478						
Rhode Island.....	8	8	160.00	159.00	1,280	1,272						
Connecticut.....	43	44	165.00	164.00	7,095	7,216						
New York.....	560	565	141.00	139.00	78,960	78,535	7	7	\$148.00	\$139.00	\$1,036	\$973
New Jersey.....	88	89	150.00	143.00	13,200	12,727	4	4	171.00	167.00	684	668
Pennsylvania.....	560	570	123.00	124.00	68,880	70,680	46	46	141.00	129.00	6,486	5,934
Delaware.....	34	35	83.00	92.00	2,822	3,220	6	6	111.00	122.00	666	732
Maryland.....	168	171	102.00	104.00	17,136	17,784	25	25	134.00	133.00	3,350	3,325
Virginia.....	362	369	108.00	109.00	39,096	40,221	65	66	136.00	138.00	8,840	9,108
West Virginia.....	192	194	104.00	101.00	19,968	19,594	12	12	121.00	115.00	1,452	1,380
North Carolina.....	183	181	153.00	146.00	27,999	26,426	236	225	190.00	176.00	44,840	39,600
South Carolina.....	80	80	180.00	180.00	14,400	14,400	206	200	231.00	206.00	47,586	41,200
Georgia.....	132	131	159.00	156.00	20,988	20,436	351	344	216.00	200.00	75,816	68,800
Florida.....	60	60	140.00	129.00	8,400	7,740	40	39	196.00	177.00	7,840	6,903
Ohio.....	873	891	109.00	107.00	95,157	95,337	28	28	120.00	117.00	3,360	3,276
Indiana.....	821	829	101.00	103.00	82,921	85,387	93	94	128.00	125.00	11,904	11,750
Illinois.....	1,422	1,467	94.00	100.00	133,668	146,700	147	147	125.00	125.00	18,375	18,375
Michigan.....	640	660	95.00	105.00	60,800	69,300	4	4	99.00	106.00	396	424
Wisconsin.....	680	694	109.00	109.00	74,120	75,646	3	3	112.00	111.00	336	333
Minnesota.....	940	950	91.00	98.00	85,540	93,100	6	6	99.00	110.00	594	660
Iowa.....	1,505	1,536	89.00	95.00	133,945	145,920	71	70	121.00	113.00	8,591	7,910
Missouri.....	1,040	1,040	83.00	92.00	86,320	95,680	378	374	120.00	116.00	45,360	43,384
North Dakota.....	825	850	81.00	93.00	66,825	79,050	9	9	98.00	107.00	882	963
South Dakota.....	819	827	71.00	80.00	58,149	66,160	15	16	94.00	99.00	1,410	1,584
Nebraska.....	1,018	1,049	75.00	87.00	76,350	91,263	106	109	109.00	109.00	11,554	11,881
Kansas.....	1,153	1,153	79.00	94.00	91,087	108,382	260	260	117.00	114.00	30,420	29,640
Kentucky.....	429	439	101.00	104.00	43,329	45,656	231	231	126.00	127.00	29,106	29,337
Tennessee.....	353	357	113.00	116.00	39,889	41,412	278	278	139.00	140.00	38,642	38,920
Alabama.....	158	155	128.00	128.00	20,224	19,840	316	304	171.00	157.00	54,036	47,728
Mississippi.....	261	258	113.00	113.00	29,493	29,154	322	316	152.00	139.00	48,944	43,924
Louisiana.....	215	215	107.00	97.00	23,005	20,855	166	164	164.00	145.00	27,224	23,780
Texas.....	1,199	1,164	96.00	78.00	115,104	90,792	784	792	140.00	115.00	109,760	91,080
Oklahoma.....	729	744	83.00	83.00	60,507	61,752	288	288	120.00	110.00	34,560	31,680
Arkansas.....	266	269	97.00	93.00	25,802	25,017	324	315	132.00	123.00	42,768	38,745
Montana.....	518	575	60.00	84.00	31,080	48,300	5	5	80.00	99.00	400	495
Wyoming.....	225	235	53.00	77.00	11,925	18,095	4	4	90.00	106.00	360	424
Colorado.....	427	419	79.00	91.00	33,733	38,129	31	31	101.00	107.00	3,131	3,317
New Mexico.....	232	242	68.00	62.00	15,776	15,004	20	20	104.00	92.00	2,080	1,840
Arizona.....	132	136	70.00	71.00	9,240	9,656	10	10	106.00	112.00	1,060	1,120
Utah.....	145	148	78.00	83.00	11,310	12,284	2	2	73.00	78.00	146	156
Nevada.....	75	77	60.00	62.00	4,500	4,774	3	3	64.00	72.00	192	216
Idaho.....	270	276	77.00	89.00	20,790	24,564	4	4	91.00	98.00	364	392
Washington.....	303	303	92.00	92.00	27,876	27,876	20	20	106.00	108.00	2,120	2,160
Oregon.....	282	303	85.00	89.00	23,970	26,967	10	10	91.00	93.00	910	930
California.....	400	435	94.00	91.00	37,600	39,585	59	63	122.00	125.00	7,198	7,875
United States..	21,109	21,482	94.39	98.45	1,992,542	2,114,897	4,995	4,954	147.10	135.83	734,779	672,922





## HORSES AND MULES—Continued.

TABLE 226.—Average price per head for horses on the Chicago market, 1902-1919—Con.

Year and month.	Drafters.	Carriage teams.	Drivers.	General.	Bussers, trammers.	Cavalry horses.	Southern chunks.
1919.		(1)			(2)		
January.....							
February.....							
March.....							
April.....	\$250.00	\$202.00		\$152.00	\$162.00		\$105.00
May.....	218.00	170.00		130.00	135.00		75.00
June.....	200.00	172.00		120.00	118.00		65.00
July.....	218.00	170.00		118.00	118.00		65.00
August.....	205.00	158.00		105.00	112.00		65.00
September.....	230.00	158.00		105.00	112.00		65.00
October.....	250.00	158.00		105.00	112.00		75.00
November.....	250.00	158.00		105.00	112.00		75.00
December.....	250.00	158.00		105.00	112.00		65.00
Year 1919.....							

<sup>1</sup> Expressers for 1919.<sup>2</sup> Farm chunks for 1919.

TABLE 227.—Number of horses and mules received at principal live-stock markets.

[From reports of stockyard companies.]

Year and month.	Horses.		Horses and mules.					St. Louis National Stock Yards, Ill.	Total 8 cities.
	Chicago. <sup>1</sup>	St. Paul.	Denver.	Fort Worth.	Kansas City.	Omaha.	St. Joseph.		
1900.....	99,010	26,778	22,691	.....	103,308	59,645	13,497	144,921	469,850
1901.....	109,353	15,123	16,545	.....	96,657	36,391	22,521	128,880	425,470
1902.....	102,100	8,162	24,428	4,872	76,844	42,079	19,909	109,295	387,689
1903.....	100,603	7,823	19,040	10,094	67,274	52,829	20,483	128,615	406,761
1904.....	105,949	6,438	13,437	17,895	67,562	46,845	28,704	181,341	468,171
1905.....	127,250	5,561	16,046	18,033	65,582	45,422	31,565	178,257	487,716
1906.....	126,979	9,299	16,571	21,303	69,629	42,269	28,480	166,393	480,923
1907.....	102,055	14,557	11,059	18,507	62,341	44,020	26,894	117,379	396,812
1908.....	92,138	7,125	11,158	12,435	56,335	39,998	22,875	109,393	351,457
1909.....	91,411	5,632	15,348	20,732	67,796	31,711	23,132	122,471	378,233
1910.....	83,439	5,482	15,554	34,445	69,628	29,734	27,583	130,271	396,136
1911.....	104,545	7,709	18,022	37,361	84,861	31,771	42,023	170,379	496,671
1912.....	92,977	5,314	14,918	49,025	73,445	32,520	38,661	163,973	470,833
1913.....	90,615	5,203	16,274	56,724	82,110	31,580	32,418	156,825	471,749
1914.....	106,282	5,683	16,957	47,712	87,155	30,688	25,424	148,128	468,029
1915.....	165,253	10,091	71,870	53,640	102,153	41,679	41,254	270,612	756,552
1916.....	205,449	11,777	52,800	79,209	123,141	27,486	27,206	266,818	793,886
1917.....	107,311	9,959	19,758	115,233	127,823	32,781	33,584	279,837	726,286
1918.									
January.....	6,002	1,160	2,341	9,821	14,020	2,150	4,445	33,746	73,685
February.....	5,997	504	961	7,239	11,688	1,751	5,877	33,071	67,088
March.....	8,086	573	1,840	6,020	11,544	2,261	5,154	28,010	63,488
April.....	5,620	271	750	3,696	1,971	658	1,293	7,120	21,379
May.....	6,594	422	835	1,599	1,811	534	971	5,201	17,967
June.....	10,727	990	655	585	1,977	966	705	6,035	22,640
July.....	9,691	863	730	2,760	2,201	3,242	1,974	8,943	30,404
August.....	8,599	456	1,625	5,887	5,387	3,203	4,039	17,517	46,713
September.....	6,101	339	1,590	15,088	9,919	3,764	5,317	31,522	73,640
October.....	8,382	544	1,571	13,680	12,401	2,181	4,542	30,183	73,484
November.....	9,267	280	1,093	7,883	7,644	1,064	2,972	24,819	55,022
December.....	2,754	139	608	4,623	4,065	438	1,971	15,584	30,182
Total, 1918.....	87,820	6,541	14,599	78,881	84,628	22,212	39,260	241,751	575,692
1919.									
January.....	3,855	194	1,379	6,329	7,858	719	4,611	25,471	50,416
February.....	3,738	257	1,396	5,367	7,274	700	3,944	20,316	42,992
March.....	5,174	449	1,459	3,897	5,727	948	2,673	15,395	35,722
April.....	4,246	281	850	3,031	4,854	619	1,407	11,066	26,354
May.....	3,720	147	932	1,930	3,261	393	342	6,697	17,422
June.....	3,636	878	604	1,916	2,686	2,485	1,984	11,328	25,517
July.....	3,048	1,071	1,420	1,208	4,062	3,828	4,030	15,535	34,202
August.....	2,787	1,539	1,399	4,575	7,923	4,354	3,958	22,487	49,022
September.....	4,504	2,822	1,996	6,283	11,323	6,087	5,940	38,418	77,373
October.....	2,949	1,300	3,570	7,916	9,349	2,811	6,649	33,433	67,977
November.....	4,732	1,728	4,370	11,144	11,656	1,497	4,620	31,204	70,951
December.....	45,762	11,228	22,936	60,363	82,852	25,201	43,380	250,211	542,033
Total, 1919.....	3,373	562	3,561	6,767	6,879	760	3,222	18,961	40,085

<sup>1</sup> From Reports of the Bureau of Markets for 1919.

HORSES AND MULES—Continued.

TABLE 228.—Horses and mules: Imports, exports, and prices, 1893-1919.

Year ending June 30—	Imports of horses.			Exports of horses.			Exports of mules.		
	Number.	Value.	Average import price.	Number.	Value.	Average export price.	Number.	Value.	Average export price.
1893.....	15,451	\$2,388,267	\$154.57	2,967	\$718,607	\$242.20	1,634	\$210,278	\$128.69
1894.....	6,166	1,319,572	214.01	5,246	1,108,995	211.40	2,063	240,961	116.80
1895.....	13,098	1,055,191	80.56	13,984	2,209,298	157.99	2,515	186,452	74.14
1896.....	9,991	662,591	66.32	25,126	3,530,703	140.52	5,918	406,161	68.63
1897.....	6,998	464,808	66.42	39,532	4,769,265	120.64	7,473	545,331	72.97
1898.....	3,085	414,899	134.49	51,150	6,176,569	120.75	8,098	664,789	82.09
1899.....	3,042	551,050	181.15	45,778	5,444,342	118.93	6,755	516,908	76.52
1900.....	3,102	596,592	192.32	64,722	7,612,616	117.62	43,369	3,919,478	90.38
1901.....	3,785	985,738	260.43	82,250	8,873,845	107.89	34,405	3,210,267	93.30
1902.....	4,832	1,577,234	326.41	103,020	10,048,046	97.53	27,586	2,692,298	97.61
1903.....	4,999	1,536,296	307.32	34,007	3,152,159	92.69	4,294	521,725	121.47
1904.....	4,726	1,460,287	308.99	42,001	3,189,100	75.93	3,658	412,971	112.90
1905.....	5,180	1,591,083	307.16	34,822	3,175,259	91.19	5,826	645,464	110.79
1906.....	6,021	1,716,675	285.11	40,087	4,365,981	108.91	7,167	989,639	138.08
1907.....	6,080	1,978,105	325.35	33,882	4,359,957	131.99	6,781	850,901	125.48
1908.....	5,487	1,604,392	292.40	19,000	2,612,587	137.50	6,609	990,667	149.90
1909.....	7,084	2,007,276	283.35	21,616	3,386,617	156.67	3,432	472,017	137.53
1910.....	11,620	3,296,022	283.65	28,910	4,081,157	141.17	4,512	614,094	136.18
1911.....	9,593	2,692,074	280.63	25,145	3,845,253	152.92	6,585	1,070,051	162.50
1912.....	6,607	1,923,025	291.06	34,828	4,764,815	136.81	4,901	732,095	149.30
1913.....	10,008	2,125,875	212.42	28,707	3,960,102	137.95	4,744	733,795	154.68
1914.....	33,019	2,605,029	78.89	22,776	3,388,819	148.79	4,883	690,974	141.51
1915.....	12,652	977,380	77.25	289,340	64,046,534	221.35	65,788	12,726,143	193.44
1916.....	15,556	1,618,245	104.03	357,553	73,531,146	205.65	111,915	22,946,312	205.03
1917.....	12,584	1,888,303	150.06	278,674	59,525,329	213.60	136,689	27,800,854	203.39
1918.....	5,111	1,187,443	232.33	84,765	14,923,663	176.06	28,879	4,885,406	169.17
1919.....	4,003	750,264	187.43	27,975	5,206,251	186.10	12,452	2,333,929	187.43

CATTLE.

TABLE 229.—Cattle (live): Imports, exports, and prices, 1893-1919.

Year ending June 30—	Imports.			Exports.		
	Number.	Value.	Average import price.	Number.	Value.	Average export price.
1893.....	3,293	\$45,682	\$13.87	287,094	\$26,032,428	\$90.68
1894.....	1,592	18,704	11.75	359,278	33,461,922	93.14
1895.....	149,781	765,853	5.11	331,722	30,603,796	92.26
1896.....	217,826	1,509,856	6.93	372,461	34,560,672	92.79
1897.....	328,977	2,589,857	7.87	392,190	36,357,451	92.70
1898.....	291,589	2,913,223	9.99	439,255	37,827,500	86.12
1899.....	199,752	2,320,362	11.62	389,490	30,516,833	78.35
1900.....	181,006	2,257,694	12.47	397,286	30,635,153	77.11
1901.....	146,022	1,931,433	13.23	459,218	37,566,980	81.81
1902.....	96,027	1,608,722	16.75	392,884	29,902,212	76.11
1903.....	66,175	1,161,548	17.55	402,178	29,848,936	74.22
1904.....	16,056	310,737	19.35	593,409	42,256,291	71.21
1905.....	27,855	458,572	16.46	567,806	40,598,048	71.50
1906.....	29,019	548,430	18.90	584,239	42,081,170	72.03
1907.....	32,402	565,122	17.44	423,051	34,577,392	81.73
1908.....	92,356	1,507,310	16.32	349,210	29,339,134	84.02
1909.....	139,184	1,999,422	14.37	207,542	18,046,976	86.96
1910.....	195,938	2,999,824	15.37	139,430	12,200,154	87.50
1911.....	182,923	2,953,077	16.14	150,100	13,163,920	87.70
1912.....	318,372	4,805,574	15.09	105,506	8,870,075	84.07
1913.....	421,649	6,640,668	15.75	24,714	1,177,199	47.63
1914.....	868,368	18,696,718	21.53	18,376	647,288	35.22
1915.....	538,167	17,513,175	32.54	5,484	702,847	128.16
1916.....	439,185	15,187,593	34.58	21,666	2,383,765	110.02
1917.....	374,826	13,021,259	34.74	13,387	949,503	70.93
1918.....	293,719	17,852,176	60.78	18,213	1,247,800	68.51
1919.....	440,399	36,995,921	84.01	42,345	2,092,816	49.42

## CATTLE—Continued.

TABLE 230.—Cattle: Number and value on farms in the United States, 1867–1920.

NOTE.—Figures in *italics* are census returns; figures in roman are estimates of the Department of Agriculture. Estimates of numbers are obtained by applying estimated percentages of increase or decrease to the published numbers of the preceding year, except that a revised base is used for applying percentage estimates whenever new census data are available. It should also be observed that the census of 1910, giving numbers as of Apr. 15, is not strictly comparable with former censuses, which related to numbers June 1.

Jan. 1—	Milk cows.			Other cattle.		
	Number.	Price per head Jan. 1.	Farm value Jan. 1.	Number.	Price per head Jan. 1.	Farm value Jan. 1.
1867.....	8,349,000	\$28.74	\$239,947,000	11,731,000	\$15.79	\$185,254,000
1868.....	8,692,000	26.56	230,817,000	11,942,000	15.06	179,888,000
1869.....	9,248,000	29.15	269,610,000	12,185,000	18.73	228,183,000
1870.....	10,096,000	32.70	330,175,000	15,388,000	18.87	290,401,000
1870, census June 1.....	<i>8,935,332</i>			<i>13,566,005</i>		
1871.....	10,023,000	33.89	339,701,000	16,212,000	20.78	336,860,000
1872.....	10,304,000	29.45	303,438,000	16,390,000	18.12	296,932,000
1873.....	10,576,000	26.72	282,559,000	16,414,000	18.06	296,448,000
1874.....	10,705,000	25.63	274,326,000	16,218,000	17.55	284,706,000
1875.....	10,907,000	25.74	280,701,000	16,313,000	16.91	275,872,000
1876.....	11,085,000	25.61	283,879,000	16,785,000	17.00	285,387,000
1877.....	11,261,000	25.47	286,778,000	17,956,000	15.99	287,156,000
1878.....	11,300,000	25.74	290,898,000	19,223,000	16.72	321,346,000
1879.....	11,826,000	21.71	256,721,000	21,408,000	15.38	329,254,000
1880.....	12,027,000	23.27	279,899,000	21,231,000	16.10	341,761,000
1880, census June 1.....	<i>12,443,120</i>			<i>22,488,560</i>		
1881.....	12,369,000	23.95	296,277,000	20,939,000	17.33	362,862,000
1882.....	12,612,000	25.89	326,489,000	23,280,000	19.89	463,070,000
1883.....	13,126,000	30.21	396,575,000	28,046,000	21.81	611,549,000
1884.....	13,501,000	31.37	423,487,000	29,046,000	23.52	683,229,000
1885.....	13,905,000	29.70	412,903,000	29,867,000	23.25	694,383,000
1886.....	14,235,000	27.40	389,986,000	31,275,000	21.17	661,956,000
1887.....	14,522,000	26.08	378,790,000	33,512,000	19.79	663,138,000
1888.....	14,856,000	24.65	366,252,000	34,378,000	17.79	611,751,000
1889.....	15,299,000	23.94	366,226,000	35,032,000	17.05	597,237,000
1890.....	15,953,000	22.14	353,152,000	36,849,000	15.21	560,625,000
1890, census June 1.....	<i>16,511,950</i>			<i>33,734,128</i>		
1891.....	16,020,000	21.62	346,398,000	36,876,000	14.76	544,128,000
1892.....	16,416,000	21.40	351,378,000	37,051,000	15.16	570,749,000
1893.....	16,424,000	21.75	357,300,000	35,054,000	15.24	547,882,000
1894.....	16,487,000	21.77	358,999,000	36,608,000	14.66	536,790,000
1895.....	16,505,000	21.97	362,602,000	34,364,000	14.06	482,999,000
1896.....	16,138,000	22.55	363,956,000	32,085,000	15.86	508,928,000
1897.....	15,942,000	23.16	369,240,000	30,508,000	16.65	507,929,000
1898.....	15,841,000	27.45	434,814,000	29,264,000	20.92	612,297,000
1899.....	15,990,000	29.66	474,234,000	27,994,000	22.79	637,931,000
1900.....	16,292,000	31.60	514,812,000	27,610,000	24.97	689,486,000
1900, census June 1.....	<i>17,135,633</i>			<i>50,585,777</i>		
1901 <sup>1</sup> .....	16,834,000	30.00	505,093,000	45,500,000	19.93	906,644,000
1902.....	16,697,000	29.23	488,130,000	44,728,000	18.76	839,126,000
1903.....	17,105,000	30.21	516,712,000	44,659,000	18.45	824,055,000
1904.....	17,420,000	29.21	508,841,000	43,629,000	16.32	712,178,000
1905.....	17,572,000	27.44	482,272,000	43,669,000	15.15	661,571,000
1906.....	19,794,000	29.44	582,789,000	47,068,000	15.85	746,172,000
1907.....	20,968,000	31.00	645,497,000	51,566,000	17.10	881,557,000
1908.....	21,194,000	30.67	650,057,000	50,073,000	16.89	845,938,000
1909.....	21,720,000	32.36	702,945,000	49,379,000	17.49	863,754,000
1910.....	21,801,000			47,279,000		
1910, census Apr. 15.....	<i>20,625,432</i>	35.29	727,802,000	<i>41,178,434</i>	19.07	785,261,000
1911 <sup>1</sup> .....	20,823,000	39.97	832,209,000	39,679,000	20.54	815,184,000
1912.....	20,699,000	39.39	815,414,000	37,260,000	21.20	790,064,000
1913.....	20,497,000	45.02	922,783,000	36,030,000	26.36	949,645,000
1914.....	20,737,000	53.94	1,118,487,000	35,855,000	31.13	1,116,333,000
1915.....	21,262,000	55.33	1,176,338,000	37,067,000	33.38	1,237,376,000
1916.....	22,108,000	53.92	1,191,955,000	39,812,000	33.53	1,334,928,000
1917.....	22,894,000	59.63	1,365,251,000	41,689,000	35.88	1,497,621,000
1918.....	23,310,000	70.54	1,644,231,000	44,112,000	40.88	1,803,482,000
1919.....	23,475,000	78.20	1,835,770,000	45,085,000	44.22	1,993,442,000
1920.....	23,747,000	85.13	2,021,681,000	44,485,000	43.15	1,919,445,000

<sup>1</sup> Estimates of numbers revised, based on census data.

CATTLE—Continued.

TABLE 231.—Cattle: Number and value on farms Jan. 1, 1919 and 1920, by States.

State.	Milk cows.						Other cattle.					
	Number (thousands) Jan. 1—		Average price per head Jan. 1—		Farm value (thousands of dollars) Jan. 1—		Number (thousands) Jan. 1—		Average price per head Jan. 1—		Farm value (thousands of dollars) Jan. 1—	
	1920	1919	1920	1919	1920	1919	1920	1919	1920	1919	1920	1919
Maine.....	179	175	\$79.00	\$70.50	\$14,141	\$12,338	143	142	\$35.90	\$36.10	\$5,134	\$5,126
New Hampshire....	103	105	85.00	80.00	8,858	8,400	70	70	41.70	39.80	2,919	2,786
Vermont.....	278	281	89.00	72.00	24,742	20,232	190	190	37.20	31.20	7,068	5,928
Massachusetts.....	159	160	105.00	94.00	16,695	15,040	102	100	44.80	36.30	4,570	3,630
Rhode Island.....	20	20	110.00	101.00	2,200	2,020	14	13	46.90	40.10	657	521
Connecticut.....	118	115	105.00	94.00	12,390	10,810	80	76	47.70	41.90	3,816	3,184
New York.....	1,493	1,478	107.00	89.00	159,751	131,542	909	900	48.30	41.00	43,905	36,900
New Jersey.....	153	150	128.00	100.00	19,584	15,000	77	74	57.00	51.30	4,389	3,796
Pennsylvania.....	970	960	98.00	85.00	95,060	81,600	727	720	46.00	40.70	33,442	29,304
Delaware.....	46	44	85.00	76.00	3,910	3,344	24	23	46.80	42.80	1,123	984
Maryland.....	180	177	89.00	80.00	16,020	14,160	138	135	50.40	45.60	6,955	6,156
Virginia.....	437	424	76.00	69.00	33,212	29,256	578	567	49.20	46.40	28,438	26,309
West Virginia.....	250	243	76.00	71.00	19,000	17,253	384	366	51.70	50.30	19,853	18,410
North Carolina.....	328	315	78.00	69.00	25,584	21,735	394	379	35.30	31.90	13,908	12,090
South Carolina.....	211	203	85.00	78.00	17,935	15,834	249	244	36.50	34.40	9,088	8,394
Georgia.....	461	452	65.00	65.00	29,965	29,380	771	763	27.20	27.30	20,971	20,830
Florida.....	156	149	72.00	61.00	11,232	9,089	945	936	27.30	24.80	25,798	23,213
Ohio.....	1,061	1,030	92.00	83.50	97,612	86,005	1,113	1,102	48.70	47.30	54,203	52,125
Indiana.....	724	713	88.00	85.00	63,712	60,605	764	780	51.60	52.40	39,422	40,872
Illinois.....	1,060	1,000	96.00	90.00	101,760	95,400	1,290	1,340	54.60	54.00	70,434	72,360
Michigan.....	873	848	96.00	83.00	83,808	70,384	773	750	42.80	38.90	33,084	29,175
Wisconsin.....	1,846	1,792	97.00	82.00	179,062	146,944	1,493	1,436	40.20	37.00	60,019	53,132
Minnesota.....	1,395	1,368	82.00	78.00	114,390	106,704	1,730	1,632	32.60	33.50	56,398	54,672
Iowa.....	1,353	1,381	88.00	86.00	119,064	118,766	2,775	2,861	49.00	52.60	135,975	150,489
Missouri.....	919	919	79.00	74.00	72,601	68,006	1,746	1,782	48.90	49.40	85,379	88,031
North Dakota.....	464	451	77.00	80.00	35,728	36,080	617	636	41.40	47.60	25,544	30,274
South Dakota.....	561	561	75.00	82.00	42,075	46,002	1,526	1,496	44.30	53.90	67,602	80,634
Nebraska.....	601	620	83.00	85.00	49,883	52,700	2,911	2,940	45.30	49.90	131,868	146,706
Kansas.....	935	964	81.00	81.00	75,735	78,084	2,161	2,401	48.00	52.70	103,728	126,533
Kentucky.....	457	452	73.00	72.00	33,361	32,544	580	610	41.20	42.50	23,896	25,925
Tennessee.....	384	380	70.00	66.00	26,880	25,080	593	587	32.80	34.30	19,450	20,134
Alabama.....	502	494	57.00	58.00	28,614	28,652	842	851	22.90	24.30	19,282	20,679
Mississippi.....	571	549	62.00	60.00	35,402	32,940	716	695	23.50	26.70	16,826	18,556
Louisiana.....	378	363	67.00	58.00	25,326	21,054	725	690	29.30	26.80	21,242	18,492
Texas.....	1,138	1,094	77.00	63.00	87,626	68,922	4,458	4,287	41.80	36.80	186,344	157,762
Oklahoma.....	550	561	68.00	68.00	37,400	38,148	1,300	1,444	41.70	44.20	54,210	63,825
Arkansas.....	452	443	56.00	59.00	25,312	26,137	691	678	24.40	24.70	16,860	16,747
Montana.....	180	197	83.00	87.00	14,940	17,139	936	1,170	50.60	58.90	47,362	68,913
Wyoming.....	82	80	93.00	95.00	7,626	7,600	787	1,100	50.50	61.80	39,744	67,980
Colorado.....	272	264	87.00	88.00	23,664	23,232	1,355	1,425	48.10	54.40	65,176	77,520
New Mexico.....	87	84	83.00	75.00	7,221	6,300	1,378	1,325	45.50	42.90	62,699	56,842
Arizona.....	57	72	95.00	90.00	5,415	6,480	1,200	1,100	44.00	43.40	52,800	47,740
Utah.....	109	106	78.00	82.00	8,502	8,692	518	503	39.30	48.10	20,357	24,194
Nevada.....	35	31	88.00	94.00	3,080	2,914	535	569	45.00	47.00	24,075	26,743
Idaho.....	136	136	85.00	82.00	11,560	11,152	537	537	44.10	48.90	23,682	26,259
Washington.....	228	228	88.00	75.00	20,064	17,100	298	307	43.80	37.60	13,052	11,543
Oregon.....	224	222	83.00	66.00	18,592	14,652	708	703	46.20	44.80	32,710	31,494
California.....	571	561	97.00	79.00	55,387	44,319	1,634	1,650	51.40	48.20	83,988	79,530
United States.....	23,747	23,475	85.13	78.20	2,021,681	1,835,770	44,485	45,085	43.15	44.22	1,919,445	1,993,442

## CATTLE—Continued.

TABLE 232.—Cattle: Wholesale price per 100 pounds, 1913-1919.

Date.	Chicago.			Cincinnati.			St. Louis.			Kansas City.			Omaha.		
	Inferior to prime.			Heavy to medium butcher steers.			Good to choice native steers.			Common to prime.			Native heaves.		
	Low.	High.	Average.	Low.	High.	Average.	Low.	High.	Average.	Low.	High.	Average.	Low.	High.	Average.
1913.															
January-June.....	\$5.65	\$9.85	\$7.81	\$4.65	\$7.65	\$5.92	\$8.00	\$9.25	\$9.05	\$4.75	\$9.00	.....	\$7.00	\$9.50	\$8.22
July-December.....	5.00	10.25	8.14	4.50	7.00	6.02	8.50	10.00	9.07	4.50	10.00	.....	7.70	9.25	8.64
1914.															
January-June.....	6.60	9.75	8.24	5.35	7.25	6.16	8.65	9.50	9.02	5.20	9.40	.....	6.50	10.50	8.23
July-December.....	5.40	11.75	8.99	4.65	7.25	5.27	9.30	11.10	10.24	4.50	11.35	.....	6.00	10.75	9.04
1915.															
January-June.....	5.30	10.15	7.96	4.85	7.00	5.90	7.00	10.00	8.06	6.00	9.75	\$7.51	6.50	9.35	8.05
July-December.....	5.75	11.50	8.44	4.00	7.00	5.32	8.60	10.50	9.56	5.50	10.35	8.21	8.90	10.10	9.05
1916.															
January-June.....	6.90	11.50	9.04	5.25	9.50	6.96	6.50	10.50	8.20	6.90	11.50	8.84	7.20	11.00	8.97
July-December.....	6.50	13.25	9.43	5.50	9.00	6.79	8.00	11.50	9.59	6.00	12.00	9.51	8.25	11.50	9.88
1917.															
January-June.....	5.75	13.90	10.16	6.00	12.85	9.14	10.00	12.25	10.86	6.50	13.75	9.95	10.00	13.85	11.85
July-December.....	6.15	17.90	11.42	5.00	14.50	9.62	10.00	16.50	13.10	9.25	17.00	13.21	11.50	17.00	14.27
1918.															
January-June.....	8.25	18.60	13.59	6.50	17.00	11.17	10.50	16.00	13.05	7.75	18.25	12.08	10.00	18.25	14.36
July-December.....	15.00	20.50	17.90	6.00	17.00	11.62	9.00	20.50	14.27	13.00	19.60	15.92	14.75	19.00	17.00
1919.															
January.....	10.00	20.35	15.08	6.50	17.00	11.80	13.50	15.00	14.38	10.25	19.50	15.09	9.00	18.50	15.05
February.....	10.00	20.25	15.45	7.00	17.25	12.03	14.00	15.00	14.50	13.00	18.50	15.75	12.75	18.25	15.75
March.....	11.25	20.40	16.49	7.00	16.50	11.94	14.00	15.00	14.50	11.00	18.50	14.96	13.50	18.75	16.24
April.....	14.25	20.40	17.47	7.50	16.25	11.94	14.00	15.00	14.50	11.00	19.50	15.10	13.00	18.50	15.82
May.....	13.50	20.25	16.89	7.50	16.25	11.75	13.75	15.00	14.50	10.50	19.00	14.60	10.50	18.35	14.37
June.....	12.75	17.50	14.73	7.00	14.00	10.50	13.75	17.75	14.78	10.50	17.50	13.40	10.50	15.75	12.76
January-June.....	10.00	20.40	16.02	6.50	17.25	11.66	13.50	17.75	14.53	10.25	19.50	14.82	9.00	18.75	15.00
July.....	11.75	18.40	15.43	6.50	17.00	11.80	13.50	17.00	15.54	10.00	18.50	13.33	10.50	18.00	14.56
August.....	11.50	19.25	15.84	7.00	17.25	12.03	15.50	16.50	15.75	8.50	19.00	14.40	10.50	18.85	13.31
September.....	12.25	18.00	15.29	5.50	14.00	9.91	14.75	16.00	15.31	8.00	18.75	13.43	11.00	18.00	13.83
October.....	13.00	19.40	16.46	6.00	14.00	9.85	14.75	16.00	15.46	9.00	18.40	13.62	10.00	17.50	13.24
November.....	11.50	20.50	16.98	6.00	14.65	10.08	15.75	19.25	14.46	8.75	18.25	13.46	10.00	17.50	13.24
December.....	11.25	21.50	15.86	6.00	16.00	10.85	15.75	19.25	14.46	8.75	18.00	12.65	8.00	16.50	12.28
July-December.....	11.25	21.50	15.97	5.50	17.25	10.75	13.50	19.25	15.16	8.00	19.00	13.48	8.00	18.85	12.56

TABLE 233.—Beef cattle: Farm price per 100 pounds, 15th of month, 1910-1919.

Date.	1919	1918	1917	1916	1915	1914	1913	1912	1911	1910	Average.
Jan. 15....	\$9.65	\$8.33	\$6.86	\$5.85	\$5.99	\$6.04	\$5.40	\$4.46	\$4.58	\$4.71	\$6.19
Feb. 15....	10.02	8.55	7.36	5.99	5.93	6.16	5.55	4.61	4.57	4.64	6.34
Mar. 15....	10.34	8.85	7.91	6.37	5.92	6.28	5.88	4.75	4.66	4.87	6.58
Apr. 15....	10.81	9.73	8.57	6.66	5.96	6.29	6.08	5.15	4.67	5.31	6.92
May 15....	10.84	10.38	8.70	6.73	6.13	6.33	6.01	5.36	4.59	5.23	7.03
June 15....	10.20	10.40	8.65	6.91	6.20	6.32	6.02	5.23	4.43	5.20	6.96
July 15....	9.95	10.07	8.30	6.78	6.07	6.38	5.98	5.17	4.28	4.84	6.78
Aug. 15....	9.82	9.71	8.17	6.51	6.18	6.47	5.91	5.37	4.39	4.64	6.72
Sept. 15....	9.02	9.63	8.40	6.55	6.06	6.38	5.92	5.35	4.43	4.65	6.64
Oct. 15....	8.65	9.33	8.35	6.37	6.04	6.23	6.05	5.36	4.32	4.64	6.53
Nov. 15....	8.65	9.14	8.21	6.44	5.85	6.02	5.99	5.22	4.36	4.48	6.44
Dec. 15....	8.63	9.28	8.24	6.56	5.75	6.01	5.96	5.33	4.37	4.45	6.46

CATTLE—Continued.

TABLE 234.—Milk cows: Farm price per head, 15th of month, 1910–1919.

	1919	1918	1917	1916	1915	1914	1913	1912	1911	1910	Average.
Jan. 15....	\$86.10	\$76.54	\$63.92	\$57.79	\$58.47	\$57.99	\$49.51	\$42.89	\$44.70	\$41.18	\$57.91
Feb. 15....	86.15	78.36	65.93	57.99	57.99	59.09	51.42	43.40	44.48	40.35	58.52
Mar. 15....	88.15	80.71	68.46	59.51	58.00	59.23	54.02	44.09	45.42	41.75	59.93
Apr. 15....	90.91	82.45	72.09	60.68	57.78	59.60	55.34	45.14	44.81	42.22	61.10
May 15....	93.43	84.11	72.78	60.98	58.29	59.85	54.80	45.63	44.54	42.38	61.68
June 15....	93.84	84.74	72.87	61.63	58.59	59.82	55.20	45.84	43.86	43.46	61.98
July 15....	94.51	84.97	72.81	62.04	60.31	59.67	54.80	45.41	42.44	42.86	61.98
Aug. 15....	94.72	84.06	72.53	61.32	58.34	60.72	54.78	46.11	42.26	42.77	61.76
Sept. 15....	93.42	85.21	73.93	61.41	58.38	59.58	55.78	46.79	42.22	42.68	61.94
Oct. 15....	93.43	85.41	75.79	62.19	58.76	59.53	56.47	47.30	42.69	43.20	62.48
Nov. 15....	93.27	84.51	75.00	62.67	57.35	58.77	57.71	47.38	42.70	43.34	62.27
Dec. 15....	95.54	85.78	76.16	63.18	56.79	58.23	57.19	48.62	42.72	43.41	62.76

TABLE 235.—Veal calves: Farm price per 100 pounds, 15th of month, 1910–1919.

	1919	1918	1917	1916	1915	1914	1913	1912	1911	1910	Average.
Jan. 15....	\$12.39	\$11.16	\$9.15	\$7.67	\$7.66	\$7.89	\$7.06	\$6.06	\$6.50	\$6.41	\$8.19
Feb. 15....	12.18	11.17	9.88	7.87	7.62	7.90	7.23	6.07	6.38	6.28	8.26
Mar. 15....	12.65	11.33	9.94	8.11	7.50	7.92	7.49	6.11	6.48	6.59	8.41
Apr. 15....	12.78	11.71	10.49	8.00	7.31	7.68	7.38	6.22	5.96	6.54	8.41
May 15....	12.11	11.62	10.48	8.08	7.35	7.59	7.17	6.23	5.68	6.30	8.26
June 15....	12.40	11.88	10.60	8.39	7.53	7.69	7.53	6.33	5.72	6.57	8.46
July 15....	13.38	12.33	10.77	8.54	7.87	7.80	7.46	6.33	5.74	6.37	8.66
Aug. 15....	13.43	12.22	10.56	8.59	7.75	8.08	7.53	6.62	5.93	6.29	8.70
Sept. 15....	13.39	12.57	11.08	8.77	7.80	8.06	7.73	6.83	6.11	6.43	8.88
Oct. 15....	12.87	12.35	11.10	8.59	7.91	7.97	7.72	6.90	6.15	6.41	8.80
Nov. 15....	12.65	11.94	10.66	8.60	7.69	7.78	7.70	6.77	6.10	6.39	8.63
Dec. 15....	12.67	12.31	10.98	8.79	7.61	7.61	7.74	6.88	5.98	6.38	8.70

BUTTER AND EGGS.

TABLE 236.—Butter: Wholesale price per pound, 1913–1919.

[Creamery, extra.]

Date.	Chicago. <sup>1</sup>			Cincinnati.			Milwaukee.			New York.			Boston.		
	Low	High	Average.	Low	High	Average.	Low	High	Average.	Low	High	Average.	Low	High	Average.
1913.	Cts.	Cts.	Cts.	Cts.	Cts.	Cts.	Cts.	Cts.	Cts.	Cts.	Cts.	Cts.	Cts.	Cts.	Cts.
January–June.....	25	36	.....	31	40	.....	27	35	.....	26½	42	.....	28	36½	.....
July–December.....	24	36	.....	30	39½	.....	26	35½	.....	26	37½	.....	27	35	.....
1914.															
January–June.....	24	35½	.....	27½	39½	.....	23½	35½	.....	24½	50	.....	25	34½	.....
July–December.....	26	34	.....	30	38	.....	26	34	.....	26½	36½	.....	27½	33½	.....
1915.															
January–June.....	26	34	.....	29½	38	.....	25½	34	.....	24	36	.....	27	33½	.....
July–December.....	24	34	.....	28	38	.....	24	34	.....	25	36½	.....	26	32	.....
1916.															
January–June.....	27½	36½	.....	32	40	.....	28	36	.....	29	38	.....	29½	35½	.....
July–December.....	27½	42	.....	31½	46	.....	27½	42	.....	28½	42½	.....	29	39	.....
1917.															
January–June.....	36	46	.....	39	50	.....	36	46	.....	37½	46¼	.....	38	47	.....
July–December.....	36½	49	.....	39	53	.....	38½	48	.....	37½	51½	.....	39½	46	.....
1918.															
January–June.....	40	49½	44.4	44½	54	49.0	40	49	44.3	40½	54¼	47.1	42	49	44.3
July–December.....	42½	67½	54.0	46	71	57.2	42½	65½	53.6	44½	70	56.2	44½	67	55.4
1919.															
January.....	42½	68	60.2	56½	71	66.4	41	66	39.7	46	71	61.9	47	69	62.6
February.....	43½	55	49.2	47	56½	51.8	41	53½	47.7	47¼	57	52.0	48	55	50.5
March.....	55	65½	59.7	59	70	63.5	53	63½	57.7	55½	68½	61.8	55	69	62.3
April.....	59	63½	61.7	64½	67½	66.5	57½	64	60.8	61	67½	64.6	63	69	65.4
May.....	54½	58½	56.7	59½	65½	60.2	52	60	55.3	55	60	58.3	56½	61½	59.1
June.....	49½	53	51.1	52½	55	54.0	48½	55	50.3	51	55	52.4	52	56	53.2
Jan.–June.....	42½	68	56.4	47	71	60.4	41	66	51.9	46	71	58.5	47	69	58.8
July.....	48	53½	51.4	51½	55½	54.4	48	53½	51.3	49½	55½	53.0	50½	56	53.3
August.....	52	54½	53.4	56	57	56.8	52	55½	53.0	53½	57	55.3	54½	57½	56.0
September.....	54½	63½	56.9	57	59½	58.2	53½	63	55.9	57	63	58.9	57	61	.....
October.....	62½	66½	64.2	66	68½	67.0	59	66	63.4	64	70	67.5	62	67	64.5
November.....	65	71¼	69.0	68½	75	71.8	66	72	68.7	69½	73½	71.2	67	71	68.6
December.....	63	72	67.7	.....	.....	.....	.....	.....	.....	70	74	72.5	70	73½	72.7
July–Dec.....	48	72	60.4	.....	.....	.....	.....	.....	.....	49½	74	63.1	50½	73½	.....

<sup>1</sup> From reports of the Bureau of Markets for 1919.

## BUTTER AND EGGS—Continued.

TABLE 237.—Butter: Average price received by farmers on 1st of each month, by States 1919, and United States 1909-1918.

State and year.	Butter, cents per pound.											
	Jan.	Feb.	Mar.	Apr.	May.	June.	July.	Aug.	Sept.	Oct.	Nov.	Dec.
Maine.....	58	58	51	52	52	53	52	52	60	59	61	65
New Hampshire.....	61	59	54	59	64	61	58	60	61	61	66	65
Vermont.....	65	62	54	60	64	63	58	60	62	62	67	70
Massachusetts.....	62	62	56	64	71	61	59	58	59	62	65	70
Rhode Island.....	67	60	52	70	66	70	60	62	65	62	67	68
Connecticut.....	61	64	56	59	61	61	59	62	57	65	65	65
New York.....	64	60	51	58	61	60	58	57	60	60	65	68
New Jersey.....	64	60	53	60	63	62	64	60	63	63	69	72
Pennsylvania.....	62	57	48	54	60	57	53	55	56	60	64	68
Delaware.....	60	55	50	60	50	40	50	50	50	56	60	61
Maryland.....	56	53	49	49	51	51	46	49	51	51	54	58
Virginia.....	49	48	44	47	47	44	42	42	46	48	48	54
West Virginia.....	49	47	45	43	44	45	41	45	46	47	48	54
North Carolina.....	45	42	41	40	36	40	42	42	44	46	49	51
South Carolina.....	53	49	44	47	50	48	50	51	52	53	52	56
Georgia.....	45	42	41	41	43	42	44	44	46	47	48	50
Florida.....	50	56	52	49	57	57	53	53	56	54	59	61
Ohio.....	56	48	43	47	50	47	45	47	49	52	58	63
Indiana.....	53	43	40	44	46	46	44	45	45	48	54	58
Illinois.....	54	48	41	47	49	48	47	48	49	51	54	59
Michigan.....	58	51	44	50	54	50	48	50	52	54	59	63
Wisconsin.....	65	54	50	56	59	56	54	53	54	57	63	67
Minnesota.....	62	51	45	52	57	54	51	52	52	54	61	66
Iowa.....	60	51	44	49	54	52	48	51	51	53	58	63
Missouri.....	48	43	38	41	44	42	42	42	44	44	48	52
North Dakota.....	54	47	39	44	47	51	45	48	52	50	57	60
South Dakota.....	59	51	44	49	53	53	50	51	51	54	62	65
Nebraska.....	56	46	41	46	51	49	45	47	49	51	58	60
Kansas.....	53	47	40	45	48	48	46	48	50	50	56	60
Kentucky.....	40	39	36	38	40	40	38	38	39	41	43	49
Tennessee.....	38	40	36	35	36	36	35	36	37	38	41	44
Alabama.....	39	40	35	34	36	37	35	37	37	39	39	45
Mississippi.....	43	44	37	39	38	39	39	41	40	42	47	48
Louisiana.....	55	49	46	46	51	51	42	42	45	43	48	56
Texas.....	45	43	40	37	37	39	38	39	40	41	45	49
Oklahoma.....	48	44	40	41	46	44	44	43	44	46	52	56
Arkansas.....	43	40	37	38	36	37	40	38	40	41	46	50
Montana.....	56	52	44	48	50	50	48	47	49	52	57	60
Wyoming.....	61	56	46	52	49	50	50	48	49	54	60	67
Colorado.....	60	56	43	50	53	49	48	51	53	54	60	65
New Mexico.....	64	62	57	55	58	60	55	52	51	59	60	65
Arizona.....	70	75	60	66	58	65	61	64	59	58	75	69
Utah.....	53	48	42	48	55	50	45	46	51	53	58	63
Nevada.....	67	64	45	45	50	50	55	.....	59	65	56	72
Idaho.....	59	56	47	53	53	54	48	54	53	59	64	65
Washington.....	63	65	53	57	58	56	56	59	59	65	65	68
Oregon.....	62	59	52	54	54	53	52	53	59	61	65	65
California.....	62	58	54	56	54	58	56	58	55	60	65	67
United States.....	54.9	49.6	43.8	47.6	50.3	49.1	47.2	48.2	49.7	51.5	56.0	60.0
1918.....	43.1	43.7	43.4	40.7	39.9	38.6	38.2	39.7	41.4	47.2	49.7	52.7
1917.....	34.0	33.5	34.1	33.5	36.1	35.0	33.5	34.0	36.1	38.9	40.9	41.9
1916.....	28.3	27.6	27.1	27.6	27.9	26.5	25.7	26.1	27.4	29.0	31.1	34.4
1915.....	28.7	27.9	26.8	25.8	25.7	24.8	24.2	24.2	24.5	25.3	26.4	27.6
1914.....	29.2	27.4	26.0	24.9	23.8	22.8	22.9	23.7	25.3	26.0	26.3	28.4
1913.....	28.4	27.6	27.5	27.6	27.0	25.5	24.7	24.9	25.9	27.5	28.2	29.2
1912.....	28.1	29.0	27.2	26.1	26.0	24.8	23.4	23.7	24.2	25.6	26.9	28.8
1911.....	27.8	24.1	22.7	22.6	21.4	20.3	20.4	21.7	23.1	23.8	25.2	27.4
1910.....	28.7	27.9	26.3	25.8	25.5	24.1	23.3	23.8	25.2	26.2	27.1	27.8
1909.....	.....	25.1	24.5	24.2	24.0	22.5	21.9	22.4	23.3	25.0	26.2	27.4



BUTTER AND EGGS—Continued.

TABLE 238.—Butter: International trade, calendar years 1909–1913, 1917, and 1918.

[Butter includes all butter made from milk, melted and renovated butter, but does not include margarine, coco butter, or ghee. See "General note," Table 220.]

EXPORTS.

[000 omitted.]

Country.	Average, 1909–1913.	1917 (preliminary).	1918 (preliminary).	Country.	Average, 1909–1913.	1919 (preliminary).	1918 (preliminary).
<i>From—</i>	<i>Pounds.</i>	<i>Pounds.</i>	<i>Pounds.</i>	<i>From—</i>	<i>Pounds.</i>	<i>Pounds.</i>	<i>Pounds.</i>
Argentina.....	6,934	21,672	41,821	Netherlands.....	75,133	54,216	5,414
Australia.....	77,859	72,278	.....	New Zealand.....	38,761	28,492	48,275
Austria-Hungary.....	4,267	.....	.....	Norway.....	3,137	(1)	.....
Belgium.....	3,125	.....	.....	Russia.....	150,294	3	.....
Canada.....	3,973	4,345	10,919	Sweden.....	45,870	.....	.....
Denmark.....	195,530	135,502	32,126	United States.....	4,125	7,193	26,194
Finland.....	26,337	.....	.....	Other countries.....	4,811	.....	.....
France.....	40,769	7,514	2,620				
Germany.....	498	.....	.....				
Italy.....	7,870	172	109	Total.....	689,293	.....	.....

IMPORTS.

<i>Into—</i>				<i>Into—</i>			
Austria-Hungary.....	6,281	.....	.....	Germany.....	111,441	.....	.....
Belgium.....	14,024	.....	.....	Netherlands.....	4,987	.....	.....
Brazil.....	4,551	14	.....	Russia.....	2,202	.....	.....
British South Africa.....	4,234	.....	.....	Sweden.....	330	15,756	.....
Canada.....	3,388	466	864	Switzerland.....	11,106	369	54
Denmark.....	6,241	1	.....	United Kingdom.....	455,489	201,605	176,692
Dutch East Indies.....	4,152	4,308	.....	Other countries.....	27,364	.....	.....
Egypt.....	2,350	533	302				
Finland.....	2,370	.....	.....	Total.....	674,223	.....	.....
France.....	13,713	742	984				

<sup>1</sup> Less than 500 pounds.

TABLE 239.—Butter: Receipts at seven leading markets in the United States, 1891–1919.

[From Board of Trade, Chamber of Commerce, and Merchants' Exchange reports; for 1917 and subsequently from Bureau of Markets.]

[000 omitted.]

Year.	Boston.	Chicago.	Milwaukee.	St. Louis.	San Francisco.	Total 5 cities.	Cincinnati.	New York.
	<i>Pounds.</i>	<i>Pounds.</i>	<i>Pounds.</i>	<i>Pounds.</i>	<i>Pounds.</i>	<i>Pounds.</i>	<i>Packages.</i>	<i>Packages.</i>
Averages:								
1891–1895.....	40,955	145,225	3,996	13,944	15,240	219,360	88	1,741
1896–1900.....	50,790	232,289	5,096	14,582	14,476	317,233	157	2,010
1901–1905.....	57,716	245,203	7,164	14,685	15,026	339,794	177	2,122
1906–1910.....	66,612	286,518	8,001	17,903	13,581	392,615	169	2,207
1901.....	57,500	253,809	5,590	13,477	14,972	345,348	238	2,040
1902.....	54,574	219,233	7,290	14,573	14,801	310,471	223	1,933
1903.....	54,347	232,032	6,857	14,080	13,570	320,886	121	2,113
1904.....	55,435	249,024	7,993	15,727	14,336	342,515	147	2,170
1905.....	66,725	271,915	8,091	15,566	17,450	379,747	155	2,355
1906.....	65,152	248,648	8,209	13,198	9,282	344,489	205	2,242
1907.....	63,589	263,715	8,219	13,453	17,359	366,335	187	2,113
1908.....	69,843	316,695	8,798	18,614	13,833	427,783	166	2,175
1909.....	65,054	284,547	7,458	21,086	14,486	392,631	150	2,250
1910.....	69,421	318,986	7,319	23,163	13,994	432,883	135	2,257
1911.....	63,874	334,932	8,632	24,839	21,118	453,395	162	2,405
1912.....	71,609	287,799	6,927	20,399	24,887	411,621	120	2,433
1913.....	71,703	286,220	9,415	24,683	23,027	415,051	102	2,522
1914.....	73,028	311,557	9,716	24,614	22,421	441,336	72	2,505
1915.....	82,082	344,879	8,679	21,234	28,349	485,253	129	2,741
1916.....	79,305	359,195	7,976	16,445	28,029	490,950	151	2,918
1917.....	69,168	323,100	6,116	16,996	25,032	440,412	63	2,575
1918.....	71,440	277,661	5,094	14,164	22,908	391,267	68	2,804
							Philadelphia.	
1919.....	73,223	185,779	6,114	18,111	22,031	305,528	683	2,980

BUTTER AND EGGS—Continued.

TABLE 239.—Butter: Receipts at seven leading markets in the United States, 1891-1919—Continued.

[000 omitted.]

Year.	Boston.	Chicago.	Mil-waukee.	St. Louis.	San Fran-cisco.	Total 5 cities.	Philadel-phia.	New York.
1919.	<i>Pounds.</i>	<i>Pounds.</i>	<i>Pounds.</i>	<i>Pounds.</i>	<i>Pounds.</i>	<i>Pounds.</i>	<i>Packages.</i>	<i>Packages.</i>
January.....	4,014	12,324	457	1,313	1,266	19,374	51	219
February.....	3,821	10,177	434	1,188	1,479	17,099	43	215
March.....	3,140	11,458	480	1,052	2,014	18,144	50	216
April.....	4,378	12,891	489	1,167	2,792	21,717	55	228
May.....	9,554	23,168	559	2,069	2,979	38,329	68	305
June.....	14,107	33,373	786	2,337	2,434	53,037	89	379
July.....	13,699	24,627	782	1,923	2,202	43,233	67	312
August.....	7,609	18,556	487	1,802	1,832	30,286	58	263
September.....	5,241	13,156	509	1,313	1,094	21,313	55	262
October.....	3,412	10,758	444	1,381	1,337	17,332	59	215
November.....	2,210	7,722	348	1,317	1,333	12,930	56	204
December.....	2,038	7,569	339	1,249	1,269	12,464	40	161

TABLE 240.—Eggs: Wholesale price per dozen, 1913-1919.

Date.	Chicago, fresh firsts.			Cincinnati. <sup>1</sup>			St. Louis, fresh firsts.			Milwaukee, fresh firsts.			New York, fresh firsts.		
	Low.	High.	Average.	Low.	High.	Average.	Low.	High.	Average.	Low.	High.	Average.	Low.	High.	Average.
1913.	<i>Cts.</i>	<i>Cts.</i>	<i>Cts.</i>	<i>Cts.</i>	<i>Cts.</i>	<i>Cts.</i>	<i>Cts.</i>	<i>Cts.</i>	<i>Cts.</i>	<i>Cts.</i>	<i>Cts.</i>	<i>Cts.</i>	<i>Cts.</i>	<i>Cts.</i>	<i>Cts.</i>
January-June.....	16½	27½	.....	15½	27½	.....	14½	25	.....	14	25	.....	20	40	.....
July-December.....	16	37	.....	18½	42	.....	12	35	.....	13	35	.....	25	65	.....
1914.															
January-June.....	17	32½	.....	16½	36	.....	14	31	.....	15	30	.....	20	50	.....
July-December.....	18	36	.....	18½	38½	.....	18	35	.....	16	32	.....	24	62	.....
1915.															
January-June.....	16	38	.....	12½	40½	.....	15½	37½	.....	15½	34	.....	18	44	.....
July-December.....	16	30½	.....	10	36	.....	14½	30	.....	15½	32	.....	18	40	.....
1916.															
January-June.....	18½	32½	.....	17	34½	.....	17	31	.....	17	31	.....	20½	35	.....
July-December.....	21½	41	.....	17½	47	.....	22	39	.....	19	38	.....	23½	47	.....
1917.															
January-June.....	26	49	.....	22	53	.....	25½	44	.....	25½	44	.....	28½	53	.....
July-December.....	30½	57	.....	20	57	.....	26	51	.....	30½	55	.....	34	62	.....
1918.															
January-June.....	29	63	40.1	26	66	38.6	26	59	38.0	30	58	47.4	31½	70	44.5
July-December.....	34	65	48.3	33	65	46.4	30	63	45.6	34	63	46.8	36	72	52.7
1919.															
January.....	43½	63½	56.6	52	62	57.5	38	62	54.4	45	60	55.3	57½	68	62.5
February.....	35	44	38.9	32½	38	35.2	33	40½	37.0	35	43	37.0	40½	51½	43.9
March.....	37½	41	38.8	36	40	37.9	35½	40	38.0	38	39	38.2	39½	45½	42.1
April.....	38½	43½	39.9	38½	40½	39.5	37	41	38.8	37½	42	39.6	40½	45½	43.2
May.....	41½	45	43.0	40½	44	42.1	37½	43	40.6	42	43½	42.7	43½	49	46.1
June.....	37	41½	39.7	36	41	38.0	34	38½	35.7	38	42	39.3	36½	48	43.7
January-June...	35	63½	42.8	32½	52	41.7	33	62	40.7	35	60	42.0	36½	68	46.9
July.....	39	43½	41.4	43	44	43.8	36½	38½	38.0	39	43	40.6	51	55	52.8
August.....	40	43	41.7	42	46	44.5	36½	41	39.5	40½	43	41.8	54	56	54.6
September.....	42½	52	44.7	47	50	48.5	41	47½	43.2	40	48	43.4	54	64	59.6
October.....	51	58½	55.7	55	58	57.0	47	56½	51.7	48	56	52.9	64	70	67.2
November.....	57½	75	64.6	.....	.....	.....	56½	69	62.4	.....	.....	.....	69	84	75.1
December.....	65	80	73.8	74	78	74.0	60	72	66.1	60	74	63.8	67	94	76.9
July-December..	39	80	53.6	42	78	55.7	36½	72	50.2	39	74	50.9	51	94	64.4

<sup>1</sup> 1918, fresh firsts; previous years include seconds.

BUTTER AND EGGS—Continued.

TABLE 241.—Eggs: Average price received by farmers on 1st of each month, by States 1918, and United States 1909-1918.

State and year.	Eggs, cents per dozen.											
	Jan.	Feb.	Mar.	Apr.	May.	June.	July.	Aug.	Sept.	Oct.	Nov.	Dec.
Maine.....	72	63	45	42	41	49	51	59	62	63	70	78
New Hampshire.....	77	63	48	45	45	51	56	60	60	64	74	88
Vermont.....	70	59	44	41	43	46	48	57	59	61	67	77
Massachusetts.....	88	71	55	56	55	57	62	66	71	73	84	92
Rhode Island.....	82	62	55	43	54	62	.....	55	69	68	77	93
Connecticut.....	81	67	48	43	49	53	57	64	69	70	80	90
New York.....	71	61	43	41	43	47	49	53	57	60	68	80
New Jersey.....	73	68	47	42	48	52	55	60	63	65	75	84
Pennsylvania.....	63	58	39	38	40	42	43	48	50	55	64	72
Delaware.....	58	52	38	39	40	41	42	45	48	54	65	71
Maryland.....	62	55	38	36	38	40	41	43	46	48	60	67
Virginia.....	55	52	37	33	37	39	40	40	43	46	53	60
West Virginia.....	58	52	37	34	37	39	39	41	42	46	52	60
North Carolina.....	50	45	31	30	32	35	36	36	41	46	49	54
South Carolina.....	52	47	36	31	33	37	40	37	41	49	53	54
Georgia.....	54	44	31	30	32	35	35	36	40	45	48	54
Florida.....	56	53	35	33	38	36	38	39	47	48	54	61
Ohio.....	58	49	35	35	40	41	38	42	42	47	58	67
Indiana.....	52	45	33	34	38	39	36	40	40	44	56	63
Illinois.....	56	45	33	34	37	39	35	37	39	42	53	61
Michigan.....	58	49	36	37	38	41	38	44	43	44	56	61
Wisconsin.....	56	48	33	34	38	40	37	38	39	43	50	60
Minnesota.....	53	42	30	33	37	38	34	36	37	41	51	60
Iowa.....	56	45	30	34	37	38	34	37	37	41	51	57
Missouri.....	53	44	32	34	36	36	32	34	35	38	49	58
North Dakota.....	50	44	30	31	33	36	31	33	35	36	43	54
South Dakota.....	51	43	28	31	35	36	32	33	35	38	50	57
Nebraska.....	50	41	31	32	34	36	31	32	33	37	50	56
Kansas.....	55	43	30	33	35	35	32	33	34	38	50	59
Kentucky.....	49	45	32	32	35	36	33	35	36	41	48	56
Tennessee.....	51	44	30	31	33	35	32	33	35	39	46	55
Alabama.....	49	43	28	27	29	32	31	33	36	41	41	49
Mississippi.....	50	44	29	29	29	32	32	32	37	40	45	50
Louisiana.....	59	47	33	30	30	32	33	35	38	42	46	54
Texas.....	55	46	30	29	29	30	31	30	33	37	43	51
Oklahoma.....	58	45	30	30	33	34	32	31	32	35	45	56
Arkansas.....	49	42	27	29	29	30	30	30	34	39	46	51
Montana.....	64	50	33	33	31	34	37	39	41	43	58	65
Wyoming.....	61	58	40	36	37	34	39	41	46	47	60	66
Colorado.....	63	57	36	36	36	36	38	43	46	46	57	62
New Mexico.....	63	58	42	39	38	39	38	45	45	49	49	59
Arizona.....	67	82	54	50	45	50	51	51	61	55	60	77
Utah.....	56	46	34	32	34	34	32	33	35	39	47	60
Nevada.....	81	68	40	32	40	40	58	.....	60	66	4	72
Idaho.....	63	60	33	35	35	35	34	40	42	45	59	66
Washington.....	66	59	40	38	39	42	42	47	55	57	64	73
Oregon.....	65	56	39	37	39	40	41	44	50	53	60	71
California.....	69	55	40	34	37	43	44	46	47	54	67	68
United States.....	57.2	48.3	33.1	34.3	36.8	38.6	36.8	39.3	41.0	44.7	54.0	61.9
1918.....	46.3	49.4	40.4	31.2	31.0	29.8	30.7	34.4	36.4	41.6	47.2	55.0
1917.....	37.7	35.8	33.8	25.9	30.0	31.1	28.3	29.8	33.2	37.4	39.4	43.3
1916.....	30.6	26.8	21.2	17.9	18.1	19.0	19.7	20.7	23.3	28.1	32.2	38.1
1915.....	31.6	29.2	21.3	16.6	17.1	16.6	16.8	17.0	18.7	22.3	26.3	30.6
1914.....	30.7	28.4	24.2	17.6	16.8	17.3	17.6	18.2	21.0	23.5	25.3	29.7
1913.....	26.8	22.8	19.4	16.4	16.1	16.9	17.0	17.2	19.5	23.4	27.4	33.0
1912.....	29.5	29.1	24.5	17.8	17.1	16.7	16.7	17.4	19.1	22.0	25.9	29.7
1911.....	30.4	22.1	16.5	14.9	14.7	14.5	14.2	15.5	17.4	20.0	23.5	28.7
1910.....	30.5	28.9	22.9	18.6	18.6	18.3	18.2	17.6	19.4	22.4	25.3	29.0
1909.....	.....	25.8	20.1	16.8	17.8	18.4	18.5	19.2	20.2	22.1	24.8	28.4

## BUTTER AND EGGS—Continued.

TABLE 242.—Eggs: Receipts at seven leading markets in the United States, 1891-1919.  
 [From Board of Trade, Chamber of Commerce, and Merchants' Exchange reports; for 1917 and subsequently from Bureau of Markets.]

Year.	Boston.	Chicago.	Cincinnati.	Milwaukee.	New York.	St. Louis.	San Francisco.	Total.
<b>Averages:</b>	<i>Cases.</i>	<i>Cases.</i>	<i>Cases.</i>	<i>Cases.</i>	<i>Cases.</i>	<i>Cases.</i>	<i>Cases.</i>	<i>Cases.</i>
1891-1895.....	722,363	1,879,065	288,548	90,943	2,113,946	557,320	166,059	5,818,244
1896-1900.....	912,807	2,196,631	362,262	113,327	2,664,074	852,457	194,087	7,295,645
1901-1905.....	1,155,340	2,990,675	418,842	139,718	3,057,298	1,000,935	304,933	9,067,741
1906-1910.....	1,517,995	4,467,040	509,017	180,362	4,046,360	1,304,719	334,766	12,360,259
1901.....	1,040,555	2,783,709	493,218	128,179	2,909,194	1,022,646	277,500	8,655,001
1902.....	1,053,165	2,659,340	464,799	114,732	2,743,642	825,999	285,058	8,146,735
1903.....	1,164,777	3,279,248	338,327	129,278	2,940,091	959,648	335,228	9,146,597
1904.....	1,122,819	3,113,858	377,263	166,409	3,215,924	1,216,124	319,637	9,532,034
1905.....	1,395,385	3,117,221	420,604	159,990	3,477,638	980,257	307,243	9,858,338
1906.....	1,709,531	3,583,878	484,208	187,561	3,981,013	1,023,125	137,074	11,106,390
1907.....	1,594,576	4,780,356	588,636	176,826	4,262,153	1,288,977	379,439	13,070,963
1908.....	1,436,786	4,569,014	441,072	207,558	3,703,990	1,439,868	347,436	12,145,724
1909.....	1,417,397	4,557,906	519,652	160,418	3,903,867	1,395,987	340,185	12,295,412
1910.....	1,431,686	4,844,045	511,519	179,448	4,380,777	1,375,638	469,698	13,192,811
1911.....	1,441,768	4,707,335	605,131	175,270	5,021,757	1,736,915	587,687	14,275,863
1912.....	1,580,106	4,556,643	668,942	136,896	4,723,520	1,394,534	638,890	13,699,531
1913.....	1,589,400	4,593,800	594,954	191,059	4,713,555	1,398,065	573,042	13,653,875
1914.....	1,531,329	4,083,163	461,927	224,797	4,882,222	1,474,212	619,500	13,277,150
1915.....	1,757,594	4,896,246	812,371	192,743	5,585,329	1,492,729	629,577	15,366,589
1916.....	1,649,823	5,452,737	853,910	208,924	4,858,274	1,521,506	575,014	15,120,193
1917.....	1,501,956	5,678,679	184,022	134,625	4,357,061	1,373,120	715,768	13,945,231
1918.....	1,604,289	5,049,743	176,733	180,616	5,026,548	934,668	666,845	13,639,442
1919.....	1,658,990	4,616,652	1,704,377	262,583	6,007,641	1,873,584	607,921	16,821,748

Year.	Boston.	Chicago.	Philadelphia.	Milwaukee.	New York.	St. Louis.	San Francisco.	Total.
<b>1919.</b>	<i>Cases.</i>	<i>Cases.</i>	<i>Cases.</i>	<i>Cases.</i>	<i>Cases.</i>	<i>Cases.</i>	<i>Cases.</i>	<i>Cases.</i>
January.....	66,615	100,655	64,301	11,753	214,289	27,193	47,960	532,766
February.....	115,862	252,674	99,962	23,578	485,712	130,540	59,119	1,167,447
March.....	184,500	458,275	174,553	30,531	666,931	253,293	73,212	1,841,295
April.....	326,955	1,024,189	300,744	52,297	1,026,316	401,030	82,528	3,214,059
May.....	234,538	914,672	270,696	46,231	910,815	302,376	93,370	2,772,698
June.....	189,315	767,295	184,808	29,033	668,675	180,234	80,169	2,099,529
July.....	147,810	400,601	129,437	16,348	532,221	136,221	66,041	1,428,679
August.....	128,369	275,570	114,573	13,856	437,602	125,870	62,138	1,157,978
September.....	79,576	219,744	106,868	10,882	376,592	110,630	41,540	945,832
October.....	96,967	125,458	119,245	9,294	318,529	134,406	31,788	835,687
November.....	48,077	50,722	76,222	9,150	192,024	50,290	27,022	453,507
December.....	40,406	26,797	62,968	9,630	177,935	21,501	33,034	372,271

## CHEESE.

TABLE 243.—Cheese: International trade, calendar years 1909-1913, 1917, and 1918.  
 [Cheese includes all cheese made from milk; "cottage cheese," of course, is included. See "General note," Table 220.]

## EXPORTS.

[000 omitted.]

Country.	Average, 1909-1913.	1917 (prelim).	1918 (prelim).	Country.	Average, 1909-1913.	1917 (prelim).	1918 (prelim).
<i>From—</i>	<i>Pounds.</i>	<i>Pounds.</i>	<i>Pounds.</i>	<i>From—</i>	<i>Pounds.</i>	<i>Pounds.</i>	<i>Pounds.</i>
Bulgaria.....	5,584	.....	.....	Russia.....	7,011	.....	.....
Canada.....	167,260	176,380	164,163	Switzerland.....	70,075	12,861	2,680
France.....	26,880	8,814	5,213	United States.....	5,142	53,372	48,405
Germany.....	1,967	.....	.....	Other countries.....	10,705	.....	.....
Italy.....	60,560	4,337	938				
Netherlands.....	127,379	123,634	32,893	<b>Total.....</b>	<b>538,124</b>	.....	.....
New Zealand.....	55,561	.....	.....				

CHEESE—Continued.

TABLE 243.—Cheese: International trade, calendar years 1909–1913, 1917, and 1918—Continued.

IMPORTS.

[000 omitted.]

Country.	Average, 1909–1913.	1917 (pre-lim).	1918 (pre-lim).	Country.	Average, 1909–1913.	1917 (pre-lim).	1918 (pre-lim).
<i>Into—</i>	<i>Pounds.</i>	<i>Pounds.</i>	<i>Pounds.</i>	<i>Into—</i>	<i>Pounds.</i>	<i>Pounds.</i>	<i>Pounds.</i>
Algeria.....	6,592	2,821	2,470	Germany.....	48,687		
Argentina.....	10,447	689	82	Italy.....	13,308	9	746
Australia.....	360	46		Russia.....	3,911		
Austria-Hungary.....	12,298			Spain.....	5,032	410	238
Belgium.....	31,771			Switzerland.....	7,150	214	87
Brazil.....	4,178	337		United Kingdom.....	257,407	327,981	263,132
British South Africa.....	5,006			United States.....	46,346	6,333	7,562
Cuba.....	4,520	1,835	3,318	Other countries.....	19,590		
Denmark.....	1,414	39					
Egypt.....	8,182	533	302				
France.....	49,056	12,047	11,206	Total.....	535,255		

CHICKENS.

TABLE 244.—Chickens: Average price received by farmers on 1st of each month, by States 1919, and United States 1909–1918.

State.	Chickens, cents per pound.											
	Jan.	Feb.	Mar.	Apr.	May.	June.	July.	Aug.	Sept.	Oct.	Nov.	Dec.
Maine.....	29.9	31.5	30.4	29.8	30.0	34.1	35.4	34.2	32.4	32.0	29.0	30.6
New Hampshire.....	30.5	31.8	26.7	30.3	31.0	34.3	30.5	30.4	30.3	31.2	31.8	30.0
Vermont.....	28.3	29.1	26.8	29.4	30.0	29.4	29.7	34.4	32.6	31.4	29.1	30.0
Massachusetts.....	36.0	35.5	33.8	31.8	31.8	33.2	35.7	39.8	38.0	32.5	40.0	35.5
Rhode Island.....	32.5	33.5	32.0	30.0	33.8	35.0	30.0	36.5	40.0	39.0	35.0	39.0
Connecticut.....	34.0	31.6	31.4	33.6	34.1	35.0	36.0	38.4	39.3	35.3	37.2	35.5
New York.....	29.3	29.3	27.8	31.0	33.0	34.0	33.7	34.7	34.5	32.1	30.9	29.5
New Jersey.....	32.5	30.2	33.2	32.6	36.2	35.9	35.5	37.3	36.8	35.0	32.9	34.5
Pennsylvania.....	26.9	26.1	28.1	28.5	31.0	31.5	31.3	31.8	32.1	31.3	28.6	27.0
Delaware.....	26.0	26.5	27.0	35.7	30.0	30.0	37.5		35.0	32.5	27.0	28.0
Maryland.....	28.1	28.5	29.7	30.0	32.5	29.8	34.3	32.3	33.2	30.4	29.1	28.0
Virginia.....	26.4	25.9	26.2	27.7	30.0	34.0	33.2	31.3	32.5	31.8	31.5	30.0
West Virginia.....	22.3	23.7	23.2	22.6	24.9	26.0	25.2	25.6	27.4	24.9	23.8	25.0
North Carolina.....	21.4	20.9	20.8	22.6	23.7	27.2	27.8	27.1	26.6	26.4	27.4	26.0
South Carolina.....	28.0	22.1	24.4	24.8	23.5	23.9	30.7	27.7	29.4	29.5	29.9	30.0
Georgia.....	24.5	22.4	20.8	21.3	22.9	23.6	23.6	26.5	26.2	25.8	27.4	27.4
Florida.....	27.5	26.0	25.0	25.4	27.2	29.4	29.5	26.2	31.2	29.6	32.1	30.0
Ohio.....	22.6	22.6	23.6	25.5	28.2	28.3	26.5	28.0	27.3	25.0	21.9	22.1
Indiana.....	20.5	21.1	22.2	24.1	27.0	27.5	26.0	26.0	25.7	23.8	21.0	20.6
Illinois.....	20.4	20.7	21.9	23.8	25.8	25.7	23.6	25.7	25.2	22.8	20.6	20.5
Michigan.....	21.8	21.1	22.9	23.9	25.0	25.3	24.6	25.9	26.2	24.8	21.0	20.3
Wisconsin.....	20.3	19.8	20.7	22.4	24.6	23.7	23.1	25.1	23.8	22.4	20.1	19.0
Minnesota.....	17.1	17.5	18.1	19.3	20.4	20.4	21.0	21.0	21.1	19.6	17.3	16.4
Iowa.....	19.7	19.8	20.3	20.9	22.8	22.9	21.5	22.5	22.3	21.1	18.5	18.2
Missouri.....	19.5	20.0	21.4	23.7	25.1	25.1	24.0	25.4	25.0	21.8	20.3	19.3
North Dakota.....	15.5	15.3	15.6	15.8	17.8	17.9	17.6	18.9	20.7	20.8	15.4	15.0
South Dakota.....	16.6	16.2	17.6	17.5	18.8	18.5	19.0	20.2	22.0	20.1	18.4	17.0
Nebraska.....	18.0	19.2	19.1	20.6	22.1	22.2	20.5	22.5	21.5	20.1	18.6	18.5
Kansas.....	19.0	18.9	20.3	21.3	22.1	23.0	23.1	23.4	22.3	21.1	20.0	19.1
Kentucky.....	19.5	19.7	20.8	23.3	24.9	26.1	25.6	26.4	24.5	22.7	21.1	20.3
Tennessee.....	19.1	19.2	20.8	23.3	24.6	25.6	25.1	25.1	23.6	21.9	22.3	21.0
Alabama.....	21.1	21.3	20.5	20.7	22.1	24.5	24.7	24.6	24.3	24.1	24.9	25.0
Mississippi.....	23.1	21.9	20.2	21.5	23.6	24.3	24.0	24.1	24.0	24.7	24.2	25.0
Louisiana.....	25.5	23.2	23.9	23.5	22.2	25.2	25.0	25.6	25.9	24.9	26.2	25.5
Texas.....	19.3	18.6	19.5	19.8	20.7	22.5	22.9	22.0	21.9	21.2	22.0	21.7
Oklahoma.....	17.9	18.0	19.6	21.4	22.2	22.1	22.1	21.5	21.6	20.9	20.3	19.0
Arkansas.....	16.7	16.6	17.2	19.1	20.2	19.3	20.4	20.9	20.8	19.0	21.7	19.2
Montana.....	17.8	20.3	20.3	19.7	22.1	21.6	21.5	24.5	19.0	21.6	17.2	16.5
Wyoming.....	19.3	18.6	22.5	21.5	21.3	21.5	23.8	23.1	25.8	22.6	27.1	24.0
Colorado.....	20.4	22.2	20.7	20.5	22.8	22.3	22.8	25.0	24.6	23.3	22.4	22.0
New Mexico.....	18.1	25.9	21.9	21.0	20.8	22.6	20.6	25.2	24.4	22.3	22.0	26.3
Arizona.....	28.3	38.8	33.5	30.0	31.0	27.3	31.0	30.0	35.0	26.8	40.0	35.0
Utah.....	18.5	19.5	17.2	19.8	21.6	21.9	19.7	18.3	20.6	20.9	20.1	19.3
Nevada.....	37.0	35.8	29.0	28.0	27.5	29.0	40.0		35.0	36.2	36.2	29.8
Idaho.....	18.2	18.1	18.1	19.1	19.9	18.2	20.1	20.1	20.9	20.9	20.9	20.5
Washington.....	23.9	25.5	25.1	26.6	27.3	27.4	28.9	27.7	27.8	27.9	25.9	26.0
Oregon.....	23.5	24.4	25.1	26.1	29.8	27.2	25.6	26.5	25.2	25.4	25.0	24.5
California.....	29.5	28.4	29.0	27.9	31.1	30.0	26.8	29.8	28.4	30.2	30.8	29.0
United States.....	21.7	21.6	22.2	23.5	25.2	25.7	25.2	25.9	25.7	24.2	22.9	22.3

## CHICKENS—Continued.

TABLE 244.—Chickens: Average price received by farmers on 1st of each month, by States 1919, and United States 1909-1918—Continued.

Year.	Chickens, cents per pound.											
	Jan.	Feb.	Mar.	Apr.	May.	June.	July.	Aug.	Sept.	Oct.	Nov.	Dec.
1918.....	17.9	18.8	19.9	19.8	19.8	20.0	21.2	22.6	22.8	23.1	22.4	21.8
1917.....	13.9	14.7	15.5	16.1	17.5	17.5	17.3	17.1	17.2	18.1	17.7	17.5
1916.....	11.4	11.9	12.2	12.6	13.2	13.5	13.8	13.8	13.9	14.3	14.3	14.2
1915.....	11.2	11.5	11.7	11.9	12.1	12.2	12.2	12.2	12.1	12.0	11.8	11.5
1914.....	11.5	11.7	12.1	12.3	12.5	12.5	12.7	12.8	12.7	12.5	11.9	11.3
1913.....	10.7	10.9	11.1	11.6	11.8	12.0	12.1	12.4	12.4	12.5	12.1	11.5
1912.....	9.8	10.3	10.5	10.8	11.1	11.1	11.0	11.3	11.3	11.5	11.2	10.8
1911.....	10.5	10.6	10.6	10.8	11.0	11.0	11.2	11.2	11.1	10.9	10.3	9.6
1910.....	10.9	11.1	11.6	11.9	12.4	12.4	12.3	12.2	11.9	11.6	11.3	10.6
1909.....		9.9	10.0	10.2	10.6	10.9	11.1	11.2	11.1	11.3	10.9	10.8

TABLE 245.—Turkeys and chickens: Farm price, cents per pound, 15th. of month, 1915-1920.

Date.	1919-20		1918-19		1917-18		1916-17		1915-16	
	Turkeys.	Chickens.	Turkeys.	Chickens.	Turkeys.	Chickens.	Turkeys.	Chickens.	Turkeys.	Chickens.
Oct. 15.....	26.6	23.3	23.9	22.2	20.0	18.5	17.0	14.4	13.7	11.8
Nov. 15.....	28.3	22.0	25.7	21.7	21.0	17.0	18.6	13.9	14.8	11.5
Dec. 15.....	31.1	22.0	27.0	22.4	23.0	17.5	19.6	13.6	15.5	11.2
Jan. 15.....	32.0	23.3	27.3	22.1	22.9	18.4	19.5	14.1	15.6	11.5

## SHEEP AND WOOL.

TABLE 246.—Sheep: Number and value on farms in the United States, 1867-1920.

NOTE.—Figures in *italics* are census returns; figures in roman are estimates of the Department of Agriculture. Estimates of numbers are obtained by applying estimated percentages of increase or decrease to the published numbers of the preceding year, except that a revised base is used for applying percentage estimates whenever new census data are available. It should also be observed that the census of 1910 giving numbers as of Apr. 15, is not strictly comparable with former censuses, which related to numbers June 1.

Jan. 1—	Number.	Price per head Jan. 1.	Farm value Jan. 1.	Jan. 1—	Number.	Price per head Jan. 1.	Farm value Jan. 1.
1867.....	39,385,000	\$2.50	\$98,644,000	1893.....	47,274,000	\$2.66	\$125,909,000
1868.....	38,992,000	1.82	71,053,000	1894.....	45,048,000	1.98	89,186,000
1869.....	37,724,000	1.64	62,037,000	1895.....	42,294,000	1.58	66,686,000
1870.....	40,853,000	1.96	79,876,000	1896.....	38,299,000	1.70	65,168,000
1870, census, June 1.....	<i>28,477,951</i>			1897.....	36,819,000	1.82	67,021,000
1871.....	31,851,000	2.14	68,310,000	1898.....	37,657,000	2.46	92,721,000
1872.....	31,679,000	2.61	82,768,000	1899.....	39,114,000	2.75	107,698,000
1873.....	33,002,000	2.71	89,427,000	1900.....	41,883,000	2.93	122,666,000
1874.....	33,938,000	2.43	82,353,000	1900, census, June 1.....	<i>61,503,713</i>		
1875.....	33,784,000	2.55	86,278,000	1901 <sup>1</sup> .....	59,757,000	2.98	178,072,000
1876.....	35,935,000	2.37	85,121,000	1902.....	62,039,000	2.65	164,446,000
1877.....	35,804,000	2.13	76,362,000	1903.....	63,965,000	2.63	168,316,000
1878.....	35,740,000	2.21	78,898,000	1904.....	51,630,000	2.59	133,530,000
1879.....	38,124,000	2.07	78,965,000	1905.....	45,170,000	2.82	127,332,000
1880.....	40,766,000	2.21	90,231,000	1906.....	50,632,000	3.54	179,056,000
1880, census, June 1.....	<i>35,192,074</i>			1907.....	53,240,000	3.84	204,210,000
1881.....	43,570,000	2.39	104,071,000	1908.....	54,631,000	3.88	211,736,000
1882.....	45,016,000	2.37	106,596,000	1909.....	56,084,000	3.43	192,632,000
1883.....	49,237,000	2.53	124,366,000	1910.....	57,216,000		
1884.....	50,627,000	2.37	119,903,000	1910, census, Apr. 15.....	<i>52,447,861</i>	4.12	216,030,000
1885.....	50,360,000	2.14	107,961,000	1911 <sup>1</sup> .....	53,633,000	3.91	209,535,000
1886.....	48,322,000	1.91	92,444,000	1912.....	52,362,000	3.46	181,170,000
1887.....	44,759,000	2.01	89,873,000	1913.....	51,482,000	3.94	202,779,000
1888.....	43,545,000	2.05	89,280,000	1914.....	49,719,000	4.02	200,045,000
1889.....	42,599,000	2.13	90,640,000	1915.....	49,956,000	4.50	224,687,000
1890.....	44,336,000	2.27	100,660,000	1916.....	48,625,000	5.17	251,594,000
1890, census, June 1.....	<i>35,935,364</i>			1917.....	47,616,000	7.13	339,529,000
1891.....	43,431,000	2.50	108,397,000	1918.....	48,603,000	11.82	574,575,000
1892.....	44,938,000	2.58	116,121,000	1919.....	48,856,000	11.63	568,265,000
				1920.....	48,615,000	10.52	511,654,000

<sup>1</sup> Estimates of numbers revised, based on census data.

SHEEP AND WOOL—Continued.

TABLE 247.—*Sheep: Number and value on farms Jan. 1, 1919 and 1920, by States.*

State.	Number (thousands), Jan. 1—		Average price per head, Jan. 1—		Farm value (thousands of dollars), Jan. 1—	
	1920	1919	1920	1919	1920	1919
Maine.....	180	173	\$9.50	\$11.10	\$1,710	\$1,920
New Hampshire.....	39	38	9.80	12.00	382	456
Vermont.....	105	107	11.50	12.70	1,208	1,359
Massachusetts.....	30	28	12.70	12.50	381	350
Rhode Island.....	6	7	12.20	12.50	73	88
Connecticut.....	29	24	12.80	13.30	371	319
New York.....	824	800	12.40	13.90	10,218	11,120
New Jersey.....	30	29	11.00	13.20	330	383
Pennsylvania.....	939	930	11.60	11.70	10,892	10,881
Delaware.....	10	10	10.40	10.30	104	103
Maryland.....	250	246	10.90	11.30	2,725	2,780
Virginia.....	714	700	11.50	12.50	8,211	8,750
West Virginia.....	772	766	10.60	11.70	8,183	8,962
North Carolina.....	144	138	9.50	8.70	1,368	1,201
South Carolina.....	27	29	7.10	6.50	192	188
Georgia.....	125	135	4.90	5.80	612	783
Florida.....	107	105	5.20	4.10	556	430
Ohio.....	3,010	2,980	10.10	11.00	30,401	32,780
Indiana.....	1,089	1,078	11.80	13.90	12,850	14,984
Illinois.....	1,010	1,000	12.60	14.20	12,726	14,200
Michigan.....	2,224	2,119	11.80	12.50	26,243	26,488
Wisconsin.....	687	680	10.80	12.40	7,420	8,432
Minnesota.....	668	642	11.00	13.20	7,348	8,474
Iowa.....	1,321	1,270	12.00	13.70	15,852	17,399
Missouri.....	1,525	1,495	11.90	13.20	18,148	19,734
North Dakota.....	286	265	11.00	12.60	3,146	3,339
South Dakota.....	850	810	10.00	12.20	8,500	9,882
Nebraska.....	323	294	11.10	11.90	3,585	3,499
Kansas.....	506	460	11.60	12.80	5,870	5,888
Kentucky.....	1,236	1,274	10.90	13.10	13,472	16,689
Tennessee.....	584	556	10.50	11.80	6,132	6,561
Alabama.....	137	140	5.60	6.40	767	896
Mississippi.....	175	180	6.30	6.60	1,102	1,188
Louisiana.....	230	230	5.40	5.20	1,242	1,196
Texas.....	2,790	2,232	9.90	9.40	27,621	20,981
Oklahoma.....	131	125	11.10	11.80	1,454	1,475
Arkansas.....	201	161	7.40	8.20	1,487	1,320
Montana.....	2,791	2,984	10.30	11.80	28,747	35,211
Wyoming.....	3,200	4,000	10.20	12.30	32,640	49,200
Colorado.....	2,121	2,209	9.80	10.90	20,786	24,078
New Mexico.....	2,538	2,820	9.30	8.50	23,603	23,970
Arizona.....	1,300	1,400	9.60	10.00	12,480	14,000
Utah.....	2,245	2,223	9.80	11.00	22,001	24,453
Nevada.....	1,596	1,520	10.30	11.80	16,439	17,936
Idaho.....	3,234	3,234	10.40	12.20	33,634	39,455
Washington.....	757	780	11.00	11.80	8,327	9,204
Oregon.....	2,547	2,497	11.00	12.00	28,017	29,964
California.....	2,972	2,943	10.80	12.00	32,098	35,316
United States.....	48,615	48,866	10.52	11.63	511,654	568,265

TABLE 248.—*Sheep: Farm price per 100 pounds, 15th of month, 1910-1919.*

	1919	1918	1917	1916	1915	1914	1913	1912	1911	1910	Average.
Jan. 15.....	\$9.68	\$10.55	\$7.33	\$5.52	\$4.95	\$4.67	\$4.35	\$3.89	\$4.47	\$5.63	\$6.10
Feb. 15.....	9.95	10.75	8.17	5.90	5.14	4.67	4.63	4.01	4.34	5.09	6.26
Mar. 15.....	10.45	11.41	9.21	6.35	5.36	4.77	4.97	4.12	4.45	5.64	6.67
Apr. 15.....	11.33	11.98	9.69	6.61	5.60	4.96	5.16	4.57	4.55	6.10	7.06
May 15.....	10.93	12.32	10.15	6.66	5.54	4.87	4.91	4.74	4.51	5.79	7.04
June 15.....	10.34	11.56	9.84	6.54	5.43	4.70	4.84	4.52	4.24	5.44	6.74
July 15.....	9.25	11.04	9.32	6.33	5.35	4.75	4.20	4.21	4.19	5.47	6.41
Aug. 15.....	9.06	10.99	9.33	6.22	5.16	4.87	4.32	4.26	3.98	4.68	6.29
Sept. 15.....	8.69	10.79	10.05	6.25	5.06	4.80	4.23	4.11	3.91	4.81	6.27
Oct. 15.....	8.46	10.35	10.24	6.20	5.18	4.81	4.16	4.19	3.68	4.68	6.20
Nov. 15.....	8.35	10.11	10.20	6.41	5.18	4.68	4.27	4.05	3.65	4.63	6.15
Dec. 15.....	8.53	9.46	10.44	6.77	5.38	4.95	4.46	4.21	3.71	4.54	6.24

## SHEEP AND WOOL—Continued.

TABLE 249.—Lambs: Farm price per 100 pounds, 15th of month, 1910-1919.

Date.	1919	1918	1917	1916	1915	1914	1913	1912	1911	1910	Average.
Jan. 15....	\$12.71	\$13.83	\$9.59	\$7.29	\$6.47	\$6.16	\$6.03	\$5.22	\$5.71	\$5.82	\$7.88
Feb. 15....	13.17	13.77	10.51	7.78	6.67	6.18	6.34	5.15	5.44	6.62	8.16
Mar. 15....	14.03	14.11	11.46	8.10	6.06	6.31	6.56	5.38	5.49	7.37	8.49
Apr. 15....	14.61	15.34	12.03	8.58	7.35	6.47	6.59	5.98	5.77	7.47	9.02
May 15....	14.34	15.39	12.51	8.49	7.32	6.49	6.66	6.16	5.74	7.26	9.04
June 15....	13.89	14.98	12.64	8.36	7.26	6.47	6.36	6.02	5.51	7.13	8.86
July 15....	13.09	14.20	11.19	8.16	7.21	6.55	6.05	5.74	5.42	6.71	8.43
Aug. 15....	12.91	14.20	12.08	8.15	6.70	6.26	5.50	5.60	5.25	5.70	8.24
Sept. 15....	12.25	13.73	13.06	8.22	6.71	6.27	5.51	5.49	5.02	5.85	8.21
Oct. 15....	11.47	13.20	14.09	8.02	6.70	6.09	5.51	5.42	4.68	5.78	8.10
Nov. 15....	11.45	12.54	13.79	8.41	6.76	6.14	5.64	5.37	4.68	5.54	8.03
Dec. 15....	11.85	12.44	13.81	8.72	7.02	6.33	5.85	5.70	4.93	5.60	8.22

TABLE 250.—Sheep: Imports, exports, and prices, 1893-1919.

Year ending June 30—	Imports.			Exports.		
	Number.	Value.	Average import price.	Number.	Value.	Average export price.
1893.....	459,484	\$1,682,977	\$3.66	37,260	\$126,394	\$3.39
1894.....	242,568	788,181	3.25	132,370	832,763	6.29
1895.....	291,461	682,618	2.34	405,748	2,630,686	6.48
1896.....	322,692	853,530	2.65	491,565	3,076,384	6.26
1897.....	405,633	1,019,668	2.51	244,120	1,531,645	6.27
1898.....	392,314	1,106,322	2.82	199,690	1,213,886	6.08
1899.....	345,911	1,200,081	3.47	143,286	853,555	5.96
1900.....	381,792	1,365,026	3.58	125,772	733,477	5.83
1901.....	331,488	1,236,277	3.73	297,925	1,933,000	6.49
1902.....	266,953	956,710	3.58	358,720	1,940,060	5.41
1903.....	301,623	1,036,934	3.44	176,961	1,067,860	6.03
1904.....	238,094	815,289	3.42	301,313	1,954,604	6.49
1905.....	186,942	704,721	3.77	268,365	1,687,321	6.29
1906.....	240,747	1,020,359	4.24	142,690	804,090	5.64
1907.....	224,798	1,120,425	4.98	135,344	750,242	5.54
1908.....	224,765	1,082,606	4.82	101,000	589,285	5.83
1909.....	102,663	502,640	4.90	67,656	365,155	5.40
1910.....	126,152	696,879	5.52	44,517	209,000	4.69
1911.....	53,455	377,625	7.06	121,491	636,272	5.24
1912.....	23,588	157,257	6.67	157,263	626,985	3.99
1913.....	15,428	90,021	5.83	187,132	605,725	3.24
1914.....	223,719	532,404	2.38	152,600	534,543	3.50
1915.....	153,317	533,967	3.48	47,213	182,278	3.86
1916.....	235,659	917,502	3.89	52,278	231,535	4.43
1917.....	160,422	856,645	5.34	58,811	367,935	6.26
1918.....	177,681	1,979,746	11.14	7,959	97,028	12.19
1919.....	163,283	1,914,473	11.72	16,117	187,347	11.62



SHEEP AND WOOL—Continued.

TABLE 251.—*Sheep: Wholesale price per 100 pounds, 1913–1919.*

Date.	Chicago.			Cincinnati.			St. Louis.			Kansas City.			Omaha.		
	Native.			Good to extra.			Good to choice natives.			Natives.			Western.		
	Low.	High.	Average.	Low.	High.	Average.	Low.	High.	Average.	Low.	High.	Average.	Low.	High.	Average.
1913.															
January-June.....	\$3.00	\$8.60	\$6.28	\$3.75	\$7.00	\$4.90	\$4.75	\$7.25	\$5.87	\$4.85	\$7.85	\$6.52	\$3.75	\$8.25	\$6.05
July-December.....	2.25	7.25	4.94	3.25	4.65	4.06	4.00	5.00	4.42	3.50	6.65	4.79	2.75	7.00	4.50
1914.															
January-June.....	4.00	7.75	5.96	4.10	6.15	5.03	5.00	6.50	5.82	4.25	7.25	6.00	4.25	7.50	6.41
July-December.....	4.25	8.10	6.08	4.00	5.25	4.81	4.50	5.75	5.20	3.40	7.00	5.52	4.25	8.00	5.65
1915.															
January-June.....	2.50	10.65	6.08	4.00	8.75	5.70	5.00	8.50	6.78	4.50	10.00	7.04	4.00	9.75	7.09
July-December.....	2.00	8.75	5.18	4.50	8.75	5.38	5.25	6.00	5.55	4.00	8.25	6.09	4.00	8.00	5.71
1916.															
January-June.....	4.25	10.90	7.71	3.75	8.75	6.90	6.50	8.85	7.96	5.00	11.50	8.40	4.50	11.00	8.13
July-December.....	3.00	10.25	5.80	5.25	8.50	5.33	7.25	9.00	7.44	6.00	11.75	7.96	5.50	11.75	7.46
1917.															
January-June.....	7.00	19.00	11.96	7.50	12.00	9.36	9.00	14.00	11.49	7.75	18.00	11.71	7.50	16.00	11.76
July-December.....	7.75	14.75	11.26	6.50	10.50	9.19	8.50	12.00	10.44	8.00	15.50	11.14	8.00	14.25	11.53
1918.															
January-June.....	6.00	19.75	12.91	9.00	15.50	11.46	10.00	18.00	13.40	10.50	19.00	14.21	10.00	18.75	13.94
July-December.....	6.00	16.60	10.61	6.00	12.50	9.67	7.00	13.50	9.74	7.00	17.00	11.23	7.00	14.50	11.00
1919.															
January.....	6.50	14.75	10.56	8.00	8.50	8.25	8.50	16.65	10.54	6.00	17.00	12.64	8.50	16.50	12.31
February.....	7.00	16.50	11.60	8.00	10.00	8.88	8.00	14.00	10.13	9.00	17.15	13.05	8.50	16.50	12.50
March.....	9.25	19.00	14.21	9.00	13.00	10.56	9.00	15.00	12.13	11.00	18.50	14.98	9.00	16.00	11.98
April.....	10.00	16.75	13.54	10.00	13.00	11.50	9.00	15.50	12.99	13.00	18.50	16.07	9.00	16.00	12.48
May.....	8.00	16.50	11.63	9.00	12.50	10.98	7.50	15.60	11.19	9.00	17.75	14.37	8.00	15.50	10.74
June.....	5.00	13.00	8.91	7.00	10.00	8.17	6.00	19.00	7.78	6.50	16.50	11.84	6.00	11.50	8.70
January-June.....	5.00	19.00	11.74	7.00	13.00	9.72	6.00	16.65	10.79	6.00	18.50	13.82	6.00	16.50	11.45
July.....	5.00	15.00	9.47	6.50	9.00	7.68	5.50	12.50	7.98	6.00	12.50	9.42	6.09	11.00	8.57
August.....	5.00	13.00	8.92	8.50	9.50	8.94	5.50	9.50	7.53	6.00	13.00	9.78	5.00	12.00	7.84
September.....	4.00	12.00	8.04	6.00	7.50	6.84	5.00	8.50	6.67	5.75	11.25	8.28	4.50	10.25	6.88
October.....	4.75	11.50	8.12	5.50	6.50	6.20	5.00	7.75	6.08	5.75	11.00	8.41	5.75	10.00	7.75
November.....	4.75	12.75	8.17	6.00	7.00	6.42	5.50	11.75	6.88	7.50	11.75	9.40	6.00	10.25	8.10
December.....	6.25	15.60	11.32	6.50	9.00	7.68	5.50	15.50	8.11	8.00	14.75	11.15	6.00	15.75	10.09
July-December.....	4.00	15.60	9.01	5.50	9.50	7.29	5.00	15.50	7.50	5.75	14.75	9.41	4.50	15.75	8.20

## SHEEP AND WOOL—Continued.

TABLE 252.—Wool: Estimated production, 1918 and 1919.

State.	Production (000 omitted).		Weight per fleece.		Number of fleeces (000 omitted).	
	1919	1918	1919	1918	1919	1918
	<i>Pounds.</i>	<i>Pounds.</i>	<i>Pounds.</i>	<i>Pounds.</i>	<i>Number.</i>	<i>Number.</i>
Maine.....	936	883	6.4	6.7	146	132
New Hampshire.....	202	192	6.6	7.0	31	27
Vermont.....	690	663	7.2	7.2	96	92
Massachusetts.....	125	119	6.6	6.0	19	20
Rhode Island.....	25	24	5.8	6.0	4	4
Connecticut.....	84	76	5.9	5.5	14	14
New York.....	4,022	3,830	7.0	7.0	575	547
New Jersey.....	92	88	7.0	5.5	13	16
Pennsylvania.....	5,013	4,774	7.0	6.7	716	713
Delaware.....	31	31	5.7	5.7	5	5
Maryland.....	812	773	6.0	5.8	135	133
Virginia.....	1,962	1,800	5.0	4.7	392	383
West Virginia.....	2,943	2,830	5.3	5.2	555	544
North Carolina.....	587	570	4.4	4.0	133	142
South Carolina.....	103	103	4.3	4.0	24	26
Georgia.....	422	418	3.1	2.9	136	144
Florida.....	460	426	3.5	3.2	131	133
Ohio.....	13,104	12,600	7.5	7.3	1,747	1,726
Indiana.....	5,337	4,765	7.4	7.1	721	671
Illinois.....	4,129	4,048	8.0	8.0	516	506
Michigan.....	9,554	8,765	7.4	7.4	1,291	1,184
Wisconsin.....	3,306	2,850	7.6	7.6	435	375
Minnesota.....	3,594	3,209	7.5	7.4	479	434
Iowa.....	5,060	4,600	8.0	7.5	632	613
Missouri.....	7,614	7,183	7.1	7.0	1,072	1,026
North Dakota.....	1,654	1,560	7.7	7.6	215	205
South Dakota.....	5,222	4,747	7.5	7.4	696	641
Nebraska.....	1,730	1,696	7.9	7.8	219	217
Kansas.....	1,754	1,624	7.6	7.6	231	214
Kentucky.....	3,211	3,058	5.2	4.9	618	624
Tennessee.....	2,052	1,954	4.8	4.6	428	425
Alabama.....	405	368	4.2	3.5	96	105
Mississippi.....	656	619	4.2	4.0	156	155
Louisiana.....	612	594	3.9	3.7	157	161
Texas.....	14,986	11,800	7.2	7.0	2,081	1,686
Oklahoma.....	526	511	7.0	6.8	75	75
Arkansas.....	422	402	4.9	4.9	86	82
Montana.....	17,751	18,685	8.4	8.2	2,113	2,279
Wyoming.....	33,415	32,760	8.5	8.4	3,931	3,900
Colorado.....	8,983	9,261	6.6	6.2	1,361	1,494
New Mexico.....	15,076	17,132	6.3	5.6	2,393	3,059
Arizona.....	5,236	5,630	6.3	6.1	831	923
Utah.....	15,800	15,800	7.4	7.7	2,135	2,052
Nevada.....	10,500	10,000	7.6	7.0	1,382	1,429
Idaho.....	22,145	21,500	8.4	7.9	2,636	2,722
Washington.....	5,779	5,504	8.6	8.6	672	640
Oregon.....	14,040	13,500	8.5	8.0	1,652	1,688
California.....	13,298	12,545	7.4	7.0	1,797	1,792
United States.....	265,460	256,870	7.4	7.1	35,979	36,178
Pulled wool.....	48,300	42,000				

TABLE 253.—Wool (unwashed): Farm price per pound, 15th of month, 1910-1919.

Date.	1919	1918	1917	1916	1915	1914	1913	1912	1911	1910	Average.
	<i>Cents.</i>	<i>Cents.</i>	<i>Cents.</i>	<i>Cents.</i>	<i>Cents.</i>	<i>Cents.</i>	<i>Cents.</i>	<i>Cents.</i>	<i>Cents.</i>	<i>Cents.</i>	<i>Cents.</i>
Jan. 15.....	55.2	58.1	31.8	23.3	18.6	15.7	18.6	16.2	17.3	24.5	27.9
Feb. 15.....	51.1	57.1	32.7	24.2	20.2	15.7	18.7	16.3	17.3	24.6	27.8
Mar. 15.....	51.3	60.0	36.7	25.9	22.8	16.4	18.4	16.9	16.8	24.9	29.0
Apr. 15.....	47.9	60.0	38.8	26.3	22.7	16.8	17.7	17.3	15.7	22.3	28.6
May 15.....	48.0	58.2	43.7	28.0	22.0	17.2	16.3	17.8	14.7	22.8	28.9
June 15.....	50.5	57.4	49.8	28.7	23.7	18.4	15.6	18.7	15.5	19.5	29.8
July 15.....	51.8	57.5	54.3	28.6	24.2	18.5	15.9	18.9	15.4	19.0	30.4
Aug. 15.....	52.2	57.4	54.8	29.0	23.8	18.7	15.8	18.8	16.0	19.5	30.6
Sept. 15.....	51.3	57.7	54.2	28.4	23.3	18.6	15.8	18.7	15.6	17.7	30.1
Oct. 15.....	50.6	57.7	55.5	28.7	22.7	18.0	15.5	18.5	15.5	18.1	30.1
Nov. 15.....	51.0	56.4	55.9	29.4	22.7	18.1	15.6	18.6	15.6	17.9	30.1
Dec. 15.....	51.6	56.2	58.2	30.8	23.3	18.6	16.1	18.6	15.5	17.8	30.7

SHEEP AND WOOL—Continued.

TABLE 254.—Wool: Wholesale price per pound in Boston, 1913-1919.

Date.	Ohio fine, unwashed.			Kentucky quarter-blood, unwashed.			Ohio XX, washed.			Ohio half-blood combing, washed.			Ohio Delaine, washed.			Michigan fine, unwashed.		
	Low.	High.	Average.	Low.	High.	Average.	Low.	High.	Average.	Low.	High.	Average.	Low.	High.	Average.	Low.	High.	Average.
1913.	Cts.	Cts.	Cts.	Cts.	Cts.	Cts.	Cts.	Cts.	Cts.	Cts.	Cts.	Cts.	Cts.	Cts.	Cts.	Cts.	Cts.	Cts.
January-June.....	20	24	22.4	24	32	28.6	27	32	29.4	23	29	26.6	27	34	30.8	19	23	21.1
July-December.....	20	21	20.5	23½	26	24.2	25	30	26.5	23	25	23.9	26	28	27.3	19	20	19.5
1914.																		
January-June.....	20	25	22.3	23½	27	24.5	25½	29	27.0	23	28	25.0	26	32	28.2	19	23	21.0
July-December.....	23	25	24.3	26	29	27.0	27	31½	29.6	27	30	28.3	28	32	30.9	22	23	22.8
1915.																		
January-June.....	23	29	26.7	29	39	35.5	29	34	32.0	29	38	34.0	30	37	33.4	22	26	23.8
July-December.....	25	27½	26.9	36	39½	38.0	32	32½	32.1	32½	36	34.4	33½	36	34.5	23	27½	23.8
1916.																		
January-June.....	26	31	29.6	38	41	39.4	32½	35	33.7	32	38	36.1	35½	40	37.6	25	28	26.9
July-December.....	30	38	32.6	41	50	44.6	35	47	37.5	37	46	40.9	38	52	41.9	27	37	29.8
1917.																		
January-June.....	38	58	46.5	50	76	59.0	46	68	55.0	45	71	5.54	52	82	60.8	37	57	44.0
July-December.....	57	67	63.5	75	77	76.7	67	80	75.0	71	78	75.3	80	85	82.6	56	64	60.3
1918.																		
January-June.....	61	67	65.0	76	78	76.8	76	78	76.8	75	79	77.4	83	90	85.9	61	64	63.0
July-December.....	61	67	63.5	76	78	76.7	77	78	77.7	.....	.....	.....	87	90	89.0	61	64	62.7
1919.																		
January.....	53	60	56.5	61	80	70.2	67	70	69.0	65	75	70.0	67	70	69.0	55	55	55.0
February.....	53	57	55.4	61	70	67.1	67	68	67.5	65	67	66.0	67	68	67.5	55	55	55.0
March.....	52	55	53.5	68	70	69.0	67	68	67.5	65	67	66.0	67	70	67.9	55	55	55.0
April.....	52	55	53.4	55	62	57.2	67	68	67.5	65	69	67.5	68	80	76.5	52	53	52.5
May.....	52	55	53.5	55	57	56.0	67	68	67.5	67	69	68.0	78	80	79.0	52	53	52.5
June.....	57	62	60.2	67	68	60.6	67	71	68.8	67	75	70.6	78	88	81.8	56	60	58.4
January-June.....	52	62	55.4	55	80	63.4	67	71	68.0	65	75	68.0	67	88	73.6	52	60	54.7
July.....	61	62	61.5	67	68	67.5	70	71	70.5	73	75	74.0	85	90	87.1	59	60	59.5
August.....	62	70	65.1	64	72	69.8	71	72	71.5	80	81	80.5	88	90	89.0	59	64	.....
September.....	68	70	69.0	70	72	70.2	71	72	71.5	80	81	80.5	88	90	89.0	63	64	63.0
October.....	68	70	69.0	66	68	66.8	71	72	71.5	80	81	80.5	88	98	91.5	63	64	63.5
November.....	68	72	70.2	66	68	66.9	74	75	72.5	80	85	82.0	95	102	98.3	63	67	64.7
December.....	70	72	71.0	67	68	67.5	71	76	75.2	83	85	84.3	100	102	101.0	66	68	67.2
July-December.....	61	72	65.1	66	72	68.2	70	76	72.1	73	85	80.3	85	102	92.6	59	68	63.3

Date.	Fine territory staple, scoured.			Fine medium territory clothing, scoured.			Texas 12 months, scoured.			Fine fall Texas, scoured.			Pulled A, super-scoured.			Pulled B, super-scoured.		
	Low.	High.	Average.	Low.	High.	Average.	Low.	High.	Average.	Low.	High.	Average.	Low.	High.	Average.	Low.	High.	Average.
1913.	Cts.	Cts.	Cts.	Cts.	Cts.	Cts.	Cts.	Cts.	Cts.	Cts.	Cts.	Cts.	Cts.	Cts.	Cts.	Cts.	Cts.	Cts.
January-June.....	55	67	59.5	49	59	53.8	52	65	58.4	45	50	47.6	48	58	52.8	43	54	47.0
July-December.....	51	56	53.9	46	50	48.3	50	53	51.8	41	46	44.4	42	52	48.4	36	45	40.7
1914.																		
January-June.....	51	63	57.2	46	55	51.2	50	62	55.5	41	50	45.0	43	53	49.3	36	43	40.7
July-December.....	60	65	62.7	55	57	56.0	55	62	59.1	42	50	47.2	50	55	51.6	40	56	45.9
1915.																		
January-June.....	62	75	70.0	55	68	63.8	56	75	67.7	42	60	55.3	56	68	61.5	57	74	62.8
July-December.....	70	75	72.6	63	68	65.0	65	70	67.9	54	57	55.8	60	66	63.6	55	65	61.4
1916.																		
January-June.....	73	85	79.8	65	75	71.7	67	77	72.6	53	55	54.5	63	68	66.2	59	66	62.4
July-December.....	82	112	93.0	75	87	78.8	77	100	84.9	55	78	60.8	65	85	70.0	60	80	67.5
1917.																		
January-June.....	110	175	135.9	85	135	107.5	100	175	127.0	75	120	88.8	83	150	114.5	75	140	104.0
July-December.....	172	185	180.0	135	160	153.6	165	175	169.3	115	150	135.0	145	165	157.5	130	150	142.2
1918.																		
January-June.....	180	190	183.5	155	160	157.5	168	175	171.6	140	155	147.9	145	165	160.9	140	155	148.6
July-December.....	180	185	181.7	.....	.....	.....	175	175	175.0	150	150	150.0	155	160	157.5	145	150	147.5

## SHEEP AND WOOL—Continued.

TABLE 254.—Wool: Wholesale price per pound in Boston, 1913-1919—Continued.

Date.	Fine territory staple, scoured.			Fine medium territory clothing, scoured.			Texas 12 months, scoured.			Fine fall Texas, scoured.			Pulled A, super-scoured.			Pulled B, super-scoured.		
	Low.	High.	Average.	Low.	High.	Average.	Low.	High.	Average.	Low.	High.	Average.	Low.	High.	Average.	Low.	High.	Average.
1919.	Cts.	Cts.	Cts.	Cts.	Cts.	Cts.	Cts.	Cts.	Cts.	Cts.	Cts.	Cts.	Cts.	Cts.	Cts.	Cts.	Cts.	Cts.
January.....	145	160	153.2	138	143	140.2	135	152	144.2	120	122	120.5	125	143	137.9	105	128	117.9
February.....	145	152	150.1	138	140	139.0	135	145	141.2	120	120	120.0	125	130	127.5	105	107	106.0
March.....	148	150	149.0	135	138	136.5	138	142	140.0	120	120	120.0	125	145	131.9	105	113	108.1
April.....	155	170	165.0	135	138	136.5	138	142	140.0	110	120	112.5	140	140	143.1	107	130	113.8
May.....	165	170	167.5	130	138	136.0	145	155	151.5	110	115	112.5	140	160	155.0	120	130	125.0
June.....	165	180	173.9	130	135	132.5	150	160	155.6	110	115	112.5	155	160	157.5	120	130	125.6
January-June.....	145	180	159.8	130	143	136.8	135	160	145.4	110	122	116.3	125	160	142.2	105	130	116.1
July.....	175	180	177.5	130	140	135.0	160	165	161.9	110	115	112.5	155	160	157.5	120	130	126.2
August.....	185	190	187.5	130	150	141.0	160	175	168.5	110	120	116.5	155	160	157.5	120	130	125.0
September.....	185	190	187.5	140	150	145.0	160	175	166.2	115	120	117.5	155	160	157.5	115	130	123.8
October.....	180	190	186.2	140	150	145.0	160	170	165.0	115	120	117.5	155	168	159.7	110	130	117.5
November.....	185	200	192.0	140	160	152.5	160	180	170.5	115	145	131.0	160	170	167.1	115	130	122.5
December.....	190	205	196.7	160	170	160.0	170	190	185.0	135	155	148.3	165	170	167.5	115	135	125.8
July-December.....	175	205	187.5	130	170	146.4	160	190	169.5	110	155	122.2	155	170	161.1	110	135	123.5

TABLE 255.—Wool: Wholesale price per pound, 1913-1919.

Date.	Boston.			Philadelphia.			St. Louis.		
	Ohio XX, washed.			Delaine, unwashed.			Best tub, washed.		
	Low.	High.	Average.	Low.	High.	Average.	Low.	High.	Average.
1913.	Cents.	Cents.	Cents.	Cents.	Cents.	Cents.	Cents.	Cents.	Cents.
January-June.....	27	32	29.4	.....	.....	.....	28	37	32.5
July-December.....	25	30	26.5	.....	.....	.....	28	35	28.7
1914.									
January-June.....	25½	29	27.0	22	27	23.6	28	33	29.6
July-December.....	27	31½	29.6	24	28	26.1	31	33	31.6
1915.									
January-June.....	29	34	32.0	28	32	30.0	31	41	37.6
July-December.....	32	32½	33.2	29	31	29.8	40	44	40.6
1916.									
January-June.....	32½	35	33.7	33	34	33.1	42	48	44.3
July-December.....	34	47	37.5	35	43	37.0	47	49	47.7
1917.									
January-June.....	46	68	55.0	44	74	.....	48	75	56.5
July-December.....	67	80	75.0	73	78	.....	75	85	81.4
1918.									
January-June.....	76	78	76.8	72	76	.....	83	90	86.0
July-December.....	77	78	77.7	(1)	(1)	(1)	90	91	90.9
1919.									
January.....	67	70	69.5	61	63	.....	.....	.....	.....
February.....	67	68	67.5	61	63	.....	70	77	73.5
March.....	67	68	67.5	62	64	.....	70	77	72.6
April.....	67	68	67.5	70	72	.....	60	75	67.1
May.....	67	68	67.5	73	75	.....	60	65	62.4
June.....	67	71	68.8	83	85	.....	65	75	73.4
January-June.....	67	71	68.0	61	85	.....	60	77	69.8
July.....	70	71	70.5	84	86	.....	75	80	76.2
August.....	71	72	71.5	84	86	.....	75	80	78.6
September.....	71	72	71.5	84	86	.....	75	75	75.0
October.....	71	72	71.5	.....	.....	.....	70	75	71.8
November.....	71	75	72.8	.....	.....	.....	70	70	70.5
December.....	74	76	75.0	.....	.....	.....	70	70	70.5
July-December.....	70	76	72.1	.....	.....	.....	70	80	73.8

1 No quotations.

SHEEP AND WOOL—Continued.

TABLE 256.—Wool: International trade, calendar years 1909–1913, 1917, and 1918.

["Wool" on this table includes: Washed, unwashed, scoured, and pulled wool; slipe, sheep's wool on skins (total weight of wool and skins taken); and all other animal fibers included in United States classification of wool. The following items have been considered as not within this classification: Corded, combed and dyed wool; flecks, goatskins with hair on, mill waste, noils, and tops. See "General note," Table 220.]

EXPORTS.  
[000 omitted.]

Country.	Average, 1909–1913.	1917 (preliminary).	1918 (preliminary).	Country.	Average, 1909–1913.	1917 (preliminary).	1918 (preliminary).
<i>From—</i>	<i>Pounds.</i>	<i>Pounds.</i>	<i>Pounds.</i>	<i>From—</i>	<i>Pounds.</i>	<i>Pounds.</i>	<i>Pounds.</i>
Algeria.....	19,871	4,764	10,269	New Zealand.....	194,801	178,289	108,725
Argentina.....	328,204	298,773	256,613	Persia.....	10,023	.....	.....
Australia.....	676,679	321,370	.....	Peru.....	9,333	15,248	.....
Belgium.....	196,440	.....	.....	Russia.....	32,406	.....	.....
British India.....	56,496	44,479	41,501	Spain.....	28,505	18,361	8,444
British South Africa.....	164,644	.....	.....	United Kingdom.....	42,027	6,996	2,347
Chile.....	28,223	29,734	.....	Uruguay.....	139,178	.....	.....
China.....	42,684	51,564	49,195	Other countries.....	67,233	.....	.....
France.....	84,973	10,524	907				
Germany.....	42,817	.....	.....	Total.....	2,190,899	.....	.....
Netherlands.....	26,362	.....	.....				

IMPORTS.

<i>Into—</i>				<i>Into—</i>			
Austria-Hungary.....	63,942	.....	.....	Russia.....	106,184	.....	.....
Belgium.....	300,367	.....	.....	Sweden.....	7,267	2,951	.....
British India.....	23,721	29,513	29,495	Switzerland.....	11,211	19,363	7,959
Canada.....	7,794	11,741	19,394	United Kingdom.....	550,931	636,195	441,687
France.....	601,628	13,426	89,661	United States.....	203,298	420,995	453,727
Germany.....	481,988	.....	.....	Other countries.....	58,275	.....	.....
Japan.....	10,223	47,305	49,590				
Netherlands.....	31,991	.....	.....	Total.....	2,458,820	.....	.....

SWINE.

TABLE 257.—Swine: Number and value on farms in the United States, 1867–1920.

NOTE.—Figures in italics are census returns; figures in roman are estimates of the Department of Agriculture. Estimates of numbers are obtained by applying estimated percentages of increase or decrease to the published numbers of the preceding year, except that a revised base is used for applying percentage estimates whenever new census data are available. It should also be observed that the census of 1910, giving numbers as of Apr. 15, is not strictly comparable with former censuses, which related to numbers June 1.

Jan. 1—	Number.	Price per head Jan. 1.	Farm value Jan. 1.	Jan. 1—	Number.	Price per head Jan. 1.	Farm value Jan. 1.
1867.....	24,694,000	\$4.03	\$99,637,000	1893.....	46,095,000	\$6.41	\$295,426,000
1868.....	24,317,000	3.29	79,976,000	1894.....	45,206,000	5.98	270,385,000
1869.....	23,316,000	4.65	108,431,000	1895.....	44,166,000	4.97	219,501,000
1870.....	26,751,000	5.80	155,108,000	1896.....	42,843,000	4.35	186,530,000
1870, census, June 1.....	<i>25,134,569</i>	.....	.....	1897.....	40,600,000	4.10	166,273,000
1871.....	29,458,000	5.61	165,312,000	1898.....	39,760,000	4.39	174,351,000
1872.....	31,796,000	4.01	127,453,000	1899.....	38,652,000	4.40	170,110,000
1873.....	32,632,000	3.67	119,632,000	1900.....	37,079,000	5.00	185,472,000
1874.....	30,861,000	3.98	122,695,000	1900, census, June 1.....	<i>62,868,041</i>	.....	.....
1875.....	28,062,000	4.80	134,581,000	1901 <sup>1</sup> .....	56,982,000	6.20	353,012,000
1876.....	25,727,000	6.00	154,251,000	1902.....	48,699,000	7.03	342,121,000
1877.....	28,077,000	5.66	158,873,000	1903.....	46,923,000	7.78	364,974,000
1878.....	32,262,000	4.85	156,577,000	1904.....	47,009,000	6.15	289,225,000
1879.....	34,766,000	3.18	110,508,000	1905.....	47,321,000	5.99	283,255,000
1880.....	34,034,000	4.28	145,782,000	1906.....	52,103,000	6.18	321,803,000
1880, census, June 1.....	<i>47,681,700</i>	.....	.....	1907.....	54,794,000	7.62	417,791,000
1881.....	36,248,000	4.70	170,535,000	1908.....	56,084,000	6.05	339,030,000
1882.....	44,122,000	5.97	263,543,000	1909.....	54,147,000	6.55	354,794,000
1883.....	43,270,000	6.75	291,951,000	1910.....	47,782,000	.....	.....
1884.....	44,201,000	5.57	246,301,000	1910, census, Apr. 15.....	<i>58,185,676</i>	9.17	533,309,000
1885.....	45,143,000	5.02	226,402,000	1911 <sup>1</sup> .....	65,620,000	9.37	615,170,000
1886.....	46,092,000	4.26	196,570,000	1912.....	65,410,000	8.00	523,328,000
1887.....	44,613,000	4.48	200,043,000	1913.....	61,178,000	9.86	603,109,000
1888.....	44,347,000	4.98	220,811,000	1914.....	58,933,000	10.40	612,951,000
1889.....	50,302,000	5.79	291,307,000	1915.....	64,618,000	9.87	637,479,000
1890.....	51,603,000	4.72	243,418,000	1916.....	67,766,000	8.40	569,573,000
1890, census, June 1.....	<i>57,409,583</i>	.....	.....	1917.....	67,503,000	11.75	792,898,000
1891.....	50,625,000	4.15	210,194,000	1918.....	70,978,000	19.54	1,387,261,000
1892.....	52,398,000	4.60	241,031,000	1919.....	74,584,000	22.02	1,642,598,000
				1920.....	72,909,000	19.01	1,386,212,000

<sup>1</sup> Estimates of numbers revised, based on census data.

## SWINE—Continued.

TABLE 258.—Swine: Number and value on farms Jan. 1, 1919 and 1920, by States.

State.	Number (thousands) Jan. 1—		Average price per head Jan. 1—		Farm value (thousands of dollars) Jan. 1—	
	1920	1919	1920	1919	1920	1919
Maine.....	116	110	\$24.50	\$24.00	\$2,842	\$2,640
New Hampshire.....	67	66	24.00	25.00	1,608	1,650
Vermont.....	120	120	22.50	23.00	2,700	2,760
Massachusetts.....	176	147	27.00	26.00	4,752	3,822
Rhode Island.....	16	15	30.00	28.00	480	420
Connecticut.....	100	83	27.50	27.00	2,750	2,241
New York.....	920	800	22.50	26.00	20,700	20,800
New Jersey.....	210	200	25.20	30.30	5,292	6,060
Pennsylvania.....	1,420	1,380	23.70	26.00	33,654	35,880
Delaware.....	73	71	19.00	19.50	1,387	1,384
Maryland.....	461	427	19.00	21.00	8,759	8,967
Virginia.....	1,127	1,094	15.00	18.00	16,905	19,692
West Virginia.....	443	439	18.00	18.50	7,974	8,122
North Carolina.....	1,592	1,546	20.00	21.00	31,840	32,466
South Carolina.....	1,088	1,056	21.50	21.00	23,392	22,176
Georgia.....	3,165	3,043	16.90	17.50	53,488	53,252
Florida.....	1,588	1,512	13.00	13.00	20,644	19,656
Ohio.....	4,351	4,266	19.20	21.80	83,539	92,999
Indiana.....	4,760	4,668	19.00	23.30	90,440	108,764
Illinois.....	5,323	5,724	20.50	25.00	109,122	143,100
Michigan.....	1,450	1,355	22.00	23.60	31,900	31,978
Wisconsin.....	2,236	2,070	23.50	26.50	52,546	54,855
Minnesota.....	2,951	2,784	24.00	28.50	70,824	79,344
Iowa.....	10,389	10,822	21.80	27.50	226,480	297,605
Missouri.....	4,305	4,629	16.50	18.50	71,032	85,636
North Dakota.....	428	475	21.00	24.70	8,988	11,732
South Dakota.....	1,730	1,730	21.50	27.50	37,195	47,575
Nebraska.....	3,366	3,825	20.90	26.50	70,349	101,362
Kansas.....	1,667	2,381	17.50	21.50	29,172	51,192
Kentucky.....	1,681	1,768	13.00	16.00	21,853	28,288
Tennessee.....	1,946	1,965	15.00	16.50	29,190	32,422
Alabama.....	2,201	2,223	12.80	17.00	28,173	37,791
Mississippi.....	2,396	2,282	14.50	16.00	34,742	36,512
Louisiana.....	1,512	1,575	14.30	15.20	21,622	23,940
Texas.....	2,356	2,320	19.50	17.00	45,942	39,440
Oklahoma.....	943	1,036	15.10	16.70	14,239	17,301
Arkansas.....	1,586	1,725	12.50	13.00	19,825	22,425
Montana.....	160	200	20.00	22.00	3,200	4,400
Wyoming.....	63	70	18.40	21.50	1,159	1,505
Colorado.....	382	406	18.00	22.00	6,876	8,932
New Mexico.....	83	87	21.80	19.00	1,809	1,653
Arizona.....	50	58	18.00	18.00	900	1,044
Utah.....	114	133	15.00	20.20	1,710	2,687
Nevada.....	32	40	14.00	18.00	448	720
Idaho.....	187	208	17.80	19.60	3,329	4,077
Washington.....	292	317	23.30	22.00	6,804	6,974
Oregon.....	314	330	19.50	19.10	6,123	6,303
California.....	973	1,003	18.00	18.00	17,514	18,054
United States.....	72,909	74,584	19.01	22.02	1,386,212	1,642,598

TABLE 259.—Hogs: Farm price per 100 pounds, 1910-1919.

Date.	1919	1918	1917	1916	1915	1914	1913	1912	1911	1910	Average.
Jan. 15.....	\$15.69	\$15.26	\$9.16	\$6.32	\$6.57	\$7.45	\$6.77	\$5.74	\$7.44	\$7.76	\$8.82
Feb. 15.....	15.53	15.03	10.33	7.07	6.34	7.75	7.17	5.79	7.04	7.87	8.99
Mar. 15.....	16.13	15.58	12.32	7.86	6.33	7.80	7.62	5.94	6.74	8.93	9.52
Apr. 15.....	17.39	15.76	13.61	8.21	6.48	7.80	7.94	6.78	6.17	9.26	9.94
May 15.....	18.00	15.84	13.72	8.37	6.77	7.60	7.45	6.79	5.72	8.59	9.88
June 15.....	17.80	15.37	13.50	8.21	6.80	7.43	7.61	6.65	5.66	8.46	9.75
July 15.....	19.22	15.58	13.35	8.40	6.84	7.72	7.81	6.64	5.92	8.15	9.96
Aug. 15.....	19.30	16.89	14.24	8.61	6.61	8.11	7.79	7.11	6.54	7.78	10.30
Sept. 15.....	15.81	17.50	15.69	9.22	6.79	8.11	7.68	7.47	6.53	8.27	10.31
Oct. 15.....	13.88	16.50	16.15	8.67	7.13	7.43	7.60	7.70	6.09	8.08	9.93
Nov. 15.....	13.36	15.92	15.31	8.74	6.35	7.00	7.33	7.05	5.86	7.61	9.45
Dec. 15.....	12.66	15.82	15.73	8.76	6.02	6.67	7.16	6.89	5.72	7.16	9.26

SWINE—Continued.

TABLE 260.—Hogs (live): Wholesale price per 100 pounds, 1913–1919.

Date.	Cincinnati.			St. Louis.			Chicago.			Kansas City.			Omaha.		
	Packing, fair to good.			Mixed packers.			Mixed and packers.			Light to choice.			Heavy to light.		
	Low.	High.	Average.	Low.	High.	Average.	Low.	High.	Average.	Low.	High.	Average.	Low.	High.	Average.
1913.	Dols.	Dols.	Dols.	Dols.	Dols.	Dols.	Dols.	Dols.	Dols.	Dols.	Dols.	Dols.	Dols.	Dols.	Dols.
January-June.....	7.45	10.00	8.64	7.20	9.50	8.44	6.95	9.60	8.31	6.95	9.25	.....	6.70	9.05	8.16
July-December.....	7.60	9.60	8.58	7.25	9.50	8.46	7.15	9.65	8.20	7.20	9.25	.....	7.34	9.15	7.96
1914.															
January-June.....	8.00	9.15	8.61	7.75	8.95	8.49	7.60	9.00	8.37	7.55	8.80	.....	7.35	8.73	8.20
July-December.....	6.40	9.90	8.32	6.80	9.85	8.31	6.50	10.20	8.06	6.65	9.75	.....	6.50	9.35	7.89
1915.															
January-June.....	6.50	8.00	7.35	6.00	7.97	7.25	6.15	7.95	7.01	6.35	7.90	7.07	6.00	7.95	6.93
July-December.....	6.25	8.70	7.41	6.15	8.75	7.36	5.80	8.95	7.07	6.00	8.65	7.19	4.00	8.95	6.79
1916.															
January-June.....	6.40	10.25	8.84	6.00	10.25	9.01	6.45	10.30	8.97	6.25	10.05	8.84	6.00	9.90	8.65
July-December.....	7.35	11.40	10.06	8.90	11.50	10.17	8.50	11.60	9.94	7.75	11.00	9.71	8.50	11.10	9.74
1917.															
January-June.....	10.60	16.25	14.17	9.90	16.55	14.23	9.75	16.60	14.10	9.80	16.45	13.93	9.40	16.20	13.74
July-December.....	15.40	19.15	17.00	15.00	19.80	17.32	14.00	20.00	16.78	14.50	19.65	16.78	14.00	19.60	16.85
1918.															
January-June.....	16.25	18.25	17.22	14.00	18.20	16.64	15.00	18.25	16.99	15.00	17.75	16.61	15.00	17.50	16.51
July-December.....	14.50	20.25	17.90	14.00	20.75	18.39	14.00	20.40	17.79	14.50	20.65	18.12	15.25	20.40	17.87
1919.															
January.....	14.50	18.00	16.58	12.50	18.05	17.16	15.75	17.85	17.06	16.25	17.75	16.94	16.00	17.65	17.26
February.....	14.00	18.50	16.84	12.25	18.50	17.45	16.25	18.00	17.18	16.25	18.00	17.14	16.00	17.75	17.06
March.....	15.00	19.75	17.47	16.00	20.00	18.90	16.65	19.90	18.86	16.25	19.75	17.98	16.50	19.50	18.28
April.....	17.00	20.75	19.16	18.50	21.05	20.31	19.80	21.15	20.49	17.50	21.00	19.43	19.00	20.85	20.04
May.....	18.00	21.00	19.45	18.50	21.20	20.45	20.00	21.55	20.69	20.00	21.55	20.69	19.15	20.80	20.21
June.....	18.50	21.25	20.06	19.25	21.85	20.56	19.65	21.50	20.52	19.65	21.50	20.52	19.80	21.10	20.46
January-June....	14.00	21.25	18.26	12.25	21.85	19.14	15.75	21.55	19.13	16.25	21.55	18.78	16.00	21.10	18.88
July.....	20.50	23.25	21.68	20.35	23.50	22.37	21.00	23.50	21.72	19.80	23.10	21.48	20.35	22.85	21.62
August.....	20.00	23.25	21.47	19.25	23.55	21.73	16.25	23.50	20.65	15.00	23.20	20.37	15.50	22.50	19.97
September.....	14.50	20.00	17.72	16.00	20.50	17.76	12.25	18.00	15.29	14.00	19.75	16.53	14.00	19.75	16.82
October.....	11.50	17.25	14.12	12.50	17.35	14.77	13.00	19.40	16.40	11.00	16.85	13.94	11.75	15.35	14.23
November.....	12.50	15.00	13.69	12.25	15.60	14.51	11.50	20.50	14.34	12.00	15.45	13.72	11.75	15.35	14.23
December.....	12.00	14.25	13.64	12.50	15.10	13.91	11.75	14.60	13.50	11.00	15.00	13.30	12.25	14.75	13.33
July-December..	11.50	23.25	17.05	12.25	23.55	18.89	11.50	23.50	16.99	11.00	23.20	16.56	11.75	22.85	14.33

## LIVE STOCK VALUES.

TABLE 261.—Aggregate live-stock value comparisons, 1919, 1920, and average 1914-1918.

[Farm values Jan. 1, in millions of dollars, i. e., 000,000 omitted; States arranged according to 1920 rank in value of meat animals.]

States.	Cattle, hogs, and sheep.			Horses and mules.			Total (cattle, hogs, sheep, horses, and mules).			Rank in aggregate value.	
	1920	1919	Av., 1914-1918.	1920	1919	Av., 1914-1918.	1920	1919	Av., 1914-1918.	1920	1919
Iowa.....	497	584	342	143	154	178	640	738	520	1	1
Texas.....	348	287	259	225	182	174	572	468	434	2	3
Illinois.....	294	325	187	152	165	173	446	490	360	3	2
Missouri.....	247	261	169	132	139	135	379	400	304	4	5
Wisconsin.....	299	263	177	74	76	89	374	339	266	5	9
Ohio.....	266	264	159	99	99	112	364	363	271	6	7
Nebraska.....	256	304	202	88	103	109	344	407	312	7	4
Kansas.....	215	262	175	122	138	136	336	400	311	8	6
Minnesota.....	249	249	139	86	94	102	335	343	241	9	8
New York.....	235	200	145	80	80	87	315	280	232	10	11
Indiana.....	206	225	124	95	97	104	301	322	228	11	10
Pennsylvania.....	173	158	104	75	77	84	248	234	188	12	13
Michigan.....	175	158	105	61	70	86	236	228	192	13	14
California.....	189	177	124	45	47	56	234	225	180	14	15
South Dakota.....	155	184	103	60	68	73	215	252	176	15	12
Oklahoma.....	107	121	91	95	93	93	202	214	184	16	16
Georgia.....	105	104	49	97	89	68	202	193	117	17	17
Mississippi.....	88	89	42	78	73	56	167	162	97	18	22
Kentucky.....	93	103	60	72	75	68	165	178	128	19	18
Tennessee.....	82	84	46	79	80	70	160	165	116	20	21
Colorado.....	117	134	83	37	41	35	153	175	118	21	19
Alabama.....	77	88	41	74	68	51	151	156	92	22	24
North Carolina.....	73	67	35	73	66	55	146	134	89	23	26
North Dakota.....	73	81	54	68	80	87	141	161	141	24	23
Virginia.....	87	84	45	48	49	46	135	133	91	25	27
Arkansas.....	63	67	41	69	64	52	132	130	92	26	28
Montana.....	94	126	83	31	49	41	126	174	124	27	20
Louisiana.....	69	65	35	50	45	34	120	109	70	28	30
New Mexico.....	95	89	64	18	17	15	113	106	80	29	31
South Carolina.....	51	47	21	62	56	41	113	102	61	30	33
Oregon.....	85	82	54	25	28	29	110	110	83	31	29
Wyoming.....	81	126	75	12	19	15	93	145	90	32	25
Idaho.....	72	81	52	21	25	24	93	106	75	33	32
Arizona.....	72	69	46	10	11	10	82	80	56	34	34
Washington.....	48	45	33	30	30	32	78	75	65	35	35
West Virginia.....	55	53	35	21	21	23	76	74	58	36	36
Florida.....	58	52	27	16	15	12	74	67	39	37	38
Utah.....	53	60	37	11	12	13	64	72	50	38	37
Maryland.....	34	32	20	20	21	22	55	53	41	39	39
Nevada.....	44	48	33	5	5	6	49	53	39	40	40
Vermont.....	36	30	23	12	12	12	48	42	35	41	41
New Jersey.....	30	25	17	14	13	14	43	39	32	42	42
Maine.....	24	22	15	16	17	17	40	39	31	43	43
Massachusetts.....	26	23	16	8	8	10	34	31	25	44	44
Connecticut.....	19	17	12	7	7	7	26	24	19	45	45
New Hampshire.....	14	13	10	6	6	6	20	19	16	46	46
Delaware.....	7	6	4	3	4	4	10	10	8	47	47
Rhode Island.....	3	3	2	1	1	1	5	4	4	48	48
United States ..	5,839	6,040	3,815	2,727	2,788	2,765	8,566	8,828	6,580	.....	.....



LIVE STOCK PRICES.

TABLE 262.—Prices of live stock by ages or classes, United States, 1914-1920.

Cattle.	1920	1919	1918	1917	1916	1915	1914
Horses:							
Under 1 year old.....	\$39.06	\$42.62	\$45.20	\$45.17	\$44.30	\$45.36	\$47.95
1 and under 2 years.....	61.39	65.94	70.21	70.21	69.02	70.62	74.87
2 years and over.....	104.04	108.17	114.30	112.64	111.28	113.10	119.77
Mules:							
Under 1 year old.....	60.52	59.14	57.61	53.98	51.47	51.80	57.45
1 and under 2 years.....	91.92	89.14	86.32	80.28	76.69	76.46	83.87
2 years and over.....	160.52	147.65	139.88	128.17	123.59	121.46	133.76
Other cattle (than milk):							
Under 1 year.....	24.41	24.97	23.44	20.71	19.08	19.06	17.84
1 and under 2 years.....	40.99	41.74	38.63	33.93	31.48	31.21	29.77
2 years and over.....	59.01	60.41	55.62	48.63	45.81	45.92	42.77
Sheep:							
Under 1 year.....	8.09	8.82	9.06	5.63	4.13	3.62	3.22
Ewes 1 year and over.....	11.10	12.44	12.70	7.48	5.35	4.59	4.09
Wethers 1 year and over....	9.81	11.02	11.26	6.78	5.02	4.48	4.06
Rams.....	21.52	21.90	20.84	13.62	10.32	9.01	8.49

LIVE STOCK MARKETINGS.

TABLE 263.—Yearly marketings of live stock at principal markets, 1900-1919.

The combined receipts and shipments of cattle, hogs, and sheep, at Chicago, Kansas City, Omaha, St. Louis, Sioux City, St. Joseph, and St. Paul yearly since 1900 were as follows:

Year.	Cattle.		Hogs.		Sheep.	
	Receipts.	Shipments.	Receipts.	Shipments.	Receipts.	Shipments.
1900.....	7,179,344	3,793,308	18,573,177	5,336,826	7,061,466	2,500,686
1901.....	7,708,839	3,888,460	20,339,864	5,772,717	7,798,359	2,712,866
1902.....	8,375,408	4,292,705	17,289,427	4,130,675	9,177,050	3,561,060
1903.....	8,878,789	4,490,748	16,780,250	4,233,572	9,680,692	3,983,310
1904.....	8,690,699	4,552,554	17,778,827	5,254,545	9,604,812	4,203,834
1905.....	9,202,083	4,964,753	18,988,933	5,614,306	10,572,259	4,725,872
1906.....	9,373,825	5,026,689	19,223,792	5,440,333	10,864,437	5,046,366
1907.....	9,590,710	5,360,790	19,544,617	5,993,069	9,857,877	4,549,000
1908.....	8,827,360	4,936,731	22,863,701	7,288,403	9,833,640	4,489,295
1909.....	9,189,312	5,181,446	18,420,012	6,381,667	10,284,858	4,172,388
1910.....	9,116,687	5,122,984	14,853,472	4,628,760	12,366,375	6,013,215
1911.....	8,629,109	4,805,766	19,926,547	6,418,246	13,521,492	5,891,034
1912.....	8,061,494	4,318,648	19,771,825	6,096,906	13,733,980	5,369,402
1913.....	7,904,552	4,596,085	19,924,331	6,414,815	14,037,830	6,046,260
1914.....	7,182,239	3,933,663	18,272,091	5,816,069	13,272,491	5,331,449
1915.....	7,963,591	3,944,152	21,031,405	6,823,983	11,160,246	4,370,504
1916.....	9,319,851	4,713,700	25,345,802	8,264,752	11,639,022	4,640,615
1917.....	11,241,038	5,676,015	20,945,301	7,151,995	10,017,353	4,534,489
1918.....	12,936,068	5,388,838	25,461,514	7,111,935	12,064,416	5,749,835
1919.....	12,151,920	5,316,761	25,280,245	5,941,663	14,307,503	5,714,471

Figures for 1900-1909, inclusive, were taken from the Monthly Summary of Commerce and Finance of the United States; 1910 and subsequently from official reports of the stockyards in the cities mentioned. The receipts of calves (not included in "Cattle") at the stockyards of Chicago, Kansas City, St. Joseph, St. Paul, and Sioux City, combined, were about 1,589,491 in 1919, 1,361,787 in 1918, 1,180,063 in 1917, 918,778 in 1916, 726,145 in 1915, 664,000 in 1914, 741,000 in 1913, about 910,000 in 1912, 975,000 in 1911, 981,000 in 1910, and 869,000 in 1909.

THE FEDERAL MEAT INSPECTION.

Some of the principal facts connected with the Federal meat inspection as administered by the Bureau of Animal Industry are shown in the following tables. The figures cover the annual totals beginning with the fiscal year 1907, which was the first year of operations under the meat-inspection law now in force. The data given comprise the number of establishments at which inspection is conducted; the number of animals of each species inspected at slaughter; the number of each species condemned, both wholly and in part, and the percentage condemned of each species and of all animals; the quantity of meat products prepared or processed under Federal supervision, and the quantity and percentage of the latter condemned.

## THE FEDERAL MEAT INSPECTION—Continued.

Further details of the Federal meat inspection are published each year in the Annual Report of the Chief of the Bureau of Animal Industry.

TABLE 264.—Number of establishments inspected and total number of animals slaughtered under Federal inspection annually, 1907 to 1919.

Year ending June 30—	Estab-lish-ments.	Cattle.	Calves.	Swine.	Sheep.	Goats.	All animals.
1907.....	708	7,621,717	1,763,574	31,815,900	9,681,876	52,149	50,935,216
1908.....	787	7,116,275	1,995,487	35,113,077	9,702,545	45,953	53,973,337
1909.....	876	7,325,337	2,046,711	35,427,931	10,802,903	69,193	55,672,075
1910.....	919	7,962,189	2,295,099	27,656,021	11,149,937	115,811	49,179,057
1911.....	936	7,781,030	2,219,908	29,916,363	13,005,502	54,145	52,976,948
1912.....	940	7,532,005	2,242,929	34,966,378	14,208,724	63,983	59,014,019
1913.....	910	7,155,816	2,098,484	32,287,538	14,724,465	56,556	56,322,859
1914.....	893	6,724,117	1,814,904	33,289,705	14,958,834	121,827	56,909,387
1915.....	896	6,964,402	1,735,902	36,247,958	12,909,089	165,533	58,022,884
1916.....	875	7,404,288	2,048,022	40,482,799	11,985,926	180,356	62,101,391
1917.....	833	9,299,489	2,679,745	40,210,847	11,343,418	174,649	63,708,148
1918.....	884	10,938,287	3,323,077	35,449,247	8,769,498	149,503	58,629,612
1919.....	895	11,241,991	3,674,227	44,398,389	11,268,370	125,660	70,708,637

TABLE 265.—Condemnations of animals at slaughter, 1907-1919.

Year ended June 30—	Cattle.			Calves.			Swine.		
	Whole.	Part.	Per cent. <sup>1</sup>	Whole.	Part.	Per cent. <sup>1</sup>	Whole.	Part.	Per cent. <sup>1</sup>
1907.....	27,933	93,174	1.58	6,414	245	0.38	105,879	436,161	1.70
1908.....	33,216	67,482	1.41	5,854	396	.31	127,933	636,589	2.18
1909.....	35,103	99,739	1.84	8,213	409	.42	86,912	799,300	2.50
1910.....	42,426	122,167	2.07	7,524	500	.35	52,439	726,829	2.82
1911.....	39,402	123,969	2.10	7,654	781	.38	59,477	877,528	3.13
1912.....	50,363	134,783	2.46	8,927	1,212	.45	129,002	323,992	1.30
1913.....	50,775	130,139	2.53	9,216	1,377	.50	173,937	373,993	1.70
1914.....	48,356	138,085	2.77	6,696	1,234	.44	204,942	422,275	1.88
1915.....	52,496	178,409	3.32	5,941	1,750	.44	213,905	464,217	1.87
1916.....	57,579	188,915	3.33	6,681	1,988	.42	195,107	546,290	1.83
1917.....	78,706	249,637	3.53	10,112	2,927	.49	158,480	528,288	1.71
1918.....	68,156	178,940	2.26	8,109	2,308	.31	113,079	347,006	1.30
1919.....	59,549	166,791	2.01	9,202	2,479	.32	128,805	433,433	1.27

Year ended June 30—	Sheep.			Goats.			All animals.		
	Whole.	Part.	Per cent. <sup>1</sup>	Whole.	Part.	Per cent. <sup>1</sup>	Whole.	Part.	Per cent. <sup>1</sup>
1907.....	9,524	296	0.10	42	.....	0.08	149,792	529,876	1.33
1908.....	8,090	198	.09	33	1	.07	175,126	704,666	1.63
1909.....	10,747	179	.10	82	1	.12	141,057	899,628	1.87
1910.....	11,127	24,714	.32	226	1	.19	113,742	874,211	2.01
1911.....	10,789	7,394	.14	61	.....	.11	117,383	1,009,672	2.13
1912.....	15,402	3,871	.13	84	1	.13	203,778	463,859	1.13
1913.....	16,657	939	.12	76	1	.14	250,661	506,449	1.34
1914.....	20,563	1,564	.15	746	8	.62	281,303	563,166	1.48
1915.....	17,611	298	.14	653	14	.40	290,606	644,688	1.61
1916.....	15,057	1,007	.13	663	161	.46	275,087	738,361	1.63
1917.....	16,749	437	.15	1,349	42	.80	265,396	781,331	1.64
1918.....	12,564	227	.15	419	1	.28	202,327	528,482	1.25
1919.....	14,371	330	.13	318	17	.27	212,245	603,050	1.15

<sup>1</sup> Includes both whole and parts. It should be understood that the parts here recorded are primal parts; a much larger number of less important parts, especially in swine, are condemned in addition.

THE FEDERAL MEAT INSPECTION—Continued.

TABLE 266.—Quantity of meat and meat food products prepared, and quantity and percentage condemned, under Federal supervision annually, 1907 to 1919.

Year ended June 30—	Prepared or processed.	Condemned.	Percentage condemned.	Year ended June 30—	Prepared or processed.	Condemned.	Percentage condemned.
	<i>Pounds.</i>	<i>Pounds.</i>	<i>Per cent.</i>		<i>Pounds.</i>	<i>Pounds.</i>	<i>Per cent.</i>
1907.....	4,464,213,208	14,874,587	0.33	1914.....	7,033,295,975	19,135,469	0.27
1908.....	5,958,298,364	43,344,206	.73	1915.....	7,533,070,002	18,780,122	.25
1909.....	6,791,437,032	24,679,754	.36	1916.....	7,474,242,192	17,897,367	.24
1910.....	6,223,964,593	19,031,808	.31	1917.....	7,663,633,957	19,857,270	.26
1911.....	6,934,233,214	21,073,577	.31	1918.....	7,905,184,924	17,543,184	.22
1912.....	7,279,558,956	18,096,587	.25	1919.....	9,169,042,049	30,323,320	.33
1913.....	7,094,809,809	18,851,930	.27				

The principal items in Table 266, in the order of magnitude, are: Cured pork, lard sausage, canned beef, lard substitutes, and oleo products. The list includes a large number of less important items.

It should be understood that the above products are entirely separate and additional to the carcass inspection at time of slaughter. They are, in fact, reinspections of such portions of the carcass as have subsequently undergone some process of manufacture

TABLE 267.—Quantity of meat and meat food products imported, and quantity and percentage condemned or refused entry, 1914 to 1919.

Year ended June 30—	Total imported.	Condemned.	Refused entry.	Percentage condemned or refused.
	<i>Pounds.</i>	<i>Pounds.</i>	<i>Pounds.</i>	<i>Per cent.</i>
1914 (9 months).....	197,389,348	551,859	.....	0.28
1915.....	245,023,437	2,020,291	70,454	.85
1916.....	110,514,476	298,276	113,907	.37
1917.....	29,138,996	382,160	14,611	1.36
1918.....	59,025,484	989,916	414,452	2.38
1919.....	179,911,142	340,358	501,802	.47

## IMPORTS AND EXPORTS OF AGRICULTURAL PRODUCTS. <sup>1</sup>

[Compiled in the Bureau of Crop Estimates from reports of the foreign commerce and navigation of the United States, U. S. Department of Commerce.]

TABLE 268.—*Agricultural imports of the United States during the 3 years ending June 30, 1919.*

Article imported.	Year ending June 30—					
	1917		1918		1919 (preliminary).	
	Quantity.	Value.	Quantity.	Value.	Quantity.	Value.
<b>ANIMAL MATTER.</b>						
Animals, live:						
Cattle—						
For breeding purposes,						
.....number <sup>2</sup>	374, 826	\$13, 021, 259	293, 719	\$17, 852, 176	440, 399	\$36, 995, 921
Horses—						
For breeding purposes,						
.....number <sup>2</sup>	2, 684	1, 056, 033	879	706, 744	793	308, 759
Other.....do.....	9, 900	832, 270	4, 232	480, 699	3, 210	441, 505
Total horses....do....	12, 584	1, 888, 303	5, 111	1, 187, 443	4, 003	750, 264
Sheep—						
For breeding purposes,						
.....number <sup>2</sup>	160, 422	856, 645	177, 681	1, 979, 746	163, 283	1, 914, 473
Swine.....number..	5, 669	113, 457	12, 696	324, 182	24, 236	871, 614
All other, including fowls.		723, 195		614, 831		442, 494
Total live animals....		16, 602, 859		21, 958, 378		40, 924, 766
Beeswax.....pounds..	2, 685, 982	894, 318	1, 826, 618	632, 356	2, 126, 942	791, 662
Dairy products:						
Butter.....do.....	523, 573	192, 767	1, 805, 925	619, 303	4, 131, 469	1, 869, 132
Cheese.....do.....	14, 481, 514	4, 465, 633	9, 839, 305	4, 089, 027	2, 442, 306	1, 099, 284
Milk and cream—						
Fresh.....gallons..					2, 591, 553	1, 318, 885
Condensed....pounds..		2, 412, 713		3, 672, 063	20, 183, 723	2, 042, 528
Total dairy products		7, 071, 113		8, 380, 393		6, 329, 829
Eggs.....dozen..	1, 110, 322	268, 286	1, 619, 069	483, 636	847, 671	233, 003
Egg albumen.....pounds..	(3)	(3)	(3)	(3)	2, 952, 911	1, 475, 384
Egg yolks or frozen eggs,						
pounds.....	10, 317, 774	1, 732, 948	14, 597, 503	4, 057, 417	9, 085, 449	3, 143, 190
Feathers and downs, crude:						
Ostrich.....pounds..	(3)	534, 921	(3)	746, 709	165, 506	1, 007, 732
Other.....do.....	(3)	944, 295	(3)	1, 212, 471	1, 418, 704	427, 771
Fibers, animal:						
Silk—						
Cocoons.....pounds..	62, 056	54, 995	251, 447	319, 349	734, 710	307, 155
Raw, or as reeled from						
the cocoon..pounds..	33, 868, 885	156, 085, 649	34, 846, 197	183, 076, 241	34, 321, 030	202, 643, 259
Waste.....do.....	6, 420, 482	4, 431, 164	8, 583, 344	7, 229, 176	15, 012, 903	14, 567, 070
Total silk.....do....	40, 351, 423	160, 571, 808	43, 680, 988	190, 624, 766	50, 068, 643	217, 517, 484
Wool, and hair of the camel, goat, alpaca, and like animals—						
Class 1, clothing,						
pounds.....	279, 481, 501	101, 502, 941	303, 868, 940	165, 026, 343	327, 944, 568	182, 532, 037
Class 2, combing						
pounds.....	17, 055, 953	6, 723, 737	13, 953, 957	8, 583, 978	2, 383, 551	1, 443, 002
Class 3, carpet. pounds..	67, 672, 671	19, 814, 386	58, 994, 662	23, 867, 365	84, 178, 453	36, 387, 702
Hair of the Angora goat,						
alpaca, etc..pounds..	8, 162, 093	3, 096, 106	2, 312, 375	1, 068, 225	7, 908, 092	4, 047, 321
Total wool.....	372, 372, 218	131, 137, 170	379, 129, 934	198, 545, 911	422, 414, 664	224, 410, 062
Total animal fibers,						
pounds.....	412, 723, 641	291, 708, 978	422, 810, 922	389, 170, 677	472, 483, 307	441, 927, 546

<sup>1</sup> Forest products come within the scope of the Department of Agriculture and are therefore included in alphabetical order in these tables.

<sup>2</sup> Including all imported free of duty.

<sup>3</sup> Not stated.

TABLE 268.—Agricultural imports of the United States during the 3 years ending June 30, 1919—Continued.

Article imported.	Year ending June 30—					
	1917		1918		1919 (preliminary).	
	Quantity.	Value.	Quantity.	Value.	Quantity.	Value.
<b>ANIMAL MATTER—contd.</b>						
Gelatin.....pounds..	1,114,667	\$359,076	365,586	\$133,057	74,933	\$44,811
Glue and glue size....do....	6,265,597	928,000	2,048,543	348,241	554,217	195,919
Honey.....gallons..	427,650	289,317	591,683	845,082	321,823	427,683
<b>Packing-house products:</b>						
Blood, dried....pounds..	(1)	389,455	(1)	462,703	13,880,876	518,630
Bones, hoofs, and horns, pounds.....	(1)	987,544	(1)	1,374,546	28,113,123	475,202
<b>Bristles—</b>						
Crude, unsorted, pounds.....	129,460	52,536	33,483	79,131	45,950	64,974
Sorted, bunched, or prepared....pounds..	4,026,539	4,381,411	3,936,667	4,894,046	4,177,019	5,649,025
Total bristles.do....	4,155,999	4,433,947	3,970,150	4,973,177	4,222,969	5,713,999
Grease.....		861,973	26,128,588	3,161,233	28,459,875	2,863,910
<b>Hair—</b>						
Horse.....pounds..	6,337,754	2,224,576	3,955,109	1,284,174	3,295,863	1,166,306
Other animal....do....	6,771,033	818,298	4,028,839	550,306	3,988,273	326,387
Hide cuttings and other glue stock....pounds..	33,639,707	1,452,273	21,710,205	936,393	8,833,386	518,266
<b>Hides and skins, other than furs—</b>						
Buffalo hides, dry, pounds.....	27,095,228	6,125,219	10,497,860	2,808,995	9,514,989	2,175,007
Cabretta, or kid skins, pounds.....	(1)	(1)	(1)	(1)	4,026	949
<b>Calfskins—</b>						
Dry.....pounds..	33,936,381	11,062,856	8,893,766	3,699,479	11,602,385	5,967,424
Green or pickled, pounds.....	12,399,814	4,530,193	4,267,549	1,577,122	9,046,040	4,174,541
<b>Cattle hides—</b>						
Dry.....pounds..	161,236,620	48,714,500	76,655,271	23,929,479	33,181,575	9,585,052
Green or pickled, pounds.....	225,363,408	51,236,153	190,844,499	43,820,645	220,695,155	50,739,610
<b>Goatskins—</b>						
Dry.....pounds..	92,425,345	51,777,399	56,735,829	29,741,959	78,159,320	48,015,567
Green or pickled, pounds.....	13,214,962	3,642,410	10,197,108	1,989,466	10,845,208	3,210,822
<b>Horse and ass skins—</b>						
Dry.....pounds..	12,185,138	3,731,858	2,698,857	637,286	2,762,086	598,205
Green or pickled, pounds.....	15,485,233	2,459,969	6,360,178	931,353	3,550,613	484,437
Kangaroo.....pounds..	958,629	721,754	670,685	709,263	1,053,490	986,137
<b>Sheepskins<sup>2</sup>—</b>						
Dry.....pounds..	55,283,868	17,954,483	32,238,584	11,833,646	26,464,459	10,183,506
Green or pickled, pounds.....	40,446,730	11,626,832	23,230,331	7,272,342	35,431,056	11,297,085
Other.....pounds..	10,176,141	2,779,983	9,226,176	2,677,317	5,831,324	1,870,202
Total hides and skins, pounds.....	700,207,497	216,363,609	432,516,693	131,628,352	448,141,726	149,288,544
<b>Meat—</b>						
<b>Cured—</b>						
Bacon and hams, pounds.....	190,293	46,394	260,031	79,162	4,056,812	1,187,419
Meat prepared or pre- served....pounds..	(1)	981,212	(1)	7,320,101	135,878,504	37,779,982
Sausage, bologna, pounds.....	682	274	15,056	5,664	16,166	6,450
<b>Fresh—</b>						
Beef and veal, pounds.....	15,217,118	1,613,090	25,451,655	3,651,860	36,670,374	6,626,517
Mutton and lamb, pounds.....	4,684,131	555,646	2,007,601	267,948	4,542,317	938,628
Pork.....pounds..	1,651,227	280,795	1,847,733	373,301	2,744,412	645,599
Other, including meat extracts...pounds..	(1)	3,773,082	(1)	15,157,317	6,813,532	1,423,938
Total meat.....	(1)	7,250,493	(1)	26,855,353	190,722,117	48,608,533

<sup>1</sup>Not stated.<sup>2</sup> Except sheepskins with the wool on.

TABLE 268.—Agricultural imports of the United States during the 3 years ending June 30, 1919—Continued.

Article imported.	Year ending June 30—					
	1917		1918		1919 (preliminary).	
	Quantity.	Value.	Quantity.	Value.	Quantity.	Value.
ANIMAL MATTER—contd.						
Packing-house products—						
Continued.						
Oleo stearin..... pounds..	1, 113, 277	\$114, 640	6, 575, 379	\$1, 118, 422	1, 601, 814	\$314, 308
Rennets..... do.....		13, 154	(1)	62, 173	40, 905	97, 964
Sausage casings..... do.....		4, 219, 235	(1)	3, 631, 025	8, 353, 018	4, 098, 714
Tallow..... do.....	(1)	(1)	(1)	(1)	10, 808, 742	1, 408, 007
Total packing-house products.....	(1)	239, 129, 197	(1)	176, 037, 857	750, 462, 687	215, 398, 770
Total animal matter.....		560, 463, 308		604, 006, 274		712, 328, 066
VEGETABLE MATTER.						
Argols or wine lees, pounds..	23, 925, 808	3, 824, 882	30, 267, 382	5, 443, 628	32, 228, 216	5, 281, 794
Breadstuffs. (See Grain and grain products.)						
Broom corn..... long tons..	30	4, 743	2, 482	474, 225	142	42, 501
Cocoa and chocolate:						
Cocoa—						
Crude, leaves and shells of..... pounds..	338, 653, 876	39, 834, 279	399, 040, 401	41, 277, 479	313, 037, 419	35, 953, 990
Chocolate..... do.....	1, 829, 521	553, 139	271, 877	94, 899	157, 309	55, 950
Total cocoa and chocolate..... pounds..	340, 483, 397	40, 387, 418	399, 312, 278	41, 372, 378	313, 194, 728	36, 009, 940
Coffee..... do.....	1, 319, 870, 802	133, 184, 000	1, 143, 890, 889	103, 058, 536	1, 046, 029, 274	143, 089, 619
Coffee substitutes:						
Chicory root—						
Roasted, ground, or otherwise prepared, pounds.....	353, 271	37, 383	5, 381	598	25	8
Fibers, vegetable:						
Cotton..... pounds..	147, 061, 635	40, 429, 526	103, 325, 647	36, 020, 483	103, 592, 194	37, 633, 612
Flax..... long tons..	7, 918	4, 236, 232	5, 607	5, 818, 473	8, 659	7, 715, 520
Hemp..... do.....	9, 635	2, 487, 477	6, 813	2, 748, 376	2, 410	1, 605, 664
Istle, or Tampico fiber, long tons.....	32, 680	2, 913, 414	30, 810	2, 972, 891	25, 118	3, 020, 174
Jute and jute butts, long tons.....	112, 695	9, 855, 196	78, 312	7, 213, 641	53, 218	6, 295, 690
Kapoc..... long tons..	6, 861	1, 671, 245	4, 680	1, 239, 475	9, 904	3, 080, 946
Manila..... do.....	76, 765	17, 274, 455	86, 220	30, 434, 824	67, 844	25, 331, 365
New Zealand flax.. do....	7, 910	1, 718, 740	10, 478	3, 620, 959	11, 235	3, 447, 749
Sisal grass..... do.....	143, 407	25, 931, 525	150, 164	51, 532, 666	153, 455	51, 621, 653
Other..... do.....	10, 747	1, 621, 474	16, 769	3, 461, 165	8, 160	1, 753, 319
Total vegetable fibers.....		108, 139, 284		145, 062, 953		141, 505, 692
Forest products:						
Cinchona bark.. pounds..	2, 531, 397	685, 936	3, 273, 628	810, 775	3, 866, 158	803, 081
Cork wood or cork bark, pounds.....		3, 870, 389	(1)	3, 061, 827	26, 505, 971	1, 736, 102
Dyewoods, and extracts of—						
Dyewoods—						
Logwood.. long tons..	122, 794	4, 137, 400	52, 027	1, 066, 455	20, 871	412, 952
Other..... do.....	8, 895	189, 176	35, 449	951, 667	6, 639	137, 292
Total dyewoods, do....	131, 689	4, 326, 576	87, 476	2, 018, 122	27, 510	550, 244
Extracts and decoctions of..... pounds..	2, 500, 854	152, 619	4, 573, 925	219, 993	8, 268, 184	422, 289
Total dyewoods, and extracts of.....		4, 479, 195		2, 238, 115		972, 533

1 Not stated.

TABLE 268.—Agricultural imports of the United States during the 3 years ending June 30, 1919—Continued.

Article imported.	Year ending June 30—					
	1917		1918		1919 (preliminary).	
	Quantity.	Value.	Quantity.	Value.	Quantity.	Value.
VEGETABLE MATTER—con.						
Forest products—Contd.						
Gums—						
Arabic or Senegal, pounds.....	(1)	(1)	(1)	(1)	8,555,674	\$1,359,838
Camphor—						
Crude.....pounds..	6,884,950	\$2,101,239	3,638,384	\$1,451,050	2,622,792	1,389,768
Refined.....do....	4,263,815	1,972,351	1,189,932	819,431	1,500,357	2,072,082
Chicle.....do....	7,440,022	3,538,353	6,408,093	3,454,193	8,344,657	5,046,494
Copal, kauri, and damar.....pounds..	41,443,760	3,402,403	30,003,549	2,868,863	27,895,777	2,752,481
Gambier, or terra ja- ponica.....pounds..	10,133,625	859,873	8,964,832	955,352	5,909,382	654,211
India rubber, gutta- percha, etc.—						
Balata.....pounds..	3,287,445	1,649,452	2,449,881	1,278,610	1,238,852	593,633
Guayule gum..do....	2,854,372	764,484	4,307,539	1,341,095	2,990,253	761,060
Gutta-joolatong, or East Indian gum, pounds.....	23,376,389	1,044,022	17,475,863	975,816	11,363,283	1,199,216
Gutta-percha, pounds	2,021,794	332,223	1,151,312	147,323	4,151,085	710,510
India rubber...do....	333,373,711	189,328,674	389,599,015	202,800,392	402,471,531	157,928,132
Total india rubber, etc.....pounds..	364,913,711	193,118,855	414,983,610	206,543,236	422,215,004	161,192,551
Shellac.....do....	32,539,522	7,623,647	22,913,256	9,514,651	14,268,653	6,462,754
Other.....do....	(1)	2,012,417	(1)	2,622,098	7,571,827	2,049,369
Total gums....do....	(1)	214,629,138	(1)	228,228,874	498,884,123	182,979,548
Ivory, vegetable, pounds..	51,699,719	1,427,780	42,873,018	1,255,719	30,785,593	1,013,146
Naval stores—						
Turpentine, spirits of, gallons.....	18,661	8,691	1,670	636	.....	.....
Tanning materials—						
Mangrove bark, long tons.....	10,565	299,897	3,529	72,956	2,817	125,603
Quebracho, extract of, pounds.....	59,808,734	5,198,904	101,523,282	4,917,212	136,995,903	5,856,803
Quebracho wood, long tons.....	73,367	1,274,660	45,440	718,567	1,505	15,050
Sumac, ground, pounds.....	11,637,023	365,173	14,046,662	467,663	9,311,055	307,843
Other.....	.....	792,064	.....	496,070	.....	547,124
Total tanning ma- terials.....	.....	7,930,698	.....	6,672,468	.....	6,852,423
Wood, not elsewhere specified—						
Brier root or brierwood and ivy or laurel root	.....	589,607	.....	555,201	.....	876,433
Chair cane or reed.....	.....	235,488	.....	203,037	.....	223,894
Cabinet woods, un- sawed—						
Cedar.....M feet..	12,582	693,675	12,354	840,323	8,456	643,203
Mahogany.....do....	42,780	2,888,615	51,681	3,731,389	48,261	4,300,116
Other.....do....	(1)	684,562	(1)	473,751	10,910	882,957
Total cabinet woods...M feet..	(1)	4,266,852	(1)	5,045,463	67,627	5,826,276
Logs and round tim- ber.....M feet..	134,841	1,270,348	65,394	815,247	39,888	765,368

1 Not stated.

TABLE 268.—Agricultural imports of the United States during the 3 years ending June 30, 1919—Continued.

Article imported.	Year ending June 30—					
	1917		1918		1919 (preliminary).	
	Quantity.	Value.	Quantity.	Value.	Quantity.	Value.
VEGETABLE MATTER—con.						
Forest products—Contd.						
Wood, not elsewhere specified—Continued.						
Lumber—						
Boards, deals, planks, and other sawed lumber . . . M feet..	1, 175, 319	\$24, 514, 751	1, 282, 701	\$32, 694, 374	980, 010	\$29, 135, 881
Laths . . . . . M..	766, 286	2, 280, 656	410, 626	1, 376, 273	401, 846	1, 357, 244
Shingles . . . . . M..	1, 924, 139	4, 568, 340	1, 878, 465	5, 453, 951	1, 757, 170	5, 863, 927
Other . . . . .		730, 158		881, 122		1, 111, 143
Total lumber . . . . .		32, 093, 905		40, 405, 720		37, 468, 195
Pulp wood—						
Peeled . . . . . cords..	639, 816	4, 285, 282	822, 816	7, 821, 335	956, 884	9, 285, 900
Rossed . . . . . do..	162, 818	1, 295, 957	138, 690	1, 621, 306	131, 606	1, 626, 102
Rough . . . . . do..	214, 180	1, 307, 884	210, 527	1, 645, 781	301, 844	2, 796, 445
Rattan and reeds . . . . .		1, 171, 052		1, 781, 239		867, 340
Timber, ship and other . . . . .		( <sup>1</sup> )		( <sup>1</sup> )		459, 922
All other . . . . .		689, 234		1, 281, 626		550, 631
Total wood, n. e. s. . . . .		47, 205, 609		61, 175, 955		60, 746, 506
Wood pulp—						
Chemical—						
Bleached . . long tons..	47, 767	4, 723, 371	18, 044	2, 135, 384	21, 228	2, 269, 266
Unbleached . . do..	381, 601	30, 720, 219	296, 509	23, 314, 875	289, 432	22, 829, 804
Mechanical . . do..	270, 107	7, 018, 404	189, 599	6, 138, 831	165, 031	4, 482, 033
Total wood pulp, long tons . . . . .	699, 475	42, 461, 994	504, 152	31, 589, 090	475, 691	29, 581, 103
Total forest products . . . . .		322, 699, 430		335, 033, 459		284, 684, 442
Fruits:						
Fresh or dried—						
Bananas . . . . . bunches..	34, 661, 179	12, 724, 198	34, 549, 913	15, 147, 643	35, 382, 306	15, 772, 277
Currants . . . . . pounds..	10, 476, 534	1, 056, 525	5, 168, 070	561, 904	841, 721	114, 624
Dates . . . . . do..	25, 485, 361	622, 934	5, 572, 908	249, 621	20, 192, 160	891, 068
Figs . . . . . do..	16, 479, 733	704, 164	10, 473, 239	715, 423	9, 239, 070	960, 596
Grapefruit . . . . .		( <sup>1</sup> )		( <sup>1</sup> )		447, 257
Grapes . . . . . cubic feet..	1, 402, 446	1, 656, 609	556, 558	648, 093	695, 883	1, 037, 587
Lemons . . . . . pounds..		2, 163, 583		2, 179, 211		1, 438, 884
Olives . . . . . gallons..	5, 641, 759	2, 338, 615	2, 385, 059	1, 062, 487	3, 501, 371	1, 786, 609
Oranges . . . . . pounds..		160, 710		62, 906		85, 859
Pineapples . . . . .		935, 906		801, 298		1, 011, 099
Raisins . . . . . pounds..	1, 850, 219	234, 560	843, 533	153, 319	119, 969	34, 827
Other . . . . .		1, 936, 561		2, 114, 444		1, 657, 070
Total fresh or dried . . . . .		24, 534, 365		23, 696, 349		25, 237, 757
Prepared or preserved . . . . .		781, 586		712, 461		578, 946
Total fruits . . . . .		25, 315, 951		24, 408, 810		25, 816, 703
Grain and grain products:						
Grain—						
Corn . . . . . bushels..	2, 267, 299	1, 488, 529	3, 196, 420	3, 483, 101	3, 311, 211	3, 271, 623
Oats . . . . . do..	761, 644	473, 476	2, 591, 077	1, 963, 447	551, 355	441, 269
Wheat . . . . . do..	24, 138, 817	41, 900, 498	28, 177, 281	56, 873, 063	11, 121, 461	19, 132, 902
Total grain . . . . . do..	27, 167, 760	43, 862, 503	33, 964, 778	62, 319, 611	14, 984, 027	22, 845, 794
Grain products—						
Bread and biscuit, pounds . . . . .	( <sup>1</sup> )	148, 401	( <sup>1</sup> )	100, 141	558, 779	89, 439
Macaroni, vermicelli, etc. . . . . pounds..	3, 472, 503	262, 909	669, 524	54, 713	591, 804	58, 899
Meal and flour—						
Wheat flour, barrels..	174, 704	1, 458, 279	675, 096	6, 372, 333	38, 040	385, 816
Other . . . . .		3, 664, 279		7, 445, 828		3, 864, 345
Total grain prod-ucts . . . . .		5, 533, 868		13, 973, 015		4, 398, 499
Total grain and grain products . . . . .		49, 396, 371		76, 292, 626		27, 244, 293

<sup>1</sup> Not stated.



TABLE 268.—Agricultural imports of the United States during the 3 years ending June 30, 1919—Continued.

Article imported.	Year ending June 30—					
	1917		1918		1919 (preliminary).	
	Quantity.	Value.	Quantity.	Value.	Quantity.	Value.
<b>VEGETABLE MATTER—con.</b>						
Hay.....long tons..	58,147	\$628,021	410,738	\$4,618,764	277,448	\$3,677,025
Hops.....pounds..	236,849	59,291	121,288	72,450	6	14
Indigo.....do....	2,812,739	4,108,910	3,126,497	3,895,114	1,590,176	1,551,467
Licorice root.....do....	59,400,224	2,190,822	26,982,932	1,853,927	42,684,025	3,445,022
<b>Liquors, alcoholic:</b>						
<b>Distilled spirits—</b>						
Brandy.....proof galls..	420,567	1,502,845	234,912	1,149,969	326	1,008
Cordials, liqueurs, etc., proof galls.....	357,311	902,696	76,120	215,803	13,018	48,580
Gin.....proof galls..	263,520	439,244	112,649	256,158	292	355
Whisky.....do....	1,676,151	4,404,486	796,267	2,487,831	315	892
Other.....do....	397,934	543,620	157,148	221,722	573	482
Total distilled spirits, proof galls.....	3,115,483	7,792,891	1,377,096	4,331,483	14,524	51,317
<b>Malt liquors—</b>						
Bottled.....gallons..	632,064	717,653	298,390	416,576	24,670	27,387
Unbottled.....do....	1,608,113	682,843	463,676	292,331	2,472	1,524
Total malt liquors, gallons.....	2,240,177	1,400,496	762,066	708,907	27,142	28,911
<b>Wines—</b>						
Champagne and other sparkling...doz. qts..	195,714	3,442,645	124,230	2,167,627	31,624	647,668
<b>Still wines—</b>						
Bottled.....doz. qts..	534,402	2,485,014	415,491	2,237,116	64,154	413,959
Unbottled.....gallons..	3,167,400	2,558,086	2,357,862	2,209,960	910,692	977,567
Total still wines.....		5,043,100		4,447,076		1,391,526
Total wines.....		8,485,745		6,614,703		2,039,194
Total alcoholic liq- uors.....		17,679,132		11,655,093		2,119,422
Malt, barley. (See Grain and grain products.)						
Malt liquors. (See Liq- uors, alcoholic.)						
<b>Nursery stock:</b>						
<b>Plants, trees, shrubs, and vines—</b>						
Bulbs, bulbous roots or corms, cultivated for their flowers or foli- age.....M..	293,318	2,886,189	233,219	2,804,057	95,169	1,421,273
Stocks, cuttings, and seedlings.....M..	( <sup>1</sup> )	( <sup>1</sup> )	( <sup>1</sup> )	( <sup>1</sup> )	16,713	699,730
Other.....		1,078,324		524,643		242,550
Total nursery stock..		3,964,513		3,328,700		2,363,553
<b>Nuts:</b>						
<b>Almonds—</b>						
Shelled.....pounds..	18,413,225	4,621,100	19,561,155	4,956,419	23,594,915	7,467,545
Unshelled.....do....	5,010,833	548,826	4,278,990	497,989	6,733,512	1,040,077
Coconuts, unshelled.....		2,587,535		2,788,635	73,609,712	2,743,796
<b>Coconut meat, broken, or copra—</b>						
Not shredded, desic- cated, or prepared, pounds.....	247,057,739	12,517,982	486,996,112	26,945,569	302,560,488	19,853,182
Shredded, desiccated, or prepared.pounds..	9,743,024	727,424	20,579,973	2,396,104	13,784,032	1,726,982
Cream and Brazil, pounds.....	14,627,742	712,433	30,439,095	1,470,089	31,418,342	1,860,673
<b>Filberts—</b>						
Shelled.....pounds..	2,058,732	487,021	3,279,807	615,226	3,201,297	783,156
Unshelled.....do....	11,181,301	1,354,257	17,366,979	1,869,430	6,442,643	891,683

<sup>1</sup> Not stated.

TABLE 268.—Agricultural imports of the United States during the 3 years ending June 30, 1919.

Article imported.	Year ending June 30—					
	1917		1918		1919 (preliminary).	
	Quantity.	Value.	Quantity.	Value.	Quantity.	Value.
VEGETABLE MATTER—CON.						
Nuts—Continued.						
Marrons, crude.. pounds..	(1)	(1)	(1)	(1)	746,956	\$38,837
Palm and palm-nut kernels..... pounds..	(1)	(1)	(1)	(1)	19,590,551	339,708
Peanuts—						
Shelled..... do.....	27,180,748	\$1,193,364	73,362,215	\$4,617,560	19,462,080	1,108,734
Unshelled..... do.....	7,806,012	339,811	3,150,747	153,054	1,444,221	99,490
Walnuts—						
Shelled..... do.....	13,058,518	3,713,340	11,155,660	4,251,567	7,695,651	3,534,403
Unshelled..... do.....	25,666,844	2,497,454	12,133,510	1,438,944	3,240,979	468,844
Other.....		1,575,139		850,202		558,545
Total nuts.....		32,875,686		52,850,788		42,515,661
Oil cake..... pounds..	52,671,866	554,871	35,149,142	574,032	71,366,840	2,579,526
Oils, vegetable:						
Fixed or expressed—						
Cocoa butter or butterine..... pounds..	166,172	55,564	405	74	566,923	60,087
Coconut oil..... pounds..	79,223,398	9,132,095	259,194,853	30,919,783	324,270,366	43,496,543
Cottonseed..... do.....	13,703,126	1,039,080	14,291,312	1,629,111	20,410,022	2,625,255
Flaxseed or linseed, gallons.....	110,808	76,530	50,827	32,203	989,812	1,239,597
Nut oil, or oil of nuts, n. e. s.—						
Chinese nut.gallons..	6,864,110	4,046,132	4,815,740	4,038,072	6,216,645	7,245,915
Peanut..... do.....	3,026,188	2,036,592	8,288,756	7,311,824	11,392,724	11,495,849
Olive for mechanical purposes..... gallons..	651,018	615,350	114,324	94,629	114,642	177,757
Olive, edible..... do.....	7,533,149	10,502,671	2,537,512	3,873,211	4,283,136	8,010,626
Palm oil..... pounds..	36,074,059	3,316,417	27,405,231	2,527,301	19,280,762	1,651,230
Palm kernel..... do.....	1,857,038	197,237	18,618	2,583	1,945,345	144,826
Rapeseed..... gallons..	1,084,905	645,090	3,056,438	2,702,920	2,091,052	2,264,594
Soya bean..... pounds..	162,690,235	11,410,606	333,824,646	32,827,460	236,805,005	28,032,683
Other.....		495,191		2,027,142		1,849,473
Total fixed or expressed.....		43,568,555		87,986,313		108,294,435
Volatile or essential—						
Birch and cajeput, pounds.....	(1)	33,302	(1)	25,981	18,853	11,239
Lemon..... do.....	449,735	373,933	628,057	427,318	490,241	470,501
Other.....		3,038,177		3,917,710		3,855,490
Total volatile or essential.....		3,445,412		4,371,009		4,337,230
Total vegetable oils.....		47,013,967		92,357,322		112,631,665
Opium, crude..... pounds..	86,812	843,418	157,834	2,443,228	345,514	5,166,058
Rice, rice meal, etc.:						
Rice—						
Cleaned..... pounds..	97,453,036	2,735,702	345,676,204	12,224,984	280,205,782	13,527,101
Uncleaned, including paddy..... pounds..	80,865,798	2,290,173	62,317,754	2,558,034	49,688,672	3,141,665
Rice flour, rice meal, and broken rice, pounds.....	37,730,024	747,922	48,064,650	1,528,687	33,831,809	1,217,223
Total rice, etc., pounds.....	216,048,858	5,773,797	456,058,608	16,311,705	363,726,263	17,885,989
Sago, tapioca, etc. pounds..	(1)	3,712,956	(1)	5,530,889	56,507,281	2,730,278

1 Not stated.

TABLE 268.—Agricultural imports of the United States during the 3 years ending June 30, 1919—Continued.

Article imported.	Year ending June 30—					
	1917		1918		1919 (pre'iminary).	
	Quantity.	Value.	Quantity.	Value.	Quantity.	Value.
<b>VEGETABLE MATTER—CON.</b>						
<b>Seeds:</b>						
Caster beans or seeds, bushels.....	766,857	\$1,184,985	1,044,014	\$2,273,882	628,312	\$2,188,939
<b>Clover—</b>						
Red.....pounds..	5,971,267	936,092	905,709	162,418	1,157,950	354,081
Other.....do....	12,200,892	1,569,782	7,072,386	1,322,027	10,153,961	2,472,298
Flaxseed or linseed, bushels.....	12,393,988	25,149,669	13,366,529	34,217,074	8,426,886	22,620,762
Grass seed, n. e. s. pounds..	9,187,613	849,630	5,974,944	504,240	5,040,359	608,404
Mustard.....do....	(1)	(1)	(1)	(1)	11,272,769	842,033
Sugar beet.....do....	14,469,774	1,684,867	15,635,542	4,541,226	986,676	247,798
Other.....do....		4,504,640		7,820,756		5,878,349
<b>Total seeds.....</b>		<b>35,879,665</b>		<b>50,841,623</b>		<b>35,212,664</b>
<b>Spices:</b>						
<b>Unground—</b>						
Capsicum.....pounds..	(1)	(1)	(1)	(1)	2,089,509	244,055
Cassia, or cassia vera, pounds.....	8,744,044	740,846	8,220,023	856,035	8,944,316	728,792
Cloves.....pounds..	(1)	(1)	(1)	(1)	6,479,738	1,719,984
Ginger root, not preserved.....pounds..	2,590,279	243,962	6,544,069	601,392	1,410,236	105,034
Nutmegs.....do....	(1)	(1)	(1)	(1)	4,501,656	812,659
Pepper, black or white, pounds.....	23,961,966	3,636,049	38,545,653	6,043,483	39,734,797	6,441,713
Other.....pounds..	13,785	879	1,564	99		
<b>Total unground, pounds.....</b>	<b>35,310,074</b>	<b>4,621,736</b>	<b>53,311,309</b>	<b>7,501,009</b>	<b>63,160,252</b>	<b>10,052,237</b>
<b>Ground—</b>						
Capsicum.....pounds..	23,220,288	3,123,286	24,751,425	4,018,304	2,276,418	682,111
Mustard.....do....					1,184,380	584,382
Other.....do....					5,736,515	871,830
<b>Total ground...do....</b>	<b>23,220,288</b>	<b>3,123,286</b>	<b>24,751,425</b>	<b>4,018,304</b>	<b>9,197,313</b>	<b>2,138,323</b>
<b>Total spices....do....</b>	<b>58,530,362</b>	<b>7,745,022</b>	<b>78,062,734</b>	<b>11,519,313</b>	<b>72,357,565</b>	<b>12,190,560</b>
<b>Spirits, distilled. (See Liquors, alcoholic.)</b>						
Starch.....pounds..	20,647,893	973,530	23,852,145	1,673,477	12,011,177	1,042,469
<b>Sugar and molasses:</b>						
Molasses.....gallons..	110,237,888	10,946,571	130,730,861	9,177,833	130,074,717	7,471,060
<b>Sugar—</b>						
<b>Raw—</b>						
Beet.....pounds..	28,847	1,443	750	73	1,180	108
Cane.....do....	5,329,587,360	230,574,221	4,898,277,025	236,105,886	5,831,982,457	308,346,986
Maple sugar and sirup.....pounds..	3,129,647	370,030	5,049,474	909,412	4,064,085	1,056,220
<b>Total raw...do....</b>	<b>5,332,745,854</b>	<b>230,945,694</b>	<b>4,903,327,249</b>	<b>237,015,371</b>	<b>5,836,047,722</b>	<b>309,403,314</b>
<b>Total sugar and molasses.....</b>		<b>241,892,265</b>		<b>246,193,204</b>		<b>316,874,374</b>
Tea.....pounds..	103,364,410	19,265,264	151,314,932	30,889,030	108,172,102	24,390,722
Tea, waste, etc., for manufacturing.....pounds..	7,975,343	494,280	10,869,765	780,495		
<b>Tobacco:</b>						
<b>Leaf—</b>						
Wrapper.....pounds..	3,957,489	5,304,687	4,815,207	5,507,647	12,324,482	13,306,602
Filler and other leaf, pounds.....	45,147,630	20,617,968	82,175,334	41,478,218	71,626,621	53,023,087
<b>Total tobacco, pounds.....</b>	<b>49,105,119</b>	<b>25,922,655</b>	<b>86,990,541</b>	<b>46,985,865</b>	<b>83,951,103</b>	<b>66,329,689</b>

<sup>1</sup> Not stated.

TABLE 268.—Agricultural imports of the United States during the 3 years ending June 30, 1919—Continued.

Article imported.	Year ending June 30—					
	1917		1918		1919 (preliminary).	
	Quantity.	Value.	Quantity.	Value.	Quantity.	Value.
VEGETABLE MATTER—CON.						
Vanilla beans.....pounds..	799,893	\$1,662,578	914,668	\$1,475,676	942,369	\$1,677,316
Vegetables:						
Fresh and dried—						
Beans.....bushels..	3,747,993	12,137,048	4,145,625	17,274,504	4,015,860	15,957,655
Garlic.....pounds..	( <sup>1</sup> )	( <sup>1</sup> )	( <sup>1</sup> )	( <sup>1</sup> )	4,296,317	377,220
Onions.....bushels..	1,757,948	1,820,396	1,313,402	1,032,834	152,323	260,596
Peas, dried.....do....	1,163,021	3,035,052	2,068,054	5,885,072	2,253,392	9,041,081
Potatoes—						
Irish.....do.....	3,079,025	4,705,812	1,180,480	1,456,136	3,534,076	3,635,555
Sweet and desiccated prepared.....		( <sup>1</sup> )		( <sup>1</sup> )		479,754
Other.....		2,668,321		2,150,537		1,927,167
Total fresh and dried.....		24,366,629		27,799,083		31,679,028
Prepared or preserved—						
Mushrooms...pounds..	4,384,788	1,463,164	2,050,803	798,697	834,917	414,914
Pickles and sauces.....		1,179,959		309,124		619,960
Other.....		2,141,137		1,268,865		973,403
Total prepared or pre- served.....		4,784,260		2,376,686		2,008,277
Total vegetables.....		29,150,889		30,175,769		33,687,305
Vinegar.....gallons..	203,504	88,037	68,772	34,228	63,170	34,834
Wax, vegetable...pounds..	7,216,103	1,739,199	8,707,396	2,693,258	8,321,515	3,011,559
Wines. (See Liquor, alco- holic.)						
Total vegetable mat- ter, including forest products.....		1,167,208,230		1,349,901,163		1,354,792,164
Total vegetable mat- ter, excluding forest products.....		8,444,508,800		1,014,867,704		1,070,107,722
Total agricultural im- ports, including for- est products.....		1,727,671,538		1,953,907,437		2,067,120,230
Total agricultural im- ports, excluding for- est products.....		1,404,972,108		1,618,873,978		1,782,435,788

<sup>1</sup> Not stated.

TABLE 269.—Agricultural exports (domestic) of the United States during the 3 years ending June 30, 1919.

Article exported.	Year ending June 30—					
	1917		1918		1919 (preliminary).	
	Quantity.	Value.	Quantity.	Value.	Quantity.	Value.
<b>ANIMAL MATTER.</b>						
Animals, alive:						
Cattle.....number..	13,387	\$949,503	18,213	\$1,247,800	42,345	\$2,092,816
Horses.....do.....	278,674	59,525,329	84,765	14,923,663	27,975	5,206,251
Mules.....do.....	136,689	27,800,854	28,879	4,885,406	12,452	2,333,929
Sheep.....do.....	58,811	367,935	7,959	97,028	16,117	187,347
Swine.....do.....	21,926	347,852	9,280	256,629	17,390	520,910
Other (including fowls).....		391,380		323,068		377,598
Total animals.....		89,382,853		21,733,594		10,718,851
Beeswax.....pounds..	383,667	131,691	189,871	68,117	134,508	67,237
Dairy products:						
Butter.....do.....	26,835,092	8,749,170	17,735,966	6,852,727	33,739,960	15,843,522
Cheese.....do.....	66,050,013	15,240,033	44,303,076	10,785,153	18,794,853	5,733,029
Milk—						
Condensed.....do.....	259,141,231	25,136,641	528,759,232	68,045,944	728,740,509	99,970,769
Other, including cream.....		253,629		227,042		613,623
Total dairy products, pounds.....		49,379,473		85,910,866		122,160,943
Eggs.....dozen..	24,926,424	7,568,911	18,969,167	7,167,134	28,384,783	12,449,345
Egg yolks.....		72,491		525,880		341,304
Feathers.....		368,862		302,236		521,747
Fibers, animal:						
Silk waste.....pounds..	21,782	13,418				
Wool.....do.....	2,148,350	1,230,296	993,143	916,506	545,717	550,772
Total animal fibers.....	2,170,132	1,243,714	993,143	916,506	545,717	550,772
Glue.....pounds..	4,064,231	513,775	4,901,764	837,679	7,283,683	1,432,589
Honey.....do.....	( <sup>1</sup> )	736,139	16,090,672	2,509,570	10,368,342	2,422,454
Packing-house products:						
Beef—						
Canned.....pounds..	67,536,125	16,946,030	97,343,283	30,034,707	108,489,472	44,320,197
Cured or pickled.....do.....	58,053,667	6,728,359	54,467,910	7,702,524	45,067,861	9,087,262
Fresh.....do.....	197,177,101	26,277,271	370,032,900	67,383,426	332,205,176	79,227,540
Oils—oleo oil.....do.....	67,110,111	11,065,019	56,603,388	12,152,787	59,092,322	15,720,944
Oleomargarine.....do.....	5,651,267	901,659	6,309,896	1,631,267	18,570,200	5,179,339
Stearin.....do.....	12,936,357	1,798,317	10,360,030	2,181,317	11,537,284	2,309,979
Tallow.....do.....	15,209,369	1,800,909	5,014,964	931,941	16,210,997	2,327,705
Total beef.....do.....	423,673,997	65,517,564	600,132,371	122,017,969	591,173,312	158,172,966
Bones and manufactures of.....		103,477				
Grease, grease scraps, and all soap stock—						
Lubricating.....		2,816,958		2,986,815		4,878,115
Soap stock.....		3,405,227		2,612,488		2,811,338
Hair.....		1,451,354		1,080,624		1,223,628
Hides and skins, other than furs—						
Calfskins.....pounds..	1,374,038	549,459	3,458,001	1,462,456	2,778,393	1,597,141
Cattle hides.....do.....	7,365,461	2,041,357	7,023,761	1,953,700	10,205,357	3,238,151
Horse.....do.....	179,704	32,900	43,113	11,832	69,597	14,140
Other.....do.....	1,052,046	347,115	1,619,942	661,505	1,737,326	729,671
Total.....	9,971,249	2,970,831	12,144,817	4,089,493	14,790,673	5,579,108
Hoofs, horns, and horn tips, strips, and waste.....		39,804		338,642		330,677
Lard compounds, pounds.....	56,359,493	8,269,844	31,278,382	6,633,640	131,750,503	32,036,692
Meat, canned, n. e. s.....		4,320,652		5,700,738		15,003,168
Mutton.....pounds..	3,195,576	481,526	2,098,423	453,232	2,173,994	511,065
Oils, animal, n. e. s., gallons.....	416,213	378,294	329,576	409,466	1,422,344	2,023,190

<sup>1</sup> Not stated.

TABLE 269.—Agricultural exports (domestic) of the United States during the 3 years ending June 30, 1919—Continued.

Article exported.	Year ending June 30—					
	1917		1918		1919 (preliminary).	
	Quantity.	Value.	Quantity.	Value.	Quantity.	Value.
<b>ANIMAL MATTER—contd.</b>						
<b>Packing-house products—Continued.</b>						
<b>Pork—</b>						
Canned.....pounds..	5,896,126	\$1,645,605	5,194,468	\$1,731,835	5,273,508	\$1,997,386
<b>Cured—</b>						
Bacon.....pounds..	667,151,972	117,221,668	815,294,424	221,473,957	1,239,540,973	378,729,046
Hams and shoulders, pounds.....	266,656,581	49,574,041	419,571,869	108,106,862	667,848,019	204,667,696
Salted or pickled, pounds.....	46,992,721	6,941,306	33,221,502	7,545,011	31,504,497	7,444,532
Total cured, pounds.....	980,801,274	173,737,015	1,268,087,795	337,125,830	1,938,893,489	590,841,274
Fresh.....pounds..	50,435,615	8,875,889	21,390,288	5,225,982	19,644,388	6,065,267
Lard.....do.....	444,769,540	77,008,913	392,506,355	98,216,856	725,577,868	210,417,859
Lard, neutral.....do.....	17,576,240	3,168,089	4,258,529	1,074,603	17,395,888	5,392,710
Oils—lard oil {pounds..	{ 2,469,330	{ 321,721	{ 686,888	{ 126,672	{ 618,525	{ 124,887
{gallons..						
Total pork..pounds..	1,501,948,125	264,757,232	1,692,124,323	443,501,778	2,707,403,666	814,839,383
<b>Sausage and sausage meats—</b>						
Canned.....pounds..	6,294,950	1,316,320	5,787,108	1,487,874	8,503,580	2,782,551
Other.....do.....	9,134,471	2,441,510	9,239,341	3,232,681	9,721,925	3,882,751
Sausage casings..do....	6,118,060	1,741,959	6,173,578	3,014,537	13,524,093	4,938,202
All other.....		3,960,572		6,768,007		9,848,394
Total packing-house products.....		363,973,124		604,327,984		1,058,861,223
Poultry and game.....		1,327,348		1,241,144		3,799,348
Wool. (See Fibers, animal.)						
Total animal matter.....		514,698,381		725,540,710		1,213,325,813
<b>VEGETABLE MATTER.</b>						
<b>Breadstuffs. (See Grain and grain products.)</b>						
Broom corn.....long tons..	3,218	684,682	3,972	1,293,042	3,737	1,030,397
Cocoa, ground or prepared, and chocolate.....		3,451,519		5,898,431		10,835,409
<b>Coffee:</b>						
Green or raw...pounds..	42,916,479	6,405,837	40,718,088	5,899,661	37,224,166	7,252,294
Roasted or prepared, pounds.....	2,167,508	439,026	1,986,712	386,519	5,566,809	1,199,298
Total coffee.pounds..	45,083,987	6,844,863	42,704,800	6,286,180	42,790,975	8,451,592
<b>Cotton:</b>						
Sea Island.....{bales... 2,311	{ 458,728	{ 2,236	{ 633,867	{ 4,746	{ 1,217,246	
{pounds.. 943,864						{ 892,369
Upland.....{bales... 5,470,150	{ 518,505,147	{ 4,336,530	{ 653,731,647	{ 5,204,508	{ 856,524,391	
{pounds.. 2,850,162,770						{ 2,226,556,494
Linters.....{bales... 474,704	{ 24,110,815	{ 190,078	{ 10,659,141	{ 86,457	{ 5,419,772	
{pounds.. 236,974,152						{ 93,062,802
Total cotton...do....	3,088,080,786	543,074,690	2,320,511,665	665,024,655	2,733,683,125	863,161,409
<b>Flavoring extracts and fruit juices.....</b>						
Flowers, cut.....		581,550		1,018,102		949,726
		105,615		156,559		177,467
<b>Forest products:</b>						
<b>Bark, and extract of, for tanning—</b>						
Bark.....long tons..	1,851	49,807	194	5,857	726	40,151
Bark, extracts of.....		3,908,573		3,804,563		3,254,947
Total bark, etc.....		3,958,380		3,810,420		3,295,098

1One gallon equals 7.5 pounds.

TABLE 269.—Agricultural exports (domestic) of the United States during the 3 years ending June 30, 1919—Continued.

Article exported.	Year ending June 30—					
	1917		1918		1919 (preliminary).	
	Quantity.	Value.	Quantity.	Value.	Quantity.	Value.
VEGETABLE MATTER—CON.						
Forest products—Contd.						
Logwood extract.....		(1)		\$2,339,480		\$1,556,023
Charcoal.....		\$155,470				
Moss.....		82,881		99,793		56,916
Naval stores—						
Rosin.....barrels..	1,638,590	10,705,972	1,070,929	7,878,718	881,777	11,323,381
Tar, turpentine, and pitch.....barrels..	103,387	561,566	82,030	598,211	48,030	385,142
Turpentine, spirits of, gallons.....	8,841,875	4,313,670	5,095,124	2,695,935	8,063,578	6,068,974
Total naval stores.....		15,581,208		11,172,864		17,777,497
Wood—						
Logs—						
Hickory.....M feet..	251	13,273	(2)	(2)	(2)	(2)
Oak.....do.....	842	27,817				
Walnut.....do.....	1,604	167,350				
Other.....do.....	48,537	784,687				
Total.....do.....	51,234	993,127	(2)	(2)	(2)	(2)
Logs and round timber—						
Fir.....M feet..	(3)	(3)	8,281	124,550	4,403	94,536
Pine, yellow.....do.....			6,895	197,816	4,620	129,126
Other logs—			1,240	62,600	3,452	154,598
Hardwood.....do.....						
Softwood.....do.....	(3)	(3)	33,980	703,809	24,385	631,945
Total.....do.....	(3)	(3)	33,980	703,809	24,385	631,945
Lumber—						
Boards, deals, and planks—						
Cypress.....M feet..	8,715	286,882	22,097	1,262,220	14,520	877,321
Fir.....do.....	289,980	3,763,049	274,263	6,677,124	272,498	9,215,553
Gum.....do.....	19,389	545,762	31,027	1,306,829	43,303	2,174,438
Oak.....do.....	54,030	2,332,739	67,216	3,374,823	100,849	6,212,529
Pine—						
White.....do.....	24,523	957,902	22,625	1,071,112	23,043	1,276,896
Yellow—						
Pitch pine, M feet.....	402,704	8,332,957	346,117	9,874,981	300,004	10,572,254
Short-leaf pine, M feet.....	3,042	66,028	5,657	183,367	19,581	703,448
Other pine, M feet.....	64,915	1,539,664	97,132	2,813,987	90,262	3,042,160
Poplar.....M feet..	7,369	324,666	19,199	1,179,859	28,103	1,977,372
Redwood.....do.....	23,289	732,672	20,964	733,176	42,623	1,499,836
Spruce.....do.....	57,497	3,150,622	72,743	6,758,438	45,648	5,505,682
Other.....do.....	86,392	5,054,797	88,669	9,072,061	97,539	8,990,844
Total.....do.....	1,041,845	27,087,740	1,067,709	44,307,977	1,077,973	52,046,333
Railroad ties, number.....						
Shingles.....M..	3,934,107	2,369,834	3,435,297	2,801,256	3,301,299	2,782,831
Shooks—						
Box.....		2,029,683		2,511,223		2,680,811
Cooperage, number.....	(1)	(1)	1,365,027	3,278,180	2,500,281	6,398,719
Other.....do.....	1,079,510	2,356,492	393,640	792,999	527,420	534,576
Total shooks.....		4,386,175		6,582,402		9,614,106
Staves and heading—						
Heading.....		287,174		440,525		589,314
Staves.....number..	61,469,225	3,921,882	63,207,351	3,724,895	62,538,922	7,856,119
Total staves and heading.....		4,209,056		4,165,420		8,445,433
Other.....		2,923,712		1,966,737		3,536,543
Total lumber.....		41,070,973		59,919,934		76,510,836

1 Not stated.

2 Included in Logs and round timber.

3 Included in Logs.

TABLE 269.—Agricultural exports (domestic) of the United States during the 3 years ending June 30, 1919—Continued.

Article exported.	Year ending June 30—					
	1917		1918		1919 (preliminary).	
	Quantity.	Value.	Quantity.	Value.	Quantity.	Value.
VEGETABLE MATTER—CON.						
Forest products—Contd.						
Timber—						
Hewn—						
Hardwood, M feet..	7,293	\$211,384	1,965	\$98,440	1,828	\$101,632
Softwood, M feet...			5,461	163,893	3,193	79,151
Sawed—						
Pitch pine...do....	149,527	3,368,977	65,233	1,948,636	62,928	2,533,247
Other.....do.....	27,545	628,762	33,558	1,044,576	23,842	797,547
Total timber, M feet.....	184,365	4,209,123	106,217	3,255,545	91,791	3,511,577
All other, including firewood.....		203,596		277,593		220,007
Total wood.....		46,476,819		64,156,881		80,874,365
Wood alcohol...gallons..	823,694	645,439	2,538,001	2,070,026	1,339,204	1,299,340
Wood pulp....long tons..	26,019	2,018,639	34,786	3,531,304	26,397	2,193,133
Total forest products.....		68,918,836		87,180,768		107,052,372
Fruits:						
Fresh or dried—						
Apples, dried.pounds..	10,357,791	797,487	2,602,590	330,170	19,313,882	2,954,090
Apples, fresh..barrels..	1,739,997	7,979,236	635,409	2,813,091	1,576,748	12,084,302
Apricots, dried pounds.....	9,841,119	1,298,176	5,229,618	767,780	20,975,214	3,775,218
Berries.....		822,977		838,813		1,029,426
Lemons.....boxes..	174,938	626,270	138,063	728,791	304,351	1,404,446
Oranges.....do.....	1,850,372	4,397,067	1,240,477	4,608,048	1,402,180	6,347,264
Peaches, dried pounds.....	8,187,588	605,620	5,862,605	627,841	4,834,738	662,080
Pears, fresh.....		1,356,259		978,298		1,105,181
Prunes.....pounds..	59,645,141	4,934,329	32,926,546	3,060,691	59,072,436	7,946,241
Raisins.....do.....	51,992,514	4,409,639	54,987,793	4,981,270	84,150,060	8,066,001
Other.....		3,619,266		4,192,914		5,085,233
Total fresh or dried.....		30,846,326		23,927,707		50,459,482
Preserved—						
Canned.....						
Other.....		6,138,692		7,024,466		14,595,703
Other.....		413,291		1,255,191		4,089,002
Total preserved.....		6,551,983		8,279,657		18,684,705
Total fruits.....		37,398,309		32,207,364		69,144,187
Ginseng.....pounds..	198,480	1,386,203	259,892	1,717,548	281,943	2,057,232
Glucose and grape sugar:						
Glucose.....pounds..	170,025,606	5,960,586	80,970,744	4,949,159	118,835,491	6,588,697
Grape sugar.....do....	44,947,709	1,398,145	16,887,557	1,045,512	17,394,882	875,355
Grain and grain products:						
Grain—						
Barley.....bushels..	16,381,077	19,027,082	26,285,378	41,650,886	20,457,781	27,687,047
Buckwheat.....do....	260,102	350,606	5,567	10,347	119,516	183,624
Corn.....do.....	64,720,842	72,497,204	40,997,827	75,305,692	16,687,538	26,705,819
Oats.....do.....	88,944,401	55,034,981	105,837,309	86,125,093	96,360,974	79,492,663
Rye.....do.....	13,260,015	21,599,631	11,990,123	23,902,848	27,540,188	53,653,629
Wheat.....do.....	149,831,427	298,179,705	34,118,853	80,802,542	178,582,673	424,543,010
Total grain....do....	333,397,864	466,689,209	219,235,057	307,797,408	339,748,670	612,265,792
Grain products—						
Bran and middlings, long tons.....						
	7,428	279,650	6,833	286,545	6,213	311,701
Breadstuff preparations—						
Bread and biscuit, pounds.....						
Other.....	11,766,580	1,115,405	14,917,301	1,973,388	8,602,953	1,549,432
Other.....		7,721,856		10,454,399		5,220,215
Total breadstuff preparations.....		8,837,261		12,427,787		6,769,647



TABLE 269.—Agricultural exports (domestic) of the United States during the 3 years ending June 30, 1919—Continued.

Article exported.	Year ending June 30—					
	1917		1918		1919 (preliminary).	
	Quantity.	Value.	Quantity.	Value.	Quantity.	Value.
VEGETABLE MATTER—CON.						
Grain and grain products—Continued.						
Grain products—Contd.						
Distillers' and brewers' grains and malt sprouts....long tons..	1,505	\$47,809	675	\$26,512	1,122	\$73,406
Malt.....bushels..	4,331,297	5,881,287	2,674,845	4,842,203	3,993,057	6,587,017
Meal and flour—						
Barley flour.barrels..	(1)	(1)	(1)	(1)	584,800	6,142,157
Corn meal.....do....	508,113	2,757,324	2,018,859	20,358,644	1,583,327	14,722,336
Oatmeal.....pounds..	110,903,344	4,491,154	346,559,435	17,566,846	227,587,679	13,217,974
Rye flour.....barrels..	73,914	525,347	866,049	9,298,496	1,488,077	15,218,913
Wheat flour....do....	11,942,778	93,198,474	21,879,951	244,861,140	24,190,092	268,062,907
Total meal and flour.....		100,972,299		292,085,126		317,364,287
Mill feed....long tons..	46,112	1,693,752	12,517	601,196	6,902	362,892
All other.....		1,133,583		5,840,769		2,396,407
Total grain products.....		118,845,641		316,110,138		333,865,357
Total grain and grain products.....		585,534,850		623,907,546		946,131,149
Hay.....long tons..	85,529	1,685,836	30,145	907,401	29,013	864,922
Hops.....pounds..	4,824,876	773,926	3,494,579	993,773	7,466,952	2,333,850
Lard compounds. (See Meat and meat products.)						
Liquors, alcoholic:						
Distilled spirits—						
Alcohol, including cologne spirits, proof gallons.....	51,941,634	16,027,867	8,351,142	4,619,878	11,884,383	6,145,115
Rum.....proof gallons..	1,394,796	1,529,113	461,571	473,016	92,609	131,817
Whisky—						
Bourbon.....do....	59,611	73,942	65,955	150,208	58,451	190,460
Rye.....do....	139,619	249,572	89,925	229,016	81,543	344,281
Total whisky....do....	199,230	323,514	155,880	379,224	139,994	534,741
Other.....do....	515,113	627,575	110,646	246,522	149,603	581,967
Total distilled spirits, proof gallons.....	54,050,773	18,508,069	9,079,239	5,718,640	12,266,589	7,393,640
Malt liquors—						
Bottled...dozen quarts..	966,146	1,379,921	1,012,698	1,680,745	1,235,765	2,541,771
Unbottled....gallons..	249,237	62,104	187,834	48,654	70,796	31,581
Total malt liquors.....		1,442,025		1,729,399		2,573,352
Wines.....gallons..	2,245,013	933,133	2,765,344	1,388,639	3,447,862	2,944,976
Total alcoholic liquors.....		20,883,227		8,836,678		12,911,968
Malt. (See Grain and grain products.)						
Malt liquors. (See Liquors, alcoholic.)						
Malt sprouts. (See Grain and grain products.)						
Nursery stock.....		220,341		260,763		333,356
Nuts:						
Peanuts.....pounds..	22,413,297	1,336,638	12,488,209	1,517,831	13,696,660	1,475,195
Other.....		403,870		745,483		673,431
Total nuts.....		1,740,508		2,263,314		2,148,626

1 Not stated.

TABLE 269.—Agricultural exports (domestic) of the United States during the 3 years ending June 30, 1919—Continued.

Article exported.	Year ending June 30—					
	1917		1918		1919 (preliminary).	
	Quantity.	Value.	Quantity.	Value.	Quantity.	Value.
<b>VEGETABLE MATTER—CON.</b>						
Oil cake and oil-cake meal:						
Corn.....pounds..	15,757,612	\$289,547	457,584	\$10,246	562,300	\$16,193
Cottonseed—						
Cake.....do.....	864,862,375	15,059,920	11,045,263	213,542	179,148,955	5,286,428
Meal.....do.....	285,297,316	5,221,091	33,635,530	770,192	132,477,150	3,628,074
Flaxseed or linseed—						
Cake.....do.....	536,984,394	10,252,510	126,184,029	3,210,734	161,088,337	4,753,170
Meal.....do.....						
Other.....do.....	21,558,676	398,681	4,865,602	104,865	60,444,481	1,820,674
Total.....do.....	1,724,460,373	31,221,749	201,403,956	4,994,193	575,421,159	16,668,973
Oils, vegetable:						
Fixed or expressed—						
Corn.....pounds..	8,779,760	998,105	1,831,114	306,219	1,095,414	227,727
Cottonseed.....do.....	158,911,767	19,878,325	100,779,981	18,309,854	178,709,833	36,820,545
Linseed.....gallons..	1,201,554	1,117,895	1,187,850	1,532,307	1,096,304	1,805,291
Other.....do.....		3,004,283		3,951,659		18,496,001
Total fixed or expressed.....		24,998,608		24,100,039		57,349,564
Volatile, or essential—						
Peppermint...pounds..	100,032	218,627	76,247	233,899	65,548	325,070
Other.....do.....		1,062,899		857,044		1,216,870
Total volatile, or essential.....		1,281,526		1,090,943		1,541,940
Total vegetable oils.....		26,280,134		25,190,982		58,891,504
Rice, rice meal, etc.:						
Rice.....pounds..	181,371,560	9,329,877	196,363,268	14,174,513	193,128,025	15,235,762
Rice bran, meal, and polish.....pounds..	750	14				
Rice hulls.....do.....		804				
Total.....do.....		9,330,695		14,174,513		15,235,762
Roots, herbs, and barks, n. e. s.....		852,256		784,514		1,133,855
Seeds:						
Cotton seed.....pounds..	1,001,369	35,434	1,565,052	57,693	1,603,795	65,937
Flaxseed, or linseed, bushels.....	1,017	3,671	21,481	98,165	15,574,	110,142
Grass and clover seed:						
Clover.....pounds..	5,886,893	1,092,515	9,439,314	2,423,776	7,770,582	2,853,262
Timothy.....do.....	15,139,913	937,820	8,520,173	748,164	11,673,229	1,335,602
Other.....do.....	5,666,047	701,101	3,563,556	594,053	3,464,034	641,324
Total grass and clover seed...pounds..	26,692,853	2,731,436	21,523,043	3,765,993	22,907,845	4,830,188
All other seeds.....		1,231,159		1,734,312		2,696,706
Total seeds.....		4,001,700		5,656,163		7,702,973
Spices.....		287,484		507,712		539,313
Spirits, distilled. (See Liquors, alcoholic.)						
Starch:						
Corn.....pounds..	146,423,822	4,721,533	38,659,323	2,220,377	105,726,970	5,333,480
Other.....do.....			35,223,390	2,282,015	38,061,260	2,197,518
Stearin, vegetable.....do.....	1,321,773	179,092	1,226,127	248,585	782,467	166,423
Straw.....long tons..	1,097	12,948				
Sugar, molasses, and sirup:						
Molasses.....gallons..	2,889,991	442,967	3,811,341	847,692	6,123,765	1,277,980
Sirup.....do.....	10,327,503	4,090,150	7,689,938	4,823,912	10,842,832	6,117,329
Sugar, refined...pounds..	1,248,908,286	77,093,685	576,483,050	38,761,686	1,115,865,524	81,569,972
Total sugar, molasses, and sirup.....		81,626,802		44,433,290		88,965,281

TABLE 269.—Agricultural exports (domestic) of the United States during the 3 years ending June 30, 1919—Continued.

Article exported.	Year ending June 30—					
	1917		1918		1919 (preliminary).	
	Quantity.	Value.	Quantity.	Value.	Quantity.	Value.
VEGETABLE MATTER—con.						
Tobacco:						
Leaf.....pounds..	406,431,021	\$59,788,154	288,781,511	\$69,674,731	625,304,513	\$189,896,797
Stems and trimmings, pounds.....	5,167,839	166,153	389,175	24,964	4,215,070	395,889
Total.....pounds..	411,598,860	59,954,307	289,170,686	69,699,695	629,519,583	190,292,686
Vegetables:						
Fresh or dried—						
Beans.....bushels..	<sup>1</sup> 2,164,943	<sup>1</sup> 10,427,742	1,517,458	9,096,559	4,484,220	25,175,154
Onions.....do.....	409,301	749,959	534,192	788,584	842,225	1,767,180
Peas.....do.....	( <sup>2</sup> )	( <sup>2</sup> )	266,824	1,436,816	498,405	2,811,818
Potatoes.....do....	2,489,001	3,514,379	3,453,307	4,946,467	3,688,840	6,084,663
Total fresh or dried, bushels.....	5,063,245	14,692,080	5,771,781	16,268,426	9,513,690	35,838,815
Prepared or preserved—						
Canned—						
Corn.....				479,370		229,887
Soups.....		4,765,136		1,189,129		1,518,646
Tomatoes.....				963,354		1,146,999
Other.....				4,560,820		10,613,030
Total canned.....		4,765,136		7,192,673		13,508,562
Pickles and sauces.....		821,151		1,084,330		1,269,783
Other.....		2,012,343		2,429,272		2,896,634
Total prepared or preserved.....		7,598,630		10,706,275		17,674,979
Total vegetables.....		22,290,710		26,974,701		53,513,794
Vinegar, gallons.....	284,817	47,996	292,413	73,451	286,903	90,261
Wines. (See Liquors, alcoholic.)						
Yeast.....		1,021,651		918,842		1,116,690
Total vegetable mat- ter, including forest products.....		1,522,472,743		1,642,105,828		2,476,896,227
Total vegetable mat- ter, excluding forest products.....		1,453,553,907		1,554,925,060		2,369,843,855
Total agricultural ex- ports, including for- est products.....		2,037,171,124		2,368,646,538		3,690,222,040
Total agricultural ex- ports, excluding forest products.....		1,968,252,288		2,280,465,770		3,583,169,668

<sup>1</sup> Including peas.<sup>2</sup> Included in beans.

TABLE 270.—Foreign trade of the United States in agricultural products, 1852-1919.

[Compiled from reports of Foreign Commerce and Navigation of the United States. All values are gold.]

Year ending June 30—	Agricultural exports. <sup>1</sup>			Agricultural imports. <sup>1</sup>		Excess of agricultural exports (+).
	Domestic.		Foreign.	Total.	Percentage of all imports.	
	Total.	Percentage of all exports.				
Average:						
1852-1856.....	\$164,895,146	80.9	\$8,059,875	\$77,847,153	29.1	+\$95,107,863
1857-1861.....	215,708,845	81.1	10,173,833	121,018,143	38.2	+104,864,535
1862-1866.....	148,865,540	75.7	9,287,669	122,221,547	43.0	+35,931,662
1867-1871.....	250,713,058	76.9	8,538,101	179,774,000	42.3	+79,477,159
1872-1876.....	396,666,397	78.5	8,853,247	263,155,573	46.5	+142,364,071
1877-1881.....	591,350,518	80.4	8,631,780	266,383,702	50.4	+333,598,596
1882-1886.....	557,472,922	76.3	9,340,463	311,707,564	46.8	+255,105,821
1887-1891.....	573,286,616	74.7	6,982,328	366,950,109	43.3	+213,318,835
1892-1896.....	638,748,318	73.0	8,446,491	398,332,043	51.6	+248,862,766
1897-1901.....	827,566,147	65.9	10,961,539	376,549,697	50.2	+461,977,989
1902-1906.....	879,541,247	59.5	11,922,292	487,881,038	46.3	+403,582,501
1907-1911.....	975,398,554	53.9	12,126,228	634,570,734	45.2	+352,954,048
1901.....	951,628,331	65.2	11,293,045	391,931,051	47.6	+570,990,325
1902.....	857,113,533	63.2	10,308,306	413,744,557	45.8	+453,677,282
1903.....	878,480,557	63.1	13,505,343	456,199,325	44.5	+435,786,575
1904.....	859,160,264	59.5	12,625,036	461,434,851	46.6	+410,350,439
1905.....	826,904,777	55.4	12,316,525	553,851,214	49.6	+285,370,088
1906.....	976,047,104	56.8	10,856,259	554,175,242	45.2	+432,728,121
1907.....	1,054,405,416	56.9	11,613,519	626,836,808	43.7	+439,182,127
1908.....	1,017,396,404	55.5	10,298,514	539,690,121	45.2	+488,004,797
1909.....	903,238,122	55.1	9,584,934	638,612,692	48.7	+274,210,364
1910.....	871,158,425	50.9	14,469,627	687,509,115	44.2	+198,118,937
1911.....	1,030,794,402	51.2	14,664,548	680,204,932	44.5	+365,254,018
1912.....	1,050,627,131	48.4	12,107,656	783,457,471	47.4	+279,277,316
1913.....	1,123,651,985	46.3	15,029,444	815,300,510	45.0	+323,380,919
1914.....	1,113,973,635	47.8	17,729,462	924,247,116	48.8	+207,456,481
1915.....	1,475,937,607	54.3	34,420,077	910,786,289	54.4	+599,571,395
1916.....	1,518,071,450	35.5	42,087,535	1,189,704,830	54.1	+370,454,155
1917.....	1,968,253,288	31.6	37,640,245	1,404,972,108	52.8	+600,921,425
1918.....	2,280,465,770	38.5	39,552,557	1,618,873,978	55.0	+701,144,349
1919 (preliminary).....	3,583,169,668	50.7	103,558,126	1,782,435,788	57.6	+1,904,292,006

<sup>1</sup> Not including forest products.

TABLE 271.—Value of principal groups of farm and forest products exported from and imported into the United States, 1917-1919.

[Compiled from reports on the Foreign Commerce of the United States.]

Article.	Exports (domestic merchandise).			Imports.		
	Year ending June 30—					
	1917	1918	1919 (prel.)	1917	1918	1919 (prel.)
<b>FARM PRODUCTS.</b>						
<b>ANIMAL MATTER.</b>						
Animals, live.....	\$89,382,853	\$21,733,594	\$10,718,851	\$16,602,859	\$21,958,378	\$40,924,766
Dairy products.....	49,379,473	85,910,866	122,160,943	7,071,113	8,380,393	6,329,829
Eggs.....	7,568,911	7,167,134	12,449,345	268,286	483,636	233,003
Feathers and downs, crude.....	368,862	302,236	521,747	1,479,216	1,959,180	1,435,508
Fibers, animal:						
Silk.....	13,418	.....	.....	160,571,808	190,624,766	217,517,484
Wool.....	1,230,296	916,506	550,772	131,137,170	198,545,911	224,410,062
Packing-house products.....	363,973,124	604,327,984	1,058,861,223	239,129,197	176,037,857	215,398,770
Other animal matter.....	2,781,444	5,182,390	8,062,932	4,203,659	6,016,153	6,078,649
<b>Total animal matter..</b>	<b>514,698,381</b>	<b>725,540,710</b>	<b>1,213,825,813</b>	<b>560,463,308</b>	<b>604,006,274</b>	<b>712,328,066</b>
<b>VEGETABLE MATTER.</b>						
Argols or wine lees.....	.....	.....	.....	3,824,882	5,443,628	5,281,794
Cocoa and chocolate.....	3,451,519	5,898,431	10,835,409	40,387,418	41,372,378	36,009,940
Coffee.....	6,844,863	6,286,180	8,451,592	133,184,000	103,058,536	143,089,619
Cotton.....	543,074,690	665,024,655	863,161,409	40,429,526	36,020,483	37,633,612
Fibers, vegetable, other.....	.....	.....	.....	67,709,758	109,042,470	103,872,080
Fruits.....	37,399,309	32,207,364	69,144,187	25,315,951	24,408,810	25,816,703
Ginseng.....	1,386,203	1,717,548	2,057,232	.....	.....	.....
Glucose and grape sugar..	7,358,731	5,994,671	7,464,052	.....	.....	.....
Grain and grain products.	585,534,850	623,907,546	946,131,149	49,396,371	76,292,626	27,244,293
Hay.....	1,685,836	907,401	864,922	628,021	4,618,764	3,677,025
Hops.....	773,926	993,773	2,333,850	59,291	72,450	14
Indigo.....	.....	.....	.....	4,108,910	3,895,114	1,551,467
Licorice root.....	.....	.....	.....	2,190,822	1,853,927	3,445,022
Liquors, alcoholic.....	20,883,227	8,836,678	12,911,968	17,679,132	11,655,093	2,119,422
Nursery stock (plants, trees, etc.).....	220,341	260,763	333,356	3,964,513	3,328,700	2,363,553
Nuts.....	1,740,508	2,263,314	2,148,626	32,875,686	52,850,788	42,515,661
Oil cake and oil cake meal.....	31,221,749	4,994,193	16,668,973	554,871	574,032	2,579,526
Oil, vegetable.....	26,280,134	25,190,982	58,891,504	47,013,967	92,357,322	112,631,665
Opium, crude.....	.....	.....	.....	843,418	2,443,228	5,166,058
Rice, rice flour, meal, and broken rice.....	9,330,695	14,174,513	15,235,762	5,773,797	16,311,705	17,885,989
Sago, tapioca, etc.....	.....	.....	.....	3,712,956	5,530,889	2,730,278
Seeds.....	4,001,700	5,656,163	7,702,973	35,879,665	50,841,623	35,212,664
Spices.....	287,484	507,712	539,313	7,745,022	11,519,313	12,190,560
Starch.....	4,721,532	4,502,392	7,530,998	973,530	1,673,477	1,042,469
Sugar, molasses, and sirup	81,626,802	44,433,290	88,965,281	241,892,265	246,193,204	316,874,374
Tea.....	.....	.....	.....	19,265,264	30,889,030	24,390,722
Tobacco.....	59,954,307	69,699,695	190,292,686	25,922,655	46,985,865	66,329,689
Vanilla beans.....	.....	.....	.....	1,662,578	1,475,676	1,677,316
Vegetables.....	22,290,710	26,974,701	53,513,794	29,150,889	30,175,769	33,687,305
Wax, vegetable.....	.....	.....	.....	1,739,199	2,693,258	3,011,559
Other vegetable matter...	3,485,790	4,493,095	4,664,819	624,443	1,289,546	77,343
<b>Total vegetable mat- ter.....</b>	<b>1,453,554,907</b>	<b>1,554,925,060</b>	<b>2,369,843,855</b>	<b>844,508,800</b>	<b>1,014,867,704</b>	<b>1,070,107,722</b>
<b>Total farm products..</b>	<b>1,968,253,288</b>	<b>2,280,465,770</b>	<b>3,583,169,668</b>	<b>1,404,972,108</b>	<b>1,618,873,978</b>	<b>1,782,435,788</b>
<b>FOREST PRODUCTS.</b>						
Cork wood or cork bark...	.....	.....	.....	3,870,389	3,061,827	1,736,102
Dyewoods, and extracts of.....	( <sup>1</sup> )	2,339,480	1,556,023	4,479,195	2,238,115	972,533
Gums, rubber.....	.....	.....	.....	193,118,855	206,543,236	161,192,551
Gums, other than rubber.	.....	.....	.....	21,510,283	21,685,638	21,786,997
Naval stores.....	15,581,208	11,172,864	17,777,479	8,691	636	.....
Tanning materials, n. e. s..	3,958,380	3,810,420	3,295,098	7,930,698	6,672,468	6,852,423

<sup>1</sup> Not stated.

TABLE 271.—Value of principal groups of farm and forest products exported from and imported into the United States, 1917-1919—Continued.

Article.	Exports (domestic merchandise).			Imports.		
	Year ending June 30—					
	1917	1918	1919 (prel.)	1917	1918	1919 (prel.)
<b>FOREST PRODUCTS—Con.</b>						
<b>Wood:</b>						
Cabinet, unsawed.....				\$4,266,852	\$5,045,463	\$5,826,276
Lumber.....	\$41,070,973	\$59,919,934	\$76,510,836	32,093,905	40,405,720	37,468,195
Pulp wood.....				6,889,123	11,088,422	13,708,447
Timber and logs.....	5,202,250	3,959,354	4,143,522	1,270,348	815,247	765,368
Rattan and reeds.....				1,171,052	1,781,239	867,340
Wood pulp.....	2,018,639	3,531,304	2,193,133	42,461,994	31,589,090	29,581,103
Other forest products.....	1,087,386	2,447,412	1,576,263	3,628,045	4,106,358	3,927,107
Total forest products.....	68,918,836	87,180,768	107,052,372	322,699,430	335,033,459	284,684,442
Total farm and forest products.....	2,037,172,124	2,367,646,538	3,690,222,040	1,727,671,538	1,953,907,437	2,067,120,23

TABLE 272.—Exports of selected domestic agricultural products, 1852-1919.

[Compiled from reports of Foreign Commerce and Navigation of the United States. Where figures are lacking, either there were no exports or they were not separately classified for publication. "Beef, salted or pickled," and "Pork, salted or pickled," barrels, 1851-1865, were reduced to pounds at the rate of 200 pounds per barrel, and tierces, 1855-1865, at the rate of 300 pounds per tierce; cottonseed oil, 1910, pounds reduced to gallons at the rate of 7.5 pounds per gallon. It is assumed that 1 barrel of corn meal is the product of 4 bushels of corn, and 1 barrel of wheat flour the product of 5 bushels of wheat prior to 1880 and 4½ bushels of wheat in 1880 and subsequently.]

Year ending June 30—	Cattle.	Cheese.	Packing-house products.				Beef and its products—total, as far as ascertainable. <sup>1</sup>
			Beef, cured—salted or pickled.	Beef, fresh.	Beef oils—oleo oil.	Beef tallow.	
Average:	Number.	Pounds.	Pounds.	Pounds.	Pounds.	Pounds.	Pounds.
1852-1856..	1,431	6,200,385	25,980,520			7,468,910	33,449,430
1857-1861..	20,294	13,906,430	26,985,880			13,214,614	40,200,494
1862-1866..	6,531	42,683,073	27,662,720			43,202,724	70,865,444
1867-1871..		52,880,978	26,954,656			27,577,269	54,531,925
1872-1876..	45,672	87,173,752	35,826,646			78,994,360	114,821,006
1877-1881..	127,045	129,670,479	40,174,643	69,601,120		96,822,695	218,709,987
1882-1886..	131,605	108,790,010	47,401,470	97,327,819	30,276,133	48,745,416	225,625,631
1887-1891..	244,394	86,354,842	65,613,851	136,447,554	50,482,249	91,608,126	411,797,859
1892-1896..	349,032	66,905,798	64,898,780	207,372,575	102,038,519	56,976,840	507,177,430
1897-1901..	415,488	46,108,704	52,242,288	305,626,184	139,373,402	86,082,497	637,268,235
1902-1906..	508,103	19,244,482	59,208,292	272,148,180	156,925,317	59,892,601	622,843,230
1907-1911..	253,867	9,152,083	46,187,175	144,799,735	170,530,432	66,356,232	448,024,017
1901.....	459,218	39,813,517	55,312,632	351,748,333	161,651,413	77,166,889	705,104,772
1902.....	392,884	27,203,184	48,632,727	301,824,473	138,546,088	34,065,758	596,254,520
1903.....	402,178	18,987,178	52,801,220	254,795,963	126,010,339	27,368,924	546,055,244
1904.....	593,409	23,335,172	57,584,710	299,579,671	165,183,839	76,924,174	663,147,095
1905.....	567,806	10,134,424	55,934,705	236,486,568	145,228,245	63,536,992	575,874,718
1906.....	584,239	16,562,451	81,088,098	268,054,227	209,658,075	97,567,156	732,884,572
1907.....	423,051	17,285,230	62,645,281	281,651,502	195,337,176	127,857,739	689,752,420
1908.....	349,210	8,439,031	46,958,367	201,154,105	212,541,157	91,397,507	579,303,478
1909.....	207,542	6,822,842	44,494,210	122,952,671	179,985,246	53,332,767	418,844,332
1910.....	139,430	2,846,709	36,554,266	75,729,666	126,091,675	29,379,992	286,295,874
1911.....	150,100	10,366,605	40,283,749	42,510,731	138,696,906	29,813,154	265,923,983
1912.....	105,506	6,337,559	38,087,907	15,264,320	126,467,124	39,451,419	233,924,626
1913.....	24,714	2,599,058	25,856,919	7,362,388	92,849,757	30,586,350	170,208,320
1914.....	18,376	2,427,577	23,265,974	6,394,404	97,017,065	15,812,831	151,212,009
1915.....	5,484	55,362,917	31,874,743	170,440,934	80,481,946	20,239,988	394,980,962
1916.....	21,287	44,394,301	38,114,682	231,214,000	102,645,914	16,288,743	457,555,572
1917.....	13,387	66,050,013	58,053,667	197,177,101	67,110,111	15,209,369	423,673,997
1918.....	18,213	44,303,076	54,467,910	370,032,900	56,603,388	5,014,964	600,132,371
1919 (prel.)..	42,345	18,794,853	45,067,861	332,205,176	59,092,322	16,210,997	591,173,312

<sup>1</sup> Includes canned, cured, and fresh beef, oleo oil, oleomargarine, tallow and stearin from animal fats.

TABLE 272.—Exports of selected domestic agricultural products, 1852-1919—Continued.

Year ending June 30—	Packing-house products.					Apples, fresh.	Corn and corn meal (in terms of grain).
	Pork, cured— bacon.	Pork, cured— hams and shoulders.	Pork, cured— salted or pickled.	Pork— lard.	Pork and its products— total, as far as ascertain- able. <sup>1</sup>		
Average:	<i>Pounds.</i>	<i>Pounds.</i>	<i>Pounds.</i>	<i>Pounds.</i>	<i>Pounds.</i>	<i>Barrels.</i>	<i>Bushels.</i>
1852-1856..	30,005,479	.....	40,542,600	33,354,976	103,903,056	37,412	7,123,286
1857-1861..	30,583,297	.....	34,854,400	37,965,993	103,403,690	57,045	6,557,610
1862-1866..	10,796,961	.....	52,550,758	89,138,251	252,485,970	119,433	12,059,794
1867-1871..	45,790,113	.....	28,879,085	53,579,373	128,248,571	.....	9,924,235
1872-1876..	313,402,401	.....	60,429,361	194,197,714	568,029,477	132,756	38,560,557
1877-1881..	643,633,709	.....	85,968,138	331,457,591	1,075,793,475	509,735	88,190,030
1882-1886..	355,905,444	47,634,675	72,354,682	263,425,058	739,455,913	401,886	49,992,203
1887-1891..	419,935,416	60,697,365	73,984,682	381,388,854	936,247,966	522,511	54,606,273
1892-1896..	438,847,549	96,107,152	64,827,470	451,547,135	1,052,133,700	520,810	63,979,898
1897-1901..	536,287,266	200,853,226	112,788,498	652,418,143	1,528,138,779	779,980	192,531,378
1902-1906..	292,721,953	206,902,427	116,823,284	592,130,894	1,242,136,649	1,368,608	74,615,465
1907-1911..	209,005,144	189,603,211	90,809,879	519,746,378	1,028,996,659	1,225,655	56,568,030
1901.....	456,122,741	216,571,803	138,643,611	611,357,514	1,462,369,849	883,673	181,405,473
1902.....	383,150,624	227,653,232	115,896,275	556,840,222	1,337,315,909	459,719	28,028,688
1903.....	207,336,000	214,183,365	95,287,374	490,755,821	1,042,119,570	1,656,129	76,639,261
1904.....	249,665,941	194,948,864	112,224,861	561,302,643	1,146,255,441	2,018,262	58,222,061
1905.....	262,246,635	203,458,724	118,887,189	610,238,899	1,220,031,970	1,499,942	90,293,483
1906.....	361,210,563	194,210,949	141,820,720	741,516,886	1,464,960,356	1,208,989	119,893,833
1907.....	250,418,699	209,481,496	166,427,409	627,559,660	1,268,065,412	1,539,267	86,368,228
1908.....	241,189,929	221,769,634	149,505,937	603,413,770	1,237,210,760	1,049,545	55,063,860
1909.....	244,578,674	212,170,224	52,354,980	528,722,933	1,053,142,056	896,279	37,665,040
1910.....	152,163,107	146,885,385	40,031,599	362,927,671	707,110,062	922,078	38,128,498
1911.....	156,675,310	157,709,316	45,729,471	476,107,857	879,455,006	1,721,106	65,614,522
1912.....	208,574,208	204,044,491	56,321,469	532,255,865	1,071,951,724	1,456,381	41,797,291
1913.....	200,993,584	159,544,687	53,749,023	519,025,384	984,696,710	2,150,132	50,780,143
1914.....	193,964,252	165,881,791	45,543,085	481,457,792	921,913,029	1,506,569	10,725,819
1915.....	346,718,227	203,701,114	45,655,574	475,531,908	1,106,180,488	2,351,501	50,668,303
1916.....	579,808,786	282,208,611	63,460,713	427,011,338	1,462,697,062	1,466,321	39,896,928
1917.....	667,151,972	266,656,581	46,992,721	444,769,540	1,501,948,125	1,739,997	66,753,294
1918.....	815,294,424	419,571,869	33,221,502	392,506,355	1,692,124,323	635,409	49,073,263
1919 (prel.)..	1,239,540,973	667,848,019	31,504,497	725,577,868	2,707,403,666	1,576,748	23,020,846

Year ending June 30—	Lard com- pounds.	Cotton.	Glucose and grape sugar.	Corn-oil cake and oil-cake meal.	Cottonseed- oil cake and oil-cake meal.	Prunes.	Tobacco.
Average:	<i>Pounds.</i>	<i>Pounds.</i>	<i>Pounds.</i>	<i>Pounds.</i>	<i>Pounds.</i>	<i>Pounds.</i>	<i>Pounds.</i>
1852-1856..	.....	1,110,498,083	.....	.....	.....	.....	140,183,800
1857-1861..	.....	1,125,715,497	.....	.....	.....	.....	167,710,800
1862-1866..	.....	137,582,133	.....	.....	.....	.....	140,207,850
1867-1871..	.....	902,410,338	.....	.....	.....	.....	194,753,537
1872-1876..	.....	1,248,805,497	.....	.....	.....	.....	241,848,410
1877-1881..	.....	1,738,892,268	.....	.....	.....	.....	266,315,190
1882-1886..	.....	1,968,178,266	4,473,550	.....	.....	.....	237,941,913
1887-1891..	.....	2,439,650,456	27,686,298	.....	.....	.....	259,248,361
1892-1896..	.....	2,736,655,351	125,574,007	.....	.....	.....	281,746,279
1897-1901..	21,792,477	3,447,909,578	209,279,772	.....	1,005,099,895	.....	304,401,701
1902-1906..	52,554,358	3,632,267,952	154,866,980	21,888,135	1,066,790,196	48,550,774	325,538,515
1907-1911..	75,765,254	4,004,770,051	145,064,738	61,732,807	989,738,130	47,039,287	334,395,923
1901.....	23,359,966	3,359,062,360	204,209,974	12,703,209	1,258,687,317	10,021,564	315,787,782
1902.....	36,201,744	3,528,974,636	130,419,611	14,740,498	1,050,466,246	23,358,849	301,007,365
1903.....	46,130,004	3,569,141,969	126,239,981	8,093,222	1,100,392,988	66,385,215	368,184,084
1904.....	53,603,545	3,089,855,906	152,768,716	14,014,885	820,349,073	73,146,214	311,971,831
1905.....	61,215,187	4,339,322,077	175,250,580	24,171,127	1,251,907,996	54,993,849	334,302,091
1906.....	67,621,310	3,634,045,170	189,656,011	48,420,942	1,110,834,678	24,869,744	312,227,202
1907.....	80,148,861	4,518,217,220	151,629,441	56,808,972	1,340,967,136	44,400,104	340,742,864
1908.....	75,183,210	3,816,998,693	129,686,834	66,127,704	929,287,467	28,148,450	330,812,658
1909.....	75,183,196	4,447,985,202	112,224,504	53,233,890	1,233,750,327	22,602,288	287,900,946
1910.....	74,556,603	3,206,708,226	149,820,088	49,108,598	640,088,766	89,014,880	357,196,074
1911.....	73,754,400	4,033,940,915	181,963,046	83,384,870	804,596,955	51,030,711	355,327,072
1912.....	62,522,888	5,535,125,429	171,156,259	72,490,021	1,293,690,138	74,328,074	379,845,320
1913.....	67,456,832	4,562,295,675	200,149,246	76,262,845	1,128,092,367	117,950,875	418,796,906
1914.....	58,303,564	4,760,940,538	199,530,874	59,030,623	799,974,252	69,813,711	449,749,982
1915.....	69,980,614	4,403,578,499	158,462,508	45,026,125	1,479,065,015	43,478,892	348,346,091
1916.....	52,843,311	3,084,070,125	186,406,182	18,996,490	1,057,221,569	57,422,827	443,293,156
1917.....	56,359,493	3,088,080,786	214,973,315	15,757,612	1,150,159,691	59,645,141	411,598,860
1918.....	31,278,382	2,320,511,665	97,858,301	457,584	44,680,793	32,926,546	289,170,686
1919 (prel.)..	131,750,503	2,733,683,125	136,230,373	562,300	311,626,105	59,072,436	629,519,583

<sup>1</sup> Includes canned, fresh, salted, or pickled pork, lard, neutral lard, lard oil, bacon, and hams.

TABLE 272—Exports of selected domestic agricultural products, 1852-1919—Continued.

Year ending June 30—	Hops.	Oils, vegetable— cotton-seed oil.	Rice and rice bran, meal, and polish.	Sugar, raw and refined.	Wheat.	Wheat flour.	Wheat and wheat flour (in terms of grain).
<b>Average:</b>	<i>Pounds.</i>	<i>Gallons.</i>	<i>Pounds.</i>	<i>Pounds.</i>	<i>Bushels.</i>	<i>Barrels.</i>	<i>Bushels.</i>
1852-1856..	1,162,802	.....	56,514,840	7,730,322	4,715,021	2,891,562	19,172,830
1857-1861..	2,216,095	.....	65,732,080	6,015,058	12,378,351	3,318,280	28,969,749
1862-1866..	4,719,330	.....	2,257,860	3,007,777	22,529,735	3,530,757	40,183,518
1867-1871..	6,486,616	.....	1,856,948	4,356,900	22,106,833	2,585,115	35,032,409
1872-1876..	3,446,466	547,450	391,344	20,142,169	48,957,518	3,415,871	66,036,873
1877-1881..	10,445,654	4,498,436	602,442	41,718,443	107,780,556	5,375,583	133,262,753
1882-1886..	9,584,437	3,467,905	561,406	107,129,770	82,883,913	8,620,199	121,674,809
1887-1891..	7,184,147	7,120,796	3,209,653	75,073,838	64,739,011	11,286,568	115,528,568
1892-1896..	15,146,667	15,782,647	10,277,947	13,999,349	99,913,895	15,713,279	170,623,652
1897-1901..	15,467,314	42,863,203	18,407,139	11,213,664	120,247,430	17,151,070	197,427,246
1902-1906..	11,476,272	38,605,737	45,977,670	14,807,014	70,527,077	15,444,100	140,025,529
1907-1911..	14,774,185	38,783,550	27,194,549	61,429,802	62,854,580	11,840,699	116,137,728
1901.....	14,963,676	49,356,741	25,527,846	8,874,860	132,060,667	18,650,979	215,990,073
1902.....	10,715,151	33,042,848	29,591,274	7,572,452	154,856,102	17,759,203	234,772,516
1903.....	7,794,705	35,642,994	19,750,448	10,520,156	114,181,420	19,716,484	202,905,598
1904.....	10,985,988	29,013,743	29,121,763	15,418,537	44,230,169	16,999,432	120,727,613
1905.....	14,858,612	51,535,580	113,282,760	18,348,077	4,394,402	8,826,335	44,112,910
1906.....	13,026,904	43,793,519	38,142,103	22,175,846	34,973,291	13,919,048	97,609,007
1907.....	16,809,534	41,880,304	30,174,371	21,237,603	76,569,423	15,584,667	146,700,425
1908.....	22,920,480	41,019,991	28,444,415	25,510,643	100,371,057	13,927,247	163,043,669
1909.....	10,446,884	51,087,329	20,511,429	79,946,297	66,923,244	10,521,161	114,268,468
1910.....	10,589,254	29,860,667	26,779,188	125,507,022	46,679,876	9,040,987	87,364,318
1911.....	13,104,774	30,069,459	30,063,341	54,947,444	23,729,302	10,129,435	69,311,760
1912.....	12,190,663	53,262,796	39,446,571	79,594,034	30,160,212	11,006,487	79,689,404
1913.....	17,591,195	42,031,052	38,908,057	43,994,761	91,602,974	11,394,805	141,132,166
1914.....	24,262,896	25,728,411	22,414,326	50,895,726	92,393,775	11,821,461	145,590,349
1915.....	16,210,443	42,448,870	77,480,065	549,007,411	259,642,533	16,182,765	332,464,975
1916.....	22,409,818	35,534,941	121,967,465	1,630,150,863	173,274,015	15,520,669	243,117,025
1917.....	4,824,876	21,188,236	181,372,310	1,248,908,286	149,831,427	11,942,778	203,573,928
1918.....	3,494,579	13,437,331	196,363,268	576,483,050	34,118,853	21,879,951	132,578,633
1919 (prel.)..	7,466,952	23,827,978	193,128,025	1,115,865,524	178,582,673	24,190,092	287,438,087

TABLE 273.—Imports of selected agricultural products, 1852-1919.

[Compiled from reports of Foreign Commerce and Navigation of the United States. Where figures are lacking, either there were no imports or they were not separately classified for publication. "Silk" includes, prior to 1881, only "Silk, raw or as reeled from the cocoon;" in 1881 and 1882 are included this item and "Silk waste;" after 1882, both these items and "Silk cocoons." From "Cocoa and chocolate" are omitted in 1860, 1861, and 1872 to 1881, small quantities of chocolate, the official returns for which were given only in value. "Jute and jute butts" includes in 1858 and 1859 an unknown quantity of "Sisal grass, coir, etc.," and in 1865-1868 an unknown quantity of "Hemp." Cattle hides are included in "Hides and skins other than cattle and goat" in 1895-1897. Olive oil for table use includes in 1862-1864 and 1885-1905 all olive oil. Sisal grass includes in 1884-1890 "Other vegetable substances." Hemp includes in 1885-1888 all substitutes for hemp.]

Year ending June 30—	Cheese.	Silk.	Wool.	Almonds.	Argols or wine lees.	Cocoa and chocolate, total.	Coffee.
<b>Average:</b>	<i>Pounds.</i>	<i>Pounds.</i>	<i>Pounds.</i>	<i>Pounds.</i>	<i>Pounds.</i>	<i>Pounds.</i>	<i>Pounds.</i>
1852-1856..	1,053,983	.....	19,067,447	3,460,807	.....	2,486,572	196,582,863
1857-1861..	1,378,147	.....	.....	3,251,091	.....	3,063,893	216,235,090
1862-1866..	.....	.....	.....	2,482,063	1,354,947	2,453,141	124,551,992
1867-1871..	.....	681,669	.....	.....	2,360,529	3,502,614	248,726,019
1872-1876..	.....	1,094,948	.....	.....	4,951,473	4,857,364	307,006,928
1877-1881..	.....	1,922,269	62,744,282	.....	12,403,256	6,315,488	384,282,199
1882-1886..	.....	4,672,846	83,293,800	.....	17,551,967	11,568,173	529,578,782
1887-1891..	8,335,323	6,564,121	117,763,889	5,860,728	21,433,570	18,322,049	509,367,994
1892-1896..	9,649,752	8,382,892	162,640,491	7,487,676	26,469,990	25,475,234	597,484,217
1897-1901..	12,588,515	10,962,210	163,979,079	7,361,198	24,379,847	38,209,423	816,570,082
1902-1906..	22,165,754	17,187,544	193,656,402	10,920,881	27,647,440	70,901,254	980,119,167
1907-1911..	37,662,812	22,143,461	199,562,649	15,297,414	29,350,692	113,673,368	934,533,322
1901.....	15,329,099	10,405,555	103,583,505	5,140,232	28,598,781	47,620,204	854,871,310
1902.....	17,067,714	14,234,826	166,576,966	9,868,982	29,276,148	52,878,587	1,091,004,252
1903.....	20,671,384	15,270,859	177,137,796	8,142,164	29,966,557	65,046,884	915,086,380
1904.....	22,707,103	16,722,709	173,742,834	9,838,852	24,571,730	75,070,746	995,043,284
1905.....	23,095,705	22,357,307	249,135,746	11,745,081	26,281,931	77,383,024	1,047,792,984
1906.....	27,286,866	17,352,021	201,688,668	15,009,326	28,140,835	84,127,027	851,668,933
1907.....	33,848,766	18,743,904	203,847,545	14,233,613	30,540,893	97,059,513	985,321,473
1908.....	32,530,830	16,662,132	125,980,524	17,144,968	26,738,834	86,604,684	890,640,057
1909.....	35,548,143	25,187,957	266,409,304	11,029,421	32,115,646	132,660,931	1,049,868,768
1910.....	40,817,524	23,457,223	263,928,232	18,556,356	28,182,956	111,070,834	871,469,516



TABLE 273.—Imports of selected agricultural products, 1852-1919—Continued.

Year ending June 30—	Cheese.	Silk.	Wool.	Almonds.	Argols or wine lees.	Cocoa and chocolate, total.	Coffee.
	<i>Pounds.</i>	<i>Pounds.</i>	<i>Pounds.</i>	<i>Pounds.</i>	<i>Pounds.</i>	<i>Pounds.</i>	<i>Pounds.</i>
1911.....	45,568,797	26,666,091	137,647,641	15,522,712	29,175,133	140,970,877	875,366,797
1912.....	46,542,007	26,584,962	193,400,713	17,231,458	23,661,078	148,785,846	885,201,247
1913.....	49,387,944	32,101,555	195,293,255	15,670,558	29,479,119	143,509,852	863,130,757
1914.....	63,784,313	34,545,829	247,648,869	19,038,405	29,793,011	179,364,091	1,001,528,317
1915.....	50,138,520	31,052,674	308,083,429	17,111,264	28,624,554	194,734,195	1,118,690,524
1916.....	30,087,999	41,925,297	534,828,022	16,596,921	34,721,043	245,579,101	1,201,104,485
1917.....	14,481,514	40,351,423	372,372,218	23,424,058	23,925,808	340,483,397	1,319,870,802
1918.....	9,839,305	43,680,988	379,129,934	23,840,145	30,267,382	399,312,278	1,143,890,889
1919 (prel.)..	2,442,306	50,068,643	422,414,664	30,328,427	32,228,216	313,037,419	1,046,029,274

Year ending June 30—	Flax.	Hemp.	Hops.	Jute and jute butts.	Licorice root.	Manila.	Molasses.
	<i>Long tons.</i>	<i>Long tons.</i>	<i>Pounds.</i>	<i>Long tons.</i>	<i>Pounds.</i>	<i>Long tons.</i>	<i>Gallons.</i>
Average:							
1852-1856..	1,143	1,574	.....	3,244	.....	12,084	28,488,888
1857-1861..	.....	2,652	.....	17,239	1,372,573	.....	30,190,875
1862-1866..	.....	.....	.....	3,213	1,887,892	15,566	34,262,933
1867-1871..	.....	.....	.....	14,909	.....	.....	53,322,088
1872-1876..	4,170	22,711	.....	49,188	.....	.....	44,815,321
1877-1881..	4,260	22,458	.....	62,496	.....	.....	32,638,963
1882-1886..	5,678	30,557	1,618,879	91,058	.....	.....	35,019,689
1887-1891..	7,021	36,919	7,771,672	104,887	59,275,373	.....	30,543,299
1892-1896..	6,785	5,409	2,386,240	84,111	86,444,974	47,354	15,474,619
1897-1901..	7,008	4,107	2,381,899	93,970	87,475,620	47,217	6,321,160
1902-1906..	8,574	5,230	5,205,867	101,512	99,543,395	60,813	17,191,821
1907-1911..	9,721	6,368	6,769,965	100,420	96,111,469	67,289	24,147,348
1901.....	6,878	4,057	2,606,708	103,140	100,105,654	43,735	11,453,156
1902.....	7,772	6,054	2,805,293	128,963	109,077,323	56,453	14,391,215
1903.....	8,155	4,919	6,012,510	79,703	88,580,611	61,648	17,240,399
1904.....	10,123	5,871	2,758,163	96,735	89,463,182	65,666	18,828,530
1905.....	8,089	3,987	4,339,379	98,215	108,443,892	61,562	19,477,885
1906.....	8,729	5,317	10,113,989	103,945	102,151,969	58,738	16,021,076
1907.....	8,656	8,718	6,211,893	104,489	66,115,863	54,513	24,630,935
1908.....	9,528	6,213	8,493,265	107,533	109,355,720	52,467	18,882,756
1909.....	9,870	5,208	7,386,574	156,685	97,742,776	61,902	22,092,696
1910.....	12,761	6,423	3,200,560	68,155	82,207,496	93,253	31,292,165
1911.....	7,792	5,278	8,557,531	65,238	125,135,490	47,308	23,838,190
1912.....	10,900	5,007	2,991,125	101,001	74,582,225	68,536	28,828,213
1913.....	12,421	7,663	8,494,144	125,389	105,116,227	73,823	33,926,521
1914.....	9,885	8,822	5,382,025	106,033	115,636,131	49,688	51,410,271
1915.....	4,694	5,310	11,651,332	83,140	65,958,501	51,081	70,839,623
1916.....	6,939	6,506	675,704	108,322	41,003,295	78,892	85,716,673
1917.....	7,918	9,635	236,849	112,695	59,400,224	76,765	110,237,888
1918.....	5,607	6,813	121,288	78,312	26,982,932	86,220	130,730,861
1919 (prel.)..	8,659	2,410	6	53,218	42,684,025	67,844	130,074,717

Year ending June 30—	Olive oil, for table use.	Opium, crude.	Potatoes.	Rice, and rice flour, rice meal, and broken rice.	Sisal grass.	Sugar, raw and refined.	Tea.
	<i>Gallons.</i>	<i>Pounds.</i>	<i>Bushels.</i>	<i>Pounds.</i>	<i>Long tons.</i>	<i>Pounds.</i>	<i>Pounds.</i>
Average:							
1852-1856..	.....	110,143	406,611	.....	.....	479,373,648	24,959,922
1857-1861..	.....	113,594	.....	.....	.....	691,323,833	28,149,643
1862-1866..	177,947	128,590	251,637	70,893,331	615	672,637,141	30,869,450
1867-1871..	152,827	209,096	216,077	52,953,577	.....	1,138,464,815	44,052,805
1872-1876..	174,555	365,071	254,615	72,536,435	.....	1,614,055,119	62,436,359
1877-1881..	218,507	407,656	1,850,106	62,614,706	.....	1,760,508,290	67,583,083
1882-1886..	.....	391,946	2,834,736	99,870,675	.....	2,458,490,409	74,781,418
1887-1891..	758,352	475,299	3,878,580	156,858,635	40,274	3,003,283,854	81,275,049
1892-1896..	773,692	528,785	1,804,649	160,807,652	50,129	3,827,799,481	92,782,175
1897-1901..	909,249	567,681	495,150	165,231,669	70,297	3,916,433,945	86,809,270
1902-1906..	1,783,425	537,576	2,662,121	150,913,684	96,832	3,721,782,404	98,677,584
1907-1911..	3,897,224	489,513	1,907,405	215,892,467	102,440	3,997,156,461	96,742,977
1901.....	983,059	583,208	371,911	117,199,710	70,076	3,975,005,840	89,806,453
1902.....	1,339,097	534,189	7,656,162	157,658,894	89,583	3,031,915,875	75,579,125
1903.....	1,494,132	516,570	358,505	169,656,284	87,025	4,216,108,106	108,574,905
1904.....	1,713,590	573,055	3,166,581	154,221,772	109,214	3,700,623,613	112,905,541
1905.....	1,923,174	584,680	181,199	106,483,515	100,301	3,680,932,998	102,706,599
1906.....	2,447,131	469,387	1,948,160	166,547,957	98,037	3,979,331,430	93,621,750
1907.....	3,449,517	565,252	176,917	209,603,180	99,061	4,391,839,975	86,368,490
1908.....	3,799,112	285,845	403,952	212,783,392	103,994	3,371,997,112	94,149,564
1909.....	4,129,454	517,388	8,383,966	222,900,422	91,451	4,189,421,018	114,916,520
1910.....	3,702,210	449,239	353,208	225,400,545	99,966	4,094,545,936	85,626,370

TABLE 273.—Imports of selected agricultural products, 1852-1919—Continued.

Year ending June 30—	Olive oil, for table use.	Opium, crude.	Potatoes.	Rice, and rice flour, rice meal, and broken rice.	Sisal grass.	Sugar, raw and refined.	Tea.
	<i>Gallons.</i>	<i>Pounds.</i>	<i>Bushels.</i>	<i>Pounds.</i>	<i>Long tons.</i>	<i>Pounds.</i>	<i>Pounds.</i>
1911.....	4,405,827	629,842	218,984	208,774,795	117,727	3,937,978,265	102,563,942
1912.....	4,836,515	399,837	13,734,695	190,063,331	114,467	4,104,618,393	101,406,816
1913.....	5,221,001	508,433	327,230	222,103,547	153,869	4,740,041,488	91,812,800
1914.....	6,217,560	455,200	3,645,993	300,194,917	215,547	5,066,821,873	91,130,815
1915.....	6,710,967	484,027	270,942	277,191,472	185,764	5,420,981,867	96,987,942
1916.....	7,224,431	146,658	209,532	264,324,005	228,610	5,633,161,749	109,865,935
1917.....	7,533,149	86,812	3,079,025	216,048,858	143,407	5,332,745,854	103,364,410
1918.....	2,537,512	157,834	1,180,480	456,058,608	150,164	4,903,327,249	151,314,932
1919 (prel.) ..	4,238,136	345,514	3,534,076	363,726,263	153,455	5,836,047,722	108,172,102
Year ending June 30—	Beeswax.	Onions.	Plums and prunes.	Raisins.	Currants.	Dates.	Figs.
	<i>Pounds.</i>	<i>Bushels.</i>	<i>Pounds.</i>	<i>Pounds.</i>	<i>Pounds.</i>	<i>Pounds.</i>	<i>Pounds.</i>
Average:							
1887-1891 ..	128,790	.....	60,237,642	38,545,635	.....	.....	9,783,650
1892-1896 ..	279,839	.....	12,405,549	17,745,925	34,397,754	14,914,349	10,117,049
1897-1901 ..	265,143	628,358	560,762	7,669,593	27,520,440	15,653,642	8,919,921
1902-1906 ..	456,727	924,418	563,900	7,344,676	35,457,213	25,649,432	14,334,760
1907-1911 ..	845,720	1,103,034	.....	5,283,145	35,258,628	26,059,353	19,848,037
1901.....	213,773	774,042	745,974	3,860,836	16,049,198	20,013,681	9,933,871
1902.....	408,706	796,316	522,478	6,683,545	36,238,976	21,681,159	11,087,131
1903.....	488,576	925,599	633,819	6,715,675	33,878,209	43,814,917	16,482,142
1904.....	425,168	1,171,242	494,105	6,867,617	38,347,649	21,058,164	13,178,061
1905.....	373,569	856,366	671,604	4,041,689	31,742,919	19,257,250	13,364,107
1906.....	587,617	872,566	497,494	12,414,855	37,078,311	22,435,672	17,562,358
1907.....	917,088	1,126,114	323,377	3,967,151	38,392,779	31,270,899	24,346,173
1908.....	671,526	1,275,333	335,089	9,132,353	38,652,656	24,058,343	18,836,574
1909.....	764,937	574,530	296,123	5,794,320	32,482,111	21,869,218	15,235,513
1910.....	972,145	1,024,226	.....	5,042,683	33,326,030	22,693,713	17,362,197
1911.....	902,904	1,514,967	.....	2,479,220	33,439,565	29,504,592	23,459,728
1912.....	1,076,741	1,436,037	.....	3,255,861	33,151,396	25,208,248	18,765,408
1913.....	828,793	789,458	.....	2,579,705	30,843,735	34,304,951	16,837,819
1914.....	1,412,200	1,114,811	.....	4,554,549	32,033,177	34,073,608	19,284,868
1915.....	1,564,506	829,177	.....	2,808,806	30,350,527	24,949,374	20,779,730
1916.....	2,146,380	815,872	.....	1,024,296	25,373,029	31,075,424	7,153,250
1917.....	2,685,982	1,757,948	.....	1,850,219	10,476,534	25,485,361	16,479,733
1918.....	1,826,618	1,313,402	.....	843,533	5,168,070	5,572,908	10,473,239
1919 (prel.) ..	2,126,942	152,323	.....	119,969	841,721	20,192,160	9,239,070
Year ending June 30—	Hides and skins, other than furs.			Macaroni, vermicelli, and all similar preparations.	Lemons.	Oranges.	Walnuts.
	Cattle.	Goat.	Other than cattle and goat.				
	<i>Pounds.</i>	<i>Pounds.</i>	<i>Pounds.</i>	<i>Pounds.</i>	<i>Pounds.</i>	<i>Pounds.</i>	<i>Pounds.</i>
Average:							
1897-1901 ..	.....	68,052,973	91,173,311	.....	.....	.....	.....
1902-1906 ..	126,995,011	93,674,819	115,952,418	.....	153,160,863	41,104,544	.....
1907-1911 ..	178,681,537	94,329,840	143,351,321	99,724,072	153,343,434	12,343,790	30,980,661
1901.....	129,174,624	73,745,596	77,989,617	.....	148,514,614	50,332,914	.....
1902.....	148,627,907	88,038,516	89,457,680	.....	164,075,309	52,742,476	.....
1903.....	131,644,325	85,114,070	102,340,303	28,787,821	152,004,213	56,872,070	12,362,567
1904.....	85,370,168	86,338,547	103,024,752	40,224,202	171,923,221	35,893,260	23,670,761
1905.....	113,177,357	97,803,571	126,893,934	53,441,080	139,084,321	28,880,575	21,084,104
1906.....	156,155,300	111,097,391	158,045,419	77,926,029	138,717,252	31,134,341	24,917,028
1907.....	134,671,020	101,201,596	135,111,199	87,720,730	157,859,906	21,267,346	32,597,592
1908.....	98,353,249	63,640,758	120,770,918	97,233,708	178,490,003	18,397,429	28,887,110
1909.....	192,252,083	104,048,244	148,253,998	85,114,003	135,183,550	8,435,873	26,157,703
1910.....	318,003,538	115,844,758	174,770,732	113,772,801	160,214,785	4,676,118	33,641,466
1911.....	150,127,796	86,913,842	137,849,757	114,779,116	134,968,924	7,672,186	33,619,434
1912.....	251,012,513	95,340,703	191,414,882	108,231,028	145,639,396	7,628,662	37,213,674
1913.....	268,042,390	96,250,305	207,903,995	106,500,752	151,416,412	12,252,960	26,662,441
1914.....	279,963,488	84,759,428	196,347,770	126,128,621	.....	.....	37,195,728
1915.....	334,341,417	66,547,163	137,439,153	56,542,480	.....	.....	33,445,838
1916.....	434,177,771	100,657,021	208,835,068	21,789,602	.....	.....	36,858,934
1917.....	386,600,028	105,640,307	207,967,162	3,472,503	.....	.....	38,725,362
1918.....	267,499,770	66,932,937	98,083,986	669,524	.....	.....	23,289,170
1919 (prel.) ..	253,876,730	89,004,528	105,260,468	591,804	.....	.....	10,936,630

TABLE 274.—Foreign trade of the United States in forest products, 1852-1919.

[Compiled from reports of Foreign Commerce and Navigation of the United States. All values are gold.]

Year ending June 30—	Exports.		Imports.	Excess of exports (+) or of imports (-).
	Domestic.	Foreign.		
Average:				
1852-1856.....	\$6,819,079	\$694,037	\$3,256,302	+ \$4,256,814
1857-1861.....	9,994,808	962,142	6,942,211	+ 4,014,739
1862-1866.....	7,366,103	798,076	8,511,370	- 347,191
1867-1871.....	11,775,297	690,748	14,812,576	- 2,346,531
1872-1876.....	17,906,771	959,862	19,728,458	- 861,825
1877-1881.....	17,579,313	552,514	22,006,227	- 3,874,400
1882-1886.....	24,704,992	1,417,226	34,252,753	- 8,130,535
1887-1891.....	26,060,729	1,442,760	39,647,287	- 12,143,798
1892-1896.....	29,276,428	1,707,307	45,091,081	- 14,107,346
1897-1901.....	45,960,863	3,283,274	52,326,879	- 3,082,742
1902-1906.....	63,584,670	3,850,221	79,885,457	- 12,450,566
1907-1911.....	88,764,471	6,488,455	137,051,471	- 41,798,545
1901.....	55,369,161	3,599,192	57,143,650	+ 1,824,703
1902.....	48,928,764	3,609,071	59,187,049	- 6,649,214
1903.....	58,734,016	2,865,325	71,478,022	- 9,878,681
1904.....	70,085,789	4,177,352	79,619,296	- 5,356,155
1905.....	63,199,348	3,790,097	92,680,555	- 25,691,110
1906.....	76,975,431	4,809,261	96,462,364	- 14,677,672
1907.....	92,948,705	5,500,331	122,420,776	- 23,971,740
1908.....	90,362,073	4,570,397	97,733,092	- 2,800,622
1909.....	72,442,454	4,982,810	123,920,126	- 46,494,862
1910.....	85,030,230	9,801,881	178,871,797	- 84,039,686
1911.....	103,038,892	7,586,854	162,311,565	- 51,685,819
1912.....	108,122,254	6,413,343	172,523,465	- 57,987,868
1913.....	124,835,784	7,431,851	180,502,444	- 48,234,809
1914.....	106,978,554	4,517,766	155,261,300	- 43,764,980
1915.....	52,553,536	5,089,299	165,849,493	-108,206,658
1916.....	68,155,479	4,364,335	252,851,305	-180,331,491
1917.....	68,918,836	11,171,520	322,699,430	-242,609,074
1918.....	87,180,768	6,066,140	335,033,459	-241,786,551
1919 (preliminary).....	107,052,372	5,562,309	284,684,442	-172,069,761

TABLE 275.—Exports of selected domestic forest products, 1852-1919.

[Compiled from reports of Foreign Commerce and Navigation of the United States. Where figures are lacking, either there were no exports or they were not separately classified for publication.]

Year ending June 30—	Lumber.			Rosin.	Spirits of turpentine.	Timber.	
	Boards, deals, and planks. <sup>1</sup>	Shooks, other than box.	Staves.			Hewn.	Sawed.
	<i>M feet.</i>	<i>Number.</i>	<i>Number.</i>	<i>Barrels.</i>	<i>Gallons.</i>	<i>Cubic feet.</i>	<i>M feet.</i>
Average:							
1851-1856.....	129,499	.....	.....	552,210	1,369,250	.....	.....
1857-1861.....	205,476	.....	.....	664,206	2,735,104	.....	.....
1862-1866.....	138,020	.....	.....	69,314	102,162	.....	.....
1867-1871.....	138,720	.....	.....	491,774	2,693,412	.....	.....
1872-1876.....	221,658	.....	.....	845,803	.....	17,459,632	.....
1877-1881.....	303,114	.....	.....	.....	7,138,556	18,316,876	.....
1882-1886.....	433,963	.....	.....	1,289,869	9,301,894	13,701,663	.....
1887-1891.....	531,755	593,054	.....	1,533,834	10,794,025	6,401,543	218,796
1892-1896.....	66,090	435,581	.....	2,006,427	14,258,928	6,062,418	263,641
1897-1901.....	957,218	668,797	.....	2,477,696	18,349,386	5,146,927	428,755
1902-1906.....	212,476	765,215	5,1234,056	2,453,280	16,927,090	3,968,469	508,212
1907-1911.....	1,649,203	925,828	5,6181,900	2,355,560	16,658,955	3,406,245	479,776
1901.....	1,101,815	714,651	47,363,262	2,820,815	20,240,851	4,642,698	533,920
1902.....	942,814	788,241	46,998,512	2,535,962	19,177,788	5,388,439	412,750
1903.....	1,065,771	566,205	55,879,010	2,396,498	16,378,787	3,291,498	530,659
1904.....	1,426,784	533,182	47,420,095	2,585,108	17,202,808	3,788,740	558,690
1905.....	1,283,406	872,192	48,286,285	2,310,275	15,894,813	3,856,623	486,411
1906.....	1,343,607	1,066,253	57,586,378	2,438,556	15,981,253	3,517,046	552,548
1907.....	1,623,964	803,346	51,120,171	2,560,966	15,854,676	3,278,110	600,865
1908.....	1,548,130	900,812	61,696,949	2,712,732	19,532,583	4,883,506	463,440
1909.....	1,357,822	977,376	52,583,016	2,170,177	17,502,028	2,950,528	383,309
1910.....	1,684,489	928,197	49,783,771	2,144,318	15,587,737	3,245,196	451,721
1911.....	2,031,608	1,019,411	65,725,595	2,189,607	14,817,751	2,673,887	499,547
1912.....	2,306,680	1,161,591	64,162,599	2,474,460	19,599,241	<i>M feet.</i>	406,954
1913.....	2,550,308	1,710,095	89,005,624	2,806,046	21,093,597	31,067	477,135
1914.....	2,405,296	867,805	77,150,535	2,417,950	18,900,704	34,502	411,307
1915.....	1,129,205	620,043	39,297,268	1,372,316	9,464,120	29,859	167,671
1916.....	1,177,331	611,556	57,537,610	1,571,279	9,310,268	6,118	191,577
1917.....	1,041,845	1,079,510	61,469,225	1,638,590	8,841,875	9,628	177,072
1918.....	1,067,709	1,758,667	63,207,351	1,070,929	5,095,124	7,293	98,791
1919 (preliminary).....	1,077,973	3,027,701	62,538,922	881,777	8,063,578	7,426	86,770
						5,021	

<sup>1</sup> Including "Joists and scantling" prior to 1884.

TABLE 276.—Imports of selected forest products, 1852-1919.

Year ending June 30—	Camphor, crude.	India rubber.	Rubber gums, total.	Lumber.		Shellac.	Wood pulp.
				Boards, deals, planks, and other sawed.	Shingles.		
Average:	<i>Pounds.</i>	<i>Pounds.</i>	<i>Pounds.</i>	<i>M feet.</i>	<i>M.</i>	<i>Pounds.</i>	<i>Long tons.</i>
1852-1856.....	213,720	.....	.....	.....	.....	.....	.....
1857-1861.....	360,522	.....	.....	.....	.....	.....	.....
1862-1866.....	386,731	.....	.....	.....	.....	634,276	.....
1867-1871.....	.....	.....	<sup>1</sup> 7,389,980	.....	.....	.....	.....
1872-1876.....	.....	.....	12,631,388	564,642	88,197	.....	.....
1877-1881.....	1,515,614	.....	15,610,634	417,907	55,394	.....	.....
1882-1886.....	1,958,608	.....	24,480,997	577,728	87,760	.....	.....
1887-1891.....	2,273,883	.....	33,226,520	646,745	184,050	5,086,421	37,251
1892-1896.....	1,491,902	38,359,547	39,671,553	661,495	.....	5,848,339	42,771
1897-1901.....	1,858,018	47,469,136	52,974,744	566,394	.....	8,839,232	46,827
1902-1906.....	2,139,183	57,903,641	75,908,633	727,205	772,340	11,613,967	120,764
1907-1911.....	2,939,167	80,129,567	121,504,098	899,659	866,565	19,046,030	319,007
1901.....	2,175,784	55,275,529	64,927,176	490,820	555,853	9,608,745	46,757
1902.....	1,831,058	50,413,481	67,790,069	665,603	707,614	9,064,789	67,416
1903.....	2,472,440	55,010,571	69,311,678	720,937	724,131	11,590,725	116,881
1904.....	2,819,673	59,015,551	74,327,584	589,232	770,373	10,933,413	144,796
1905.....	1,904,002	67,234,256	87,004,384	710,538	758,725	10,700,817	167,504
1906.....	1,668,744	<sup>1</sup> 57,844,345	81,109,451	949,717	900,856	15,780,090	157,224
1907.....	3,138,070	<sup>1</sup> 76,963,838	106,747,589	934,195	881,003	17,785,960	213,110
1908.....	2,814,299	<sup>1</sup> 62,233,160	85,809,625	791,288	988,081	13,361,932	237,514
1909.....	1,996,499	<sup>1</sup> 88,359,895	114,598,768	846,024	1,058,363	19,185,137	274,217
1910.....	3,006,648	<sup>1</sup> 101,044,681	154,620,629	1,054,416	762,798	29,402,182	378,322
1911.....	3,726,319	72,046,260	145,743,880	872,374	642,582	15,494,940	491,873
1912.....	2,154,646	110,210,173	175,965,538	905,275	514,657	18,745,771	477,508
1913.....	3,709,264	113,384,359	170,747,339	1,090,628	560,297	21,912,015	502,913
1914.....	3,476,908	131,995,742	161,777,250	928,873	895,038	16,719,756	508,360
1915.....	3,729,207	172,068,428	196,121,979	939,322	1,487,116	24,153,363	587,922
1916.....	4,574,430	267,775,557	304,182,814	1,218,068	1,769,333	25,817,509	507,048
1917.....	6,884,950	333,373,711	364,913,711	1,175,319	1,924,139	32,539,522	699,475
1918.....	3,638,384	389,599,015	414,983,610	1,282,701	1,878,465	22,913,256	504,152
1919 (prelimi- nary).....	2,622,792	402,471,531	422,215,004	980,010	1,757,170	14,268,653	165,031

<sup>1</sup> Includes "Gutta-percha" only, for 1867.

TABLE 277.—Principal farm products imported from specified countries into the United States, 1917-1919.

Country of origin and article.	Year ending June 30—					
	1917		1918		1919	
	Quantity.	Value.	Quantity.	Value.	Quantity.	Value.
Brazil:						
Cocoa (crude)....pounds..	51,461,624	\$4,959,064	91,351,529	\$8,383,383	52,038,036	\$5,182,614
Coffee.....do.....	907,197,562	85,761,395	743,958,456	60,890,926	571,921,573	76,425,701
British West Indies:						
Bananas.....bunches..	2,191,516	677,129	2,064,274	727,747	5,441,461	1,886,894
Cocoa.....pounds..	60,139,918	7,323,005	51,438,970	6,295,562	21,625,543	3,715,014
Canada: Tea.....do.....	3,160,459	1,084,134	1,914,169	647,712	2,375,497	851,244
China: Tea.....do.....	19,810,428	3,109,912	21,082,866	4,361,557	10,322,467	2,475,221
Colombia: Coffee.....do.....	150,591,659	17,971,874	112,159,390	13,108,462	121,416,418	18,644,355
Cuba:						
Bananas.....bunches..	2,184,110	837,251	1,151,165	482,046	1,267,440	506,253
Sugar (raw).....pounds..	4,669,097,398	204,521,160	4,560,749,643	219,461,319	5,488,711,032	290,732,477
Dominican Republic: Cocoa, .....pounds..	61,443,869	7,202,747	39,851,184	3,660,091	39,406,460	5,014,098
Ecuador: Cocoa.....do.....	67,227,698	8,178,778	76,786,657	7,975,868	57,123,389	6,362,240
France:						
Cheese.....do.....	1,937,341	754,012	1,026,117	528,926	452,452	394,337
Olive oil (salad) . .gallons..	726,771	1,211,731	227,617	576,602	60,533	214,650
Italy:						
Cheese.....pounds..	8,482,280	2,545,286	16,044	7,883	57	23
Macaroni.....do.....	2,431,910	191,845	484	40	.....	.....
Olive oil (salad) . .gallons..	2,882,535	4,770,315	200,403	467,692	628	920
Japan: Tea.....pounds..	52,418,963	8,825,089	52,996,471	9,511,283	57,600,251	13,420,067
Mexico: Coffee.....do.....	54,908,223	6,382,845	31,118,513	3,336,131	21,963,490	3,417,612
Netherlands:						
Cheese.....do.....	249,371	68,645	.....	.....	.....	.....
Coffee.....do.....	150,000	18,090	.....	.....	.....	.....
Philippine Islands: Sugar, .....pounds..	267,891,954	8,382,562	173,600,941	7,913,247	210,950,670	9,359,192
Portugal: Cocoa.....do.....	16,551,624	2,148,191	134,904	20,912	.....	.....
Spain:						
Olive oil (salad) . .gallons..	3,776,581	4,350,747	2,091,400	2,783,691	4,203,827	7,735,703
Goat skins.....pounds..	1,869,360	1,621,021	806,152	845,714	884,480	1,090,668
Switzerland: Cheese..do.....	1,640,656	341,063	.....	.....	.....	.....
United Kingdom:						
Cocoa.....do.....	11,650,811	1,460,314	1,038,142	113,304	695,082	84,703
Tea.....do.....	13,857,721	3,309,507	487,063	248,678	13,738	4,754

TABLE 278.—Principal farm products exported to specified countries from the United States, 1917-1919.

Country to which consigned, and article.	Year ending June 30—					
	1917		1918		1919	
	Quantity.	Value.	Quantity.	Value.	Quantity.	Value.
Belgium:						
Corn.....bushels..	581,371	\$590,771	3,714,233	\$7,277,381	1,567,631	\$2,358,829
Wheat.....do.....	2,698,044	4,887,416	6,007,986	13,674,261	25,972,439	63,244,189
Bacon.....pounds..	65,219,598	8,508,658	68,670,327	17,200,008	109,590,712	33,041,028
Hams and shoulders..do....					32,583,389	9,350,246
Lard.....do.....	96,761,185	13,815,450	116,154,490	28,105,585	190,769,671	55,465,477
Brazil: Wheat flour...barrels..	301,614	2,743,818	101,927	1,149,284	31,639	373,956
Canada:						
Corn.....bushels..	15,724,838	16,158,665	7,895,892	13,127,564	8,939,735	12,678,373
Wheat.....do.....	4,714,836	9,856,529	252,540	577,965	26,484,027	61,442,170
Wheat flour.....barrels..	77,115	580,326	83,334	884,042	193,025	2,093,737
Bacon.....pounds..	118,709,847	21,366,115	42,837,136	11,744,199	26,186,013	8,289,205
Hams and shoulders..do....	5,617,090	1,021,892	14,286,628	3,787,253	6,973,844	2,035,163
Lard.....do.....	5,375,768	984,930	893,977	208,131	3,565,054	1,030,982
Pork, pickled.....do....	16,929,411	2,501,890	13,689,396	3,065,724	8,186,862	1,906,645
China: Wheat flour...barrels..	9,806	44,532	275	2,791		
Cuba:						
Corn.....bushels..	2,819,278	2,948,100	1,142,293	2,094,937	1,453,801	2,457,377
Wheat flour.....barrels..	1,016,675	8,661,925	679,689	7,733,557	1,058,028	11,652,051
Bacon.....pounds..	14,914,902	2,533,943	20,293,559	5,521,432	9,154,147	2,511,016
Hams and shoulders..do....	9,867,826	1,880,230	9,990,141	2,669,458	7,641,206	2,446,745
Lard.....do.....	43,732,924	8,819,512	52,574,278	14,337,227	25,572,370	7,831,033
Pork, pickled.....do....	7,700,421	1,145,958	8,935,072	2,148,796	6,694,491	1,706,558
Denmark: Corn.....bushels..	7,075,254	9,205,072			333,910	601,038
France:						
Wheat.....bushels..	16,253,262	31,698,762	3,837,927	9,428,203	13,297,243	31,413,113
Bacon.....pounds..	77,035,622	12,062,410	73,531,892	19,301,977	220,390,525	62,601,176
Lard.....do.....	54,967,832	10,712,463	33,427,329	8,603,286	89,806,249	25,751,901
Hongkong: Wheat flour						
.....barrels..	61,800	306,756	1,250	13,825	1,506	15,822
Italy:						
Wheat.....bushels..	13,746,512	26,743,498	6,756,191	15,579,424	32,689,845	77,427,165
Lard.....pounds..	4,981,846	1,058,998	2,136,645	506,717	1,270	426
Japan: Wheat flour...barrels..	4,083	35,652	69	794		
Mexico:						
Corn.....bushels..	2,530,699	3,133,896	3,272,754	6,871,144	1,214,717	2,626,249
Wheat.....do.....	54,597	83,535	2,126	3,849		
Lard.....pounds..	13,261,559	2,270,025	6,957,993	1,625,892	16,630,794	4,838,200
Netherlands:						
Corn.....bushels..	7,923,706	8,237,912	246,004	456,009	100,168	167,192
Wheat.....do.....	19,127,675	37,946,031	155,550	380,224	3,904,617	9,905,251
Wheat flour.....barrels..	591,182	4,087,784	69,253	690,141	1,117,018	13,269,744
Bacon.....pounds..	10,625,101	1,501,376			22,476,538	6,985,756
Lard.....do.....	20,446,110	2,838,460			17,683,052	5,623,665
Lard, neutral.....do....	2,657,914	432,566			5,490,968	1,795,071
Oleo oil.....do.....	8,081,795	1,201,373			29,694	8,411
Norway: Oleo oil.....do....	15,907,144	2,745,117	774,004	175,106	3,353,719	951,300
Philippine Islands: Wheat						
flour.....barrels..	76,089	420,480	549	5,442	6,039	65,403
United Kingdom:						
Corn.....bushels..	24,493,817	27,860,538	21,197,784	39,118,255	2,522,397	4,754,427
Wheat.....do.....	67,976,120	139,429,196	15,129,803	36,470,014	66,147,422	156,153,006
Wheat flour.....barrels..	3,015,525	21,947,731	10,055,827	112,664,938	10,745,508	119,094,414
Bacon.....pounds..	346,758,407	65,192,174	533,135,385	147,983,735	658,341,849	207,507,365
Hams and shoulders..do....	217,434,561	40,800,138	372,722,508	95,792,492	416,227,806	128,077,781
Lard.....do.....	178,110,633	32,816,184	159,959,165	38,855,685	287,257,312	79,607,649
Oleo oil.....do.....	31,761,124	5,316,644	48,244,317	10,184,472	27,919,586	7,048,370
Pork, pickled.....do....	6,058,672	929,881	1,903,144	447,141	2,981,272	880,493

TABLE 279.—Shipments of principal domestic farm and forest products from the United States to Hawaii and Porto Rico, 1917-1919.

[These shipments are not included in the domestic exports from or imports into the United States.]

Possession and article.	Year ending June 30—					
	1917		1918		1919	
	Quantity.	Value.	Quantity.	Value.	Quantity.	Value.
HAWAII.						
Dairy products.....pounds..	5,537,968	\$878,816	4,057,847	\$878,447	3,837,032	\$980,732
Meat products.....		1,165,817		740,107		910,320
Grain and grain products.....		3,142,022		3,039,729		3,056,998
Rice.....pounds..	5,918,689	267,423	8,651,147	594,698	9,918,602	717,228
Lumber.....		1,638,887		1,494,241		2,294,309
PORTO RICO.						
Dairy products.....pounds..	4,346,394	652,888	5,692,110	1,062,646	6,582,822	1,215,430
Meat products.....		4,311,385		5,011,966		4,786,947
Beans and dried peas.bushels..	211,542	964,072	218,608	1,259,334	205,724	1,051,289
Grain and grain products.....		4,086,369		4,310,180		5,221,972
Rice.....pounds..	154,806,589	6,587,122	125,131,832	9,144,940	155,069,940	11,668,992
Sugar.....do.....	9,331,896	670,530	3,017,215	245,074	276,172	24,450
Tobacco.....do.....	2,376,479	432,453	2,003,224	637,872		
Lumber.....		1,294,561		1,074,992		914,247

TABLE 280.—Shipments of principal domestic farm products from Hawaii and Porto Rico to the United States, 1917-1919.

Possession and article.	Year ending June 30—					
	1917		1918		1919	
	Quantity.	Value.	Quantity.	Value.	Quantity.	Value.
HAWAII.						
Coffee.....pounds..	1,987,035	\$297,972	1,968,080	\$275,733	5,623,145	\$925,104
Pineapples, canned.....		7,970,522		8,394,307		11,989,611
Sugar.....pounds..	1,162,605,056	62,741,164	1,080,908,797	64,108,540	1,215,594,766	75,511,738
PORTO RICO.						
Grapefruit.....boxes..	435,890	939,677	549,825	1,120,330	367,369	739,106
Oranges.....do.....	502,313	1,008,465	602,987	1,230,984	373,679	769,226
Pineapples.....		916,415		617,496		458,675
Molasses and sirup.....gallons..	18,751,212	1,332,538	14,495,752	1,213,382	15,118,678	1,507,101
Sugar.....pounds..	977,377,996	53,987,767	672,937,334	41,310,845	703,286,023	48,091,799
Tobacco, leaf.....do.....	7,958,439	3,583,052	13,124,315	7,913,675	12,460,316	7,259,709

TABLE 281.—Destination of principal farm products exported from the United States, 1910-1919.

Article, and country to which consigned.	Quantity.				Per cent of total.			
	Year ending June 30—							
	Average, 1910-1914.	1917	1918	1919 (prel.)	Average, 1910-1914.	1917	1918	1919 (prel.)
<b>ANIMAL MATTER.</b>								
<b>Cattle:</b>	<i>Number.</i>	<i>Number.</i>	<i>Number.</i>	<i>Number.</i>				
Canada.....	9,105	6,382	7,286	.....	10.4	47.7	40.0	.....
Mexico.....	7,341	4,324	7,777	.....	8.4	32.3	42.7	.....
United Kingdom.....	66,422	.....	19	.....	75.8	.....	.1	.....
Other countries.....	4,757	2,681	3,131	.....	5.4	20.0	17.2	.....
Total.....	87,625	13,387	18,213	42,345	100.0	100.0	100.0	100.0
<b>Horses:</b>								
Canada.....	24,486	28,546	18,064	9,684	87.2	10.2	21.3	34.6
Cuba.....	1,212	1,000	4,468	1,538	4.3	.4	5.3	5.5
Mexico.....	1,197	2,659	4,775	2,028	4.3	1.0	5.6	7.2
United Kingdom.....	522	100,110	56,215	12,973	1.9	35.9	66.3	46.4
Other countries.....	656	146,359	1,243	1,752	2.3	52.5	1.5	6.3
Total.....	28,073	278,674	84,765	27,975	100.0	100.0	100.0	100.0
<b>Butter:</b>	<i>Pounds.</i>	<i>Pounds.</i>	<i>Pounds.</i>	<i>Pounds.</i>				
Canada.....	499,942	1,323,653	44,749	40,693	11.7	4.9	.3	.1
Central American States and British Honduras.....	694,345	814,396	633,753	439,950	16.2	3.0	3.6	1.3
Mexico.....	369,271	558,369	223,091	430,156	8.6	2.1	1.3	1.3
United Kingdom.....	601,095	20,839,583	13,982,559	26,530,106	14.1	77.7	78.8	78.6
Venezuela.....	599,600	79,785	6,402	664,419	14.0	.3	( <sup>1</sup> )	2.0
West Indies and Bermuda.....	1,361,406	1,829,040	1,380,404	1,846,358	31.8	6.8	7.8	5.5
Other countries.....	152,296	1,390,266	1,465,008	3,788,278	3.6	5.2	8.2	11.2
Total.....	4,277,955	26,835,092	17,735,966	33,739,960	100.0	100.0	100.0	100.0
<b>Meat products:</b>								
<b>Beef products—</b>								
<b>Beef, canned—</b>								
United Kingdom..	5,129,188	40,218,190	46,375,149	25,318,966	54.6	59.6	47.6	23.3
Other countries...	4,262,934	27,317,935	50,968,134	83,170,506	45.4	40.4	52.4	76.7
Total.....	9,392,122	67,536,125	97,343,283	108,489,472	100.0	100.0	100.0	100.0
<b>Beef, fresh—</b>								
Panama.....	5,026,662	235,034	144,442	257,400	17.1	.1	( <sup>1</sup> )	.1
United Kingdom....	23,410,437	125,687,523	285,789,315	272,128,738	79.5	63.7	77.2	81.9
Other countries.....	1,015,203	71,254,544	84,099,143	59,819,038	3.4	36.2	22.8	18.0
Total.....	29,452,302	197,177,101	370,032,900	332,205,176	100.0	100.0	100.0	100.0
<b>Beef, pickled and other cured—</b>								
Canada.....	1,386,090	9,394,712	2,623,317	1,603,519	4.2	16.2	4.8	3.6
Germany.....	3,617,862	.....	.....	.....	11.0	.....	.....	.....
Newfoundland and Labrador.....	4,941,896	6,802,524	5,505,008	4,250,721	15.1	11.7	10.1	9.4
United Kingdom....	7,902,166	7,489,665	4,205,294	3,995,416	24.1	12.9	7.7	8.9
West Indies and Bermuda.....	4,548,476	1,868,094	2,245,472	1,093,359	13.9	3.2	4.1	2.4
Other countries.....	10,413,273	32,498,672	39,888,819	34,124,846	31.7	56.0	73.3	75.7
Total.....	32,809,763	58,053,667	54,467,910	45,067,861	100.0	100.0	100.0	100.0
<b>Oleo oil <sup>2</sup>—</b>								
Denmark.....	5,714,442	2,764,095	30,000	5,441,183	5.0	4.1	.1	9.2
Germany.....	20,068,668	.....	.....	.....	17.6	.....	.....	.....
Netherlands.....	57,084,122	8,081,795	.....	29,694	50.2	12.0	.....	.1
Norway.....	8,335,573	15,907,144	774,004	3,353,719	7.3	23.7	1.4	5.7
Sweden.....	2,350,272	2,247,553	13,313	3,859,970	2.1	3.3	( <sup>1</sup> )	6.5
Turkey in Europe...	3,869,784	.....	.....	.....	3.4	.....	.....	.....
United Kingdom....	9,117,005	31,761,124	48,244,317	27,919,586	8.0	47.3	85.2	47.2
Other countries.....	7,217,847	6,348,400	7,541,754	18,488,170	6.4	9.6	13.3	31.3
Total.....	113,757,713	67,110,111	56,603,388	59,092,322	100.0	100.0	100.0	100.0

<sup>1</sup> Less than 0.05 of 1 per cent.<sup>2</sup> For "Oleo oil" the average is for 4 years, 1911-1914.



TABLE 281.—Destination of principal farm products exported from the United States, 1910-1919—Continued.

Article, and country to which consigned.	Quantity.				Per cent of total.			
	Year ending June 30—							
	Average, 1910-1914.	1917	1918	1919 (prel.)	Average, 1910-1914.	1917	1918	1919 (prel.)
<b>ANIMAL MATTER—CON.</b>								
Beef, fresh—Con.								
Lard compounds—	<i>Pounds.</i>	<i>Pounds.</i>	<i>Pounds.</i>	<i>Pounds.</i>				
Cuba.....	19,793,565	14,164,676	7,735,338	7,377,716	29.4	25.1	24.7	5.6
Mexico.....	5,399,201	6,863,487	4,441,734	7,318,879	8.0	12.2	14.2	5.6
United Kingdom....	20,830,150	13,507,936	4,416,476	58,676,804	30.9	24.0	14.1	44.5
Other countries.....	21,295,941	21,823,394	14,684,834	58,377,104	31.7	38.7	47.0	44.3
Total.....	67,318,857	56,359,493	31,278,382	131,750,503	100.0	100.0	100.0	100.0
Pork products—								
Bacon—								
Belgium.....	4,901,373	65,219,598	68,670,327	109,590,712	2.7	9.8	8.4	8.8
Canada.....	4,964,662	118,709,847	42,837,136	26,186,013	2.7	17.8	5.3	2.1
Cuba.....	7,696,815	14,914,902	20,293,559	9,154,147	4.2	2.2	2.5	.7
France.....	2,689,203	77,035,622	73,531,892	220,390,525	1.5	11.5	9.0	17.8
Italy.....	7,560,557	19,378,346	74,459,980	80,552,049	4.1	2.9	9.1	6.5
Netherlands.....	4,408,989	10,625,101	.....	22,476,538	2.4	1.6	.....	1.8
Norway.....	3,637,518	8,296,500	25,243	18,182,066	2.0	1.2	(1)	1.5
Sweden.....	1,909,280	1,065,440	48	33,460,542	1.0	.2	(1)	2.7
United Kingdom..	133,760,286	346,758,407	533,135,385	658,341,849	73.3	52.0	65.4	53.1
Other countries...	10,945,409	5,148,209	2,340,854	61,206,532	6.1	.8	.3	5.0
Total.....	182,474,092	667,151,972	815,294,424	1,239,540,973	100.0	100.0	100.0	100.0
Hams and shoulders, cured—								
Belgium.....	7,863,470	.....	.....	32,583,389	4.7	.....	.....	4.9
Canada.....	4,509,867	5,617,090	14,286,628	6,973,844	2.7	2.1	3.4	1.0
Cuba.....	4,696,184	9,867,826	9,990,141	7,641,206	2.8	3.7	2.4	1.1
United Kingdom..	143,087,022	217,434,561	372,722,508	416,227,806	85.8	81.5	88.8	62.3
Other countries...	6,656,591	33,737,104	22,572,592	204,421,774	4.0	12.7	5.4	30.7
Total.....	166,813,134	266,656,581	419,571,869	667,848,019	100.0	100.0	100.0	100.0
Lard—								
Belgium.....	17,076,171	96,761,185	116,154,490	190,769,671	3.6	21.8	29.6	26.3
Canada.....	10,181,941	5,375,768	893,977	3,565,054	2.1	1.2	.2	.5
Cuba.....	41,378,503	48,732,924	52,574,278	25,572,370	8.7	11.0	13.4	3.5
Denmark.....	2,480,647	841,110	75,000	22,255,753	.5	.2	(1)	3.1
Ecuador.....	3,369,460	3,842,692	1,810,527	1,307,588	.7	.9	.5	.2
France.....	12,089,618	54,967,832	33,427,329	89,806,249	2.5	12.4	8.5	12.4
Germany.....	142,311,431	.....	.....	.....	30.0	.....	.....	.....
Italy.....	4,655,944	4,981,846	2,136,645	1,270	1.0	1.1	.5	(1)
Mexico.....	7,000,932	13,261,559	6,957,993	16,630,794	1.5	3.0	1.8	2.3
Netherlands.....	36,501,329	20,446,110	.....	17,683,052	7.7	4.6	.....	2.4
Peru.....	2,784,573	2,082,555	1,400,455	561,815	.6	.5	.4	.8
United Kingdom..	169,176,230	178,110,633	159,959,165	287,257,312	35.7	40.0	40.8	39.6
Other countries...	25,348,135	15,365,326	17,116,496	70,166,940	5.4	3.3	4.3	8.9
Total.....	474,354,914	444,769,540	392,506,355	725,577,868	100.0	100.0	100.0	100.0
Lard, neutral <sup>2</sup> —								
Denmark.....	2,250,893	1,022,499	.....	4,026,247	5.2	5.8	.....	23.1
Germany.....	9,228,140	.....	.....	.....	21.2	.....	.....	.....
Netherlands.....	25,078,158	2,657,914	.....	5,490,968	57.6	15.1	.....	31.6
Norway.....	2,679,054	3,234,094	322,932	1,072,748	6.1	18.4	7.6	6.2
United Kingdom..	1,871,448	8,627,547	3,495,665	3,092,009	4.3	49.1	82.1	17.8
Other countries...	2,463,857	2,034,186	439,932	3,713,916	5.6	11.6	10.3	21.3
Total.....	43,571,550	17,576,240	4,258,529	17,395,888	100.0	100.0	100.0	100.0
Pork, pickled—								
British Guiana....	1,539,772	1,083,300	863,280	779,550	3.2	2.3	2.6	2.5
Canada.....	10,117,759	16,929,411	13,689,396	8,186,862	21.0	36.0	41.2	26.0
Cuba.....	7,286,791	7,700,421	8,935,072	6,694,491	15.1	16.4	26.9	21.2
Haiti.....	1,818,119	772,310	481,190	.....	3.8	1.6	1.4	.....
Newfoundland and Labrador.....	5,920,365	6,262,085	3,220,600	5,705,596	12.3	13.3	9.7	18.1
Panama.....	1,426,085	618,416	276,782	105,100	3.0	1.3	.8	.3
United Kingdom..	10,225,205	6,058,672	1,903,144	2,981,272	21.2	12.9	5.7	9.5
Other countries...	9,939,933	7,568,106	3,852,038	7,051,626	20.4	16.2	11.7	22.4
Total.....	48,274,929	46,992,721	33,221,502	31,504,497	100.0	100.0	100.0	100.0

<sup>1</sup> Less than 0.05 of 1 per cent.<sup>2</sup> For "Lard, neutral," the average is for 4 years, 1911-1914.

TABLE 281.—Destination of principal farm products exported from the United States, 1910-1919—Continued.

Article, and country to which consigned.	Quantity.				Per cent of total.			
	Year ending June 30—							
	Average, 1910-1914.	1917	1918	1919 (prel.)	Average, 1910-1914.	1917	1918	1919 (prel.)
<b>VEGETABLE MATTER.</b>								
<b>Cotton:</b>	<i>Pounds.</i>	<i>Pounds.</i>	<i>Pounds.</i>	<i>Pounds.</i>				
Austria-Hungary.....	48,200,615	-----	-----	27,692,987	1.1	-----	-----	1.0
Belgium.....	91,891,387	-----	-----	36,325,977	2.1	-----	-----	1.3
Canada.....	76,708,788	93,600,456	124,986,426	101,507,722	1.7	3.0	5.4	3.7
France.....	543,310,082	527,874,622	329,276,533	382,786,580	12.3	17.1	14.2	14.0
Germany.....	1,257,474,563	-----	-----	-----	28.5	-----	-----	-----
Italy.....	250,388,023	343,578,824	184,606,646	261,139,624	5.7	11.1	8.0	9.6
Japan.....	148,287,700	265,445,968	291,772,827	404,656,654	3.4	8.6	12.6	14.8
Mexico.....	10,601,091	2,648,957	5,353,162	853,483	.2	.1	.2	(1)
Netherlands.....	12,177,934	31,080,490	5,049,224	28,974,704	.3	1.0	.2	1.1
Russia, European.....	43,788,355	24,594,286	7,972,533	155,015	1.0	.8	.3	(1)
Spain.....	134,932,086	197,046,594	129,596,749	140,671,300	3.1	6.4	5.6	5.1
Sweden.....	18,142,436	53,040,674	517,866	44,196,386	.4	1.7	(1)	1.6
United Kingdom.....	1,754,711,933	1,447,711,674	1,193,550,402	1,239,461,596	39.7	46.9	51.4	45.4
Other countries.....	29,187,164	101,458,241	47,829,297	65,261,097	.5	3.3	2.1	2.4
<b>Total.....</b>	<b>4,419,802,157</b>	<b>3,088,080,786</b>	<b>2,320,511,665</b>	<b>2,733,683,125</b>	<b>100.0</b>	<b>100.0</b>	<b>100.0</b>	<b>100.0</b>
<b>Fruits:</b>								
<b>Apples, dried—</b>								
Germany.....	17,473,832	-----	-----	-----	49.7	-----	-----	-----
Netherlands.....	9,612,942	187,286	-----	-----	27.4	1.8	-----	-----
Other countries.....	8,050,439	10,170,505	2,602,590	-----	22.9	98.2	100.0	-----
<b>Total.....</b>	<b>35,137,213</b>	<b>10,357,791</b>	<b>2,602,590</b>	<b>19,313,882</b>	<b>100.0</b>	<b>100.0</b>	<b>100.0</b>	<b>100.0</b>
<b>Apples, fresh—</b>	<i>Barrels.</i>	<i>Barrels.</i>	<i>Barrels.</i>	<i>Barrels.</i>				
Canada.....	221,431	314,955	457,948	265,065	14.3	18.1	72.1	16.8
Germany.....	157,020	-----	-----	-----	10.1	-----	-----	-----
United Kingdom.....	1,020,968	1,147,412	1,766	1,016,945	65.8	65.9	.3	64.5
Other countries.....	151,834	277,630	175,695	294,738	9.8	16.0	27.6	18.7
<b>Total.....</b>	<b>1,551,253</b>	<b>1,739,997</b>	<b>635,409</b>	<b>1,576,748</b>	<b>100.0</b>	<b>100.0</b>	<b>100.0</b>	<b>100.0</b>
<b>Apricots, dried—</b>	<i>Pounds.</i>	<i>Pounds.</i>	<i>Pounds.</i>	<i>Pounds.</i>				
Belgium.....	956,675	-----	-----	-----	4.9	-----	-----	-----
Canada.....	1,117,625	751,012	1,388,275	1,529,328	5.7	7.6	26.5	7.3
France.....	2,558,956	5,754,643	465,525	3,720,208	13.2	58.5	8.9	17.8
Germany.....	5,208,071	-----	-----	-----	26.8	-----	-----	-----
Netherlands.....	2,204,930	345,031	-----	206,230	11.3	3.5	-----	1.0
United Kingdom.....	5,552,246	614,139	787,913	4,925,910	28.6	6.2	15.1	23.5
Other countries.....	1,839,506	2,376,294	2,587,905	10,593,538	9.5	24.2	49.5	50.4
<b>Total.....</b>	<b>19,438,009</b>	<b>9,841,119</b>	<b>5,229,618</b>	<b>20,975,214</b>	<b>100.0</b>	<b>100.0</b>	<b>100.0</b>	<b>100.0</b>
<b>Oranges—</b>	<i>Boxes.</i>	<i>Boxes.</i>	<i>Boxes.</i>	<i>Boxes.</i>				
Canada.....	1,135,194	1,726,394	1,190,629	1,315,207	95.7	93.3	96.0	93.8
Other countries.....	50,988	123,978	49,848	86,973	4.3	6.7	4.0	6.2
<b>Total.....</b>	<b>1,186,182</b>	<b>1,850,372</b>	<b>1,240,477</b>	<b>1,402,180</b>	<b>100.0</b>	<b>100.0</b>	<b>100.0</b>	<b>100.0</b>
<b>Prunes—</b>	<i>Pounds.</i>	<i>Pounds.</i>	<i>Pounds.</i>	<i>Pounds.</i>				
Belgium.....	5,005,565	-----	-----	-----	6.2	-----	-----	-----
Canada.....	11,327,559	11,112,227	18,025,903	7,873,557	14.1	18.6	54.7	13.3
France.....	10,226,468	23,852,707	2,490,874	8,891,717	12.7	40.0	7.6	14.9
Germany.....	29,420,239	-----	-----	-----	36.6	-----	-----	-----
Netherlands.....	7,238,048	330,580	-----	187,423	9.0	.6	-----	.3
United Kingdom.....	8,847,965	10,765,070	4,827,806	18,830,926	11.0	18.0	14.7	31.9
Other countries.....	8,361,806	13,584,557	7,581,963	23,288,813	10.4	22.8	23.0	39.6
<b>Total.....</b>	<b>80,427,650</b>	<b>59,645,141</b>	<b>32,926,546</b>	<b>59,072,436</b>	<b>100.0</b>	<b>100.0</b>	<b>100.0</b>	<b>100.0</b>
<b>Fruits canned—</b>	<i>Dollars.</i>	<i>Dollars.</i>	<i>Dollars.</i>	<i>Dollars.</i>				
United Kingdom.....	2,715,863	3,627,823	3,029,606	9,909,951	68.5	59.1	43.1	67.9
Other countries.....	1,247,786	2,510,869	3,994,860	4,685,752	31.5	40.9	56.9	32.1
<b>Total.....</b>	<b>3,963,649</b>	<b>6,138,692</b>	<b>7,024,466</b>	<b>14,595,703</b>	<b>100.0</b>	<b>100.0</b>	<b>100.00</b>	<b>100.0</b>

1 Less than 0.05 of 1 per cent.

TABLE 281.—Destination of principal farm products exported from the United States, 1910-1919—Continued.

Article, and country to which consigned.	Quantity.				Per cent of total.			
	Year ending June 30—							
	Average, 1910-1914.	1917	1918	1919 (prel.)	Average, 1910-1914.	1917	1918	1919 (prel.)
<b>VEGETABLE MATTER—continued.</b>								
Glucose and grape sugar:	<i>Pounds.</i>	<i>Pounds.</i>	<i>Pounds.</i>	<i>Pounds.</i>				
Argentina.....	5,571,728	2,751,150	1,950,255	1,205,320	3.1	1.3	2.0	1.0
British Oceania.....	8,631,878	1,729,816	445,019	.....	4.8	.8	.5	.....
United Kingdom.....	145,950,270	160,716,035	55,825,847	62,687,250	80.8	74.8	57.0	52.7
Other countries.....	20,370,027	49,776,314	39,637,180	54,942,921	11.3	23.1	40.5	46.3
Total.....	180,523,903	214,973,315	97,858,301	118,835,491	100.0	100.0	100.0	100.0
Grain and grain products:								
Corn—	<i>Bushels.</i>	<i>Bushels.</i>	<i>Bushels.</i>	<i>Bushels.</i>				
Belgium.....	1,387,953	581,371	3,714,233	1,567,631	3.5	.9	9.1	9.4
Canada.....	8,379,334	15,724,838	7,895,892	8,939,735	21.0	24.3	19.3	53.3
Cuba.....	2,300,521	2,819,278	1,142,293	1,453,801	5.8	4.4	2.8	8.7
Denmark.....	2,493,820	7,075,254	.....	333,910	6.3	10.9	.....	2.0
Germany.....	5,231,554	.....	.....	.....	13.1	.....	.....	.....
Mexico.....	2,500,803	2,530,699	3,272,754	1,214,717	6.3	3.9	8.0	7.3
Netherlands.....	5,111,282	7,923,706	246,004	100,168	12.8	12.2	.6	.6
United Kingdom.....	10,906,171	24,493,817	21,197,784	2,522,397	27.4	37.8	51.7	15.1
Other countries.....	1,498,252	3,571,879	3,528,867	555,179	3.8	5.6	8.5	3.6
Total.....	39,809,690	64,720,842	40,997,827	16,687,538	100.0	100.0	100.0	100.0
Wheat—								
Belgium.....	7,195,138	2,698,044	6,007,986	25,972,439	12.6	1.8	17.6	14.5
Canada.....	1,776,247	4,714,836	252,540	26,484,027	3.1	3.1	.7	14.8
France.....	3,001,698	16,253,262	3,837,927	13,297,243	5.3	10.8	11.2	7.4
Germany.....	6,154,503	.....	.....	.....	10.8	.....	.....	.....
Italy.....	2,367,307	13,746,512	6,756,191	32,689,845	4.2	9.2	19.8	18.3
Japan.....	2,338,152	.....	.....	.....	4.1	.....	.....	.....
Mexico.....	1,178,864	54,597	2,126	.....	2.1	.....	(1)	.....
Netherlands.....	8,350,709	19,127,675	155,550	3,904,617	14.7	12.8	.5	2.2
United Kingdom.....	21,806,112	67,976,120	15,129,803	66,147,422	38.3	45.4	44.3	37.0
Other countries.....	2,744,498	25,260,381	1,976,730	10,087,080	4.8	16.9	5.9	5.8
Total.....	56,913,228	149,831,427	34,118,853	178,582,673	100.0	100.0	100.0	100.0
Wheat flour—	<i>Barrels.</i>	<i>Barrels.</i>	<i>Barrels.</i>	<i>Barrels.</i>				
Brazil.....	567,444	301,614	101,927	31,639	5.3	2.5	.5	.1
British West Indies.....	472,953	372,242	196,507	.....	4.4	3.1	.9	.....
Canada.....	82,821	77,115	83,334	193,025	.8	.6	.4	.8
China.....	263,882	9,806	275	.....	2.5	.1	(1)	.....
Cuba.....	856,239	1,016,675	679,689	1,058,028	8.0	8.5	3.1	4.4
Finland.....	243,856	.....	.....	.....	2.3	.....	.....	.....
Germany.....	187,457	.....	.....	.....	1.8	.....	.....	.....
Haiti.....	233,932	127,458	10,924	138,564	2.2	1.1	(1)	.6
Hongkong.....	1,121,139	61,800	1,250	1,506	10.5	.5	(1)	.....
Japan.....	612,879	4,083	69	.....	5.7	.....	(1)	(1)
Netherlands.....	818,637	591,182	69,253	1,117,018	7.7	5.0	.3	4.6
Norway.....	212,713	715,077	214,810	185,345	2.0	6.0	1.0	.8
Philippine Islands.....	278,717	76,089	549	6,039	2.6	.6	(1)	(1)
United Kingdom.....	2,712,639	3,015,525	10,055,827	10,745,508	25.4	25.2	46.0	44.4
Other countries.....	2,013,327	5,574,112	10,465,537	10,713,420	18.8	46.8	47.8	44.3
Total.....	10,678,635	11,942,778	21,879,951	24,190,092	100.0	100.0	100.0	100.0
Hops:	<i>Pounds.</i>	<i>Pounds.</i>	<i>Pounds.</i>	<i>Pounds.</i>				
British Oceania.....	516,882	451,189	31,760	.....	3.3	9.4	.9	.....
Canada.....	968,680	801,162	660,779	.....	6.2	16.6	18.9	.....
United Kingdom.....	13,880,669	823,654	102,896	.....	89.3	17.1	2.9	.....
Other countries.....	181,525	2,748,871	2,699,144	.....	1.2	56.9	77.3	.....
Total.....	15,547,756	4,824,876	3,494,579	7,466,952	100.0	100.0	100.0	100.0

1 Less than 0.05 of 1 per cent.

TABLE 281.—Destination of principal farm products exported from the United States, 1910-1919—Continued.

Article, and country to which consigned.	Quantity.				Per cent of total.			
	Year ending June 30—							
	Average, 1910-1914.	1917	1918	1919 (prel.)	Average, 1910-1914.	1917	1918	1919 (prel.)
<b>VEGETABLE MATTER—continued.</b>								
Oil cake and oil-cake meal:								
Cottonseed—	<i>Pounds.</i>	<i>Pounds.</i>	<i>Pounds.</i>	<i>Pounds.</i>				
Belgium.....	30,009,935	.....	.....	.....	3.2	.....	.....	.....
Denmark.....	335,176,189	673,151,482	4,704,000	83,839,215	35.9	58.5	10.5	26.9
Germany.....	316,183,442	.....	.....	.....	33.9	.....	.....	.....
Netherlands.....	55,879,799	23,231,880	.....	.....	6.0	2.0	.....	.....
Norway.....	28,019,121	71,814,963	.....	.....	3.0	6.2	.....	.....
United Kingdom.....	146,111,558	219,530,899	19,751,335	117,695,310	15.7	19.1	44.2	37.8
Other countries.....	21,908,452	162,430,467	20,225,458	110,091,580	2.3	14.2	45.3	35.3
Total.....	933,288,496	1,150,159,691	44,680,793	311,626,105	100.0	100.0	100.0	100.0
Linseed or flaxseed—								
Belgium.....	288,955,020	.....	.....	.....	43.7	.....	.....	.....
France.....	34,587,191	4,408,251	.....	150,640	5.2	.8	.....	.1
Netherlands.....	280,782,728	292,984,477	448,656	18,198,743	42.4	54.6	.3	9.0
United Kingdom.....	42,781,016	86,400,787	98,785,060	34,868,513	6.5	16.1	65.2	17.2
Other countries.....	14,712,925	153,190,879	52,166,261	149,570,377	2.2	28.5	34.5	73.7
Total.....	661,818,880	536,984,394	151,399,977	202,788,273	100.0	100.0	100.0	100.0
Oils, vegetable:								
Cottonseed—								
Argentina.....	9,300,144	2,863,997	1,971,552	944,835	3.4	1.8	2.0	.5
Austria-Hungary.....	4,951,218	.....	.....	.....	1.8	.....	.....	.....
Belgium.....	4,053,300	.....	.....	1,018,920	1.5	.....	.....	.6
Canada.....	20,345,315	40,902,325	40,859,087	33,473,443	7.5	25.7	40.5	18.7
Chile.....	4,320,237	1,787,089	1,912,903	1,882,852	1.6	1.1	1.9	1.1
Cuba.....	3,522,682	8,710,957	11,077,844	4,444,633	1.3	5.5	11.0	2.5
France.....	14,510,409	3,187,870	7,021,545	3,538,879	5.3	2.0	7.0	2.0
Germany.....	13,184,524	.....	.....	.....	4.9	.....	.....	.....
Italy.....	27,558,963	363,127	.....	11,213,437	10.2	.2	.....	6.3
Mexico.....	21,994,280	918,959	229,847	799,439	8.1	.6	.2	.4
Netherlands.....	58,258,887	28,034,879	.....	25,529,200	21.5	17.6	.....	14.3
Norway.....	7,512,668	33,591,436	572,765	8,486,421	2.8	21.1	.6	4.7
Roumania.....	3,010,554	.....	.....	.....	1.1	.....	.....	.....
Turkey, European.....	9,129,051	.....	.....	.....	3.4	.....	.....	.....
United Kingdom.....	39,832,247	14,172,497	27,888,581	47,736,329	14.7	8.9	27.7	26.7
Uruguay.....	3,666,681	1,066,275	755,270	63,450	1.4	.7	.8	(1)
Other countries.....	26,277,418	23,312,356	8,490,587	39,577,995	9.5	14.8	8.3	22.2
Total.....	271,428,578	158,911,767	100,779,981	178,709,833	100.0	100.0	100.0	100.0
Tobacco, leaf, stems, and trimmings: <sup>1</sup>								
Belgium.....	11,722,421	.....	75,523	13,615,413	3.0	.....	(2)	2.2
British Africa.....	6,233,693	10,410,254	8,611,717	10,422,711	1.6	2.5	3.0	1.7
British Oceania.....	13,984,064	15,927,720	6,786,008	17,793,685	3.6	3.9	2.3	2.8
Canada.....	15,149,901	15,275,422	17,577,987	23,282,916	3.9	3.7	6.1	3.7
China.....	7,061,404	9,887,842	7,959,312	14,699,427	1.8	2.4	2.8	2.4
France.....	42,503,455	70,514,607	73,372,601	97,088,976	10.8	17.1	25.4	15.5
French Africa.....	4,167,210	3,742,479	2,511,968	7,492,134	1.1	.9	.9	1.2
Germany.....	37,803,645	.....	.....	.....	9.6	.....	.....	.....
Italy.....	41,706,176	45,587,226	38,540,529	61,082,204	10.6	11.1	13.3	9.8
Japan.....	2,997,113	3,449,974	2,346,479	4,932,996	.8	.8	.8	.8
Netherlands.....	26,971,486	55,123,517	1,359,367	14,101,512	6.9	13.4	.5	2.3
Spain.....	20,111,895	10,692,009	17,890,064	25,510,069	5.1	2.6	6.2	4.1
United Kingdom.....	139,862,251	122,725,357	89,453,465	276,853,745	35.7	29.8	30.9	44.3
Other countries.....	21,908,357	48,262,453	22,685,666	58,428,725	5.5	11.8	7.8	9.2
Total.....	392,183,071	411,598,860	289,170,686	625,304,513	100.0	100.0	100.0	100.0

<sup>1</sup> Leaf only for 1918.<sup>2</sup> Less than 0.05 of 1 per cent.

TABLE 281.—Destination of principal farm products exported from the United States, 1910-1919—Continued.

Article, and country to which consigned.	Quantity.				Per cent of total.			
	Year ending June 30—							
	Average, 1910-1914.	1917	1918	1919 (prel.)	Average, 1910-1914.	1917	1918	1919 (prel.)
<b>FOREST PRODUCTS.</b>								
Naval stores:								
Rosin—	<i>Barrels.</i>	<i>Barrels.</i>	<i>Barrels.</i>	<i>Barrels.</i>				
Argentina.....	110,085	120,287	149,536	78,990	4.6	7.3	14.0	9.0
Austria-Hungary.....	76,883				3.2			
Belgium.....	140,413				5.8			
Brazil.....	155,226	147,462	158,824	89,266	6.5	9.0	14.8	10.1
Canada.....	80,882	172,578	129,070	90,915	3.4	10.5	12.1	10.3
Germany.....	727,521				30.2			
Italy.....	98,964	54,927	10,056	16,626	4.1	3.4	1.0	1.9
Netherlands.....	208,598	720		11,380	8.7			1.3
Russia, European.....	104,657	74,080			4.3	4.5		
United Kingdom.....	501,572	673,268	274,976	377,835	20.8	41.1	25.7	42.8
Other countries.....	201,675	395,268	348,467	216,765	8.4	24.2	32.4	24.6
Total.....	2,406,476	1,638,590	1,070,929	881,777	100.0	100.0	100.0	100.0
Turpentine, spirits of—	<i>Gallons.</i>	<i>Gallons.</i>	<i>Gallons.</i>	<i>Gallons.</i>				
Argentina.....	524,265	356,953	321,797	332,498	2.9	4.0	6.3	4.1
Belgium.....	1,748,419				9.7			
British Oceania.....	639,300	838,631	942,751	273,212	3.6	9.5	18.5	3.4
Canada.....	1,027,501	1,109,029	978,125	1,016,062	5.7	12.5	19.2	12.6
Germany.....	2,868,253				15.9			
Netherlands.....	3,166,749	66,892		492,163	17.6	.8		6.1
United Kingdom.....	6,774,171	5,327,100	1,413,732	4,175,590	37.7	60.2	27.7	51.8
Other countries.....	1,240,348	1,143,270	1,438,719	1,774,053	6.9	13.0	28.3	22.0
Total.....	17,989,006	8,841,875	5,095,124	8,063,578	100.0	100.0	100.0	100.0
Lumber—								
Fir—	<i>M feet.</i>	<i>M feet.</i>	<i>M feet.</i>	<i>M feet.</i>				
Australia.....		79,785	63,865	43,115		27.5	23.3	15.8
Canada.....		27,463	20,562	31,616		9.5	7.5	11.6
Chile.....		34,561	45,416	12,187		11.9	16.6	4.5
China.....		21,348	8,121	26,147		7.4	3.0	9.6
Japan.....		20,002	29,044	22,124		6.9	10.6	8.1
Mexico.....	( <sup>1</sup> )	6,033	8,091	7,381	( <sup>1</sup> )	2.1	3.0	2.7
New Zealand.....		4,017	3,283	5,237		1.4	1.2	1.9
Panama.....		17,919	4,769	10,535		6.2	1.7	3.9
Peru.....		38,539	51,053	39,543		13.3	18.6	14.5
United Kingdom.....		10,372	13,646	33,633		3.6	5.0	12.3
Other countries.....		29,941	26,413	40,980		10.2	9.5	15.1
Total.....	( <sup>1</sup> )	289,980	274,263	272,498	( <sup>1</sup> )	100.0	100.0	100.0
Oak—								
Argentina.....		4,535	3,444	5,066		8.4	5.1	5.0
Canada.....		36,908	47,183	42,217		68.3	70.2	41.9
France.....	( <sup>1</sup> )	455	474	1,701	( <sup>1</sup> )	.8	.7	1.7
United Kingdom.....		2,648	9,753	31,123		4.9	14.5	30.9
Other countries.....		9,484	6,362	20,742		17.6	9.5	20.5
Total.....	( <sup>1</sup> )	54,030	67,216	100,849	( <sup>1</sup> )	100.0	100.0	100.0
Pine, yellow, long leaf—								
Argentina.....		37,329	33,317	20,606		9.3	9.6	6.9
Brazil.....		3,266	2,050	255		.8	.6	.1
Canada.....		804	2,170	1,603		.2	.6	.5
Cuba.....		158,106	192,690	137,929		39.3	55.7	46.0
France.....		9,430	8,635	6,824		2.3	2.5	2.3
Italy.....		9,030	1,293	3,292		2.2	.4	1.1
Mexico.....	( <sup>1</sup> )	14,954	35,346	26,679	( <sup>1</sup> )	3.7	10.2	8.9
Panama.....		28,771	11,884	7,065		7.1	3.4	2.4
Spain.....		10,074	2,792	1,262		2.5	.8	.4
United Kingdom.....		59,011	10,220	39,724		14.7	3.0	13.2
Uruguay.....		4,841	3,961	5,552		1.2	1.1	1.9
Other countries.....		67,088	41,759	49,213		16.7	12.1	16.3
Total.....	( <sup>1</sup> )	402,704	346,117	300,004	( <sup>1</sup> )	100.0	100.0	100.0

<sup>1</sup> Not separately stated.

TABLE 281.—Destination of principal farm products exported from the United States, 1910-1919—Continued.

Article, and country to which consigned.	Quantity.				Per cent of total.			
	Year ending June 30—							
	Average, 1910-1914.	1917	1918	1919 (prel.)	Average, 1910-1914.	1917	1918	1919 (prel.)
FOREST PRODUCTS—CON.								
Naval stores—Con.								
Lumber—Con.								
Railroad ties—	<i>Barrels.</i>	<i>Barrels.</i>	<i>Barrels.</i>	<i>Barrels.</i>				
Canada.....	1,152,707	1,487,415	1,978,425	1,978,425	29.3	43.3	59.9	
Cuba.....	502,059	804,718	230,583	230,583	12.8	23.4	7.0	
France.....	281,612	97,187	49,305	49,305	7.2	2.8	1.5	
Honduras.....	(1)	79,906	70,379	25,431	(1)	2.0	.7	
Mexico.....	692,923	611,698	245,606	245,606	17.6	17.8	7.4	
United Kingdom..	685,718	18,069	646,021	646,021	17.4	.5	19.6	
Other countries...	539,182	345,831	125,928	125,928	13.7	10.2	3.9	
Total.....	(1)	3,934,107	3,435,297	3,301,299	(1)	100.0	100.0	100.0
Timber, sawed—								
Pitch pine, long leaf—								
Canada.....	1,584	1,830	227	227	1.1	2.8	.4	
France.....	12,477	2,020	3,694	3,694	8.3	3.1	5.9	
Italy.....	(1)	17,684	983	1,182	(1)	11.8	1.9	
United Kingdom	88,465	32,750	40,588	40,588	59.2	50.2	64.5	
Other countries.	29,317	27,650	17,237	17,237	19.6	42.4	27.3	
Total.....	(1)	149,527	65,233	62,928	(1)	100.0	100.0	100.0

<sup>1</sup> Not separately stated.

TABLE 282.—Origin of principal farm products imported into the United States, 1910-1919.

Article and country of origin.	Quantity.				Per cent of total.			
	Year ending June 30—							
	Average 1910-1914.	1917	1918	1919 (prel.)	Average 1910-1914.	1917	1918	1919 (prel.)
ANIMAL MATTER.								
Cattle:	<i>Number.</i>	<i>Number.</i>	<i>Number.</i>	<i>Number.</i>				
Canada.....	56,097	189,285	185,089	356,834	14.1	50.5	63.0	81.0
Mexico.....	339,616	183,827	105,470	82,340	85.4	49.0	35.9	18.7
Other countries.....	1,737	1,714	3,160	1,225	.5	.5	1.1	.3
Total.....	397,450	374,826	293,719	440,399	100.0	100.0	100.0	100.0
Horses:								
Canada.....	3,199	6,348	3,736	.....	22.6	50.4	73.2	.....
France.....	1,933	170	263	.....	13.6	1.4	5.1	.....
Mexico.....	6,846	5,331	795	.....	48.3	42.4	15.5	.....
Other countries.....	2,191	735	317	.....	15.5	5.8	6.2	.....
Total.....	14,169	12,584	5,111	4,003	100.0	100.0	100.0	100.0
Dairy products:								
Cheese, including substitutes—	<i>Pounds.</i>	<i>Pounds.</i>	<i>Pounds.</i>	<i>Pounds.</i>				
Argentina.....	.....	1,841,288	8,252,446	1,231,008	.....	12.7	83.9	50.4
France.....	4,142,716	1,937,341	1,026,117	452,452	8.4	13.4	10.4	18.5
Netherlands.....	3,365,038	249,371	.....	.....	6.8	1.7	.....	.....
Italy.....	20,834,962	8,482,280	16,044	57	42.3	58.6	.2	(1)
Switzerland.....	16,924,388	1,640,656	.....	.....	34.4	11.3	.....	.....
Other countries.....	3,953,013	330,578	544,698	758,789	8.1	2.3	5.5	31.1
Total.....	49,220,117	14,481,514	9,839,305	2,442,306	100.0	100.0	100.0	100.0

<sup>1</sup> Less than 0.05 of 1 per cent.

TABLE 282.—Origin of principal farm products imported into the United States, 1910-1919—Continued.

Article and country of origin.	Quantity.				Per cent of total.			
	Year ending June 30—							
	Average, 1910-1914.	1917	1918	1919 (prel.)	Average 1910-1914.	1917	1918	1919 (prel.)
ANIMAL MATTER—contd.								
Fibers, animal:								
Silk, raw—								
China.....	<i>Pounds.</i> 5,133,658	<i>Pounds.</i> 7,006,700	<i>Pounds.</i> 6,180,480	<i>Pounds.</i> 5,755,311	21.6	20.7	17.7	16.8
Italy.....	2,605,466	467,405	7,309	26,169	10.9	1.4	( <sup>1</sup> )	.1
Japan.....	15,591,700	26,341,833	28,645,529	28,440,400	65.5	77.8	82.2	82.8
Other countries.....	468,574	52,947	12,879	99,150	2.0	.1	.1	.3
Total.....	23,799,398	33,868,885	34,846,197	34,321,030	100.0	100.0	100.0	100.0
Wool, class 1:								
Argentina.....	22,406,577	187,078,443	161,981,865	121,579,497	27.0	66.9	53.3	37.1
Australia, Commonwealth of.....	17,221,074	802,618	29,956,449	77,600,344	20.7	.3	9.9	23.7
Belgium.....	1,442,467	.....	.....	.....	1.7	.....	.....	.....
British South Africa.....	140,462	23,473,031	55,757,397	47,878,642	.1	8.4	18.3	14.6
Chile.....	122,918	12,134,230	12,069,231	6,888,162	( <sup>1</sup> )	4.4	4.0	2.1
China.....	21,820	14,781,995	13,226,755	9,419,649	( <sup>1</sup> )	5.3	4.3	2.9
New Zealand.....	4,452,965	262,312	4,117,146	14,904,938	5.4	.0	1.3	4.5
United Kingdom.....	31,159,170	1,555,182	161,498	1,516,252	37.5	.6	.1	.4
Uruguay.....	4,204,432	33,304,462	17,785,170	34,386,870	5.1	11.9	5.9	10.5
Other countries.....	1,873,841	6,089,228	8,813,429	13,770,214	2.5	2.2	2.9	4.2
Total.....	83,045,726	279,481,501	303,868,940	327,944,568	100.0	100.0	100.0	100.0
Wool, class 2:								
Argentina.....	933,432	7,743,645	3,838,542	1,181,355	1.0	45.4	27.5	49.6
Canada.....	1,619,390	7,883,007	8,419,647	41,414	8.5	46.2	60.3	17.3
United Kingdom.....	14,328,023	56,400	.....	53,122	75.1	.3	.....	2.2
Other countries.....	2,190,057	1,372,901	1,695,768	736,660	15.4	8.1	12.2	30.9
Total.....	19,070,902	17,055,953	13,953,957	2,383,551	100.0	100.0	100.0	100.0
Wool, class 3:								
Argentina.....	3,834,849	15,075,173	15,258,176	16,690,943	3.7	22.3	25.9	19.8
British East Indies.....	3,924,193	428,661	41,309	47,040	3.7	.6	.1	.1
British South Africa.....	165,941	2,985,699	4,521,876	3,230,505	.1	4.4	7.6	3.8
Chile.....	51,960	3,250,229	5,231,980	16,125,000	( <sup>1</sup> )	4.8	8.9	19.2
China.....	32,806,474	25,448,769	24,432,434	28,747,295	31.2	37.6	41.4	34.2
Russia (Asiatic and European).....	21,015,422	.....	2,699,379	115,008	20.0	.....	4.6	.1
Turkey (Asiatic).....	6,939,783	9,889	.....	.....	6.6	.....	.....	.....
United Kingdom.....	23,114,951	2,795,512	138,367	5,985,785	22.0	4.1	.2	7.1
Other countries.....	13,270,122	17,678,739	6,671,141	13,236,877	12.7	26.2	11.3	15.7
Total.....	105,123,695	67,672,671	58,994,662	84,178,453	100.0	100.0	100.0	100.0
Packing-house products:								
Hides and skins, other than furs—								
Calf skins—								
Argentina.....	2,929,755	6,803,959	2,074,781	1,001,062	3.5	14.7	15.8	4.8
Belgium.....	4,238,167	.....	.....	.....	5.1	.....	.....	.....
Canada.....	6,267,359	2,752,316	2,382,544	2,398,851	7.5	5.9	18.1	11.6
Denmark.....	4,182,108	571,108	.....	2,270,891	5.0	1.2	.....	11.0
East Indies.....	2,132,857	18,687,201	3,442,034	6,088,808	2.6	40.3	26.2	29.5
France.....	4,874,163	2,437,902	70,236	.....	5.8	5.3	.5	.....
Germany.....	16,567,590	.....	.....	.....	19.8	.....	.....	.....
Netherlands.....	7,839,510	1,995,942	492,427	4,519,891	9.4	4.3	3.7	21.9
Norway.....	1,787,301	457,278	1,052,485	1,573,599	2.2	1.0	8.0	7.6
Russia (European).....	22,419,150	1,515,426	663,341	.....	26.8	3.3	5.0	.....
United Kingdom.....	4,501,812	5,259,334	234,854	20,000	5.4	11.4	1.8	.1
Other countries.....	5,778,631	5,855,729	2,748,613	2,775,323	6.9	12.6	20.9	13.5
Total.....	83,518,403	46,336,195	13,161,315	20,648,425	100.0	100.0	100.0	100.0

<sup>1</sup> Less than 0.05 of 1 per cent.

TABLE 282.—Origin of principal farm products imported into the United States, 1910-1919—Continued.

Article and country of origin.	Quantity.				Per cent of total.			
	Year ending June 30—							
	Average 1910-1914.	1917	1918	1919 (prel.)	Average 1910-1914.	1917	1918	1919 (prel.)
ANIMAL MATTER—contd.								
Packing-house products—Continued.								
Hides and skins, other than furs—Contd.								
Cattle hides—								
	<i>Pounds.</i>	<i>Pounds.</i>	<i>Pounds.</i>	<i>Pounds.</i>				
Argentina.....	71,324,202	118,987,435	103,468,863	93,884,903	28.1	30.8	38.7	37.0
Belgium.....	9,238,890				3.6			
Brazil.....	1,745,003	49,918,402	19,213,317	12,768,526	.7	12.9	7.2	5.0
Canada.....	35,445,887	23,240,504	29,353,473	29,235,448	14.0	6.0	11.0	11.5
China.....	4,957,534	25,084,323	12,451,439	3,066,663	2.0	6.5	4.6	1.2
Colombia.....	5,634,740	15,340,041	13,837,098	8,609,586	2.2	4.0	5.2	3.4
Cuba.....	4,516,358	13,487,275	12,065,247	11,949,928	1.8	3.5	4.5	4.7
East Indies.....	4,965,027	17,175,504	1,286,286	2,096,708	2.0	4.4	.5	.8
France.....	17,583,731	520,894	54,379	12,280	6.9	.1	(1)	(1)
Germany.....	8,288,419				3.3			
Italy.....	3,452,654	219,402			1.4	.1		
Mexico.....	29,277,132	36,137,722	23,851,700	26,223,766	11.6	9.3	8.9	10.3
Netherlands.....	6,142,184	5,029,905	623,220	835,992	2.4	1.3	.2	.3
Russia (European).....	9,492,894				3.7			
United Kingdom.....	9,167,276	3,528,480	205,830	92,313	3.6	.9	.1	.1
Uruguay.....	12,911,444	38,138,800	25,693,227	42,311,615	5.1	9.9	9.6	16.7
Venezuela.....	5,065,636	8,053,116	4,772,413	4,152,442	2.0	2.1	1.8	1.6
Other countries.....	14,220,934	31,738,225	20,623,278	18,636,560	5.6	8.2	7.7	7.4
Total.....	253,429,945	386,600,028	267,499,770	253,876,730	100.0	100.0	100.0	100.0
Goatskins—								
Aden.....	3,656,513	3,499,925	2,031,272	2,957,155	3.8	3.3	3.0	3.3
Africa, n. e. s.....	1,530,418	1,188,170	777,700		1.6	1.1	1.2	
Argentina.....	3,944,343	5,566,223	2,739,243	3,805,582	4.1	5.3	4.1	4.3
Brazil.....	3,621,530	4,601,848	3,324,871	3,856,685	3.8	4.4	5.0	4.3
British Africa.....	2,241,731	5,812,957	3,523,177	3,778,134	2.3	5.5	5.3	4.2
China.....	9,394,904	21,340,353	12,105,273	16,438,008	9.8	20.2	18.1	18.5
East Indies.....	41,905,364	46,196,646	33,493,842	43,550,752	43.7	43.7	50.0	48.9
France.....	2,543,276	1,046,413	190,967	406,940	2.7	1.0	.3	.5
Mexico.....	5,534,421	4,642,396	2,629,706	2,934,511	5.8	4.4	3.9	3.3
Russia (European).....	5,425,651				5.7			
United Kingdom.....	5,180,243	2,181,609	352,567	843,136	5.4	2.1	.5	1.0
Venezuela.....	1,561,559	1,817,928	1,266,543	1,620,252	1.6	1.7	1.9	1.8
Other countries.....	9,281,854	7,745,848	4,497,776	8,813,373	9.7	7.3	6.7	9.9
Total.....	95,821,807	105,640,307	66,932,937	89,004,528	100.0	100.0	100.0	100.0
Sheepskins—								
Aden.....	779,218	1,689,783	909,940	2,019,451	1.2	1.8	1.7	3.3
Argentina.....	5,270,655	22,698,632	14,644,079	12,263,864	8.1	23.7	26.4	19.8
Brazil.....	1,244,866	2,326,475	1,346,169	1,546,557	1.9	2.4	2.4	2.5
British India.....	2,887,204	5,091,787	2,490,592	4,217,285	4.4	5.3	4.5	6.8
British Oceania.....	7,716,554	10,879,286	10,364,512	23,153,461	11.9	11.4	18.7	37.4
British S. Africa.....	1,408,522	6,816,419	9,725,641	5,599,187	2.2	7.1	17.5	9.1
Canada.....	2,109,858	2,699,873	1,819,375	2,840,003	3.2	2.8	3.3	4.6
China.....	712,493	4,861,649	1,983,559	2,150,391	1.1	5.1	3.6	3.5
France.....	2,637,365	1,362,709	413,334	26,984	4.1	1.4	.7	(1)
Russia (European).....	6,334,259			1,769	9.7			(1)
United Kingdom.....	28,434,981	17,622,773	3,543,102	1,261,675	43.7	18.4	6.4	2.0
Uruguay.....	2,332,322	5,101,569	1,564,089	1,343,269	.4	5.3	2.8	2.2
Other countries.....	5,297,708	14,579,643	6,664,523	5,471,619	8.1	15.3	12.0	8.8
Total.....	65,077,005	95,730,598	55,468,915	61,895,515	100.0	100.0	100.0	100.0
VEGETABLE MATTER.								
Cocoa, crude:								
Brazil.....	17,128,176	51,461,624	91,351,529	52,038,036	12.1	15.2	22.9	16.6
British West Africa.....	9,288	40,424,917	99,397,070	112,790,884	(1)	12.0	24.9	36.0
British West Indies.....	36,119,338	60,139,918	51,438,970	21,625,543	25.5	17.7	12.9	6.9
Dominican Republic.....	24,818,840	61,443,869	39,851,184	39,406,460	17.5	18.1	10.0	12.6
Ecuador.....	19,120,725	67,227,698	76,786,657	57,123,389	13.5	19.9	19.2	18.3
Portugal.....	18,751,436	16,551,624	134,904		13.2	4.9	(1)	
United Kingdom.....	8,534,723	11,650,811	1,038,142	695,082	6.0	3.4	.3	.2
Venezuela.....	4,719,067	16,493,654	20,829,600	12,988,814	3.3	4.9	5.2	4.2
Other countries.....	12,598,842	13,259,761	18,212,345	16,369,211	8.9	3.9	4.6	5.2
Total.....	141,800,435	338,653,876	399,040,401	313,037,419	100.0	100.0	100.0	100.0

<sup>1</sup> Less than 0.05 of 1 per cent.



TABLE 282.—Origin of principal farm products imported into the United States, 1910-1919—Continued.

Article and country of origin.	Quantity.				Per cent of total.			
	Year ending June 30—							
	Average 1910-1914.	1917	1918	1919 (prel.)	Average 1910-1914.	1917	1918	1919 (prel.)
VEGETABLE MATTER—continued.								
Coffee:	<i>Pounds.</i>	<i>Pounds.</i>	<i>Pounds.</i>	<i>Pounds.</i>				
Brazil.....	673,058,602	907,197,562	743,958,456	571,921,573	74.8	68.7	65.0	54.7
Central American States and British Honduras.....	38,789,033	133,289,460	166,292,751	158,343,135	4.3	19.1	14.5	15.1
Colombia.....	70,516,164	150,591,659	112,159,390	121,416,418	7.8	11.4	9.8	11.6
East Indies.....	9,893,785	4,024,243	4,773,288	13,583,963	1.1	.3	.4	1.3
Mexico.....	31,220,334	54,908,223	31,118,513	21,963,490	3.5	4.2	2.7	2.1
Netherlands.....	2,565,776	150,000	.....	.....	.3	.....	.....	.....
Venezuela.....	45,806,538	58,050,584	50,122,484	85,007,646	5.1	4.4	4.4	8.1
West Indies and Bermuda.....	5,614,876	9,661,212	30,240,917	57,024,026	.6	.7	2.6	5.5
Other countries.....	21,874,219	1,997,859	5,225,090	16,769,023	2.5	.2	.6	1.6
Total.....	899,339,327	1,319,870,802	1,143,890,889	1,046,029,274	100.0	100.0	100.0	100.0
Fibers, vegetable:								
Cotton—								
Egypt.....	77,876,828	88,772,585	47,532,526	51,689,818	70.2	60.4	46.0	49.9
Peru.....	5,544,333	5,885,836	9,417,672	12,514,772	5.0	4.0	9.1	12.1
United Kingdom....	7,687,013	13,817,744	14	649,423	6.9	9.4	(1)	.6
British India.....	2,533,063	1,957,332	3,147,235	1,617,976	2.3	1.3	3.0	1.6
Mexico.....	7,761,757	16,428,482	17,862,209	27,217,580	7.0	11.2	17.3	26.3
Other countries.....	9,554,004	20,199,656	25,365,991	9,902,625	8.6	13.7	24.6	9.5
Total.....	110,956,998	147,061,635	103,325,647	103,592,194	100.0	100.0	100.0	100.0
Flax—	<i>Long tons.</i>	<i>Long tons.</i>	<i>Long tons.</i>	<i>Long tons.</i>				
Belgium.....	2,100	.....	.....	.....	19.5	.....	.....	.....
Canada.....	550	909	762	4,277	5.1	11.5	13.6	49.4
Russia (European)..	2,862	2,872	2,955	1,953	26.6	36.3	52.7	22.5
United Kingdom....	4,308	3,814	1,129	1,201	40.1	48.2	20.1	13.9
Other countries.....	932	323	761	1,228	8.7	4.0	13.6	14.2
Total.....	10,752	7,918	5,607	8,659	100.0	100.0	100.0	100.0
Jute and jute butts—								
British East Indies..	89,320	109,685	77,573	.....	95.9	97.3	99.1	.....
Other countries.....	3,843	3,010	739	.....	4.1	2.7	.9	.....
Total.....	93,163	112,695	78,312	53,218	100.0	100.0	100.0	100.0
Manila fiber—								
Philippine Islands..	70,513	76,300	86,065	.....	98.0	99.4	99.8	.....
Other countries.....	1,409	465	155	.....	2.0	.6	.2	.....
Total.....	71,922	76,765	86,220	67,844	100.0	100.0	100.0	100.0
Sisal grass—								
Mexico.....	128,314	130,861	137,343	.....	91.4	91.3	91.5	.....
Other countries.....	12,001	12,546	12,821	.....	8.6	8.7	8.5	.....
Total.....	140,315	143,407	150,164	153,455	100.0	100.0	100.0	100.0
Fruit:								
Bananas—	<i>Bunches.</i>	<i>Bunches.</i>	<i>Bunches.</i>	<i>Bunches.</i>				
British West Indies.	14,404,120	2,191,516	2,064,274	5,441,461	33.0	6.3	6.0	15.4
Central American States and British Honduras.....	23,010,323	26,323,639	25,895,734	24,101,286	52.7	7.0	75.0	68.1
Cuba.....	2,388,024	2,184,110	1,151,165	1,267,440	5.5	6.3	3.3	3.6
South America.....	2,344,511	3,578,500	5,214,500	4,235,944	5.4	10.3	15.1	12.0
Other countries.....	1,536,446	383,414	224,240	336,175	3.4	1.1	.6	.9
Total.....	43,683,424	34,661,179	34,549,913	35,382,306	100.0	100.0	100.0	100.0

<sup>1</sup> Less than 0.05 of 1 per cent.

TABLE 282.—Origin of principal farm products imported into the United States, 1910-1919—Continued.

Article and country of origin.	Quantity.				Per cent of total.			
	Year ending June 30—							
	Average 1910-1914.	1917	1918	1919 (prel.)	Average 1910-1914.	1917	1918	1919 (prel.)
VEGETABLE MATTER—continued.								
Nuts:								
Walnuts—	<i>Pounds.</i>	<i>Pounds.</i>	<i>Pounds.</i>	<i>Pounds.</i>				
Austria-Hungary....	842,698				2.			
China.....	2,155,291	7,612,023	2,084,108	3,220,646	6.4		8.9	29.4
France.....	21,026,019	18,302,907	9,099,952	2,480,527	62.5	47.3	39.1	22.7
Italy.....	5,754,825	7,822,612	6,260,317	422,234	17.1	20.2	26.9	3.9
Turkey (Asiatic)....	1,249,497				3.7			
Other countries....	2,638,219	4,987,820	5,844,793	4,813,223	7.8	12.9	25.1	44.0
Total.....	33,666,549	38,725,362	23,289,170	10,936,630	100.0	100.0	100.0	100.0
Oils, vegetable:								
Olive, edible—	<i>Gallons.</i>	<i>Gallons.</i>	<i>Gallons.</i>	<i>Gallons.</i>				
France.....	864,796	726,771	227,617	60,533	17.7	9.6	9.0	1.4
Italy.....	3,293,220	2,882,535	200,403	628	67.5	38.3	7.9	( <sup>1</sup> )
Spain.....	292,434	3,776,581	2,091,400	4,203,827	6.0	50.1	82.4	8.2
Other countries....	426,173	147,262	18,092	18,148	8.8	2.0	.7	.4
Total.....	4,876,623	7,533,149	2,537,512	4,283,136	100.0	100.0	100.0	100.0
Soya-bean oil—								
China.....	<sup>2</sup> 1,327,548	12,911,549	12,470,720	9,773,315	7.0	7.9	3.7	4.1
Japanese—China....	<sup>2</sup> 2,195,714	82,320,382	237,442,917	151,172,444	<sup>2</sup> 11.6	50.6	70.5	63.8
Japan.....	<sup>2</sup> 9,253,941	67,169,454	86,830,583	74,883,510	<sup>2</sup> 48.9	41.3	25.8	31.6
United Kingdom....	<sup>2</sup> 4,617,154	10,130			<sup>2</sup> 24.4	( <sup>1</sup> )		
Other countries....	<sup>2</sup> 1,512,949	278,720	80,426	975,736	<sup>2</sup> 8.1	.2	( <sup>1</sup> )	.5
Total.....	18,907,306	162,690,235	336,824,646	236,805,005	100.0	100.0	100.0	100.0
Opium:								
Turkey (Asiatic and European).....	380,536	539			77.9	.7		
United Kingdom.....	68,587	65,356	126,173		14.0	75.3	79.9	
Other countries.....	39,387	20,857	31,661		8.1	24.0	20.1	
Total.....	488,510	86,812	157,834	345,514	100.0	100.0	100.0	100.0
Seeds:								
Flaxseed or linseed—	<i>Bushels.</i>	<i>Bushels.</i>	<i>Bushels.</i>	<i>Bushels.</i>				
Argentina.....	1,974,021	5,009,441	7,432,421	6,976,518	27.2	40.4	55.6	82.8
Belgium.....	147,273				2.0			
British India.....	836,366	122,596			11.5	1.0		
Canada.....	4,110,370	7,014,573	5,501,391	1,304,337	56.6	56.6	41.2	15.5
United Kingdom....	178,859				2.5			
Other countries....	11,323	247,378	432,717	146,031	.2	2.0	3.2	1.7
Total.....	7,258,212	12,393,988	13,366,529	8,426,886	100.0	100.0	100.0	100.0
Grass seed:								
Clover—	<i>Pounds.</i>	<i>Pounds.</i>	<i>Pounds.</i>	<i>Pounds.</i>				
Canada.....	5,128,518	5,654,366	4,697,881	9,290,368	20.0	31.1	58.9	82.1
France.....	7,979,405	10,047,945	1,317,004	1,420,677	31.1	55.3	16.5	12.6
Germany.....	6,556,388				25.5			
Italy.....	2,297,896	660	1,285,064	316,898	9.0		16.1	2.8
Other countries....	3,699,993	2,469,188	678,146	283,968	14.4	13.6	8.5	2.5
Total.....	25,662,200	18,172,159	7,978,095	11,311,911	100.0	100.0	100.0	100.0
Sugar, raw cane:								
Cuba.....	3,856,447,356	4,669,097,398	4,560,749,643	5,488,711,032	88.8	87.6	93.1	94.1
Dominican Republic..	10,302,955	114,367,301	14,395,335	4,390,594	.2	2.1	.3	.1
Dutch East Indies....	179,217,222	21,813			4.1			
Philippine Islands....	232,340,306	267,891,954	173,600,941	210,950,670	5.4	5.0	3.5	3.6
South America.....	39,733,149	158,107,460	75,980,455	31,228,275	.9	3.1	1.6	.5
Other countries.....	23,016,602	120,101,434	73,550,651	96,701,886	.6	2.2	1.5	1.7
Total.....	4,341,057,590	5,329,587,360	4,898,277,025	5,831,982,457	100.0	100.0	100.0	100.0

<sup>1</sup> Less than 0.05 of 1 per cent.<sup>2</sup> Average 3 years only, 1912-1914.

TABLE 282.—Origin of principal farm products imported into the United States, 1910-1919—Continued.

Article and country of origin.	Quantity.				Per cent of total.			
	Year ending June 30—							
	Average 1910-1914.	1917	1918	1919 (prel.)	Average 1910-1914.	1917	1918	1919 (prel.)
<b>VEGETABLE MATTER—continued.</b>								
<b>Tea:</b>	<i>Pounds.</i>	<i>Pounds.</i>	<i>Pounds.</i>	<i>Pounds.</i>				
Canada.....	2,787,373	3,160,459	1,914,169	2,375,497	2.9	3.1	1.3	2.2
China.....	22,932,930	19,810,428	21,082,866	10,322,467	24.1	19.2	13.9	9.5
East Indies.....	10,500,188	13,139,514	74,164,326	37,126,368	11.0	12.7	49.0	34.3
Japan.....	46,245,473	52,418,963	52,996,471	57,600,251	48.6	50.7	35.0	53.3
United Kingdom.....	11,620,183	13,857,721	487,063	13,738	12.2	13.4	.3	( <sup>1</sup> )
Other countries.....	1,040,002	977,325	670,037	733,781	1.2	.9	.5	.7
Total.....	95,126,149	103,364,410	151,314,932	108,172,102	100.0	100.0	100.0	100.0
<b>Tobacco leaf:</b>								
<b>Wrapper—</b>								
Dutch East Indies....	46	1,191,560	3,890,236	7,553,460	( <sup>1</sup> )	30.2	86.2	94.3
Netherlands.....	6,087,084	2,426,322	353,172	486	96.4	61.6	7.8	( <sup>1</sup> )
Other countries.....	227,105	324,054	271,836	453,776	3.6	8.2	6.0	5.7
Total.....	6,314,235	3,941,936	4,515,344	8,007,722	100.0	100.0	100.0	100.0
<b>Other leaf—</b>								
Cuba.....	25,147,491	23,417,539	20,366,787	20,356,332	52.0	55.5	27.2	28.4
Dominican Republic	26,285	2,829,100	15,242,017	16,008,083	.1	6.7	20.4	22.4
Germany.....	1,410,469	.....	.....	.....	2.9	( <sup>1</sup> )	.....	.....
Greece.....	1,079,079	6,700,925	18,626,083	19,639,777	2.2	15.9	24.9	27.4
Turkey (Asiatic).....	11,564,036	18,450	.....	.....	23.9	( <sup>1</sup> )	.....	.....
Turkey (European).....	8,110,601	10,051	.....	.....	16.8	( <sup>1</sup> )	.....	.....
Other countries.....	1,042,024	9,218,346	20,617,332	15,622,429	2.1	21.9	27.5	21.8
Total.....	48,379,985	42,194,411	74,852,219	71,626,621	100.0	100.0	100.0	100.0
<b>FOREST PRODUCTS.</b>								
<b>India rubber, crude:</b>								
Belgium.....	6,262,187	.....	.....	.....	5.9	.....	.....	.....
Brazil.....	40,290,919	56,818,966	41,277,914	46,407,924	38.1	17.0	10.6	11.5
Canada.....	92,028	2,229,868	4,247,287	7,004,959	.1	.7	1.1	1.7
Central American States and British Honduras.....	1,142,524	1,347,931	736,014	360,390	1.1	.4	.2	.1
East Indies.....	8,447,379	181,431,778	311,909,581	311,587,641	8.0	54.4	80.1	77.4
France.....	3,320,383	616,772	508,017	347,003	3.1	.2	.1	.1
Germany.....	7,266,443	.....	.....	.....	6.9	.....	.....	.....
Mexico.....	5,848,310	1,488,636	1,033,087	2,312,423	5.5	.4	.3	.6
Other South America..	2,395,691	6,273,506	6,747,699	5,205,886	2.3	1.9	1.7	1.3
Portugal.....	1,325,719	3,719,703	538,076	87,422	1.3	1.1	.1	( <sup>1</sup> )
United Kingdom.....	28,736,758	78,742,217	21,926,945	21,498,871	27.2	23.6	5.6	5.4
Other countries.....	607,902	704,334	674,395	7,659,012	.5	.3	.2	1.9
Total.....	105,736,243	333,373,711	389,599,015	402,471,531	100.0	100.0	100.0	100.0
<b>Wood:</b>								
<b>Cabinet woods, mahogany—</b>	<i>M feet.</i>	<i>M feet.</i>	<i>M feet.</i>	<i>M feet.</i>				
British Africa.....	6,197	13,345	7,667	12,161	11.5	31.2	14.8	25.2
Central American States and British Honduras.....	14,237	12,701	27,098	24,704	26.5	29.7	52.4	51.2
Mexico.....	11,204	8,229	11,230	7,224	20.9	19.2	21.7	15.0
United Kingdom.....	15,050	1,360	78	130	28.0	3.2	.2	.3
Other countries.....	6,996	7,145	5,608	4,042	13.1	16.7	10.9	8.3
Total.....	53,684	42,780	51,681	48,261	100.0	100.0	100.0	100.0
<b>Boards, planks, deals, and other sawed lumber—</b>								
Canada.....	937,069	1,155,916	1,253,507	.....	96.5	98.3	97.7	.....
Other countries.....	33,955	19,403	29,194	.....	3.5	1.7	2.3	.....
Total.....	971,024	1,175,319	1,282,701	980,010	100.0	100.0	100.0	100.0
<b>Wood pulp:</b>	<i>Long tons.</i>	<i>Long tons.</i>	<i>Long tons.</i>	<i>Long tons.</i>				
Canada.....	218,423	443,133	440,859	454,604	46.3	63.4	87.5	95.6
Germany.....	68,133	.....	.....	.....	14.4	.....	.....	.....
Norway.....	72,899	44,624	10,573	6,259	15.5	6.4	2.1	1.3
Sweden.....	93,584	209,254	41,791	9,844	19.8	29.9	8.3	2.1
Other countries.....	18,756	2,464	10,929	4,984	4.0	.3	2.1	1.0
Total.....	471,795	699,475	504,152	475,691	100.0	100.0	100.0	100.0

<sup>1</sup> Less than 0.05 of 1 per cent.

MISCELLANEOUS AGRICULTURAL STATISTICS.

CROP SUMMARY.

The December estimates of the Crop Reporting Board of the Bureau of Crop Estimates of the acreage, production, and value (based on prices paid to farmers on December 1) of important farm crops of the United States in 1919 and 1918, with the average for the five years 1913-1917, based on the reports of the correspondents and agents of the Bureau, are as follows (1918 figures revised).

TABLE 283.—Crop summary, 1919, 1918, and average 1913-1917.

Crop.	Acreage.	Production.			Farm value Dec. 1.	
		Per acre.	Total.	Unit.	Per unit.	Total.
<b>Corn:</b>					<i>Cents.</i>	<i>Dollars.</i>
1919.....	102,075,000	28.6	2,917,450,000	Bu.....	134.9	3,934,234,000
1918.....	104,467,000	24.0	2,502,665,000	do.....	136.5	3,413,240,000
Av. 1913-17.....	107,496,000	25.6	2,749,349,000	do.....	82.5	2,267,560,000
<b>Winter wheat:</b>						
1919.....	49,905,000	14.7	731,636,000	do.....	211.0	1,543,452,000
1918.....	37,130,000	15.2	565,099,000	do.....	206.3	1,165,995,000
Av. 1913-17.....	34,196,000	16.2	555,190,000	do.....	121.3	673,382,000
<b>Spring wheat:</b>						
1919.....	23,338,000	9.0	209,351,000	do.....	229.5	480,556,000
1918.....	22,051,000	16.2	356,339,000	do.....	200.9	715,831,000
Av. 1913-17.....	18,124,000	13.0	235,444,000	do.....	115.7	272,455,000
<b>All wheat:</b>						
1919.....	73,243,000	12.8	940,987,000	do.....	215.1	2,024,008,000
1918.....	59,181,000	15.6	921,438,000	do.....	204.2	1,881,826,000
Av. 1913-17.....	52,320,000	15.1	790,634,000	do.....	119.6	945,837,000
<b>Oats:</b>						
1919.....	42,400,000	29.4	1,248,310,000	do.....	71.7	895,603,000
1918.....	44,349,000	34.7	1,538,124,000	do.....	70.9	1,090,322,000
Av. 1913-17.....	40,583,000	32.8	1,331,287,000	do.....	48.3	643,187,000
<b>Barley:</b>						
1919.....	7,420,000	22.3	165,719,000	do.....	120.9	200,419,000
1918.....	9,740,000	26.3	256,225,000	do.....	91.7	234,942,000
Av. 1913-17.....	7,780,000	25.6	199,212,000	do.....	72.4	144,242,000
<b>Rye:</b>						
1919.....	7,063,000	12.5	88,478,000	do.....	134.5	119,041,000
1918.....	6,391,000	14.2	91,041,000	do.....	151.6	138,038,000
Av. 1913-17.....	3,151,000	15.9	50,001,000	do.....	109.0	54,489,000
<b>Buckwheat:</b>						
1919.....	790,000	20.6	16,301,000	do.....	147.4	24,026,000
1918.....	1,027,000	16.5	16,905,000	do.....	166.5	28,142,000
Av. 1913-17.....	824,000	17.8	14,691,000	do.....	100.7	14,792,000
<b>Flaxseed:</b>						
1919.....	1,683,000	5.3	8,919,000	do.....	438.9	39,145,000
1918.....	1,910,000	7.0	13,369,000	do.....	340.1	45,470,000
Av. 1913-17.....	1,756,000	7.9	13,818,000	do.....	182.2	25,170,000
<b>Rice:</b>						
1919.....	1,089,800	37.7	41,059,000	do.....	267.0	109,613,000
1918.....	1,118,550	34.5	38,606,000	do.....	191.8	74,042,000
Av. 1913-17.....	835,000	36.9	30,788,000	do.....	112.0	34,468,000
<b>Potatoes:</b>						
1919.....	4,013,000	89.2	357,901,000	do.....	161.4	577,581,000
1918.....	4,295,000	95.9	411,860,000	do.....	119.3	491,527,000
Av. 1913-17.....	3,812,000	96.0	366,046,000	do.....	88.0	322,292,000
<b>Sweet potatoes:</b>						
1919.....	1,029,000	100.7	103,579,000	do.....	133.3	138,085,000
1918.....	940,000	93.5	87,924,000	do.....	135.2	118,863,000
Av. 1913-17.....	730,000	94.8	69,209,000	do.....	82.1	56,843,000
<b>Hay, tame:</b>						
1919.....	56,348,000	1.62	91,326,000	Ton.....	\$20.15	1,839,967,000
1918.....	55,755,000	1.37	76,660,000	do.....	\$20.13	1,543,494,000
Av. 1913-17.....	52,026,000	1.52	78,921,000	do.....	\$12.51	987,297,000
<b>Hay, wild:</b>						
1919.....	15,686,000	1.11	17,340,000	do.....	\$16.67	289,120,000
1918.....	15,365,000	.94	11,479,000	do.....	\$15.23	220,487,000
Av. 1913-17.....	16,547,000	1.09	17,990,000	do.....	\$8.70	156,597,000
<b>All hay:</b>						
1919.....	72,034,000	1.51	108,666,000	do.....	\$19.59	2,129,087,000
1918.....	71,120,000	1.28	91,139,000	do.....	\$19.35	1,763,981,000
Av. 1913-17.....	68,573,000	1.41	96,911,000	do.....	\$11.80	1,143,894,000
<b>Tobacco:</b>						
1919.....	1,901,200	730.8	1,389,458,000	Lb.....	39.0	542,547,000
1918.....	1,647,100	873.7	1,439,071,000	do.....	28.0	402,264,000
Av. 1913-17.....	1,348,000	809.1	1,090,641,000	do.....	14.5	158,059,000
<b>Cotton:</b>						
1919.....	33,344,000	<sup>1</sup> 158.2	11,030,000	Bale.....	<sup>1</sup> 35.7	1,967,143,000
1918.....	36,008,000	<sup>1</sup> 159.6	12,040,532	do.....	<sup>1</sup> 27.6	1,663,633,000
Av. 1913-17.....	34,832,000	<sup>1</sup> 176.5	12,847,108	do.....	<sup>1</sup> 15.4	946,339,000
<b>Cottonseed:</b>						
1919.....			4,929,000	Ton.....	\$68.32	336,751,000
1918.....			5,360,000	do.....	\$65.20	349,490,000
Av. 1913-17.....			5,727,000	do.....	\$37.23	213,198,000

<sup>1</sup> Pounds per acre and cents per pound.

## CROP SUMMARY—Continued.

TABLE 283.—Crop summary, 1919, 1918, and average 1913-1917—Continued.

Crop.	Acreage.	Production.			Farm value Dec. 1.	
		Per acre.	Total.	Unit.	Per unit.	Total.
Clover seed:					<i>Cents.</i>	<i>Dollars.</i>
1919.....	686,000	1.6	1,099,000	Bu.....	\$26.45	29,067,000
1918.....	820,000	1.5	1,197,000	do.....	\$19.80	23,705,000
Sugar beets:						
1919.....	696,503	9.18	6,396,860	Ton.....	\$10.75	68,750,000
1918.....	594,010	10.01	5,948,798	do.....	\$10.00	59,494,000
A v. 1913-17.....	600,962	10.05	6,038,181	do.....	\$6.07	36,642,000
Beet sugar:						
1919.....	696,503	2,193	1,527,696,000	Lb.....		
1918.....	594,010	2,562	1,521,900,000	do.....		
A v. 1913-17.....	600,962	2,606	1,566,216,000	do.....		
Cane sugar (La.):						
1919.....	176,500	1,310	231,179,000	do.....		
1918.....	231,200	2,430	561,800,000	do.....		
A v. 1913-17.....	221,800	2,201	488,159,000	do.....		
Maple sugar and sirup (as sugar):						
1919.....	<sup>1</sup> 19,002,700	<sup>2</sup> 2.18	41,506,800	do.....	<sup>3</sup> 26.9	11,172,000
1918.....	<sup>1</sup> 19,312,200	<sup>2</sup> 2.72	52,513,000	do.....	<sup>3</sup> 23.1	12,122,000
Sugar-beet seed:						
1919.....	11,100	604	6,700,000	do.....		
1918.....	5,872	757	4,443,000	do.....		
Sorghum sirup:						
1919.....	386,200	86.3	33,312,000	Gall.....	107.5	35,826,000
1918.....	374,800	79.1	29,643,000	do.....	96.3	28,532,000
A v. 1913-17.....	208,965	88.7	18,539,000	do.....		
Peanuts:						
1919.....	1,251,400	26.6	33,263,000	Bush.....	240.0	79,839,000
1918.....	1,865,400	24.7	46,010,000	do.....	173.7	79,929,000
Beans (6 States):						
1919.....	1,018,000	11.3	11,488,000	do.....	\$4.28	49,181,900
1918.....	1,744,000	10.0	17,397,000	do.....	\$5.28	91,863,000
Kafirs (7 States):						
1919.....	4,893,000	25.8	126,058,000	do.....	129.7	163,452,000
1918.....	6,036,000	12.1	73,241,000	do.....	150.0	109,881,000
Broom corn (7 States):						
1919.....	271,600	.196	53,100	Ton.....	\$152.58	8,102,000
1918.....	366,000	.158	57,800	do.....	\$220.93	12,770,000
Onions (22 States):						
1919.....	47,635	269.4	12,833,500	Bush.....	212.8	27,307,000
1918.....	64,715	298.8	19,336,000	do.....	139.4	26,957,000
Cabbage (29 States):						
1919.....	68,135	6.5	443,400	Ton.....	\$56.28	24,955,000
1918.....	92,715	7.4	684,812	do.....	\$37.01	25,344,000
Hops (4 States):						
1919.....	23,900	1,227.9	29,346,000	Lb.....	77.2	22,656,000
1918.....	25,900	829.4	21,481,000	do.....	19.3	4,150,000
Cranberries (3 States):						
1919.....	26,100	20.7	541,000	Bbl.....	\$8.36	4,520,000
1918.....	25,400	13.9	352,000	do.....	\$10.77	3,791,000
Apples, total:						
1919.....			147,457,000	Bush.....	186.8	275,463,000
1918.....			169,625,000	do.....	132.8	225,190,000
A v. 1913-17.....			197,855,000	do.....	84.0	166,140,000
Apples, commercial:						
1919.....			26,174,000	Bbl.....	\$5.92	154,950,000
1918.....			24,743,000	do.....	\$5.12	126,684,000
Peaches:						
1919.....			50,434,000	Bush.....	190.7	96,169,000
1918.....			33,094,000	do.....	162.1	53,637,000
A v. 1913-17.....			48,837,000	do.....	108.0	52,721,000
Pears:						
1919.....			13,902,000	do.....	183.9	25,560,000
1918.....			13,362,000	do.....	137.8	18,419,000
A v. 1913-17.....			11,713,000	do.....	94.6	11,075,000
Oranges (2 States):						
1919.....			23,916,000	Box.....	\$2.68	64,169,000
1918.....			24,200,000	do.....	\$3.49	84,480,000
Soy beans:						
1919.....	168,000	14.3	2,402,000	Bush.....	\$3.46	8,304,000
1918.....	169,000	17.7	2,997,000	do.....	\$3.20	9,590,000
Cowpeas:						
1919.....	1,478,000	7.1	10,426,000	do.....	273.6	28,524,000
1918.....	2,003,000	6.2	12,427,000	do.....	231.4	28,756,000
Total:						
1919.....	359,287,073					14,060,299,000
1918.....	356,611,662					12,597,390,000

<sup>1</sup> Trees tapped.<sup>2</sup> Per tree.<sup>3</sup> May 15.

## STATES LEADING IN STAPLE CROPS.

TABLE 284.—Production of staple crops in leading States, millions of bushels, 1917-1919.

Crop.	1919		1918		1917	
	Million bushels.		Million bushels.		Million bushels.	
Corn.....	Iowa.....	416	Iowa.....	353	Illinois.....	418
Wheat.....	Kansas.....	151	North Dakota.....	106	North Dakota.....	56
Oats.....	Iowa.....	196	Iowa.....	245	Iowa.....	254
Barley.....	California.....	30	Minnesota.....	40	California.....	39
Rye.....	North Dakota.....	16	North Dakota.....	20	North Dakota.....	10
Rice.....	Louisiana.....	20	Louisiana.....	17	Louisiana.....	16
Buckwheat.....	Pennsylvania.....	6	Pennsylvania.....	6	New York.....	6
Kafirs (sorghum grains).....	Texas.....	59	Texas.....	24	Oklahoma.....	22
Potatoes.....	New York.....	40	New York.....	37	New York.....	38
Sweet potatoes.....	Alabama.....	14	Alabama.....	14	Alabama.....	14
Flaxseed.....	North Dakota.....	4	North Dakota.....	6	North Dakota.....	4
Beans (dry).....	California.....	4	California.....	9	California.....	8
Peanuts.....	Alabama.....	7	Alabama.....	12	Alabama.....	14
Apples (commercial).....	Washington.....	19	New York.....	18	Washington.....	14
Peaches.....	California.....	19	California.....	13	California.....	16
	Thousand tons.		Thousand tons.		Thousand tons.	
Hay (all).....	Nebraska.....	7,125	New York.....	5,430	New York.....	6,413
Broom corn.....	Oklahoma.....	27	Texas.....	19	Oklahoma.....	26
Sugar beets.....	Colorado.....	1,790	Colorado.....	1,363	Colorado.....	1,750
	Thousand bales.		Thousand bales.		Thousand bales.	
Cotton.....	Texas.....	2,700	Texas.....	2,697	Texas.....	23,125
	Million pounds.		Million pounds.		Million pounds.	
Tobacco.....	Kentucky.....	456	Kentucky.....	470	Kentucky.....	441

## VALUE OF FARM PRODUCTS.

TABLE 285.—Estimated value of farm products, 1879-1919, based on prices at the farm.

Year.	Total, gross (to be read as index numbers).	Crops.		Animals and animal products.	
		Value.	Per cent- age of total.	Value.	Percent- age of total.
1879 (census).....	\$2,212,540,987				
1889 (census).....	2,460,107,454				
1897.....	3,961,000,000	\$2,519,000,000	63.6	\$1,442,000,000	36.4
1898.....	4,339,000,000	2,760,000,000	63.6	1,579,000,000	36.4
1899 (census).....	4,717,069,973	2,998,704,412	63.6	1,718,000,000	36.4
1900.....	5,010,000,000	3,192,000,000	63.7	1,818,000,000	36.3
1901.....	5,302,000,000	3,385,000,000	63.8	1,917,000,000	36.2
1902.....	5,595,000,000	3,578,000,000	64.0	2,016,000,000	36.0
1903.....	5,887,000,000	3,772,000,000	64.1	2,116,000,000	35.9
1904.....	6,122,000,000	3,982,000,000	65.0	2,140,000,000	35.0
1905.....	6,274,000,000	4,013,000,000	64.0	2,261,000,000	36.0
1906.....	6,764,000,000	4,263,000,000	63.0	2,501,000,000	37.0
1907.....	7,488,000,000	4,761,000,000	63.6	2,727,000,000	36.4
1908.....	7,891,000,000	5,098,000,000	64.6	2,792,000,000	35.4
1909 (census).....	8,558,161,223	5,487,161,223	64.1	3,071,000,000	35.9
1910.....	9,037,000,000	5,486,000,000	60.7	3,551,000,000	39.3
1911.....	8,819,000,000	5,562,000,000	63.1	3,257,000,000	36.9
1912.....	9,343,000,000	5,842,000,000	62.5	3,501,000,000	37.5
1913.....	9,850,000,000	6,133,000,000	62.3	3,717,000,000	37.7
1914.....	9,895,000,000	6,112,000,000	61.8	3,783,000,000	38.2
1915.....	10,775,000,000	6,907,000,000	64.1	3,868,000,000	35.9
1916.....	13,406,000,000	9,054,000,000	67.5	4,352,000,000	32.5
1917.....	19,331,000,000	13,479,000,000	69.7	5,852,000,000	30.3
1918.....	22,480,000,000	14,331,000,000	63.8	8,149,000,000	36.2
1919 (preliminary).....	24,982,000,000	16,025,000,000	64.1	8,957,000,000	35.9

CROP VALUE PER ACRE.

TABLE 286.—Yearly value per acre of 10 crops combined.

[Corn, wheat, oats, barley, rye, buckwheat, potatoes, hay, tobacco, and cotton, which comprise nearly 90 per cent of the area in all field crops, the average value of which closely approximates the value per acre of the aggregate of all crops.]

1919.....	\$36.90	1905.....	\$13.28	1891.....	\$11.76	1877.....	\$12.00
1918.....	33.73	1904.....	13.26	1890.....	11.03	1876.....	10.80
1917.....	33.27	1903.....	12.62	1889.....	8.99	1875.....	12.20
1916.....	22.58	1902.....	12.07	1888.....	10.30	1874.....	13.25
1915.....	17.18	1901.....	11.43	1887.....	10.14	1873.....	14.19
1914.....	16.44	1900.....	10.31	1886.....	9.41	1872.....	14.86
1913.....	16.49	1899.....	9.13	1885.....	9.72	1871.....	15.74
1912.....	16.09	1898.....	9.00	1884.....	9.95	1870.....	15.40
1911.....	15.36	1897.....	9.07	1883.....	10.93	1869.....	14.67
1910.....	15.53	1896.....	7.94	1882.....	12.93	1868.....	14.17
1909.....	16.00	1895.....	8.12	1881.....	13.10	1867.....	15.09
1908.....	15.32	1894.....	9.06	1880.....	13.01	1866.....	14.17
1907.....	14.74	1893.....	9.50	1879.....	13.26		
1906.....	13.46	1892.....	10.10	1878.....	10.37		

AGGREGATE CROP-VALUE COMPARISONS.

TABLE 287.—Value of 13 crops and hypothetical value of all crops, with rank, 1909–1919.

The following tabulation gives the estimated total value of 13 crops—corn, wheat, oats, barley, rye, buckwheat, flaxseed, rice, potatoes, sweet potatoes, tame hay, tobacco, and lint cotton—in the United States, by States, in 1919, 1918, 1913–1917, and 1909; the value of all crops in 1909 (census); and the hypothetical value of all crops in other years, based upon ratio of the 13 crops to all crops in census year; also rank of States. The slight differences in the total value of crops in the United States between Tables 287 and 285 are due to different methods of estimating. In Table 287, where each State is shown separately, a more detailed method is used than is practicable in Table 285.

State.	Value of 13 crops (000 omitted).			Value all crops 1909 (census) (000 omitted).	Ratio value 13 crops to all crops in census 1909.	Hypothetical values of all crops (000 omitted).			Rank.	
	1919	1918	1909			1919	1918	1913–1917 5-year average.	1919	
									13 crops.	All crops.
Maine.....	\$70,432	\$54,282	\$27,836	\$39,318	71	\$99,200	\$76,454	\$63,475	34	35
New Hampshire..	23,351	16,504	9,233	15,976	58	40,260	28,455	22,648	45	45
Vermont.....	43,056	32,789	18,577	27,447	68	63,318	48,219	39,359	38	40
Massachusetts....	35,810	31,184	14,916	31,948	47	76,191	66,349	49,421	44	38
Rhode Island.....	4,503	4,142	2,030	3,937	52	8,660	7,965	5,658	48	48
Connecticut.....	44,888	37,592	14,872	22,488	66	68,012	56,958	37,656	37	39
New York.....	313,853	282,818	132,620	209,168	63	498,179	448,917	294,689	17	13
New Jersey.....	61,076	59,637	23,396	40,341	58	105,303	102,822	68,862	36	34
Pennsylvania.....	364,534	341,761	130,010	166,740	78	467,351	438,155	275,753	15	17
Delaware.....	18,964	18,907	6,543	9,122	72	26,339	26,260	16,374	46	46
Maryland.....	95,575	92,132	31,454	43,920	72	132,743	127,961	74,371	32	32
Virginia.....	242,147	209,147	71,153	100,531	71	341,052	294,573	183,589	25	24
West Virginia....	104,929	94,946	27,749	40,375	69	152,071	137,603	80,094	30	30
North Carolina....	491,881	407,238	102,783	142,890	72	683,168	565,608	258,940	5	4
South Carolina....	400,802	351,508	109,699	141,983	77	520,522	456,504	212,168	13	11
Georgia.....	478,327	466,592	176,959	226,595	78	613,240	598,195	329,945	7	6
Florida.....	37,676	41,472	14,932	36,142	41	91,893	101,151	59,439	42	36
Ohio.....	488,173	449,962	197,288	230,338	86	567,643	523,212	315,724	6	7
Indiana.....	448,507	449,194	181,234	204,210	89	503,940	504,712	288,920	10	12
Illinois.....	748,111	807,027	342,861	372,270	92	813,164	877,203	480,858	3	3
Michigan.....	295,087	240,916	114,808	162,005	71	415,615	339,318	232,376	19	20
Wisconsin.....	355,092	340,968	121,048	148,359	82	433,039	415,815	234,507	16	18
Minnesota.....	433,030	483,811	168,706	193,451	87	497,736	556,105	281,121	12	14
Iowa.....	783,818	740,554	287,065	314,666	91	861,338	813,796	476,956	2	2
Missouri.....	466,739	409,354	188,524	220,664	85	549,105	481,593	294,125	9	8
North Dakota.....	252,012	356,534	168,292	180,636	93	270,981	383,370	176,262	24	27
South Dakota.....	279,524	357,522	109,353	125,507	87	321,292	410,945	188,957	22	25
Nebraska.....	478,264	340,233	173,512	196,126	88	543,482	386,628	316,120	8	9
Kansas.....	555,970	385,452	189,091	214,860	88	631,784	438,014	292,075	4	5
Kentucky.....	391,028	337,642	114,202	138,973	82	476,863	411,759	266,287	14	15
Tennessee.....	274,009	245,637	93,341	120,706	77	355,856	319,009	187,821	23	23
Alabama.....	289,204	260,878	108,095	144,287	75	385,605	347,837	197,196	20	22
Mississippi.....	307,522	297,896	107,054	147,316	73	421,263	408,077	205,114	18	19
Louisiana.....	177,360	180,762	47,577	77,336	62	286,065	291,552	162,887	27	26
Texas.....	902,048	580,001	244,721	298,133	82	1,100,059	707,318	553,935	1	1

## AGGREGATE CROP-VALUE COMPARISONS—Continued.

TABLE 287.—Value of 13 crops and hypothetical value of all crops, with rank, 1909–1919—Continued.

State.	Value of 13 crops (000 omitted).			Value all crops 1909 (census) (000 omitted).	Ratio value 13 crops to all crops in census 1909.	Hypothetical values of all crops (000 omitted).			Rank.	
	1919	1918	1909			1919	1918	1913–1917 5-year average.	1919	
									13 crops.	All crops.
Oklahoma.....	\$438,955	\$224,496	\$112,344	\$133,454	84	\$522,565	\$267,257	\$209,929	11	10
Arkansas.....	288,515	248,164	86,611	119,419	73	395,226	339,951	208,344	21	21
Montana.....	61,493	114,621	22,394	29,715	75	81,991	152,828	86,349	35	37
Wyoming.....	42,178	48,399	7,508	10,023	75	56,237	64,532	31,020	39	43
Colorado.....	126,837	107,245	31,416	50,975	62	204,576	172,976	98,035	29	28
New Mexico.....	39,752	25,404	5,591	8,922	63	63,098	40,324	21,460	41	41
Arizona.....	41,061	32,281	3,993	5,497	73	56,248	44,221	16,321	40	42
Utah.....	35,872	40,172	13,682	18,485	74	48,476	54,286	34,639	43	44
Nevada.....	14,229	16,930	4,082	5,924	69	20,622	24,536	16,665	47	47
Idaho.....	96,121	96,222	28,816	34,358	84	114,430	114,550	61,398	31	33
Washington.....	161,098	116,760	64,340	78,927	82	196,461	142,390	109,428	28	29
Oregon.....	94,561	82,727	33,140	49,041	68	139,060	121,657	81,690	33	31
California.....	223,368	167,538	71,994	153,111	47	475,251	356,464	259,289	26	16
United States...	12,421,342	11,127,953	4,357,445	5,486,615	79.4	15,796,573	14,094,384	8,392,249	.....	.....

## AGGREGATE CROP ACREAGES, BY STATES.

TABLE 288.—Acreage of 19 crops and theoretical acreage of all crops, 1909–1919.

[Crops included: Corn, wheat, oats, barley, rye, buckwheat, potatoes, sweet potatoes, tobacco, flax, rice, hay, cotton, peanuts, kafirs, beans, broom corn, hops, cranberries.]

State.	Acreage of given crops.				Acreage of all crops, 1909.	Per cent of given crops to all crops, 1909.	Theoretical acreage of all crops (in thousands; i. e., 000 omitted.)		
	1919	1918	1917	1909			1919	1918	1917
Maine.....	1,471,000	1,481,000	1,597,000	1,539,000	1,588,005	97	1,516	1,527	1,646
New Hampshire..	547,000	538,000	589,000	568,000	593,093	96	570	560	614
Vermont.....	1,134,000	1,139,000	1,194,000	1,138,000	1,203,795	94	1,206	1,212	1,270
Massachusetts....	554,000	552,000	605,000	590,000	654,844	90	616	613	672
Rhode Island.....	76,000	79,000	79,000	76,000	84,207	90	84	88	88
Connecticut.....	496,000	509,000	552,000	501,000	534,846	94	528	541	587
New York.....	7,879,000	7,983,800	8,049,000	7,911,000	8,387,731	94	8,382	8,493	8,563
New Jersey.....	1,051,200	1,019,700	1,063,000	999,000	1,114,903	90	1,168	1,133	1,181
Pennsylvania.....	8,177,000	8,052,600	8,133,500	7,637,000	7,826,562	98	8,344	8,217	8,299
Delaware.....	496,000	477,000	475,000	404,000	438,522	92	539	518	516
Maryland.....	2,150,000	2,088,000	2,008,600	1,788,000	1,934,954	93	2,312	2,245	2,160
Virginia.....	4,707,000	4,639,000	5,244,000	4,073,000	4,256,226	96	4,903	4,832	5,462
West Virginia....	2,278,000	2,205,600	2,169,300	1,799,000	1,874,382	96	2,373	2,298	2,260
North Carolina...	7,415,400	7,387,500	6,869,300	5,419,000	5,737,037	94	7,889	7,859	7,308
South Carolina...	6,499,700	6,381,900	6,020,000	4,810,000	5,152,845	93	6,989	6,862	6,473
Georgia.....	11,890,200	11,972,700	11,513,500	9,276,000	9,662,383	96	12,386	12,472	11,993
Florida.....	1,336,200	1,370,800	1,268,900	1,122,000	1,223,078	92	1,452	1,490	1,379
Ohio.....	11,496,000	11,134,000	10,969,200	11,153,000	11,431,610	98	11,731	11,361	11,193
Indiana.....	12,280,900	12,300,300	11,940,500	10,977,000	11,331,395	97	12,661	12,681	12,310
Illinois.....	20,823,900	21,235,800	20,725,700	19,938,000	20,273,916	98	21,249	21,669	21,149
Michigan.....	8,719,000	8,444,000	8,212,000	7,802,000	8,198,578	95	9,178	8,888	8,644
Wisconsin.....	9,147,900	9,036,700	8,824,700	8,233,000	8,555,080	96	9,529	9,413	9,192
Minnesota.....	15,932,000	15,738,000	15,126,000	14,515,000	14,731,464	99	16,093	15,897	15,279
Iowa.....	21,515,000	21,355,000	21,376,000	20,090,000	20,374,925	99	21,732	21,571	21,592
Missouri.....	14,733,900	14,787,250	13,916,800	13,925,000	14,335,588	97	15,190	15,245	14,347



AGGREGATE CROP ACREAGES, BY STATES—Continued.

TABLE 288.—Acreage of 19 crops and theoretical acreage of all crops, 1909–1919—Contd.

State.	Acreage of given crops.				Acreage of all crops, 1909.	Per cent of given crops to all crops, 1909.	Theoretical acreage of all crops (in thousands; i. e., 000 omitted.)		
	1919	1918	1917	1909			1919	1918	1917
North Dakota.....	17,472,000	18,020,000	16,815,000	15,728,000	15,888,756	99	17,648	18,202	16,985
South Dakota.....	14,825,000	14,735,000	14,469,000	11,916,000	12,226,772	97	15,284	15,191	14,916
Nebraska.....	18,831,000	18,298,000	18,519,000	16,984,000	17,231,205	99	19,021	18,483	18,706
Kansas.....	22,499,000	21,689,000	21,257,000	19,060,000	19,900,750	96	23,436	22,593	22,143
Kentucky.....	6,615,000	6,566,000	6,309,000	5,783,000	6,046,819	96	6,891	6,840	6,572
Tennessee.....	6,808,000	6,725,800	6,578,000	6,125,000	6,365,143	96	7,092	7,006	6,852
Alabama.....	9,449,600	9,573,100	9,533,600	6,977,000	7,205,239	97	9,742	9,869	9,828
Mississippi.....	7,821,300	7,894,000	7,338,100	5,968,000	6,158,719	97	8,063	8,138	7,565
Louisiana.....	4,405,400	4,530,300	4,160,600	3,182,000	3,586,348	89	4,950	5,090	4,675
Texas.....	24,607,000	23,509,000	23,818,200	17,414,000	18,389,092	95	25,902	24,746	25,072
Oklahoma.....	13,768,000	13,254,000	13,767,000	11,501,000	11,921,670	96	14,342	13,806	14,341
Arkansas.....	6,984,800	7,218,400	6,737,300	5,187,000	5,376,484	96	7,276	7,519	7,018
Montana.....	4,778,000	5,124,000	4,522,000	1,827,000	1,848,113	99	4,826	5,176	4,568
Wyoming.....	1,652,000	1,634,000	1,449,000	777,000	786,650	99	1,669	1,651	1,464
Colorado.....	4,474,000	4,369,000	3,491,000	2,323,000	2,614,312	89	5,027	4,909	3,922
New Mexico.....	1,288,000	960,000	1,080,000	422,000	632,769	67	1,922	1,433	1,612
Arizona.....	506,000	451,000	403,000	177,000	190,982	93	544	485	433
Utah.....	1,000,000	1,032,000	1,023,000	714,000	755,370	95	1,053	1,086	1,077
Nevada.....	432,000	444,000	498,000	391,000	392,387	99	436	448	503
Idaho.....	2,214,000	2,223,000	2,082,000	1,606,000	1,638,479	98	2,259	2,268	2,124
Washington.....	3,851,600	3,664,100	3,284,500	3,382,000	3,431,273	99	3,891	3,701	3,318
Oregon.....	2,793,000	2,706,000	2,606,000	2,236,000	2,281,288	98	2,850	2,761	2,659
California <sup>1</sup> .....	5,762,000	5,805,000	5,520,900	4,659,000	4,924,733	95	6,065	6,111	5,811
United States ..	355,643,000	352,332,350	343,782,200	300,622,000	311,293,382	96.6	368,809	365,197	356,341

<sup>1</sup> Includes cotton acreage in lower California (85,000 acres in 1919 and 88,000 acres in 1918).

WHEN CROPS ARE HARVESTED.

The tabulation below shows when crops are harvested in the United States by showing what proportion of the crop is usually harvested each month. Two factors tend to modify these percentages in any given year. In some years harvests come somewhat earlier or later than normal. Also, if the crop is larger than usual in its northern section and smaller than usual in its southern section, or vice versa, the effect is to modify the percentage of the total crop which is harvested in a particular month. However, it is not likely that such changes from normal are often so marked throughout the United States as to alter greatly the averages here given.

TABLE 289.—Percentage of crops of United States harvested monthly.

Crop.	January-April.	May.	June.	July.	August.	September.	October.	November.	December.
	<i>P. ct.</i>	<i>P. ct.</i>	<i>P. ct.</i>	<i>P. ct.</i>	<i>P. ct.</i>	<i>P. ct.</i>	<i>P. ct.</i>	<i>P. ct.</i>	<i>P. ct.</i>
Barley.....		1.2	8.2	51.6	33.9	4.9	0.2		
Buckwheat.....				.8	6.7	64.9	26.7	0.9	
Corn.....			.1	.1	1.5	15.8	28.3	43.3	10.9
Oats.....		1.0	7.9	52.9	34.2	3.8	.2		
Rice.....				.9	15.3	33.0	33.8	14.6	2.4
Rye.....		.2	11.3	71.5	16.3	.7			
Wheat.....		.5	22.0	42.3	28.4	6.5	.3		
Apples.....		.1	2.5	7.2	12.5	27.7	45.5	4.5	
Blackberries.....	0.1	1.8	15.4	47.6	27.1	6.2	1.7	.1	
Cantaloupes.....	.3	1.8	8.7	20.9	36.7	28.6	3.0		
Cranberries.....					7.3	67.1	25.6		
Grapes.....			.1	3.5	15.2	48.0	29.8	3.4	
Peaches.....		1.6	7.9	23.4	34.3	26.9	5.9		
Pears.....		.1	.4	7.5	25.1	44.4	21.5	1.0	
Raspberries.....		.5	16.5	58.4	21.7	2.8	.1		

## WHEN CROPS ARE HARVESTED—Continued.

TABLE 289.—Percentage of crops of United States harvested monthly—Continued.

Crop.	Jan- uary- April.	May.	June.	July.	Au- gust.	Sep- tem- ber.	Octo- ber.	No- vem- ber.	De- cem- ber.
Strawberries.....	4.8	23.6	49.4	18.3	3.1	.6	.1	.1	.....
Watermelons.....		.4	5.2	27.3	39.8	24.1	3.2	.....	.....
Beans (dry).....				.8	13.8	54.9	26.9	3.6	.....
Beans (lima).....	.1	.7	3.4	8.4	22.1	43.4	20.4	1.5	.....
Cabbage.....	4.2	2.3	4.7	6.8	9.1	18.1	40.4	14.0	.4
Onions.....	1.7	4.4	8.7	12.6	17.2	32.5	21.9	1.0	.....
Potatoes.....	.2	1.3	3.3	6.8	12.1	33.7	39.2	3.3	.1
Sweet potatoes.....	.1	.....	.1	1.7	6.2	21.5	49.1	20.6	.7
Tomatoes.....	3.1	1.3	3.8	11.4	29.2	39.7	9.7	1.5	.3
Hay, all.....	.2	2.2	15.3	47.8	21.8	10.7	1.9	.1	.....
Alfalfa.....	.9	5.3	24.1	28.0	21.5	16.4	3.7	.1	.....
Alfalfa seed.....			.6	10.7	30.5	45.1	13.0	.1	.....
Bluegrass seed.....		5.1	43.0	23.6	16.4	11.4	.5	.....	.....
Clover seed.....			.2	3.4	21.2	54.4	20.0	.8	.....
Millet.....		.2	1.7	16.4	40.5	37.2	4.0	.....	.....
Timothy hay.....			7.1	73.6	17.8	1.5	.....	.....	.....
Timothy seed.....			.8	36.1	54.0	9.1	.....	.....	.....
Wild hay.....	.2	.6	4.1	28.9	36.5	26.4	3.3	.....	.....
Broom corn.....			2.8	9.7	29.0	43.1	14.4	1.0	.....
Cotton.....	.4	.....	.....	1.4	11.5	31.6	34.4	16.0	4.7
Flaxseed.....			.1	3.0	31.5	56.5	8.9	.....	.....
Hops.....			.....	1.1	27.6	63.6	7.7	.....	.....
Peanuts.....			.1	2.1	12.5	39.3	37.7	8.0	.3
Sorghum (sirup).....			.1	1.4	13.3	51.9	30.9	2.4	.....
Sugar beets.....			.....	1.0	3.8	18.5	56.3	20.2	.2
Tobacco.....			.6	7.5	27.1	52.7	12.1	.....	.....

## COMPOSITE CROP YIELDS.

TABLE 290.—Composite numbers of all crop yields.

The figures below are obtained in the following manner: For each State the average yield per acre of each crop (as corn, wheat, cotton, etc.) is reduced to its 10-year average yield per acre; these percentages are combined into a composite or general average, viz., the figures shown. The relative importance of each crop is taken into consideration in making the composite averages.

State and division.	1919	1918	1917	1916	1915	1914	1913	1912	1911	1910
Maine.....	106	100	100	116	87	118	102	102	98	107
New Hampshire.....	105	106	110	122	85	114	89	119	93	109
Vermont.....	104	97	110	119	98	103	98	118	100	109
Massachusetts.....	103	98	105	110	96	116	96	107	90	102
Rhode Island.....	101	103	114	92	92	113	101	98	94	103
Connecticut.....	100	98	107	110	102	112	96	103	94	112
New York.....	107	102	108	108	100	111	91	105	90	107
New Jersey.....	97	100	102	107	107	105	101	106	89	107
Pennsylvania.....	105	102	101	106	101	106	98	110	91	103
North Atlantic.....	104.8	101.2	104.6	108.9	98.9	109.3	95.5	106.8	91.6	103.1
Delaware.....	91	91	104	101	99	109	97	112	96	106
Maryland.....	98	100	106	106	100	113	93	108	90	102
Virginia.....	102	105	108	113	114	90	107	101	91	108
West Virginia.....	102	99	103	110	113	95	93	123	78	97
North Carolina.....	92	106	97	95	103	108	104	102	100	104
South Carolina.....	94	98	102	83	92	104	106	102	103	102
Georgia.....	85	97	97	92	92	111	104	98	108	97
Florida.....	92	99	94	95	100	112	111	106	102	94
South Atlantic.....	93.1	100.3	100.7	102.9	99.6	105.1	103.5	103.6	99.6	101.3
Ohio.....	105	102	111	89	112	100	97	105	95	99
Indiana.....	95	110	109	92	113	93	95	102	95	106
Illinois.....	97	111	120	96	118	85	80	110	95	111
Michigan.....	100	90	98	93	100	111	94	101	98	101
Wisconsin.....	107	114	103	104	103	106	110	108	97	86
North Central east of Mis- sissippi River.....	100.6	106.0	110.0	94.7	110.6	96.9	92.8	106.1	95.5	101.7



## WHEN FEED IS CONSUMED ON FARMS.

The following tabulation shows what proportion of each important feedstuff is consumed in each month, 100 per cent being the year's consumption for each product. The percentages are derived from reports of about 30,000 crop reporters of the actual quantities usually fed monthly on their farms. Pasture, which is not shown here, is the important source of feed in the summer months.

TABLE 293.—*Monthly consumption of feedstuffs.*

Month.	Corn.	Oats.	Barley.	Rye.	Wheat.	Hay.	Silage.	Mill feed.
Year.....	100.0	100.0	100.0	100.0	100.0	100.0	100.0	100.0
January.....	11.0	7.1	8.9	7.6	10.0	14.1	16.5	10.9
February.....	10.7	7.3	9.0	7.2	9.2	14.2	16.8	11.5
March.....	10.2	8.4	9.1	7.5	9.2	14.2	16.2	11.5
April.....	9.0	9.8	8.5	9.1	8.3	12.0	13.7	10.6
May.....	6.8	9.3	6.9	8.1	7.2	6.7	5.3	7.7
June.....	5.5	8.9	6.0	7.8	6.5	3.7	1.1	5.8
July.....	4.8	9.0	6.0	7.1	5.8	3.3	1.0	4.8
August.....	4.6	9.3	6.8	8.4	5.9	3.2	1.0	5.4
September.....	6.2	9.1	8.6	10.2	7.3	3.6	1.5	5.7
October.....	8.8	8.1	9.8	10.3	8.9	5.2	4.1	6.3
November.....	10.9	6.9	10.9	9.4	11.4	8.5	9.5	9.2
December.....	11.5	6.8	9.5	7.3	10.3	11.3	13.3	10.6

## MONTHLY SALES FROM FARMS.

For every \$100 worth of product sold from the farm, about \$12.60 are sold in October, the month of heaviest total sales; \$11.70 in November, \$10.50 in December, and \$10.10 in September—in the four months, \$44.90. Smallest sales are in May and June, when the amount in each month is \$6.10 of the year's \$100.

Sales of crops alone are more concentrated in the fall months; for every \$100 worth of crops sold in a year, \$15.50 worth are sold in October, \$15.70 in November, \$12.60 in December, and \$12.40 in September; in the four months, \$56.20. Smallest sales (\$3.10) are in June.

Sales of live-stock products are fairly evenly distributed through the year. For every \$100 worth of live-stock products sold in a year \$9.60 are sold in June, the highest proportion in any month, and \$7.50 in January, the lowest.

These estimates are based upon reports made by crop correspondents of the Bureau of Crop Estimates of their actual sales in 1914, modified when necessary to make the figures typical of sales in recent years. More than 5,000 reports were tabulated. As the correspondents are representative farmers, the averages of their reports in the United States and in the larger States are probably nearly the same as the averages for all the farmers in the States. Details of monthly sales are given in tabulation below.

TABLE 294.—*Monthly percentages of year's receipts from sales by farmers.*

[Monthly rate of sales from farms, averages for recent years, estimates based upon reports of actual monthly sales made by crop correspondents of Bureau of Crop Estimates.]

## FROM SALES OF ALL KINDS.

State and division.	January.	February.	March.	April.	May.	June.	July.	August.	September.	October.	November.	December.	Year.
Maine.....	9.1	7.2	8.1	8.3	5.8	5.1	4.8	6.0	9.8	11.6	10.2	14.0	100.0
New Hampshire.....	9.3	9.4	7.6	10.3	6.1	5.8	8.4	8.2	7.9	10.2	8.4	8.4	100.0
Vermont.....	5.8	6.2	5.9	12.5	10.0	8.9	7.9	6.8	8.9	11.5	9.0	6.6	100.0
Massachusetts.....	5.6	5.2	6.1	7.9	5.9	6.9	9.6	10.8	10.3	12.2	10.3	9.2	100.0
Rhode Island.....	4.7	4.3	4.7	7.5	7.6	9.7	12.2	11.0	12.7	10.2	9.9	5.5	100.0
Connecticut.....	6.0	7.3	8.7	7.9	6.2	6.3	5.9	5.4	7.2	9.1	13.3	16.7	100.0
New York.....	7.1	6.4	7.1	7.9	7.4	7.9	7.5	7.1	9.2	12.3	12.4	7.7	100.0
New Jersey.....	3.5	3.0	4.7	3.4	5.0	5.9	11.5	20.9	21.8	8.9	5.3	6.1	100.0
Pennsylvania.....	7.5	6.8	9.5	8.3	10.1	6.0	6.0	8.3	9.4	9.8	10.1	8.2	100.0
North Atlantic.....	7.0	6.3	7.6	7.9	7.8	6.9	7.4	8.6	10.1	11.1	10.8	8.5	100.0
Delaware.....	11.2	7.0	6.9	5.8	11.3	10.6	9.3	8.4	5.7	8.7	8.6	6.5	100.0
Maryland.....	9.2	5.0	7.7	8.3	7.4	8.4	10.1	8.4	10.1	7.8	8.9	8.7	100.0
Virginia.....	8.3	7.4	7.0	6.2	6.2	6.8	8.8	7.4	8.1	16.3	9.1	8.4	100.0
West Virginia.....	4.8	5.6	6.9	4.6	4.8	7.0	7.4	8.6	13.1	23.2	6.8	7.2	100.0
North Carolina.....	9.2	5.2	4.3	6.6	3.4	3.4	4.2	4.2	6.7	12.3	18.4	22.1	100.0
South Carolina.....	11.5	5.7	7.1	5.1	2.9	3.1	3.4	4.9	11.1	14.4	16.3	14.5	100.0
Georgia.....	6.5	4.7	3.5	3.0	3.9	2.4	3.9	3.1	9.9	19.3	20.6	19.2	100.0
Florida.....	11.4	6.5	7.3	13.3	6.6	4.9	4.4	3.9	5.7	7.8	10.2	18.0	100.0
South Atlantic.....	8.4	5.8	5.8	5.8	4.7	4.8	5.9	5.6	9.0	15.6	14.1	14.5	100.0

MONTHLY SALES FROM FARMS—Continued.

TABLE 294.—Monthly percentages of year's receipts from sales by farmers—Continued.  
FROM SALES OF ALL KINDS—Continued.

State and division.	January.	February.	March.	April.	May.	June.	July.	August.	September.	October.	November.	December.	Year.
Ohio.....	10.1	6.8	8.2	7.0	6.2	9.0	8.4	8.9	9.3	8.5	7.6	10.0	100.0
Indiana.....	8.4	6.3	8.9	6.3	5.8	8.3	9.7	10.2	8.9	8.3	8.0	10.9	100.0
Illinois.....	7.1	7.3	10.3	7.8	9.2	8.6	7.1	7.8	9.7	6.4	9.2	9.5	100.0
Michigan.....	8.3	7.5	9.4	10.8	9.3	6.1	5.5	6.2	7.0	10.0	11.2	8.7	100.0
Wisconsin.....	9.2	7.9	8.2	8.4	7.7	8.4	6.8	6.4	8.4	10.1	9.7	8.8	100.0
North Central east of Mississippi River.....	8.4	7.0	9.2	7.7	7.6	8.3	7.7	8.3	9.0	8.1	8.9	9.8	100.0
Minnesota.....	9.6	7.6	9.4	7.4	6.7	5.4	4.4	3.7	10.1	12.9	12.2	10.6	100.0
Iowa.....	14.8	8.7	11.3	6.4	6.6	6.3	6.4	7.6	7.5	6.5	6.4	11.5	100.0
Missouri.....	7.8	8.5	6.1	7.8	6.6	6.4	8.3	9.8	8.9	8.3	9.9	11.6	100.0
North Dakota.....	7.2	5.2	6.2	5.6	5.9	7.2	3.9	6.9	12.2	18.0	12.6	9.1	100.0
South Dakota.....	6.9	4.7	5.5	4.5	3.2	3.7	4.2	3.7	16.5	20.0	16.9	10.2	100.0
Nebraska.....	10.6	9.7	8.4	8.3	7.0	7.4	7.3	6.5	10.9	8.0	8.2	7.7	100.0
Kansas.....	8.8	12.3	7.9	8.3	5.3	3.9	6.9	8.3	11.1	8.5	9.0	9.7	100.0
North Central west of Mississippi River.....	10.0	8.5	8.1	7.0	6.0	5.7	6.2	6.8	10.7	10.7	10.1	10.2	100.0
Kentucky.....	10.9	8.8	8.1	7.4	6.4	5.1	7.9	8.2	11.5	9.7	7.7	8.3	100.0
Tennessee.....	10.4	8.5	6.4	5.4	5.1	7.2	7.1	5.5	8.5	13.6	11.2	11.1	100.0
Alabama.....	8.1	6.8	9.3	5.5	3.0	3.3	3.1	5.2	7.7	15.0	17.1	15.9	100.0
Mississippi.....	10.1	2.7	3.9	3.4	2.8	2.4	2.6	2.2	6.9	19.8	23.6	19.6	100.0
Louisiana.....	8.0	6.9	4.9	3.7	3.3	3.0	5.4	4.2	14.8	19.9	16.1	9.8	100.0
Texas.....	5.9	3.6	4.0	4.4	5.5	1.9	3.5	4.1	16.1	21.2	16.9	12.9	100.0
Oklahoma.....	6.5	6.0	5.7	3.6	3.2	5.1	10.5	5.4	12.6	12.0	18.1	11.3	100.0
Arkansas.....	11.7	6.2	6.8	4.5	4.3	4.3	3.9	3.4	11.0	17.1	14.0	12.8	100.0
South Central.....	8.6	6.0	5.9	5.0	4.8	4.0	5.6	5.1	11.9	16.0	14.9	12.2	100.0
Montana.....	4.9	2.4	6.4	6.1	3.2	3.0	2.0	6.5	13.2	22.7	18.8	10.8	100.0
Wyoming.....	2.0	1.1	6.2	4.1	3.2	2.9	2.5	4.0	24.7	22.4	18.4	8.5	100.0
Colorado.....	9.8	8.0	4.9	9.6	4.4	4.3	3.6	3.1	6.2	16.4	21.9	7.8	100.0
New Mexico.....	3.9	2.8	4.6	15.0	4.1	2.2	1.5	1.7	9.7	35.9	11.5	7.1	100.0
Arizona.....	0.3	0.4	0.3	0.6	0.6	68.6	0.4	0.9	1.1	23.8	1.4	1.6	100.0
Utah.....	9.5	4.7	7.3	6.2	5.4	12.3	6.9	7.0	5.7	9.0	10.2	15.8	100.0
Nevada.....	6.5	7.2	4.2	17.4	15.7	2.9	8.4	16.9	3.6	3.7	6.3	7.2	100.0
Idaho.....	6.8	4.4	5.4	4.8	5.6	5.3	6.6	7.1	10.5	12.9	22.6	8.0	100.0
Washington.....	5.1	4.7	4.8	10.8	8.1	7.7	6.4	7.0	7.6	17.7	12.0	8.1	100.0
Oregon.....	3.2	2.5	3.7	4.3	4.4	8.1	7.4	10.6	6.5	25.4	14.3	9.6	100.0
California.....	6.4	4.2	5.5	7.4	5.0	6.8	4.9	6.1	9.3	20.0	16.0	8.4	100.0
Far Western.....	6.4	4.2	5.5	7.4	5.0	6.8	4.9	6.1	9.3	20.0	16.0	8.4	100.0
United States.....	8.5	6.8	7.4	6.9	6.1	6.1	6.4	6.9	10.1	12.6	11.7	10.5	100.0

FROM SALES OF CROPS.

Maine.....	11.9	5.5	9.7	6.8	2.2	1.8	1.1	2.5	12.0	18.6	14.3	13.6	100.0
New Hampshire.....	12.0	13.2	7.2	6.7	.8	2.0	11.4	13.2	7.4	12.1	6.5	7.5	100.0
Vermont.....	1.8	4.9	1.1	19.6	11.3	6.4	2.7	6.0	9.0	24.2	10.9	2.1	100.0
Massachusetts.....	1.7	1.9	3.6	5.8	2.1	5.9	7.1	11.4	16.4	20.2	13.7	10.2	100.0
Rhode Island.....	1.4	1.2	6.1	11.3	3.2	3.9	16.7	9.2	17.8	13.6	13.0	2.6	100.0
Connecticut.....	1.6	2.5	4.8	3.8	1.2	.4	1.9	2.7	3.8	9.4	31.6	36.3	100.0
New York.....	4.6	5.2	4.7	5.6	4.3	2.6	5.3	6.1	11.3	20.5	20.1	9.7	100.0
New Jersey.....	1.4	1.3	3.2	1.3	1.9	4.9	13.0	27.7	28.2	8.8	4.4	3.9	100.0
Pennsylvania.....	7.5	5.3	7.0	4.9	8.2	3.7	3.7	10.6	12.4	10.8	15.0	10.9	100.0
North Atlantic.....	5.3	4.5	5.5	5.1	4.8	3.3	5.8	10.4	13.9	15.4	15.7	10.3	100.0
Delaware.....	8.4	2.9	6.0	7.8	5.5	5.8	12.8	12.9	12.9	4.7	10.6	9.7	100.0
Maryland.....	11.0	8.9	5.7	4.4	3.5	3.8	13.9	12.3	7.3	8.4	12.3	8.5	100.0
West Virginia.....	14.5	15.2	4.0	3.9	3.0	2.6	5.1	9.5	8.7	13.8	9.7	10.0	100.0
North Carolina.....	8.8	3.2	3.5	7.1	1.7	2.3	2.7	2.1	4.5	14.6	22.3	27.2	100.0
South Carolina.....	11.0	4.6	6.2	2.3	1.3	1.9	2.0	4.7	11.7	16.9	20.1	17.3	100.0
Georgia.....	4.9	3.6	1.8	1.6	2.7	1.9	2.9	1.9	10.6	22.4	23.6	22.1	100.0
Florida.....	9.6	6.0	7.6	14.7	7.6	4.9	1.8	1.2	5.5	8.8	9.3	23.0	100.0
South Atlantic.....	8.7	5.0	4.3	4.5	2.7	2.7	5.1	5.0	8.5	15.3	19.0	19.2	100.0

## MONTHLY SALES FROM FARMS—Continued.

TABLE 294—Monthly percentages of year's receipts from sales by farmers—Continued.

## FROM SALES OF CROPS—Continued.

State and division.	January.	February.	March.	April.	May.	June.	July.	August.	September.	October.	November.	December.	Year.
Ohio.....	6.2	10.6	9.4	3.5	3.4	6.5	10.6	13.7	10.0	10.9	7.0	8.2	100.0
Indiana.....	8.9	6.1	5.8	4.5	4.2	3.4	17.0	17.2	11.1	8.8	6.7	6.3	100.0
Illinois.....	4.7	4.8	7.9	8.8	9.8	8.0	6.9	13.5	15.3	3.8	9.4	7.1	100.0
Michigan.....	8.6	7.6	6.6	8.9	5.2	3.5	4.3	6.8	9.3	14.6	14.6	10.0	100.0
Wisconsin.....	7.6	7.1	7.4	9.6	8.5	4.4	1.1	3.5	12.9	12.5	16.7	8.7	100.0
North Central east of Mississippi River.....	6.6	6.9	7.6	6.7	6.5	5.9	9.3	12.9	12.3	8.3	9.3	7.7	100.0
Minnesota.....	9.3	8.2	7.5	3.5	4.9	3.3	2.2	2.2	14.0	16.6	15.6	12.7	100.0
Iowa.....	11.2	5.5	6.8	4.5	8.2	3.1	8.1	7.4	16.1	8.7	6.9	13.5	100.0
Missouri.....	5.7	4.7	2.1	3.0	1.5	2.5	20.9	22.1	9.2	8.5	9.0	10.8	100.0
North Dakota.....	7.5	5.3	4.3	2.2	2.8	1.7	1.0	1.9	18.6	22.3	21.0	11.4	100.0
South Dakota.....	3.3	5.3	4.7	2.8	3.7	2.0	2.2	8.7	18.2	18.0	17.8	13.3	100.0
Nebraska.....	10.4	4.7	3.7	9.6	7.8	4.7	11.6	7.9	13.1	7.8	7.8	10.9	100.0
Kansas.....	6.6	9.7	10.4	6.5	2.6	1.2	9.8	10.8	12.8	7.5	9.6	12.5	100.0
North Central west of Mississippi River.....	8.1	6.3	5.8	4.6	4.4	2.6	7.1	7.3	15.0	13.6	13.2	12.0	100.0
Kentucky.....	15.5	11.8	10.5	5.9	4.5	2.1	9.2	9.8	8.3	3.4	7.0	12.0	100.0
Tennessee.....	10.6	6.7	5.9	5.2	5.4	7.9	11.8	6.7	4.0	8.7	14.1	13.0	100.0
Alabama.....	7.1	5.4	8.8	3.2	2.3	1.6	1.7	3.8	8.2	18.4	20.6	18.9	100.0
Mississippi.....	9.6	1.6	2.3	2.3	1.6	1.2	1.2	.8	6.4	22.1	28.3	22.6	100.0
Louisiana.....	7.0	3.3	4.2	2.0	1.6	2.0	5.4	4.2	18.6	22.9	18.8	10.0	100.0
Texas.....	3.9	2.1	2.4	2.6	.7	1.2	2.9	3.8	17.7	25.8	21.4	15.5	100.0
Oklahoma.....	5.4	4.3	2.2	2.0	2.2	2.6	15.0	7.4	16.8	15.0	16.7	10.4	100.0
Arkansas.....	7.9	2.2	3.7	2.2	.9	1.1	2.6	2.8	6.1	31.0	21.3	18.2	100.0
South Central.....	7.4	4.2	4.4	3.1	2.1	2.3	5.8	4.8	12.3	19.3	19.1	15.2	100.0
Montana.....	3.7	2.0	1.3	2.6	2.6	.1	.2	8.6	16.4	27.5	22.1	12.9	100.0
Wyoming.....	2.5	1.3	9.0	4.0	5.5	.4	.3	.7	2.5	16.9	42.0	14.9	100.0
Colorado.....	12.2	7.1	6.1	3.4	3.6	2.5	4.0	4.9	9.8	14.1	20.5	11.8	100.0
New Mexico.....	8.5	5.4	8.2	4.8	2.7	1.8	3.6	4.6	9.6	11.0	18.7	21.1	100.0
Arizona.....													
Utah.....	7.7	3.0	2.3	2.9	2.5	1.5	6.4	9.5	7.0	7.0	18.7	31.5	100.0
Nevada.....													
Idaho.....													
Washington.....	10.2	2.3	2.5	2.2	1.7	.9	1.7	3.9	14.9	15.8	38.0	5.9	100.0
Oregon.....	5.6	5.0	3.9	7.7	1.3	3.6	5.6	7.0	7.7	32.2	14.1	6.3	100.0
California.....	1.6	1.9	3.0	3.3	3.7	3.6	7.8	12.9	7.6	29.6	16.1	8.9	100.0
Far Western.....	7.1	3.2	4.0	4.0	3.0	2.6	5.0	8.2	10.2	22.8	19.7	10.2	100.0
United States.....	7.4	5.2	5.3	4.6	3.9	3.1	6.5	7.8	12.4	15.5	15.7	12.0	100.0

## FROM SALES OF LIVE STOCK.

North Atlantic.....	7.5	6.4	9.6	10.8	10.6	5.2	5.8	5.6	8.8	9.6	12.7	7.4	100.0
South Atlantic.....	8.0	5.6	7.7	6.1	5.9	6.3	5.9	5.4	10.4	21.4	8.4	8.9	100.0
North Central east of Miss. R.....	9.8	6.8	10.9	7.9	7.0	9.5	6.1	5.0	7.5	7.9	9.4	12.2	100.0
North Central west of Miss. R.....	12.6	10.3	10.1	7.9	6.0	6.9	4.9	6.5	7.7	9.3	8.3	9.5	100.0
South Central.....	9.9	8.6	8.0	7.1	4.2	5.2	5.0	5.4	12.5	13.6	11.1	9.4	100.0
Far Western.....	5.9	4.5	5.0	11.3	5.3	9.2	4.5	2.4	9.4	21.9	14.6	6.0	100.0
United States.....	10.3	8.1	9.2	8.2	6.2	7.4	5.3	5.5	8.7	11.8	9.8	9.5	100.0

## FROM SALES OF LIVE-STOCK PRODUCTS.

North Atlantic.....	7.8	7.6	8.3	8.7	9.2	9.1	8.7	8.4	8.0	8.7	7.7	7.8	100.0
South Atlantic.....	7.9	8.0	7.5	8.4	8.1	9.2	7.5	7.9	8.9	8.9	8.7	9.0	100.0
North Central east of Miss. R.....	8.0	7.4	8.4	9.1	10.0	9.5	8.6	7.7	7.7	7.9	7.8	7.9	100.0
North Central west of Miss. R.....	6.4	8.0	7.8	9.4	9.9	10.7	8.9	7.9	8.3	7.3	8.0	7.4	100.0
South Central.....	8.7	8.6	9.1	9.3	8.4	8.1	7.4	6.6	7.0	7.7	9.1	10.0	100.0
Far Western.....	6.3	5.9	7.0	8.0	8.5	10.7	8.7	8.6	7.4	10.4	10.6	7.9	100.0
United States.....	7.5	7.6	8.1	8.9	9.3	9.6	8.5	8.0	7.9	8.3	8.3	8.0	100.0

## RECEIPTS FROM FARM SALES.

About 10,000 crop correspondents of the Bureau of Crop Estimates have reported their year's total value of all sales of farm products, divided into four classes, viz, (1) live animals, (2) animal products, (3) crops, (4) miscellaneous. Correspondents were requested to give their 1914 sales if that year was representative; if 1914 sales were not normal, they were to give figures which would be typical of sales in recent years.

Of every \$100 worth of product sold by all who reported, approximately \$36 were for live animals, \$20 were for the products of live stock, \$40 were for crops, and \$4 represented miscellaneous items. As the correspondents are representative farmers, the averages of their reports in the United States and in the larger States are probably nearly the same as the averages for all the farmers in the States.

The character of farmers' sales varies widely in different sections of the country. In the cotton States, as would be expected, by far the greater part of the sales are as crops. Thus, in Georgia, for every \$100 worth of products sold, \$75 represents crops, \$14 live animals, \$8 animal products, and \$3 miscellany. Even in Texas, regarded as a cattle as well as a cotton State, cotton so far predominates that \$72 represents crops, \$16 live animals, and \$9 animal products, out of every \$100 of sales. It may be that the cattle section of the State is not so fully represented in the returns as the cotton section; but complete returns from all farmers probably would not materially modify these figures.

TABLE 295.—Receipts from the sale of (1) live stock, (2) live-stock products, (3) crops, (4) miscellaneous, out of every \$100 received from all sales; average of recent years.

[From tabulation of reports from crop correspondents of the Bureau of Crop Estimates.]

State.	Live stock.	Live-stock products.	Crops.	Mis-cellaneous.	State.	Live stock.	Live-stock products.	Crops.	Mis-cellaneous.
Maine.....	\$15	\$42	\$35	\$8	Minnesota.....	\$33	\$20	\$43	\$4
New Hampshire.....	20	51	25	4	Iowa.....	63	12	22	3
Vermont.....	18	64	10	8	Missouri.....	62	13	21	4
Massachusetts.....	19	50	27	5	North Dakota.....	25	6	66	3
Rhode Island.....	13	62	22	1	South Dakota.....	41	18	36	5
Connecticut.....	12	62	24	2	Nebraska.....	56	9	32	3
New York.....	14	53	27	6	Kansas.....	39	16	42	3
New Jersey.....	6	26	62	6	Kentucky.....	45	19	31	5
Pennsylvania.....	21	42	32	5	Tennessee.....	42	12	40	6
Maryland and Dela- ware.....	23	32	42	3	Alabama.....	17	14	66	3
Virginia.....	46	15	35	4	Mississippi.....	12	8	76	4
West Virginia.....	58	23	13	6	Louisiana.....	13	9	72	6
North Carolina.....	18	15	60	7	Texas.....	16	9	72	3
South Carolina.....	8	12	72	8	Oklahoma.....	32	11	53	4
Georgia.....	14	8	75	3	Arkansas.....	34	11	48	7
Florida.....	16	16	64	4	Mountain States <sup>1</sup> .....	49	13	34	4
Ohio.....	41	22	31	6	Washington.....	16	46	36	2
Indiana.....	50	16	30	4	Oregon.....	33	32	30	5
Illinois.....	42	20	35	3	California.....	15	12	72	14
Michigan.....	34	30	31	5					
Wisconsin.....	31	47	17	5	United States.....	36	20	40	4

<sup>1</sup> Including Montana, Wyoming, Colorado, New Mexico, Arizona, Utah, Nevada, and Idaho.

## PRODUCTION OF VEGETABLE SEEDS.

[Contributed by Bureau of Markets.]

The figures given for 1919 in the following table represent in the main a compilation of reports received from commercial growers giving the estimated (actual wherever possible) average yield per acre and total production of each vegetable seed crop grown by them. Those given for 1918 and 1917 were compiled from reports submitted in vegetable seed acreage and production surveys.

TABLE 296.—Acreage, yield per acre, and production of vegetable seeds, 1917-1919.

Kind of seed.	Commercial acreage planted.			Average yield per acre, based on acreage planted.			Commercial production.		
	1919	1918	1917	1919, estimated.	1918	1917	1919, estimated.	1918	1917
	<i>Acres.</i>	<i>Acres.</i>	<i>Acres.</i>	<i>Pounds.</i>	<i>Pounds.</i>	<i>Pounds.</i>	<i>Pounds.</i>	<i>Pounds.</i>	<i>Pounds.</i>
Beans, dwarf snap....	48,658	72,831	63,524	515	401	234	25,093,000	29,215,515	14,809,000
Beans, garden pole (not including lima)	7,957	7,482	4,029	540	691	315	4,395,000	5,166,159	1,268,000
Beet, garden.....	2,666	2,801	826	697	896	562	1,858,000	2,509,391	464,000
Beet, mangel.....	619	424	20	1,003	677	1,504	621,000	286,974	30,000
Beet, sugar.....	11,139	6,014	4,638	600	980	1,094	6,700,000	5,900,000	5,076,000
Cabbage.....	1,978	1,383	737	700	117	393	1,383,000	161,629	292,000
Carrot.....	3,465	4,894	1,965	450	471	574	1,562,000	2,125,060	1,129,000
Celery.....	135	176	84	400	228	335	54,000	40,201	28,100
Cucumber.....	3,582	3,177	4,694	214	173	218	766,300	548,044	1,026,000
Kale.....	106	49	18	406	342	250	43,000	16,744	4,500
Lettuce.....	2,283	2,291	1,979	298	326	457	679,800	746,993	903,000
Muskmelon.....	1,467	1,671	1,827	102	117	161	149,900	196,142	293,000
Watermelon.....	5,508	10,423	8,929	90	92	71	500,000	959,549	633,000
Onion seed.....	6,730	7,260	3,782	389	232	259	2,618,000	1,685,258	980,000
Onion sets.....	3,708	3,818	2,637	5,900	12,066	11,851	21,900,000	46,068,711	31,249,000
Parsley.....	146	155	109	764	468	772	111,500	72,553	84,000
Parsnip.....	303	267	137	732	626	499	222,000	167,199	68,000
Peas, garden.....	104,172	102,095	110,129	460	569	444	47,968,000	58,127,258	48,868,000
Pepper.....	160	657	686	75	86	31	12,000	56,195	21,000
Pumpkin.....	1,156	1,380	1,512	95	96	72	110,300	132,612	108,000
Radish.....	10,870	8,760	3,521	233	221	176	2,537,000	1,935,047	621,000
Salsify.....	205	124	131	452	247	431	92,600	30,647	56,000
Spinach.....	1,139	4,259	1,415	317	387	220	361,000	1,650,008	300,000
Squash, summer.....	1,153	1,004	836	195	99	145	223,000	99,404	121,000
Squash, winter.....	2,912	2,534	1,328	152	51	70	443,400	128,385	93,000
Sweet corn.....	14,565	14,759	12,975	900	807	640	13,143,000	11,916,892	8,303,000
Tomato.....	3,604	3,832	3,204	67	80	92	243,000	307,815	227,000
Turnip, English.....	1,207	936	24	380	215	127	456,000	200,783	3,000
Turnip, Swede.....	205	279	21	602	98	418	123,300	27,312	8,700

## WAR-TIME WHEAT PRICES.

Prices per 60 pounds of wheat, for calendar years 1913 to 1918, in countries and markets indicated, computed from data in Bulletin 2 of the War Industries Board. Foreign prices translated to dollars on basis of par value.

TABLE 297.—Prices of wheat, by countries, 1913-1918.

Country and market.	1913	1914	1915	1916	1917	1918
United States: Chicago.....	0.91	1.04	1.34	1.42	2.32	2.24
England: Manchester and London.....	.93	1.01	1.54	1.69	2.23	2.15
France: Paris.....	1.46	1.44	1.59	1.52	1.99	.....
Italy: Milan.....	1.49	1.50	2.16	1.97	2.29	2.85
Russia: Saratoo.....	.71	.74	1.08	.....	.....	.....
Japan: Yokohama.....	1.13	1.08	1.11	1.10	1.35	.....
India: Calcutta.....	.....	1.18	1.22	1.05	1.12	.....
Australia: Brisbane.....	.87	.96	1.80	1.33	.90	.....
Germany: Berlin.....	1.29	1.43	1.75	.....	.....	.....
Argentina: Buenos Aires.....	1.00	1.05	1.33	1.12	1.85	.....



PRODUCTIVITY OF VARIOUS COUNTRIES.

Index figures are usually applied to price comparisons, but they can as readily be used to compare the relative productivity of different countries. Six crops—wheat, oats, rye, barley, corn, and potatoes—comprise the bulk of crop production in most countries of the world. Of the total area in cultivated crops, (before the war), excluding hay and grass crops, they comprised in Germany approximately 82 per cent; in France, 75 per cent; United Kingdom, 72; Denmark, 79; Holland, 70; Belgium, 75; Austria, 84; Hungary, 87; Italy, 45; Spain, 65; Roumania, 92; European Russia, 87; Asiatic Russia, 91; Bulgaria, 85; Algeria, 85; Japan, 31; Australia, 91; Canada, 91; Argentina, 88; United States, 82 per cent. Although these figures are only approximations, they are sufficiently accurate to indicate that index numbers of the relative yields per acre of these six products combined would fairly represent the relative per acre productivity of the various countries. For each country the average yield per acre for a series of years was obtained (except in a few countries where data for only one or two years were obtainable), and these average yields were reduced to their percentage of the average yield of all countries. The percentages for each country were combined, weighted in proportion to the relative acreage of the various crops in the country, to obtain the index number of production. Following is the result obtained, 100 representing the weighted average of all countries:

TABLE 298.—Index numbers of productivity of countries named.

Belgium.....	221	Sweden.....	136	Australia.....	76
Switzerland.....	202	Norway.....	128	Serbia.....	76
Netherlands.....	190	France.....	123	Argentina.....	75
United Kingdom.....	177	Austria.....	120	Portugal.....	73
Germany.....	169	Hungary.....	113	Russia, European.....	72
Denmark.....	168	United States.....	108	Russia, Asiatic.....	71
New Zealand.....	167	Italy.....	96	Uruguay.....	70
Egypt.....	161	Roumania.....	94	Algeria.....	65
Japan.....	137	Spain.....	93	Mexico.....	52
Canada.....	136	Bulgaria.....	87	Tunis.....	37
Chile.....	136	India.....	84		

WORLD PRODUCTION AND EXPORT TRADE.

TABLE 299.—Production and export trade of the world in important crops, average, 1909-1913, in millions, i. e., 000,000 omitted.

[Substantially the total production and exports for the world. However, China's probably large cotton production, also some minor items of production and exports for other countries, are omitted owing to lack of trustworthy information. One short ton = 2,000 pounds.]

Crop.	Production.		Exports.			
	World.	United States production.	World.	Contributed by United States.	World crop exported.	United States crop exported.
		<i>Per cent.</i>		<i>Per cent.</i>	<i>Per cent.</i>	<i>Per cent.</i>
Wheat..... bushels..	3,726	18	745	13	20	15
Corn..... do.....	3,807	71	745	17	7	2
Oats..... do.....	4,324	26	<sup>1</sup> 234	<sup>1</sup> 5	<sup>1</sup> 5	<sup>1</sup> 1
Barley..... do.....	1,468	12	<sup>1</sup> 300	<sup>1</sup> 3	<sup>1</sup> 20	<sup>1</sup> 4
Rye..... do.....	1,788	2	<sup>1</sup> 108	<sup>1</sup> 0.8	<sup>1</sup> 6	<sup>1</sup> 2
Potatoes..... do.....	5,471	6	<sup>1</sup> 75	<sup>1</sup> 2	<sup>1</sup> 1	<sup>1</sup> 0.5
Tobacco..... pounds..	2,712	37	929	41	34	38
Rice..... do.....	110,780	0.6	12,721	0.1	11	2
Cotton..... 500-pound bales..	21.1	62	14.0	64	66	69
Sugar..... short tons..	18.7	5	7.5	0.5	40	4

<sup>1</sup> Three-year average, 1911-1913.

## FOREIGN TRADE IN FOODSTUFFS.

TABLE 300.—Values of exports and imports of foodstuffs, in millions of dollars, 1913-1919.

Item.	Year ending Dec. 31—						
	1919	1918	1917	1916	1915	1914	1913
Exports of domestic foodstuffs:							
In crude condition, and food animals.....	678	547	509	421	462	275	170
Partly or wholly manufactured.....	1,963	1,406	807	648	551	309	325
Total.....	2,641	1,953	1,316	1,069	1,013	584	495
Imports of foodstuffs:							
In crude condition, and food animals.....	545	346	386	260	243	235	221
Partly or wholly manufactured.....	556	397	351	339	273	256	198
Total.....	1,101	743	737	599	516	491	419
Net exports.....	1,540	1,211	579	470	497	93	76

## INDEX NUMBERS.

TABLE 301.—Index numbers of crop prices, monthly and average, 1910-1919.

The trend of prices to farmers for important crops is indicated in the following figures; the base 100 is the average price December 1 in the 43 years 1866-1908 of wheat, corn, oats, barley, rye, buckwheat, potatoes, hay, flax, and cotton.

Date.	1919	1918	1917	1916	1915	1914	1913	1912	1911	1910	Average.
Jan. 1.....	272.4	264.1	183.6	129.0	126.7	132.5	110.9	133.9	118.6	134.1	160.6
Feb. 1.....	259.9	271.6	195.6	139.9	140.5	132.1	112.6	140.2	119.8	138.5	165.1
Mar. 1.....	257.1	288.8	206.5	138.6	144.0	133.8	113.3	144.7	117.9	139.9	168.5
Apr. 1.....	271.2	288.6	225.2	140.2	144.5	134.2	113.6	153.4	118.0	138.8	172.8
May 1.....	293.7	281.8	280.6	143.3	150.0	135.9	116.2	166.3	122.2	133.5	182.4
June 1.....	307.2	271.9	291.3	145.8	147.3	138.8	121.2	168.3	127.7	133.5	185.3
July 1.....	310.2	272.9	289.9	144.8	139.1	137.7	122.9	160.1	136.3	133.1	184.7
Aug. 1.....	329.0	280.6	307.8	147.7	138.9	137.6	125.4	148.0	148.2	137.1	190.0
Sept. 1.....	317.7	293.3	279.6	161.5	132.5	141.3	136.3	137.6	141.6	137.0	187.8
Oct. 1.....	290.0	289.3	277.0	163.6	128.2	136.4	139.1	128.6	138.0	129.8	182.0
Nov. 1.....	279.4	269.5	261.3	178.8	124.4	127.4	133.9	118.3	135.6	122.2	175.1
Dec. 1.....	283.8	265.2	252.3	187.0	120.4	122.8	132.7	110.3	133.1	118.4	172.7
Average <sup>1</sup> .....	290.0	277.7	259.5	162.1	132.1	132.4	128.1	132.8	132.8	129.5	177.7

<sup>1</sup> Weighted average.

## PRICES OF ARTICLES BOUGHT BY FARMERS.

TABLE 302.—Prices of articles bought by farmers, 1909-1919, and amount purchasable with an acre of crop production.

Item.	1919	1918	1914	1909	1919 per cent of—			Amount purchasable with average value of 1 acre of crop production.		
					1918	1914	1909	1919	1914	1909
Axes.....each	\$2.06	\$1.79	\$0.96	\$0.89	115	215	231	18	18	19
Barb wire.....100 lbs	5.73	5.69	3.08	2.98	101	186	188	6.4	5.6	5.6
Barrels.....each	.47	.45	.25	.....	104	188	.....	79	62	.....
Bone meal.....ton	59.00	55.10	31.90	.....	107	185	.....	.63	.54	.....
Brooms.....each	1.00	.98	.38	.34	102	263	294	37	46	49
Buggies.....do	122.00	107.00	70.10	64.90	114	174	188	.30	.25	.26
Buggy whips.....do	.72	.67	.426	.404	107	169	178	51	41	41
Calico.....yard	.226	.207	.063	.06	109	359	377	163	275	277
Carbolic acid.....lb	.369	.360	.....	.....	102	.....	.....	100	.....	.....
Churns.....each	2.94	2.62	2.30	2.19	112	128	134	13	7.5	7.6

PRICES OF ARTICLES BOUGHT BY FARMERS—Continued.

TABLE 302.—Prices of articles bought by farmers, 1909–1919, and amount purchasable with an acre of crop production—Continued.

Item.	1919	1918	1914	1909	1919 per cent of—			Amount purchasable with average value of 1 acre of crop production.		
					1918	1914	1909	1919	1914	1909
Coal.....ton	\$9.00	\$8.11	\$5.80	\$5.50	111	155	164	4.1	3.0	3.0
Coal oil.....gall	.216	.184	.139	.157	117	155	138	171	125	106
Coffee.....lb	.467	.310	.245	.211	151	191	221	79	71	79
Copperas.....do	.129	.124			104			286		
Corn knives.....each	.58	.52	.29	.27	112	200	215	64	60	62
Cream separators.....do	95.00	87.00	59.30	63.10	109	160	151	.39	.29	.26
Dinner plates.....½ doz	1.36	1.18	.57	.55	115	239	247	27	30	30
Dish pans, tin.....do	.84	.74	.34	.32	114	247	262	44	51	52
Dung forks.....do	1.40	1.23	.76	.70	114	184	200	26	23	24
Fertilizer, commercial.....ton	42.35	38.80	23.20	22.15	109	183	191	.87	.75	.75
Flour.....bbl	13.41	12.45	6.40	6.30	108	210	213	2.8	2.7	2.6
Fruit jars.....doz	1.15	1.06	.74	.73	108	155	158	32	23	23
Gasoline.....gall	.283	.278	.179	.202	102	158	140	130	97	82
Gloves, cotton.....pair	.262	.238			110			141		
Gloves, leather.....do	1.79	1.51			119			21		
Grindstones.....lb	.048	.045			107			769		
Halters.....each	1.88	1.62	.95	.85	116	198	221	20	18	20
Harness, single.....do	28.60	24.10	15.25	13.50	119	188	212	1.3	1.1	1.2
Hatchets.....do	1.29	1.09	.62	.59	118	208	219	29	28	28
Hats, felt.....do	4.27	3.35	2.03	1.94	127	210	220	8.6	8.5	8.6
Hoes.....do	.85	.75	.45	.41	113	189	207	43	38	41
Horse blankets.....do	5.10	4.33	2.40	2.25	118	212	227	7.2	7.2	7.4
Jumpers.....do	2.46	2.20	.83	.77	112	296	319	15	21	22
Kitchen chairs.....do	1.65	1.42	.80	.72	116	206	229	22	22	23
Lamps.....do	.98	.86	.52	.50	114	188	196	38	30	30
Lanterns.....do	1.33	1.20	.80	.77	111	166	173	28	22	22
Lard.....lb	.347	.323	.141	.132	107	246	263	106	123	126
Lime.....bbl	2.64	2.30	1.36	1.29	115	194	205	14	13	13
Linseed oil.....gall	2.54	2.08	.82	.79	122	310	322	15	21	21
Lumber, 1-inch.....100 ft	4.57	3.50	2.10	1.95	131	218	234	8.1	8.2	8.5
Manure spreaders.....each	179.70	169.40	106.70	111.60	106	168	161	.21	.16	.15
Men's suits.....do	38.10	27.60	14.00	13.15	138	272	290	.97	1.2	1.5
Milk cans, 10-gallon.....do	6.04	5.50	2.45	2.40	110	247	252	6.1	7.1	6.9
Milk pails.....do	.88	.79	.45	.43	111	196	205	42	38	39
Mowers.....do	84.50	79.20	46.50	44.30	107	182	191	.44	.37	.38
Muslin.....yard	.31	.272	.093	.09	114	333	344	119	186	185
Nails.....100 lbs	6.25	5.97	3.40	3.34	105	184	187	5.9	5.1	5.0
Overalls.....pair	2.55	2.26	.89	.82	113	287	311	14	19	20
Padlocks.....each	.49	.44	.275	.27	111	178	181	75	63	62
Paint brushes.....do	1.14	.97	.54	.49	118	211	233	32	32	34
Paint, mixed.....gall	4.07	3.40	1.74	1.62	120	234	251	9.1	9.9	10.0
Paris green.....lb	.62	.62	.30	.29	100	207	214	60	58	57
Picks.....each	1.42	1.22	.72	.71	116	197	200	26	24	23
Pincers.....do	.93	.87	.51	.49	107	182	190	40	34	34
Pitchforks.....do	1.30	1.14	.66	.62	114	197	210	28	26	27
Plows.....do	21.00	20.00	12.10	11.50	105	174	183	1.8	1.4	1.4
Portland cement.....100 lbs	1.01	.96	.69	.70	105	146	144	37	25	24
Raincoats.....each	9.16	7.73	4.40	4.25	118	208	216	4.0	3.9	3.9
Rope, hemp.....lb	.368	.349	.149	.135	105	247	273	100	116	123
Rubber boots.....pair	5.10	5.00	3.75	3.55	102	136	144	7.2	4.6	4.7
Sacks, grain.....each	.46	.43	.163	.15	107	282	307	80	106	111
Saddles.....do	42.40	35.80	20.35	17.45	118	208	243	.87	.85	.95
Salt, for stock.....bbl	3.01	2.71	1.65	1.50	111	182	201	12.3	10.0	11.0
Saws, buck.....each	1.77	1.54	.92	.89	115	192	199	21	19	19
Scythes.....do	1.82	1.60	1.06	1.02	114	172	178	20	16	16
Sheeting.....yard	.57	.48	.18	.17	119	317	335	65	96	98
Shingles.....1,000	7.96	5.65	3.70	3.50	141	215	227	4.6	4.7	4.8
Shirts, flannel.....each	3.81	3.13	1.41	1.34	122	270	284	9.7	12	12
Shoes.....pair	4.73	3.81	2.30	2.00	124	206	236	7.8	7.5	8.3
Shotguns.....each	27.70	23.70	12.85	12.45	117	216	222	1.3	1.3	1.3

## PRICES OF ARTICLES BOUGHT BY FARMERS—Continued.

TABLE 302.—Prices of articles bought by farmers, 1909–1919, and amount purchasable with an acre of crop production—Continued.

Item.	1919	1918	1914	1909	1919 per cent of—			Amount purchasable with average value of 1 acre of crop production.		
					1918	1914	1909	1919	1914	1909
					Shovels.....do.....	\$1.62	\$1.42	\$0.78	\$0.74	114
Staples.....100 lbs..	6.78	6.41	3.75	3.69	106	181	184	5.4	4.6	4.5
Starch.....lb.....	.118	.105	.07	.07	112	169	169	313	247	241
Steel wire.....100 lbs.	6.82	6.45	3.55	3.43	106	192	199	5.4	4.9	4.8
Stoves.....each.....	47.20	44.00	24.00	22.50	107	197	210	.78	.72	.74
Sugar.....lb.....	.158	.115	.069	.058	137	229	272	234	251	287
Sulphur.....do.....	.119	.116	.08	.075	103	149	159	310	216	222
Tenders.....each.....	74.30	69.40	39.50	39.00	107	188	191	.50	.44	.43
Tin pails.....do.....	.59	.53	.27	.25	111	219	236	63	64	67
Tobacco, plug.....lb..	.93	.75	.45	.45	124	207	207	40	38	37
Twine, binder.....do..	.258	.265	.112	.103	97	230	250	143	155	162
Wagons, double.....each.	138.00	120.00	73.25	66.00	115	188	209	.27	.24	.25
Wagons, single.....do..	82.50	75.00	48.00	45.50	110	172	181	.45	.36	.37
Walking cultivators.....do.	35.20	32.90			107			1.0		
Wheelbarrows.....do....	5.45	4.75	2.97	2.80	115	184	195	6.8	5.8	5.9
Wire fence.....rod.....	.59	.57	.317	.311	104	186	190	63	55	54
Wooden buckets.....each..	.99	.85	.35	.31	116	283	319	37	49	54
Wooden washtubs.....do....	1.73	1.56	.83	.77	111	208	225	21	21	22

## FARM LABOR.

TABLE 303.—Wages of male farm labor by classes and States, 1910 and 1919.

State and division.	Per month.				Per day at harvest.				Per day other than harvest.			
	With board.		Without board.		With board.		Without board.		With board.		Without board.	
	1919	1910	1919	1910	1919	1910	1919	1910	1919	1910	1919	1910
Maine.....	\$49.40	\$23.50	\$70.00	\$34.50	\$3.10	\$1.50	\$3.85	\$1.95	\$2.70	\$1.23	\$3.43	\$1.60
New Hampshire.....	44.90	23.50	69.70	35.50	2.95	1.35	3.80	1.84	2.50	1.18	3.37	1.65
Vermont.....	45.00	25.00	65.00	35.50	3.00	1.75	3.82	2.25	2.60	1.21	3.15	1.60
Massachusetts.....	45.00	22.75	71.00	37.20	2.93	1.42	3.75	1.92	2.60	1.22	3.40	1.66
Rhode Island.....	48.00	21.00	73.00	34.00	2.60	1.35	3.50	2.05	2.40	1.12	3.20	1.56
Connecticut.....	45.00	21.00	71.00	36.00	2.89	1.55	3.75	2.00	2.60	1.07	3.36	1.55
New York.....	43.30	23.50	62.50	35.00	3.30	1.80	4.02	2.22	2.70	1.28	3.38	1.66
New Jersey.....	44.00	19.50	67.00	31.50	3.20	1.70	4.10	2.15	2.58	1.11	3.32	1.46
Pennsylvania.....	37.80	18.75	59.00	29.00	2.95	1.50	3.71	1.96	2.45	1.04	3.20	1.49
N. Atlantic.....	42.18	21.65	63.39	33.19	3.09	1.63	3.86	2.08	2.59	1.17	3.30	1.58
Delaware.....	34.00	16.00	50.50	24.75	3.50	1.35	4.00	1.55	2.50	.98	3.20	1.22
Maryland.....	32.00	13.50	49.00	21.50	3.05	1.26	3.71	1.64	2.25	.88	2.96	1.18
Virginia.....	31.00	14.00	45.00	19.50	2.51	1.15	3.10	1.44	1.85	.78	2.42	1.01
West Virginia.....	40.00	19.40	58.00	29.00	2.71	1.28	3.40	1.65	2.15	.94	2.82	1.27
North Carolina.....	32.40	13.60	45.00	19.50	2.41	1.03	3.01	1.28	2.00	.73	2.50	.97
South Carolina.....	27.00	12.00	38.40	16.50	1.94	.96	2.40	1.12	1.60	.70	2.10	.90
Georgia.....	26.70	13.00	38.50	18.00	1.90	.98	2.30	1.23	1.67	.73	2.15	.95
Florida.....	28.00	15.00	45.00	25.00	1.72	1.10	2.30	1.46	1.62	.96	2.22	1.32
S. Atlantic.....	30.54	13.77	44.03	19.75	2.28	1.07	2.82	1.33	1.85	.77	2.39	1.01
Ohio.....	39.40	21.00	56.20	29.00	3.47	1.67	4.22	2.07	2.66	1.20	3.38	1.57
Indiana.....	38.15	20.50	53.30	28.40	3.50	1.70	4.30	2.07	2.53	1.14	3.21	1.45
Illinois.....	43.50	24.50	58.50	32.90	3.88	1.90	4.63	2.30	2.72	1.31	3.42	1.63
Michigan.....	42.00	23.00	60.00	33.00	3.50	1.64	4.30	2.10	2.80	1.22	3.60	1.66
Wisconsin.....	48.70	26.00	69.00	37.25	3.30	1.76	4.02	2.20	2.90	1.35	3.63	1.78
N. C. E. Miss. R.....	42.12	22.94	58.90	31.81	3.56	1.75	4.32	2.16	2.71	1.24	3.44	1.61

FARM LABOR—Continued.

TABLE 303.—Wages of male farm labor by classes and States, 1910 and 1919—Continued.

State and division.	Per month.				Per day at harvest.				Per day other than harvest.			
	With board.		Without board.		With board.		Without board.		With board.		Without board.	
	1919	1910	1919	1910	1919	1910	1919	1910	1919	1910	1919	1910
Minnesota.....	\$53.70	\$26.00	\$75.00	\$38.00	\$4.30	\$2.23	\$5.15	\$2.65	\$3.32	\$1.48	\$4.25	\$1.90
Iowa.....	55.00	28.00	71.43	39.00	4.46	2.12	5.20	2.51	3.46	1.57	4.24	1.98
Missouri.....	37.00	21.50	50.90	29.50	3.45	1.55	4.35	1.93	2.15	1.02	2.75	1.32
North Dakota.....	56.00	29.00	79.30	42.00	4.85	2.40	5.85	3.03	3.50	1.60	4.50	2.20
South Dakota.....	65.00	27.00	88.00	39.00	4.95	2.35	6.00	2.95	3.90	1.54	5.00	2.00
Nebraska.....	56.80	26.50	77.50	38.00	5.25	2.14	6.25	2.60	3.85	1.57	4.75	1.96
Kansas.....	49.50	24.00	65.50	34.00	5.42	2.18	6.05	2.57	3.71	1.42	4.47	1.84
N. C. W. Miss. R.....	50.29	25.10	68.10	35.45	4.48	2.01	5.33	2.43	3.22	1.38	4.03	1.77
Kentucky.....	33.00	16.00	46.00	23.10	2.70	1.36	3.35	1.71	1.84	.85	2.34	1.12
Tennessee.....	29.00	14.00	41.40	20.00	2.20	1.14	2.70	1.44	1.63	.77	2.12	1.02
Alabama.....	25.50	13.00	36.50	18.50	1.80	.98	2.30	1.26	1.65	.85	2.10	1.05
Mississippi.....	26.50	13.30	38.00	19.50	1.77	.93	2.30	1.22	1.81	.83	2.32	1.10
Louisiana.....	30.20	13.50	43.10	20.25	2.10	.90	2.56	1.25	2.00	.77	2.42	1.02
Texas.....	38.80	18.00	55.20	24.50	3.10	1.22	3.68	1.57	2.50	1.04	3.15	1.32
Oklahoma.....	40.50	19.10	60.60	28.10	4.00	1.60	4.80	1.97	2.95	1.11	3.68	1.47
Arkansas.....	31.70	16.25	45.60	24.00	2.50	1.20	3.10	1.55	1.90	.90	2.45	1.20
S. Central.....	32.42	15.28	46.47	21.90	2.56	1.14	3.14	1.47	2.06	.89	2.61	1.15
Montana.....	62.20	38.00	89.00	50.00	4.00	2.05	4.95	2.80	3.25	1.77	4.35	2.36
Wyoming.....	60.50	35.00	86.10	49.00	3.65	1.90	4.70	2.50	3.13	1.73	4.25	2.29
Colorado.....	55.50	29.50	81.00	44.50	3.60	1.95	4.60	2.47	3.00	1.47	3.95	2.00
New Mexico.....	40.50	24.50	59.20	34.25	2.50	1.46	3.20	1.88	2.20	1.12	2.80	1.58
Arizona.....	60.00	30.00	83.00	40.00	2.90	1.72	3.65	2.24	2.60	1.34	3.30	2.04
Utah.....	70.00	35.00	92.00	47.50	3.40	1.78	4.10	2.20	3.10	1.55	3.90	2.00
Nevada.....	68.00	37.00	93.00	54.00	3.65	1.82	4.45	2.38	2.85	1.39	3.90	1.96
Idaho.....	69.00	35.00	93.60	49.50	4.00	2.20	4.95	2.80	3.45	1.70	4.50	2.27
Washington.....	66.30	33.00	91.00	50.00	4.50	2.42	5.40	2.78	3.55	1.72	4.60	2.26
Oregon.....	64.00	32.00	87.00	44.50	4.00	2.12	4.85	2.60	3.10	1.51	4.10	2.07
California.....	66.30	33.00	91.20	47.00	3.84	1.98	4.69	2.48	2.99	1.44	3.90	2.02
Far Western.....	62.96	32.69	87.12	46.48	3.80	2.02	4.67	2.52	3.08	1.51	4.02	2.06
United States.....	39.82	19.21	56.29	27.50	3.15	1.45	3.83	1.82	2.45	1.06	3.12	1.83

TABLE 304.—Wages of classes of male farm labor, yearly, in United States, 1866-1919.

Year.	By the month.		Day labor at harvest.		Day labor not harvest.	
	With board.	Without board.	With board.	Without board.	With board.	Without board.
1919.....	\$39.82	\$56.29	\$3.15	\$3.83	\$2.45	\$3.12
1918.....	34.92	48.80	2.65	3.22	2.07	2.63
1917.....	28.87	40.43	2.08	2.54	1.56	2.02
1916.....	23.25	32.83	1.69	2.07	1.26	1.62
1915.....	21.26	30.15	1.56	1.92	1.13	1.47
1914.....	21.05	29.88	1.55	1.91	1.13	1.45
1913.....	21.38	30.31	1.57	1.94	1.16	1.50
1912.....	20.81	29.58	1.54	1.87	1.14	1.47
1911.....	20.18	28.77	1.49	1.85	1.09	1.42
1910.....	19.21	27.50	1.45	1.82	1.06	1.38
1902.....	16.40	22.14	1.34	1.53	.89	1.13
1899.....	14.07	20.23	1.12	1.37	.77	1.01
1898.....	13.43	19.38	1.05	1.30	.72	.96
1895.....	12.02	17.69	.92	1.14	.62	.81
1894.....	12.16	17.74	.93	1.13	.63	.81
1893.....	13.29	19.10	1.03	1.24	.69	.80
1892.....	12.54	18.60	1.02	1.30	.67	.92
1890.....	12.45	18.33	1.02	1.30	.68	.92
1888.....	12.36	18.24	1.02	1.31	.67	.92
1885.....	12.34	17.97	1.10	1.40	.67	.91
1882.....	12.41	18.94	1.15	1.48	.67	.93
1879.....	10.43	16.42	1.00	1.30	.59	.81
1875.....	12.72	19.87	1.35	1.70	.78	1.08
1869.....	16.55	25.92	1.74	2.20	1.02	1.41
1866.....	17.45	26.87	1.74	2.20	1.08	1.49

## HOW FARM LABOR IS HIRED.

Of the total labor hired on farms of the United States, the percentage which is hired by the month, by the day, with board and without board, is estimated as follows, based upon reports of crop reporters of the Bureau of Crop Estimates:

TABLE 305.—Percentage of total hired labor, by divisions.

Item.	United States.	North Atlantic. <sup>1</sup>	North Central, east. <sup>2</sup>	North Central, west. <sup>3</sup>	South Atlantic. <sup>4</sup>	South Central. <sup>5</sup>	West. <sup>6</sup>
Hired by the—							
Month—	<i>Per cent.</i>	<i>Per cent.</i>	<i>Per cent.</i>	<i>Per cent.</i>	<i>Per cent.</i>	<i>Per cent.</i>	<i>Per cent.</i>
With board.....	36.1	39.3	44.8	52.7	33.7	29.0	37.4
Without board.....	15.5	16.5	15.1	9.4	17.2	17.0	9.5
Day, excluding extra harvest—							
With board.....	15.3	14.2	15.5	13.8	17.4	14.8	13.7
Without board.....	15.7	13.7	9.2	4.8	16.6	21.0	14.9
Day, harvest labor—							
With board.....	10.5	9.0	10.8	15.9	8.3	9.7	16.9
Without board.....	6.9	7.3	4.6	3.4	6.8	8.5	7.6
	100.0	100.0	100.0	100.0	100.0	100.0	100.0
Hired with board.....	61.9	62.5	71.1	82.4	59.4	53.5	68.0
Hired without board.....	38.1	37.5	28.9	17.6	40.6	46.5	32.0

<sup>1</sup> Maine, New Hampshire, Vermont, Massachusetts, Rhode Island, Connecticut, New York, New Jersey, Pennsylvania.

<sup>2</sup> Ohio, Indiana, Illinois, Michigan, Wisconsin.

<sup>3</sup> Minnesota, Iowa, Missouri, North Dakota, South Dakota, Nebraska, Kansas.

<sup>4</sup> Delaware, Maryland, Virginia, West Virginia, North Carolina, South Carolina, Georgia, Florida.

<sup>5</sup> Kentucky, Tennessee, Alabama, Mississippi, Louisiana, Texas, Oklahoma, Arkansas.

<sup>6</sup> Montana, Wyoming, Colorado, New Mexico, Arizona, Utah, Nevada, Idaho, Washington, Oregon, California.

## FARM AND LABOR INCOME.

TABLE 306.—Average farm income and labor income on farms in the various areas studied by the Office of Farm Management.

Farm income: The difference between receipts and expenses. It represents the amount of money available for the farmer's living above the value of family labor, provided he has no interest to pay on mortgages or other debts.

Labor income: The amount that the farmer has left for his labor after 5 per cent interest on the farm investment is deducted from the farm income. It represents what he earned as a result of his year's labor after the earning power of his investment has been deducted. In addition to the labor income the farmer received a house to live in, fuel (when cut from the farm), garden products, milk, butter, eggs, etc.

Areas.	Year.	Number of farms.	Average farm income.	Average labor income.
Cass and Menard Counties, Ill.....	1910	73	\$3,176	\$622
Guthrie and Green Counties, Iowa.....	1910	77	1,450	291
Chester County, Pa.....	1911	378	1,313	789
Lenawee County, Mich.....	1911	300	1,068	481
Muck-land farms of northern Indiana and southern Michigan.....	1914	100	1,917	1,072
Cut-overlands of Michigan, Wisconsin, and Minnesota.....	1914	801	391	49
Barry and Lawrence Counties, Mo.....	1914	244	822	370
Anderson County, S. C.....	1914	112	557	110
Brooks County, Ga.....	1914	106	952	502
New England:				
Southern New England.....	1914	719	837	392
Northern New England.....	1914	441	864	436
Southern Maine.....	1914	415	491	202
Frederick County, Md.....	1915	150	1,380	368
Mercer County, Pa.....	1916	349	668	285
Small farms around Washington, D. C.....	1916	152	700	408
Irrigated farms in southern Arizona.....	1913-1915	446	2,370	713
Utah Lake Valley, Utah.....	1913	69	867	417
Do.....	1914	75	1,312	728
Sumter County, Ga.....	1913	268	1,662	471
Do. <sup>1</sup> .....	1918	280	3,710	1,817
Washington County, Ohio (average of 7 years) <sup>2</sup> .....	1912-1913	175	606	272
Clinton County, Ind. (average of 7 years).....	1910, 1913-1918	700	1,824	533
Dane County, Wis. (average of 5 years) <sup>2</sup> .....	1913-1917	300	1,293	408
Gloucester County, N. J. (average of 3 years).....	1914-1916	375	1,536	1,013
Polk County, Fla. (average of 2 years) <sup>2</sup> .....	1917-1918	105	1,916	843
Hillsboro County, Fla. (average of 2 years) <sup>2</sup> .....	1917-1918	232	849	562
Frederick County, Va. (average of 2 years) <sup>2</sup> .....	1916-1917	302	2,776	1,478
Salt Lake Valley, Utah.....	1915	428	778	162
Total.....		8,172		

<sup>1</sup> Same area repeated after a lapse of 5 years.

<sup>2</sup> Surveys being continued over a period of years.

## VALUE OF PLOW LANDS.

TABLE 307.—Value of plow lands, by States, 1917-1920.

State.	Average of poor plow lands.			Average of good plow lands.			Average of all plow lands.			
	1920	1919	1918	1920	1919	1918	1920	1919	1918	1917
Maine.....	\$30.00	\$24.00	\$24.00	\$56.00	\$50.00	\$48.00	\$42.00	\$37.00	\$35.00	\$34.00
New Hampshire.....	24.00	23.00	21.00	64.00	54.00	52.00	42.00	39.00	39.00	37.00
Vermont.....	30.00	30.00	28.00	69.00	64.00	64.00	48.00	44.00	44.00	42.00
Massachusetts.....	40.00	41.00	41.00	103.00	92.00	92.00	72.00	68.00	68.00	64.00
Rhode Island.....	50.00	47.00	46.00	105.00	92.00	90.00	85.00	73.00	70.00	62.00
Connecticut.....	35.00	37.00	37.00	100.00	80.00	75.00	60.00	55.00	52.00	53.00
New York.....	39.00	38.00	33.00	84.00	80.00	75.00	64.00	60.00	58.00	55.00
New Jersey.....	50.00	50.00	58.00	104.00	103.00	108.00	80.00	76.00	78.00	69.00
Pennsylvania.....	40.00	38.00	37.00	86.00	79.00	79.00	66.00	60.00	58.00	57.00
Delaware.....	44.00	36.00	35.00	86.00	70.00	68.00	66.00	55.00	59.00	55.00
Maryland.....	46.00	39.00	33.00	82.00	66.00	61.00	60.00	53.00	47.00	48.00
Virginia.....	34.00	31.00	29.00	73.00	62.00	61.00	53.00	47.00	43.00	36.50
West Virginia.....	32.00	29.00	28.00	75.00	64.00	64.00	51.00	44.00	43.00	38.50
North Carolina.....	42.00	31.00	29.00	87.00	67.00	58.00	63.00	50.00	42.00	35.00
South Carolina.....	41.00	27.00	23.00	82.00	56.00	45.00	61.00	45.00	36.00	33.00
Georgia.....	30.00	24.50	20.00	63.00	49.30	40.00	46.00	37.50	28.00	27.50
Florida.....	23.00	21.00	21.00	53.00	48.00	42.00	36.00	33.00	32.00	27.50
Ohio.....	69.00	63.00	61.00	132.00	113.00	107.00	105.00	91.00	86.00	80.00
Indiana.....	80.00	68.00	67.00	150.00	126.00	120.00	119.00	100.00	96.00	87.00
Illinois.....	115.00	100.00	94.00	213.00	170.00	160.00	170.00	144.00	132.00	120.00
Michigan.....	41.00	40.00	38.00	80.00	76.00	75.00	64.00	61.00	60.00	55.00
Wisconsin.....	66.00	60.00	56.00	125.00	110.00	100.00	100.00	89.00	82.00	80.00
Minnesota.....	73.00	59.00	54.00	120.00	88.00	85.00	100.00	78.00	75.00	68.00
Iowa.....	157.00	129.00	119.00	257.00	196.00	180.00	219.00	169.00	154.00	140.00
Missouri.....	60.00	51.00	47.00	110.00	91.00	83.00	87.00	72.00	66.00	60.00
North Dakota.....	31.00	27.50	26.00	49.00	43.00	41.00	43.00	37.00	35.00	33.00
South Dakota.....	67.00	50.00	41.00	108.00	77.00	63.00	90.00	67.00	56.00	54.00
Nebraska.....	85.00	67.00	60.00	150.00	115.00	100.00	125.00	95.00	80.00	74.00
Kansas.....	50.00	44.00	42.00	90.00	77.00	74.00	70.00	61.00	58.00	53.00
Kentucky.....	42.00	37.00	31.00	95.00	80.00	65.00	70.00	61.00	50.00	41.00
Tennessee.....	40.00	31.00	30.00	90.00	75.00	67.00	60.00	53.00	48.00	41.00
Alabama.....	20.00	17.00	15.00	43.00	33.00	30.00	30.00	24.00	21.00	17.00
Mississippi.....	23.00	16.00	15.00	49.00	33.50	31.00	35.00	25.50	23.00	20.00
Louisiana.....	34.00	25.00	26.00	65.00	44.00	45.00	50.00	33.00	33.00	25.00
Texas.....	36.00	27.00	30.00	72.00	58.00	57.00	56.00	46.00	45.00	38.00
Oklahoma.....	30.00	24.00	23.00	63.00	51.00	48.00	47.00	38.00	35.00	30.00
Arkansas.....	26.00	22.00	20.00	65.00	50.00	45.00	45.00	38.00	31.00	27.00
Montana.....	21.00	21.00	22.00	48.00	45.00	45.00	36.00	34.00	35.00	31.50
Wyoming.....	34.00	26.00	25.00	70.00	53.00	49.00	53.00	43.00	41.00	30.00
Colorado.....	40.00	36.00	35.00	88.00	80.00	74.00	66.00	60.00	55.00	55.00
New Mexico.....	30.00	30.00	25.00	60.00	60.00	60.00	45.00	45.00	42.00	36.00
Arizona.....	90.00	60.00	52.00	180.00	125.00	116.00	130.00	100.00	98.00	85.00
Utah.....	60.00	55.00	48.00	135.00	125.00	113.00	103.00	95.00	86.00	70.00
Nevada.....	46.00	50.00	42.00	110.00	110.00	110.00	80.00	85.00	80.00	60.00
Idaho.....	60.00	50.00	43.00	135.00	98.00	89.00	105.00	76.00	70.00	58.00
Washington.....	68.00	60.00	56.00	150.00	121.00	122.00	115.00	95.00	94.00	80.00
Oregon.....	60.00	53.00	53.00	130.00	108.00	111.00	100.00	81.00	84.00	70.00
California.....	70.00	69.00	66.00	175.00	165.00	168.00	130.00	121.00	120.00	110.00
United States.....	60.76	51.26	47.86	113.34	91.83	85.48	90.01	74.31	68.38	62.17

## INDEX NUMBERS.

TABLE 308.—Index numbers of prices of meat animals, monthly and average, 1910-1919.

Date.	1919	1918	1917	1916	1915	1914	1913	1912	1911	1910	Average.
Jan. 15.....	13.46	12.59	8.53	6.46	6.57	7.05	6.40	5.44	6.40	6.68	7.96
Feb. 15.....	13.51	12.65	9.42	6.94	6.46	7.27	6.70	5.54	6.19	6.71	8.14
Mar. 15.....	14.06	13.06	10.70	7.53	6.46	7.37	7.08	5.69	6.09	7.39	8.54
Apr. 15.....	15.01	13.55	11.71	7.85	6.59	7.40	7.35	6.30	5.80	7.74	8.93
May 15.....	15.34	13.83	11.84	7.98	6.80	7.29	7.08	6.39	5.54	7.37	8.95
June 15.....	14.98	13.62	11.72	8.00	6.85	7.22	7.19	6.27	5.45	7.29	8.86
July 15.....	15.61	13.68	11.47	8.04	6.83	7.41	7.25	6.23	5.52	6.98	8.90
Aug. 15.....	15.56	14.21	11.84	8.05	6.74	7.63	7.20	6.56	5.87	6.67	9.03
Sept. 15.....	13.44	14.50	12.79	8.38	6.77	7.58	7.15	6.74	5.87	6.92	9.01
Oct. 15.....	12.22	13.79	13.04	8.04	6.96	7.14	7.14	6.86	5.58	6.80	8.76
Nov. 15.....	11.88	13.37	12.47	8.09	6.45	6.80	6.94	6.45	5.44	6.47	8.44
Dec. 15.....	11.54	13.40	12.74	8.15	6.25	6.61	6.85	6.42	5.37	6.21	8.35
Average <sup>1</sup> .....	13.59	13.49	11.56	7.77	6.63	7.19	7.00	6.25	5.77	6.90	8.62

<sup>1</sup> Weighted average.

## MEAT PRODUCTION, IMPORTS, EXPORTS, AND CONSUMPTION.

roduction of dressed-weight meat in calendar years estimated by the Bureau of Crop Estimates for 1900, ascertained by the Bureau of the Census for 1909, estimated by the Bureau of Animal Industry for 1914-1918; edible offal estimated by the Bureau of Crop Estimates for all years from these percentages of dressed weight: Beef, including veal, 17.78 per cent; mutton, including lamb, 5 per cent; pork, including lard, 15.66 per cent. Some of the foreign trade numbers are approximate averages, and the small numbers of meat animals in this trade are not included. Beef statistics include veal; mutton includes lamb and goat; pork includes lard.

TABLE 309.—Meat production, imports, exports, and consumption, 1900-1918.

Class of meat.	1900	1909	1914	1916	1917	1918
Production, dressed weight, and edible offal, in pounds (000 omitted):						
Beef.....	8,962,805	9,545,343	7,159,738	7,857,031	8,528,929	9,796,929
Mutton.....	616,385	646,277	776,371	665,667	508,468	558,318
Pork.....	9,286,245	9,532,453	10,141,684	12,245,809	9,773,386	13,010,577
Total.....	18,865,435	19,724,073	18,077,793	20,768,507	18,810,783	23,365,824
Trend of production since 1900 (1900=100):						
Beef.....	100.0	106.5	79.9	87.7	95.2	109.3
Mutton.....	100.0	104.9	126.0	108.0	82.5	90.6
Pork.....	100.0	102.7	109.2	131.9	105.2	140.1
Total.....	100.0	104.6	95.8	110.1	99.7	123.9
Per capita production, in pounds:						
Beef.....	117.9	105.4	72.6	77.1	82.4	93.2
Mutton.....	8.1	7.1	7.9	6.5	4.9	5.3
Pork.....	122.2	105.3	102.8	120.2	94.4	123.8
Total.....	248.2	217.8	183.3	203.8	181.8	222.3
Each class of meat as a percentage of total in production, in percentages:						
Beef.....	47.5	48.4	39.6	37.8	45.3	41.9
Mutton.....	3.3	3.3	4.3	3.2	2.7	2.4
Pork.....	49.2	48.3	56.1	59.0	52.0	55.7
Total.....	100.0	100.0	100.0	100.0	100.0	100.0
Imports, in pounds (000 omitted):						
Beef.....	2,550	4,500	258,848	40,425	27,641	30,296
Mutton.....			19,876	17,235	5,624	608
Pork.....		500	26,835	1,171	2,821	3,585
Total.....	2,500	5,000	305,559	58,831	36,086	34,489



MEAT PRODUCTION, IMPORTS, EXPORTS, AND CONSUMPTION—Con.

TABLE 309.—Meat production, imports, exports, and consumption, 1900–1918—Con.

Class of meat.	1900	1909	1914	1916	1917	1918
<b>Domestic exports, in pounds (000 omitted):</b>						
Beef.....	857,542	499,828	165,756	396,442	408,430	796,785
Mutton.....	600	1,600	3,847	5,258	2,862	1,631
Pork.....	1,602,662	1,003,223	853,816	1,468,457	1,319,309	2,263,465
Total.....	2,460,804	1,504,651	1,023,419	1,870,157	1,730,601	3,061,881
<b>Excess of domestic exports over imports, in pounds (000 omitted):</b>						
Beef.....	855,042	495,328	<sup>1</sup> 93,092	356,017	380,789	766,458
Mutton.....	600	1,600	<sup>1</sup> 16,029	<sup>1</sup> 11,977	<sup>1</sup> 2,762	1,023
Pork.....	1,602,662	1,002,723	826,981	1,467,286	1,316,488	2,259,880
Total.....	2,458,304	1,499,651	717,860	1,811,326	1,694,515	3,027,392
<b>Excess of domestic exports over imports as a percentage of production, in percentages:</b>						
Beef.....	9.5	5.2	<sup>1</sup> 1.3	4.5	4.5	7.8
Mutton.....	.1	.2	<sup>1</sup> 2.1	<sup>1</sup> 1.8	1.5	.2
Pork.....	17.3	10.5	8.2	12.0	13.5	17.4
Total.....	13.0	7.6	4.0	8.7	9.0	13.0
<b>Domestic exports of animal fats and oils, in pounds (000 omitted):</b>						
Beef.....	245,000	200,000	100,657	118,756	52,810	92,788
Pork.....	655,000	450,000	460,580	456,603	384,655	555,474
Total.....	900,000	650,000	561,237	575,359	437,465	648,262
<b>Domestic exports of animal fats and oils as a percentage of domestic exports of total meat, in percentages:</b>						
Beef.....	28.6	40.0	60.7	30.0	12.9	11.6
Pork.....	40.9	44.9	53.9	31.1	29.2	24.6
Total.....	36.6	43.2	54.8	30.8	25.3	21.2
<b>Consumption, dressed weight and edible offal, in pounds (000 omitted):</b>						
Beef.....	8,107,763	9,050,015	7,252,830	7,501,014	8,148,140	9,030,440
Mutton.....	615,785	644,677	792,400	677,644	511,230	557,295
Pork.....	7,683,583	8,529,730	9,314,703	10,778,523	8,456,898	10,750,697
Total.....	16,407,131	18,224,422	17,359,933	18,957,181	17,116,268	20,338,432
<b>Trend of consumption since 1900 (1900=100):</b>						
Beef.....	100.0	111.6	89.5	92.5	100.5	111.4
Mutton.....	100.0	104.7	128.7	110.0	83.0	90.5
Pork.....	100.0	111.0	121.2	140.3	110.1	139.9
Total.....	100.0	111.1	105.8	115.5	104.3	124.0
<b>Per capita consumption, in pounds:</b>						
Beef.....	106.7	99.9	73.5	73.6	78.7	85.9
Mutton.....	8.1	7.1	8.0	6.7	4.9	5.3
Pork.....	101.1	94.2	94.4	105.8	81.7	102.3
Total.....	215.9	201.1	176.0	186.1	165.4	193.5

<sup>1</sup> Excess of imports over domestic exports.

## SECTIONAL MEAT CONSUMPTION IN THE UNITED STATES.

By the processes of arriving at the meat consumption of this country, followed by the census method and by the estimates made in the Department of Agriculture, it has been impossible to determine what it is in any part of the Nation. Only a national average could be obtained. To provide information for each of the divisions into which the country is customarily divided, the Bureau of Crop Estimates has appealed to many of its local crop correspondents to make careful estimates of per capita consumption, with subdivision of the people of their districts into urban and rural, and estimates for each class. The request was for "pounds of dressed weight as would be sold by the butcher." The resulting averages for the United States, urban and rural combined, are approximately the same as those secured by national statistics and estimates of slaughter, reduced by the exported national surplus—lower for beef and higher for the other classes of meat. The interest of the investigation is chiefly in the geographic differences, and in the comparison between farm and town consumption; these can be observed in the accompanying table. Estimates were made for poultry as well as for "meat."

TABLE 310.—Estimated per capita meat consumption.

Class.	Total.	Beef.	Veal.	Mutton.	Pork.	Poultry.
	<i>Pounds.</i>	<i>Pounds.</i>	<i>Pounds.</i>	<i>Pounds.</i>	<i>Pounds.</i>	<i>Pounds.</i>
URBAN.						
North Atlantic.....	166.8	64.0	13.5	10.9	61.5	16.9
North Central, east.....	176.8	75.6	11.6	7.3	69.3	13.0
North Central, west.....	181.4	77.5	11.7	6.8	67.2	18.2
South Atlantic.....	158.4	55.1	5.7	5.4	76.3	16.0
South Central.....	178.4	66.1	4.4	8.7	79.7	19.5
Western.....	177.8	76.2	16.3	13.6	60.5	11.2
Total.....	171.6	68.3	11.8	9.3	66.3	15.8
RURAL.						
North Atlantic.....	174.7	47.1	10.7	7.6	85.5	23.9
North Central, east.....	196.2	48.3	7.2	5.8	109.9	25.1
North Central, west.....	212.7	57.4	6.3	3.8	113.1	32.0
South Atlantic.....	172.4	28.5	3.2	4.4	117.6	18.7
South Central.....	182.4	28.6	1.7	6.9	121.3	23.9
Western.....	188.2	64.7	9.3	15.8	81.5	16.9
Total.....	187.1	41.6	5.4	6.5	109.7	23.9
TOTAL POPULATION.						
North Atlantic.....	168.8	59.6	12.8	10.0	67.7	18.7
North Central, east.....	186.0	62.7	9.5	6.6	88.5	18.7
North Central, west.....	202.3	64.1	8.1	4.8	97.8	27.4
South Atlantic.....	168.9	35.2	3.8	4.7	107.1	18.0
South Central.....	181.6	36.3	2.3	7.3	112.8	23.0
Western.....	183.1	70.3	12.7	14.7	71.3	14.1
Total.....	179.9	54.0	8.4	7.8	89.6	20.2

States included in the different divisions are: North Atlantic—Maine, New Hampshire, Vermont, Massachusetts, Rhode Island, Connecticut, New York, New Jersey, Pennsylvania; North Central, east—Ohio, Indiana, Illinois, Michigan, Wisconsin; North Central, west—Minnesota, Iowa, Missouri, North Dakota, South Dakota, Nebraska, Kansas; South Atlantic—Delaware, Maryland, Virginia, West Virginia, North Carolina, South Carolina, Georgia, Florida; South Central—Kentucky, Tennessee, Alabama, Mississippi, Louisiana, Texas, Oklahoma, Arkansas; Western—Montana, Wyoming, Colorado, New Mexico, Arizona, Utah, Nevada, Idaho, Washington, Oregon, California.

TABLE 311.—United States foreign trade in meat animals and meat products, 1904-1919.

The following tabulation gives in round numbers the domestic exports and imports of meat animals, meats, and meat products yearly since 1904. Numbers of animals are given in thousands, i. e., 000 omitted. Quantities of meats and fats are given in millions of pounds, i. e., 000,000 omitted.

[United States Bureau of Foreign and Domestic Commerce.]

Year ending June 30—	Cattle.		Sheep.		Swine.	Meats.		Fats and oils.	
	Ex-ports.	Im-ports.	Ex-ports.	Im-ports.	Ex-ports.	Ex-ports.	Im-ports.	Ex-ports.	Im-ports.
1904.....	593	16	301	238	6	1,815	1	810	1
1905.....	568	28	268	187	44	1,802	3	827	3
1906.....	584	29	143	241	59	2,206	2	1,061	2
1907.....	423	32	135	225	24	1,968	2	958	1
1908.....	349	92	101	225	31	1,828	2	912	1
1909.....	208	139	68	103	19	1,484	4	767	4
1910.....	139	196	45	126	4	1,037	11	523	8
1911.....	150	183	121	53	9	1,193	9	687	6
1912.....	106	318	157	22	19	1,356	11	766	5
1913.....	25	425	187	15	15	1,196	15	695	10
1914.....	18	872	153	224	10	1,115	205	630	5
1915.....	5	539	47	153	8	1,544	226	620	2
1916.....	21	439	52	236	22	1,956	101	602	1
1917.....	13	375	59	160	22	1,950	22	566	1
1918.....	18	294	8	178	9	1,840	30	476	7
1919.....	42	440	16	163	17	2,476	199	848	12

RAILWAY FREIGHT TONNAGE.

TABLE 312.—Tonnage carried on railways in the United States, 1915-1918.<sup>1</sup>

Product.	Year ending June 30—		Year ending Dec. 31—		
	Class I and II roads.		Class I roads.		
	1915	1916	1916	1917	1918
FARM PRODUCTS.					
Animal matter:	<i>Short tons.</i>	<i>Short tons.</i>	<i>Short tons.</i>	<i>Short tons.</i>	<i>Short tons.</i>
Animals, live.....	15,021,432	16,963,922	17,294,304	17,905,829	17,257,034
Packing-house products—					
Dressed meats.....	2,503,317	2,656,235	2,807,571	2,965,709	3,713,766
Hides and leather.....	1,149,930	1,400,858	1,396,132	1,357,265	1,302,754
Other packing-house products.....	2,540,376	2,774,708	2,633,043	2,566,603	3,510,231
Total packing-house products.....	6,193,623	6,831,801	6,836,746	6,889,577	8,526,751
Poultry (including game and fish).....	861,670	1,016,484	1,096,624	1,022,472	1,154,040
Wool.....	370,426	503,248	504,927	499,054	493,651
Other animal matter.....	4,212,584	4,629,143	4,740,560	5,541,214	6,338,483
Total animal matter.....	26,659,735	29,944,598	30,473,161	31,858,146	35,769,959
Vegetable matter:					
Cotton.....	5,012,705	4,052,241	4,212,062	3,552,222	3,550,117
Fruit and vegetable.....	17,898,288	18,192,083	17,621,285	17,678,958	18,735,809
Grain and grain products—					
Grain.....	53,446,686	57,686,165	55,684,841	46,372,019	55,866,640
Grain products—					
Flour.....	9,596,763	10,472,225	10,318,950	10,065,219	10,587,769
Other grain products.....	8,036,745	7,992,496	8,234,081	8,413,089	8,630,062
Total grain and grain products.....	71,080,194	76,150,886	74,237,872	64,850,327	75,084,471
Hay.....	7,649,093	7,312,879	7,243,164	8,314,485	8,239,412
Sugar.....	3,727,194	3,917,381	3,762,495	4,235,353	4,204,165
Tobacco.....	1,051,648	1,085,843	1,016,198	1,028,771	1,159,572
Other vegetable matter.....	10,347,913	8,988,002	9,304,818	9,204,495	9,256,889
Total vegetable matter.....	116,767,035	119,699,295	117,397,894	108,864,611	120,230,435
Total farm products.....	143,426,770	149,643,893	147,871,055	140,722,757	156,000,394
OTHER FREIGHT.					
Products of mines.....	556,581,950	706,029,210	680,122,775	732,655,519	734,790,653
Products of forests.....	93,971,282	106,856,873	93,819,387	100,838,196	97,042,938
Manufactures.....	132,410,447	182,916,449	185,024,643	188,795,813	176,197,263
All other (including all freight in less than carload lots).....	76,013,494	92,776,482	95,162,207	101,006,438	99,031,942
Total tonnage.....	1,002,403,943	1,238,222,907	1,202,000,067	1,264,018,723	1,263,063,190

<sup>1</sup> Compiled from reports of the Interstate Commerce Commission. Original shipments only, excluding freight received by each railway from connecting railways and other carriers. Figures exclude the relatively small tonnage originating on railroads of Class III (roads having operating revenues of less than \$1,000,000 a year), except that for the calendar years 1916 and 1917 only Class I roads are included (roads having annual operating revenues in excess of \$1,000,000).

FARM TRACTORS.

[Manufacturers' estimate, furnished by the Bureau of Public Roads.]

TABLE 313.—Farm tractors in the United States.

On hand Dec. 31, 1917.....	<i>Number.</i> 15,525
Manufactured during 1918.....	132,697
Sold in United States during 1918.....	96,470
Sold for export during 1918.....	36,351
On hand Dec. 31, 1918.....	314,936

## FARM TRACTORS—Continued.

TABLE 313.—Tractors of different (belt-rated) horsepower manufactured 1918 and 1919.

Makers rating belt—	1918	1919 <sup>1</sup>	Makers rating belt—	1918	1919 <sup>1</sup>
	<i>Number.</i>	<i>Number.</i>		<i>Number.</i>	<i>Number.</i>
9, 10, 12 horsepower.....	1, 141	8, 220	35 and 36 horsepower.....		5, 435
16 and 18 horsepower.....	20, 629	48, 545	40 and 50 horsepower.....	1, 331	
20 and 22 horsepower.....	72, 238	157, 671	40, 45, 50 horsepower.....		1, 780
24 and 25 horsepower.....		40, 875	60, 65, 70, 80 horsepower.....	913	
24, 25, 26 horsepower.....	20, 616		60, 65, 70, 75, 80 horsepower.....		1, 536
27, 28, 30, 32 horsepower.....	2, 212	27, 465	Not given.....	6, 658	23, 409

<sup>1</sup> Estimated.

## WAGON AND MOTOR-TRUCK HAULS.

TABLE 314.—Wagon and motor-truck hauls from farms to shipping points, 1906 and 1918.

Item.	Dis- tance.	Round trips per day.	Load.			Cost of hauling per ton per mile.		
			Corn. <sup>1</sup>	Wheat.	Cotton.	Corn.	Wheat.	Cotton.
	<i>Miles.</i>	<i>Number.</i>	<i>Bushels.</i>	<i>Bushels.</i>	<i>Bales.</i>	<i>Cents.</i>	<i>Cents.</i>	<i>Cents.</i>
United States:								
Motor trucks, 1918.....	11.3	3.4	58	84	6.6	15	15	18
Wagons, 1918.....	9.0	1.2	39	56	3.6	33	30	48
Wagons, 1906.....	9.7	1.2	39	55	3.4	19	19	27
<i>Geographic division.<sup>2</sup></i>								
New England:								
Motor trucks, 1918.....	10.0	4.5	62	60		11	14	
Wagons, 1918.....	7.2	1.8	38	45		39	38	
Wagons, 1906.....	7.2	1.7						
Middle Atlantic:								
Motor trucks, 1918.....	12.2	3.4	69	78		14	14	
Wagons, 1918.....	7.6	1.6	39	47		39	38	
Wagons, 1906.....	6.5	1.7	41	48		24	26	
South Atlantic:								
Motor trucks, 1918.....	9.8	4.0	45	57	6.0	19	18	20
Wagons, 1918.....	8.4	1.4	29	36	3.5	41	39	48
Wagons, 1906.....	9.9	1.2	35	42	3.1	28	24	27
North Central, east:								
Motor trucks, 1918.....	9.3	4.8	64	90		11	9	
Wagons, 1918.....	6.3	2.0	41	54		29	26	
Wagons, 1906.....	7.0	1.8	40	48		16	18	
North Central, west:								
Motor trucks, 1918.....	10.1	3.8	54	84		18	14	
Wagons, 1918.....	7.9	1.5	42	57		33	29	
Wagons, 1906.....	8.7	1.4	39	52		17	16	
South Central, east:								
Motor trucks, 1918.....	12.9	3.2	58	86	7.6	12	10	13
Wagons, 1918.....	10.4	1.0	26	38	3.2	45	36	52
Wagons, 1906.....	11.1	1.0	29	37	3.0	24	23	31
South Central, west:								
Motor trucks, 1918.....	13.0	2.9	57	72	6.7	17	15	20
Wagons, 1918.....	10.9	1.0	26	46	3.8	49	32	47
Wagons, 1906.....	12.6	.9	29	38	3.8	22	21	26
Rocky Mountain:								
Motor trucks, 1918.....	21.0	1.2	48	70		36	29	
Wagons, 1918.....	20.2	.4	46	66		52	42	
Wagons, 1906.....	16.8	.7	49	60		16	20	
Pacific:								
Motor trucks, 1918.....	12.3	2.9	74	105		20	17	
Wagons, 1918.....	11.2	1.4	71	67		23	22	
Wagons, 1906.....	11.5	1.1	45	76		28	21	

<sup>1</sup> Not shelled.<sup>2</sup> The geographic divisions are—New England: Maine, New Hampshire, Vermont, Massachusetts, Rhode Island, Connecticut; Middle Atlantic: New York, New Jersey, Pennsylvania; South Atlantic: Delaware, Maryland, Virginia, West Virginia, North Carolina, South Carolina, Georgia, Florida; North Central east of the Mississippi River: Ohio, Indiana, Illinois, Michigan, Wisconsin; North Central west of the Mississippi River: Minnesota, Iowa, Missouri, North Dakota, South Dakota, Nebraska, Kansas; South Central east of the Mississippi River: Kentucky, Tennessee, Alabama, Mississippi; South Central west of the Mississippi River: Louisiana, Texas, Oklahoma, Arkansas; Rocky Mountain: Montana, Wyoming, Colorado, New Mexico, Arizona, Utah, Nevada, Idaho; Pacific: Washington, Oregon, California.

RURAL AND AGRICULTURAL POPULATION.

TABLE 315.—Rural and agricultural population in various countries.

Country.	Rural population.			Population dependent upon agriculture.		
	Year.	Number.	Per cent of total population.	Year.	Number.	Per cent of total population.
United States.....	1910	49,348,883	53.7			
Austria-Hungary:						
Austria.....				1900	13,447,362	51.4
Hungary.....				1900	13,061,118	67.8
Total Austria-Hungary.....				1900	26,508,480	58.4
Belgium.....	1910	1,654,277	22.3			
British India.....				1901	191,691,731	65.1
Bulgaria.....				1905	3,089,301	76.6
Denmark.....	1911	1,647,350	59.7	1911	1,023,962	37.1
Finland.....				1900	1,555,357	57.3
France.....	1906	22,715,011	57.9	1891	17,435,888	45.7
Germany.....				1907	17,089,496	27.7
Norway.....				1900	854,787	38.5
Portugal.....	1890	3,458,996	68.5	1900	3,367,199	62.1
Roumania.....	1900	4,836,904	81.2			
Russia:						
Caucasus.....				1897	7,266,428	78.2
Central Asia.....				1897	6,361,466	82.1
Poland.....				1897	5,302,850	56.4
Russia proper.....				1897	69,470,360	74.3
Siberia.....				1897	4,448,456	77.2
Total Russia.....				1897	92,849,560	73.9
Serbia.....				1900	2,097,988	84.2
Sweden.....				1900	2,344,612	45.6
Switzerland.....	1900	1,047,795	31.6	1900	1,067,905	32.2
United Kingdom:						
England and Wales.....	1911	7,907,556	21.9			

TABLE 316.—Number of persons engaged in agriculture in various countries.

Country.	Year.	Males.		Females.		Total persons engaged in agriculture.	
		Number.	Per cent of males in all occupations.	Number.	Per cent of females in all occupations.	Number.	Per cent of persons in all occupations.
United States.....	1910	10,582,039	35.2	1,806,584	22.4	12,388,623	32.5
Algeria.....	1881	636,078	74.8	91,602	53.7	727,680	71.3
Argentina.....	1895	318,149	28.0	67,174	13.4	385,323	23.6
Australia.....	1901	377,626	29.5	39,029	11.1	416,655	25.6
Austria-Hungary.....	1900	8,185,250	58.5	5,935,805	70.3	14,121,055	63.0
Belgium.....	1900	533,665	23.6	163,707	17.6	697,372	21.9
Bolivia.....	1900					564,009	43.5
British India.....	1901	63,026,365	67.3	27,867,210	66.5	90,893,575	67.1
British North Borneo.....	1901					32,892	64.2
Bulgaria.....	1905	895,206	73.3	837,406	94.9	1,732,612	82.4
Canada.....	1901	707,997	45.4	8,940	3.7	716,937	39.9
Ceylon.....	1901	745,074	65.0	318,551	65.4	1,063,625	65.1
Chile.....	1907	448,546	50.3	21,877	6.2	470,423	37.7
Cuba.....	1907	364,821	52.2	3,110	4.2	367,921	47.6
Cyprus.....	1901	33,611	62.8	2,757	20.8	36,368	54.5
Denmark.....	1911	386,016	45.7	110,169	28.5	496,185	40.3
Egypt.....	1907	2,258,005	67.2	57,144	33.3	2,315,149	65.6
Federated Malay States.....	1901	115,027	28.2	52,324	82.7	167,351	35.5
Finland.....	1900	321,538	51.4	102,008	39.6	423,546	48.0
Formosa.....	1905	763,456	70.6	263,664	82.4	1,027,120	73.3
France.....	1906	5,452,392	41.9	3,324,661	43.2	8,777,053	42.4
Germany.....	1907	5,146,723	27.7	4,585,749	48.3	9,732,472	34.6

## RURAL AND AGRICULTURAL POPULATION—Continued.

TABLE 316.—Number of persons engaged in agriculture in various countries—Contd.

Country.	Year.	Males.		Females.		Total persons engaged in agriculture.	
		Number.	Per cent of males in all occupations.	Number.	Per cent of females in all occupations.	Number.	Per cent of persons in all occupations.
Greece.....	1907	321,120	47.3	6,972	12.2	328,092	44.6
Grenada.....	1901	8,816	57.1	7,722	49.7	16,538	53.4
Italy.....	1901	6,370,277	57.9	3,196,063	60.5	9,566,340	58.8
Jamaica.....	1911					271,493	66.1
Malta and Gozo.....	1901	10,235	13.3	3,613	15.8	13,848	13.9
Mauritius.....	1901	72,493	57.1	5,989	38.0	78,482	55.0
Netherlands.....	1899	490,694	32.9	79,584	18.4	570,278	29.6
New Zealand.....	1911	103,644	28.5	7,472	8.3	111,116	24.5
Norway.....	1910					307,528	33.4
Philippine Islands.....	1903	1,163,777	57.8	90,286	8.8	1,254,063	41.3
Porto Rico.....	1899	196,893	73.3	1,868	3.9	198,761	62.8
Portugal.....	1900	1,127,268	65.3	380,293	52.0	1,507,561	61.4
Russia:							
In Europe.....	1897	13,808,505	59.6	1,974,164	38.0	15,782,669	55.6
In Asia.....	1897	2,092,965	69.2	105,137	30.5	2,198,102	65.3
Total.....	1897	15,901,470	60.7	2,079,301	37.5	17,980,771	56.7
St. Lucia.....	1901					15,736	54.1
Serbia.....	1900	311,700	65.5	13,524	50.5	325,224	64.7
Sierra Leone.....	1901	8,705	28.7	4,544	21.7	13,249	25.9
Spain.....	1900	3,741,730	58.1	775,270	51.8	4,517,000	56.9
Sweden.....	1900	761,016	52.4	333,264	53.8	1,094,280	52.8
Switzerland.....	1900	392,971	37.1	80,326	16.1	473,297	30.4
Trinidad and Tobago.....	1901	51,744	54.7	25,765	39.3	77,509	48.4
Union of South Africa.....	1904	863,223	56.3	847,057	77.5	1,710,280	65.1
United Kingdom.....	1901	2,109,812	16.3	152,642	2.9	2,262,454	12.4

## AGRICULTURAL LAND.

TABLE 317.—Total area and agricultural land in various countries.

[As classified and reported by the International Institute of Agriculture.]

Country.	Year.	Total area.	Productive land. <sup>1</sup>		Cultivated land. <sup>2</sup>	
			Amount.	Per cent of total area.	Amount.	Per cent of total area.
NORTH AMERICA.						
United States.....	1910	Acres. 1,903,269,000	Acres. 878,789,000	Per cent. 46.2	Acres. 293,794,000	Per cent. 15.4
Canada.....	1901	2,397,082,000	63,420,000	2.6	19,880,000	.8
Costa Rica.....	1909-10	13,343,000	3,090,000	23.2	442,000	3.3
Cuba.....	1899	28,299,000	8,717,000	30.8	778,000	2.7
SOUTH AMERICA.						
Argentina.....	1909-10	729,575,000	537,805,000	73.7	44,446,000	6.1
Chile <sup>3</sup> .....	1910-11	187,145,000	15,144,000	8.1	2,557,000	1.4
Uruguay.....	1908	46,189,000	40,875,000	88.5	1,962,000	4.2
EUROPE.						
Austria-Hungary:						
Austria.....	1911	74,132,000	69,939,000	94.3	26,272,000	35.4
Hungary.....	1910	80,272,000	77,225,000	96.2	35,178,000	43.8
Total Austria-Hungary.....		154,404,000	147,164,000	95.3	61,450,000	39.8

<sup>1</sup> Includes, besides cultivated land, also natural meadows and pastures, forests, wood lots, and lands devoted to cultivated trees and shrubs.

<sup>2</sup> Includes fallow lands; also artificial grasslands.

<sup>3</sup> The figure for "productive land" in Chile excludes marshes, heaths, and productive but uncared-for lands.

## AGRICULTURAL LAND—Continued.

TABLE 317.—Total area and agricultural land in various countries—Continued.

Country.	Year.	Total area.	Productive land.		Cultivated land.	
			Amount.	Per cent of total area.	Amount.	Per cent of total area.
EUROPE—continued.						
Belgium.....	1895	7,278,000	6,443,000	88.5	3,582,000	49.2
Bulgaria.....	1910	23,807,000	18,959,000	79.6	8,574,000	36.0
Denmark.....	1907	9,629,000	9,078,000	94.3	6,376,000	66.2
Finland.....	1901	82,113,000	.....	.....	3,875,000	4.7
France.....	1910	130,854,000	123,642,000	94.5	59,124,000	45.2
Germany.....	1900	133,594,000	126,401,000	94.6	63,689,000	47.7
Italy.....	1911	70,839,000	65,164,000	92.0	33,815,000	47.7
Luxemburg.....	1911	639,000	616,000	96.4	300,000	46.9
Netherlands.....	1911	8,057,000	7,258,000	90.1	2,210,000	27.4
Norway.....	1907	79,810,000	22,942,000	28.7	1,830,000	2.3
Portugal.....	1912	22,018,000	17,281,000	78.5	5,777,000	26.2
Roumania.....	1905	32,167,000	24,645,000	76.6	14,829,000	46.1
Russia, European.....	1911	1,278,203,000	698,902,000	54.7	245,755,000	19.2
Serbia.....	1897	11,936,000	6,246,000	52.3	2,534,000	21.2
Spain.....	1908-1911	124,666,000	112,665,000	90.4	41,264,000	33.1
Sweden.....	1911	110,667,000	65,196,000	58.9	9,144,000	5.9
Switzerland <sup>1</sup> .....	1905	10,211,000	7,635,000	74.8	605,000	8.3
United Kingdom:						
Great Britain.....	1911	56,802,000	47,737,000	84.0	14,587,000	25.7
Ireland.....	1911	20,350,000	18,789,000	92.3	3,275,000	16.1
Total United Kingdom.....		77,152,000	66,526,000	86.2	17,862,000	23.2
ASIA.						
British India.....	1910-11	615,695,000	465,706,000	75.6	264,858,000	43.0
Formosa.....	1911	8,858,000	1,972,000	22.3	1,884,000	21.3
Japan.....	1911	94,495,000	74,180,000	78.5	17,639,000	18.7
Russia, Asiatic.....	1911	4,028,001,000	715,838,000	17.8	33,860,000	.8
AFRICA.						
Algeria.....	1910	124,976,000	50,846,000	40.7	11,434,000	9.1
Egypt.....	1912	222,390,000	5,486,000	2.5	5,457,000	2.5
Tunis.....	1912	30,888,000	22,239,000	72.0	6,919,000	22.4
Union of South Africa.....	1909-10	302,827,000	3,569,000	1.2	3,385,000	1.1
OCEANIA.						
Australia.....	1910-11	1,903,664,000	119,942,000	6.3	14,987,000	.8
New Zealand.....	1910	66,469,000	57,310,000	86.2	6,955,000	10.5
Total, 36 countries.....		15,071,209,000	4,591,691,000	30.5	1,313,832,000	8.7

<sup>1</sup> The figure for "cultivated land" in Switzerland excludes artificial meadows and pastures.

## NATIONAL FORESTS.

TABLE 318.—National Forests: Timber disposed of, quantity, price, and number of users, revenue under specified heads, and details of grazing privileges, years ended June 30, 1915 to 1919.

[Reported by the Forest Service.]

Item.	Year ended June 30—				
	1915	1916	1917	1918	1919
Free timber given:					
Number of users.....	40,040	42,055	41,427	38,073	34,617
Timber cut..... M ft.	123,259	119,483	113,073	98,376	90,798
Value..... dolls.	206,597	184,715	149,802	128,866	113,117
Timber sales:					
Number.....	10,905	10,840	11,608	13,037	12,592
Quantity..... M ft.	1,093,589	906,906	2,008,087	1,453,299	799,476
Price per thousand board feet (average)..... dolls.	2.44	1.98	1.85	2.28	2.30

## NATIONAL FORESTS—Continued.

TABLE 318.—National Forests: Timber disposed of, quantity, price, and number of users, revenue under specified heads, and details of grazing privileges, years ended June 30, 1915, to 1919—Continued.

Item.	Year ended June 30—				
	1915	1916	1917	1918	1919
Grazing:					
Number of permits.....	30,610	33,328	36,638	39,113	39,152
Kinds of stock—					
Cattle.....Number.....	1,627,321	1,758,764	1,953,198	2,137,854	2,135,527
Cats.....Number.....	51,409	43,268	49,939	57,968	60,789
Hogs.....Number.....	2,792	2,968	2,306	3,371	5,154
Horses.....Number.....	96,933	98,903	98,880	102,156	93,251
Sheep.....Number.....	7,232,276	7,843,205	7,586,034	8,454,240	7,935,174
Total.....	9,010,731	9,747,108	9,690,357	10,755,589	10,229,895
Special use and water-power permits .....Number.....	5,657	5,251	6,056	5,819	5,191
Revenue:					
From—					
Timber sales.....dolls.....	1,211,985	1,367,111	1,595,873	1,519,867	1,503,367
Timber settlements <sup>1</sup> .....dolls.....	3,181	2,299	17,102	99,502	8,939
Timber trespass.....dolls.....	7,284	37,712	18,870	2,330	8,623
Turpentine sales.....dolls.....	8,915	14,402	8,156	8,334	13,220
Turpentine trespass.....dolls.....					692
Fire trespass.....dolls.....	661	5,471	52,514	3,618	5,259
Occupancy trespass.....dolls.....				1,207	689
Special uses.....dolls.....	78,691	85,235	108,329	119,979	136,134
Grazing fees.....dolls.....	1,130,175	1,202,405	1,544,714	<sup>2</sup> 1,702,585	2,556,962
Grazing trespass.....dolls.....	5,818	7,810	5,081	23,532	52,208
Water power.....dolls.....	89,104	101,096	106,389	93,976	72,322
Total revenue, dollars.....	<sup>3</sup> 2,535,814	2,823,541	3,457,028	3,574,930	4,358,415

<sup>1</sup> Includes timber taken in the exercise of permits for rights of way, development of power, etc.

<sup>2</sup> Includes \$296 from sale of live stock.

<sup>3</sup> Refunds during year, \$54,575.

TABLE 319.—Area of National Forest lands, June 30, 1919.

[Reported by the Forest Service.]

State and forest.	Net area.	State and forest.	Net area.
Alabama:	<i>Acres.</i>	California:	<i>Acres.</i>
Alabama.....	36,418	Angeles.....	817,441
Alaska:		California.....	807,408
Chugach.....	5,124,826	Cleveland.....	547,851
Tongass.....	15,449,717	Crater <sup>1</sup> .....	47,097
Total.....	20,574,543	Eldorado <sup>1</sup> .....	549,060
Arizona:		Inyo <sup>1</sup> .....	1,191,209
Apache.....	1,182,179	Klamath <sup>1</sup> .....	1,498,824
Coconino.....	1,650,095	Lassen.....	936,957
Coronado <sup>1</sup> .....	1,305,698	Modoc.....	1,186,273
Crook.....	870,106	Mono <sup>1</sup> .....	785,701
Dixie <sup>1</sup> .....	17,680	Monterey.....	320,281
Kaibab.....	752,339	Plumas.....	1,144,418
Prescott.....	1,432,600	Santa Barbara.....	1,689,251
Sitgreaves.....	650,877	Sequoia.....	1,875,900
Tonto.....	1,993,395	Shasta.....	890,014
Tusayan.....	1,299,954	Sierra.....	1,488,655
Total.....	11,154,923	Siskiyou <sup>1</sup> .....	348,919
Arkansas:		Stanislaus.....	810,802
Arkansas <sup>2</sup> .....	627,149	Tahoe <sup>1</sup> .....	531,210
Ozark <sup>3</sup> .....	274,672	Trinity.....	1,428,388
Total.....	901,821	Total.....	18,814,659
		Colorado:	
		Arapahoe.....	634,452
		Battlement.....	646,918
		Cochetopa.....	916,975
		Colorado.....	850,240

<sup>1</sup> For total area, see Table 320, "National Forests extending into two States."

<sup>2</sup> Includes 1,240 acres acquired under the Weeks law.

<sup>3</sup> Includes 158 acres acquired under the Weeks law.



## NATIONAL FORESTS—Continued.

TABLE 319.—Area of National Forest lands, June 30, 1919—Continued.

State and forest.	Net area.	State and forest.	Net area.
Colorado—Continued.	<i>Acres.</i>	Nevada:	<i>Acres.</i>
Durango.....	620,365	Dixie <sup>1</sup> .....	56,483
Gunnison.....	905,798	Eldorado <sup>1</sup> .....	400
Hayden <sup>1</sup> .....	65,598	Humboldt.....	1,313,730
Holy Cross.....	575,511	Inyo <sup>1</sup> .....	56,391
La Sal <sup>1</sup> .....	27,444	Mono <sup>1</sup> .....	464,316
Leadville.....	929,451	Nevada.....	1,158,177
Montezuma.....	701,084	Tahoe <sup>1</sup> .....	13,853
Pike.....	1,077,645	Toiyabe.....	1,907,985
Rio Grande.....	1,136,219	Total.....	4,971,335
Routt.....	743,481		
San Isabel.....	598,912	New Hampshire:	
San Juan.....	618,983	White Mountain <sup>1</sup> .....	332,778
Sopris.....	596,578		
Uncompahgre.....	789,556	New Mexico:	
White River.....	845,595	Carson.....	860,974
Total.....	13,280,832	Coronado <sup>1</sup> .....	126,318
		Datil.....	2,652,316
Florida:		Gila.....	1,466,564
Florida.....	308,268	Lincoln.....	1,123,693
		Manzano.....	697,488
Idaho:		Santa Fe.....	1,366,869
Boise.....	1,058,941	Total.....	8,294,222
Cache <sup>1</sup> .....	493,430		
Caribou <sup>1</sup> .....	678,207	North Carolina:	
Challis.....	1,258,214	Pisgah.....	79,461
Clearwater.....	785,062		
Coeur d'Alene.....	662,592	Oklahoma:	
Idaho.....	1,170,774	Wichita.....	61,480
Kaniksu <sup>1</sup> .....	197,476		
Lemhi.....	1,095,924	Oregon:	
Minidoka <sup>1</sup> .....	509,226	Cascade.....	1,020,695
Nez Perce.....	1,625,024	Crater <sup>1</sup> .....	799,102
Payette.....	831,926	Deschutes.....	1,282,552
Pend Oreille.....	675,293	Fremont.....	851,210
St. Joe.....	556,438	Klamath <sup>1</sup> .....	4,401
Salmon.....	1,621,250	Malheur.....	1,057,682
Sawtooth.....	1,159,987	Minam.....	433,192
Selway.....	1,688,287	Ochoco.....	716,604
Targhee <sup>1</sup> .....	977,181	Oregon.....	1,043,527
Weiser.....	561,560	Santiam.....	607,097
Total.....	17,606,792	Siskiyou <sup>1</sup> .....	997,798
		Siuslaw.....	543,237
Maine:		Umatilla.....	485,786
White Mountain <sup>1</sup> .....	27,860	Umpqua.....	1,010,824
		Wallowa.....	957,379
Michigan:		Wenaha <sup>1</sup> .....	425,278
Michigan.....	89,466	Whitman.....	882,316
		Total.....	13,118,680
Minnesota:			
Minnesota.....	190,602	Porto Rico:	
Superior.....	853,631	Luquillo.....	12,443
Total.....	1,044,233		
		South Dakota:	
Montana:		Black Hills <sup>1</sup> .....	477,593
Absaroka.....	841,085	Harney.....	544,273
Beartooth.....	662,136	Sioux <sup>1</sup> .....	75,209
Beaverhead.....	1,334,849	Total.....	1,097,075
Bitterroot.....	1,047,289		
Blackfeet.....	902,695	Utah:	
Cabinet.....	833,229	Ashley <sup>1</sup> .....	975,058
Custer.....	429,936	Cache <sup>1</sup> .....	268,501
Deerlodge.....	831,153	Dixie <sup>1</sup> .....	434,280
Flathead.....	1,717,118	Fillmore.....	700,744
Gallatin.....	567,614	Fishlake.....	657,482
Helena.....	680,257	La Sal <sup>1</sup> .....	508,887
Jefferson.....	1,043,004	Manti.....	783,107
Kootenai.....	1,333,264	Minidoka <sup>1</sup> .....	72,123
Lewis and Clark.....	810,990	Powell.....	688,412
Lolo.....	850,677	Sevier.....	722,180
Madison.....	944,283	Uinta.....	1,001,168
Missoula.....	1,031,418	Wasatch.....	603,568
Sioux <sup>1</sup> .....	96,199	Total.....	7,415,510
Total.....	15,957,196		
		Nebraska:	
Nebraska:		Nebraska.....	205,944
Nebraska.....	205,944		

<sup>1</sup> For total area, see Table 320, "National Forests extending into two States."

## NATIONAL FORESTS—Continued.

TABLE 319.—Area of National Forest lands, June 30, 1919—Continued.

State and forest.	Net area.	State and forest.	Net area.
Virginia:	<i>Acres.</i>	Wyoming:	<i>Acres.</i>
Natural Bridge.....	77,401	Ashley <sup>1</sup> .....	5,987
Shenandoah <sup>1</sup> .....	132,256	Bighorn.....	1,122,277
Total.....	209,657	Black Hills <sup>1</sup> .....	144,497
Washington:		Bridger.....	712,709
Chelan.....	677,590	Caribou <sup>1</sup> .....	6,311
Columbia.....	785,389	Hayden <sup>1</sup> .....	324,656
Colville.....	754,514	Medicine Bow.....	477,038
Kaniksu <sup>1</sup> .....	257,603	Shoshone.....	1,576,502
Okanogan.....	1,488,352	Targhee <sup>1</sup> .....	335,481
Olympic.....	1,534,583	Teton.....	1,920,671
Ranier.....	1,314,302	Washakie.....	852,315
Snoqualmie.....	697,535	Wyoming.....	905,730
Washington.....	1,459,876	Total.....	8,384,174
Wenaha <sup>1</sup> .....	313,434	Total, National Forests.....	153,933,460
Wenatchie.....	657,194	Appalachian area <sup>2</sup> .....	646,776
Total.....	9,940,372	Grand total.....	154,580,236
West Virginia:			
Shenandoah <sup>1</sup> .....	13,318		

<sup>1</sup> For total area, see Table 320: "National Forests extending into two or more States."<sup>2</sup> Acquired under the Weeks law.

TABLE 320.—National Forests extending into two or more States.

Forest.	States.	Net area.
		<i>Acres.</i>
Coronado.....	Arizona-New Mexico.....	1,432,016
Dixie.....	Arizona-Nevada-Utah.....	508,443
Crater.....	California-Oregon.....	846,199
Eldorado.....	California-Nevada.....	549,460
Inyo.....	do.....	1,247,600
Klamath.....	California-Oregon.....	1,503,225
Mono.....	California-Nevada.....	1,250,017
Siskiyou.....	California-Oregon.....	1,346,717
Tahoe.....	California-Nevada.....	545,063
Hayden.....	Colorado-Wyoming.....	390,254
La Sal.....	Colorado-Utah.....	536,331
Cache.....	Idaho-Utah.....	761,931
Caribou.....	Idaho-Wyoming.....	684,518
Kaniksu.....	Idaho-Washington.....	455,079
Minidoka.....	Idaho-Utah.....	581,349
Targhee.....	Idaho-Wyoming.....	1,312,662
Sioux.....	Montana-South Dakota.....	171,408
Wenaha.....	Oregon-Washington.....	738,712
Black Hills.....	South Dakota-Wyoming.....	622,090
Ashley.....	Utah-Wyoming.....	981,045
White Mountain.....	Maine-New Hampshire.....	360,638
Shenandoah.....	Virginia-West Virginia.....	145,574

NATIONAL FORESTS—Continued.

TABLE 321.—Grazing allowances for National Forests, 1919.

[Reported by the Forest Service. The symbols (+) or (-) indicate, respectively, that there was an increase or decrease in 1919 compared with 1918. The figures themselves refer to actual numbers of stock authorized in 1919.]

Forest.	Number of stock authorized.			Yearlong rates (cents).			
	Cattle and horses.	Swine.	Sheep and goats.	Cattle.	Horses.	Swine.	Sheep and goats.
<b>District 1:</b>							
Absaroka.....	+ 7,510	.....	- 82,600	100	125	75	25
Beartooth <sup>1</sup> .....	5,200	300	47,000	100	125	75	25
Beaverhead <sup>1</sup> .....	+ 29,250	.....	+ 142,000	100	125	75	25
Bitterroot.....	4,500	.....	- 67,000	100	125	75	25
Blackfeet.....	1,500	.....	+ 25,000	80	100	60	20
Cabinet.....	2,400	.....	25,000	80	100	60	20
Clearwater.....	2,400	.....	25,000	80	100	60	20
Coeur d'Alene.....	1,000	.....	20,000	80	100	60	20
Custer <sup>2</sup> .....	21,500	.....	6,000	120	150	90	30
Deerlodge <sup>1</sup> .....	+ 17,500	.....	- 58,800	100	125	75	25
Flathead.....	- 1,200	.....	.....	80	100	60	20
Gallatin.....	- 5,910	.....	- 46,600	120	150	90	30
Helena.....	- 18,950	.....	- 67,000	100	125	75	25
Jefferson <sup>1</sup> .....	- 22,650	.....	- 117,600	100	125	75	25
Kaniksu.....	- 650	.....	12,000	80	100	60	20
Kootenai.....	2,850	.....	30,000	80	100	60	20
Lewis and Clark.....	+ 9,950	.....	43,500	100	125	75	25
Lolo.....	+ 1,000	.....	+ 50,000	80	100	60	20
Madison <sup>1</sup> .....	31,000	.....	141,800	120	150	90	30
Missoula.....	- 10,800	.....	10,500	100	125	75	25
Nezperce.....	- 14,300	.....	+ 115,500	120	150	90	30
Pend Oreille.....	1,400	.....	31,500	80	100	60	20
Selway.....	5,250	.....	+ 36,000	80	100	60	20
Sioux <sup>2</sup> .....	- 7,750	.....	2,800	100	125	75	25
St. Joe.....	400	.....	32,000	80	100	60	20
	-226,820	300	+1,235,200				
<b>District 2:</b>							
Arapaho <sup>1</sup> .....	- 12,650	.....	+ 28,500	100	125	75	25
Battlement <sup>1</sup> .....	+ 48,750	.....	+ 10,000	100	125	75	25
Bighorn <sup>1</sup> .....	47,485	.....	+ 128,900	120	150	90	30
Black Hill <sup>2</sup> .....	+ 30,000	.....	+ 7,450	100	125	75	25
Cochetopa <sup>1</sup> .....	+ 20,200	.....	- 74,500	100	125	75	25
Colorado.....	- 25,100	.....	- 11,360	100	125	75	25
Durango <sup>1</sup> .....	+ 13,225	.....	+ 96,500	100	125	75	25
Gunnison <sup>1</sup> .....	+ 36,875	.....	- 50,900	100	125	75	25
Harney <sup>1</sup> .....	+ 14,850	.....	.....	100	125	75	25
Hayden <sup>3</sup> .....	- 7,400	.....	+ 144,100	100	125	75	25
Holy Cross <sup>1</sup> .....	+ 16,175	.....	+ 48,875	100	125	75	25
Leadville <sup>1</sup> .....	- 12,800	.....	105,000	100	125	75	25
Medicine Bow <sup>1</sup> .....	+ 12,300	.....	57,100	100	125	75	25
Michigan.....	1,250	.....	3,300	100	125	75	25
Minnesota.....	2,000	.....	.....	100	125	75	25
Montezuma <sup>1</sup> .....	+ 37,000	.....	+ 52,500	100	125	75	25
Nebraska.....	- 15,000	.....	.....	150	187	112½	37½
Pike <sup>1</sup> .....	+ 20,000	.....	+ 23,100	100	125	75	25
Rio Grande <sup>1</sup> .....	+ 25,350	.....	284,000	100	125	75	25
Routt <sup>3</sup> .....	- 28,600	.....	- 89,620	100	125	75	25
San Isabel <sup>1</sup> .....	16,000	.....	+ 19,600	100	125	75	25
San Juan <sup>1</sup> .....	- 13,320	.....	102,900	100	125	75	25
Shoshone <sup>1</sup> .....	+ 14,420	.....	+ 74,750	100	125	75	25
Sopris <sup>1</sup> .....	- 13,500	.....	- 52,000	100	125	75	25
Uncompahgre <sup>1</sup> .....	+ 34,200	.....	+ 62,500	100	125	75	25
Washakie <sup>1</sup> .....	12,500	.....	+ 51,000	100	125	75	25
White River <sup>1</sup> .....	- 40,250	.....	- 35,250	100	125	75	25
	+571,200		+1,613,705				
<b>District 3:</b>							
Apache <sup>1</sup> .....	+ 48,000	180	- 60,000	100	125	75	25
Carson <sup>2</sup> .....	+ 11,300	200	- 155,300	100	125	75	25
Coconino <sup>1</sup> .....	+ 51,000	- 100	94,000	100	125	75	25
Coronado <sup>2</sup> .....	+ 54,000	200	+ 9,300	100	125	75	25
Crook <sup>2</sup> .....	+ 29,760	100	1,350	100	125	75	25
Datil <sup>1</sup> .....	+ 56,000	225	147,000	100	125	75	25
Gila <sup>1</sup> .....	59,000	440	13,100	100	125	75	25

<sup>1</sup> 5-year permits authorized for cattle and horses and sheep and goats.

<sup>2</sup> 5-year permits authorized for cattle.

<sup>3</sup> 5-year permits authorized for sheep.

## NATIONAL FORESTS—Continued.

TABLE 321.—Grazing allowances for National Forests, 1919—Continued.

Forest.	Number of stock authorized.			Yearlong rates (cents).			
	Cattle and horses.	Swine.	Sheep and goats.	Cattle.	Horses.	Swine.	Sheep and goats.
District 3—Continued.							
Lincoln <sup>1</sup> .....	+ 30,600	1,200	+ 26,600	100	125	75	25
Manzano <sup>1</sup> .....	9,800	.....	85,000	100	125	75	25
Prescott <sup>1</sup> .....	+ 64,000	100	68,500	100	125	75	25
Santa Fe <sup>1</sup> .....	- 18,000	- 400	- 121,000	100	125	75	25
Sitgreaves <sup>2</sup> .....	+ 10,395	.....	68,500	100	125	75	25
Tonto <sup>3</sup> .....	- 66,000	500	100	100	125	75	25
Tusayan <sup>1</sup> .....	- 28,900	160	- 75,200	100	125	75	25
	+ 536,755	- 3,805	- 924,950	.....	.....	.....	.....
District 4:							
Ashley <sup>1</sup> .....	- 11,000	.....	- 100,000	100	125	75	25
Boise <sup>1</sup> .....	+ 5,200	100	148,000	120	150	90	30
Bridger <sup>1</sup> .....	+ 30,400	.....	- 66,000	120	150	90	30
Cache <sup>1</sup> .....	- 30,200	.....	- 131,000	120	150	90	30
Caribou <sup>1</sup> .....	+ 23,500	.....	281,000	120	150	90	30
Challis <sup>1</sup> .....	+ 9,300	.....	- 90,000	100	125	75	25
Dixie <sup>3</sup> .....	+ 9,000	400	1,000	100	125	75	25
Fillmore.....	- 20,400	500	- 32,600	120	150	90	30
Fishlake <sup>2</sup> .....	18,500	.....	- 67,000	120	150	90	30
Humboldt.....	- 54,850	.....	- 339,000	120	150	90	30
Idaho <sup>1</sup> .....	- 2,000	.....	+ 107,000	120	150	90	30
Kaibab.....	- 9,200	.....	5,000	100	125	75	25
La Sal <sup>1</sup> .....	- 25,900	+ 150	- 37,800	100	125	75	25
Lemhi <sup>1</sup> .....	+ 18,700	.....	- 69,000	120	150	90	30
Manti.....	- 22,600	.....	- 139,000	120	150	90	30
Minidoka <sup>1</sup> .....	- 25,000	.....	77,000	120	150	90	30
Nevada <sup>1</sup> .....	+ 6,100	.....	+ 52,000	100	125	75	25
Payette <sup>1</sup> .....	- 7,700	.....	- 85,000	120	150	90	30
Powell <sup>1</sup> .....	+ 13,800	.....	75,000	100	125	75	25
Salmon <sup>1</sup> .....	- 15,750	.....	- 110,000	100	125	75	25
Sawtooth <sup>1</sup> .....	+ 11,200	.....	- 285,000	120	150	90	30
Sevier <sup>1</sup> .....	+ 11,800	50	113,000	100	125	75	25
Targhee <sup>1</sup> .....	+ 36,100	.....	234,000	120	150	90	30
Teton.....	- 12,500	.....	20,000	120	150	90	30
Toiyabe <sup>1</sup> .....	+ 23,300	.....	24,000	100	125	75	25
Uinta <sup>1</sup> .....	+ 39,200	.....	- 194,000	120	150	90	30
Wasatch <sup>1</sup> .....	+ 14,000	.....	- 60,000	120	150	90	30
Weiser <sup>1</sup> .....	- 13,300	.....	- 63,000	120	150	90	30
Wyoming <sup>1</sup> .....	+ 13,500	.....	197,000	120	150	90	30
	- 534,000	- 1,200	- 3,202,400	.....	.....	.....	.....
District 5:							
Angeles <sup>1</sup> .....	4,100	.....	.....	120	150	90	30
California <sup>1</sup> .....	- 7,900	+ 500	- 50,000	120	150	90	30
Cleveland <sup>1</sup> .....	1,800	.....	+ 4,800	120	150	90	30
Eldorado <sup>1</sup> .....	11,725	.....	21,200	140	175	105	35
Inyo <sup>1</sup> .....	+ 8,500	.....	+ 50,100	140	175	105	35
Klamath <sup>1</sup> .....	+ 10,250	+ 1,150	32,000	100	125	75	25
Lassen <sup>1</sup> .....	13,550	300	42,000	120	150	90	30
Modoc <sup>1</sup> .....	- 45,500	.....	+ 65,000	120	150	90	30
Mono <sup>1</sup> .....	5,800	.....	+ 81,000	140	175	105	35
Plumas <sup>1</sup> .....	+ 17,100	.....	+ 91,450	140	175	105	35
Santa Barbara <sup>1</sup> .....	- 10,625	- 300	+ 11,500	120	150	90	30
Sequoia <sup>3</sup> .....	29,900	600	19,800	140	175	105	35
Shasta <sup>1</sup> .....	+ 12,500	200	+ 36,800	120	150	90	30
Sierra <sup>1</sup> .....	- 18,500	+ 1,300	- 76,750	140	175	105	35
Stanislaus <sup>1</sup> .....	20,625	+ 400	+ 13,000	140	175	105	35
Tahoe <sup>1</sup> .....	9,050	50	55,000	140	175	105	35
Trinity <sup>1</sup> .....	13,050	415	24,100	100	125	75	25
	- 240,475	+ 5,215	+ 674,500	.....	.....	.....	.....
District 6:							
Cascade <sup>1</sup> .....	1,100	.....	27,000	120	150	90	30
Chelan <sup>2</sup> .....	550	.....	35,000	120	150	90	30
Columbia <sup>1</sup> .....	1,300	.....	15,600	120	150	90	30
Colville <sup>1</sup> .....	+ 8,000	.....	- 50,000	120	150	90	30
Crater <sup>1</sup> .....	+ 18,000	.....	+ 24,700	120	150	90	30
Deschutes <sup>1</sup> .....	+ 8,200	.....	- 25,300	120	150	90	30

<sup>1</sup> 5-year permits authorized for cattle and horses and sheep and goats.<sup>2</sup> 5-year permits authorized for sheep.<sup>3</sup> 5-year permits authorized for cattle.

## NATIONAL FORESTS—Continued.

TABLE 321.—Grazing allowances for National Forests, 1919—Continued.

Forest.	Number of stock authorized.			Yearlong rates (cents).			
	Cattle and horses.	Swine.	Sheep and goats.	Cattle.	Horses.	Swine.	Sheep and goats.
District 6—Continued.							
Fremont <sup>1</sup> .....	15,000	.....	95,000	120	150	90	30
Malheur <sup>1</sup> .....	+ 32,000	+ 50	121,000	120	150	90	30
Minam <sup>1</sup> .....	- 15,050	.....	- 72,000	120	150	90	30
Ochoco <sup>1</sup> .....	+ 19,500	.....	+ 85,000	120	150	90	30
Okanogan <sup>1</sup> .....	15,500	.....	100,000	120	150	90	30
Olympic.....	2,500	.....	.....	100	125	75	25
Oregon <sup>1</sup> .....	+ 4,100	.....	23,000	120	150	90	30
Rainier <sup>1</sup> .....	- 7,700	.....	- 58,000	120	150	90	30
Santiam <sup>1</sup> .....	350	.....	20,000	120	150	90	30
Siskiyou.....	4,100	1,000	4,200	100	125	75	25
Siuslaw.....	1,500	.....	7,000	100	125	75	25
Snoqualmie.....	.....	.....	7,200	120	150	90	30
Umatilla <sup>1</sup> .....	+ 10,300	.....	- 55,500	120	150	90	30
Umpqua <sup>1</sup> .....	1,400	.....	+ 10,500	120	150	90	30
Wallowa <sup>1</sup> .....	+ 28,500	.....	- 66,000	120	150	90	30
Washington.....	250	.....	5,000	100	125	75	25
Wenaha <sup>1</sup> .....	13,100	.....	102,700	120	150	90	30
Wenatchee <sup>2</sup> .....	950	.....	66,000	120	150	90	30
Whitman <sup>1</sup> .....	+ 11,975	.....	- 105,000	120	150	90	30
	+220,925	+1,050	-1,180,700	.....	.....	.....	.....
District 7:							
Arkansas.....	30,000	22,000	2,000	80	100	60	20
Florida.....	6,000	3,000	7,000	80	100	60	20
Ozark.....	7,890	9,865	1,972	80	100	60	20
Wichita.....	4,710	.....	.....	150	187	112½	37½
	48,600	34,865	10,972	.....	.....	.....	.....
Purchase areas:							
Alabama.....	+ 200	.....	.....	150	200	90	45
Cherokee-Georgia.....	3,800	1,200	1,000	150	200	90	45
Monongahela.....	400	40	100	150	200	90	45
Natural Bridge.....	400	.....	.....	150	200	90	45
Pisgah.....	1,000	100	550	150	200	90	45
Savannah.....	710	560	430	150	200	90	45
Shenandoah.....	2,580	100	750	150	200	90	45
White Mountain.....	110	.....	.....	150	200	90	45
White Top.....	1,000	450	350	150	200	90	45
	+10,200	2,450	3,180	.....	.....	.....	.....
Totals, 1913.....	1,852,999	59,535	8,521,308	.....	.....	.....	.....
Totals, 1914.....	1,891,119	65,645	8,867,906	.....	.....	.....	.....
Totals, 1915.....	1,983,775	64,040	8,747,025	.....	.....	.....	.....
Totals, 1916.....	2,008,675	58,990	8,597,689	.....	.....	.....	.....
Totals, 1917.....	2,120,145	54,680	8,400,155	.....	.....	.....	.....
Totals, 1918.....	2,359,402	51,685	8,937,837	.....	.....	.....	.....
Totals, 1919.....	2,388,975	48,885	8,845,607	.....	.....	.....	.....
Increase or decrease in 1919 over 1918.....	+ 29,573	- 2,800	- 92,230	.....	.....	.....	.....

<sup>1</sup> 5-year permits authorized for cattle and horses and sheep and goats.<sup>2</sup> 5-year permits authorized for sheep.

## INDEX.

---

	Page.
Abbreviations, use in market reports, definitions-----	98
Abortion, contagious, of cattle, note-----	78
Absentee landlordism, discussion on limiting-----	31-32
Accounting systems, farm projects, preparation and installation-----	44
Accredited herd, use in eradication of tuberculosis, advantages-----	279
African horse sickness, symptoms, occurrence and fatality-----	72
Agent, purchasing association, duties and powers-----	388, 389
Agents, county, relation to marketing demonstrations, discussion-----	206-208
Agrarians, stimulation of agriculture in Germany, purpose and methods-----	61-62
Agricultural—	
colleges, location, and officials-----	497-499
experiment stations, location and directors-----	499
extension work, cooperative, State officers-----	500-501
production, influence of depreciation of exchange, article by Alonzo Englebert Taylor-----	189-196
products—	
imports and exports-----	682-721
price fixing in Europe, difficulties-----	191-194
statistics, miscellaneous-----	722-755
Agriculture—	
American progress, discussion by Secretary-----	17-25
Department—	
number of employees and funds expended-----	55
organization, March 1, 1920-----	3
history and geography, project of Farm Management Office work-----	37, 38
State officials in charge-----	500
study in country schools, requirements-----	295-297
Alabama—	
cattle, Federal inspection for tuberculosis, number, and address of inspector-----	286
marketing, cooperative, work of county agents and results-----	214-217
nitrate plants, building and possible output-----	120
Alfalfa—	
hay price, 1915-1919-----	584
seed, labeling with origin-----	344
Algeria, farm animals, number and kinds, 1888-1912-----	644
Almonds, imports statistics-----	687, 702
Ammonium—	
nitrate, production, Muscle Shoals plant, Alabama-----	120
sulphate, recovery from coke ovens-----	116, 121
Animals—	
and animal products, international trade, by countries-----	648-652
contagious diseases, progress in eradication, article by John R. Mohler-----	69-78
fur-bearing—	
skinning directions-----	477
trapping directions-----	457-476
live—	
exports statistics-----	691, 699, 710
imports statistics-----	682, 699, 716
meat, prices, index numbers, 1910-1919-----	742
wild, destruction by bad practices, and reduced fur supply-----	482
<i>See also Live stock.</i>	

	Page.
Anthrax, prevention, note.....	77
Appendix.....	497-755
Apples—	
exports statistics.....	694, 701, 712
growers, benefit of market-news reports.....	111-112
market reports, study.....	107
prices—	
by States, 1918, 1919.....	601-602
in market season, 1918-1919.....	110
on farm.....	602
production, estimates, 1916-1919.....	603
statistics, production and prices, by States.....	601-604
varieties, production, United States and by States.....	604
Appropriations, farm management, remarks.....	38
Apricots, exports statistics.....	712
Arc process, nitrogen fixation.....	117-118
Argentina—	
demand for breeding stock.....	379-380
farm animals, number and kinds.....	644
live stock—	
industry, conditions and outlook.....	377-380
prewar and postwar estimates, and per cent change.....	423-424
market for American live stock, outlook, considerations, etc.....	377-380
Argentine Rural Society, relation to live-stock industry, work and importance.....	377-379
Argols, imports statistics.....	684, 699, 702
Arithmetic, study in country schools, requirements.....	294
Arkansas, cattle, Federal inspection for tuberculosis, number, and address of inspector.....	286
ARNOLD, J. H., and R. R. SPAFFORD, article on "Farm practices in growing wheat".....	123-150
Asparagus, acreage and production, 1917, 1918.....	621
Asses, numbers, by countries.....	644-648
Associations—	
cooperative purchasing, organization and plan of operation.....	385-390
incorporated, operation.....	385, 386
live stock, with officials.....	502-508
Australia—	
farm animals, number and kinds, 1890-1919.....	644
live stock, prewar and postwar estimates and per cent change.....	423-424
Austria-Hungary—	
farm animals, number and kinds, 1880-1910.....	644
tobacco production, percentage of world crop.....	156
Bait, preparation for trapping animals.....	467, 468
Bakken prairie-dog set, use for trapping wolves.....	468, 469
Baltimore, market station, lines of work.....	96, 101, 111
Bananas, imports statistics.....	686, 719
Bank, order and payment forms for purchasing associations.....	389
Banks, cooperation in live-stock drought relief work.....	404
Barley—	
acreage—	
and production, by countries, 1909-1919.....	539-541
and production, by States.....	543
consumption, total and per capita, by countries, 1914-1918.....	566
exports—	
1867-1919.....	542
statistics.....	694
imports, 1866-1908.....	542
prices, by States and by months, 1910-1919.....	544-545
production, by countries, 1909-1918.....	564, 566
statistics, acreage, yield, prices, etc.....	539-546, 642
trade, international.....	546
yield per acre, by States.....	544
yields, changes since 1876.....	20, 23
Barn, thrashing of wheat.....	147
Basement. <i>See</i> Cellar.	

	Page.
Beans—	
acreage—	
and production, 1917, 1918	621
production, prices, and value	613-616
dry, acreage, production, etc., 1914-1919	614
exports statistics	697
imports statistics	690
prices, farm and wholesale	615
seed, labeling with origin	344
statistics, acreage, yield, value, etc.	613-616, 690, 697
world crop, statistics	613-616
Beaver, skins, drying directions	476, 477
Beavers—	
numbers, distribution, and habits	452, 476
trapping directions	476
Beef—	
cattle, limited prewar supply, and cause	341
exports statistics	691, 700, 710
Beeswax—	
exports statistics	691
imports statistics	682, 704
Beet sugar. <i>See</i> Sugar.	
Beetles, larder, injuries to skins, and control	481
Beets—	
acreage, yield and sucrose content, by States	627
price per ton, by States, 1913-1919	626
sugar, seed imports statistics	689
Belgium—	
crop yields, comparison with United States	24, 25
farm animals, numbers and kinds, 1880-1913	644
live stock—	
condition of industry and outlook	411-412
prewar and postwar estimates and per cent change	423-424
BELL, GEORGE A., and TURNER WRIGHT, bulletin on "Live stock conditions in Europe"	407-424
"Better Sires" campaign—	
enrollment of first three months	353-354
object, origin, and progress, article by D. S. Burch	347-354
Big Bend, Tex., pink bollworm infestation and control work	364, 365
Billings, Mont., live-stock emergency office, establishment	394
Binders, use in wheat harvesting	143-144
Binding, Yearbook, law authorization	2
Blackleg, preventive measures	77
Bobcats, trapping directions	463-464
Boll weevil, introduction, spread, and damages to cotton crop	355
Bollworm, pink—	
control—	
future work	368
in United States, article by W. D. Hunter	355-368
inspection work—	
and scouting, 1919. results	365-367
Mexican border ports	359
longevity and injuries to cotton	356, 367
Texas control work, methods	362, 367-368
Bonds, road, State issues, remarks by Secretary	50
Bosnia-Herzegovina, farm animals, number and kinds, 1895-1910	644
Boston, market station, lines of work	96, 107, 111
Bovine tuberculosis, eradication in District of Columbia	73
Box trap—	
use for catching muskrats	475
use for catching small animals	454-455, 458-459
Boys, country, educational needs	291-293
Brazil—	
aid to importers of pure-bred live stock	371-372
farm animals, numbers and kinds, 1912-1916	644
live-stock industry, conditions	371-372
market for American pure-bred live stock, studies	371-374
tobacco production, percentage of world crop and trade	156, 160



	Page.
Bread grains, Germany, production 1911-1919	62
Broadcasting wheat, practices	141-143
Broom corn—	
acreage, production, and value, by States, 1915-1919	618
exports, statistics	692
prices on farm, 1910-1919	618
statistics, acreage, production, and value, 1915-1919	618
BROWN, EDGAR, article on "What the farmer should expect from the seedsman."	343-346
Buckwheat—	
acreage and production, by States, 1919	555
price per bushel, by States and by months, 1910-1919	556
statistics, acreage, production, prices, etc.	554-556
yield per acre, by States, 1910-1919	556
Bud—	
selection—	
citrus fruits, results and economic value	271-273
value in control of fruit variation	259-260
effect on citrus yield and quality in California	250-261
variation occurrence in California citrus groves, investigations	250-261
Bud wood—	
citrus—	
fruit-bearing, selection	267-268
handling, cost, and uses	268-271
selection and distribution, methods	265-275
Buds, citrus, distribution and use	270-271
Buffaloes, numbers by countries	644-648
Building sites, selection	425-427
Buildings, rural school, equipment	299-301
Bulgaria, farm animals, numbers and kinds 1892-1910	644
Bund der Landwirte, organization, and influence on crop estimates in Germany	61-62
BURCH, D. S., article on "Harnessing heredity to improve nation's live stock."	347-354
BUSCK, AUGUST, pink bollworm investigations, note	367
Butter—	
exports statistics	691, 710
international trade, by countries, 1909-1913, 1917, 1918	663
market receipts, 1891-1919	663
prices—	
at principal markets, by months, 1913-1919	661
on farm, by States	662
statistics	661-664
Cabbage—	
acreage, yield, and production 1915-1919, by States	621
prices—	
by months, 1910-1919	622
in market season, 1918-1919	110
California—	
citrus—	
industry, development, importance, and causes	250
yield and quality studies	250-261
Fruit Growers' Exchange, value to citrus industry	275
Calves—	
lymphangitis, symptoms and mortality	72
prices by months, 1910-1919	661
Camphor, crude, imports statistics	685, 706
Canada—	
farm animals, numbers and kinds, 1881-1918	645
live stock, prewar and postwar estimates, and per cent change	423-424
Cane, acreage, and production, by States	628
Canned vegetables, exports statistics	697
Cantaloupes, acreage and production, 1917, 1918	621
CARNEY, MABEL, statement on advantages of consolidation of country schools	305-306
Casing, skins of small animals	477-479

	Page.
Castor—	
beans, imports statistics	689
beaver, uses by trappers and perfume makers	476
Cat trap, for catching vagrant cats, details of construction	456, 458, 459
Cats, catching in box traps	456, 458-459
Cattle—	
Argentina, prewar and postwar estimates and per cent change	423
Australia, prewar and postwar estimates and per cent change	423
Canada, prewar and postwar estimates and per cent change	423
carcasses condemned as tuberculous, 1917-1919	279
European countries, prewar and postwar estimates and per cent change	423
exhibits at live-stock shows in Uruguay, practices and prices	375
exports statistics	691, 700, 710
farcy, occurrence and fatality	72-75
France, effect of war and outlook	409-411
hides, imports statistics	683, 704, 718
imports—	
exports and prices, 1893-1919	657
statistics	682, 716
loss from tuberculosis	277-288
market prices, by months, 1913-1919	660
marketings, 1900-1919	679
New Zealand, prewar and postwar estimates and per cent change	423
number—	
and farm value, 1867-1920	658
and farm value, by States, 1919, 1920	659
numbers by countries	644-648
plague, nature, occurrence and fatality	76-77
pleuropneumonia, extent and eradication	70, 76
prewar and postwar estimates and per cent change in United States	423
pure-bred, selling to South America, considerations and outlook	369-380
rinderpest, nature, occurrence, and fatality	76-77
scabies, eradication work	71, 77-78
statistics	658-661, 678-679, 682, 691, 700, 710, 716
Switzerland, effect of war on industry	413-414
ticks, suppression, chart	74
tuberculosis—	
eradication cooperative work chart	74
eradication in District of Columbia	73
inspection, number under Federal supervision, by States	286-287
tuberculosis-free, premiums in trade, practices	284-285
Cauliflower, acreage and production, 1917, 1918	621
Celery, acreage and production, 1917, 1918	621
Cellar—	
damp—	
causes and remedies	427-449
harmful effects	425
damp-proofing, treatment of walls and floor	428-449
drain zone around building, construction and advantages	428-430
drainage, types and management	439-446
dry—	
advantages	425
securing, article by George M. Warren	425-449
Census, reports on tobacco, 1839-1909, increase of crop	152
Cereals—	
consumption, total and per capita, by countries	564-567
exports in 1910-1919	11-12, 15
production by countries, 1914-1918	566-567
<i>See also</i> Grain.	
Charolais cattle, breeding work in France, note	411
Cheese—	
exports statistics	691, 700
imports statistics	682, 702-703, 716
statistics	666-667
Switzerland, effect of war on industry	413
trade, international, by countries, 1909-1913, 1917, 1918	666-667

	Page.
Cheroots, import duties, and internal revenue tax	170, 171
Chicago—	
market station, lines of work	96, 104-105, 107
meat-packing interests, control of trade	340-341
Chickens—	
keeping, article	307-317
prices on farm, by States, 1909-1917	667-668
statistics	667-668
Chicks—	
brooding and feeding methods	315
hatching, timeliness	314-315
management and care	315-316
protection against lice and mice, methods	316
Chile, nitrate beds as source of nitrogen fertilizer	116
Cholera, hog—	
control work	198-199
fake remedies	202-204
practical points in control, article by T. P. White	197-204
sources of infection	199-202
Cigarettes—	
import duties and internal revenue tax	170, 171
use, increase, and number made	165-166, 174
Cigars—	
import duties and internal revenue tax	170, 171
manufacture, output, exports, etc	173-174
tobacco types, locations where grown	152-153
Cinchona bark, imports statistics	684
Cincinnati, market station, lines of work	96
Cities, market possibilities in various lines	110-111
Citrus—	
fruits, importance of California varieties, article by A. D. Shamel	249-275
industry, California, development, importance, and cause	250
stock, cooperation in securing reliable trees	271
strains—	
comparative value	260-261
origin and definition of term	253
trees, record-kept, picking methods	262-264
varieties—	
cooperative improvement	275
variation investigations in California, note	253
<i>See also</i> Fruits, citrus.	
Civet cat. <i>See</i> Skunk.	
Civics, study in country schools, requirements	294
Cleaner, electric vacuum, types and value in home	329
Cleveland, market station, lines of work	96, 101
Clover seed—	
acreage, production, price, and farm value	586-588
exports statistics	696
imports statistics	689, 720
labeling with origin	344
Clubs, buying, operation	386
Coal, source of ammonia for fertilizers	116
COBBS, JOHN L. JR., article on "The open road through the National Forest"	177-188
Cocoa—	
exports statistics	692, 699
imports statistics	684, 699, 702, 718
Coconut meat, imports statistics	687
Coffee—	
exports statistics	639, 692, 699
imports statistics	639, 684, 699, 702, 719
prices, New York and New Orleans, by months, 1913-1919	640
trade, international	639
Coke ovens, ammonium sulphate recovery	116, 121

	Page.
Colleges—	
agricultural—	
buildings, incomes, students, etc., 1918	55
cooperation in live-stock drought relief work	404
list, location, and presidents	497-499
scope, tuition charges, etc	497
Colorado, cattle, Federal inspection for tuberculosis, number, and address of inspector	286
Concrete—	
formula and preparation for waterproofing cellar	443-446
reinforcement for cellar floors	445
use for—	
cellar floor, requirements	431-432
damp-proofing cellars	429-434, 435
Connecticut—	
cattle, Federal inspection for tuberculosis, number, and address of inspector	286
tobacco production, rank, 1914-1918	154
Cooking, electric, advantages and practices	234-238
Cooperation—	
farmers' associations' encouragement	44-45
importance to citrus growers	275
market stations with State marketing agents	97
purchasing, possibilities and limitations	382-385
States, in reports on crops and live stock	41
value in live-stock drought relief work	403-405
Cork wood, imports statistics	684, 699
Corn—	
acreage and production, by countries, 1909-1919	509-510
consumption, total and per capita, by countries	565, 566
crop estimate for 1919	11
exports—	
1849-1919	510-511
statistics	694, 701, 713
imports statistics	686
market price per bushel, 1913-1919	515
marketing, cooperative profits, instance	211
marketings, by months, 1914-1919	516
prices by States, 1866-1919	510-522, 514-516
production by countries, 1909-1918	565, 566
statistics, acreage, yield, prices, etc	509-517
supplies, old stock, production and quality	513
sweet, acreage and production, 1917, 1918	621
trade, international	517
yield and farm price by States, 1910-1919	514, 516
yields, changes since 1876	19, 22, 23
Cotton—	
acreage, production, value, exports, etc	589-594
baled, disinfection at ports of entry	356-357
destruction, compensation to owners	360-361
exports—	
1866-1919	590
and imports	594
statistics	692, 699, 701, 712
fields, clean-up work in pink bollworm campaign	362, 367-368
growing restrictions, Trinity Bay section and Pecos Valley, Tex	363-367
imports—	
and exports	594
statistics	684, 699, 719
injuries by pink bollworm	356
lint production, 1910-1919	591
Mexican, spread of pink bollworm in Texas	359
outlaw crop, disposal of	363
pests, successive introduction	355
prices, farm and wholesale, 1909-1919	592-593
quarantine on account of pink bollworm	357

	Page.
Cotton—Continued.	
statistics, acreage, production, yield, prices, value, etc.....	589-594
Texas, inspection in fields in 1918, results.....	364
world crop, statistics.....	589-594
yield per acre, 1910-1919.....	592
yields, changes since 1876.....	21, 22, 23
zones, restricted growing, management.....	363-367
Cottonseed—	
cake and meal, exports statistics.....	696, 701, 714
exports statistics.....	696
infested with pink bollworm, disposal of.....	359, 362
meal, freight rates to Montana and Wyoming.....	396
Mexico, admission restrictions.....	357-359
oil—	
exports statistics.....	595, 696, 702, 714
imports statistics.....	595, 688
production, value, and farm prices, by States, 1910-1919.....	594-595
quarantine on account of pink bollworm.....	357
County estimates, value to extension workers.....	40, 41
Cowpeas—	
acreage, production, and value, 1917-1919.....	616-617
prices, farm value, etc.....	616-617
statistics, acreage, production, and value.....	616-617
Cows—	
milk, prices on farm by months, 1910-1919.....	661
prices—	
in Belgium.....	412
in France.....	410
in Netherlands.....	417
in Switzerland.....	414
Coyotes, trapping directions.....	468-470
Cradle, use in harvesting wheat.....	146
Cranberries—	
acreage, production, prices, etc.....	609
prices, farm value, etc.....	609
statistics, production, and value.....	609
Croatia-Slavonia, farm animals, number and kind 1895, 1911.....	644
Crop—	
Estimates Bureau, work review.....	39-43
estimates, prewar, in Germany, article by Alonzo Englebert Taylor.....	61-68
prices, index numbers, monthly and average, 1910-1919.....	736
reporting, Germany, communal system.....	61-62, 64-65
summary, 1918, 1919, and average, 1913-1917.....	722-723
yields—	
per acre and per man, American and foreign, comparison.....	24-25
per acre, increase since 1876.....	17-24
Crops—	
acreage—	
and production, discussion and tables, 1914-1919.....	10-11, 12, 13
by States, 1909-1919.....	726-727
increase during war.....	10, 28
average yield, by States, 1910-1919.....	728-729
composite conditions, monthly, 1910-1919.....	729
feed—	
consumption on farms, monthly.....	730
disposition on farms.....	729
Germany, prewar estimates, article by Alonzo Englebert Taylor.....	61-68
harvesting time, by months.....	727-728
productivity of various countries, index figures.....	735
reporting service enlargement, importance.....	40
sales time of farmers for principal staples, by months and States.....	730-732
staple, leading States, 1917-1919.....	724
statistics—	
acreage, production, and exports, 1914-1919.....	12, 13, 15
miscellaneous.....	722-723
other than grain.....	568-643
value, per acre.....	725

	Page.
Crops—Continued.	
values, 1910-1919	17
values, comparison by States, 1909-1913	725-726
world production, and export trade, 1909-1913	735
yields, by States, 1910-1919	728-729
yields in foreign countries, increase	24
Crossbred stock, definition	349
Crows, trapping directions	456
Cuba, tobacco exports to United States	161
Cucumbers, acreage and production, 1917, 1918	621
Cultivators, use in wheat growing	132
Currants, imports statistics	686, 704
Customs—	
duties on tobacco	169-171, 172, 173
receipts from tobacco	172
Cyanamid—	
process, nitrogen fixation	119
use as fertilizer, or conversion into other fertilizers	119, 121
Cyanide process, nitrogen fixation	118-119
Dairy—	
cows, improvement by use of pure-bred sires	352
products—	
exports statistics	691, 699
imports statistics	682, 699, 716
production and exports, 1910-1919	11-12, 14-15, 28
Damp-proofing, cellar, management	431-432
DANIELS, A. M., article on "Electric light and power in the farm home"	223-238
Dates, imports statistics	686, 704
DAVIS, R. O. E., article on "Atmospheric nitrogen for fertilizers"	115-121
DEARBORN, NED, article on "Trapping on the farm"	451-484
Delaware, cattle, Federal inspection for tuberculosis, number, and address of inspector	286
Demonstration activities, project of Farm Management Office work	37, 38
Demonstrations, marketing and purchasing, in the South, article by Bradford Knapp	205-222
Denmark—	
farm animals, numbers and kinds, 1898-1919	645
live stock, prewar and postwar estimates and per cent change	423-424
Denver, market station, lines of work	96, 107
Department of Agriculture. <i>See</i> Agriculture.	
DILLE, ALVIN, article on "The reorganization of the country school"	289-306
Diseases, contagious animal, progress in eradication, article by John R. Mohler	69-78
Disinfection, cotton at ports of entry	357
Disk plow, use in wheat growing	128, 129, 131, 135-136, 143
Distribution, farm products, problems	43-45
Ditches, drainage, cost of cutting with community-owned machinery	86-87
Ditching companies, community drainage work, prices, etc	80-86
Dourine, nature and occurrence	77
Drag, plank, use in wheat growing	129-130, 134, 135
Drainage—	
cellar, types and management	439-446
crew, work in community tile drainage construction	91-92
tile—	
community construction, article by John R. Haswell	79-93
cost of construction by machinery	86-88
value, profits from, etc	92-93
Drains, cellar, location and construction	434-437
Drilling, wheat—	
in standing corn	138-139
into stubble	128, 135-137, 138, 148
practices	141-143
Drought—	
live-stock relief work in 1919, article by George M. Rommel	391-405
Northwest, area and States affected	398
Drying, skins of fur animals	460, 461, 462, 463, 465, 467, 470, 474, 475, 476, 477-481

	Page.
Dutch East Indies, tobacco production, percentage of world crop and trade	156, 159
Duties, import, on tobacco, laws and changes	169-170
Dyewoods, imports statistics	684, 699
Eastern area, wheat growing, climate and conditions	126, 143, 147
Economics, home, study in country schools, requirements	297-298
Education—	
redirection in country schools, discussion	293-299
reorganization of country schools, article by Alvin Dille	289-306
Eggs—	
exports statistics	691, 699
imports statistics	682, 699
infertile, desirability and profits	316-317
marketing—	
management	218-219
time and methods	316-317
prices—	
at principal markets, by months, 1913-1919	664
on farm, by States, 1909-1918	665
production in 1919, forecast and statistics	11, 14, 28
statistics	664-666, 682, 691, 699
Egypt, farm animals, numbers and kinds, 1890-1916	645
Electric—	
light and power, farm home, article by A. M. Daniels	223-238
motor, portable utility, description and uses in the home	225-227
Electricity—	
use and value in the farm home	223-238
use in nitrogen fixation	117-118
value in the home	223-224
Electric-lighting appliances for the home	235-238
Engineering, electrical, for farm home	223-238
Ermine furs, making from white weasels	461
ERNEST, L. B., and J. A. KIERNAN, article on "The toll of tuberculosis in live stock"	277-288
Europe—	
agricultural production, regulative influences	189-190
food shortage at close of war	9-10
live stock—	
conditions, article by Turner Wright and George A. Bell	407-424
shortage	9
European countries, crop yields increase	24-25
Exchange—	
depreciation, influence on agricultural production, article by Alonzo Englebert Taylor	189-196
marketing lists	44
Experiment station workers, Southern, resolutions on lime production, use, and value	340-341
Experiment stations, agricultural, list, location, and directors	499-500
Exports—	
agricultural products, 1910-1919	11-12, 14-16
agricultural products, statistics	510-511, 520, 533, 542, 549, 576, 590, 594, 595, 601, 613, 620, 630, 637, 639, 641, 642, 643, 691-702, 705, 708, 710-715
cattle, 1893-1919	657
farm products, 1852-1919	700-702
foodstuffs, 1913-1919	736
horses and mules, 1893-1919	657
sheep, 1893-1919	670
tobacco—	
colonial history	152
countries of consignment, and world's trade	158-160
world crops, 1909-1913	735
Exposition, Palermo, Argentina, live-stock show	373, 377-379

	Page.
Extension—	
Act, object and funds expended	56
work—	
cooperative agricultural, State officials	500-501
marketing and purchasing demonstrations in the South	205-222
workers, assistance of market specialists	45, 57
Farcy, cattle, occurrence, symptoms, and fatality	73-75
Farm—	
animals, number, value, classes, and losses from poor breeding	348, 353
<i>See also</i> Live stock.	
area, expansion of, discussion by Secretary	25-27
crops—	
productivity, index figures, by countries	735
selling time, by months and by States	730-732
value per acre	725
world production, and export trade, 1909-1913	735
financial relations, project of Farm Management Office work	37, 38
home, electric light and power, article by A. M. Daniels	223-238
income, average, 1910-1918	740
labor—	
hiring methods	740
income, 1910-1918	740
wages by classes and States, 1910-1919	738-739
lands, problems, increased area, settlement, and tenancy	25-32
life—	
improved conditions, schools, roads, etc., importance	28
studies, project of Farm Management Office work	37, 38
Loan Act, object and results, remarks by Secretary	57
loans, Federal system, benefit to purchasers of farms	32
Management Bureau, proposed organization and estimates	35-38
management—	
study committee, personnel and report	35
with farm economics, studies and work	35-39
produce—	
carload shipments, receivers' complaints, and causes	319-320
inspection certificate, scope and value	320-321
inspection, why it pays, article by H. E. Kramer and G. B. Fiske	319-334
kinds and amount inspected, 1918-1919	323-324
products—	
exports—	
selected list, 1852-1919	700-702
to specified countries, 1917-1919, statistics	709
foreign trade, 1852-1919	698
groups, exports and imports, values, 1917-1919	699-700
imports from specified countries, 1917-1919, statistics	707
imports, selected list, 1852-1919	702-704
marketing and distribution, problems	43-45
marketing demonstrations in the South	206-220
surplus, reports, importance	40, 44
values estimated on farm prices, 1879-1919	724
sales, receipts from	733
tenancy, need of improved methods of leasing, etc.	30-32
tractors in United States, statistics	745-746
trapping fur animals and preparing skins	451-484
Farmers—	
American, food supply to Europe	9-10
cooperative—	
associations, encouragement	44-45
marketing and purchasing, demonstrations in the South	205-222
harvesting time for crops, by months	727-728
interest in protection of private forests	33, 34
marketing—	
associations, cooperative, in the South, work and value	211-220
work, aid of market specialists	45



	Page.
Farmers—Continued.	
prices for articles bought, 1909-1919	736-738
purchasing organizations, article by J. M. Mehl	381-390
rights in relation to the seedsman, article by Edgar Brown	343-346
selling time for crops, by months and States	730-732
Farms, practices in growing wheat	123-150
Federal—	
Government, income from tobacco	172-173
Highway Commission, discussion	50-54
Inspection Service, establishment, scope, and value	320
Meat Inspection, establishments, condemnations of animals, etc	679-681
Reserve Act, objects	57
Feed—	
crops—	
consumption on farms monthly	730
disposition on farms	729
emergency purchase, cooperative work in Texas	220-221
oil cake and oil-cake meal, trade, international	641
shortage in European countries	410, 412, 413, 417
supply reports, importance to live-stock interests	43
Feeding hens, feed and method	313-314
Feeds—	
emergency rates for drought sufferers	396, 403
purchasing, advantages of cooperative associations	382, 384
Feedstuffs, consumption on farms, monthly	730
Fertilizers—	
atmospheric nitrogen, article by R. O. E. Davis	115-121
purchasing advantages of cooperative associations	382, 384
Fibers—	
animal—	
exports statistics	691, 699
imports statistics	682, 699, 717
vegetable, imports, statistics	684, 699, 719
Figs, imports, statistics	686, 704
Filing, market news reports and special articles	112-113
Filler tobacco, import duty	169
Finland, farm animals, numbers and kinds, 1890-1910	645
Fire, protection of private forests, importance to farmers	33, 34
FISKE, G. B.—	
and H. E. KRAMER, article on "Why produce inspection pays"	319-334
article on "How to use market stations"	94-114
Flax—	
acreage and production by countries, 1909-1918	557-558
imports, statistics	684, 703, 719
price per bushel by States and by months, 1910-1919	559-560
statistics, acreage, yield, prices, etc	557-560
Flaxseed—	
imports, statistics	689, 720
marketing by months, 1914-1919	560
seed, price per bushel by States and by months, 1910-1919	559-560
statistics, acreage, yield, prices, etc	559-560
yield per acre by States, 1910-1919	559
Fleshing skins, directions	478
FLETCHER, C. C., article on "Home production of lime by the farmer"	335-341
Floor, cellar, treatment with cement	431-432
Florida, cattle, Federal inspection for tuberculosis, number, and address of inspector	286
Flour—	
consumption per capita in Germany, note	65
wheat, price per barrel by months, 1913-1919	529
Food—	
Control Act, provision for supervision of trade in live stock	241-243
demands of Europe met by America	9, 10
shortage in Europe	9, 10
Foodstuffs, foreign trade, 1913-1919	736

	Page.
Foot-and-mouth-disease—	
outbreak in Italy, damage to cattle industry	414-415
suppression work, chart	75
symptoms and occurrence	72
Foreign—	
countries, crop yields increase	24
estimates, crops and live stock	41
Forest—	
lands, acquisition under Weeks forestry law	34
products—	
exports, 1852-1919	705
exports statistics	692-694, 699-700, 705, 715
foreign trade 1852-1919	705, 706
imports statistics	684-686, 699-700, 706, 721
Service, cooperation in live-stock drought relief	392
Forestry, extension, importance to private owners	32-35
Forests, National—	
area of lands by States, 1919	750-752
grazing—	
allowances, 1919	753-755
permits, kinds of stock, etc., 1915-1919	750
location in two or more States	752
need of roads, relation to work of Forest Service	177-180
open road through, article by John L. Cobbs, jr	177-188
receipts from, use in road construction	180
roads, appropriations and progress of work	46, 49
statistics	749-755
timber disposal, prices, etc., 1915-1919	749, 750
water power permits, 1915-1919	750
Formosa, farm animals, numbers and kinds, 1905-1916	646
Fox skins, casing directions	467
Foxes—	
trapping directions	465-467
types and habits	451, 465, 467
France—	
agricultural production, influence of depreciation of exchange	190-191
crop—	
estimates, 1880-1913, note	66
yields, comparison with United States	24, 25
farm animals, numbers and kinds, 1862-1918	645
live stock—	
conditions	408-411
prewar and postwar, and per cent change	423-424
Freight—	
rates, feed and live stock, emergency shipments	396, 403
tonnage, 1915-1918	745
Fruit Growers' Exchange, California, distribution of bud wood, selection methods, etc	265-275
Fruits—	
citrus—	
importance of California varieties, article by A. D. Shamel	249-275
shipments from California, 1918-1919, and value	249
exports statistics	694, 699, 712
imports statistics	686, 699, 704, 719
inspection by Department agents	44
marketing, profits, etc., instance	218
statistics, production in 1910-1919	13
<i>See also Apples; Apricots; Citrus; Figs; Grapes; Oranges; Peaches; Pears; Prunes.</i>	
Fumigating houses, erection on Mexican border	359
Fumigation, freight and vehicles, Mexican border ports	359
Fur—	
animals, trapping directions	457-476
bearers, destruction by bad practices	482
farming possibilities	483
supply, increase and improvement	482-484
154887°—YBK 1919—49	

	Page.
Furs—	
cleaning-----	479, 480-481
packing-----	479
Garbage, source of hog-cholera infection-----	199-200
Geography, study in country schools, requirements-----	295
Georgia, cattle, Federal inspection for tuberculosis, number, and address of inspector-----	286
Germany—	
agricultural production, influence of depreciation of exchange-----	191
crop estimates, political significance-----	61-62
crops—	
discrepancies in prewar estimates-----	61-68
exaggeration of estimates, methods and purpose-----	61-64
farm animals, numbers and kind, 1883-1918-----	645
live stock, prewar and postwar estimates, and per cent change-----	423-424
nitrate production from artificial sources-----	116, 119
potato crops, prewar estimates-----	67-68
prewar crop estimates, article by Alonzo Englebert Taylor-----	61-68
tobacco production, percentage of world crop-----	156
Ginseng, exports statistics-----	694, 699
Girls, country, educational needs-----	291-293
Glanders, preventive measures-----	77
Glucose, exports statistics-----	694, 699, 701, 713
Glue—	
exports statistics-----	691
imports statistics-----	683
Goats—	
Malta fever, eradication work-----	75-76
numbers, by countries-----	644-648
Goatskins, imports statistics-----	683, 704, 718
Gopher, pocket, trapping, methods and directions-----	455-456
Grade stock, definition-----	349
Grading up, live stock, principles-----	348
Grain—	
consumption—	
total and per capita, by countries-----	564-567
total and per capita, by countries, 1914-1918-----	566-567
crops, statistics, 1919-----	509-567
exports statistics-----	694, 699, 713
imports statistics-----	686, 699
growers, European, influence of depreciation of exchange-----	191-196
Standards Act, objects, remarks by Secretary-----	56
Grains, bread, production in Germany 1911-1919-----	62
Grapefruit—	
Marsh variety, production in California-----	249-250
shipments from California, 1918-1919, and value-----	249-250
Grapes, imports statistics-----	686
Grass seed, exports statistics-----	696
Grazing—	
allowances—	
for National Forests, by districts, 1919-----	753-755
in National Forests, 1915-1919-----	750
lands, listing for drought sufferers-----	394
National Forests, number of stock, and rates, by districts, 1919-----	753-755
Great Plains area, wheat-growing conditions and practices-----	126, 134, 140, 143, 144, 148, 149, 150
Greece, farm animals, numbers and kinds, 1914-----	645
Gums, imports statistics-----	685, 699, 721
Haber process, nitrogen fixation-----	120
HALL, L. D., member of committee on live-stock drought relief-----	391
HALL, LOUIS D., article on "Federal supervision of live stock markets"-----	239-248
HARRELL, DAVID, and H. P. MORGAN, article on "Selling pure-bred stock to South America"-----	369-380
HARROW, use in wheat growing-----	128, 129, 131, 143
Harvester and thresher combine, use in wheat harvesting-----	145-146
Harvesting, wheat, methods-----	143-146
HASWELL, JOHN R., article on "Community tile drainage construction"-----	79-93

	Page.
Hawaii—	
cane-sugar production, 1913-1919	629
cottonseed exclusion from United States	357
shipments—	
from the United States, 1917-1919	709
to the United States, 1917-1919	709
Hawks, trapping	457
Hay—	
acreage production, value, exports, etc., 1849-1919	580-585
exports statistics	695, 699
imports statistics	687, 699
prices, farm and wholesale	583-584
statistics, acreage, production, yield, values, exports, etc	580-585
wild, salt, and prairie, acreage, production, and farm value, 1909-1919	585
yield, price, and acre value, by States	582
yields, changes since 1876	20, 22, 23
Headers, use in wheat harvesting	144-145
Health, study in country schools, requirements	295
Heating—	
pad, electrical, value, note	237
plant, electric, for farm home, requirements	228-230
Hemp, imports statistics	684, 703
Hens—	
feeding methods and feeds	313-314
housing essentials, space required, etc	312
profit possibilities on farms, suggestions	317
selection of breeding stock, value of culling, etc	310-311
size of farm flock, effect on profits, etc	311-312
Herd, accredited, plan for eradication of tuberculosis, advantages	279
Herds, tuberculosis inspection, number under Federal supervision, by States	286-287
Heredity, principles, use in improvement of live stock	347-354
Hides—	
exports statistics	691
imports statistics	683, 704, 717-718
trade, international, by countries, 1909-1913, 1917, 1918	648-649
<i>See also</i> Skins.	
Highway Officials, American Association, advisory work	48
Highways. <i>See</i> Roads.	
History, study in country schools, requirements	294
Hog cholera. <i>See</i> Cholera, hog.	
Hogs—	
carcasses condemned as tuberculous, 1917-1919	279
cholera—	
control, practical points, article by T. P. White	197-204
infected, condemnations at inspection stations, 1914-1919	198
dead from cholera, disposal	201
foot-and-mouth disease, symptoms and occurrence	72
France, effect of war on industry and outlook	409-410
imports statistics	682
loss from tuberculosis in one shipment, instance	281-282
losses from cholera 1918	202
marketing, profits, etc., instances	211, 212-214, 215-216
marketings, 1900-1919	679
number—	
and value on farms, by States, 1919, 1920	676
and value on farms, Jan. 1, 1919	197
prices and farm value, 1867-1920	675
numbers by countries	644-648
prewar supply and cause	341
shipping from stockyards to farm, spread of cholera	200
statistics	675-677, 679
stocker, spread of cholera	200
tuberculosis, eradication, suggestions	288
HOLMES, GEORGE K., article on "Three centuries of tobacco"	151-175

	Page.
Home—	
economics, study in country schools, requirements	297-298
farm, electric light and power, article by A. M. Daniels	223-238
Honey—	
exports statistics	691
imports statistics	683
Honolulu, pink bollworm, records of longevity, etc	356, 367
Hops—	
consumption and movement, 1910-1919	610
exports, 1910-1919	610, 613
exports statistics	695, 699, 702, 713
imports, 1910-1919	610, 613
imports statistics	687, 699, 703
prices, farm, and wholesale	610-612
statistics, acreage, production, value, exports, etc	609-613
world crop, statistics	609-613
Horse—	
day, average, misleading character of reckoning	491-492
power on farm problem, article by Oscar A. Juve	485-494
sickness, African, symptoms, occurrence and fatality	72
Horses—	
Australia, prewar and postwar estimates and per cent change	424
Belgium, effect of war on industry	411-412
Canada, prewar and postwar estimates and per cent change	424
European countries, prewar and postwar estimates and per cent change	424
exports statistics	691, 710
imports statistics	682, 716
lymphangitis, symptoms, occurrence and mortality	73
mal de Caderas, symptoms, occurrence and mortality	72-73
New Zealand, prewar and postwar estimates and per cent change	424
number—	
and value on farms, 1867-1920	653
and value on farms by States, 1910, 1919	654
received at live-stock markets (with mules), 1900-1919	656
numbers, by countries	644-648
Percheron stock in France, effect of war and outlook	408-409
prewar and postwar estimates and per cent change in United States	424
prices at principal markets	655-656
statistics	653-657, 678-679
surra, nature, occurrence and fatality	77
team use, variations in numbers of horses in team	491-492
HOUSTON, D. F., report as Secretary of Agriculture, 1919	9-59
HUNTER, W. D., article on "The fight against the pink bollworm in the United States"	355-368
Hygiene, study in country schools, requirements	295
Idaho, cattle, Federal inspection for tuberculosis, number, and address of inspector	286
Illinois, cattle, Federal inspection for tuberculosis, number, and address of inspector	286
Illiterates, percentage in rural districts	289
Imports—	
Agricultural products, statistics	576, 594, 595, 601, 613, 630, 637, 639, 641, 642, 643, 682, 690, 698-700, 702-704, 706-707, 716-721
cattle, 1893-1919	657
duties on tobacco, history	169-171, 172, 173
farm products, selected list, 1852-1919	702-704
foodstuffs, 1913-1919	736
horses, 1893-1919	657
sheep, 1893-1919	670
India—	
farm animals, numbers and kinds, 1900-1917	645
rubber—	
imports statistics	685, 699, 706, 721
trade, international	642

	Page.
Indiana, cattle, Federal inspection by, for tuberculosis, number, and address of inspector-----	286
Indigo, imports statistics-----	687, 699
Insects, injuries to furs, control-----	481
Inspection—	
certificates, samples-----	328-330
cotton fields, Texas, for pink bollworm-----	362, 367
farm produce—	
kinds and quantity inspected, 1918-1919-----	323-324
why it pays, article by H. E. Kramer and G. B. Fiske-----	319-334
Federal, of farm produce, results of two years' work-----	331-332
freight and baggage, Mexican border ports-----	359
fruits and vegetables-----	44
markets, location, by States-----	333-334
produce—	
practical suggestions-----	322-323
relation to deception decrease-----	328-330
Texas cotton fields, 1918 and 1919, results-----	364-367
Inspector—	
farm produce, description, and nature and method of work-----	324-328
Federal, for farm produce, need and value of certificate-----	320-321
Inspectors, Federal, for tuberculosis in live stock, list and location-----	286-287
Internal revenue—	
receipts from tobacco-----	172-173
taxes on tobacco products and manufacturing-----	171-172, 173
Interstate roads, increase-----	54
Iowa, cattle, Federal inspection for tuberculosis, number, and address of inspector-----	286
Irons, electric, types and value in home-----	237, 238
Italy—	
farm animals, numbers and kinds, 1881-1914-----	645
live stock—	
prewar and postwar estimates and per cent change-----	423-424
situation, effect of war, and outlook-----	414-416
Ivory, vegetable, import statistics-----	685
Japan, farm animals, numbers and kinds, 1910-1916-----	645-646
Jobbing, prices and lots, meaning of term-----	98-102
Jute, import statistics-----	684, 703, 719
JUVE, OSCAR A., article on "The horsepower problem on the farm"-----	485-494
Kansas—	
cattle, Federal inspection for tuberculosis, number, and address of inspector-----	286
City market station, lines of work-----	96, 107
Kentucky—	
cattle, Federal inspection for tuberculosis, number, and address of inspector-----	286
tobacco production rank, 1869-1918-----	153
KIERNAN, J. A., and L. B. ERNEST, article on "The toll of tuberculosis in live stock"-----	277-288
KNAPP, BRADFORD, article on "Marketing and purchasing demonstrations in the South"-----	205-222
KRAMER, H. E., and G. B. FISKE, article on "Why produce inspection pays"-----	319-334
Labeling, seed, agreement of seedsmen-----	344-345
Labels, seed, information important to farmer-----	344
Labor—	
employed in tobacco manufacturing-----	175
farm—	
hiring methods-----	740
income, 1910-1918-----	740
wages for men on farms, by classes and States, 1910-1919-----	738-739
utilization in wheat growing and harvesting-----	133, 138, 143-146, 148-150
Labor-saving devices, electric light and power in the farm home-----	223-238
Laguna Project road, California, value to residents, note-----	185

	Page.
Lambs—	
farm prices 1910-1919	670
improvement by use of purebred sires	352
Land—	
agricultural, by countries	748-749
economics, project of Farm Management Office	37, 38
farm, problems, increased area, settlement, and tenancy	25-32
high prices obstacle to farm ownership	32
settlement, importance of advice to intending settlers	30
utilization, study, importance	29, 36, 37
Lands, plow, value, by States, 1917-1920	741
Language, study in country schools, requirements	293-294
Lard—	
compounds, exports statistics	691, 701
exports statistics	692, 701, 711
Law—	
bollworm control, Texas	360-362, 363
cotton zone, obstacles, tests and enforcement	363
Yearbook, authorization for printing and binding	2
Laws—	
State, personal credit unions, recommendation	57
tobacco duty, dates	169
Legislation, Federal, recommendations of Secretary	57-58
Legumes, bacteria, nitrogen-bearing	115-116
Lemons—	
Eureka and Lisbon varieties, fruit variations	255-258
imports, statistics	686, 704
shipments from California, 1918-19, and value	249
Lettuce, acreage and production, 1917, 1918	621
Licorice root, imports statistics	687, 699, 703
Light, electric, in the farm home (and electric power), article by A. M. Daniels	223-238
Lighting, electric, for farm home, considerations, wiring, etc	228-234
Lights, electric, location in farm home	230-232
Lime—	
agricultural—	
composition, grinding or burning	338
value, and use increase	335-336
burning or grinding, methods, value comparisons, etc	339-340
crushers and pulverizers, for farm use, capacity, cost, etc	339-340
home production by farmers, article by C. C. Fletcher	335-341
production, use, and value, resolutions of experiment station workers	340-341
purchasing vs. home production, comparisons, studies, and cost	336-340
Limekiln, home use, description, and comparison with lime crusher	339
Limestone, grinding, use of private or community power, suggestions	337
Lint, cotton, production statistics, 1910-1919	591
Liquors, alcoholic—	
exports statistics	695
imports statistics	687, 699
Lister, use in wheat growing	132
Live stock—	
Argentina, prewar and postwar estimates and per cent change	423
associations, list, with officials	502-508
Australia, prewar and postwar estimates and per cent change	423-424
Canada, prewar and postwar estimates and per cent change	423-424
conditions in Europe, article by Turner Wright and George A. Bell	407-424
conference at St. Paul, July, 1919	393-394
decline in Europe on account of war	9
drought relief—	
committee, appointment and personnel	391
work in 1919, article by George M. Rommel	391-405
estimates for 15 countries, prewar and postwar	423-424
exhibitions in Uruguay, practices and prices	375
foreign markets, South American conditions	369-380
grading up, principles	348

	Page.
Live stock—Continued.	
improvement—	
by use of purebred sires, examples	351-352
financial benefits	352-353
heredity principles, article by D. S. Burch	347-354
industry in European countries, effect of war, outlook, etc.	407-424
inspectors for tuberculosis, list and location	286-287
losses from tuberculosis, preventive measures	282-284
marketings, 1900-1919	679
markets, Federal supervision, article by Louis D. Hall	239-248
movements from northwest drought area	399-403
New Zealand, prewar and postwar estimates and per cent change	423-424
numbers and kinds, by countries	644-648
offices in drought emergency, various cities	394, 396
prewar and postwar estimates and per cent change	423-424
products, selling time, by months and by States	732
purebred—	
revival of interest in European countries	408, 411, 417-418, 420-421
selling to South America, article by David Harrell and H. P. Morgan	369-380
reporting service, enlargement, importance	41, 42-43
sale lists, assembling and distributing	395
sales at Palermo, Argentina, Exposition, classes and prices	377-378
selling time, by months and by States	732
shipments, emergency rates for drought sufferers	396, 403
show, Palermo, Argentina, importance, etc	373, 379
standards, development by Markets Bureau	247
statistics	644-681, 682, 700, 710, 716
statistics, numbers and exports	14, 644-681
toll of tuberculosis, article by J. A. Kiernan and L. B. Ernest	277-288
trade—	
development with South America, advantages and conditions	369-380
through market centers	239-240
value on farms by States, 1914-1918	678
values, 1910-1919	17
<i>See also</i> Asses; Cattle; Calves; Goats; Hogs; Horses; Lambs; Mules; Pigs; Sheep.	
Loading, car-lot produce, method and suggestions	322, 323, 324, 325, 326
Louisiana—	
cane-sugar production, 1911-1919	628
cattle, Federal inspection for tuberculosis, number, and address of inspector	286
molasses production, 1911-1918	628
Lumber—	
exports statistics	693, 700, 705, 715
imports statistics	686, 700, 706, 721
Lung plague, bovine, eradication	7, 76
Luxemburg, farm animals, numbers and kinds, 1917, 1918	646
Lymphangitis, symptoms and occurrence	72-73
Lynx—	
Canada, trapping directions	464-465
skins, casing directions	465
Machinery—	
farm, purchasing, advantages of cooperative associations	382, 384
trenching, description, operation, and use	79-83
Maine, cattle, Federal inspection for tuberculosis, number, and address of inspector	286
Mal de Caderas, symptoms, occurrence and fatality	72-73
Manila hemp, imports statistics	684, 703, 719
Maple products—	
production, by States, 1909, 1917-1919	635-636
yield per tree, by States	635-636
Maples, sugar, trees tapped and yield of sugar and sirup per tree, by States	635-636
Market—	
centers, live-stock trade, development and location	240, 243
news, scope and circulation	94-95, 97, 100, 111-112



	Page.
Market—Continued.	
station, man for work, character.....	95, 114
stations—	
object and use, article by G. B. Fiske.....	94-114
sources of information for producers and dealers.....	113-114
stocks and surplus products, estimates.....	40, 44
Marketing—	
cooperative, conditions requiring demonstration work.....	208-209
demonstrations—	
and purchasing, in the South, article by Bradford Knapp.....	205-222
relation of county agent, discussion.....	206-208
eggs, time and methods.....	316-317
farm products, problems.....	43-45
Markets—	
Bureau—	
activities.....	56
branch offices in various cities, lines of work.....	95-97
cooperation in live-stock drought relief.....	391-392
live-stock staff for market inspection, work and service.....	243-247
work in Federal supervision of live-stock markets.....	242-248
information, sources for producers and dealers.....	113-114
inspection, location, by States.....	333-334
live-stock—	
Federal supervision, article by Louis D. Hall.....	239-248
horses and mules received 1900-1919.....	656
quotations, explanation and use.....	98-102
reports—	
directions for use.....	104-107
preserving and filing.....	112-113
terms, abbreviations, and phrases, meaning.....	98, 102-104
Marl, occurrence, grades, and utilization for fertilizer.....	336-337
Maryland, cattle, Federal inspection for tuberculosis, number, and address of inspector.....	286
Massachusetts, cattle, Federal inspection for tuberculosis, number, and address of inspector.....	286
Meat—	
animals, prices, index numbers, 1910-1919.....	742
Commission, appointment and work.....	241-248
forecasts for 1919.....	11
inspection, Federal, establishments, condemnations of animals, etc.....	679-681
international trade by countries, 1911-1918.....	649-652
packers, Chicago, control of trade, discussion.....	340-341
production, imports, exports, and consumption, 1910-1918.....	742-744
statistics, exports and imports, 1910-1918.....	742-744
trade, international, live stock of 15 countries concerned.....	423
Meats—	
consumption, by sections, exports and imports, 1904-1919.....	744
cured and frozen—	
demand in Belgium.....	412
demand in France.....	410
exports statistics.....	691, 692, 700, 701, 710, 711
imports statistics.....	683
statistics—	
exports, imports, etc., 1910-1918.....	742, 744
production and exports, 1910-1919.....	12, 14, 16
<i>See also Beef; Pork.</i>	
MEHL, J. M., article on "The farmers' purchase power, how organized".....	381-390
Mexico—	
border ports, pink bollworm quarantine measure.....	359
farm animals, numbers and kinds, 1902.....	646
pink bollworm discovery.....	357-359
Mice, trapping methods.....	454
Michigan—	
cattle, Federal inspection for tuberculosis, number, and address of inspector.....	286
live-stock movement from drought area in Northwest.....	400, 401

	Page.
Milk—	
condensed—	
demand in Belgium .....	412
demand in Italy .....	416
use in France, note .....	410
exports statistics .....	691
forecasts for 1919 .....	11
Milking, electrical, note .....	225
Mink skins, casing directions .....	461, 477
Minks, trapping directions .....	461
Minneapolis, market station, lines of work .....	96
Minnesota—	
cattle, Federal inspection for tuberculosis, number, and address of inspector .....	286
live-stock movement from drought area in Northwest .....	393, 400, 401
Mississippi—	
cattle, Federal inspection for tuberculosis, number, and address of inspector .....	286
marketing, cooperative, work and results .....	210-214
Missouri, cattle, Federal inspection for tuberculosis, number, and address of inspector .....	286
Mohair, marketing, cooperative work .....	220
MOHLER, JOHN R., article on "Progress in eradicating contagious animal diseases" .....	69-78
Molasses—	
exports statistics .....	696, 699
imports statistics .....	689, 699, 703
production in Louisiana, 1911-1918 .....	628
Mole—	
skins, drying .....	474, 477
traps, description and use .....	471-474
Moles, trapping directions .....	472-474
Montana—	
Bitterroot-Bighole road, value to settlers, historical notes, etc. ...	182-183, 185-186
cattle, Federal inspection for tuberculosis, number, and address of inspector .....	286
drought conditions, 1919 .....	396-399
sheep movement to Minnesota to avoid drought .....	393
MORGAN, H. P., and DAVID HARRELL, article on "Selling purebred stock to South America" .....	369-380
Moths, injuries to furs, and control .....	481
Motor—	
electrical portable utility, description and uses in the home .....	225-227
trucks, hauls, farm to shipping points, 1906-1918 .....	746
vehicles, increase in traffic and road needs .....	53-54
Mules—	
exports, 1893-1919 .....	657
exports statistics .....	691
number—	
and value on farms, 1867-1920 .....	653
and value on farms, by States, 1910, 1919 .....	654
received at live-stock markets, 1900-1919 (with horses) .....	656
numbers, by countries .....	644-648
prices at St. Louis, 1900-1919 .....	655
statistics .....	653-657, 679
Muskrat, skins, casing directions .....	475, 479
Musk rats—	
distribution and habits .....	452, 474-475
trapping directions .....	475
National Forests. See Forests, National.	
Naval stores—	
exports statistics .....	641, 642, 693, 699, 705, 715
imports statistics .....	641, 642, 685, 699

	Page.
Nebraska, cattle, Federal inspection for tuberculosis, number, and address of inspector-----	286
Netherlands—	
farm animals, numbers and kinds, 1890-1919-----	646
live stock, prewar and postwar estimates and per cent change-----	423-424
live-stock industry, conditions-----	416-418
Nevada, cattle, Federal inspection for tuberculosis, number, and address of inspector-----	286
New England States, crop yields, gains per cent since 1876-----	23
New Hampshire, cattle, Federal inspection for tuberculosis, number, and address of inspector-----	286
New Jersey, cattle, Federal inspection for tuberculosis, number, and address of inspector-----	286
New Mexico, live-stock movement from drought area in Northwest-----	400, 401-403
New York—	
cattle, Federal inspection for tuberculosis, number, and address of inspector-----	286
community drainage work-----	79-88
crop yields, increase since 1876-----	22
market station, lines of work-----	96, 101, 111
New Zealand—	
farm animals, numbers and kinds, 1890-1918-----	646
live stock, prewar and postwar estimates and per cent change-----	423-424
News, market, scope and circulation-----	94-95, 97, 100, 111-112
Nez Perce Indians, retreat over route of Bitterroot-Bighole road, historical notes-----	185-186
Niagara Falls, nitrate plant, production of cyanamid-----	119
Nitrate—	
deposits, source of nitrogen fertilizer-----	116
plants, Alabama, building and possible output-----	120
Nitride process, nitrogen fixation-----	118
Nitrogen—	
atmospheric—	
fixation, methods-----	117-120
for fertilizers, article by R. O. E. Davis-----	115-121
consumption and demand-----	121
shortage in United States-----	116
supplies, sources in nature-----	115-117
Noncotton zones, establishment by Texas law, contest and results-----	360-362, 363, 368
North Carolina—	
cattle, Federal inspection for tuberculosis, number, and address of inspector-----	286
tobacco production, rank, 1899-1918-----	153-154
North Dakota, cattle, Federal inspection for tuberculosis, number, and address of inspector-----	286
Northern States, tobacco production, rank, 1839-1918-----	153
Norway—	
farm animals, numbers and kinds, 1890-1918-----	646
live stock, prewar and postwar estimates, and per cent change-----	423
Nursery stock, imports statistics-----	687, 699
Nuts—	
exports statistics-----	695, 699
imports statistics-----	687, 699, 720
Oats—	
acreage and production, by countries, 1909-1919-----	531-532
consumption, total and per capita, by countries-----	565, 566
exports, 1866-1919-----	533
exports statistics-----	694
imports, 1866-1919-----	533
market, prices by months, 1913-1919-----	538
marketings, by months, 1914-1919-----	537
prices, by States and by months-----	536-538
production, by countries, 1900-1918-----	565, 566
statistics, acreage, yield, prices, etc-----	531-539

	Page.
Oats—Continued.	
supplies, old stock, production and quality	535
trade, international	539
yield per acre, by States, 1910-1919	536
yields, changes since 1876	20, 22, 23
Ohio—	
cattle, Federal inspection for tuberculosis, number, and address of inspector	286
tobacco production rank, 1914-1918	154
Oil cake—	
exports and statistics	696, 699, 701, 714
meal, trade, international	641
trade, international	641
Oils, vegetable—	
exports statistics	696, 699, 714
imports statistics	688, 699, 720
Oklahoma, cattle, Federal inspection for tuberculosis, number, and address of inspector	286
Olive oil, imports statistics	688, 703-704, 720
Olives, imports statistics	686
Onions—	
acreage, yield, and production, 1910-1919	621, 622
exports statistics	697
growers, help by market station	113
imports statistics	690, 704
prices—	
by months, 1910-1919	622
in market season, 1918-1919	110
Ophthalmic tuberculin test, reaction symptoms, etc	284
Opium, imports statistics	688, 699, 703, 720
Opossum, skins, casing directions	470
Opossums, trapping directions	470
Orange, Washington navel, fruit variations	254-255, 260-261
Oranges—	
exports statistics	712
imports statistics	686, 704
prices, farm value, etc	608
production and value, 1915-1919	608
shipments from California, 1918-1919, and value	249
statistics, production, prices, and value	608
varieties grown in California, 1918-1919	249
Orchard surveys, value in fruit-variation studies	256-257
Oregon, cattle, Federal inspection for tuberculosis, number, and address of inspector	287
Otter skins, casing directions	463
Otters, trapping directions	462-463
OUSLEY, CLARENCE, Assistant Secretary, instructions on live-stock drought relief	391-392
Oversupply, perishables, relation to marketing	108, 111
Owls, trapping	457
Pacific area, wheat-growing conditions and practices	126, 134, 141, 144, 145, 148, 149
Packing-house products—	
exports statistics	691, 699, 701, 710-711
imports statistics	683, 699, 717
Paint, damp-proofing, nature and application to walls	433-437
Paraguay—	
farm animals, numbers and kinds, 1877-1915	646
live-stock industry, conditions	374
Peaches—	
commercial crop, production, estimates, 1917-1919	606
growers, benefit of market news reports	112
marketing, cooperative management and profits	218
prices on farm	606
production, estimates 1899-1919	605
statistics, production and prices, by States	605-606

	Page.
Peanuts—	
acreage, yield, production, prices, etc.....	619-620
exports statistics .....	620-695
marketing, cooperative, profits, etc., instance.....	215
prices, 1910-1919 .....	619
production, various countries, 1911-1918.....	620
statistics, acreage, production, value, etc., by States, 1916-1919.....	619-620
world crop, statistics.....	619-620
Pears—	
prices on farm.....	608
production, 1918, 1919.....	607, 608
statistics, production, and prices.....	607-608
Peas—	
acreage and production, 1909-1918.....	617, 621
world crop, statistics, 1909-1918.....	617
Pecos Valley, Texas, cotton-growing restrictions.....	364-367
Peltries. <i>See</i> Furs; Skins.	
Pennsylvania—	
cattle, Federal inspection for tuberculosis, number, and address of inspector .....	287
tobacco production, rank, 1914-1918.....	154
Perishables, market developments, natural course.....	108
Philadelphia, market station lines of work.....	96, 107
Philippine Islands—	
farm animals, numbers and kinds, 1902-1919.....	646
tobacco crop, percentage of world crop.....	156
tobacco shipments to and from United States.....	162-163
Physical training, study in country schools, requirements.....	299
Picking, citrus fruit, record-kept trees, methods.....	262-264
Pigs, improvement by use of purebred sires.....	352
Pink bollworm. <i>See</i> Bollworm, pink.	
Plant Industry Bureau, citrus bud variations, investigations.....	251-261
Plaster, use for waterproofing cellar.....	446
Pleuropneumonia, cattle, extent and eradication.....	70, 76
Plow—	
lands, value, by States, 1917-1920.....	741
team, number of horses used in parts of United States.....	492
Plowing—	
tractor, relation to season of year.....	488
wheat seed bed.....	128, 130, 131, 133
Plug tobacco, production, pounds consumed.....	174
Population, rural and agricultural, by countries.....	747-748
Porcupines, trapping methods.....	454-455
Pork—	
American, disfavor in European countries.....	410, 420
exports statistics .....	692, 701, 711
importation by United Kingdom, need.....	420
Portland, market station, lines of work.....	96
Porto Rico—	
shipments—	
from the United States, 1917-1919.....	709
to the United States, 1917-1919.....	709
tobacco—	
production, percentage of world crop.....	156
shipments to and from United States.....	162-163
Portugal, farm animals, numbers and kinds, 1870, 1906.....	646
Post Office Act, provision for forest roads.....	180
Potash, value in crop yields, estimates by Germany.....	68
Potatoes—	
acreage—	
and production 1917, 1918.....	621
production, values, exports, etc.....	568-576
exports—	
and imports, 1911-1913, 1917, 1918.....	576
statistics.....	697
imports statistics.....	690, 703
growers, help by market station.....	113
market reports, directions for use.....	104-107

## Potatoes—Continued.

	Page.
prices—	
in market season, 1918-1919	110
on farm, by months, 1910-1919	574
wholesale, 1913-1919	575
statistics, acreage, yield, values, exports, imports, prices, etc.	568-576
stocks, January 1, 1916-1920	573-574
sweet. <i>See</i> Sweet potatoes.	
world crop, statistics	568-576
yield per acre, prices, etc., by States	572, 574
yields changes since 1876	21, 22, 23
<b>Poultry—</b>	
breeds recommended for farm flocks	309-310
common sense in keeping, article by Rob R. Slocum	307-317
good stock, importance in successful farm flocks	308-310
improvement by use of pure-bred sires	352
keeping, studies	307-317
production in 1919, forecast and statistics	11, 14, 28
protection from wild animals	452, 484
<b>Power—</b>	
electric, in the farm home (and electric light), article by A. M. Daniels	223-238
horse, problem on the farm, article by Oscar A. Juve	485-494
private or community, utilization in grinding limestone	337
problem on farm, factors	485
relation to employment of human labor	488-489
<b>Prairie—</b>	
dogs, trapping methods	454
hay, price, 1915-1919	584
Prairie-dog trap, use for catching wolves, directions	468-470
<b>Prices—</b>	
beets, 1913-1919	626
butter, at principal markets, by months, 1913-1919	661, 664
cattle, by months, 1913-1919	660-661
corn, 1866-1919	510-511, 514-516
eggs, 1913-1919	664-665
farm crops, index numbers, monthly and average, 1910-1919	736
farmers', for principal articles bought, 1909-1919	736-738
hogs, on farm and at market	675-677
horses and mules, at principal markets	655-656
live stock—	
at Palermo Exposition, Argentina, 1919	377-378
by ages and classes, 1914-1920	679
maple sugar, by months, 1913-1919	636
market, movements, causes	109-110
oats, by States and by months	536-538
quotations in market news reports, use	98, 102
rice, by States and by months, 1910-1919	562-563
rye, by States and by months, 1910-1919	552-553
sheep, 1910-1919	669-671
tobacco, since 1863	154-155
wheat, by States, 1866-1919	520-522, 525-526
wool, by months, 1913-1919	672-674
Printing, Yearbook, law authorization	2
<b>Produce—</b>	
inspection—	
comparison with trade insurance	321
saving to War Department	321
Production cost, studies, project of Farm Management Office, work	35-36, 38
Prunes, exports statistics	701, 712
<b>Pulp, wood—</b>	
imports statistics	686, 700, 706, 721
international trade	643
<b>Purchasing—</b>	
association, limit of activities	384-385

## Purchasing—Continued.

	Page.
cooperative—	
conditions requiring demonstration work	208-209
possibilities and limitations	382-385
demonstrations and marketing in the South, article by Bradford Knapp	205-222
organizations among farmers, article by J. M. Mehl	381-390
Purebred stock, definition	349
Quarantine, pink bollworm	356-357
Quotations, market, explanation and use	98-102
Rabbits, trapping, methods	455
Raccoon, skins, drying directions	470
Raccoons, trapping directions	470
Railroad Administration, cooperation in live-stock drought relief	392, 396, 404
Railways, freight tonnage, United States	745
Raisins, imports statistics	686, 704
Rats, trapping, methods	453-454
Recommendations, Secretary's	30, 39, 43, 45, 55, 57-59
Rhode Island, cattle, Federal inspection for tuberculosis, number, and address of inspector	287
Rice—	
acreage and production, by countries, 1909-1918	561-562
consumption, total and per capita, by countries	565-566
exports statistics	696, 699, 702
imports statistics	688, 699, 703-704
prices, by States and by months, 1910-1919	562-563
production, by countries, 1909-1913	565
statistics, acreage, yield, prices, etc.	561-564
trade, international, 1909-1913, 1917, 1918	564
yield per acre, by States	562
Rinderpest, nature, occurrence, and fatality	76-77
Road—	
Federal-aid Act, passage, amendment, and results	46-50, 55, 56
Fourth of July Canyon, route, note	185
projects, approval, mileage, and cost	49
Roads—	
Bureau—	
duties and authority, remarks by Secretary	52
new chief, remarks by Secretary	48
substitution of Highway Commission, discussion	50-54
damage by heavy traffic during war	46
forest, appropriation and progress of work	46, 49
importance to farmers, administration, etc., discussion	45-55
National Forests—	
article by John L. Cobbs, jr.	177-188
funds available for building	180
State, Federal-aid funds participation, etc.	46-50, 52
Rocky Mountain area, wheat-growing conditions	126
Rodent pests, trapping for profit	451-452
Rodents, trapping on farm, directions	452-456
Roller, use in wheat growing	128, 129, 133, 134, 135
ROMMEL, GEORGE M., article on "Live-stock drought relief work in 1919"	391-405
Roof-water disposal, practices and suggestions	430-432
Rosin—	
exports statistics	693, 699, 705, 715
trade, international	641, 685, 699
Rotation, crops in wheat growing	126, 128, 130, 138, 140
Rubber, india, trade, international	642
Rumania, farm animals, numbers and kinds, 1890-1916	646
Rural—	
population, statistics	747-748
post roads, appropriations, definition, and State participation	46, 48
survey, need of	58
Russia—	
farm animals, numbers and kinds, 1913-1914	646
tobacco production, percentage of world's crop	156

	Page.
Rye—	
acreaage and production—	
by countries, 1909-1919	547-548
by States	550
consumption, total and per capita, by countries	565-567
exports, 1867-1919	549
exports statistics	694
market, prices by months, 1913-1919	553
price per bushel, by States and by months, 1910-1919	552-553
production, by countries, 1909-1918	565, 567
statistics, acreage, yield, prices, etc.	547-554
trade, international, 1911-1913, 1917, 1918	554
Sago, imports statistics	688, 699
San Francisco, market station, lines of work	96
Sanitation, hog-cholera control, suggestions	200-202
Scabies—	
cattle, eradication work	71, 77-78
sheep, eradication work	72, 77-78
Scents, uses in trapping animals, preparation	467, 468
School—	
country, reorganization, article by Alvin Dille	289-306
public, mission and requirements	291-293
rural, building, equipment requirements	299-301
Schools—	
country—	
course of study, requirements	293-299
deficiencies and needs	301-303
improvement of physical equipment needs, discussion	299-301
reorganization in rural districts, advantages	303-306
standards of reorganization	291-293
Scrap tobacco, customs duties and internal-revenue tax	170, 172
Scrub stock, elimination by use of purebred sires	349-350
Scrubs, comparison with grade animals in growth and quality	351-352
Secretary. <i>See</i> Agriculture.	
Seed—	
clover, acreage, production, price, and value	586-588
red-clover, from southern Europe, unsatisfactory results	345
testing for sale to farmers	343-344
timothy, prices, farm and wholesale	586-588
Seed-bed—	
wheat—	
preparation after broadcast crops	126-137
preparation after intertilled crops	138-141
Seeds—	
citrus—	
reliable, securing cooperation	271
selected, uses, sales, etc.	270-271
exports statistics	696, 699
imported, labeling as to origin	344
imports statistics	689, 699, 720
labeling—	
agreement of seedsmen	344-345
failure in trade	345
trade—	
relation to agriculture	343-346
representatives meeting and agreement, 1917	344
vegetable, acreage, yield, and production, 1917-1919	734
vitality and germination test, label notice	344
Seedsmen, duty to farmers, article by Edgar Brown	343-346
Seneca Power Ditching Co., purpose and work	80-83
Separator, electric, description	236
Serbia, farm animals, numbers and kinds, 1905, 1910	646
Serum, anti-hog-cholera, production and administration, cost, 1918	202
Settlers, need of special advice and assistance	30
Sewing, electric motor, description	227
SHAMEL, A. D., article on "Cooperative improvement of citrus varieties"	249-275



	Page.
Sheep—	
Argentina, prewar and postwar estimates and per cent change	423
Australia, prewar and postwar estimates and per cent change	423
Canada, prewar and postwar estimates and per cent change	423
European countries, prewar and postwar estimates and per cent change	423-424
France, effect of war on industry	409
imports—	
and exports, 1893-1919	670
statistics	682
limited prewar supply and cause	341
marketings, 1900-1919	679
New Zealand, prewar and postwar estimates and per cent change	423
number and value, 1867-1920	668
numbers, by countries	644-648
prewar and postwar estimates and per cent change in United States	423
prices, 1910-1919	669-671
scabies, eradication work	72, 77-78
statistics	668-671, 679
Sheepskins, imports statistics	683, 718
Shellac, imports statistics	685, 706
Shocks, thrashing of wheat	148
Shopwork, farm, study in country schools, requirements	298-299
Silk—	
imports statistics	682, 699, 702, 703, 717
production, by countries, 1909-1918	643
Sires, purebred, effect on offspring, and saving of money	349-353
Sirup—	
maple, production, by States, 1909, 1917-1919	635-636
production, by States	628, 635-636, 637
sorghum, production, by States	637
Sisal grass, imports statistics	684, 703, 719
Skins—	
dressing—	
at home	480
for home use, directions	479-481
exports statistics	691
fur, drying directions	460, 461, 462, 463, 465, 467, 470, 474, 475, 476, 477-481
imports statistics	683, 704, 717-718
mink, casing directions	461, 477
of fur animals, preparation, drying and casing	477-481
seasons when prime	482
skunk, casing directions	460
wildcat, drying directions	464
wolf, casing directions	470
<i>See also Hides.</i>	
Skunks—	
food habits beneficial to farmer	451, 459
trapping directions	459-461
SLOCUM, ROB R., article on "Common sense in poultry keeping"	307-317
SMITH, C. B., member of committee on live-stock drought relief	391
Smoking tobacco—	
pounds consumed in manufacture	174
tax by internal revenue	171-172
Snuff—	
import duty and internal-revenue tax	169, 171
production, increase	174-175
Sodium cyanide, source of ammonia	119
Sorghum, production for sirup, acreage, amount and value	637
Sorghums, grain—	
acreage, production, prices, and value, 1915-1919	618-619
prices, farms, 1916-1919	618, 619
South—	
cooperative organizations for marketing and purchasing, work of county agents	208-222
marketing and purchasing demonstrations, article by Bradford Knapp	205-222

	Page.
South America—	
live-stock market for United States	369-380
purchase of purebred stock from United States, value of trade, etc.	369-371
South Atlantic States, tobacco growing, percentage, 1839-1918	153
South Carolina—	
cattle, Federal inspection for tuberculosis, number, and address of inspector	287
tobacco production, rank, 1914-1918	154
South Central States, tobacco growing, percentage, 1839-1918	153
South Dakota, cattle, Federal inspection for tuberculosis, number, and address of inspector	287
Soy beans—	
acreage, production, prices, and value, by States, 1919, and totals, 1917-1919	616
prices on farm, 1913-1919	616
seed, labeling with origin	344
Soya-bean oil, imports statistics	688, 720
SPAFFORD, R. R., and J. H. ARNOLD, article on "Farm practices in growing wheat"	123-150
Spain, farm animals, numbers and kinds, 1891-1916	647
Sparrows, English, trapping directions	457, 461
Specialists, marketing and purchasing demonstrations, purpose, discussion	206-208
Spices—	
exports statistics	696, 699
imports statistics	689, 699
Spokane, market station, lines of work	96
Spraying, material for, purchasing, advantages of cooperative associations	382, 384
Squirrels, ground, trapping methods	454
St. Louis, market station, lines of work	96, 107
St. Paul, live-stock emergency office establishment	394
Stacks, thrashing of wheat	147-148
Standardization, farm products	44
Standards, live stock, development by Markets Bureau	247
Starch, exports statistics	696, 699
States Relations Service, cooperation in live-stock drought relief	391-392
Statistics—	
collection by Crop Estimates Bureau	40
crops—	
and live stock	12-16, 509-681
grain	509-567
other than grain	568-643
grain crops, acreage, production, etc.	509-567
live-stock, and live-stock products	644-681
Steel traps, use in trapping large animals	458-470, 475, 476
Steers, improvement by use of purebred sires	351-352
Stock. <i>See</i> Live stock.	
Stocks, tobacco of various types, October 1, 1912-1919	164
Stockyards—	
change in market hours	245
Chicago, volume of business	239, 240-241
complaints referred to Washington office, nature	246
improvement under Federal inspection	246
Stoves, electric portable, types and uses	235-238
Strawberries, acreage and production, 1917, 1918	621
"Stubbling in," wheat	135-137, 138, 148
Sugar—	
beet—	
production, by countries, 1909-1919	631-633
production, by States, 1913-1919	627-628
cane—	
production, by countries, 1910-1919	634-635
production, by States and Territories, 1856-1919	625
exports statistics	696, 699, 702
imports statistics	689, 699, 703-704, 720

## Sugar—Continued.

	Page.
maple—	
prices, by months, 1913–1919	636
production, by States, 1909, 1917–1919	635–636
prices by months, New York market, 1913–1919	629–630
production—	
by countries, 1909–1919	631–634
by States and Territories	625–629
statistics, 1856–1919	625–636
supply, total and per capita, 1901–1919	628
trade, international, 1909–1913, 1917, 1918	630
Summer fallow, alternation with wheat	130, 132, 134
Surra, horse disease, nature, occurrence and fatality	77
Surveys—	
forestry, need	34–35
orchard, value in fruit-variation studies	256–257
rural, need	58
Sweden—	
farm animals, numbers and kinds, 1890–1918	647
live stock, prewar and postwar estimates and per cent change	423–424
Sweet potatoes—	
acreage, production, value, etc	577–579
prices, farm and wholesale, 1910–1919	579
yield, price, and acre value, by States, 1910–1919	578
Swine—	
Argentina, prewar and postwar estimates and per cent change	423
Australia, prewar and postwar estimates and per cent change	423
Canada, prewar and postwar estimates and per cent change	423
European countries, prewar and postwar estimates and per cent change	423–424
New Zealand, prewar and postwar estimates and per cent change	423
numbers, by countries	644–648
prewar and postwar estimates and per cent change in United States	423
Uruguay industry, conditions	375–376
<i>See also Hogs.</i>	
Switches, electric, location and type for farm home	230–233
Switzerland—	
cheese industry, effect of war	413
farm animals, numbers and kinds, 1901–1918	647
live stock—	
prewar and postwar estimates, and per cent change	423–424
situation and outlook	413–414
Tallow, imports statistics	684
Tanning—	
liquor for fur skins	479
materials, imports statistics	685, 699
Taxes, internal revenue, tobacco products and manufacturing	171–172, 173
TAYLOR—	
ALONZO ENGLEBERT—	
article on—	
“Influence of depreciation of exchange on agricultural production”	189–196
“Prewar crop estimates in Germany”	61–68
Dr. H. C., appointment as Chief of Office of Farm Management	37–38
Tea—	
imports statistics	689, 699, 703, 721
prices on New York market, 1913–1919, by months	638
trade, international	637
Tenancy, farm, leasing methods, need of improvement	30–32
Tennessee, cattle, Federal inspection for tuberculosis, number, and address of inspector	287
Test, tuberculin, importance in control of tuberculosis in live stock	282–288
Testing—	
seed, for sale to farmers	343–244
tuberculin, methods	284

	Page.
Texas—	
cattle—	
Federal inspection for tuberculosis, number, and address of inspector .....	287
movement to Southeast in 1917, 1918, results .....	401
drought conditions, 1917-18, and revival .....	397, 401-402
live-stock movement from drought area in Northwest .....	400, 401-403
marketing, cooperative work of county agents, and results .....	217-220
Pecos Valley, cotton-growing restrictions .....	364-367
pink bollworm—	
Act .....	360-362
control work, methods .....	362, 367-368
introduction .....	359, 360
purchasing, cooperative work of county agents, and results .....	220-221
Trinity Bay section cotton-growing restrictions .....	363-364
western, pink bollworm infestation discovery, 1918 .....	364-365
wheat growing in cotton region, note .....	124
Thrashing, wheat, methods .....	164-148
Ticks, cattle, suppression, chart .....	74
Tile, drainage—	
community construction, article by John R. Haswell .....	79-93
<i>See also</i> Drainage.	
Timber, exports statistics .....	694, 705, 715
Timothy seed, prices, farm and wholesale .....	586-588
Tobacco—	
acreage, 1849-1919 .....	596, 597
acreage in 1863-1918 .....	157
as world crop .....	156
colonial history .....	151-154
consumption—	
analysis of facts .....	165-168
percentage of crop .....	168
crop—	
census reports, 1839-1909 .....	152
increase in value, since 1618 .....	155
domestic, exports .....	158-160
exports—	
and imports .....	601
countries to which consigned, and world's trade .....	158-160
statistics .....	697, 699, 701, 714
growing, changes in groups of States .....	153-154
import duties, history .....	169-171, 172, 173
imports—	
and exports .....	601
statistics .....	689, 699, 721
1789-1918, world's trade, etc .....	160-162
industry, origin and growth .....	151-158
leaf, supply and distribution in United States, 1918 .....	164
manufactured—	
exports .....	159
import duties and internal revenue rates .....	170, 171
manufacturing—	
and dealing, internal-revenue taxes .....	171, 172
industry, magnitude, capital, labor, etc .....	173-175
pounds used annually, 1790, 1839-1918 .....	166-167
prices—	
1913-1919 .....	600
since 1863 .....	154-155
production—	
per capita .....	154
values, exports, imports, etc .....	590-601
statistics, acreage, production, yield, prices, value, etc .....	596-601
stocks, annual carryover .....	163-164
three centuries of, article by George K. Holmes .....	151-175
trade with Philippine Islands and Porto Rico .....	162-163

	Page.
Tobacco—Continued.	
value of crop, per acre-----	155-156
world—	
crops, statistics-----	596-601
imports of, percentages-----	161-162
yield per acre—	
and relation to population-----	157-158
1910-1919, by States-----	598
Tomatoes—	
acreaage—	
and production, 1917, 1918-----	621
yield and production by States, 1917-1919-----	623-624
growers, help by market station-----	113
price per bushel, by months, 1912-1919-----	625
statistics, acreage, yield, prices, etc., 1917-1919-----	623-625
Tonnage, railway freight, 1915-1918-----	745
Tractor, adaptation for plowing to season of year-----	488
Tractors, farm, in United States, statistics-----	745-746
Trade, foreign—	
agricultural products, 1852-1919-----	698
forest products, 1852-1919-----	705-706
Trapping, farm, article by Ned Dearborn-----	451-484
Traps—	
setting for foxes, directions-----	465-467
types used for rats, mice, moles, etc-----	453, 455, 457, 471-474
use for catching larger animals, directions-----	458-476
Tree, records, object and keeping methods-----	261-265, 266-267
Trenching machinery, description and operation-----	79-83
Trinity Bay section, Tex., cotton-growing restrictions-----	363-364
Tree crops, acreage and production, 1917, 1918-----	621-625
Tuberculin test—	
importance in control of tuberculosis in live stock-----	282-288
methods-----	284
Tuberculosis—	
bovine, eradication in District of Columbia-----	73
eradication, cooperative work, chart-----	74, 78
Eradication Division, purpose and work-----	279-288
live stock—	
control, economic importance-----	280-281
control work-----	278-288
loss, article by J. A. Kiernan and L. B. Ernest-----	277-288
Turkey, farm animals, numbers and kinds, 1905-1913-----	647
Turkeys, prices, 1915-1920-----	668
Turnips, prices by months, 1912-1919-----	625
Turpentine—	
exports statistics-----	693, 699, 705, 715
trade, international-----	642, 685, 699
Twist tobacco, production increase-----	175
Union of South Africa, farm animals, numbers and kinds, 1904-1916-----	647
United Kingdom—	
crop yields, comparison with United States-----	24, 25
farm animals, numbers and kinds, 1910-1918-----	647
live stock, prewar and postwar, and per cent change-----	423-424
live-stock conditions, effect of war, etc-----	418-421
Uruguay—	
farm animals, numbers and kinds, 1860-1916-----	647
live-stock industry, conditions and outlook-----	374-376
Utah, cattle, Federal inspection for tuberculosis, number, and address of inspector-----	287
Vacuum cleaner, electric, types and value in home-----	329
Vanilla beans, imports statistics-----	690, 699
Vegetables—	
exports statistics-----	697, 699
imports statistics-----	690, 699
inspection by department agents-----	44

	Page.
Vegetables—Continued.	
seeds, acreage, yield and production, 1917-1919	734
statistics, production in 1910-1919	13
<i>See also</i> Asparagus; Beans; Beets; Cabbage; Cauliflower; Celery; Cucumbers; Lettuce; Peas; Potatoes; Sweet Potatoes; Tomatoes.	
Vermont, cattle, Federal inspection for tuberculosis, number, and address of inspector	287
Virginia—	
cattle, Federal inspection for tuberculosis, number, and address of inspector	287
tobacco production, rank, 1839-1918	153-154
Vocational Education Act, objects	57
Volunteer cotton, inspection work in pink bollworm control	363-364, 365
Wages—	
farm, by classes	738-739
tobacco manufacturing	175
Wagons, hauls, farm to shipping points, 1906-1918	746
WALL, JOHN C., defense of Texas pink bollworm law	361
Walnuts, imports statistics	688, 704, 720
Warehouse—	
Act, object and results	56
expenses, elimination by purchasing associations	382
Warren County Ditching Co., New York, purpose and work	83-85
WARREN, GEORGE M., article on "Securing a dry cellar"	425-449
Washing machine, description and value in the home	236, 238
Washington, cattle, Federal inspection for tuberculosis, number, and address of inspector	287
Water power, National Forests, permits and revenue, 1915-1919	750
Watermelons—	
acreage and production, 1917, 1918	621
marketing, cooperative management, and profits	217
Waterproofing—	
cellar, methods and directions	437-449
integral system, use in cellars	438-446
membrane system, use in cellars	447-549
Wax, vegetable, imports statistics	690-699
Weasel, skins, casing, directions	462
Weasels, trapping directions	461-462
Weeder, use in wheat growing	130, 131
Weeks forestry law, land acquisition under	34
West Virginia, cattle, Federal inspection for tuberculosis, number, and address of inspector	287
Wheat—	
abandoned acreage, 1902-1919	527
acreage—	
and estimated yield, 1919	10
production and farm value, by States	524-526
production and yield, by countries, 1909-1919	517-519
area in United States, map	124
areas, climate, and differing practices	126
consumption, total, and per capita, by countries	565, 567
drilling—	
and broadcasting	141-143
into stubble and standing corn	128, 135-137, 138-139, 148
exports, 1849-1919	520
exports statistics	694, 702, 713
France, Government price, subsidy, etc	190
Germany, cost of imports	191
growing, farm practices	123-150
harvesting, methods	143-146
imports statistics	686
market price per bushel by months, 1913-1919	528
marketing, by months, 1914-1919	527
price, relation of foreign exporters	191
prices, by States, 1866-1919	520-522, 525-526
production, by countries, 1909-1918	565, 567

	Page.
Wheat—Continued.	
seed-bed, preparation after other crops	126-141
spring, zones and conditions	124-126
statistics, acreage, yield, prices, etc	517-530
supplies, old stock, production and quality	525
thrashing, methods	146-148
trade, international	517
war-time prices, by countries, 1913-1918	734
winter, zones and conditions	124-126
yield and farm price, 1866-1919	520-523
yields, changes since 1876	19, 22, 23
WHITE, T. P., article on "Practical points in hog-cholera control"	197-204
Wildcats, trapping directions	463-464
WILLIAMSON, J. D., defense of Texas pink bollworm law	362
Wiring plant, electric, for farm home, requirements and suggestions	228-235
Wisconsin—	
cattle, Federal inspection for tuberculosis, number, and address of inspector	287
live-stock movement from drought area in Northwest	400, 401
tobacco production rank, 1914-1918	154
Wolves, trapping directions	468-470
Wood—	
exports statistics	693, 700, 705, 715
imports statistics	685, 700, 706, 721
pulp, trade, international, 1909-1918	643
Woodchucks, trapping methods	454
Woodlands, farm, importance and value	33
Wool—	
exports statistics	691, 699
imports statistics	682, 699, 702-703, 717
marketing, profits, etc	219-220
prices, by months, 1913-1919	672-674
production, 1909-1919	14
production and number and weight of fleeces, 1918, 1919, by States	672
statistics	672-675
trade, international, by countries, 1909-1912, 1917, 1918	675
Wrapper tobacco, import duty	169
WRIGHT, TURNER, and GEORGE A. BELL, article on "Live stock conditions in Europe"	407-424
Wyoming—	
cattle, Federal inspection for tuberculosis, number, and address of inspector	287
drought conditions, 1919	398
Yearbook, law authorizing printing, binding, and distribution	2
Yeast, exports statistics	697

STATE LIBRARY OF IOWA



3 1723 02109 2275