

HIGHWAY ENGINEERING

BY

CHAS. E. MORRISON, A.M., C.E.

Tutor in Civil Engineering, Columbia University

FIRST EDITION

FIRST THOUSAND

NEW YORK:

JOHN WILEY & SONS

LONDON: CHAPMAN & HALL, LIMITED

1908



COPYRIGHT, 1908,
By CHAS. E. MORRISON

PRESS OF THE PUBLISHERS PRINTING COMPANY, NEW YORK, U. S. A.

PREFACE

THE following pages were prepared for the second-year students of the department of civil engineering at Columbia University, with a view to furnishing a text in which the fundamentals of the subject should not be buried in a mass of detail, such as is frequently found to be the case in works of a similar character.

This book is, therefore, not a reference-work, but rather one in which it has been the endeavor to outline and emphasize those basic principles which are essential to good highways.

Acknowledgment is here made for the assistance that has been obtained from the many excellent works on the subject, and from the Government and State reports. In a number of cases these have been quoted from quite freely.

COLUMBIA UNIVERSITY, August, 1908.

CONTENTS

	PAGE
CHAPTER I	
ROAD RESISTANCES	1
CHAPTER II	
EARTH ROADS	24
CHAPTER III	
GRAVEL ROADS	64
CHAPTER IV	
BROKEN-STONE ROADS	70
CHAPTER V	
MISCELLANEOUS ROADS	143
CHAPTER VI	
STREET DESIGN	156
CHAPTER VII	
STONE PAVEMENTS	176
CHAPTER VIII	
BRICK PAVEMENTS	194
CHAPTER IX	
ASPHALT PAVEMENTS	222
CHAPTER X	
MODERN WOODEN PAVEMENTS	273

HIGHWAY ENGINEERING

CHAPTER I

ROAD RESISTANCES

SINCE in transportation of any kind, whether by means of cars as on railways, or wagons as on ordinary roads, the object is to haul a load as cheaply as possible—that is, aside from the questions of initial cost and maintenance and repair, to haul the greatest load with the least expenditure of energy—it will be quite proper in the subject of roads and pavements to consider first those factors tending to affect the tractive force per unit load and thus the cost of transportation.

By tractive force is meant the force exerted by a team in drawing a load over a road, and it is usually expressed in pounds per ton. The resistances to be overcome, called tractive resistances, are due to the load itself and the wagon carrying it. The general term tractive resistance, as applied to wagon haulage, may be separated into three parts: (1) Axle friction, (2) Rolling resistance, and (3) Grade resistance; and from this consideration the most advantageous condition of road transportation may be determined.

Axle Friction. Not very much is definitely known concerning this factor in wagon haulage, not only because of the few experiments made for its determination, but because of its relatively small importance as compared with the other resistances.

Those experiments that have been made, however, seem to check fairly well similar values obtained with railway car journals and in machines.

Axle friction depends upon the nature of the rubbing surfaces, *i.e.*, the material of which the hub and axle are made, upon the degree of lubrication, and the nature of the lubricant. With poor lubrication, this factor will be from two to six times the value obtained with good lubrication. In car journals, at least, the axle friction is dependent to some extent upon both velocity and temperature. That it varies inversely as some function of the pressure is known, but the exact relation has never been determined. According to Baker, for light carriages when loaded, the coefficient of friction is about 0.020 of the weight on the axle, for heavier carriages 0.015, and for common American wagons 0.012; or for the above carriages, from 3 to 4½ lbs. of tractive force per ton of weight on the axle may be charged to axle friction. As the diameter of the axle is decreased, and that of the wheel increased, the friction resistance may be diminished, but it should be observed that an undue decrease in the cross-section of the axle increases the axle pressure per unit area, causing excessive heat and wear.

In train resistances, the coefficient of resistance, in pounds per ton due to axle friction, has been found to be equal to the product of the coefficient of friction times the diameter of the axle, divided by the diameter of the wheel, multiplied by the number of pounds in a ton.

Coefficient of resistance =

$$\frac{\text{coefficient of friction} \times \text{diameter of axle}}{\text{diameter of wheel}} \times 2,000$$

Rolling Resistance. This is made up of several components but is due principally to the fact that, no matter how perfect the road's surface, the wheel of a vehicle will always sink to some extent into the metal, and it is thus always in the act of rolling

up a small incline. This of course is less in the case of the wheels of a locomotive on steel rails than in that of an ordinary cart hauled over an average road, but it exists in the former as well as in the latter.

The tractive force required to overcome this resistance might be found by the following demonstration. In Fig. 1, let VDR be

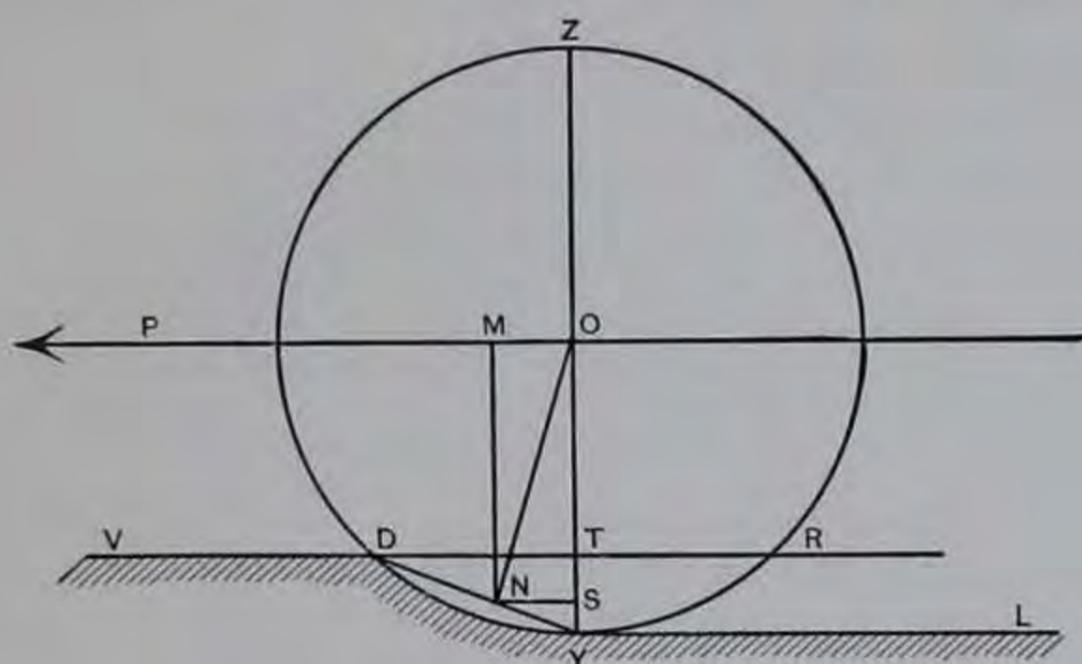

FIG. 1.

the original and natural surface of the road, O the centre of the wheel ZYD, TY the depth to which the wheel has sunk into the road metal, and P the direction of the motive force.

The submerged portion of the wheel is DY, of which it may be assumed that the arc corresponds with the chord. The resistance to penetration then is a maximum at Y, zero at D, diminishing with the depth of depression, and may be represented by an isosceles triangle with the centre of gravity at N, located one-third the distance YN from the base Y. This is also the centre of resistance and pressure of the load measured in direction and intensity by OS. The tractive force is measured by NS or MO. Since the depth TY is small, OS may be assumed equal to the radius of the wheel OY, and NS as one-third of the one-half chord DT. It follows then that if W = the load, T.F. = the tractive force, and R = radius of wheel,

$$W:T.F. :: OY:\frac{DT}{3} :: R:\frac{DT}{3}$$

and

$$\text{the resistance to traction} = \frac{W \times \frac{DT}{3}}{R}$$

but

$$DT = \sqrt{ZT \times TY}$$

and therefore the tractive force,

$$MO = \frac{1}{3} \times \frac{W \sqrt{ZT \times TY}}{R}$$

On the other hand, the power required to draw a wheel over an obstacle such as a stone may be determined as follows. Let O be the centre of the wheel, YZ the road, S the obstacle, and P the direction of the motive force OM . This is the force necessary to draw the wheel to the point S . The moment of the

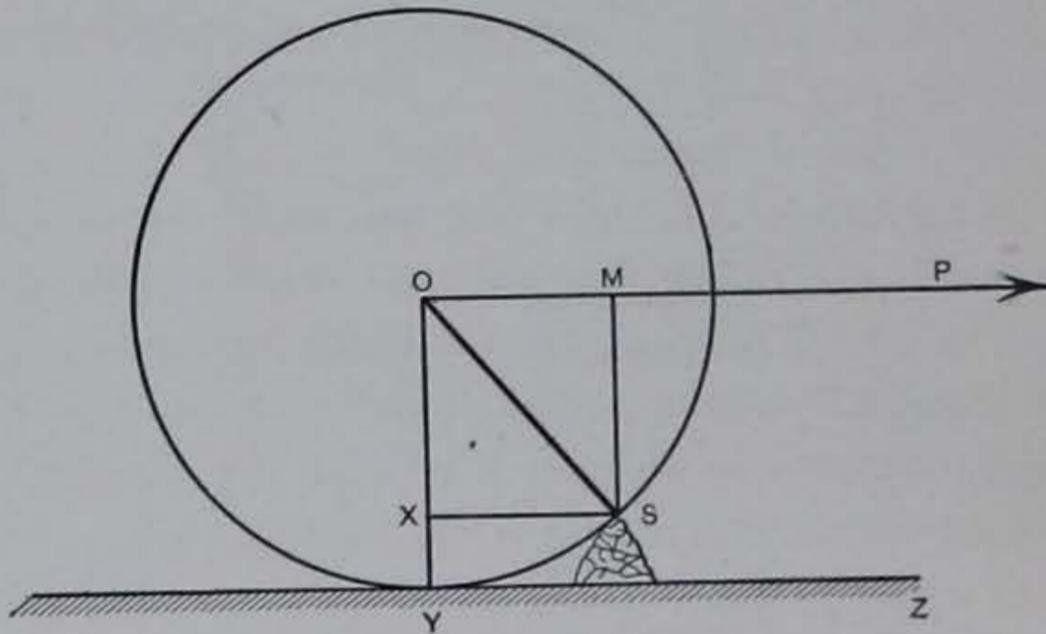

FIG. 2.

tractive force is equal to the force OM times its lever arm MS . But the weight of the load is acting in the direction OY and is represented in intensity by OX ; its lever arm is therefore equal to XS . For a condition of equilibrium $XS \times OX = OM \times MS$. If OM be represented by P and OX by W , then the tractive force

$$P = W \frac{XS}{MS}$$

The various components of rolling resistance affecting its value are: (a) The diameter of the wheel; (b) The width of the tire; (c) The speed; (d) The presence or absence of springs, and (e) The road surface.

THE DIAMETER OF THE WHEEL. Experimentally it has been determined that the diameter of a wheel affects the rolling resistance in some inverse ratio. This may be accounted for by the fact that the smaller wheel makes a deeper depression in a road than the larger, and therefore requires greater effort to haul it out. The previous figure gives the following solution:

$$P \times MS = W \times XS \text{ or } P = W \frac{XS}{MS}$$

$$XS : MS :: \tan XOS : 1 \quad (\text{dividing by } MS)$$

$$\tan XOS = \tan 2(SYZ)$$

$$\therefore P = W \tan 2(SYZ)$$

But as the SYZ increases inversely as the diameter of the wheel, the value of P will vary in like manner, and large wheels are hence better than small ones.

M. Morin experimenting upon the effect of diameter found that on a given road and with a given load, a 6 ft. 8 in. wheel had but little effect upon the road surface; that a 4 ft. 9 in. wheel cut deep ruts, and that a 10.5 in. wheel cut still deeper ruts.

At Bedford, England, in 1874, it was shown what effect the diameter of a wheel exerted upon the tractive force, when it was demonstrated that a pull of 1 lb. could move a load of 35.1 lbs. resting on a wheel 3 ft. 5 ins. in diameter, whereas the same force could move as much as 58.7 lbs. on a wheel 5.0 ft. in diameter.

Naturally the smaller wheels present the smaller bearing surface to the road, thus increasing the pressure per unit area for equally weighted vehicles. This increase frequently causes the depressions in, and undue wear of, the road's surface.

THE WIDTH OF TIRE. Perhaps no one of the above-mentioned components of rolling resistance has been discussed so frequently and so much as that of width of tire, in its effect upon

both haulage and road preservation. Generally the subject is approached from the standpoint of road preservation rather than that of decrease in tractive force; but both are worthy of careful consideration.

Narrow-tired wheels, like those of small diameter, are frequently required to carry a greater load per unit of bearing surface than is desirable, with the consequent effect that they not only increase the effort upon the horse, but, sinking deeper into the road, tend to destroy it more quickly.

Though it is generally considered that the adoption and use of broad tires will improve the road surface, the fact was mentioned by the Massachusetts State Highway Commission, in its Report of 1893, that results might not warrant such a change. Assuming that in the State of Massachusetts there were 50,000 vehicles requiring a change in the width of tire, at an average cost of \$20 a vehicle, this would mean an expenditure of \$1,000,000 for the alteration. It was pointed out that with this amount 200 miles of very excellent road could be built "of the kind that would not be affected by any width of tire." This is a point well taken, but it should be remembered that varying conditions require different consideration.

In New Jersey it is maintained by the Highway Commission that when a road is improved, immediately heavier loads are hauled on the same tires, causing ruts which hold water, with the consequent result of the disintegration of the foundation. Such ill effects can only be overcome by wider tires, thus decreasing the unit load and the destructive effects of the wheels. It has also been suggested that to supplement the good effect of road-rolling machines, four-inch tires be required on heavy trucks and that their owner's license be denied until such requirements be complied with.

To this effect, an act of the New Jersey Legislature dated March 24th, 1896, permits township committees to pass an ordinance allowing a rebate of taxes to owners or possessors of wagons

and carts with tires not less than four inches in width; and in Maryland, on toll roads, only one-half the rate is collected from drivers of broad-tired wagons.

Experiments show that with a uniform load and wheels of equal diameter, a tire 2.4 inches causes double the wear to the road that is produced by a tire 4.6 inches wide; but it may be questioned if tires broader than this have any advantage.

Tests made at the Missouri Experiment Station covering a period of two years, on macadam, gravel, and dirt roads, in all conditions, and on meadow, pasture, and ploughed land, both wet and dry, show the following results. The tests were made with a net load of 2,000 pounds in every case, a self-recording dynamometer being used to measure the tractive force.

“1. ON MACADAM STREET. As an average of 2 trials made, a load of 2,518 lbs. could have been hauled on the broad tires (6 ins.) with the same draught that a load of 2,000 lbs. required on narrow tires (1½ ins.).

“2. GRAVEL ROAD. In all conditions of the gravel road, except wet and sloppy on top, the draught of the broad-tired wagon was very much less than that of the narrow-tired wagon. Averaging the 6 trials, a load of 2,482 lbs. could be hauled on the broad tires with the same draught required for a load of 2,000 lbs. on the narrow tires.

“3. DIRT ROAD. (a) When dry, hard, and free from ruts and dust, 2,530 lbs. could have been hauled on the broad tires with the same draught required for 2,000 lbs. on the narrow tires. (b) When the surface was covered with 2 or 3 ins. of very dry loose dust, the results were unfavorable to the broad tire. The dust on the road in each of these trials was unusually deep. (c) On clay road, muddy and sticky on the surface and firm underneath, the results were uniformly unfavorable to the broad tires. (d) On clay road, with mud deep and drying on top, or dry on top and spongy underneath, a large number of tests showed uniformly favorable to the broad tire. The difference amounted to

from 52 to 61 per cent, or about 3,200 lbs. could have been hauled on the broad tires with the same draught required to draw 2,000 lbs. on the narrow tires. In this condition of road the broad tires show to their greatest advantage. As the road dries and becomes firmer, the difference of the draught of the broad and narrow tires gradually diminishes until it reaches about 25 to 30 per cent on dry, level, smooth dirt, gravel, or macadam road in favor of the broad tire. On the other hand, as the mud becomes softer and deeper, the difference between the draught of the two types of wagons rapidly diminishes until the condition is reached when the mud adheres to both sets of wheels; here the advantage of the broad tires ceases entirely, and the narrow tires pull materially lighter. (e) Clay road, surface dry, with deep ruts cut by narrow tires in the ordinary use of the road. In every trial the first run of the broad tire over the narrow-tire ruts showed a materially increased draught when compared with that of the narrow tire run in its own rut. The second run of the broad tires in the same track, where the rut is not deep, completely eliminated this disadvantage, and showed a lighter draught for the broad tire than the narrow tire showed in the first run. Where the ruts were eight inches deep, with rigid walls, three runs of the broad tire in its own track over the ruts were required to eliminate the disadvantage. Three runs of the broad tire over this track have in all cases been sufficient, however, to so improve the road surface that both the broad- and narrow-tired wagons passed over this road with less draught than the narrow tires did in the original ruts. In addition to the saving of draught, the road was made very much more comfortable and pleasant for the users of light vehicles and pleasure carriages by the few runs of the six-inch tire. Summing up all the tests on dirt roads, it appears that there are but three conditions on which the broad tires draw heavier than the narrow tires, namely, (1) When the road is sloppy, muddy or sticky on the surface, and firm or hard under-

neath; (2) when the surface is covered with a very deep, loose dust, and hard underneath; (3) when the mud is very deep and so sticky that it adheres to the wheels on both kinds of wagons. It appears that the dust must be extraordinarily deep to show a higher draught from the broad tires than from the narrow tires. The three conditions just named, therefore, are somewhat unusual and of comparatively short duration. Through a majority of days in the year, and at times when the dirt roads are most used, and when their use is most imperative, the broad-tired wagons pull materially lighter than the narrow-tired wagons.

"4. A large number of tests on meadow, pasture, and stubble-land, corn ground and ploughed ground in every condition, from dry, hard, and firm to wet and soft, show without a single exception a large difference in draught in favor of the broad tires. This difference ranged from 17 to 120 per cent.

"5. It appears that 6 ins. is the best width of tire for a combination farm and road wagon, and that both axles should be the same length, so that the front and hind wheels will run in the same track."

It is therefore evident that wide tires not only tend to diminish the draught under most conditions, but that they also aid in the preservation of the road surface.

SPEED increases the rolling resistance, as the shocks, due to irregularities in the surface, occur with greater frequency. On a uniformly smooth surface, MM. Morin and Dupuit found that the resistance to traction is independent of the speed, but on ordinary roads or pavements it has been shown to vary as some power of the velocity. Naturally it is dependent upon the surface and also upon the presence or absence of springs.

SPRINGS decrease the shock to which the vehicle is subject in rolling over rough surfaces, and hence diminish the tractive force as well as wear and tear to wagon and road. For smooth roads, this will vary less than for rough. Like speed, it is but a small factor in rolling resistance.

ROAD SURFACE. The effect of the road surface upon rolling

resistance and tractive force is quite evident in the two extreme cases of a railway and an ordinary dirt road. It requires no demonstration to be convinced that for the same expenditure of energy, other things being equal, a very much heavier load may be hauled on the former than on the latter. In other words, the smoother and harder the road for a level surface, and disregarding the question of foothold, the greater the load that may be hauled for a unit of power. Smoothness and hardness not only reduce tractive force, but produce comfort, and diminish shock, wear and tear on road, vehicle, and animal.

The following figure represents graphically the conditions resulting from various pavements.

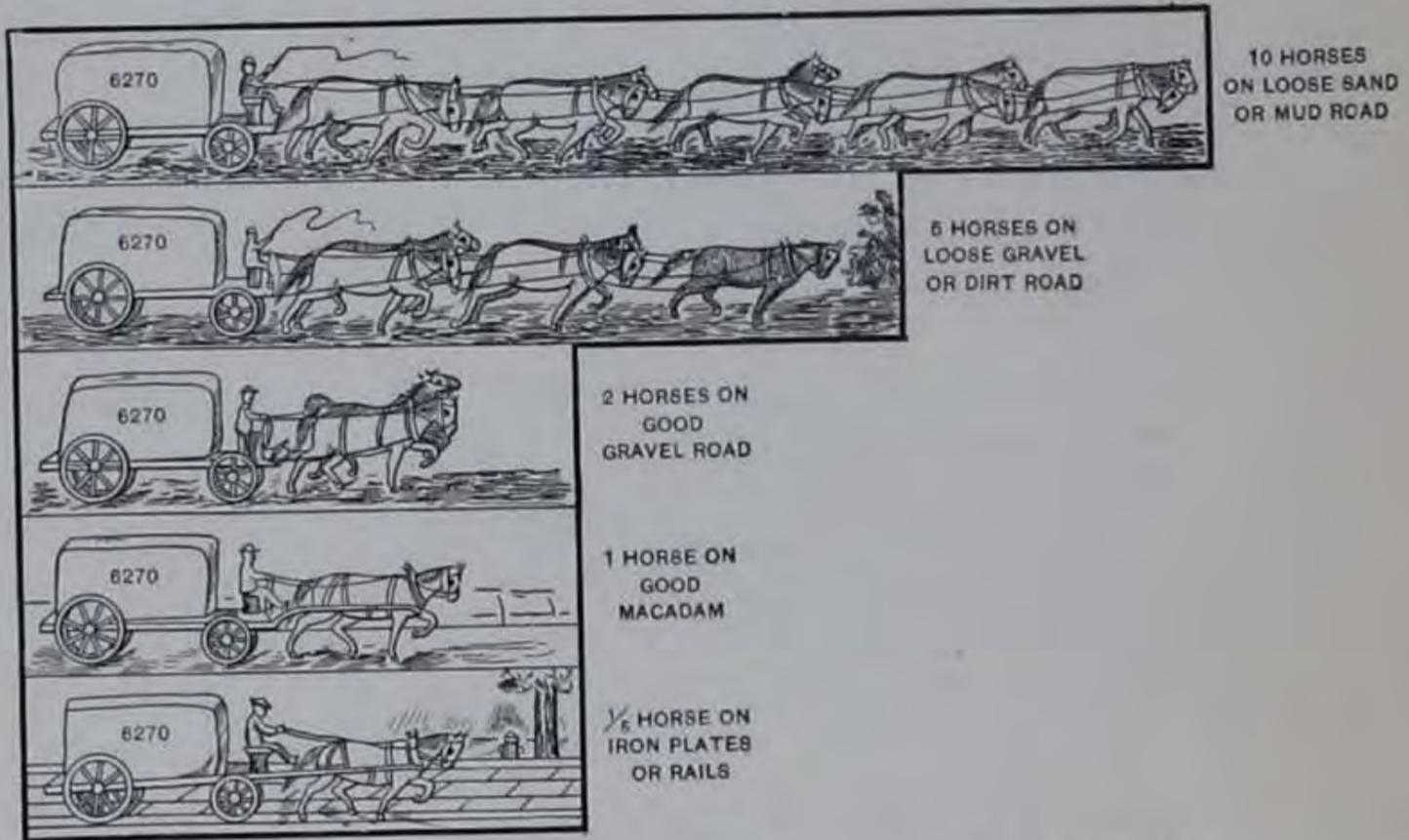

FIG. 3.—Showing the Effect of Road Covering on Tractive Force.

As showing the effect of surface upon tractive force, the following table from Sir John McNeill is given:

Kind of Road.	Tractive Force. Pounds Per Ton.
Well-made block pavement.....	33
Telford or macadam.....	46
Old flint road.....	65
Loose gravel.....	147

The results tabulated below are from the tests made by M. Morin:

Kind of Road.	TRACTIVE FORCE.			
	Carts, 3 Miles per Hour. Pounds per Ton.	Wagons 2 Tons, 3 Miles per Hour. Pounds per Ton.	Carriages with Springs, 3 Miles per Hour. Pounds per Ton.	Carriages with Springs, 6 Miles per Hour. Pounds per Ton.
New road with 5 ins. of gravel	166	222	250	
Earth road with $\frac{1}{2}$ in. of gravel	125	191	200	
Broken stone in best condition	27	37	42	48
Broken stone, much rutted and very muddy	105	143	166	200
Pavement, clean	11	30	35	53
Pavement, muddy	14	40	45	66

The following table from Rudolph Herring shows the effect of road surface on tractive force. The velocity in each case is three miles per hour.

Kind of Road.	Tractive Force.	
	Pounds.	Authority.
Loose sand	448	Bevan.
Loose gravel (deep)	320	"
Loose gravel (4 ins.)	222	Morin.
Common gravel road	147	McNeill.
Good gravel	88	Rumford.
Hard rolled gravel	75	Minard.
Ordinary dirt road	224	Bevan.
Hard clay	112	"
Hard, dry, dirt road	89	Morin.
Macadam, little used	140 to 97	"
Bad macadam	160	Gordon.
Poor macadam	112	Navier.
Common macadam	64	Peidounet.
Good macadam, wet	75 to 42	Morin.
Best French macadam	45	Navier.
Very hard and smooth macadam	46	McNeill.

Kind of Road.	Tractive Force.		Authority.
	Pounds.		
Best macadam.....	50		Rumford.
“.....	49 to 37½		Gordon.
Best macadam.....	52 to 32		Morin.
Cobblestone, ordinary.....	140		Kossack.
Cobblestone, good.....	75		“
Belgian block.....	56		McNeill.
Belgian block in Paris.....	54 to 34		Navier.
Belgian block.....	37½		Rumford.
Belgian block, good.....	34½		McNeill.
Belgian block.....	50 to 26		Morin.
Stone block, ordinary.....	90		Minard.
Stone block, good.....	45		Rumford
Stone block, London.....	36		Gordon.
Asphalt.....	17		“
Granite tramway.....	13½		“
“.....	12½		“
Iron railway.....	11½		“
“.....	8		Lecount.

The results of traction tests given below were made by the Office of Road Inquiry of the U. S. Government.

Kind of Road.	Tractive Force.	
	Pounds.	
Loose sand (experimental).....	320	
Best gravel (park road).....	51	
Best clay.....	98	
Best macadam.....	38	
Poor block pavement.....	42	
Cobblestone.....	54	
Poor asphalt.....	26	

In the line of relative tractive resistance on brick and asphalt pavements few tests have yet been made, so that the following results obtained from tests made by the Department of Civil Engineering of Iowa State University are of some value.

TRACTION TESTS ON BRICK AND ASPHALT PAVEMENTS.

Character of Pavements.	Tractive Resistance. Pounds per Ton.
<i>Brick Pavement.</i>	
One course, sand-filled, much worn and broken.....	58
On concrete, sand-filled, much worn and rough.....	43.3
Same as above.....	37.6
On concrete, sand-filled, dirty, well worn.....	33.3
On concrete, nearly new, cement-filled.....	31.7
On sand, sand-filled, condition fair.....	29.1
New, sand-filled.....	37.2
Old, tar-filled, smooth, clean.....	28.2
Old, cement-filled, clean, smooth.....	25.4
Clean.....	16
Dirty.....	19
<i>Asphalt Pavement.</i>	
New, quite dirty.....	26.7
New, clean, smooth.....	24.0
New, clean, smooth.....	23.3
Old, clean, much used.....	29.1
New, clean, little used.....	24.2
Old, dirty, little used.....	39.9
Old, clean, very little used, pitted.....	67.8
Same as above, but colder.....	36.5
Same as above after period of cold weather, dirty.....	34.4
Clean, new, very little used.....	55.5
Same as above, but colder.....	31.1
Same as above after period of cold weather, fairly clean.....	26.5
Block asphalt, one year old, much used, worn, clean.....	28
Clean.....	34

The above were all made with ordinary draught wagons.

TRACTION TESTS. The determination of values such as given above constitutes what is known as a traction test. Various instruments have been used to measure the amount of effort exerted by a horse in hauling a load over a road, with the object of learning which pavement permits of the largest load, and hence gives the cheapest cost of transportation.

In road construction, as in every other branch of engineering, it should be remembered that the question of cost is important—

if not the most important—and that good roads are represented by those over which loads may be transported for the least expenditure. To compare the cost of haulage it therefore becomes necessary to determine the effort exerted. The pioneers and authorities along this line were M. Morin, who experimented for the French government, and Sir John McNeill in England. The latter's results were published in 1848, while the former's appeared in 1843.

The more recent results of the experiments of the Department of Agriculture, made in 1895, are of distinct value. They were made on the roads of the United States Road Exhibit at the Cotton States and International Exposition in Atlanta, Ga., in 1895. The wagon and load were similar to those in daily use in the Southern States to demonstrate to the public the advantage of improved roads. Three kinds of roads were used, a modern macadam, a sand road, and an ordinary dirt road, the latter two being types of the more common roads in the South.

The macadam road was 300 ft. long, made up of six 50 ft. sections, varying in rise by 2 per cent increments, from a level to a grade of 10 per cent. The sand and the dirt roads were each 200 ft. long, divided into 50 ft. sections, varying in a similar manner from a level to a grade of 6 per cent. The tests therefore show the results not only of road surface, but grade as well.

The macadam road, 12 ft. wide, had a natural clay subgrade, which was well rolled. On top of this 4 ins. of 2 in. blue Trenton limestone was placed, followed by a course of 2 in. screenings, each being subjected to the action of a road roller.

The sand road was 12 ft. wide also, consisting of 6 ins. of river sand placed on a bed of natural clay, neither the bed nor the surface being rolled.

The dirt road was made of natural earth. To approximate general conditions, it was thoroughly wetted and had a heavily laden narrow-tired wagon passed over it to form ruts and depressions.

To measure the force applied to haul the wagon over these roads with varying grades, a simple modification of the spring balance was used with a large index finger moving over a graduated arc to show the pull in pounds and having one end attached to the wagon and the other to the team. The record was simply by the eye, and showed that even for the smoothest possible macadam the force of traction was not constant, but changed continually within a limit of 50 lbs. With dirt roads the force varied from zero to 700 lbs. in a gross load of 3,000 lbs., and showed that it was applied in a manner to represent a succession

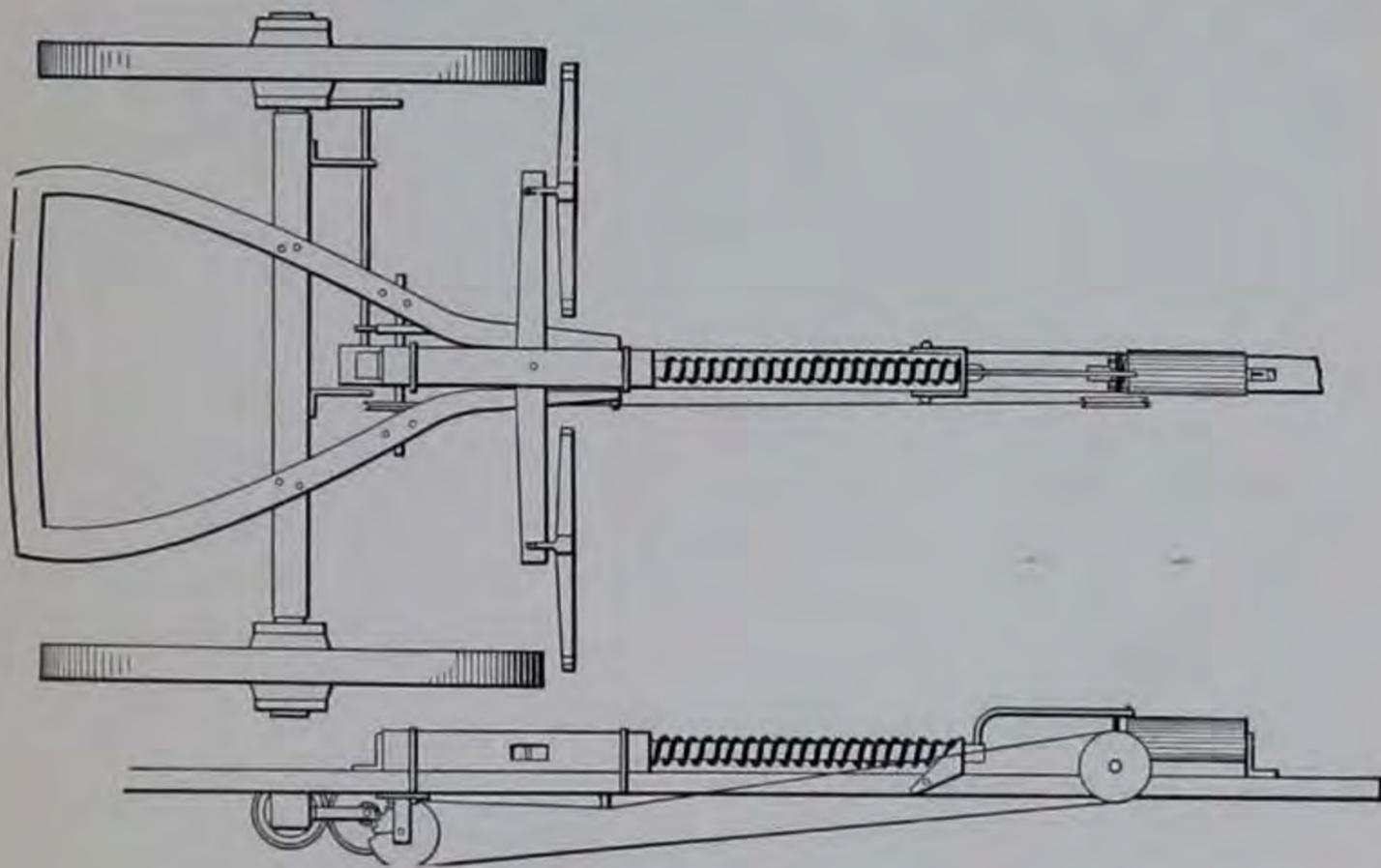

FIG. 4.

of rapid and violent jerks. On heavy, smooth grades the force was more nearly constant, as might be expected; while to start the load under any conditions it required about four times the force necessary to haul it.

From these preliminary observations the following conclusions were drawn: On the smoothest road a team is subject to a jerking motion which greatly fatigues. This is greatest on a dirt road

because the smoother the surface the less the effect of such action. It requires about four times the effort on a level dirt road as upon a level macadam. Hard roads reduce the tractive force, and sand roads increase the pull enormously.

Supplementing these tests, a tractograph was used to determine and record the force applied. Fig. 4 shows it in position on the shaft of the wagon. It consists of an arm, placed longitudinally along the pole, holding a pencil point resting on a stationary cylinder covered with a sheet of paper. By means of the connections shown, the cylinder was made to revolve so that it completed 1 revolution in a distance of 1,316 ft. The spring was standardized against known weights varying by 100 lbs. from zero to 1,200, and hence the compression of the spring per unit became known. From these facts it was possible to have a sheet of paper divided into spaces corresponding to pulls of 10 lbs., and into other spaces corresponding to distances of 100 ft., which made known the exact amount of pull and the place at which it was applied. The compression of the spring due to a pull on the double-trees caused the pencil point to move forward on the cylinder, and thus make the record. The diagrams following show the records obtained: Fig. 5, on an asphalt street; Fig. 6, on a smooth macadam road in good condition; Fig. 7, on a smooth dirt road; and Fig. 8, on a macadam road ascending a hill of 10 per cent grade.

The asphalt was not in good condition, being rough and uneven, as is quite conclusively shown by the irregularity of the record.

The macadam pavement was in excellent condition.

The dirt road was also in good condition; dry, firm, and smooth. It crossed the macadam pavement in two places, and this is shown by the two high points in the curve, being due to the fact that the team stopped on either side of the pavement.

Fig. 8 shows the effect of a steep grade upon the tractive

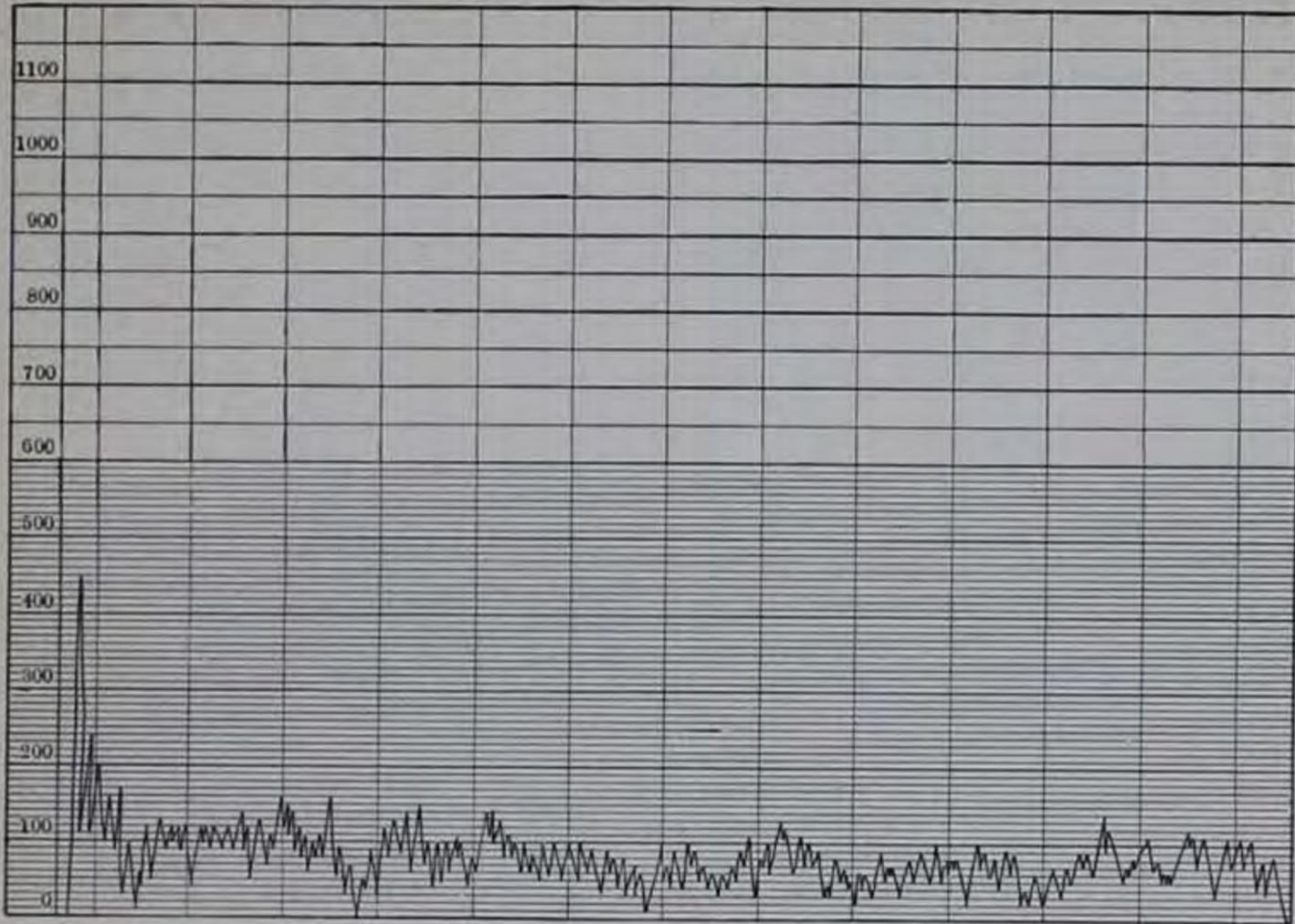

FIG. 5.—Asphalt Pavement.

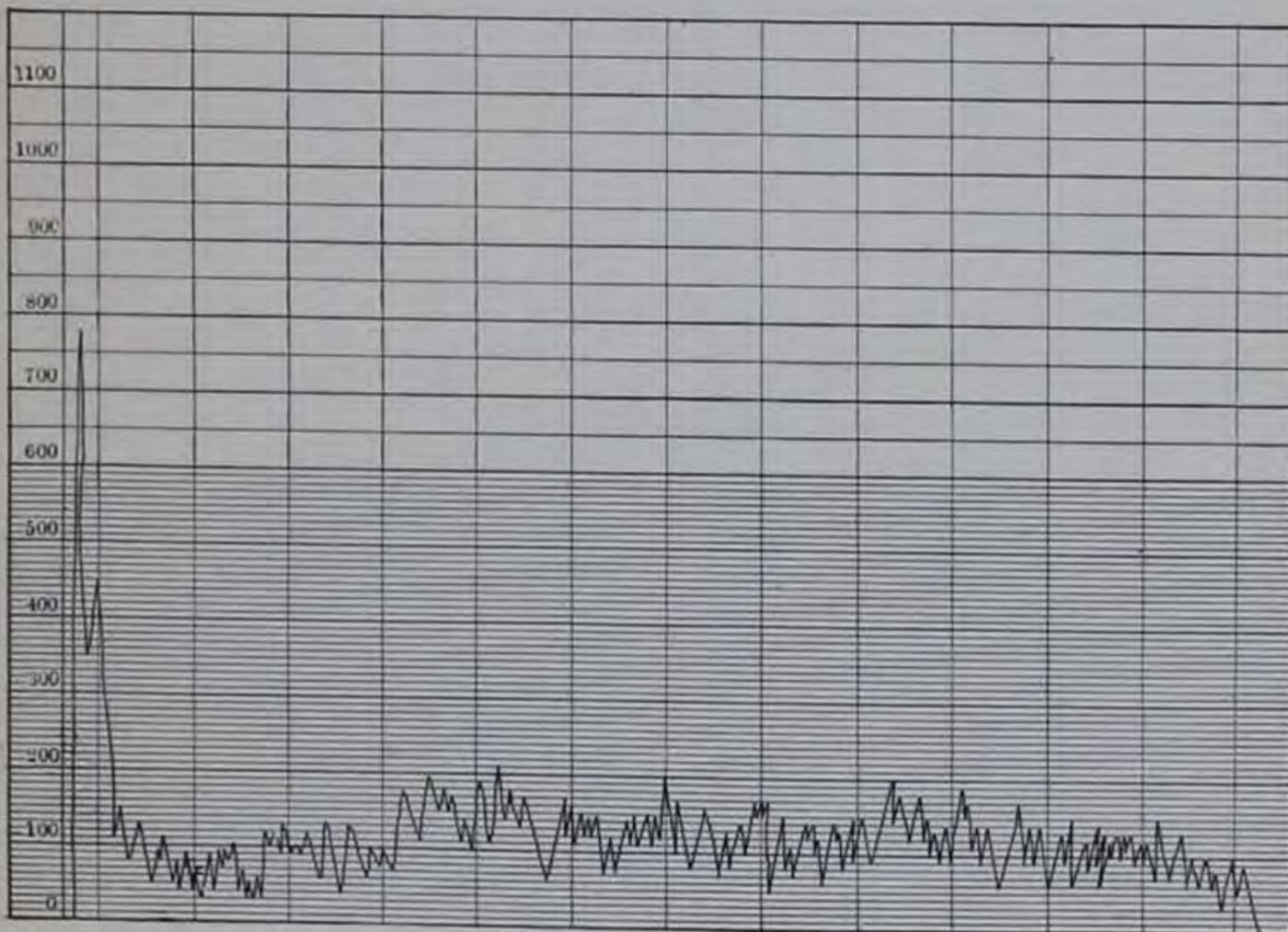

FIG. 6.—Smooth Macadam in Good Condition.

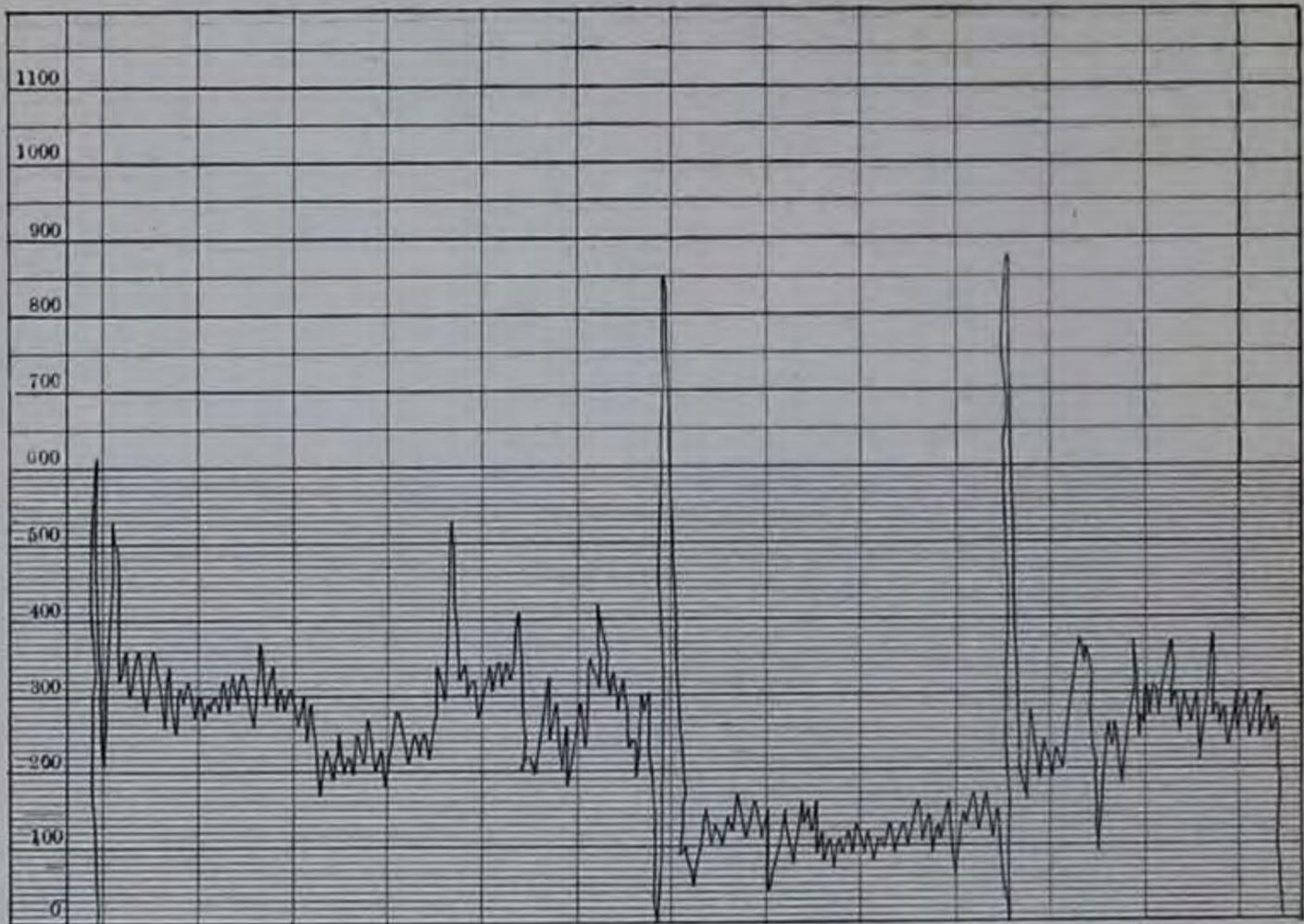

FIG. 7.—Smooth Dirt Road.

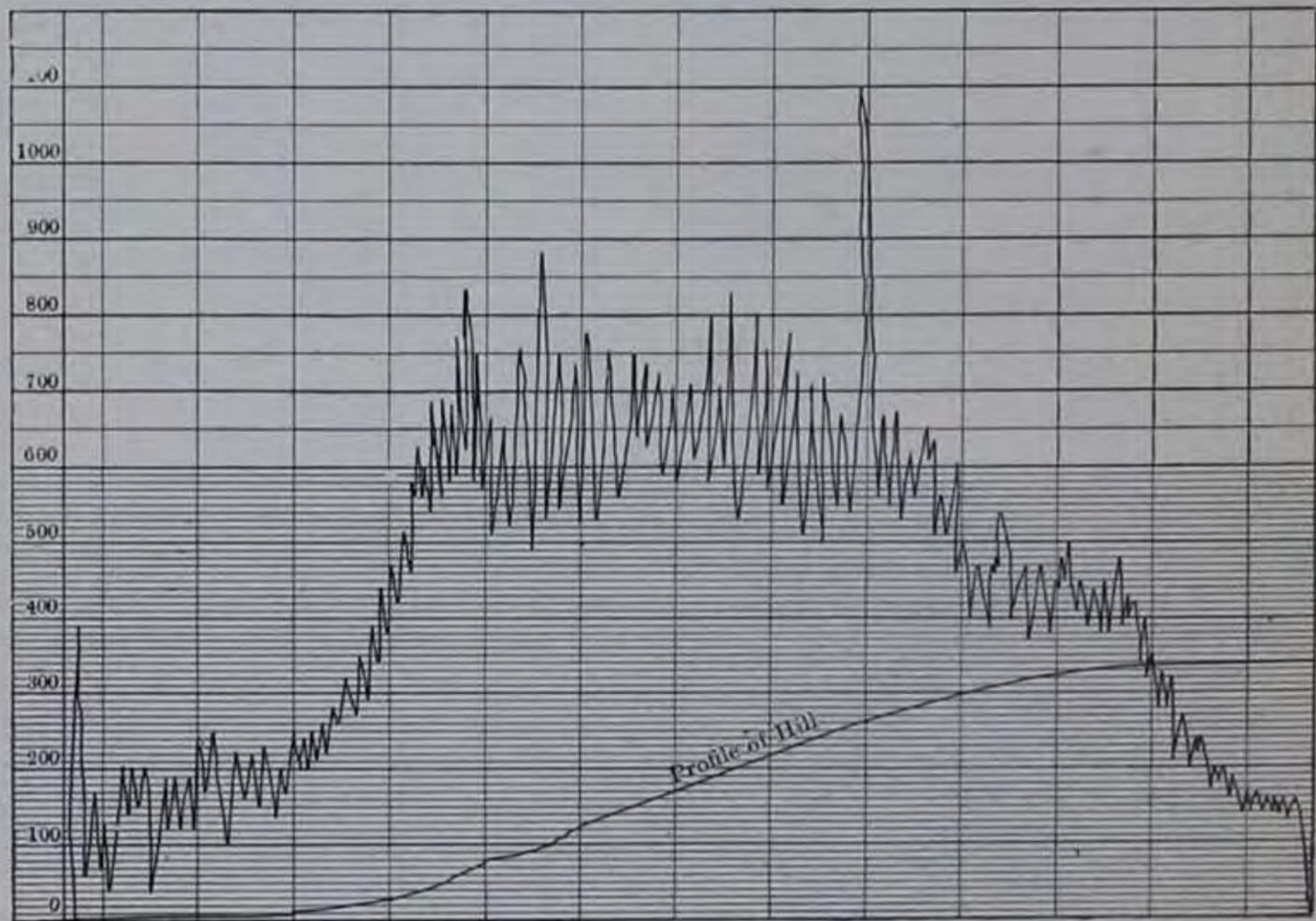
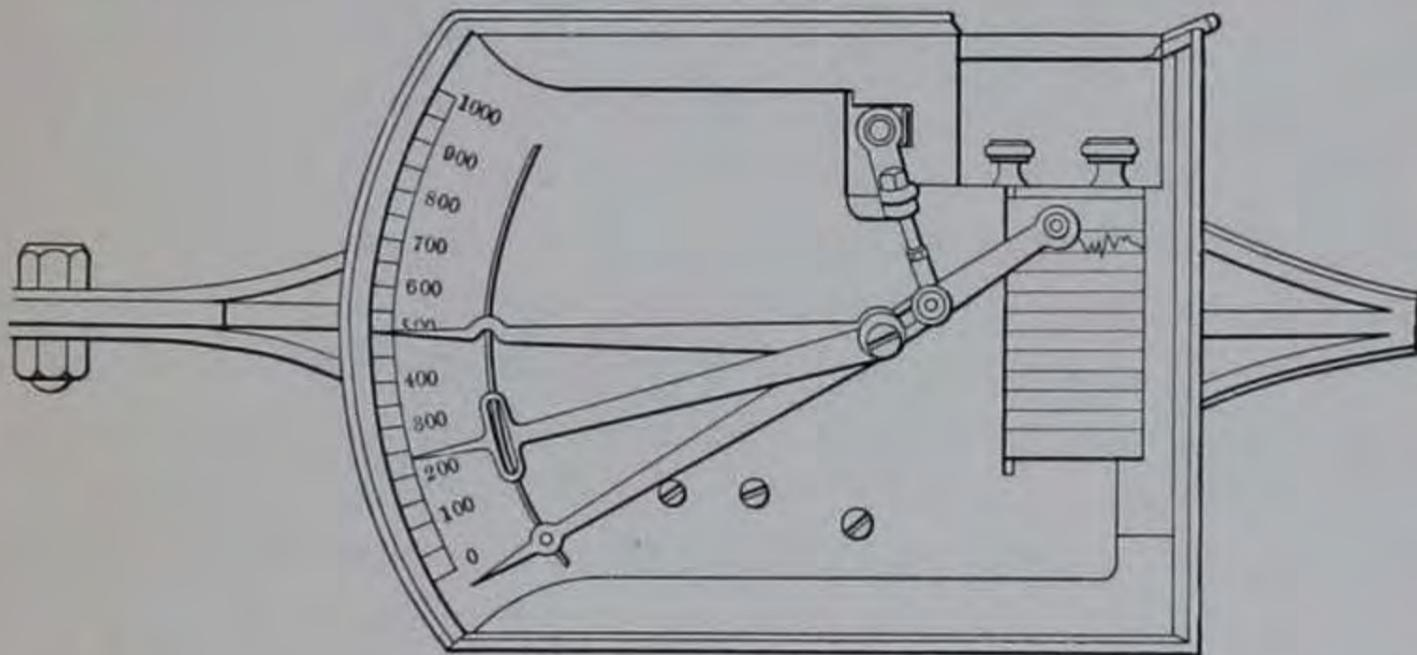
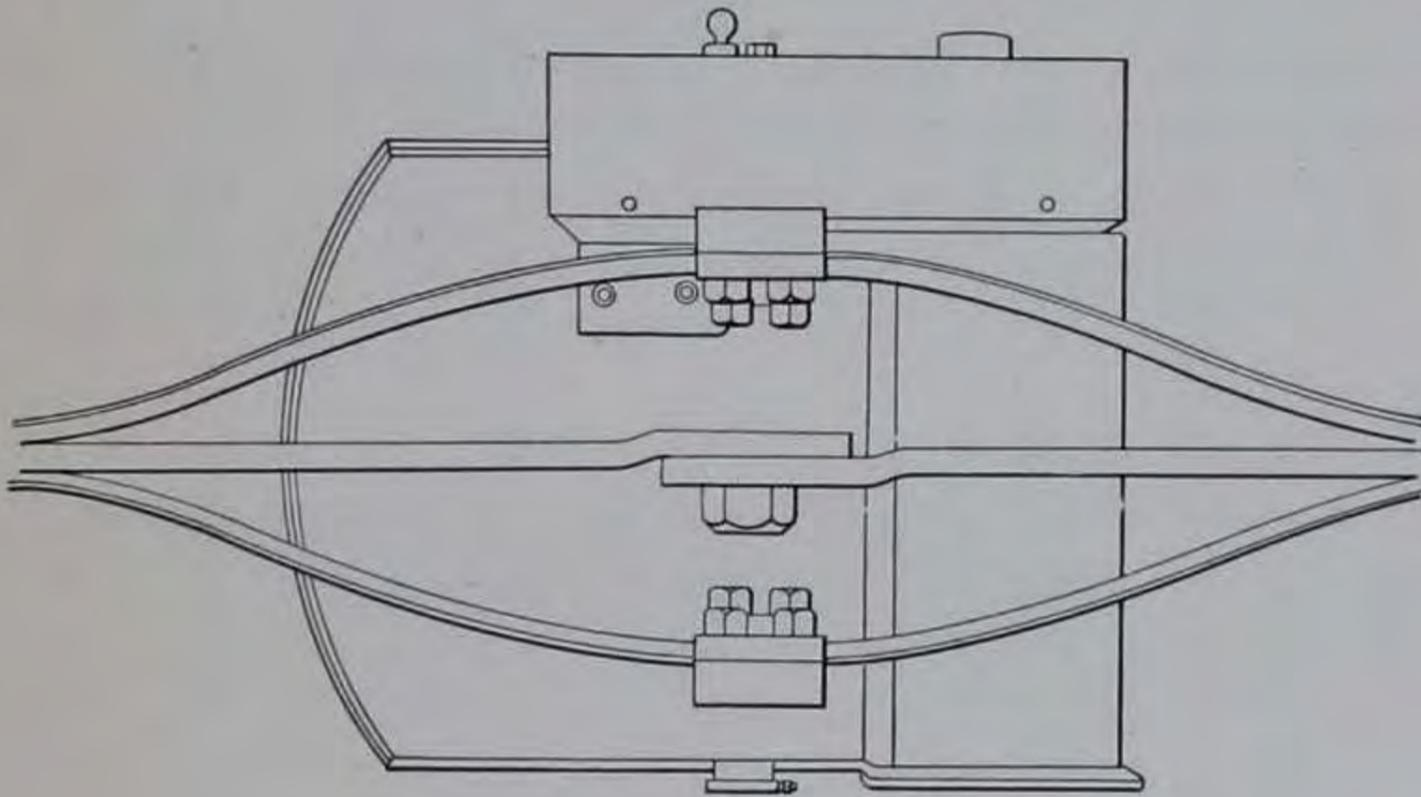

FIG. 8.—Macadam Road Ascending a 10 Per Cent Grade.

force, and under the existing conditions the extremely irregular curve is due to the fact that the team required continual urging to ascend the hill at all. Compared to the diagram of the level



TOP VIEW.



BOTTOM VIEW.

FIG. 9.—Baldwin Dynograph.

stretch, it indicates that about seven times the force was required on the former as upon the latter.

Under all conditions, the high points of the curves at the start

indicate that from four to eight times the effort to haul the load was required to set it in motion.

If the average amount of tractive force for each road is desired, it may be computed by taking the area between the zero line and the curve and dividing by the distance. From such calculations it was found that the smooth asphalt street required 26 lbs. per ton, the smooth macadam road 38 lbs. per ton, the smooth dirt road 96 lbs. per ton, and on the 10 per cent grade 136 lbs. per ton.

A similar instrument for measuring the tractive force and recording it automatically is the Baldwin dynograph, a cut of which is shown.

This instrument consists essentially of two flat springs with ends connected, and centres separated from each other by the small distance shown. One end of the springs is attached to the wagon and the other end to the team. Any force exerted by the team tends to draw the centres of the springs together, and this contraction is recorded, first by the small pencil point moving over the revolving cylinder, which carries a graduated sheet of paper, and second by two index arms which show against the scale the maximum number of pounds pull, and also an approximate average.

Grade Resistance. Aside from the question of drainage, the ideal road should be as nearly level as possible, since under these conditions it favors the load neither going or coming and presents less resistance to traction.

To calculate what this resistance is, let us assume in Fig. 10 that G is the centre of gravity of the load; then GA is the direction and amount of the weight, while BG represents the force pressing against the inclined surface DE. The line EF represents the rise per unit of length DF, which is the horizontal. From the two similar triangles we have $GA : AB :: DE : EF$; but GA is the weight of the load, DE is the length of road, and EF is the rise.

Representing these by W , l , and r , we have,

$$W : AB :: l : r \text{ or } AB = W \frac{r}{l}$$

but AB is the resistance due to grade.

Or we may write the formula

$$R = F + aW.$$

Where R = force required to draw the load on an incline,

F = force required to draw the load on the level,

a = the grade expressed as a fraction,

and W = the weight of the load in pounds.

Regarding the effect of grade, the Massachusetts State Highway Commission, in its Report for 1901, says: "By far the most serious defect in the old town highways is the heavy grades.

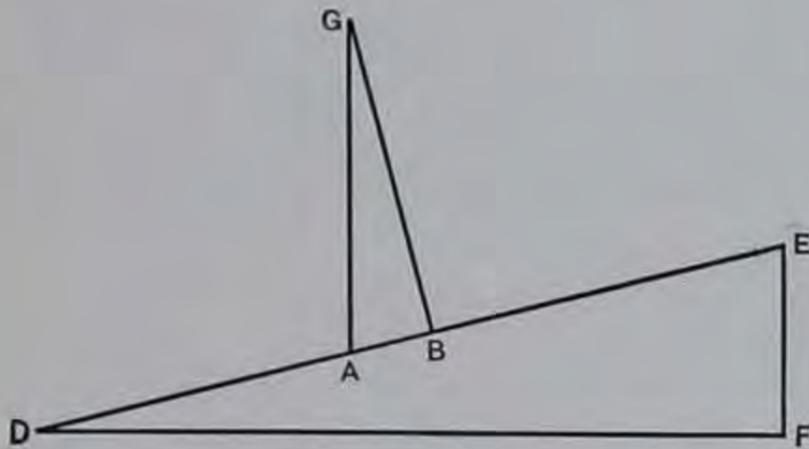

FIG. 10.

These are not only a tax on the user, but they are a constant and burdensome cost to the municipalities having to care for them. Taken as a whole, no one improvement makes a better return for the money invested than the cutting down of hills. Whatever is done in this direction is a permanent benefit, as by carefully grading a road throughout its entire length between centres of population or business, the possible load is increased, notwithstanding no particular effort be made to improve the surface."

The table below shows the effect of grade on the best macadam roads in the variation of the tractive force.

Rate of Inclination.	Tractive Force Pounds per Ton.
Level.....	38
1 in 500 = 0.2 of 1 per cent.....	42
1 in 100 = 1.0 per cent.....	58
1 in 80 = 1.25 per cent.....	63
1 in 60 = 1.66 per cent.....	71
1 in 50 = 2.0 per cent.....	78
1 in 40 = 2.5 per cent.....	88
1 in 30 = 3.33 per cent.....	104
1 in 25 = 4.0 per cent.....	118
1 in 20 = 5.0 per cent.....	138
1 in 15 = 6.66 per cent.....	171
1 in 10 = 10.0 per cent.....	238

This is graphically represented in the following cut.

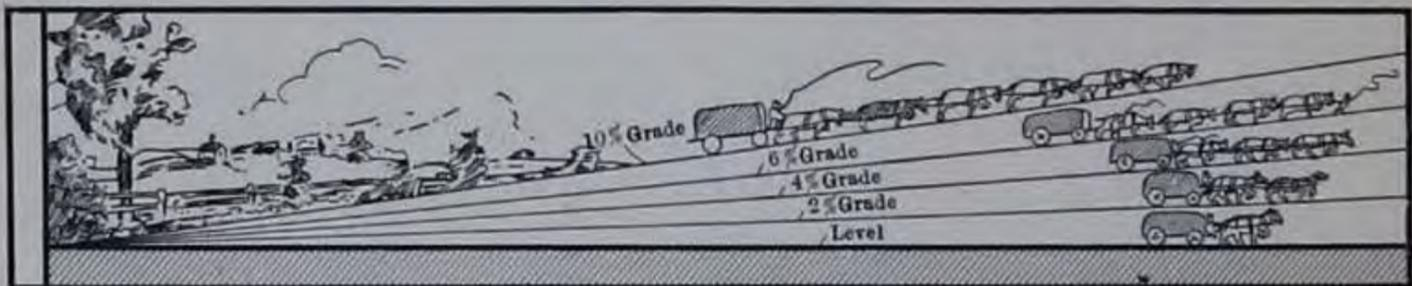

FIG. 11.—Effect of Grade on Tractive Force.

In any case the maximum grade is that which determines the load that may be hauled over any section of a road, and hence it should always be the object to reduce grade to a minimum. Furthermore, a horse's effective power for hauling rapidly diminishes going up inclines, since it is compelled to overcome the increased resistance of gravity due to its own weight, as well as that due to the load itself. It should be taken into consideration, however, that for a short distance a horse is able to exert several times its normal tractive pull, and it should be remembered also that the smoother and harder the surface the poorer may be the foothold, and consequently the less the power that a horse may exert.

This is quite conclusively demonstrated by the following table taken from Baker, showing the effect of grade and road covering

CHAPTER II

EARTH ROADS

ALMOST without exception, and naturally so, the highways of the United States have had their beginning as dirt roads. Fortunately, however, such preliminary preparation or construction usually serves very well as a base upon which a better surface may be built, though more frequently than not when improvements are to be begun it is not only the surface which needs them, but the line, grade, and drainage as well.

The rectification of line and grade necessitate the straightening of the alignment by the elimination of curves and bends, and of cutting down hills and filling in valleys, while the improvement in the drainage consists in the application of the fundamental principles governing the flow of water.

To-day most of the roads of this country are in their original condition, for dirt roads are the cheapest to construct, material is always at hand, the maintenance afforded is apparently inexpensive, they require no skilled labor, and usually the economic and social conditions will not warrant a greater outlay for superior ones.

Those roads that have been improved are only a small proportion of the whole. In the East, for example, more than fifty per cent of the highways are absolutely without improvement of surfacing, while in the more recently settled States of the West and Middle West this figure is greatly exceeded. Thus in Illinois, over ninety-seven per cent of the roads are of dirt. These facts would seem to indicate the importance of properly building and caring for roads of such a character.

Earth roads are the forerunner of gravel, macadam, and other

improved pavements, and remain as they are only so long as they successfully satisfy the demands of traffic or until it is appreciated that permanent good roads are much less expensive to build and maintain than any other kind.

Roads of earth as usually constructed possess a great many inherent qualities which unfit them for satisfactory highways. Many cases exist where the location of the road has been made with but little regard for either grade or distance; but, aside from these drawbacks, often the best has not been made of available materials or existing conditions.

Drainage, perhaps the most important factor in the maintenance of a road, has more often than not been neglected; or, if a realization of its import has been had, quite frequently the system adopted has thwarted the object it was intended to accomplish.

Considering three of the more necessary requisites—hardness, smoothness and ability to shed water—it will be seen that in all three of these, roads of dirt are lacking, and as a consequence, being easily broken up by heavy loads or narrow tires, and always in a condition to absorb moisture that may fall upon them, they are dusty in summer and muddy in wet weather. Both of these conditions greatly increase the tractive force, as the previous chapter shows while the presence of depressions and irregularities in the surface permits water to collect, only to disappear through evaporation or by sinking into the subgrade which it is one of the functions of the covering to prevent. Furthermore, because they are so retentive of moisture, at the breaking up of cold weather when the frost is leaving the ground earth roads are seriously affected, with the consequent tax upon traffic. If the drainage system is properly planned neither the muddy state after rain or snow nor the broken-up condition so noticeable in spring resulting from the frost could occur.

When a dirt road is kept in good order, which can only be

secured through constant supervision, during the greater part of the year it will serve quite satisfactorily for the sort of traffic it is intended to carry, *i.e.*, light traffic, but even so it should be remembered that the tractive force expended on such a road is double that required under similar circumstances on a gravel pavement and four times that on a macadam.

Generally speaking, little technical skill is used in the design and construction of dirt roads, while frequently they are formed simply by a furrow being ploughed on each side of the centre line to provide side ditches, with the material so excavated thrown into the middle of the roadway for the purpose of giving crown and securing surface drainage, the traffic being supposed to consolidate it. This may be supplemented by a road machine to shape the wagonway and side ditches, with grading and rolling to follow, or, where the material is stony, by pick and shovel, as it is impossible to use the machine with such material.

Sometimes the entire roadway is ploughed and then shaped with the road scraper or road machine, but as this leaves the material soft and yielding, traffic immediately produces ruts in which water settles, making the surface muddy, and sinking into the subgrade.

The compacted soil wherever possible should remain undisturbed, either in construction or repairs as it is already hard and firm, and will make a better roadbed and absorb less moisture than when it has been loosened. When, however, the surface is uneven and worn, a plough may often be used to advantage to take off the irregularities. The material so removed should be wasted, however, so that it may not again reach the road or side ditches as it has lost its binding properties. Fresh loam, free from vegetable matter, should be substituted in its stead to bring the road to the proper cross-section. Loam is by far the best material for making such repairs, as it binds well, and is neither too retentive of moisture, as is clay on the one hand, nor does it permit water to soak through, as does sand on the other.

It is needless to say that such construction as indicated above frequently fails of its purpose. For satisfactory results the wearing surface of a road must be in effect a roof; that is, the section in the middle must be the highest part and the travelled roadway should be made, by consolidation, as impervious to water as possible, so that the rain or melting snow will flow freely and quickly into the gutters alongside.

Probably the best shape for the cross-section of an earth road is an arc of a circle with a gradual fall from the centre to the sides of about one in twenty, after the surface has been thoroughly rolled or compacted by traffic. Such a surface can be constructed and repaired with a road machine, and a roller can be used upon it to good advantage. When the surface is not kept smooth and compact the crown should be a little steeper than 1 in 20, but should normally never exceed 1 in 10. If the crown is too great the traffic will follow the middle of the road, which results in ruts and ridges that retard the prompt shedding of the water into the side ditches. Too much crown is as detrimental as too little.

In the construction of new roads, all vegetable matter, sod, roots, stumps, rocks, etc., should first be removed from the roadway, grading following this, and rolling with sprinkling for the purpose of consolidation finishing up the process. The line should be so carefully planned that a maximum grade of about five per cent need never be exceeded, except in mountainous districts where the topography is particularly difficult or rugged. The width of wheelway may vary from twelve to forty feet, depending upon the amount of traffic that is to make use of the thoroughfare.

Drainage. Dirt roads are, naturally, not ones where a great deal of money may be or usually is expended, either in their construction or maintenance and repair; but it is a fact that of the influences tending to make such roads fit for traffic or absolutely impassable, and therefore where money may be used to greatest advantage, drainage is by far of most consequence. This is frequently referred to by the remark that the three most important

factors in road building and maintenance are: 1st, Drainage; 2d, Drainage; and 3d, *More* Drainage; and is recognized by the fact that even in the most primitive roads ditches at the sides are generally provided to drain the subgrade and afford a waterway for that which, falling on the surface, is directed toward them by the transverse slope.

Drainage may be accomplished in three ways: 1st, Surface drainage; 2d, Sub-surface drainage; and 3d, Drainage through side ditches.

SURFACE DRAINAGE has for its object the directing of any water falling upon the road covering toward the sides as quickly as possible, so that none may be allowed to collect on the surface, there to form pools, produce mud, and gradually sink through to the subgrade, unless it be evaporated by sun and wind; and it is accomplished by crowning the road and keeping the surface firm, hard, and smooth, so that the water will easily and quickly run off.

By crowning is meant the elevation of the centre of the roadway above the sides: the smoother the surface the less this need be. Where ruts and holes exist, proper surface drainage is impossible, except with excessively high crowns. This forces the vehicles to the centre, there to produce more ruts and hollows by tracking, and creates such steep shoulders that it becomes not only difficult, but even dangerous, for wagons to turn out on them.

The transverse grade depends upon the longitudinal slope of the road and the material of which the road is constructed. Consequently, as earth has a somewhat high friction factor compared with that of other surfacings, and is easily cut up, it will require a much greater crown for a dirt road than one of a smoother and harder nature.

For purposes of drainage absolutely flat roads, *i.e.*, longitudinally, are to be discouraged, though theoretically they are most desirable, as all surface drainage would then have to be accomplished by means of the crown alone. On the other hand, the longitudinal grade should never be so great as to allow the water

to flow in a torrent along the middle of the roadway and wash out gullies; or, if the grade is excessive, the transverse slope should be proportionally increased, within the limits mentioned, to counteract this tendency and cause the water to move diagonally across the road toward the gutters.

Where longitudinal grade exists it is customary to construct shoulders, called "thank you mams," water breaks, or

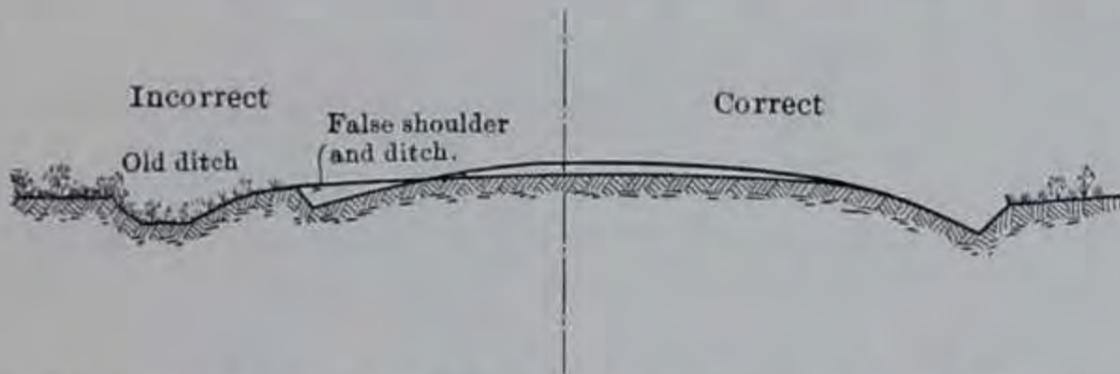

FIG. 12.—This road will be soft in spring season and will be only temporarily repaired by being worked in the shape shown on left side of drawing.

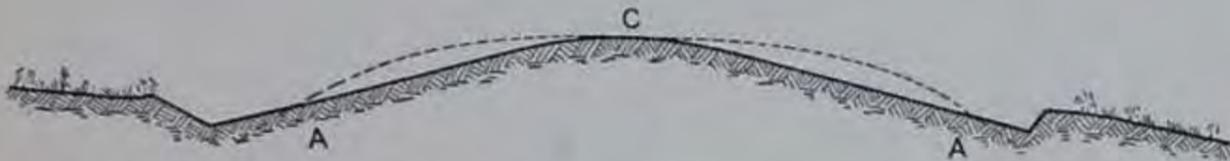

FIG. 13.—This road will rut at all points where teams pass each other or whenever they get out near the points A, A. C is correct height above ditch. A, A are too low to hold; dotted line shows proper shape.

breakers, at intervals along the road, to divert any water flowing down the centre to the ditches at the sides. These breakers are usually in the form of a shoulder of earth, or stone or logs covered with earth, set diagonally across the road, or else shaped like an obtuse angle with the apex in the centre pointing up-hill. Though necessary, to a degree, they increase the grade and therefore the tractive force, and on this account are objectionable; but it is also true that on steep inclines they afford a resting-place for horses in the ascent. Where they join the side ditches it should not be at too abrupt an angle, as they then tend to produce scouring of the gutter banks, but they must be made to approach them somewhat gradually.

In depressions also, surface catch waters are necessary to carry to the side ditches that which may have flowed down the centre of the road to the low spot. These differ from the others in that they are shallow trenches (to prevent jolting), crossing the road at right angles to its axis, and having the bottom paved with gravel, cobble, or field stone.

When a road exists on a side hill it is sometimes suggested that instead of the centre being crowned, the surface be made to slope toward the inner bank, so that all the water may flow in the ditch there, instead of being allowed to run over the face of the embankment. This is questionable practice, except on sharp curves, as more water is on the road, and for a longer period than when the slope is from the centre toward the sides. To protect such side-hill roads from the drainage from above, auxiliary ditches should be placed higher up the hill to intercept water flowing toward them.

As is easily recognized, unless a dirt road receive constant attention to preserve the form of the transverse section, the drainage must depend upon the longitudinal grade rather than upon the transverse slope, for as the material is soft the crown is soon destroyed by traffic. To correct this tendency, therefore, all depressions should be immediately filled with good fresh earth, while the surface should be constantly smoothed or rounded off to the required cross-section.

For this purpose a harrow may be advantageously used when the frost is coming out of the ground or when the roads are thick with mud, as it not only evens off the rough places, but cuts up the road sufficiently to make it dry out quickly and yet not impede the traffic. A railroad rail is used in a similar way in the spring to drag over the road for the purpose of cutting off high spots and filling in low ones. This should be from 14 to 16 ft. long and so arranged as to lie diagonally across the roadway when being hauled by a team. The edge acts as the cutter.

A light scraper, formed of a piece of 6 ins. by 12 ins. timber,

6 or 7 ft. long, and faced with steel may be quite effectively used in the same way.

THE ROAD DRAG, forms of which are shown in the cuts, gives most excellent results also and man miles of dirt road

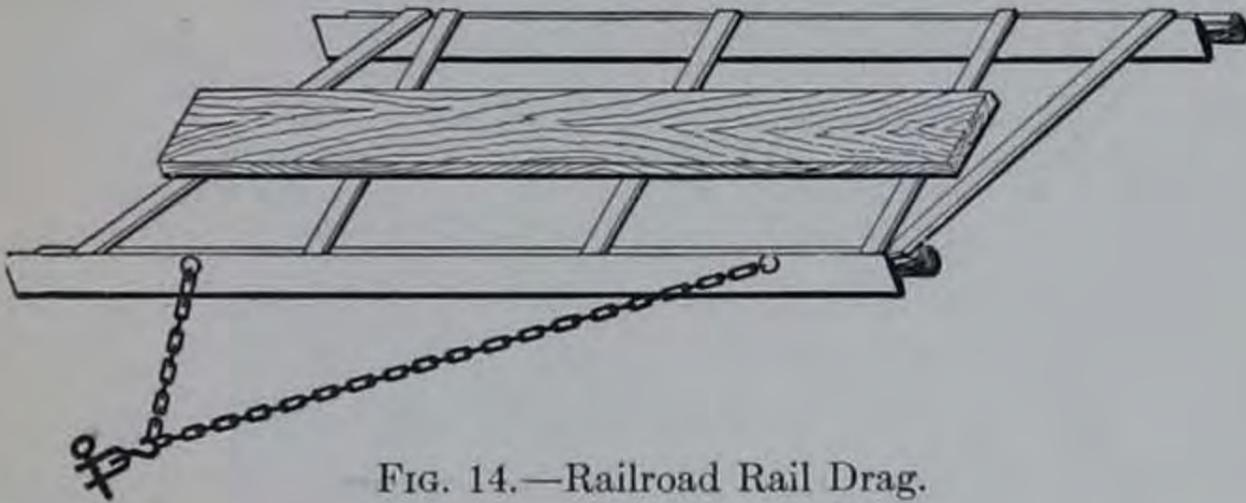

FIG. 14.—Railroad Rail Drag.

may be kept in first-class repair by its systematic and intelligent use. "The objects to be attained by this method of road maintenance are to smooth the surface of the road when it is soft

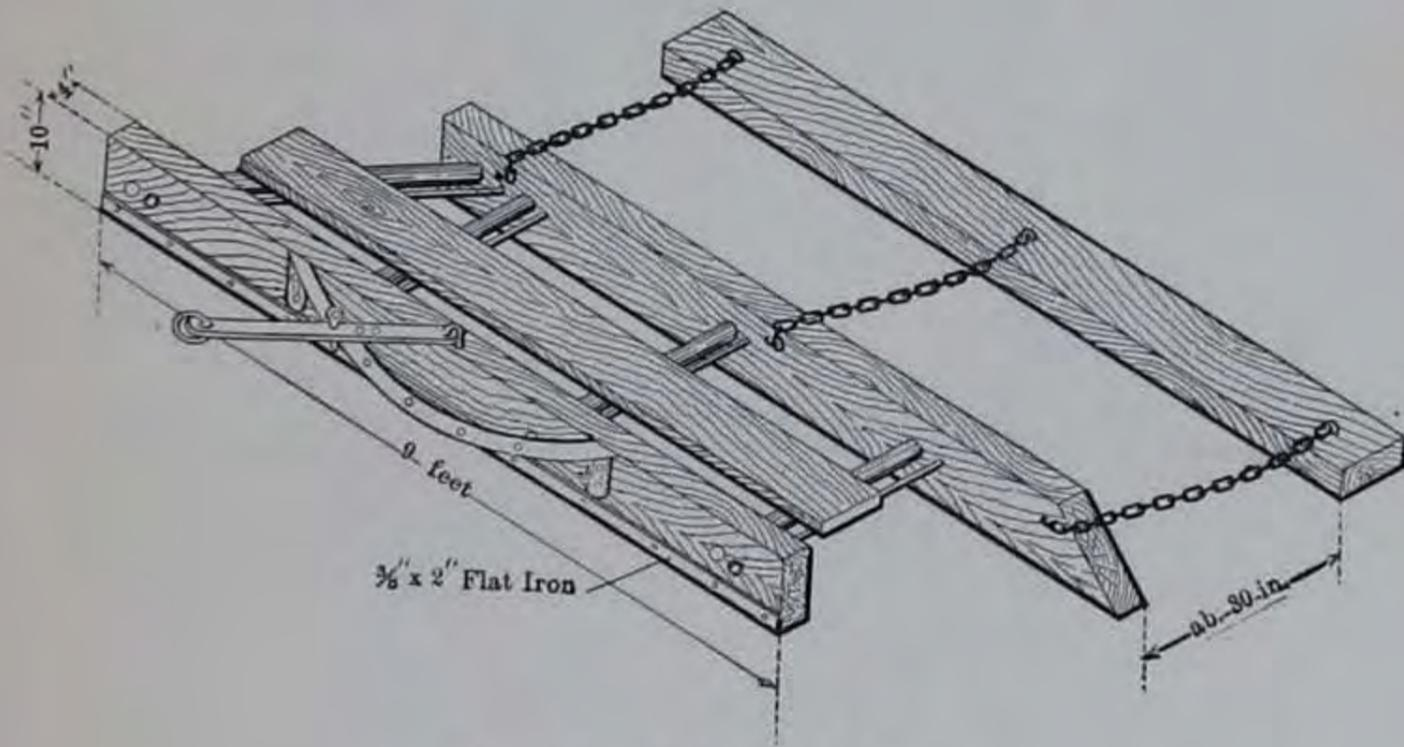

FIG. 15.—Oak Plank Drag.

and muddy, and at the same time to move a small amount of moist earth to the centre, thereby maintaining the crown of the road. The drag is not the implement to use to move large quan-

tities of earth, nor does the maintenance of an earth road require the use of such an implement."

Rolling, next to drainage, will keep a dirt road in better condition than anything else, though the expense connected with it may be large. A heavy road roller will maintain a hard even surface and preserve the cross-section intact, thus insuring good surface drainage and protecting the subgrade as well.

For this purpose one of 10 to 12 tons with a pressure of about 500 lbs. per lineal inch of roller wheels may be used to excellent advantage. Such rolling will discover the weak spots, which

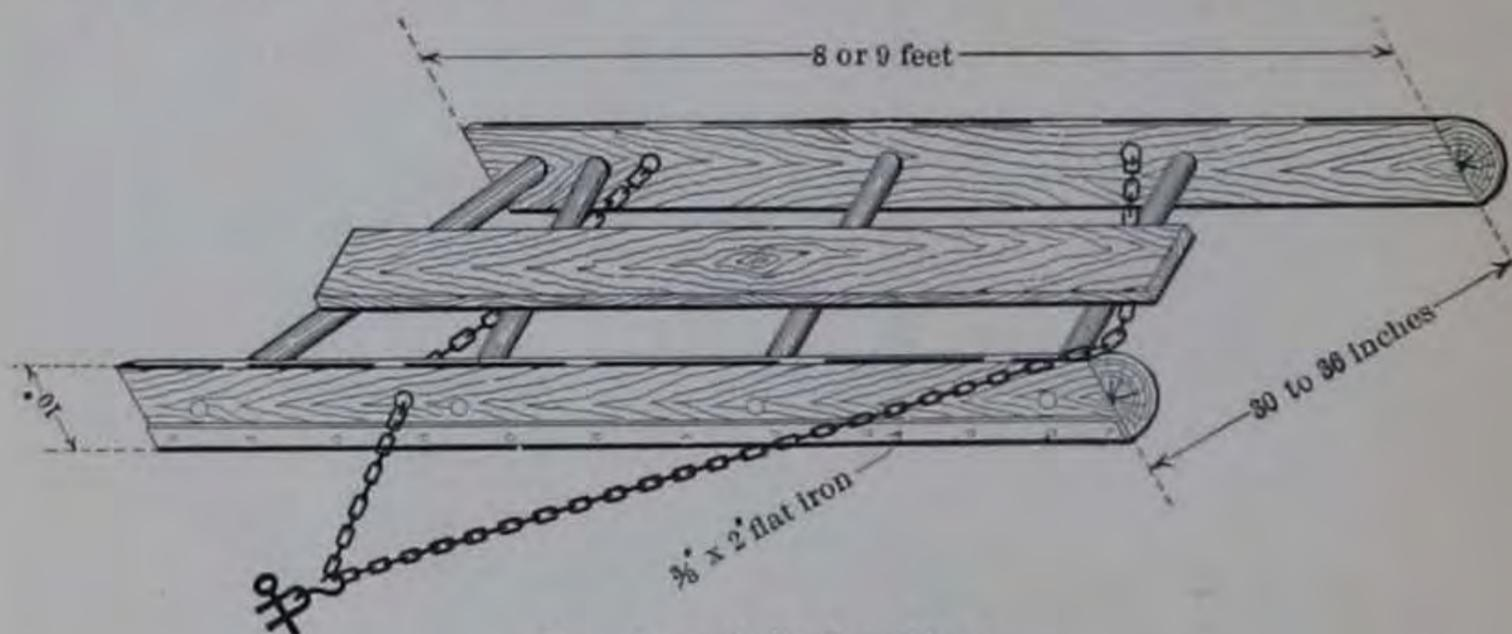

FIG. 16.—Split Log Drag.

should be immediately filled with new material that binds readily, and if employed in the fall as the roads freeze, will keep them in good condition nearly the whole of the winter. In the spring also, when the frost is coming out of the ground, it will be found that a road roller may render excellent service to keep the roads in a passable condition.

Subsurface Drainage means the draining of the soil, directly beneath the covering, of that water which may have gotten into it either by percolation from above or from the subsoil below. This is the best method of caring for a road, as it drains the soil of the ground water and keeps it continually dry, precluding mud and preventing frost action. A road built upon a wet and



FIG. 17.—Method of Constructing Drain in Clay or Other Wet Soil.

undrained base will be expensive to maintain if it is not altogether destroyed by the action of water and frost. If dirt roads satisfied the condition of having an impervious surface, no water could come from above, and the underdrains would simply perform the function of caring for the ground water, but as they do not, some provision should be made for this condition. Ground water is, of course, the very much more important factor, and particularly in excavation, where it tends to flow toward the road. In embankment, on the other hand, the water tends to flow away from the road.

It seldom happens that dirt roads need be continuously underdrained with tile or some other form of drain, for any distance, but it frequently does occur that at some particular point it is necessary to collect the water in the bed of the road, or to carry it from one side to the other by this means.

Under such circumstances the method adopted depends in a measure upon the nature of the soil. A sandy one is easily drained, as it does not readily hold water, the crown and side ditches being all that are required for the purpose, but with clayey material the contrary is the case, as it is very retentive of moisture.

Porous tile drains, made of burnt clay, seem to collect and dispose of the water most satisfactorily, as they neither become choked nor require much grade. Such tiles are made in various forms and sizes, but those of circular cross-section, five or more inches in diameter, are to be preferred.

The drains may be located in a number of ways along the road, as, for example, a single line beneath the centre of the road-bed; a single line under one of the side ditches; two lines, one beneath each of the side ditches; or by laying the drains herring-bone fashion along the middle of the road with the apexes pointing up-hill, fifteen to thirty feet centre to centre, and the branches falling away to the side ditches into which they discharge the ground water.

In any case they should be at a depth of two or three feet to keep the subgrade well drained and prevent the pressure of heavy loads from breaking them.

To prevent small animals from entering the drains and choking them up, the outlets should be protected with wire netting placed over the mouth, and to preclude the possibility of the water eroding the banks, the ends, projecting some distance beyond, should be set in some sort of masonry.

The method of laying the tile with stone directly above and the earth on this is shown in the cut. The ends of each length should be in close contact with the two adjoining ones. No collars are necessary, to prevent silt from entering at the joints.

The size of such drains depends on the estimated amount of water to be carried off, and the grade, but should never be smaller than 4 or 5 ins. A grade of 1 in 60, or 1 in. in 5 ft., will be found sufficient to care for the water, though as low as $\frac{1}{2}$ in. per 100 ft. has been used successfully in flat countries. Where the ground is exceptionally level, grade may be secured by placing the upper end of the pipe line at a less distance below the surface than the other end.

The following table shows the size of pipe required, with a given grade, to discharge a given quantity of water.

SIZES OF DRAIN-PIPE REQUIRED FOR CULVERTS IN PROPORTION TO CAPACITY AND FALL.

Inches.	3-Inch Fall per 100 Ft. Gallons per Minute.	6-Inch Fall per 100 Ft. Gallons per Minute.	9-Inch Fall per 100 Ft. Gallons per Minute.
6	129	183	224
8	265	375	460
9	355	503	617
10	463	655	803
12	730	1,083	1,273
15	1,282	1,818	2,224
18	2,022	2,860	3,508
24	4,152	5,871	7,202



FIG. 18.—Detail of Drain.

Where water is to be carried beneath the roadway from one side to the other, clay or tile drains may be used if the quantity is small, but where the amount is large a culvert may have to be built.

A culvert is an opening for the above purpose, constructed of dry or wet masonry, or concrete, with vertical sides and flat or arched roof.

They should be protected at the ends where they emerge from the embankment in the same manner as are drains, only to a greater degree, by wing walls and an apron of masonry to prevent erosion, and for this reason it is better to have a stone foundation than one of earth.

Side Ditches. For a satisfactory and cheap method of road drainage there is none better than that afforded by the side ditches, and most frequently this is the only effective one employed to any extent, or the only one found necessary. These ditches are placed on both sides of the roadway wherever possible, not only to carry off the water falling on the surface and draining into them, but also to intercept that which may flow from neighboring land toward the highway, and, furthermore, perform the function, when deep enough, of draining the subgrade and keeping it continually dry.

Where open ditches may not be conveniently used at the sides, others, as shown by the cuts, are employed to perform a similar function.

All ditches should be of such a cross-section that a scraper or road machine may be easily used in their formation and maintenance, as when so constructed they are easier and cheaper to keep in repair. The following figures show the sections of a shallow and of a deep side ditch where this condition obtains. The shallow ditch is, all things considered, much the more preferable, not only because, from the standpoint of cost of construction and maintenance and repair, it is cheaper, but it also affords an easy and safe place to turn out when teams are crowded

to the side; it should be remembered, on the other hand, however, that the deeper a ditch is the better the subgrade will be drained. Side ditches should be kept as free as possible from foreign matter, such as brush, sticks, stones, weeds, etc., since its presence prevents the speedy discharge of the water gathered there. This latter can only be secured by a grade sufficient to carry off the water and any suspended matter it may contain, yet not so great as to cause the washing away of the side banks.

It is needless to say that side ditches should never so far fail in their function as to permit water to stand in them for any length of time, for this simply keeps the subgrade soft and moist, and it should be rectified by either a change of grade or the cleaning out of the ditch and its outlet. The transporting power of water is quite considerable, velocities of thirty feet per minute being able to move fine clay, while double that velocity or sixty feet per minute will move gravel.

On steep grades it is well to have the ditches so far removed from the road that a strip of brush or small trees may be grown between them to afford protection to the side slope next the road, by the roots, and thus prevent the scouring action of the water with the ultimate destruction of the road. Much more frequently, however, the same effect is accomplished by sodding the side slopes or laying field stone in the gutters. Slopes of 1 in 150 to 1 in 125 give very satisfactory results for this sort of drainage, but often these values must necessarily be greatly exceeded because of the grade in the road itself. Where such is the case, the erosion in the ditch may then be quite considerable unless some provision as noted above is made to counteract it. The tendency under these circumstances will be for the water to cut away the material on the longitudinal section midway between the bottom and the top of the hill, with the result that the grade is greatly increased at a point where, if anything, it should be diminished, *i.e.*, at the top of the hill, for it is here that the horse is most fatigued, and where, if a change

is to be made at all, it should be toward diminishing the tractive force rather than increasing it so that the least effort will be required.

Crown. The transverse contour may be in the form of a gentle curve with the highest point at the centre, or of two planes intersecting at the middle of the road. Where the curve is used, either circular or parabolic may be taken, but in dirt roads this makes little difference as such small discrepancies are impossible to preserve in so soft a material.

The following figures 19, 20 and 21, show the variation in crown for different materials.

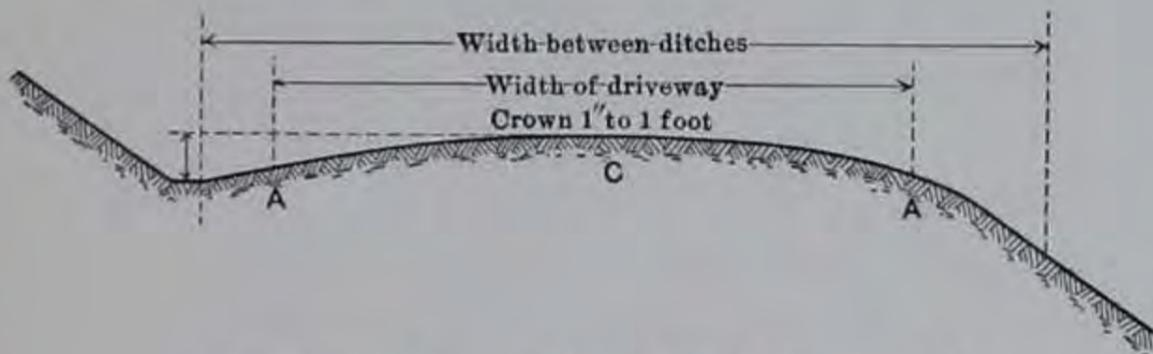

FIG. 19.—Gravelly Loam or Ordinary Soil.

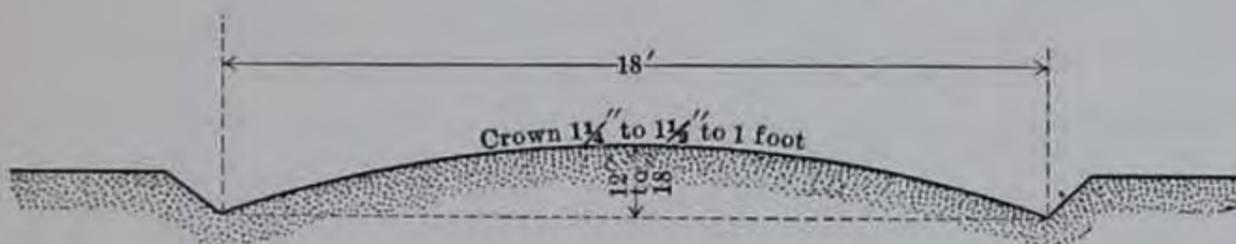

FIG. 20.—Sandy Loam.

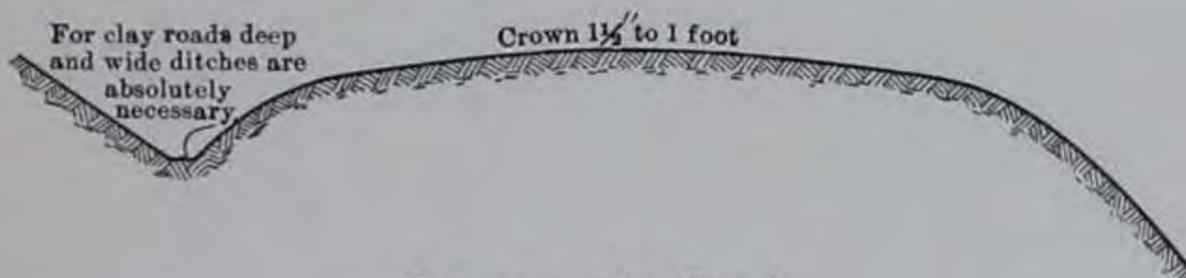

FIG. 21.—Clay Road.

With smooth, hard pavements, where the friction is small and which do not yield to the action of traffic, the inclination may be made correspondingly small; but in dirt roads, where both of these conditions are quickly destroyed, the maximum must be

applied; crown, however, should be given in moderation, for too much of it concentrates the traffic in the centre, causing ruts which hold water, and hence the surface is not so dry as with a flatter contour.

For satisfactory surface drainage and yet not too excessive crown, a rise of $\frac{1}{40}$, the half width of wheelway, is recommended for dirt roads. Frequently the following rule is given for crowning country roads—at $\frac{1}{4}$ the distance from the centre give $\frac{7}{8}$ of the total rise, and at $\frac{1}{2}$ the distance $\frac{5}{8}$ of the total rise.

Width. The right of way, which means the space between fence lines, varies in the United States from 40 to 100 feet. In dirt roads it is always well to appropriate as much of this as is

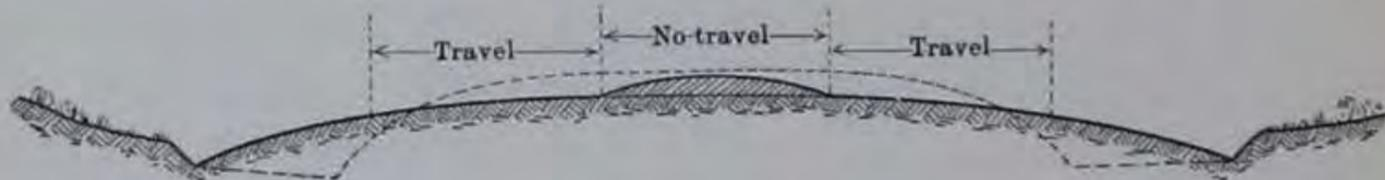

FIG. 22.—Too Wide for the Traffic. Dotted Line Shows Proper Shape.

consistent for the wheelway, not only to prevent the effect of traffic following the same line, but to derive also the advantage of the effects of sun and wind which, next to drainage, are the most important factors in keeping the roadway in a dry condition. Particularly in wet weather are wide roads advantageous, as they permit a choice of route. On the other hand, while every road should be wide enough to accommodate the traffic it is intended to carry, it should be noted that any increase in the width means an increase in the cost of construction and in the item of maintenance and repair.

Very frequently in small towns where dirt roads are extensively used the width of wheelway, forty to forty-five feet, is far greater than the demands of the traffic require or is desirable from an economical standpoint. A much better arrangement is a narrower wheelway with the rest of the space devoted to grass plots, whereby the cost of repairs is reduced and the appearance of the street improved.

On purely rural highways, where the traffic is light, the width of travelled way will be about eight feet as a minimum, but these are always provided with shoulders that make it possible for the teams to turn out in passing each other.

Side Slopes. The slope of the banks to both the ditches and the sides of the roadbed, either in excavation or in embankment, depends primarily upon the nature of the material. Where this is firm and will stand, as small a slope as that represented by a vertical rise of 4 ft. in 1 ft. horizontal may be sufficient; but where it is soft or yielding, a slope of 1 ft. vertical to 4 ft. horizontal may be required. In the latter case the longitudinal grade also will have to be small to prevent the transportation of material, unless some method of protecting the ditches is adopted.

The most common slope is 1 on $1\frac{1}{2}$, or a rise of 1 ft. in a distance of $1\frac{1}{2}$ ft., since at that angle most earth embankment will stand. The following values are those most generally used with other materials.

	H.	V.
Loose earth, loam, and gravel	$1\frac{1}{2}$	to 1
Sand.....	2	to 1
Soft greasy clay.....	3	to 1
Rock.....	$\frac{1}{4}$	to 1

It is always better to have the side slopes as gentle as possible, as the broader the ditch the less likelihood there is of the material slipping when water-soaked, in which condition it is least stable.

The term earthwork is applied to all operations of embankment or excavation, which include rock or earth, in the preparation of the roadbed. The excavation should always be in such amount, within economic limits of haul, as to equal the embankment, for, where this does not obtain, material in the one case must be borrowed from off the right of way to satisfy the "fill," while in the other it becomes necessary to waste the excess of "cut." In the former case the material is taken from a borrow pit, while in the latter the place where it is wasted is called a spoil bank. In balancing "cut" and "fill" it is very necessary to

remember that different materials occupy greater or less space after excavation than before; thus the amount of shrinkage after displacement is shown by the figures below.

Gravel.....	8 per cent
Gravel and sand.....	9 per cent
Clay and clay earths.....	10 per cent
Loam and light sandy earths.....	12 per cent
Loose vegetable soil.....	15 per cent
Puddled clay.....	25 per cent

On the other hand, rock increases in bulk by about fifty per cent. As an example, and to show the importance of considering this change, we may quote from the Massachusetts Highway Commission's Report. Owing to the depth of fill in an embankment and the character of the ground, it was deemed inadvisable to place the surfacing of broken stone, curbing, paved gutters, etc., until a year had elapsed, "to give the embankment time to settle, thus saving the loss of costly material and the expense of repairs."

Maintenance and Repair. A typical country road is usually maintained and kept in repair by the aid of labor which is ignorant of the fundamental principles underlying such work, or careless of the results. Furthermore, the undertaking is indulged in perhaps once or twice a year, and the havoc created then is supposed to keep the road in good condition the rest of the time. This method is absolutely at variance with the needs, for a dirt road is one that is readily broken up, and it is only by constant and careful attention that it may be preserved in a highly satisfactory state. Under all circumstances, for good results, the system of continuous repairs, as adopted by one of the New England States, should be employed. This approaches more or less closely that employed in France, where a laborer is put in charge of a piece of road adjacent to his dwelling, and for which he is entirely responsible. Applied to dirt roads, it would mean the daily or periodic inspection of the section in question, the removal of

all stones, etc., from the highway, the filling up of ruts, depressions, and holes, the careful attention to the surface, crown, etc., the removal of brush, weeds, sod, sticks, and stones from side ditches, the cleaning out of the same, and of all drains or culverts to permit the free flow of water, together with the removal of snow in winter, and perhaps the application of oil in summer to prevent dust.

One of the worst features in present-day practice of road maintenance is that through ignorance, instead of removing a thin surface layer of material that is valueless as a road metal, having lost all its binding properties, there is added to this more of the same character from the side ditches. The consequence is that this is soon reconverted into dust or mud and quickly deposited again in the side ditches from which it came, with the loss of the crown and the filling up of the ditch as the resultant twofold disadvantage. Any material that is lacking in binding power should be removed from the roadway to such a distance that there is no possibility of its getting back there again.

CHAPTER III

GRAVEL ROADS

GRAVEL roads seem to occupy an intermediate place between those of earth and broken stone, in the tractive force required, character of surfacing, and cost of construction.

On a well-made gravel road a horse is able to pull just twice the load he is capable of hauling on a dirt road, while this is only about one-half of what may be drawn on a macadam pavement. Gravel well applied makes a surface far superior to dirt, yet not possessing the wearing qualities of broken stone, and for this reason such roads are most frequently built under conditions where a covering other than earth is required, where the loads and traffic are light, and where the cost of broken stone is prohibitive. That is to say, gravel roads are best suited to country highways and park drives.

When stone roads are either impossible or impracticable, either because of the lack of suitable material in the vicinity, the excessive cost of the stone, or because of some other reason, gravel, if properly laid, will make a very superior substitute.

The gravel selected for road-building purposes will generally be that most conveniently located, thereby introducing the possibility of great variety, for with long hauls, *i.e.*, in excess of a mile and one-half, the item of transportation so increases the cost of construction as to make broken stone desirable.

Gravel consists of an aggregation of small stones, more or less worn and rounded by glacial or water action, and varying in size from that of a pea to pebbles two or more inches in diameter, and usually associated with some other and finer material that acts as a binder to hold the stones together. To be a serviceable and

satisfactory road metal, it should possess the following characteristics.

The pebbles themselves must be hard to resist the abrasive action of horses' hoofs and wagon wheels, and tough to withstand the blows of the horses' feet. The tougher and harder the stones, therefore, the longer will they resist this action. Besides possessing these qualities, however, the pebbles should be sharp and angular, since with sides worn smooth they freely move one upon the other and thus lack the characteristic mechanical bond possessed by broken stone.

Between pebbles and binder there should be such a relation that all the voids in the stones are completely filled, and in a manner to give the maximum cementing effect. If this disposition of material or ratio is exceeded, the binder must necessarily take some of the wear, a function which it is not supposed to perform and to which it is absolutely unsuited, while if not maintained, the bond will be weak and fail to hold the stones together.

Finally, the binder itself must possess to a marked degree the property of cementing the stones together, as otherwise the smooth pebbles move under traffic, similar to a mass of loose stone, and there is little stability in the pavement.

The binder may consist of loam, clay, iron oxide, silica, limestone, or one of a number of other materials, but that most generally found mixed with the stone is clay. Where the climatic conditions are favorable, this forms a very satisfactory bond, but with excessive rains or continued dry spells the cementing properties are quickly lost. In hot, dry weather the lack of moisture and the heat cause the clay to crack, leaving the pebbles as so many loose stones on the surface, while in wet weather the rain turns the clay to mud in which the stones soon disappear under the pressure of the wheels.

“Probably the best loam binder is one in which the clayey cement is very tenacious, and in such quantity that the gravel

will stick to the shovel enough to bother the workmen in handling it." If such a gravel possesses from three to ten per cent of chert* as well, the binding power will be further augmented, as the latter is easily crushed and possesses superior cementing qualities.

The mechanical bond spoken of above as existing in material composed of angular fragments, is an important factor in the consolidation of either gravel or broken-stone roads, the reason being that the irregularities and corners adjust themselves to each other in such a manner as to become wedged or locked together. For a somewhat similar result, in using gravel, the size should vary between about $\frac{1}{2}$ in. and 3 ins. so that the smaller particles may fit into the interstices formed by the larger. Material smaller than $\frac{1}{2}$ in. is too easily crushed in the pavement to be of much service, and larger than 3 ins. tends to make the road rough.

Gravel will be found to vary quite considerably, both in regard to the character of the stone and the quality and quantity of the binder present. River and seaside gravel are hardly ever so good as that from pits because the smoothness of the stones permits them to turn under pressure even when associated with a good binder. Pit or bank gravel generally contains more cementing material than other kinds, and the stones are less apt to be water-worn. The poorer kinds are, however, sometimes used as a foundation, or mixed with more binder to secure better results.

A good gravel may be determined by an inspection of it in the pit. If it stands with a vertical face, is compact, free from strata of sand, hard, needs a pick to dislodge it, and breaks in chunks, it will make an excellent road surfacing and require no further treatment.

That containing a ferruginous clay, together with sharp angular stones, is exceptionally good, as exposure to the air hardens the binder and produces the more complete consolidation of the material.

* "Chert is a silicious rock, a variety of quartz, somewhat like flint."

Usually the gravels occur in beds containing pebbles fairly uniform in size so that no screening is necessary, but where such condition does not obtain, a recourse must be had to it to remove the larger stones or the excess of earthy material. In the latter case, two screens are employed, one passing material under $2\frac{3}{4}$ ins. in diameter and the other of $\frac{3}{4}$ in. diameter. That which passes the smaller sieve may be appropriately used for side paths, while that retained on the larger screen may be used as a foundation or crushed to smaller sizes.

Screening, however, seems to possess a marked tendency to remove more of the binder than is desirable, and should be resorted to only when absolutely necessary.

In the state-aid roads of Massachusetts where screening has been employed, the material is sized into $\frac{1}{2}$ in., $1\frac{3}{4}$ in., and $2\frac{3}{4}$ in. stone. These are spread in courses, the larger on the bottom; each layer being separately sprinkled and rolled as in the construction of stone roads. Pebbles failing to pass the largest screen are sent to the crusher and again sized with the other gravel.

Drainage. The complete and satisfactory drainage of a gravel road is very essential and perhaps more important than with any other class as the material, particularly the binder, is so easily displaced by water flowing over the road.

The purpose of the covering should be to form a smooth, hard, impervious surface, and so distribute the load that the foundation may be able to resist the pressure without failure and consequent rutting of the surface.

If water is allowed to remain in the ruts and hollows, the subgrade soon becomes softened, the binder loses its properties, the pebbles become loosened, and the wheels cut through to the subgrade. The drier the subsoil the firmer it will be and the better able to perform its function as a foundation. In fact, gravel on a soft wet base is practically useless, as it is readily forced into the mud below. Because a gravel road is less pervious, and sheds more water than one of dirt, the side ditches or drains should be

both wide and deep: deep so that they may drain the subgrade of the roadbed well, and wide so that they may successfully care for the water diverted toward them. On steep grades the ditches are paved with cobble to prevent erosion, while on city streets the gutters next the curbs are similarly constructed to protect the sides from wagon wheels. In the latter case the stones serve the purpose of a shoulder for the gravel and prevent it from spreading.

The longitudinal grade, from the standpoint of drainage, should be as small as possible, as gullies are quickly formed by the water flowing along the axis of the road and the binder and pebbles are washed away. In such cases, the crown is made correspondingly high, to get the water off the roadway and into the side ditches as soon as possible.

Under normal conditions the crown need not be so great as that employed in earth roads, for the water encounters less resistance on the smooth surface of the gravel and reaches the ditches with a much smaller grade. A crown of $\frac{1}{4}$ to $\frac{3}{4}$ in. per foot of width or a rise at centre of $\frac{1}{50}$ the half width of wheelway is quite satisfactory.

The crown, however, depends very largely on the traffic, grade, and method of repairs, and for each set of conditions should be modified to suit. For example, on highways where the traffic is excessive the crown is proportionally increased; first, because the greater the haulage the greater the amount of wear to the surface between periods of repair, and second, because ruts are more quickly made, retarding the flow of water which the crown must counteract.

Construction. There are two general methods of building gravel roads, known as Surface Construction, and Trench Construction.

SURFACE CONSTRUCTION is perhaps very much less satisfactory than the other because it exercises less care in the work. In its crudest form it simply means that upon the old and un-

prepared roadbed a certain amount of gravel is dumped or strewn with the hope that traffic will consolidate it into an impervious pavement. This may be the case with very exceptional conditions, *i.e.*, where the roadbed is dry, hard, and well drained, and where the gravel is of such character that it binds well and quickly under the action of wagon wheels and horses' hoofs; but it is generally bad practice and only a makeshift at best. It is true that the Massachusetts Highway Commission has found gravel roads thus built in excellent repair after twelve years of service, but these are isolated cases and where the factors have been carefully studied and found extremely favorable.

On the contrary, the more care and preparation the original dirt road receives for the reception of the gravel covering, the better will it serve its purpose and the less it will cost to maintain and repair. The roadway, therefore, should first be properly graded, crowned, and rolled to secure a firm, even surface, and the drainage carefully inspected, both as to the side ditches and subsurface drains, to see that the water is capable of being carried away as soon as possible. With such assurance, the gravel may be placed upon this as a foundation, being distributed over the surface in successive layers three to six inches deep. Each course is liberally sprinkled with water to insure speedy consolidation, and a road roller of ten tons is then used to perfect this. Should depressions develop during the rolling, more material must be spread upon such places, until, after a continuance of the process, the entire surface has been brought to the proper grade. If the consolidation is satisfactory, a second layer may be applied and treated in the same manner, the operation being repeated until the pavement is of the required thickness.

In some cases the traffic alone is allowed to perform the function of consolidating each course of material, but it is not nearly so satisfactory, as it introduces foreign matter between the different layers, thus precluding as firm a bond, and requires very much more time to accomplish. Unless the subgrade is

drained properly and prepared to receive the gravel, frost and rain easily affect the foundation so that a considerable number of months may elapse before the road is in any other than a very unsatisfactory condition.

The most critical period in the life of a gravel road is when traffic is first admitted to it, as then ruts are quickly and easily formed to remain as permanent defects unless rectified at once.

Massachusetts has adopted the following method in the construction of gravel roads. The bed is examined for low, wet, and weak spots, and carefully prepared as a foundation, by removing objectionable material, laying drains, digging ditches, and thorough rolling, to receive the gravel to be placed upon it. This consists of a bottom course of screenings of the required depth, with a surfacing coat of one-inch gravel mixed with considerable binder above it. The whole road is then rolled until it becomes hard and smooth, being well watered during the operation to assist consolidation.

TRENCH CONSTRUCTION varies but little from the other form except in the fact that a trench is excavated of the required width and from eight to ten inches deep, for the purpose of holding the gravel in place by means of the shoulders at the sides. The bottom of the trench or foundation for the gravel, prepared as in the previous case, may be flat or correspond in section to that of the surface of the road, the latter requiring less material.

The advantage of this over the other method is in the fact that the shoulders hold the gravel in place and prevent its thinning out at the centre by working over to the sides. The material is applied as in surface construction.

In either form of construction, it is better that the gravel vary uniformly between $\frac{1}{2}$ in. and 3 ins. so that the voids between the larger pebbles may be filled by the smaller ones. If this is not the case, screening should be resorted to, so that material over $2\frac{1}{2}$ or 3 ins. and less than $\frac{1}{2}$ in. may be rejected. The larger size may be used as a foundation upon which the

other is placed, and when so used should be rolled and consolidated to a depth of about 4 ins., before the smaller size is applied. This is put in layers, each being thoroughly sprinkled and rolled, while the top layer is mixed with an excess of binder.

Experience in Massachusetts has shown that where the gravel is screened excellent results are obtained, and that while the roads wear more quickly than macadam, due to ravelling, this is not serious. Such roads are more easily maintained than others.

GRAVEL ON EARTH ROAD. Frequently the application of a three- or four-inch layer of gravel to an earth road will greatly improve the surface. It should be remembered, however, that this will not be the case if the soil is wet, and if such conditions prevail the subsoil must in some way be underdrained. If the material is clay instead of loam, gravel to a depth of six inches will be necessary. Under any circumstances the gravel should be thick enough to prevent the traffic from forcing it into the clay below and at the same time prevent the surface water from percolating to the soil beneath, saturating it and weakening it.

It is needless to dump the gravel into ruts, mud-holes, etc., and look for traffic to consolidate this and produce a superior highway. Drainage must be attended to first, last, and all the time, or the results will be anything but satisfactory.

Maintenance and Repairs. MAINTENANCE. "1. After a newly constructed gravel road has been thrown open to traffic, it should be carefully watched in order that any defects may be remedied at once. Shallow ruts and depressions should be repaired without delay, or serious damage will be the result. In repairing a new road the gravel on the sides of the depression may be raked back in place; but after a time it will become necessary to fill the depressions with new material. In the latter case the old hardened surface should be slightly loosened with rakes in order to get a bond between the old and the new material. The gravel used should be smaller in size and should also contain more binding material than that used in the construction. This

material should be stored in piles along the road-side, containing fifteen to twenty cubic yards each. Smaller piles are soon scattered and wasted. 2. Loose stones should be raked off the road surface as soon as they appear. They are uncomfortable for the travelling public, spoil the beauty of the road, and help to destroy it. 3. Care should be taken to fill all the hollows and depressions in the centre, made by the horses' feet, in order to avoid having water remain on the surface. If the gravel becomes saturated and soft, it wears more rapidly and will soon rut. It is important that the crown of the road should be preserved and that water should not be allowed to run down the centre, but should have an unobstructed flow to the side ditches. In cases where the centre has been worn hollow the crown should be restored by adding the proper amount of suitable material. This work should be done when the road is wet and soft and the gravel will easily compact and bind together." 4. The ditches and culverts should be kept free from obstructions at all times, to secure an easy flow of water.

Maintenance of this nature may best be accomplished by careful and constant supervision, aided by the use of an ordinary garden rake, to remove the larger pebbles and to smooth the surface. After the road has become compacted such constant attention will not be so necessary.

REPAIRS differ from maintenance in that they are more extensive in character, the surface having to be practically rebuilt. This should be accomplished by the application of one or more layers of gravel, two inches thick, as a greater thickness does not pack or bind so quickly.

One of the chief advantages of gravel roads is that they are so easily repaired. Unlike dirt roads, gravel highways may be repaired in the fall without either hindrance to traffic or injury to the road. The gravel, except in very extensive and complete repairs, should be applied in patches rather than in great stretches, and then in small quantities as it will much more readily combine

with the old surface, and at the same time offer less obstruction to traffic. This application may be continued until the entire road has been covered.

The material used for repairs should not be that which is taken from paring down the shoulders or that which has been washed to the sides, but rather new material kept for that particular purpose. Repairs with loam, sand, etc., are bad because such material only serves to put the surface in a sandy or miry condition. The shoulders should always be kept true to the section and the gutters kept open.

For gravel roads, perhaps more than any other, the method of continuous repairs is the most advisable.

GRAVEL VS. MACADAM. "No just comparison can be made between gravel roads and macadam, as at no time is a gravel road in a condition to give first-class results. Suppose a 2-horse load of gravel delivered on the road costs from \$1 to \$1.25 a load of about $1\frac{1}{4}$ ins. cu. yds. A road made about 6 in depth at this price should cost from 20 to 25 cents per sq. yd. More or less new gravel has to be put on each year, and it is safe to say that at the end of each 5 years an amount equal to the original depth has been used. This makes the total cost about 4 to 5 cents per sq. yd., annually. If a macadam road be built of broken stone costing \$2.15 per cu. yd. of metal on the road including rolling, the cost per sq. yd. would be about 47 cents. A road built in such a manner would easily withstand the traffic common to localities removed from the business centres for 20 years, with slight repairs during that time. This would make the annual cost per sq. yd. about $2\frac{1}{3}$ cents. By these estimates the macadam road in a term of 20 years will cost from about $1\frac{2}{3}$ cents to $2\frac{2}{3}$ cents per sq. yd. less annually than the gravel road."

The following specifications for gravel roads, taken from the Annual Report of the Commissioner of Public Roads for the State of New Jersey, and indicating the practice existing in that State, are well worthy of consideration.

STANDARD STATE AID SPECIFICATIONS FOR GRAVEL ROADS

FOR A GRAVEL ROAD IN.....COUNTY, NEW
 JERSEY KNOWN AS.....
 BEGINNING AT..... AND
 EXTENDING TO.....
 A DISTANCE OF.....FEET, OR.....MILES.
 GRAVEL.....FEET WIDE.....INCHES DEEP.
 SHOULDERS.....FEET WIDE. TOTAL WIDTH OF ROAD....FEET.

WORK TO BE PERFORMED

1. The work to be performed will consist in furnishing all material, tools, machinery, and labor necessary for the efficient and proper grading of roadway, side ditches, and side banks, laying, spreading, and rolling of road material, and leaving the roadway complete in every manner ready for immediate use.

PLANS AND DRAWINGS

2. The plan, profile, and cross-sections on file in the office of the State Commissioner of Public Roads and at the office of.....County Engineer,.....New Jersey, show general location, profile, details, and dimensions. The work will be constructed in all respects according to the above-mentioned plan, profile, and cross-sections, which form part of these specifications.

3. Any variation of location, profile, size, and dimensions from that shown on the plan, as may be required by the exigencies of construction, will, in all cases, be determined by the engineer, but the contractor shall not, on any pretence, save that of the written order of the contracting parties and the State Commissioner of Public Roads, deviate from the intent of the plan or specifications.

4. On all drawings figured dimensions are to govern in cases of discrepancy between scale and figures.

GRADING

5. Under this head will be included all excavations and embankments required for the formation of the highway, cutting all ditches or drains about or contiguous to the road, removing all fences, walls, buildings, trees, poles, or other encumbrances, the excavation and embankment necessary for reconstructing cross or branch roads or entrances to dwellings in cases where they are destroyed or interfered with in the formation of the roadway, and all other excavations and embankments connected with or incidental to the construction of the said road.

EXCAVATION

6. The roadway to the width of feet as shown on plan must be excavated or built to the same curvature as that of the surface of the road when finished; the grade, from centre to sides, must be as shown on plans.

7. The earth taken from any cut or ditch shall be deposited where the engineer may direct, either within or without the lines of the road, but no earth shall be removed from the line of the road without the order of the engineer.

EMBANKMENT

8. Material taken from the excavations, except when otherwise directed by the engineer, shall be deposited in the embankments, either on the roadway or sidewalks.

9. When there is not sufficient material in the excavations of the road to form the embankments, the deficiency must be supplied by the contractor from without the road. The character of said material and place of excavation must be approved by the engineer.

10. The embankments must be formed in layers of such depth,

generally twelve (12) inches, and the material deposited and distributed in such manner as the engineer may direct, the required allowance for settling being added. Each layer must be carried across the entire width of the embankment and completed before commencing another, and this method shall be followed with each succeeding layer until the established grade is reached.

SLOPES

11. Slopes in both embankment and excavation shall be one and one-half ($1\frac{1}{2}$) horizontal to one (1) vertical, when the width of the road will permit; if the road is too narrow to allow the full slope within its side lines, the engineer shall not calculate the quantities, either in embankment or excavation, beyond said side lines, unless the required ground shall be first dedicated to the public in writing by the owner or owners thereof.

ROADWAY

Subfoundations

12. When the excavations and embankments have been brought to a proper depth below the intended surface of the roadway, the cross-section conforming in every respect to the cross-section of the road when finished, the same shall, if ordered by the engineer, be rolled until approved by him. If any depressions form under such rolling, owing to improper material or vegetable matter, the same shall be removed and good earth substituted, and the whole re-rolled until thoroughly solid and to above-mentioned grade.

SHOULDERING

13. A shoulder of firm earth or gravel is to be left or made on each side of the gravel bed, extending at the same grade and curvature of road to side ditches or gutters. This shoulder is to be rolled according to the directions of the engineer.

UNDERDRAINS

14. Underdrains, if found necessary, shall be constructed by the contractor (at prices named in bids) of good inch tile, laid upon a board of not less than one (1) inch in thickness and six (6) inches in width, whenever and wherever the engineer shall decide; top of tile or pipe must be at least inches deep, unless otherwise directed by the engineer; the joints of the tile or pipe must be covered with salt hay, or material equally as good, and trench filled with pervious earth.

15. When directed by the engineer a stone drain may be used in place of the tile drains. A trench one foot in width and one foot six inches in depth shall be excavated below the subgrade, said excavation to be filled with loose broken stone to a depth required by the engineer.

MATERIALS

16. The material to be used in surfacing the road is to be furnished by the contractor.

17. The Road Committee, in conjunction with the engineer and State Commissioner of Public Roads, will pass upon and approve all gravel to be used in surfacing the road. The contractor is to dig, cart, and place upon the road, in accordance with the specifications, the gravel selected and use no other. Should any objectionable material be used, he is to remove the same at his own expense.

18. The contractor must furnish to the engineer and State Commissioner of Public Roads samples of the kind of gravel to be used in the work before the opening of the bids.

19. The gravel is to be placed upon the road in such manner as shall be approved by the engineer, and be thoroughly rolled and solidified until it is consolidated, firm, and approved by the engineer. The gravel shall be of such thickness that when it is thoroughly compacted and approved, it shall be inches

deep in the centre and slope at a regular grade to inches in depth at a distance of feet on each side of the centre line.

20. Should any depressions appear these are to be carefully filled with gravel, so that the finished road will conform to the approved profile.

21. The contractor is to be paid by the cubic yard, as per depths above named, for the compacted gravel that he puts on the road, at the price named in the accepted bid, which shall include finishing the road and shaping the shoulders as above specified.

22. The contractor is to place sufficient gravel on the road to allow it to shrink thirty-three per cent in rolling and settling.

SIDEWALKS

23. The contractor will also be required, when the engineer so directs, to grub and remove from a strip of land feet on outside of curb-lines all material objectionable to the engineer, such as trees, stumps, roots, and brush, and refill the holes with earth, thereby completing the opening of the entire road to a width of feet, which shall be feet on each side of the centre line.

24. The grubbing and removing of such objectionable material that is ordered by the engineer shall be styled as "grubbing," and paid for by the acre at price named in accepted bid.

OPEN DITCHES

25. The contractor is to grade the shoulders and open all necessary side ditches (as per stakes furnished by the engineer) so that there will be no water allowed to stand by the side of the road or upon it, for which no extra payment will be allowed.

EXTRA DEEP

26. Should the engineer and State Commissioner of Public Roads so order, the contractor is to build in all respects, as al-

ready specified, the gravel bed to a greater depth or thickness than that already named. The contractor is to do the same at a price named per square yard for each extra inch in depth.

NO EXTRA PRICE

27. No allowance in measure of depth of pavement will be made on account of any material which may be driven into the roadbed by rolling. The pavement, when completed, must conform to the grade and cross-section, and be satisfactory to the engineer and State Commissioner of Public Roads, whose decision shall be final.

28. No extra work will be paid for unless the price has been agreed upon between the contracting parties, including the State Commissioner of Public Roads, and endorsed upon the agreement, witnessed by the engineer.

BROAD-TIRE WAGONS

29. All wagons and carts used during the construction for hauling stone, earth, or any other material must have tires not less than three and one-half ($3\frac{1}{2}$) inches in width.

BIDS

30. Bids will be received under these specifications for the road complete as follows:

(1) Price per cubic yard for earth excavation, without classification, as per plans and cross-sections throughout the length and width of the road.

(2) Price per acre for grubbing and removing objectionable material from sidewalks.

(3) Price per lineal foot for completed tile drain.

(4) Price per cubic yard for compacted gravel as specified.

(5) Price per square yard for each ordered inch in depth in excess of thickness named.

(6) Price (lump) for the whole road complete, according to the specifications and plans prepared by the engineer.

No bid will be received in which all the above items are not filled out.

ESTIMATE OF QUANTITIES

31. (1) Earth excavationcubic yards.
 (2) Grubbingacres.
 (3) The drainlineal feet.
 (4) Compacted gravelcubic yards.
 Total estimated cost of the road, \$

32. These quantities are the result of calculation, but are to be considered as approximate. The county will not be responsible for any excess in above quantities, should any occur. The contractor is expected to satisfy himself by a personal examination of the work contemplated, about the nature, character, and quantity of the labor and material required.

CHECK ACCOMPANYING BIDS

33. Bids shall be accompanied with a certified check, payable to the Director of the Board of Chosen Freeholders, for the sum of one thousand dollars (\$1,000), as a guaranty that if the contract shall be awarded to him he will, when required by said Board, execute an agreement in writing to perform the work according to the specifications, and upon failure by the contractor to enter into said agreement with the said Board of Chosen Freeholders, said certified check shall be forfeited and considered as liquidated damages.

LIABILITIES OF CONTRACTOR

34. He shall keep up sufficient guards by day and night to prevent accidents from travel, and will be liable for any damage which may arise from his neglect to do so, or from any omission on his part.

35. He is to commence and prosecute the work upon the road at such points as may be directed by the engineer, within

days from and after the signing of the contract, and shall continue work thereon until completion, except as herein provided.

36. He further agrees to complete the same on or before the
day of A.D.

37. Twenty dollars for each day that the work shall remain uncompleted, after the time allowed by contract, may be deducted, as liquidated damages, from any moneys due contractor, unless otherwise agreed upon by the Board of Chosen Freeholders after presentation of certificate of the engineer recommending the extension of the time limit of completion.

38. The contractor shall keep the finished roadway, earthwork, side ditches, and underdrains in repair for the period of one year from the date of its completion and acceptance, and, in addition thereto, for as much longer as for any period or periods during said year it shall be out of proper condition. If, during that time, the roadway or any part of the work shall, in the judgment of the engineer and the Board of Chosen Freeholders, require repairing, and they shall duly notify the contractor to make such repairs as required, and the contractor should refuse or neglect to do so to the satisfaction of the said engineer and Board of Chosen Freeholders, within five days from the date of service of notice, then the said engineer and Board of Chosen Freeholders shall have the right to have the work done properly by other parties and recover the cost for the same from the said contractor or his surety.

39. The contractor will be required to preserve all stakes and bench-marks made and established on the line of work until duly authorized by the engineer to remove the same.

40. The contractor shall not disturb the position of titlestones (the corners of properties adjacent to the road), but where they appear he will either lift or lower them, under the personal supervision of the engineer.

41. The contractor must also preserve the roadway on which he is working from needless obstruction, and where necessary

construct safe and commodious crossings, to be maintained in good order. He shall afford all proper and reasonable means for the accommodation of the public, and leave the roadway complete in every manner ready for immediate use.

42. All loss or damage arising from the nature of the work to be done, or from any unforeseen or unusual obstruction or difficulty, which may be encountered in the prosecution of said work, or from the action of the elements, shall be sustained by the contractor.

PROVISION FOR DRAINAGE

43. If it is necessary in the prosecution of the work to interrupt or obstruct the natural drainage of the surface, or the flow of artificial drains, the contractor shall provide for the same during the progress of the work in such a way that no damage shall result to either public or private interests. He shall be held liable for all damages which may result from any neglect to provide for either natural or artificial drainage, which he may have interrupted.

RIGHT TO BUILD BRIDGES, CULVERTS, ETC., AND SUSPENSION OF WORK

44. The right of the county to build bridges, culverts, lay pipes or other appurtenances in said road during the progress of the work is expressly reserved, as well as suspending the work, or any part thereof, during the construction of the same, for the purposes above stated, without further compensation to the contractor for such suspension than an extension of time for completing the work as much as it may have been delayed.

STOPPING WORK ON ACCOUNT OF WEATHER

45. The State Commissioner of Public Roads, engineer, or supervisor may stop any portion of the work if, in their judgment, the weather is such as to prevent the same being done properly.

No allowance of any kind will be made for such stoppage, except an extension of the time for the completion of the work as herein provided.

ABANDONMENT OF CONTRACT

46. If at any time the work under contract should be abandoned, or if at any time the engineer should judge and so certify in writing that said work, or any part thereof, is unnecessarily delayed, or that the contractor is wilfully violating any of the conditions or covenants of this contract, or is executing the same in bad faith, then, and in that case, the Board of Chosen Freeholders shall notify the said contractor to discontinue all work under this contract. It may employ other parties to complete the work in such manner as it may decide, and use such material as may be procured upon the line of aforesaid work, and, if necessary, to procure other material for its completion, and charge the expense of the said labor and material to the contractor, which expense shall be deducted from any moneys due him under contract. In case these expenses shall exceed the sum which would have been payable under contract, if the same had been completed by said contractor, he or his bondsmen shall pay the amount of the excess to the Board of Chosen Freeholders, on notice from the engineer.

ENGINEER

47. The engineer shall be selected or appointed by the Board of Chosen Freeholders and paid by it. He shall furnish all surveys, profiles, plans, specifications, and estimates of quantities of all kinds before specifications are signed, and in such a clear manner that lump bids can be made upon the work. He shall furnish all lines and grades required for the completion of the work. He shall furnish estimates for quantities of work done before partial payments can be made, the quantity of road laid being determined by surface measurements. Should any difference arise between the contracting parties as to the meaning

or intent of these specifications, his decisions on these matters are to be final and conclusive. The work is to be done according to his directions, and if any material of which he does not approve is brought upon the road it is to be removed at the expense of the contractor. If the contractor fails or neglects to do any part of the work as specified or as directed by the engineer, then, in that case, all other work shall be discontinued, on notice from the engineer to the contractor, or to the superintendent or foreman in charge of the work for the contractor, until such time as the work complained of has been done to the satisfaction of the engineer, and the contractor will not be entitled to or allowed any compensation or extension of time for such discontinuation or suspension of the work.

SUPERVISOR

48. Nothing in these specifications relating to the duties of the engineer shall be taken or construed in any manner to conflict with the duties of the supervisor, as specifically set forth in the act entitled "An act to provide for the permanent improvement of public roads in this state," approved March 27th, 1905, but they shall coöperate as far as practicable.

INCOMPETENT WORKMEN

49. The contractor shall employ competent men to do the work, and whenever the engineer and supervisor shall inform him, or his representative in charge, in writing, that any man on the work is unfitted for the place, or is working contrary to the provisions of the specifications or the instructions of the engineer and supervisor, he shall thereupon be discharged.

INSPECTION

50. All directions and determinations necessary to give due and full effect to any of the provisions of these specifications shall be given by the engineer and supervisor.

51. All material and workmanship of any kind shall be subject at all times to the inspection of the engineer and supervisor. Whenever unfaithful and imperfect work is discovered, it shall be immediately repaired or replaced by the contractor, after due notification from the engineer and supervisor.

SUBLETTING OF CONTRACT

52. The contractor shall not assign or sublet any portion of this contract without the consent of the Board of Chosen Freeholders and the State Commissioner of Public Roads.

PAYMENTS

53. monthly payments will be made by the Board of Chosen Freeholders to the contractor for work performed, upon presentation by him of the proper certificates of the engineer and supervisor, in a sum not to exceed eighty per cent of the amount then due, together with releases from all liens, if required. Fifteen per cent will be paid at the completion of the work and the acceptance of the same in writing by the Board of Chosen Freeholders and the State Commissioner of Public Roads. The remainder, or five per cent, will be retained by the Board of Chosen Freeholders for a period of one year as security for the faithful performance of Article 38.

BOND OF CONTRACTOR

54. The contractor will be required to execute, within thirty days of giving of contract, a bond in such sum and with such securities as shall be approved by the Board of Chosen Freeholders, conditioned for the faithful performance of the contract, to indemnify and save harmless the said Board of Chosen Freeholders from all suits or actions of any name or description brought against them on account of any act or omission of the contractor or his agents, and for the faithful performance of the contract by the contractor. Said bond shall be in a sum of not

less than the estimated cost of the road when completed. Any change made in said plans, specifications, agreements, or quantities without the consent of the bondsmen shall in no way vitiate said bond. The said contractor hereby further agrees that so much of the money due him, under and by virtue of this agreement, as shall be considered necessary by the Board of Chosen Freeholders, may be retained by it until all such suits or claims for damages aforesaid shall have been settled, and evidence to that effect furnished to the satisfaction of the said Board of Chosen Freeholders.

CONTRACTOR TO INSURE PAYMENT FOR LABOR, MATERIAL, ETC., ON
FINAL ESTIMATE

55. The contractor must also furnish said engineer with satisfactory evidence that all persons who did work, or furnish material for this contract, or who have sustained damage or injury by reason of any act, omission, or carelessness on his part or his agents in the prosecution of the work, have been duly paid or secured; he shall also give notice to said engineer within ten days after the completion of the work, and before final estimate is made, that any balance for such work or materials, or compensation for such damages due, has been fully paid or released.

56. The right is reserved to reject any or all bids, if deemed to the interest of the county or State.

.....
County Engineer.

Approved this day of, A.D. 190 , by resolution of the Board of Chosen Freeholders of the county of

.....
Director of Board of Chosen Freeholders.

.....
Clerk of Board of Chosen Freeholders.

OFFICE STATE COMMISSIONER OF PUBLIC ROADS, TRENTON,
N. J.

I have this day carefully read and examined the foregoing specifications, and the same are hereby approved.

Any departure from these specifications must have the written consent of the State Commissioner of Public Roads.

Given under my hand, this.....day of, A.D.....

.....
State Commissioner of Public Roads.

CHAPTER IV

BROKEN-STONE ROADS

DEFINITION. A broken-stone road is one in which the surfacing material, resting upon an earth or stone foundation, is composed of small fragments of crushed rock, and so consolidated by rolling or traffic as to form a compact mass, with a smooth and impervious surface.

KINDS. Such roads are divided into two general classes, Macadam and Telford, receiving their names from the English engineers who, about the middle of the eighteenth century, were instrumental in demonstrating their superior qualities. Both types agree in the use of fragments of broken stone, but differ materially in the foundation upon which it rests.

Macadam. As originally built, a macadam pavement consisted of a layer of broken stone $2\frac{1}{2}$ ins. in diameter, and 8 to 10 ins. deep, laid for the full width of the roadway. According to Macadam, "The stone was employed to form a secure, smooth, water-tight flooring, over which vehicles might pass with safety and expedition at all seasons of the year. The thickness was regulated only by the quality of the material necessary to form such a flooring, and not at all by any consideration as to its own independent power of bearing weight."

This rested upon the natural soil as a foundation, particular attention being given to the matter of drainage, to prevent water either remaining in the roadbed or flowing toward it.

No binder nor road roller was used to help cement the fragments together, but consolidation depended entirely upon the action of traffic.

The term "binder," it should here be stated, applies to any

fine material, about one-quarter inch in size or smaller, which is used on a stone road for the purpose of filling in the interstices between the fragments of stone and cementing or binding them together, so that the covering may be smooth, compact, and impervious to water.

A **Telford Pavement** differs materially from one of macadam, being constructed as follows: "Upon the level bed prepared for

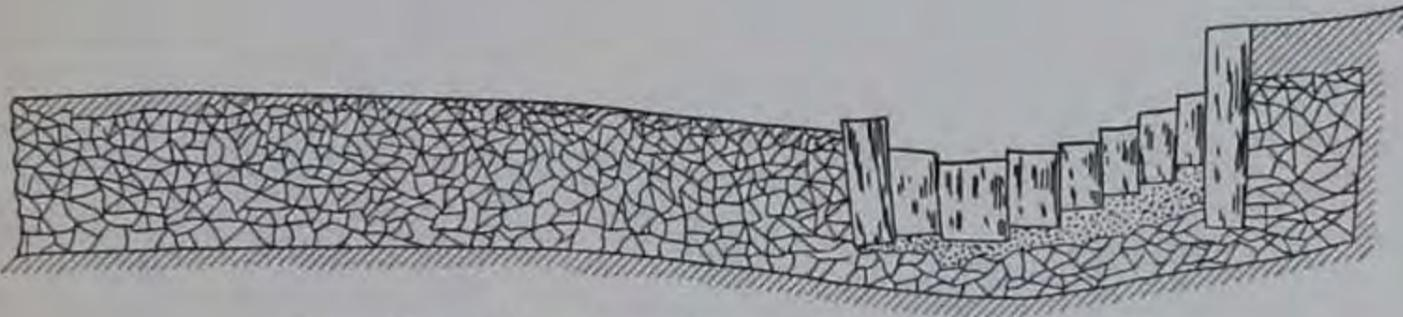

FIG. 23.—Macadam Pavement with Gutter.

the road materials, a bottom course or layer of stones is set, by hand, in the form of a close, firm pavement. The stones set in the middle of the road should be 7 ins. deep; at 9 ft. from the centre, 5 ins. deep; and at 15 ft. from the centre, 3 ins. deep. They should be set upon their broadest edges lengthwise across the road, and the breadth of the upper edge should not exceed 4 ins. in any case. All irregularities of the upper part of the

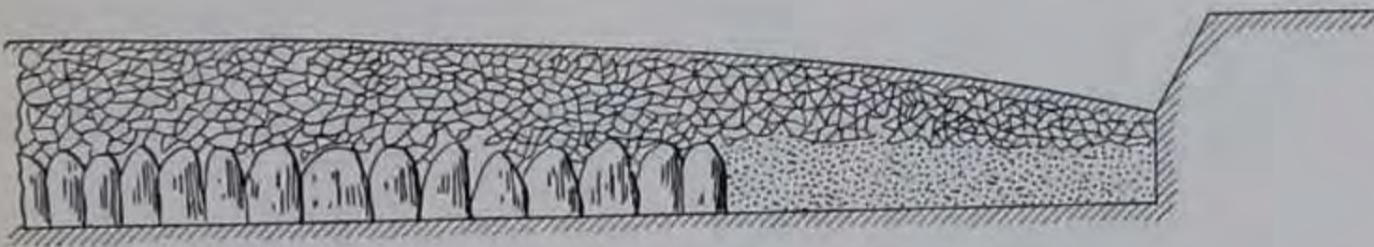

FIG. 24.—Telford Pavement.

pavement should be broken off by a hammer, and all interstices filled with stone chips firmly wedged, or packed by hand with a light hammer, so that when the whole pavement is finished there shall be a convexity of 4 ins. in the breadth of 15 ft. from the centre.

"The middle 18 ft. of the pavement should be coated with

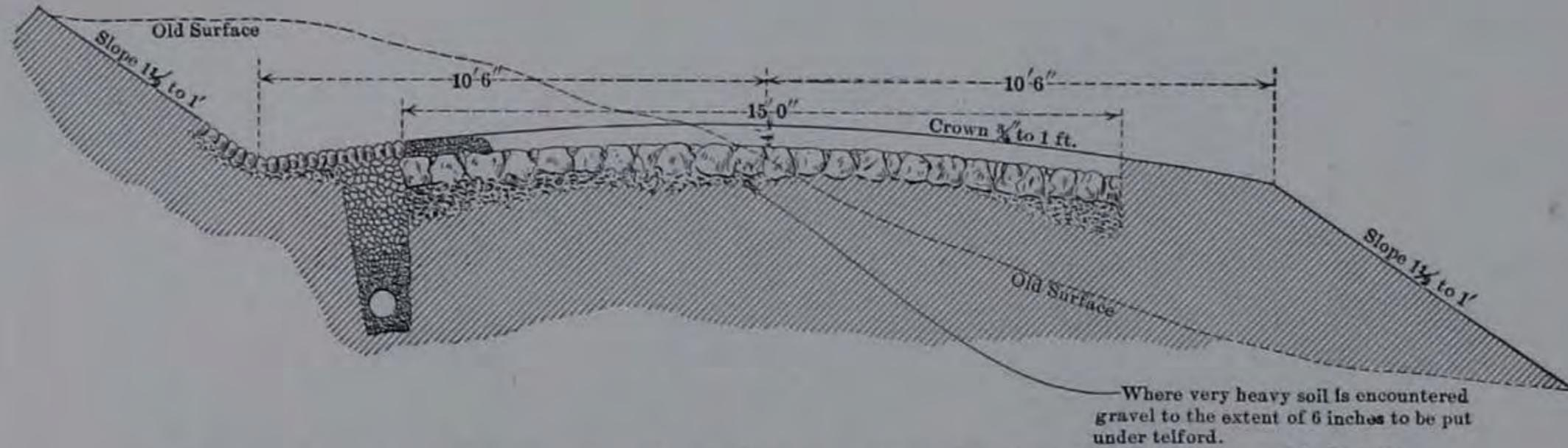

FIG. 25.—Standard Cross-Section Mass. Highways Showing Telford Pavement with Drain and Gutter at the Side.

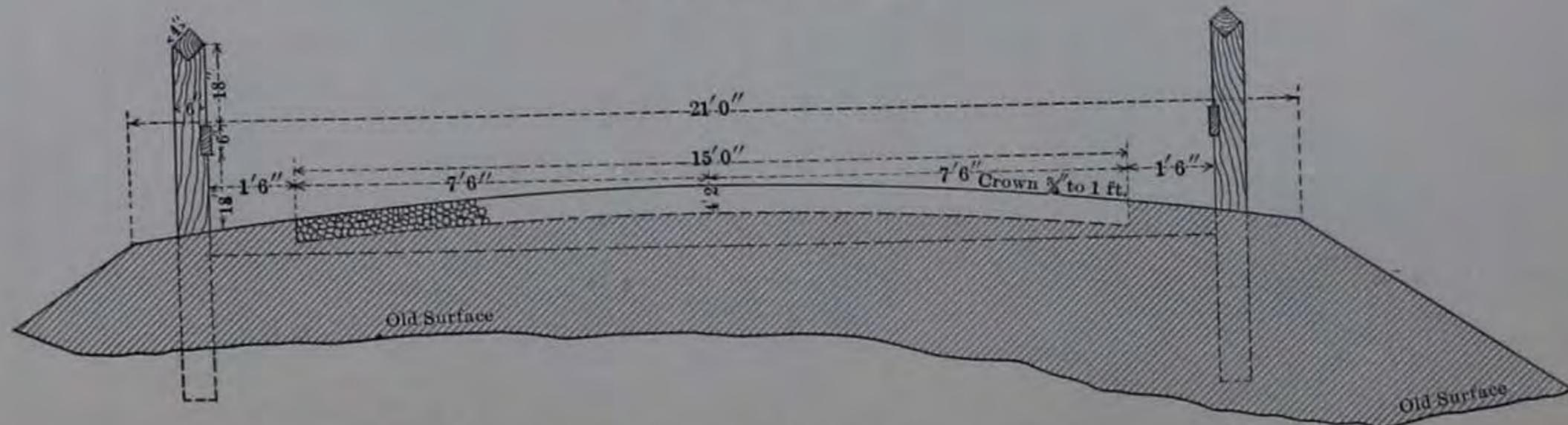

FIG. 26.—Standard Cross-Section Showing Macadam Pavement with Guard Rail (Mass.).

hard stone to the depth of 6 ins. Four of these 6 ins. to be first put on and worked in by carriages and horses; care being taken to rake in the ruts until the surface has become firm and consolidated, after which the remaining 2 ins. may be put on.

“The whole of this stone should be broken into pieces as nearly cubical as possible, so that the largest piece in its largest dimensions may pass through a ring of $2\frac{1}{2}$ ins. inside diameter.

“The paved spaces on each side of the middle 18 ft. should be coated with broken stone or well-cleaned gravel up to the foot-path or other boundary of the road so as to make the whole convexity of the road 6 ins. from the centre to the sides of it, and the whole of the materials is then covered with a binder of $1\frac{1}{2}$ ins. of good gravel free from clay or earth.”

Modern Stone Roads vary but little from the above types and then only in the minor details, the same general principles governing their construction and maintenance as those laid by Macadam and Telford.

Present practice requires, however, that the foundation upon which the stone is to rest shall be graded and thoroughly consolidated

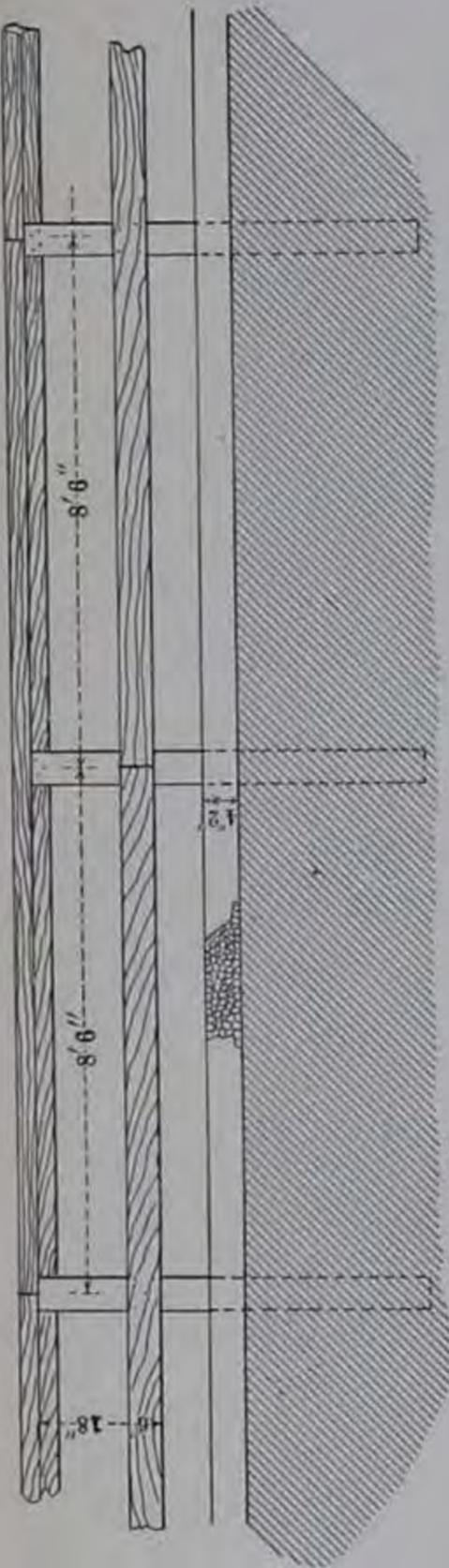

FIG. 27.—Longitudinal Section.

by a heavy roller until it conform in cross-section with that of the finished covering. Should any depressions result from this process, they must be filled with good loamy earth, and the

rolling continued until the soil is thoroughly compacted and true to grade.

In modern telford pavements, "after the roadbed has been rolled, a bottom course of stone is set by hand as a close firm pavement, the stones being placed on their broadest edges, lengthwise across the road in such manner as to break joints as much as possible, the breadth of the upper edge not to exceed 4 ins." No stones larger than 10 ins. long by 4 ins. wide may be used. This foundation course is settled by ramming or rolling, and upon

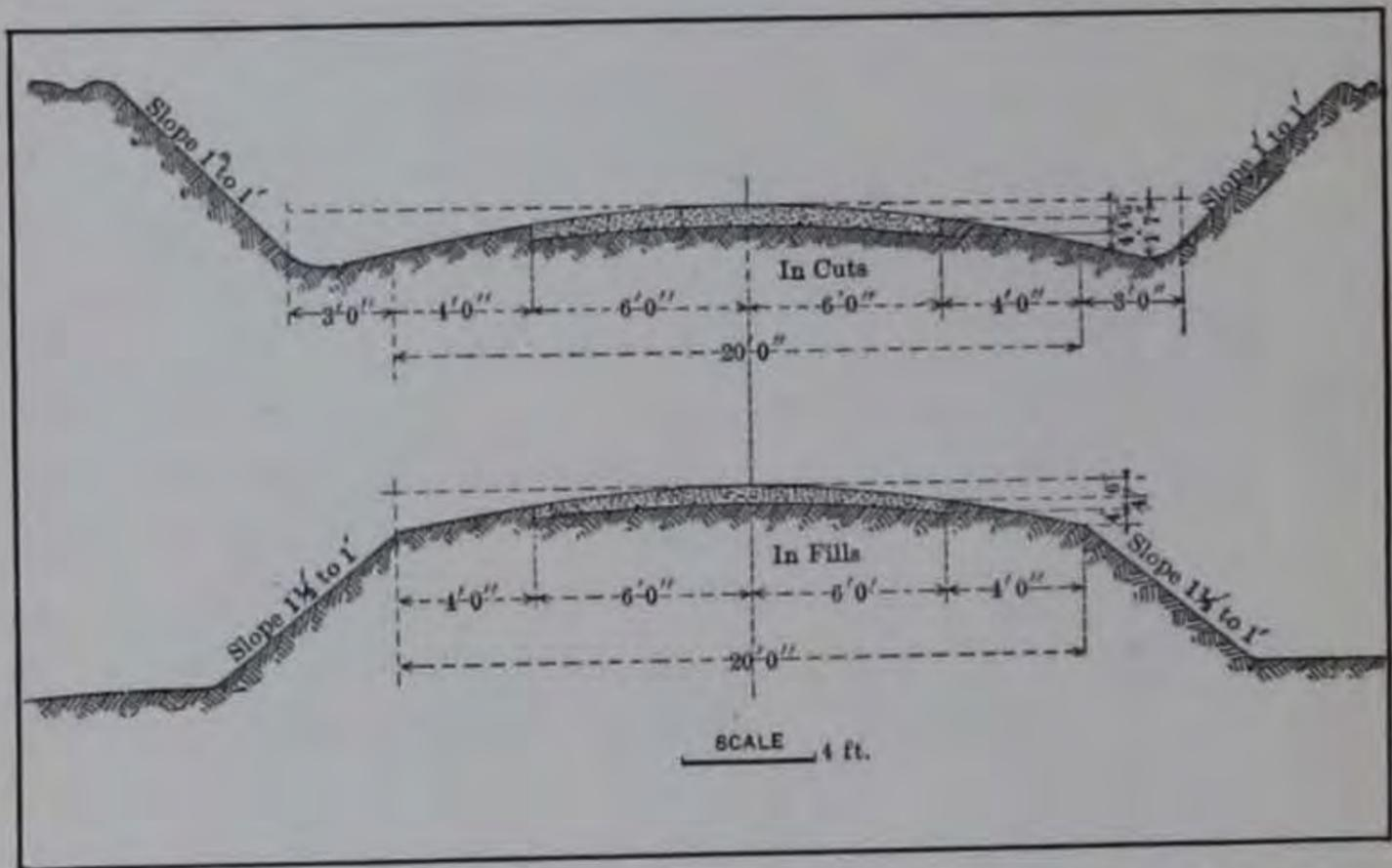

FIG. 28.—Standard Sections in Cut and Fill, as Built in Madison Co., Tenn.

it placed the successive layers of smaller stone as in a macadam pavement.

In modern macadam, the roadbed is prepared as above, but instead of a foundation being put down, the broken stone is laid directly upon the earth. The first layer of stone consists of two and one-half-inch fragments, or that passing a three-inch ring, deposited to the required depth, and repeatedly rolled until consolidation takes place.

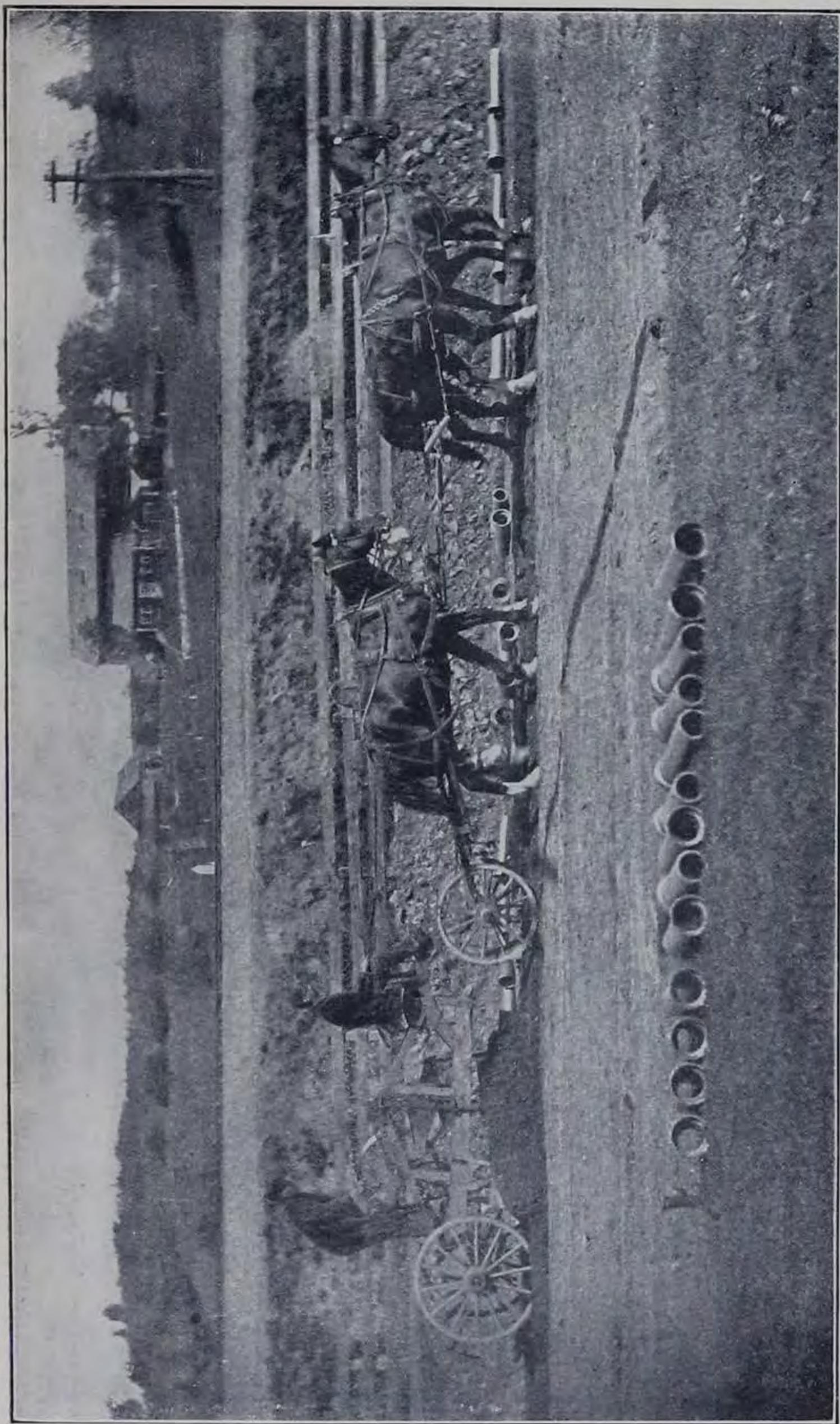

FIG. 29.—Road Machine Grading the Subgrade.

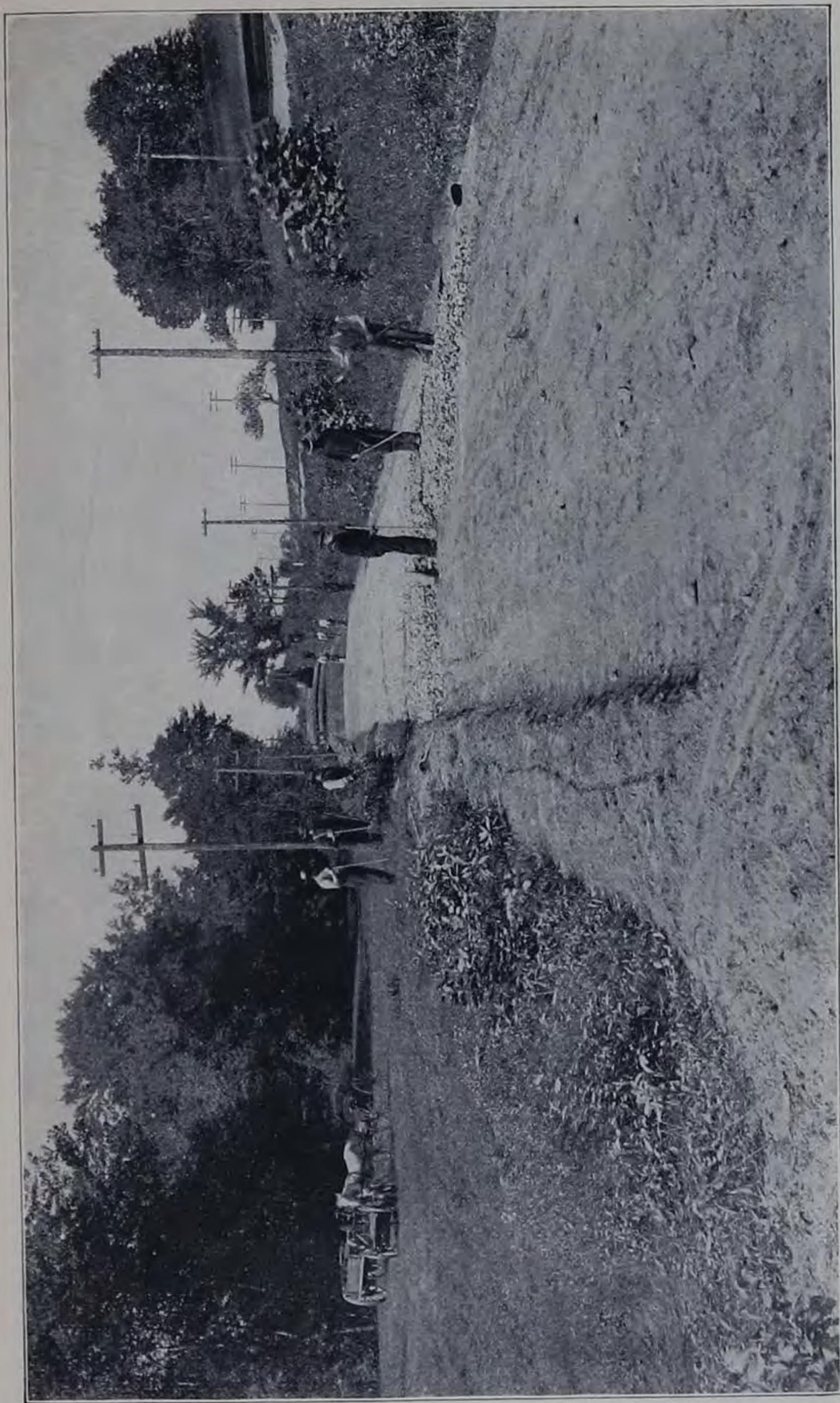

FIG. 30.—Subgrade Graded and Rolled, with some Broken Stone in Place.



FIG. 31.—Broken Stone Being Put in Place on the Prepared Subgrade.

Over the first course binder may be spread and rolled until it has worked into the interstices and the stones cease to creep or sink before the roller. A second course of $1\frac{1}{2}$ in. stone is laid on this, and treated as in the above. Upon this finally is laid a coat of 50 per cent $\frac{3}{4}$ in. stone; and 50 per cent screenings well mixed, which is again subjected to rolling.

TESTS ON ROAD STONE. The following abstract, substantially as it appeared in an article on "Current Practice in Laboratory Tests of Road Materials," by Prof. A. Black, indicates the method of making tests on road stone to determine its suitability to such purposes.

The qualities required in a good road stone are *hardness*, *toughness*, and *binding or cementing properties* of the finer abraded material; also, to a less extent, the ability to resist the disintegrating action of the weather, and, probably, of some organic acids produced by the decomposition of excretal matters always present upon roadways in use.

"By hardness is meant the power possessed by a rock to resist the wearing action caused by the abrasion of wheels and horses' feet. Toughness, as understood by road builders, is the adhesion between the crystals and fine particles of a rock, which gives it power to resist fracture when subjected to the blows of traffic. This important property, while distinct from hardness, is yet intimately associated with it, and can, in a measure, make up for a deficiency in hardness. Hardness, for instance, would be the resistance offered by a rock to the grinding of an emery wheel; toughness the resistance to fracture when struck with a hammer.

"Cementing or binding power is the property possessed by the dust of a rock to act after wetting as a cement to the coarse fragments composing the road, binding them together and forming a smooth, impervious shell over the surface. Such a shell, formed by a rock of high cementing value, protects the underlying material from wear and acts as a cushion to the blows from horses'

feet, and at the same time resists the waste of material caused by wind and rain, and preserves the foundation by shedding the surface water. Binding power is thus probably the most important property to be sought for in a road-building rock, as its presence is always necessary for the best results.

“ The hardness and toughness of the binder surface, more than of the rock itself, represents the hardness and toughness of the road, for if the weight of traffic is sufficient to destroy the bond of cementation of the surface, the stones below are soon loosened and forced out of place. When there is an absence of binding material, which often occurs when the rock is too hard for the traffic to which it is subjected, the road soon loosens or ravel.

“ Experience shows that a rock possessing all three of the properties mentioned in a high degree does not under all conditions make a good road material; on the contrary, under certain conditions it may be altogether unsuitable. As an illustration of this, if a country road or a city parkway, where only a light traffic prevails, were built of a very hard and tough rock with a high cementing value, neither the best, nor, if a softer rock were available, would the cheapest results be obtained. Such a rock would so effectively resist the wear of a light traffic that the amount of fine dust worn off would be carried away by wind and rain faster than it would be supplied by wear. Consequently, the binder supplied by wear would be insufficient, and if not supplied from some other source the road would soon go to pieces. The first cost of such a rock would in most instances be greater than that of a softer one, and the necessary repairs resulting from its use would also be very expensive. . . .

“ The degree to which a rock absorbs water may also be important, for in cold climates this to some extent determines the liability of a rock to fracture by freezing. It is not so important, however, as the absorptive power of the road itself, for if the road holds much water the destruction wrought by frost is very great. This trouble is generally due to faulty construction rather than



FIG. 32.—Laying a Telford Foundation.

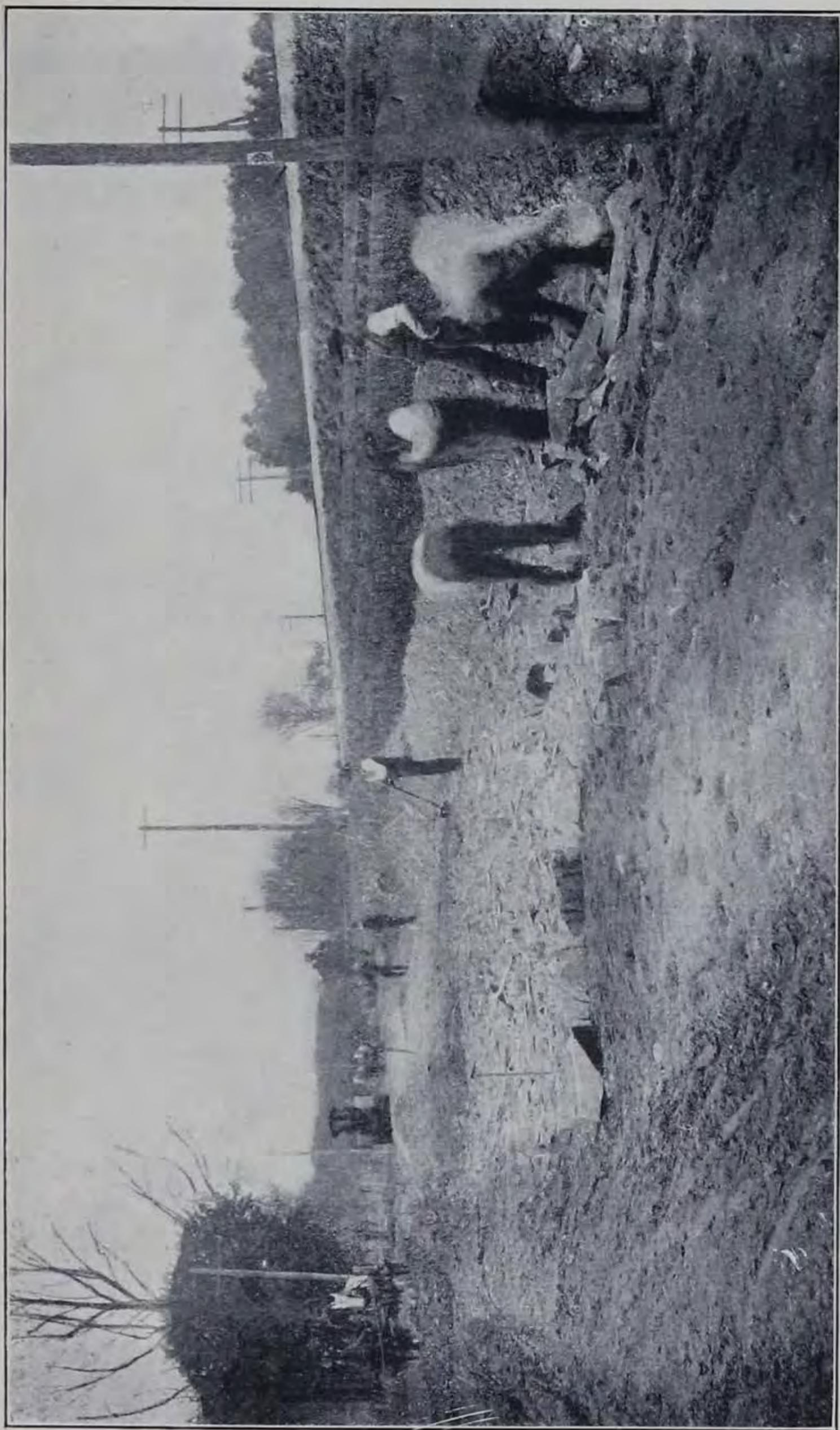

FIG. 33.—Telford Road in Process of Construction.



FIG. 34.—Steam Roller at Work on Finished Road.



FIG. 35.—Completed Road.

to material. The density or weight of a rock is also considered of importance, as the heavier the rock the better it stays in place and the better it resists the action of wind and rain."

These qualities are seldom found together in the same stone. Igneous and silicious rock, although frequently hard and tough, do not consolidate so well, nor so quickly, under the traffic as limestone, owing to the fact that the sandy detritus formed by such rocks has no cohesion; while the limestone yields a fine material which acts like mortar in binding the individual stones together. A stone with good binding properties will frequently wear much better than a harder and tougher material deficient in such properties. The engineer, therefore, is often called upon, in selecting a road material, to make a judicious compromise between the different requisite characteristic properties of a first-class roadway, to suit the particular conditions and the special problems presented; and it is the object of the testing laboratories to furnish him with the necessary data for this purpose.

Resistance to Abrasion. The apparatus used for this test is essentially the old Deval machine used in France since 1878 or earlier. In its original form it consisted of 2 iron cylinders, each 20 cm. in diameter, and 34 cm. long, interior measurements. Each cylinder was closed on one end, and had a specially fitted cover on the other, which, by means of a leather gasket, could be bolted on air-tight. The cylinders were attached to a horizontal shaft, to which they were inclined at an angle of 30 degrees and about which they were rotated by means of a pulley wheel fastened to the shaft.

The abrasion machines of to-day are essentially as that described above, except that there are four cylinders on the same shaft, so that it is possible to make four abrasion tests simultaneously. A counter is used for recording the number of revolutions. Fig. 36.

The material to be tested is broken into pieces from one and

one-fourth to two and one-half inches in diameter, the sizes usually employed on roadways, and as nearly cubical as is practicable with the appliances ordinarily used for such work. These stones should be thoroughly washed and, if necessary, scrubbed, to remove all dust and foreign matter; and should then be allowed to dry for several days before being used. Five kilograms of the clean broken stone, accurately weighed, constitute the charge for each cylinder. The cylinders being charged, the covers are bolted on securely, and the shaft rotated at the rate of 2,000 revolutions per hour, for five hours. Each rotation throws the pieces

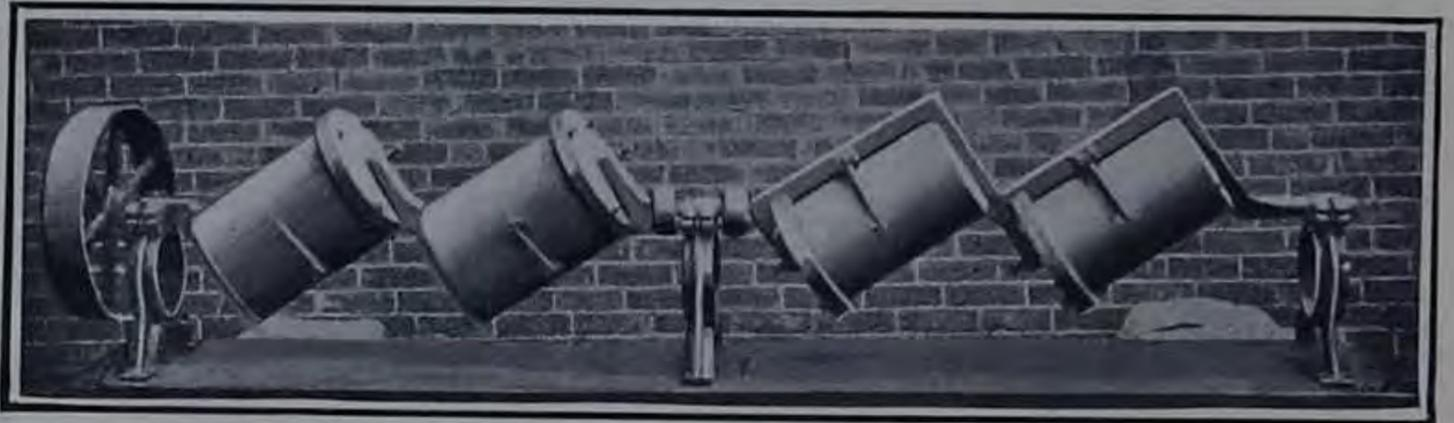

FIG. 36.—Abrasion Machine for Macadam Material.

of stone twice from one end of the cylinder to the other, causing them to grind against one another and against the sides and ends of the cylinders.

When the counter has recorded 10,000 revolutions, the machine is stopped, the covers unbolted, and the contents carefully scraped and brushed out of the cylinders into the upper of 2 superimposed sieves, having 16 and 100 meshes to the linear inch respectively. These sieves rest on the edge of a broad pan which receives all that passes through them.

The material retained on the upper, or coarser, sieve is thoroughly washed, and then put aside to dry for about two days. It is then carefully weighed, its weight deducted from the original cylinder charge, and the difference recorded as *loss due to abrasion*; for it has been agreed to consider as *abraded* all that passes the sieve with sixteen meshes to the linear inch; while the larger

particles retained on that sieve are assumed to be the original pieces reduced by wear, or broken into smaller pieces by impact.

This simple method, by differences, of determining the abrasion loss should always be used in preference to the laborious and not more accurate method, sometimes prescribed, of weighing directly the finer material, which involves the thorough washing of the cylinder to remove the adhering dust, and the washing of the larger particles in the same water, which must then be filtered, the filtrate, when dry, mixed with the cylinder detritus previously set aside, and the mixture sifted on the sixteen-mesh sieve, the material passing through this sieve being then weighed.

The numerical value for the abrasion of the specimen may then be stated in either of two ways: by the percentage, by weight, of the original charge that has been worn off by abrasion; or the French coefficient of wear may be used, which has been developed from the following considerations:

In the earlier French tests a rock of superior wearing qualities was always placed in one of the cylinders as a standard of comparison; and the ratio of the weights abraded, in the case of the standard rock and of the specimen under test, was supposed to indicate their relative resistances to abrasion. It was soon found that only the best varieties of rock produced less than 20 gm. of abraded material per kilogram of original charge; the number 20 was, therefore, adopted as a "standard of excellence," and the coefficient of wear for any stone tested was obtained from the formula:

$$\text{Coefficient of wear} = \frac{20 \times 20}{w} = \frac{400}{w}$$

in which w represents the weight in grams abraded per kilogram of original charge.

When the value of the resistance to wear by rubbing is required, the Dorrey machine is employed. The standard method of the French School of Roads and Bridges is as follows:

The specimens to be tested are cut into rectangular prisms, 4 cm. by 6 cm. base, and 8 cm. high. They are tested in sets of 2, and are held in clamps against the upper surface of a circular grinding disk of cast iron, on opposite sides of, and 26 cm. from, the centre. The specimens are weighted to press against the grinding disk, with a pressure of 250 gm. per sq. cm. Sand, obtained by crushing quartzite and screening to standard size, is fed onto the disk through a funnel, allowing 1 litre of sand, per specimen, for each 1,000 turns. The disk is rotated at the rate of 2,000 revolutions per hour, for 2 hours, or 4,000 revolutions for a test.

After 2,000 revolutions the specimens are reversed, to take into account a possible difference in texture in the 2 parts. The diminution in height is measured, and the loss in weight determined, after each 1,000 turns of the disk. Tests should be made on at least 3 samples of each specimen, and their average taken as the final result. Usually the loss in height after 4,000 revolutions is used in comparing different road stones; and frequently a specimen of some standard rock, as Yvette sandstone, is placed on the disk and tested with the other specimens, and the reduction in height referred to that of the standard.

This method has not come into general use in road-material laboratories in the United States.

The Cementation Test.—The purpose of the cementation test is to obtain the relative binding powers of the various stones used in road-making. Good binding power has long been known to road builders to be one of the most important properties possessed by a satisfactory road stone. If the fine material of a road binds well, it protects the coarser stones beneath from wear, withstands better the action of wind and rain, and prevents water from getting to the foundation of the road. Cementing power is thus seen to be a very important and valuable property of any road material. Experiments had been carried on for some five years, in the laboratory of the Massachusetts Highway Commission, to

determine some way of testing this important property. The test finally adopted was an impact test, to which stone-dust briquettes are subjected. The method in quite general use until recently is as follows:

To make a briquette, dust that is to be tested is passed

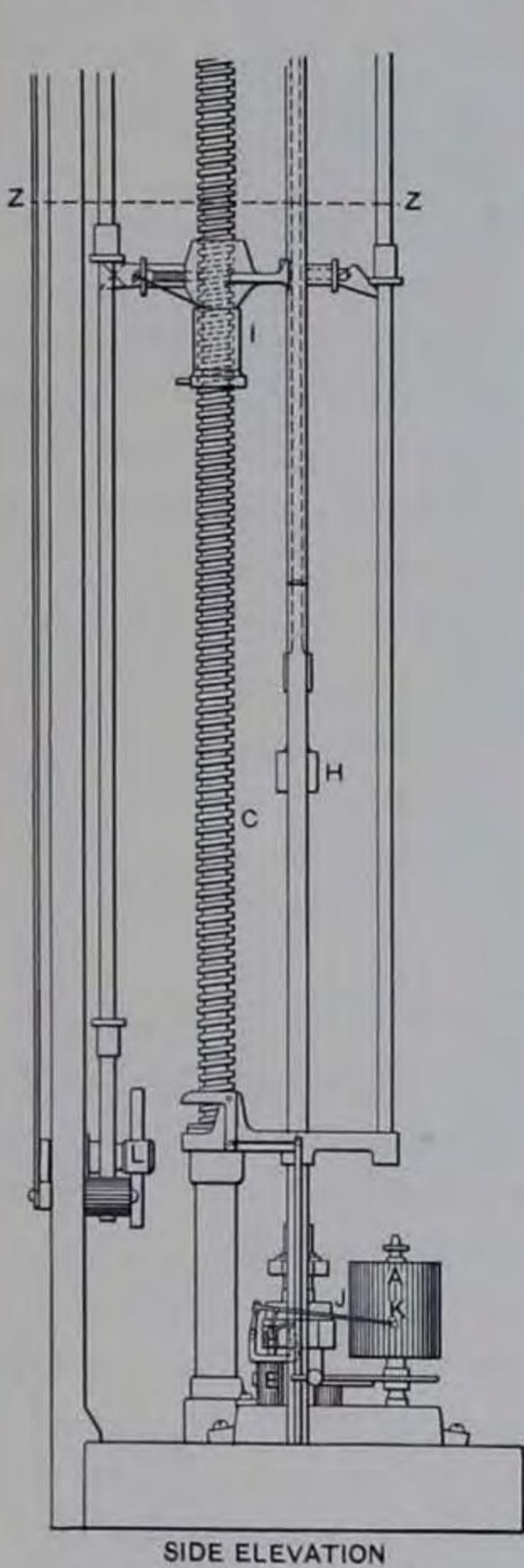

FIG. 37.

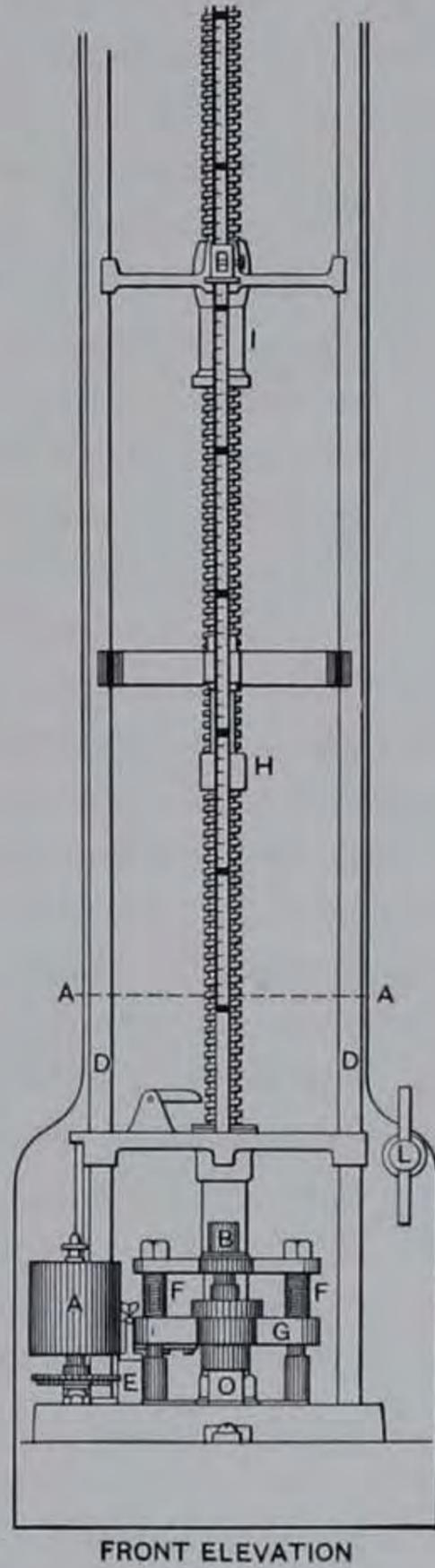

FIG. 38.

through a screen with 100 meshes to the linear inch and is obtained either from the detritus of the abrasion test or by specially reducing the stone. The reduction can be accomplished by placing some fragments of the stone in one of the cylinders of the abrasion machine together with one or more steel weights, and allowing the machine to run until a sufficient quantity of the stone is pulverized. The dust is made into briquettes of circular section, 25 mm. in diameter and 25 mm. in height, by placing in a metal die of proper dimensions, the dust mixed with only enough distilled water to moisten it (about 4 cu. cm.), inserting a closely fitting plug on top of the wet dust, and subjecting it to a pressure of 100 kilog. per sq. cm. The necessary weight of dust varies with the density and compressibility of the material, but generally it requires about 25 gm. of dust to make a briquette of the above dimensions. Two weeks are usually allowed for the briquettes to dry, at the ordinary temperatures of a room.

Cuts of the machine for testing these briquettes are shown in Figs. 37 and 38. It consists of a 1-kilogram hammer (H), arranged like the hammer of a pile driver, on two vertical guides (D). The hammer is raised by a screw (C), and dropped automatically from any desired height. It falls on a plunger (B), which rests upon the briquette (O) to be tested. The plunger (B) is bolted to a crosshead (G), which is guided by two vertical rods (F). A small lever (J), carrying a pencil (K) at its free end, is connected to the side of the crosshead by a link motion, arranged so that it gives a vertical movement to the pencil six times as great as the movement of the crosshead. The pencil is pressed against a drum (A), and its movement is recorded on a slip of paper fastened thereon. The drum is moved automatically through a small angle at each stroke of the hammer; in this way a record is obtained of the movement of the hammer after each blow. The standard fall of the hammer for a test is 1 cm., and the blow is repeated until the bond of cementation of the material is destroyed. The final blow is easily ascertained; for, when the ham-

mer falls on the plunger, if the material beneath it can withstand the blow, the plunger rebounds; if not, the plunger stays at the point to which it is driven, the elasticity of the material being

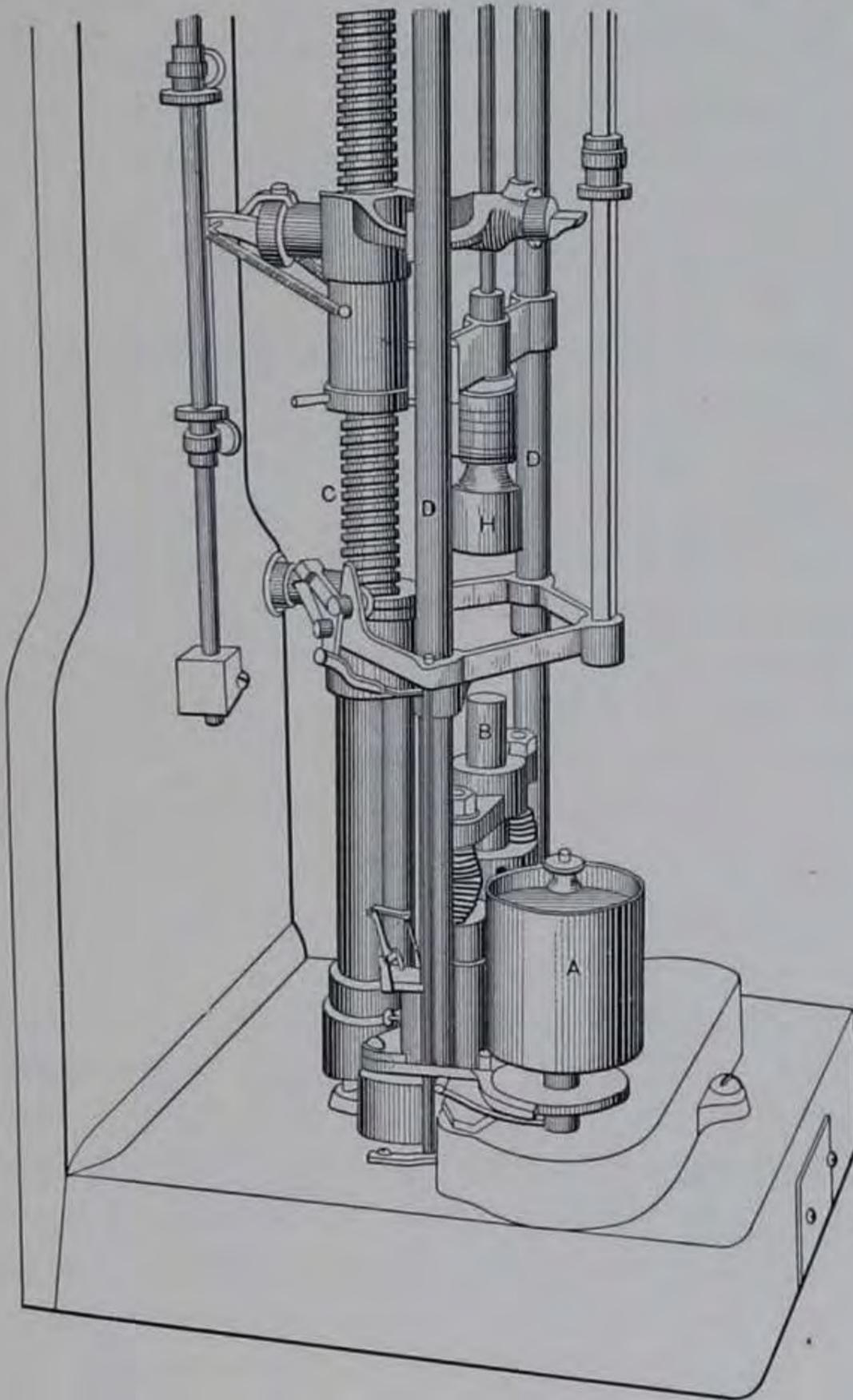

FIG. 39.

completely destroyed. The automatic record thus obtained from each briquette is filed for future reference. The *number of*

blows required to break the bond of cementation, as described above, is taken as representing the binding power of the stone, and is so used in comparing this property in different road materials.

Considerable difficulty has been experienced in keeping the briquette rigidly in place under the plunger, so that it should not be subject to lateral movements and complex stresses under the blows of the hammer. The usual device depended upon is a small brass plate fastened to the base of the machine, with a bevelled



FIG. 40.

hole slightly larger in diameter than the briquette; this has proved quite unsatisfactory, for the induced side thrusts frequently cause the lower edge of the briquette to crumble away under the successive blows, and failure of the test specimen to take place under too small a number of blows.

In the laboratory of the U. S. Department of Agriculture various clamping devices were tried and rejected. Finally the method was adopted of securing the briquette to the bed plate by means of shellac.

In preparing the stone dust for the cementation test, an automatic screen, about 100 cm. long by 10 cm. in diameter is used. It consists of a cylinder mounted on bearings at a slight angle with the horizontal, made of brass wire netting of 2 different meshes, 16 and 100 per linear inch, respectively. Into the upper end of the rotating cylinder the unscreened dust is automatically fed from a hopper, and in its passage is sifted into the 2 sizes. The upper end of the cylinder rests on wheel bearings, and on the bearing surface are several ridges which lift the cylinder whenever they pass over the wheels. This shaking device was introduced with the view of preventing the finer meshes of the screen from

clogging. As the apparatus is completely covered, no dust can escape into the air.

The making of the briquettes requires considerable skill and watchfulness, if the results of the test are to mean anything. The amount of water to be applied varies with the nature of the material, and can be determined only by trial. The object sought is to have the wet dust of the various specimens of the same consistency. With the small quantities of dust used for each briquette, a few drops more or less will vary the consistency quite noticeably, and with it, the degree of compacting of the mixture under the lever compression machine, which will inevitably appear in the variation of the results of the cementation test.

When the fine abraded material of a given specimen is sifted, the finest particles pass through first, and what subsequently passes is coarser and coarser, until only a few particles of the "size of separation" of the sieve will pass. Unless the dust which has passed through the sieve is thoroughly mixed, the briquettes will give discordant results on a test, the finer material, in general, exhibiting greater binding power.

A *ball mill* (Fig. 41) has been adopted as the standard for preparing the dust in a uniform manner. It consists of a flat, circular, cast-iron chamber containing 2 chilled-steel balls, weighing 25 lbs. each, and of slightly smaller radius than that of the rim of the chamber. One kilogram of rock fragments which will pass through a 6 mm. opening, but not through a 1 mm. opening, is put in the chamber and rotated for 2½ hours, making 5,000 revolutions. The ground material is then passed through a sieve made of No. 7 silk bolting cloth, with 3 meshes to the millimetre, and the briquettes are moulded from the dust passing through.

In moulding briquettes for the cementation test, the Washington laboratory has modified the usual procedure. The fine dust is mixed with water and kneaded to the consistency of a stiff

dough, which is kept in a closed jar for 24 hours. It is then made up in the usual way into briquettes, which are allowed to dry for 12 hours in the air, and are then placed in a steam bath, where they remain for 12 hours. After cooling in a desiccator they are tested in the customary manner. This modification was suggested by the results of certain experiments which showed that

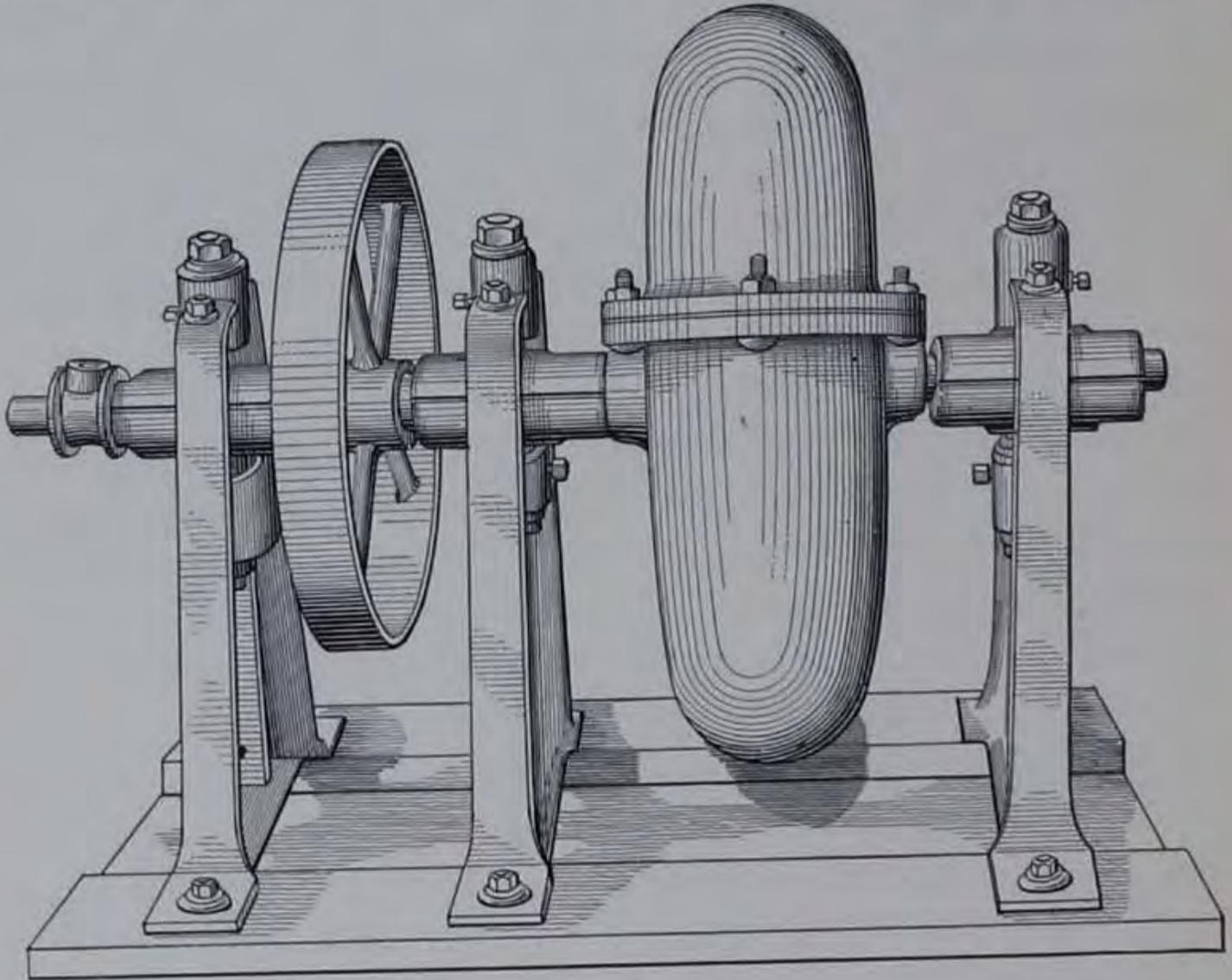

FIG. 41.—Ball Mill.

the cementing value increases progressively if the dough made from the rock dust is allowed to stand for some time before being moulded; and the increase is greater if the dough had been previously well kneaded.

Tests of many varieties of rock dust show that the more finely they are pulverized the higher will be their cementing value when moulded under pressure, either with or without moisture; and the greater the pressure the higher the value. Of two sets of

briquettes made with the same rock dust, one moulded wet, the other dry, the former invariably yielded the higher result; and, within certain limits, the more wet the material the higher the cementing value. That this is not due to a chemical change induced by the action of water has been shown by testing briquettes made of pulverized glass mixed with alcohol, which yielded like results. It was formerly thought that the water added to a rock dust acted merely as a lubricant to the fine particles, allowing them to slide over each other more easily under pressure, and thus mechanically interlock.

Until quite recently the cementation values have been obtained by the method first described here, and most of the published reports of such tests must be read with this understanding.

The cementation test as practised at present is not entirely satisfactory, although the modifications introduced in the Washington laboratory constitute a notable advance. It is difficult to obtain uniform and comparable results; and, further, it would appear desirable that the character of the test specimen should approximate, as nearly as may be practicable, the condition of the material on the roadway. This may be approached by making the briquettes of a mixture of the fine dust, obtained as usual, and a definite quantity of some aggregate, preferably coarser particles of the same sample, sifted to some standard degree of fineness. The best proportional quantities, and the best size of aggregate to be used, can be determined only after numerous comparative experiments. The size of the test specimen might well be made larger, to reduce the influence on the result of small accidental defects in the piece. It is entirely analogous to the testing of briquettes of hydraulic cement made neat, or with the proper admixture of a standard sand, the latter giving the more valuable and practical information.

Furthermore, since the surface of a broken-stone road is being constantly abraded, dried, moistened, and recemented, it would

seem to be desirable to also determine the *recementing* properties of the specimens, thus furnishing additional information of special practical significance. Formerly this was done in the following manner: a set of briquettes of *constant weight*, instead of constant height, was made and tested, and the broken-down material was made into a new set of briquettes, and again tested to failure. The number of blows in the second case gave the value of the recementing power of the fine dust.

Toughness Test. This test is made on 25 mm. by 25 mm. rock cylinders, with the impact machine used for testing the briquettes of rock dust. Instead, however, of a flat-end plunger resting on the test piece, as in the cementation test, a plunger with the lower-end bearing surface of spherical shape, having a radius of 1 cm., is used. It can be seen that the blow as delivered through a spherical-end plunger approximates as nearly as practicable the blows of traffic, and it has the further advantage of not requiring great exactness in getting the two bearing surfaces of the test piece parallel, as the entire load is applied at one point on the upper surface. The test piece is adjusted so that the centre of its upper surface is tangent to the spherical end of the plunger, which is pressed firmly upon the piece by two spiral springs surrounding the plunger guide rods. The cylinder is held to the base of the machine by a device which prevents its rebounding when a blow is struck by the hammer, which weighs 2 kilos. The test consists of a 1 cm. fall of the hammer for the first blow, and an increased fall of 1 cm. for each succeeding blow until failure occurs, the *number of blows* required to cause failure being taken to represent the toughness. The cylindrical test pieces may be made with a core saw designed for the purpose.

Resistance to Crushing. The *ultimate compressive resistances* of cubes of the material is determined in the usual manner by subjecting them to pressures, and is expressed, generally, in pounds per square inch. Briefly described, the crushing test is performed by placing a cubical specimen of the material to

be tested on the steel platform of the testing machine, and mechanically applying pressure by means of a cross-head which is made to approach the test piece from above. The total pressure applied is determined by noting the number of pounds recorded

TABLE SHOWING THE QUALITIES OF SOME ROAD STONE

Locality of Quarry.	Name of Rock.	Wear.		Cementation Value.	Where Used.
		Coefficient.	Per cent		
<i>Albany County, N. Y.</i> Quarries $\frac{1}{2}$ mile north from Dunsbach Ferry station on N.Y.C. & H.R.R.R. on s. side of Mohawk river.....	Hudson river sandstone.....	6.78	5.96	50	{ Used for top and base of section 2 of Loudon road, No. 119, from Albany to Cohoes, built during 1903 by the State.
<i>Chemung County, N. Y.</i> Wells Quarry, 3 miles west of Elmira, N. Y.....	Chemung grit.....	5.82	6.88	24	{ Used during 1901 for base of $3\frac{1}{2}$ miles of the Southport road to the south boundary of New York State, built by State.
<i>Chenango County, N. Y.</i> From ledge 5 miles north of Norwich, on farm of Loren Cushman, 300 feet west of Norwich and Plymouth road No. 112.....	Sandstone.....	6.80	5.88	26	{ Used during 1902 for base top 2 miles of Norwich and Plymouth road No. 112, built by State.
<i>Cortland County, N. Y.</i> From ledge on farm of O. G. Kellogg, $2\frac{1}{2}$ miles s.e. from Cortland, N. Y.....	Calcareous sandstone.....	7.07	5.65	30	{ Used during 1902 for base of 1 mile of road south from Cortland, Blodgett's Mills road, No. 111, built by State.
<i>Clinton County, N. Y.</i> Plattsburgh, Clinton county, N. Y., Moore's Quarry, north side of village.....	Clinton blue limestone.....	6.87	5.82	11	{ Used during 1901 for base and top and filler of $\frac{1}{10}$ mile of Plattsburgh and Keeseville road, built by State.
Five miles south of Plattsburgh, N. Y., quarry on north bank of Salmon river.....	Clinton gray limestone.....	10.94	3.66	25	{ Used during 1901 for base and top and filler of $2\frac{1}{2}$ miles of Plattsburgh and Keeseville road, built by State.

by the balanced scale beam at the time of failure. This value, divided by the area of the section over which the pressure is distributed, gives the required quantity, *i.e.*, pounds per square inch.

The Absorption Test as made by the Massachusetts State Highway Commission consists in taking a smooth specimen that has been subjected to the impact and abrasion test, and which weighs about 40 gms. and weighing it in air. It is then immersed in water, where it is immediately weighed, and allowed to remain for ninety-six hours, at the end of which period it is again weighed in the water as it is supposed to have become completely saturated. From the recorded weights the absorption is computed by the following formula.

Pounds of water absorbed per cubic foot of stone =

$$\frac{C-B}{A-B} \times 62.5$$

Here A = weight in air,

B = " directly after immersion,

C = " after ninety-six hours.

The specific gravity and weight per cubic feet would be obtained in the customary way. If a petrographic examination is required to classify the rock, a thin section of the specimen is taken and studied under the microscope.

The rocks most commonly used, most nearly satisfying the requirements of the above tests, and which, from actual service, have been shown to be best suited for road-building purposes, are trap, granite, limestone, sandstone, fieldstone, and shale, in the order of their importance.

It should be remembered, however, that in making a selection, traffic and cost should be studied, and cost of maintenance and construction taken into account.

TRAP is a hard and tough igneous rock, very fine-grained and eminently suited to road-building purposes. It wears well, and yet yields enough dust to make up for that which has been car-

ried away by wind, rain, or other causes. This dust in itself possesses superior cementing qualities, so that the individual stones are bonded together as though with cement.

It is, perhaps, the best road stone that may be had, but it is found in comparatively few districts, so that it is expensive. Frequently where the cost is excessive an inferior or cheaper local rock is used for a foundation while a thin layer of trap is placed on top of this to take the wear.

GRANITE is a massive rock, granular in texture and composed principally of quartz, feldspar, mica, and hornblende. The presence of the quartz makes the rock brittle, the feldspar is readily decomposed, while the mica splits easily. In spite of these facts, because of its hardness it wears well, and makes a good road stone. Syenite, which is a form of granite with the quartz absent, makes the best surfacing material.

LIMESTONE is frequently and satisfactorily used on roads where the traffic is light, for it possesses superior binding qualities; but it is neither tough nor hard, so that it is easily reduced to a powder to be washed or blown away. Very often, however, limestone will be mixed with other material in which the binder is lacking, to produce its more complete and rapid consolidation.

SANDSTONE consists of a mass of fine grains of silica bound together by some cementing material, and depends for its strength upon the nature of this cement. Because of its structural weakness it is not a very satisfactory road stone, as it readily disintegrates, leaving a mass of loose sand grains.

FIELD STONE, or crushed gravel, is often used on gravel or broken-stone roads, either alone or mixed with some other material, and is eminently suited to the purpose provided the stone is undecomposed and uniform in character. Lack of uniformity will, however, produce an uneven surface after a little wear.

SHALE, which is an indurated clay, is of two kinds: the argilla-

aceous or clayey shale, and the arenaceous or sandy shale. The former is without value, while the latter is extensively used, particularly as a top dressing for stone roads.

FORMS OF CONSTRUCTION. There are two general forms of construction, surface and trench. The former name is applied to that in which the stone is distributed in a layer over the surface,



FIG. 42.—Excavating and Preparing Roadbed for Macadam Surface. Trench Construction.

and where consolidation usually occurs by means of the traffic. It is not a particularly good way to build broken-stone roads; but, on the other hand, the results are not particularly bad if due care is exercised, and it is cheap.

With the other form, a trench of proper dimensions is dug along the line of highway and, after proper grading, rolling, and other preparation, the broken stone is placed in this. The advantage of the latter type is that the shoulders keep the stone in place, thus preventing spreading. Trench construction is used for both macadam and telford pavements.

The transverse profile of the subgrade may be either flat or have the same crown as that of the final surface. In the former case the greater amount of material is where the most traffic comes, *i.e.*, in the centre of the road, which is claimed to be an advantage as it distributes the pressure better. The more general practice, however, favors a subgrade parallel to the surface and, of course, requires less material.



FIG. 43.—Macadam Pavement Supported at Sides by Shoulders of Earth, Trench Construction.

In preparing the subgrade it is better to use a steam roller of 10 to 15 tons, with a pressure of 500 lbs. per lineal inch of tire, than either a hand or horse roller, as it is quicker, heavier, less expensive, and secures a more perfect consolidation.

Wherever necessary, subsurface drainage should be installed as no amount of rolling will make a satisfactory foundation where the soil is wet or in a position to become so.

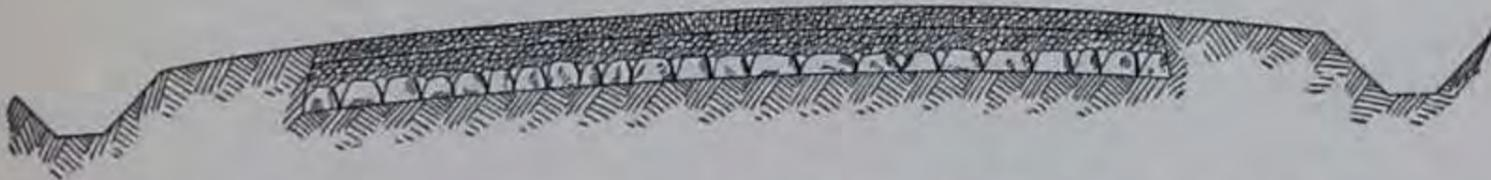

FIG. 44.—Telford with Macadam Surface, Trench Construction.

THICKNESS OF STONE COVERING. Upon the prepared subgrade is spread the broken stone in layers and to a depth depending upon "the soil, the nature of the stone used, method of repairs, and the amount of traffic which the road is expected to have. It should be so thick that the greatest load will not affect the foundation. The weight usually comes upon a very small part of the surface, but is spread over a large area, and the thicker

the crust the more uniformly will the load be distributed over the foundation."

Where the traffic is heavy, naturally a thicker surfacing is required than where it is light; if the stone is easily crushed or broken, it is easily blown or washed away, and more metalling is needed than if it is hard and tough and capable of withstanding the effect of traffic; if the repairs are periodic, larger quantities

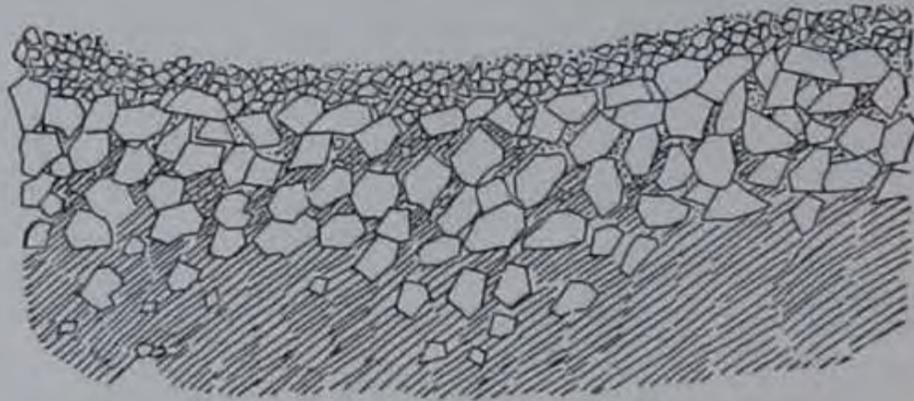

FIG. 45.—Cross-Section of Macadam Road Showing Results when Loose Stone is Placed on Wet Earth Foundation.

of stone must be applied at first in order to provide for wear between periods of repair.

The Massachusetts Highway Commission "has estimated that non-porous soils drained of water, at their worst will support a load of about four pounds per square inch; and, having in mind these figures, the thickness of the broken stone has been adjusted to the traffic. On a road built of fragments of broken stone the downward pressure takes a line at an angle of forty-five degrees from the horizontal, and is distributed over an area equal to the square of twice the depth of the broken stone. If a division of the load, in pounds, at any one point, by the square of twice the depth of the stone gives a quotient of four or less, then will the road foundation be safe at all seasons of the year. On sand or gravel the pressure may safely be placed at twenty pounds per square inch."

The above may be written

$$t^2 = \frac{w}{4p}$$

where

t = thickness of stone in inches;

w = weight of load in pounds per square inch per wheel;

p = supporting power of soil per square inch.

"Acting on this theory, the thickness of stone on the Massachusetts State roads varies from 4 to 16 ins., the lesser value being used on good gravel or sand, and the larger on heavy clay. In cases where the surfacing exceeds 6 ins. in depth, the excess may be broken stone, stony gravel, or ledge stone, the material used depending entirely upon the cost, either being equally effective."

Macadam used a thickness of ten inches in the roads he built, but the depth must necessarily vary with different conditions.

In New Jersey the following thicknesses, depending on grade, have been used:

Grade flatter than 1 per cent.....	10 ins.
Grade between 1 per cent and 4 per cent.....	8 ins.
Grade over 4 per cent.....	6 ins.

In general, however, it may be stated that the thickness varies between 4 and 12 ins. for macadam, with an average of 6 ins., and between 8 and 12 ins. for telford, with an average of 8 ins.

In Bridgeport, Conn., a thickness of 4 ins. has been used satisfactorily with loads averaging 6,000 lbs., but it is needless to say such roads must conform to the highest standards of construction and be maintained by a system of continuous repairs.

SIZE. "The size to which stone should be broken depends upon the quality of the stone, the amount of traffic to which the road will be subjected, and to some extent upon the manner in which the stone is put in place. If a hard, tough stone is em-

ployed, it may be broken into rough cubes or pieces of about one and one-half inches in largest face dimensions, and when broken to such a size the product of the crusher may generally be used to good advantage without the trouble of screening, since dust "tailings" and fine stuff do not accumulate in large quantities in the breaking of the tougher stone.

"If only moderate traffic is to be provided for, the harder limestones may be broken so the pieces will pass through a 2 in. ring, though sizes running from $2\frac{1}{4}$ to $2\frac{1}{2}$ ins. will insure a more durable roadway, and if a steam roller be used in compacting the metal it will be brought to a smooth surface without much trouble. As a rule, it may be said to adhere closely to a size running from $2\frac{1}{4}$ to $2\frac{1}{2}$ ins. in largest face dimensions, and to use care in excluding too large a proportion of small stuff as well as all pieces of excessive size will insure a satisfactory and durable macadam road." Where the traffic is light a top course of stone $\frac{1}{2}$ to 1 in. in size is employed, while for heavier loads 1 to 2 ins. is used.

Usually it is recommended to have the stone uniform in size, but in Massachusetts it is separated into three sizes of $\frac{1}{2}$ in., $1\frac{1}{2}$ in., and $2\frac{1}{2}$ ins. by passing through screens. The larger size is placed on the bottom with the smaller sizes in successive layers on top. The subgrade and each course is rolled separately, and the top course watered before rolling.

LAYING. In laying the stone it is probably better to strew it over the surface with a shovel than to dump it in heaps from carts and spread it later with forks and rakes. The former secures a more even distribution of the material, both as to size and quality, though it costs more.

The layers should be about four to five inches thick, depending upon the final thickness of the road, and rolling should be continued until each course is thoroughly consolidated. Under ordinary circumstances this will result when the course has been reduced from twenty to thirty per cent, but the standard of

judgment should be not the percentage of reduction, but the firmness of the pavement.

ROLLING. The amount of rolling depends upon several factors, such as weight of roller, size and hardness of stone, amount of binder and water used, nature of binder, etc. Where



FIG. 46.—First Course of Stone on a Macadam Road as it Appears when Ready for Rolling.

the binder is freely used together with an abundance of water, consolidation results more quickly than otherwise, but it is not as satisfactory as if less binder and more water were used with more rolling.

Hard stone requires more rolling than soft.

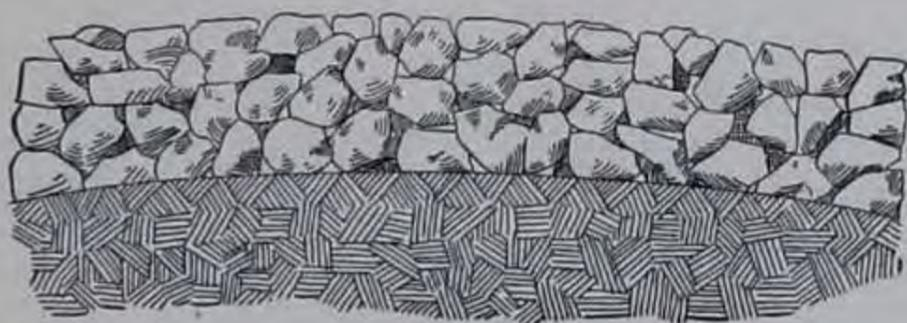

FIG. 47.—First Course of Stone Partially Rolled, Showing how the Roller Packs it.

In all cases rolling should proceed from the sides toward the centre so as to preclude the possibility of the stone thinning out at the edges, and the rolling at the sides should be completed before the roller proceeds toward the centre. Wetting the stone

during this process hastens the consolidation, "decreases crushing under the roller, and assists the filling of the voids with the binder."

THE BINDER may be screenings of trap, limestone, sandstone, shale, clay, or loam. It is applied to each successive layer, and liberally sprinkled with water for the purpose of producing the more complete consolidation of each course.

WIDTH. In Massachusetts the standard width of metalling is fifteen feet with shoulders of three feet at each side shaped to the same cross-section. Where the traffic is excessive these shoulders are covered with gravel, but otherwise the natural soil is used. Ten and twelve feet have been used, but the former has been



FIG. 48.—First Course Thoroughly Rolled. Small Stones, Gravel, Dirt, or Sand, if Present, Prevent Such a Complete Consolidation.

found to be uneconomical except under very light traffic. In New Jersey, the width varies between 9 and 16 ft., though the more common width is 10 to 12 ft.

The width of a stone road depends upon the amount of traffic, and is an important question to decide, as the stone is expensive. Frequently to save expense the central portion will be paved with the telford or macadam where the most travel comes, and wings will be employed at the sides to take the lighter traffic and to permit of turning out. These wings are part of the stone pavement, but of a less thickness, and without the foundation of cobble where telford is used. Beyond these wings there may be shoulders, or, if the wings are not present, the shoulders

are placed next the pavement, serving the purpose not only of holding the stone in place, but providing room for turning out as well.

CROSS-SECTION. The form of the profile may be either the intersection of two planes at the centre of the roadway or a curve in the form of a circle, ellipse, or parabola.

In the former case the ordinates are proportional to the distance from the centre; in the latter, or where the parabolic curve is employed, the ordinates are proportional to the square of the distance from the centre. The following rule may also be used: "Divide the roadway into 3 equal parts, and starting from the centre give a fall of .03 ft. per ft. for the 1st part, .04 ft. per ft. for the 2d, and .05 ft. per ft. for the 3d. If the roadway is very wide, divide the $\frac{1}{2}$ roadway into 4 parts, giving a fall of .02, .03, .04, and .05 ft. per ft. to the respective sections. If the roadway is narrow, divide the $\frac{1}{2}$ into 2 parts, and give falls of .04 and .05 ft. per ft. to the 2 sections respectively."

CROWN. The amount of crown will vary between a slope of 1 in 12 and a slope of 1 in 40, depending upon the method of making repairs, the longitudinal grade, and the width of roadway. Where the roadway is very wide, a smaller crown should be given to avoid an excessive rise at the centre with the consequent high velocities of surface waters. If at the same time the repairs are made continuously, a minimum crown will satisfactorily care for the water falling on the pavement. This, however, should never be less than the above minimum ratio. Where the road is narrow, the crown may be legitimately increased without fear of the surface waters damaging the roadway, and if along with this the repairs are made periodically, the maximum may be reached. Where repairs are periodic a greater thickness of metalling is given at the centre, to allow for the wear during the intervals between which repairs are made.

The effect of grade upon crown is shown in the following table from the Rhode Island Report:

Longitudinal Slope.	Transverse Slope.
$\frac{1}{2}$ to 4 per cent.	1 in 25
4 to 6 per cent.	1 in 20
6 to 9 per cent.	1 in 12 $\frac{1}{2}$

Repairs and Maintenance. "Repairs of stone roads should begin the day they are opened to traffic, as the attention they receive the first few months of use determines their usefulness and length of life."

Long experience having proven that the best results are obtained at a less cost by a system of continuous small repairs, the Massachusetts Highway Commission has adopted this method of maintaining that State's highways. The cost is equally divided between the roadway proper and the sides.

The durability of roads depends wholly upon the power of the materials of which they are composed to resist those natural and artificial forces which are constantly acting to destroy them. The fragments of which they are constructed are liable to be attacked in cold climates by frost, and in all climates by water and wind. If composed of stone or gravel, the particles are constantly grinding against each other and being exposed to the impact of the tires of vehicles and the feet of animals. Atmospheric agencies are also at work decomposing and disintegrating the material. It is obviously necessary, therefore, that great care be exercised in selecting for the surfacing of roads those stones which are less liable to be destroyed or decomposed by these physical, dynamical, and chemical forces.

The destructive agents of stone roads are wind, rain, frost, horses' hoofs, and wagon wheels. The following is abstracted from a report on Repairs of Macadam Roads by E. G. Harrison made to the Department of Agriculture, U. S. A.

The neglect of repairs to public roads is very poor economy. With the greatest possible care an earth roadbed cannot be made strictly uniform as to solidity, and heavy loads passing over the crust formed by the stones will press some of the stones into soft

places in the earth bed, and this in time will cause a defect on the surface of the road. A very slight depression will at first appear, which may be detected only after a rain (by the water which will remain for some time in the depression). If this depression is permitted to remain it will soon become deeper and broader. As the wagon wheels go in and out of it they grind out the stone softened by water, and cut down the sides, so that what was at first a slight depression soon becomes a hole. Such neglect causes subsequent repair to be expensive.

CAUSES WHICH MAKE REPAIRING NECESSARY

It will be well to consider some of the causes which make repairing necessary, so that they may be avoided or removed as far as possible. They are:

- (1) Defective construction of earth bed.
- (2) Failure to cut off underground water by drainage.
- (3) Rain or storm water which is permitted to lie in pools along the roadsides or in side ditches which do not carry the water from the road.
- (4) The side slope being insufficient to carry the storm water from the road to the side ditches.
- (5) The longitudinal grade of the road being greater than the slope from centre to sides.
- (6) The formation of ruts.
- (7) Ravelling, or picking up loose stone.
- (8) Surface stone not of proper quality and not uniform.
- (9) Roadbed not sufficiently compacted.
- (10) Accumulation of trash or rubbish on the road.

These causes will now be considered and remedies suggested:

- (1) Defective construction of the roadbed results in a subgrade which has not been thoroughly compacted, but contains spots of soft earth. This soft earth should be removed and replaced by other earth, so as to make the whole roadbed surface as uniform as possible. If this is not done, heavily loaded teams

passing over the finished road will press the stones down into the soft places, making depressions in the surface of the road which will be filled with water during rains. The water will afterward percolate through the stone bed, making the earth still softer, and the depression will soon become greater. The remedy in this case must be applied to the roadbed itself, for after the stone has been put in place defects in the roadbed cannot be cured.

Wherever a depression large enough to hold a shovel of broken stone appears in the surface of the finished road the loose material found in the hole should be taken out, the hole filled with new stone broken to a size not larger than one and one-half inches, and material taken from the hole spread over the broken-stone surface for a binding. It should then be compacted by ramming or rolling until it is made to correspond to the rest of the road surface. The broken stone should in no case be left lying loose, for this allows the storm water to pass through, and the earth continues to soften; moreover, many of the loose stones would be scattered over the road surface and would become not only bad for horses' feet and damaging to wagons, but uncomfortable for those who ride. Loose stone on a hard stone surface loosens the other stones when loaded teams pass over them.

(2) Many roadbeds become soft and irregular, because the underground water was not cut off by drains when the road was constructed. This is one of the principal sources of the many defects in roads which cause depressions and ruts. To remedy this defect, tile or stone drains should be placed a short distance from the roadbed on the side nearest to where the springs are supposed to have their source. If it is uncertain on which side of the road the springs rise, drains should be placed on both sides at sufficient depth to cut off the underground water. When water is permitted to pass under the roadbed, as soon as it strikes soft earth or sand it rises by capillary attraction to the surface and softens the earth bed. Much of the cost of road repairs could be saved by proper attention to drainage.

(3) Pools of water should never be allowed to remain along the roadside or in the ditches; the latter should always be kept open and clear, so that all storm water may pass to the nearest natural waterway. The surface on the sides of the paved roadway should always be kept at proper slope to carry water to side ditches, and no holes or obstructions of any kind allowed to stop the free passage of water from the road to the side ditches. Water in pools along the road will soften the earth, and much of it will pass down until it comes to a hard stratum and will then follow the dip of the stratum, which may take it under the stone construction, where it will act in the same way as water from springs. By proper attention this cause of repair can easily be avoided.

(4) When stone road surface has not been constructed with sufficient slope or grade from crown to side ditches, so that all the storm water does not pass off quickly, but remains in the slight depressions and wagon tracks, the road surface will become soft and will wear more easily. Dirt which is carried on by wagon wheels will also remain and accumulate when there is not sufficient grade to carry it off with rainfalls. The remedy is to place enough stone in the centre of the road to give it the required slope or grade, which should never be less than one-half inch to the foot. Care should be taken to keep the earth surface between the metal construction and the side ditches of the same grade, if possible, and in no case of less grade.

(5) When the longitudinal grade is greater than the slope from centre of road to side ditches, the water from rainstorms and melting snow will follow the metal construction with the run of the road, increasing in quantity and force according to the length of the grade, causing washes in the road surface.

It is better to construct a road on a grade not exceeding 5 ft. to the hundred, and then the slope can be made 6 or 7 per cent. But there are cases where it is not practical so to change the grade of the road as to reduce it to 5 per cent, and the road cannot be

relaid so as to avoid the steep grade. In such cases the best possible remedy must be applied. To take the water from the metal construction, a cut or depression can be made at certain intervals, starting at about two feet from the crown of the road and running diagonally with the grade to the side ditches, widening and deepening as it gets near to the side ditches. It need not be so deep as to inconvenience the travel, but deep enough to carry off the storm water. The greater the grade the more cuts will be required.

(6) Ruts are generally formed by the use of narrow tires on wagons carrying heavy loads. They are more easily formed when the road surface is soft, but narrow tires with heavy loads will cut out the stone and form ruts on the hardest surface, particularly on narrow roadbeds. A two-inch tire soon wears away on the sides so as to become only one inch wide on the bearing surface, and the whole weight of wagon and load is supported on about four square inches bearing on the road surface. When in motion it tears away the stone, making holes and forming ruts when allowed to run in the same tracks—a condition which cannot well be avoided on narrow roads. The ruts deepen and harden by use, and the horses, finding less resistance to the wheels in the ruts, will walk so as to get the wheels to follow the ruts. Wide tires will greatly prevent ruts, but even wide tires will make ruts if allowed to run continually in one track.

In order to distribute travel over the road so as to prevent the formation of ruts, this plan is recommended:

Have a double-tree made of such length that the ends will be in line with the wagon wheels. The single-trees to which the traces are hitched being attached to the ends of the double-tree will bring the horses directly in line with the wagon wheels, and the wheels will follow the horse and pass over the road where he steps. As the horse will not walk in a rut nor go into a hole unless compelled, the wagon wheels also will avoid them. If the horses' sharpened shoes should loosen any stones, the wide

tires of the wagon wheels following him will roll them into place again.

Another plan to prevent ruts, and at the same time to improve the road by use, is to make the axle-trees of the wagon of different lengths, so that the wheels on the front axle will not be followed by those on the rear axle.

(7) Ravelling or picking up loose stones is made possible by the moisture being taken from the binding material. The stones on the surface of the road become loose and are easily displaced both by the horses' shoes picking them up and by the wheels. This can be remedied only by applying water to the road surface, but, as it happens in dry, hot weather, the water when applied soon evaporates, and watering on country roads is expensive. If the lengthened double-trees before mentioned are used with wide tires, the wheels will pack into the roadbed as they pass over them the loose stones picked up by the horses.

It is the light travel, particularly with one horse, that causes much of the displacement of surface stones in dry times, and there seems to be no way to avoid it. When sprinkling is too expensive a light coat of gravelly sand or clay gravel may be applied with good effect, as it will restore the binding. This should be well rolled to bed the already loose stone. Clay earth should never be used, as it will pick up the stone where wet.

Whenever it is practicable, stone roads should have an earth or gravel roadway on each side of the stone construction, or at least on one side. This was always done in the early construction of macadam turnpike roads in Pennsylvania. They took the name of "summer roads," from the fact that they were preferred for light travel in dry weather and during the summer months. This saves the stone road from much damage by raveling. Roads constructed in this manner are much less expensive to maintain, and it will be found that the extra cost for side roads will be the most economical way to preserve the stone-road construction.

(8) Much of the general repair to stone roads is due to the stone used for surface being of an inferior quality. The sedimentary stones are often used, such as limestone, shale, slate, sandstone, mica schist, and many stratified stones. Some of these kinds of stone will dissolve when exposed to rain water followed by heat, and some are disrupted by frost because they absorb water. Whenever it is possible, none other than igneous or volcanic stone should be used for surfacing. The sedimentary stone above mentioned and others of like kind can be used in the foundation, but the surface stone should be hard and tough. It should wear smooth and not be liable to crush. What is now generally known as trap rock is to be preferred when it can be obtained.

Limestone is found generally throughout this country. The harder kind of limestone, that which contains much silica or crystallized matter, is the best. The soft limestone should not be used, as it soon grinds into dust or dissolves by action of water and air. Whatever kind of stone is used should be as far as possible of a uniform character. It is the hard and soft stones placed on the surface together that cause roughness and holes.

(9) The material for the road may all be of the proper kind, but if this material is not put together properly the road will be expensive to maintain. The material should be put on in layers and thoroughly compacted by repeated rolling of each course, so that when finished it will be impervious to water.

A stone road properly constructed will not soften after rains or be disturbed by freezing. The water will be cast off at right angles to the centre of the road to the side ditches, and the road surface will only need repairing where the stone wears away legitimately under the wheels of the wagons and the horses' feet. Maintenance solely from these causes will not be found costly.

(10) The road surface should be kept clean. A road surface dirty from wear and from dirt brought on by wheels from clay

roads or from leaves or trash of any kind, which are allowed to remain on the surface, soon begins to wear and to be in need of repair. The dust from wear is often blown off, but may be found in considerable quantities in sheltered places. If allowed to remain, rain turns it into mud, and the stone bed will be softened and ruts and ditches formed. It will be found economical to have all surplus dirt removed. It does not cost much if attended to promptly. The dry dust can be removed by sweeping, and the dirt and mud by scraping with hoes. Such material is so mixed with droppings of horses that it contains considerable fertilizing matter and can frequently be sold for enough to pay for sweeping, scraping, and removal. A clean road is not only important, economically considered, but it adds greatly to the comfort of those who use the road. Roads are constructed and maintained for the comfort as well as the pecuniary benefit of those who use them.

Wind tends to remove the dust from the surface, and from between the stones, which, if left there in not too excessive amounts, protects the stone from traffic and does not inconvenience travellers.

Rain in excess removes the binder or softens it, so that it loses its function of bonding the stones together.

Frost heaves the road, causes cracks, and produces mud when leaving the ground.

Horses' hoofs and wagon wheels both abrade and break the stone. This action is very much more pronounced where the binder permits the stones to move, as they then roll one upon the other, causing wear, or become loose and are crushed on the surface. To resist this a hard and tough stone must be selected with an excellent binder.

Horses' hoofs tend to loosen the pavement materially by picking up or displacing the stones, particularly on steep grades.

One of the chief sources of trouble is "ravelling," *i.e.*, the loosening of the stones, and the consequent scattering of the

loose fragments over the surface. On lightly travelled ways this ravelling is more likely to occur than on roads with heavy traffic. Various expedients have been adopted, but "the only remedy which gives any degree of satisfaction is to sprinkle sand over the surface as often as needed. This coating of sand is only a small fraction of an inch in thickness and spread over a width of about eight feet in the centre of the roadway." Roads that are exposed to the action of the wind may require such treatment several times a year.

Water is also sometimes used, or a surfacing of gravel or fine stone may be applied.

To remedy ruts or depressions, heaps of stone should be kept at the roadside for immediate application. Ruts, next to ravelling, require more attention than any other factor in maintenance. These may be caused by heavy loads, narrow tires, tracking, etc., but should be corrected by filling in with new material, rather finer than the original and containing an excess of good binder.

It is not considered a good plan to coat a long length of road with material at once, because, if this is done, vehicles avoid going over the macadam, and thus prevent it from consolidating quickly. If short lengths only of the road are put under repair, the drivers find it more troublesome to be constantly avoiding them than to keep straight on their course, and thus the material is made to bind much sooner.

After April and in summer, or the dry months of the year, all loose stones should be removed from the road, for, if allowed to remain, wheels passing over them loosen the material on which those stones rest, and thus cause much damage to the surface of the road.

The proper maintenance of a road consists in keeping the surface always smooth for traffic and in taking care that the thickness of the macadam is not unduly diminished by wear. A road may be smooth on the surface, but, if the material is

nearly worn away, it cannot be considered to have been properly maintained. To keep a road in an efficient manner unceasing vigilance is required. Ruts and hollows should be at once filled in with macadam, and all weak places as soon as observed treated similarly.

A common fault is to put too great a thickness of stone down at once. Penfold says:

“It is one of the greatest mistakes in roadmaking that can be committed to lay on thick coats of materials, and when understood it will no longer be resorted to. If there be substance enough already in the road, which, indeed, should always be carefully kept up, it will never be right to put on more than a stone's thickness at a time. A cubic yard, nicely prepared and broken to a rod superficial, will be quite enough for a coat, and will be found to last as long as double the quantity put on unprepared and in thick layers. There is no grinding to pieces when so applied; the angles are preserved and the material is out of sight and incorporated in a very little time. Each stone becomes fixed directly and keeps its place, thereby escaping the wear and fretting which occur in the other case.”

For repairs of this nature, where, in fact, the mere surface of the road only is sought to be put in order, no binding material is used or necessary. The wheels of the carriages gradually push the stones into their places, and make them bind with the old material on the road. Some engineers are of opinion that no macadam should be laid down, however thin the coating may be, without the surface of the road being roughened with a pick. There is no doubt that this tends to make the new material bind with the old much sooner, but, on the other hand, it tends to disturb and to weaken the crust if it should be very thin.

For more extensive repairs, *i.e.*, when a road has been allowed to become very thin, and it is necessary that a considerable thickness of material should be laid on, the road must be what Macadam termed “lifted,” or broken with a pick to the depth of two

or three inches, and all large stones must be thrown aside to be broken to the required dimension. A thin layer of new macadam must now be added, and the road rolled. It will usually be found that no binding material will be necessary. When this layer has become consolidated, another, two or three inches thick, should be laid down and again rolled, and so on until the desired thickness of material for the road has been obtained.

Macadam objected to the use of any binding material, such as gravel, sand, chalk, etc., being used with the view to help the macadam to bind, but the almost universal practice now is to sprinkle some such material over the macadam before rolling it.

No road should be lifted unless it has been softened with rain, and there is plenty of water to finish the work of reformation. To lift and remake a road in dry summer weather should not be attempted. The work should be deferred to the later months of the year, but not too late, lest frosts should set in. Some engineers consider October the best month in the year for lifting a road, so that the material may be sifted and sorted when dry, and be consolidated in November and December.

“ No addition of materials is to be brought upon a road unless, in any part of it, it be found that there is not a quantity of clean stone equal to 10 ins. in thickness.

“ The stone already in the road is to be loosened and broken up, so that no piece shall exceed 6 oz. in weight.

“ The road is then to be laid as flat as possible. A rise of 3 ins. from the centre to the side is sufficient for a road 30 ft. wide.

“ The stones when loosened in the road are to be gathered off by means of a strong, heavy rake, with teeth $2\frac{1}{2}$ ins. in length, to the side of the road and there broken, and on no account are stones to be broken on the road.

“ When the great stones have been removed and none left in the road exceeding 6 oz., the road is to be put in shape and a

rake employed to smooth the surface, which will at the same time bring to the surface the remaining stone and will allow the dirt to go down.

“When the road is so prepared, the stone that has been broken by the side of the road is then to be carefully spread over on it. This is rather a nice operation, and the future quality of the road will greatly depend on the manner in which it is performed. The stone must not be laid on in shovelfuls, but scattered over the surface, one shovel following another and spreading over a considerable space.”

A little new macadam, however, mixed with the old, will considerably improve the surface of the road. The old material lifted with a pick, even if broken afresh, never has the sharp edges of new macadam, and much of it is too rounded to bind in the same effective manner as freshly broken stone. Moreover, a great portion of the old macadam when lifted will be found to consist of material which has been reduced either to dust or to too small a size to be fit for subsequent use. This material ought to be rejected, or, if used, it should only be employed for binding purposes.

The breaking up of winter is usually a very severe period on any road, but it has been the experience in Massachusetts that “a thorough rolling with a steam roller in the spring after the frost has left the ground, but before the subgrade is dry, is one of the best means of keeping a stone road in good condition.”

Patching, which consists in applying thin layers of stone to depressions that have been formed in the roadway, must of necessity be resorted to in the maintenance and repair of stone roads. Such applications are made so as to reestablish the road to its original thickness, and hence the amount of stone coating should vary in depth according to the needs of the road at different points. Where long stretches are to be thus treated the stone should be scattered over only a small section, or sections at a

time, so placed that traffic may not avoid it, but pass over it and thus consolidate the material. Such repairs must always be made with stone rich in binder.

The following are the specifications for stone roads as used in the State of New Jersey.

STANDARD STATE AID SPECIFICATIONS FOR STONE ROADS

FOR A STONE ROAD IN.....COUNTY, NEW
 JERSEY, KNOWN AS.....
 BEGINNING AT.....
 EXTENDING TO.....
 A DISTANCE OF.....FEET OR.....MILES
 STONE.....FEET WIDE.....INCHES DEEP
 EARTH.....FEET WIDE. TOTAL WIDTH.....FEET

WORK TO BE PERFORMED

1. The work to be performed will consist in furnishing all material, tools, machinery, and labor necessary for the efficient and proper grading of roadway, side ditches, and side banks, laying, spreading, and rolling of road metal, and leaving the roadway complete in every manner ready for immediate use.

PLANS AND DRAWINGS

2. The plan, profile, and cross-sections on file in the office of the State Commissioner of Public Roads and at the office of.....County Engineer.....New Jersey, show general location, profile, details, and dimensions. The work will be constructed in all respects according to the above-mentioned plan, profile, and cross-sections, which form part of these specifications.

3. Any variation of location, profile, size, and dimensions from that shown on the plan, as may be required by the exigencies of construction, will, in all cases, be determined by the engineer, but the contractor shall not, on any pretence, save that of the written order of the contracting parties and the State Commissioner of Public Roads, deviate from the intent of the plan or specifications.

4. On all drawings, figure dimensions are to govern in cases of discrepancy between scale and figures.

GRADING

5. Under this head will be included all excavation and embankment required for the formation of the highway, cutting all ditches or drains about or contiguous to the road, removing all fences, walls, buildings, trees, poles, or other encumbrances, the excavation and embankment necessary for reconstructing cross or branch roads or entrances to dwellings in cases where they are destroyed or interfered with in the formation of the roadway, and all other excavations and embankments connected with or incidental to the construction of the said road.

EXCAVATION

6. The roadway to the widths and depths as shown on plans must be excavated or built to the same curvature as that of the surface of the road when finished. The grade, from centre to sides, must be as shown on plans.

7. The earth taken from any cut or ditch shall be deposited where the engineer may direct, either within or without the line of the road, but no earth shall be removed from the line of the road without the order of the engineer.

8. The grading shall be completed for the full width of the road, from gutter to gutter, before any macadamizing is commenced.

EMBANKMENT

9. Material taken from the excavations, except when otherwise directed by the engineer, shall be deposited in the embankments, either on the roadway or sidewalks. Rejected or excess material will be used to increase the width of the embankments or deposited in spoil banks or waste piles, as and where the engineer may direct.

10. When there is not sufficient material in the excavations of the road to form the embankments, the deficiency must be supplied by the contractor from without the road. The character of said material and place of excavation must be approved by the engineer.

11. The embankments will be formed in layers of such depth, generally one (1) foot, and the material deposited and distributed in such a manner as the engineer may direct, the required allowance for settling being added. Each layer shall be carried across the entire width of the embankment and completed before commencing another, and this method shall be followed with each succeeding layer until the established grade is reached.

SLOPES

12. Slopes in both embankment and excavation shall be one and one-half ($1\frac{1}{2}$) horizontal to one (1) vertical, when the width of the road will permit; if the road is too narrow to allow the full slope within its side lines, the engineer shall not calculate the quantities, either in embankment or excavation beyond said side lines, unless the required ground shall be first dedicated to the public in writing by the owner or owners thereof.

WIDTH AND DEPTH

13. The construction to be.....inches deep andfeet wide, as shown on plan and detail sheet.

ROADWAY

Subfoundations.

14. When the excavations and embankments have been brought to a proper depth below the intended surface of the roadway, the cross-section thereof conforming in every respect to the cross-section of the road when finished, the same shall be rolled with a ton roller until it is inches below the intended surface of the road and is approved by the engineer and supervisor. If any depressions form under such rolling, owing to improper material or vegetable matter, the same shall be removed and good earth substituted, and the whole re-rolled until thoroughly solid and to above-mentioned grade. Water must be applied in advance of the roller when, in the opinion of the engineer and supervisor, it is necessary.

STONE CONSTRUCTION

Telford Foundations

15. After the roadbed has been formed and rolled, as above specified, and has passed the inspection of the engineer and supervisor, a bottom course of stone, of an average depth of inches, is to be set by hand as a close, firm pavement, the stones to be placed on their broadest edges lengthwise across the road in such manner as to break joints as much as possible, the breadth of the upper edge not to exceed four (4) inches. The interstices are then to be filled with stone chips, firmly wedged by hand with a hammer, and projecting points broken off. No stone of greater length than ten (10) inches or width of four (4) inches shall be used, except each alternate stone on outer edge, which shall be double the length of the others and well tied into the bed of the road. All stones with a flat, smooth surface must be broken. The whole surface of this pavement must be subjected to a thorough settling or ramming with heavy

sledge-hammers, and thoroughly rolled with a.....ton
roller. No stone larger than two and one-half
 ($2\frac{1}{2}$) inches shall be left loose on top of telford.

MACADAM

First Course of Broken Stone

16. After the roadbed has been formed and rolled, as above specified, and has passed the inspection of the engineer and supervisor, the first layer of broken stone, consisting of two and one-half ($2\frac{1}{2}$) inch stone, or stone that will pass through a ring three (3) inches in diameter, shall be deposited in a uniform layer, having a depth of.....inches, and rolled repeatedly with a.....ton.....roller until compacted to the satisfaction of the engineer and supervisor. No stone in this course shall be less than two (2) inches in length.

17. The depth of loose stone in this and all other courses must be measured by blocks the required thickness of the said loose stone. These blocks must be placed at frequent intervals amid the loose stone when being spread.

BINDER BETWEEN FIRST AND SECOND COURSE FOR TEL- FORD OR MACADAM

18. On the first course of stone a quantity of.....
 binder shall be spread in a uniform layer, and the whole rolled until the stones cease to sink or creep in front of the roller. The quantity and quality of this and all other binding shall be subject to the approval of the engineer and supervisor. Water must be applied in advance of the roller, if ordered by the engineer or supervisor.

SECOND COURSE OF BROKEN STONE FOR MACADAM OR TELFORD

19. The second course of broken stone shall consist of one and one-half ($1\frac{1}{2}$) inch stone; that is, every piece of stone shall

be broken so that it can be passed through a ring two (2) inches in diameter, and no stone shall be more than two (2) inches or less than one (1) inch long. This course shall be spread in a uniform layer inches in depth and rolled until thoroughly settled into place to the satisfaction of the engineer and supervisor. Water must be applied as ordered by the engineer or supervisor.

BINDER ON SECOND COURSE OF STONE

20. Binder on this course of stone must be applied in the same manner as binder on first course of stone (see Art. 18), as directed by engineer and supervisor.

SURFACE

21. When the two courses are rolled to the satisfaction of the engineer and supervisor, a coat of fifty (50) per cent of three-quarter ($\frac{3}{4}$) inch stone and fifty (50) per cent of screenings, properly mixed, is to be spread of sufficient thickness to make a smooth and uniform surface to the road, then again rolled until the road becomes thoroughly consolidated, hard and smooth.

22. Rolling must be done by the contractor with a ton roller, approved by the engineer.

23. Any depressions formed during the rolling, or from any other cause, are to be filled with one and one-half ($1\frac{1}{2}$) inch stone, or three-quarter ($\frac{3}{4}$) inch stone, or both, and screenings, approved by the engineer, and the roadway brought to the proper grade and curvature as determined by him.

24. Water must be applied in such quantities and in such manner as directed by the engineer or supervisor.

MANNER OF ROLLING

25. In the rolling the roller must start from the side lines of the stone bed and work toward the centre, unless otherwise

directed. The roller shall at all times be subject to the directions of the engineer and supervisor, who may, from time to time, direct such methods of procedure as in their opinion the necessities of the case may require.

QUALITY OF MATERIAL

26. All stones must be as nearly cubical as possible, broken with the most approved modern stone-crushing machinery, free from all screenings, earth, and other objectionable substances, of uniform size, and the same kind and quality, or equally as good in every particular as that shown in the engineer's office. The one and one-half ($1\frac{1}{2}$) inch stone, three-quarter ($\frac{3}{4}$) inch and screenings for binder and final finish must be of the best trap-rock, free from loam or clay.

27. The contractor must furnish samples to the engineer of the kind of stone to be used in the work before the opening of the bids, and to the State Commissioner of Public Roads before the approval of the contract by him.

ENTRANCES TO DWELLINGS

28. All driveways leading to dwellings along the road shall be macadamized with the second course and finished in the same manner as prescribed for the main road. The macadamizing shall be carried to a distance of not more than six feet beyond the gutter line of the road, as indicated by the engineer's stakes, but in no case shall the macadamizing be carried beyond the side line of the road as indicated by the fences.

SHOULDERING

29. A shoulder of firm earth or gravel is to be left or made on each side, extending at the same grade and curvature of road to side ditches or gutters. This shoulder is to be rolled according to the directions of the engineer.

COBBLE GUTTERS

30. Cobble gutters shall be laid from station number to station number The cobbles used must be good, hard, sound stone. Medium-sized stone, not over five-inch face on its longest diameter, must be used, except for centres or sides, where eight-inch cobbles may be used. The cobbles must be bedded in not less than six inches of good, sharp sand or gravel, and laid with the longest diameter of stone parallel with the road, and thoroughly rammed into shape and place. All stone broken in ramming must be removed and replaced with perfect stone.

SIDE DITCHES OR GUTTERS

31. The side ditches or gutters are to be excavated as per stakes furnished by engineer, in order to give an easy flow of water, so that no water shall be left standing on the road or in the ditches, for which no extra payment will be made.

UNDERDRAINS

32. Underdrains, if found necessary, shall be constructed by the contractor of good inch tile, laid upon a board of not less than one (1) inch in thickness and six (6) inches in width. The top of the tile shall be at least inches deep, unless otherwise directed by the engineer, the joints shall be covered with salt hay, or material equally as good, and the trench filled with pervious earth. These drains must be constructed whenever and wherever the engineer and supervisor shall decide.

33. When directed by the engineer, a stone drain may be used in place of the tile drain. A trench one foot wide and one foot six inches deep shall be excavated below the subgrade, said excavation to be filled with loose broken stone to a depth required by the engineer.

BROAD-TIRE WAGONS

34. All wagons and carts used during the construction for hauling stone, earth, or any other material must have tires not less than three and one-half ($3\frac{1}{2}$) inches in width.

NO EXTRA PRICE

35. No allowance in measure of depth of pavement will be made on account of any material which may be driven into the roadbed by rolling. The pavement, when completed, must conform to the grade and the cross-sections, and be satisfactory to the engineer and State Commissioner of Public Roads, whose decisions shall be final.

36. No extra work will be paid for unless the price has been agreed upon between the contracting parties, including the State Commissioner of Public Roads, and indorsed upon the agreement witnessed by the engineer.

37. All clay or gravel for shouldering or binder and all extra hauling is to be done at the contractor's expense.

BIDS

38. Bids will only be received under these specifications for the road complete. The prices per yard for excavation, telford, macadam, etc., are intended for the use of the engineer in making estimate to the Board of Chosen Freeholders of work done. No bid will be received in which all of the following items are not filled out:

(1) Price per cubic yard for earth excavations, without classification, as per cross-sections throughout the length and width of the road.

(2) Price per cubic yard for any necessary earth excavations and removing material without classification and measured in excavation, not included in the length and width of the road.

(3) Price per square yard for macadam driveways to dwellings.

(4) Price per square yard for telford road complete.

(5) Price per square yard for macadam road complete.

(6) Price per square yard for cobble gutters complete.

(7) Price per lineal foot for underdrains, furnishing all labor and material.

(8) Price (lump) for the whole road complete, according to above specifications and plans.

ESTIMATE OF QUANTITIES

39. (1) Excavation, earthcubic yards.

(2) Extra excavationcubic yards.

(3) Macadam drivewayssquare yards, as specified.

(4) Telfordsquare yards, as specified.

(5) Macadamsquare yards, as specified.

(6) Cobble gutterssquare yards, as specified.

(7) Underdrainslineal feet.

(8)

40. These quantities are the result of calculation, but are to be considered as approximate. The county will not be responsible for any excess in above quantities, should any occur. The contractor is expected to satisfy himself as to the nature, character, and quantity of the labor and material required by a personal examination of the work contemplated.

CHECK ACCOMPANYING BIDS

41. Bids shall be accompanied with a certified check, payable to the order of the Director of the Board of Chosen Freeholders, in the sum of one thousand dollars (\$1,000), as a guaranty that if the contract shall be awarded to him he will, when required by said board, execute an agreement in writing to perform the work according to the specifications. Upon failure by the contractor to enter into said agreement with the said Board of Chosen Free-

holders, said certified check shall be forfeited and considered as liquidated damages.

LIABILITIES OF CONTRACTOR

42. He shall maintain sufficient guards by day and night to prevent accidents from travel, and will be liable for any damage which may arise from his neglect to do so, or from any omission on his part.

43. He shall keep the road sprinkled until the certificate of completion by the engineer is given.

44. He is to commence and prosecute the work upon the road at the end farthest from the source of supply of broken stone, unless otherwise ordered by the engineer, within days from and after the signing of the contract, and shall continue work thereon until completion, except as herein provided.

45. He further agrees to complete the same on or before the day of A.D. Twenty dollars for each day that the work shall remain uncompleted, after the time allowed by contract, may be deducted, as liquidated damages, from any moneys due the contractor, unless otherwise agreed upon by the Board of Chosen Freeholders, after presentation of certificate of the engineer recommending the extension of the time limit of completion.

46. The contractor shall keep the finished roadway, earthwork, side ditches, and underdrains in repair for the period of one year from the date of its completion and acceptance, and, in addition thereto, for as much longer as for any period or periods during said year it shall be out of proper condition. If, during that time, the roadway or any part of the work shall, in the judgment of the engineer and the Board of Chosen Freeholders, require repairing, and they shall duly notify the contractor to make such repairs as required, and the contractor should refuse or neglect to do so to the satisfaction of the said engineer and the Board of Chosen Freeholders, within five days from the date of

service of notice, then the said engineer and the Board of Chosen Freeholders shall have the right to have the work done properly by other parties and recover the cost for the same from the said contractor or his surety.

47. The contractor will be required to preserve all stakes and bench-marks made and established on the line of work until duly authorized by the engineer to remove the same. All stakes or bench-marks disturbed or removed by the contractor or his agents without the permission of the engineer shall be replaced at the expense of the contractor.

48. The contractor shall not disturb the position of title-stones (the corners of properties adjacent to the road), but where they appear he will either lift or lower them, under the personal supervision of the engineer.

49. The contractor must also preserve the roadway on which he is working from needless obstruction, and where necessary he must construct safe and commodious crossings, to be maintained in good order. He shall afford all proper and reasonable means for the accommodation of the public, and leave the roadway complete in every manner ready for immediate use.

50. All loss or damage arising from the nature of the work to be done, or from any unforeseen or unusual obstruction or difficulty which may be encountered in the prosecution of said work, or from the action of the elements, shall be sustained by the contractor.

PROVISION FOR DRAINAGE

51. If it is necessary in the prosecution of the work to interrupt or obstruct the natural drainage of the surface, or the flow of artificial drains, the contractor shall provide for the same, during the progress of the work, in such a way that no damage shall result to either public or private interest. He shall be held liable for all damages which may result from any neglect to provide for

either natural or artificial drainage, which he may have interrupted.

RIGHT TO BUILD BRIDGES, CULVERTS, ETC., AND SUSPENSION OF WORK

52. The right of the county to build bridges, culverts, lay pipes or other appurtenances in said road during the progress of the work, is expressly reserved, as well as suspending the work, or any part thereof, during the construction of the same, for the purposes above stated, without further compensation to the contractor for such suspension than an extension of time for completing the work as much as it may have been delayed.

STOPPING WORK ON ACCOUNT OF WEATHER

53. The State Commissioner of Public Roads, engineer, or supervisor may stop any portion of the work, if, in their judgment, the weather is such as to prevent the same being done properly. No allowance of any kind will be made for such stoppage, except an extension of the time for the completion of the work as herein provided.

ABANDONMENT OF CONTRACT

54. If at any time the work under contract should be abandoned, or if at any time the engineer should judge and so certify in writing that said work, or any part thereof, is unnecessarily delayed, or that the contractor is wilfully violating any of the conditions or covenants of this contract, or is executing the same in bad faith, then, in that case, the Board of Chosen Freeholders shall notify the said contractor to discontinue all work under this contract. They may employ other parties to complete the work in such manner as they may decide, and use such material as may be procured upon the line of aforesaid work, and, if necessary, procure other material for its completion, and charge the expense of the said labor and material to the contractor, which

expense shall be deducted from any moneys due him under contract. In case these expenses shall exceed the sum which would have been payable under contract, if the same had been completed by said contractor, he or his bondsmen shall pay the amount of the excess to the Board of Chosen Freeholders, on notice from the engineer.

ENGINEER

55. The engineer shall be selected or appointed by the Board of Chosen Freeholders and paid by it. He shall furnish all surveys, profiles, plans, specifications, and estimates of quantities of all kinds before specifications are signed, and in such a clear manner that lump bids can be made upon the work. He shall furnish all lines and grades required for the completion of the work. He shall furnish estimates for quantities of work done before partial payments can be made, the quantity of road laid being determined by surface measurements. Should any difference arise between the contracting parties as to the meaning or intent of these specifications, his decisions on these matters are to be final and conclusive. The work is to be done according to his directions, and if any material of which he does not approve is brought upon the road, it is to be removed at the expense of the contractor. If the contractor fails or neglects to do any part of the work as specified or as directed by the engineer, then, in that case, all other work shall be discontinued, on notice from the engineer to the contractor, or to the superintendent or foreman in charge of the work for the contractor, until such time as the work complained of has been done to the satisfaction of the engineer, and the contractor will not be entitled to or allowed any compensation or extension of time for such discontinuation or suspension of the work.

SUPERVISOR

56. Nothing in these specifications relating to the duties of the engineer shall be taken or construed in any manner to conflict

with the duties of the supervisor, as specifically set forth in the act entitled "An act to provide for the permanent improvement of public roads in this State," approved March 27th, 1905, but they shall coöperate as far as practicable.

INCOMPETENT WORKMEN

57. The contractor shall employ competent men to do the work, and whenever the engineer and supervisor shall inform him, or his representative in charge, in writing, that any man on the work is unfitted for the place, or is working contrary to the provisions of the specifications or the instructions of the engineer and supervisor, he shall thereupon be discharged.

INSPECTION

58. All directions and determinations necessary to give due and full effect to any of the provisions of these specifications shall be given by the engineer and supervisor.

59. All material and workmanship of any kind shall be subject at all times to the inspection of the engineer and supervisor. Whenever unfaithful and imperfect work is discovered, it shall be immediately repaired or replaced by the contractor, after due notification from the engineer and supervisor.

SUBLETTING OF CONTRACT

60. The contractor shall not assign or sublet any portion of this contract without the consent of the Board of Chosen Freeholders and the State Commissioner of Public Roads.

PAYMENTS

61. monthly payments will be made by the Board of Chosen Freeholders to the contractor for work performed, upon presentation by him of the proper certificates of the engineer and supervisor, in a sum not to exceed eighty per cent of the amount then due, together with releases from all liens, if required. Fif-

teen per cent will be paid at the completion of the work and the acceptance of the same in writing by the Board of Chosen Freeholders and the State Commissioner of Public Roads. The remainder, or five per cent, will be retained by the Board of Chosen Freeholders for a period of one year as security for the faithful performance of Article 46.

BOND OF CONTRACTOR

62. The contractor will be required to execute, within thirty days of giving of contract, a bond in such sum and with such securities as shall be approved by the Board of Chosen Freeholders, conditioned for the faithful performance of the contract, to indemnify and save harmless the Board of Chosen Freeholders from all suits or actions of any name or description brought against them on account of any act or omission of the contractor or his agents, and for the faithful performance of the contract by the contractor. Said bond shall be in a sum of not less than the estimated cost of the road when completed. Any change made in the plans, specifications, agreements, or quantities without the consent of the bondsmen shall in no way vitiate said bond. The contractor hereby further agrees that so much of the money due him, under and by virtue of this agreement, as shall be considered necessary by the Board of Chosen Freeholders, may be retained by them until all such suits or claims for damages aforesaid shall have been settled, and evidence to that effect furnished to the satisfaction of the Board of Chosen Freeholders.

CONTRACTOR TO INSURE PAYMENT FOR LABOR, MATERIAL, ETC., ON FINAL ESTIMATE

63. The contractor must also furnish the engineer with satisfactory evidence that all persons who did work, or furnished material for this contract, or who have sustained damage or injury by reason of any act, omission, or carelessness on his part or his agents in the prosecution of the work, have been duly paid

or secured. He shall also give notice to the engineer within ten days after the completion of the work, and before final estimate is made that any balance for such work or materials, or compensation for such damages due, has been fully paid or released.

64. The right is reserved to reject any or all bids, if deemed to the interest of the county or State.

.....
County Engineer.

Approved this....., A.D....., by resolution of the Board of Chosen Freeholders of the county of.....

.....
Director of Board of Chosen Freeholders.

.....
Clerk of Board of Chosen Freeholders.

OFFICE STATE COMMISSIONER OF PUBLIC ROADS, TRENTON, N. J.

I have this day carefully read and examined the foregoing specifications, and the same are hereby approved.

Any departure from these specifications must have the written consent of the State Commissioner of Public Roads.

Given under my hand, this....., A.D. 190

.....
State Commissioner of Public Roads.

CHAPTER V

MISCELLANEOUS ROADS

BURNT-CLAY ROADS

IN the Mississippi valley, where road material is not only scarce but expensive, recourse has been had to burning the clay, of which the roads are in a great measure formed, to produce a harder and better surfacing. During the dry season, when there is but little moisture in the soil, the material is cut from the roadway in blocks to the depth of about 2 ft. and piled so as to form an enclosure 8 to 10 ft. sq. After this has thoroughly dried out, brush and wood are placed inside, more clay is placed on top to completely enclose it, and the burning of the clay begun. The hardened material resulting from this burning is broken up into small fragments and used as a covering to the roadway. In the wet season, when the roadway would be particularly soft, it is very satisfactory in that it keeps the vehicles from breaking through to the less solid material below.

CORDUROY ROADS

A corduroy or log road derives its name from the fact that in appearance it closely resembles the material of that name, consisting as it does of a succession of ridges and hollows. These roads are designed to carry traffic over naturally wet and soft ground, such as swamps and marshes, where drainage is either impossible or prohibitive because of cost. They are formed by placing logs side by side, with the length perpendicular to the axis of the road, upon a roughly prepared foundation of the natural soil. Sometimes the logs are held in place by longitudinal stringers being spiked to the ends, sometimes the spaces are

filled with smaller poles to make a more even surface, and sometimes upon the timber is placed sod or earth to reduce the tractive resistances. Crude as these roads are, in sparsely settled districts they often furnish the only solution of keeping a road open, particularly in the wet season.

OILED ROADS

The first application of oil to a road surface was made as an experiment in 1898, in Los Angeles County, Cal., for the purpose



FIG. 49.—Road Through Deep Sand.

of determining whether or not oil possessed properties that would cause it to lay dust. With that object in view it has since been employed quite successfully on many miles of road in California, and experimentally in New Jersey, Massachusetts, Pennsylvania, Indiana, Colorado, and the District of Columbia; and in foreign countries, in England, France, and Switzerland.

The only object in the first experiments was to determine if oil would lay the dust, which the results quite conclusively proved; but other and greater advantages besides this have since been discovered by its continued use. The deep seal brown color produced by it is very restful to the eye, but more particularly it acts as a binder of the loose particles of dust and stone on the road surface, forming a sort of tough and hard crust somewhat similar to asphalt. When the crust is thin it has been observed



FIG. 50.—Same Road, after Oiling, Has a Hard Smooth Crust.

that the wheels quickly cut into it, especially in wet weather; but experience has taught that with the oil sinking to a depth of three inches or more, this is prevented.

Rains seem to have no effect upon such roads, for the surface is impervious; and in California, where the storms are frequently torrential in character, they have been found to with-

stand them almost without a sign of deterioration. Unlike asphalt pavements, which during hot weather show the effect of heat by softening, oiled roads remain as hard and firm as in cold weather.

All petroleums will lay the dust, but oils with an asphalt base are found to be best suited to the purpose, not only because they prevent the dust nuisance, but because the asphalt in them acts as a most excellent binder of the small particles which lie on the

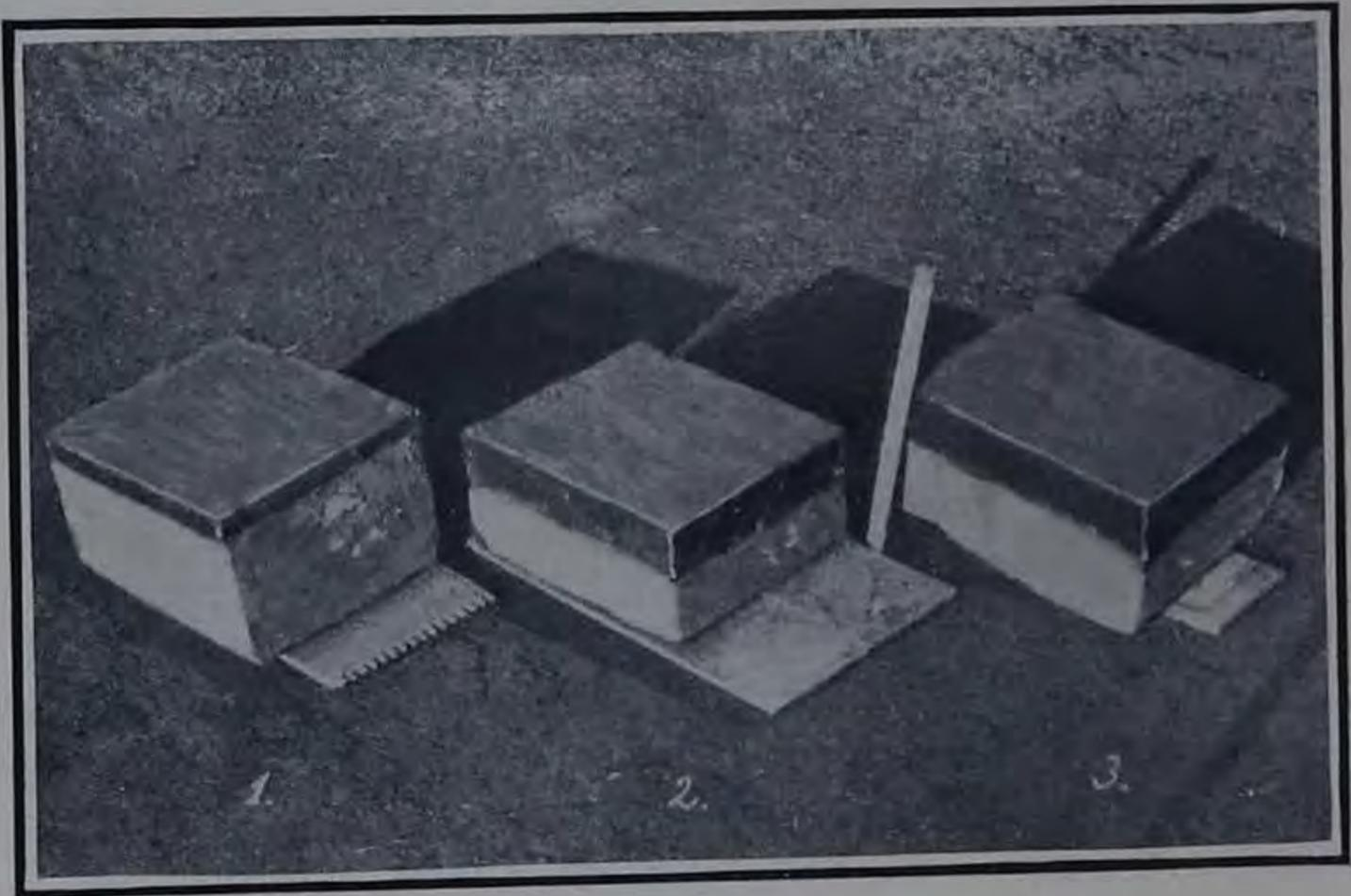

FIG. 51.—Sections of Oiled Crusts from Three Oiled Roads.

surface and go to form the crust. For this reason the higher the percentage of asphaltum in the oil the better.

Previously it was considered good practice to apply the oil when the surface was moist, but experience has taught that the road should be perfectly dry to secure the best results. Heating also is not now considered necessary. It is true that when the oil is heated the ground absorbs it more quickly, but the expense attached to this operation hardly warrants the outlay.

Before the oil is applied the road bed should be graded, given a crown of about one-half inch per foot, sprinkled with water, rolled with a light roller to secure a uniform consistency in the ground and a consequent uniform absorption of oil, and then allowed to dry out thoroughly. After this a toothed harrow, the teeth of which are three inches long, should be drawn over the surface to break it up, so that when the oil is applied it will readily combine to form a crust of this thickness.

If the surfacing material is too hard, as in macadam pavements, to permit of this, then a layer of sand, earth, or gravel must be laid about three inches deep, and the oil sprinkled over this. During the application and until the soil has thoroughly absorbed the oil, all traffic is prohibited from the use of the roadway. The oil is spread by a specially constructed tank cart, such as shown in the figure.

Without any preparation whatever the oil is often applied to a road, but the results are not nearly so satisfactory. Particular care should be taken on improved roads to remove all loose material on the surface, so that the oil will reach the body of the road, and not merely lie on the surface in the form of an oily mud to be easily scattered by the wheels of vehicles.

" In what is known as the De Camp machine the distributor is mounted on separate wheels and coupled to the rear of the tank wagon, the slip tongue being removed. The oil runs from the tank through a flexible hose. It has an oil reservoir and three sets of fingers. The first set makes furrows just ahead of the oil-discharging pipes. The second set of fingers (or curved teeth) covers up the oil, and a third set stirs up the combination of oil and dirt. There is also a drag to crush any globules or chunks which may tend to form. When oil is being distributed the second and third sets of fingers and the drag are raised from the ground by hooks. After the oil is distributed this machine is detached from the tank, the slip tongue put in, and the machine

dragged back and forth over the oiled road until the oil has been thoroughly incorporated with the road material."

After from twenty-four to forty-eight hours the road may be thrown open to traffic, but during that period horses and wagons should be positively prohibited from the street.

In macadam pavements, where the surface is hard, the oil is

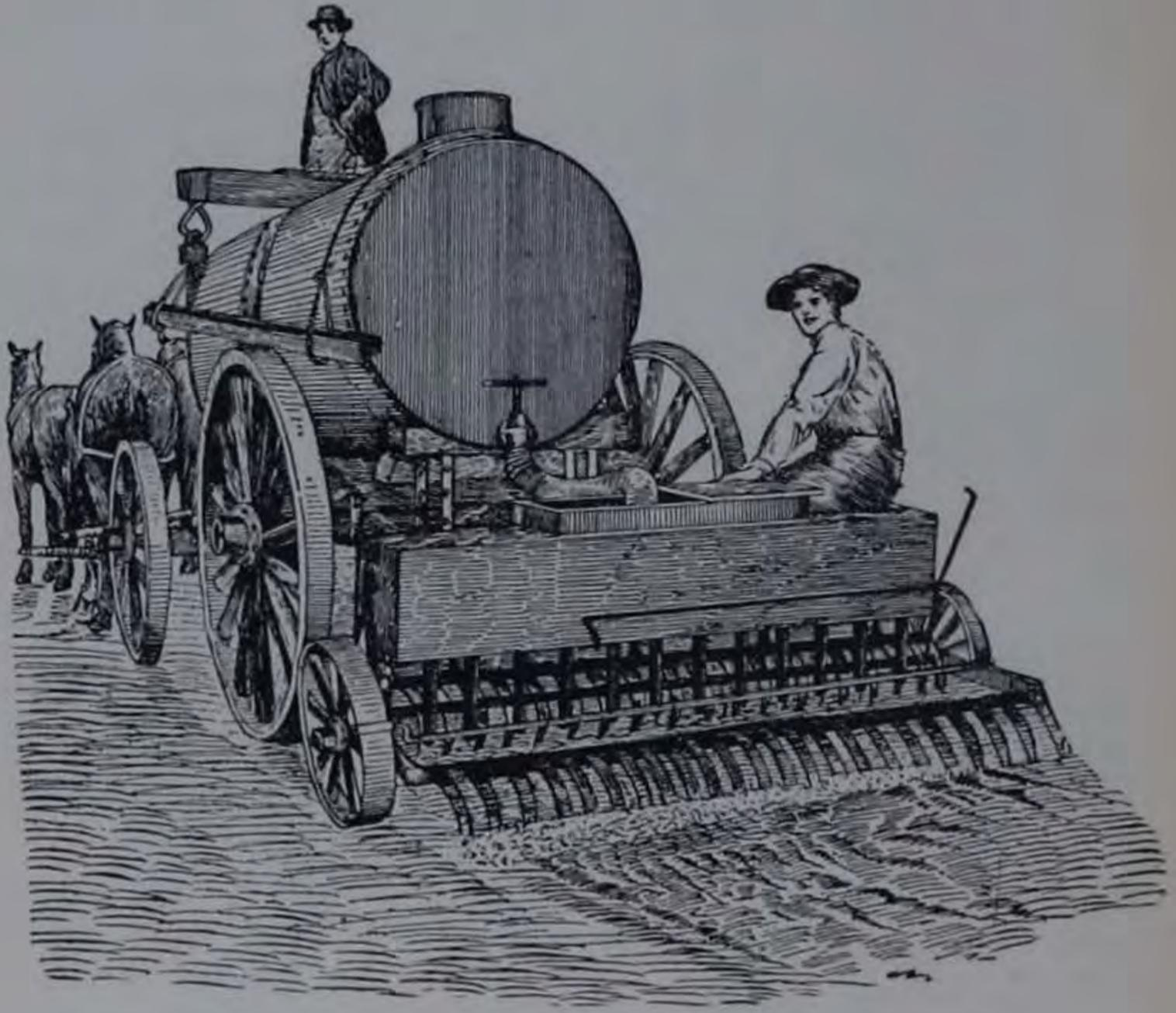

FIG. 52.—Road Oiler.

put on hot, so that some may readily sink into the pavement while that which is left is sprinkled and incorporated with sand which forms a hard, even crust on the macadam and gives excellent results in that it produces an impervious covering and at the same time protects the stone from wear.

The quantity of oil required for a 16 ft. roadway will vary from 250 to 400 bbls. of 42 gals., per mile, depending upon the thickness of the crust, the porosity of the soil, and the percentage of asphaltum in the oil. The number of applications depends upon the porosity of the oil.

Repairs are made by preparing a sort of mortar of oil and sand, and filling the depressions or holes with this, after which it is well rammed.

“ It frequently happens that travel follows the same track, and the narrow tires and feet of the horses wear depressions. It is important to correct these and reshape the road at least once a year. It has been found that an ordinary blade road grader will not do this successfully, but will tear up the oiled crust and destroy it. The White smoother is a device for shaving off elevations and filling up depressions in an oiled crust. It consists of a pair of runners 16 ft. long and 4 ft. apart. Between them, at the front end, are set on a slant backward obliquely to the left, 3 rows of $\frac{3}{4}$ in. steel harrow teeth, so adjusted that they shave along lines just 1 in. apart. As their edges get dull, the teeth can receive a quarter or half turn, and their height from the ground can be regulated. There is also a blade set obliquely which scrapes off the shavings made by the harrow teeth. These shavings, confined by the two runners and the blade, naturally seek the depressions. In the left-hand runner is an opening, through which any surplus shavings are forced out toward the centre of the road, thus tending to raise the crown. There are wheels on the sides upon which the machine, with runners raised from the ground, travels when being moved from one place to another, and a steering gear by means of which the operator readily controls its direction. A road reshaped with this machine, treated with a light sprinkling of oil and a thin sheet of sand, and rolled, resembles a city asphalt street when first laid.”

SHELL ROADS

In the Chesapeake-Bay district, where oysters are so plentiful and road material somewhat scarce, it has been found that the shells serve quite satisfactorily as a road metal. The shells are easily crushed by traffic and, possessing an extremely high cementation factor due to the lime, readily bind together to form a roadway of more than ordinary value. The disadvantage of such roads is that the material being so soft, is quickly ground to powder, which the wind or the rain readily carries away.

In Maryland as many as 250 miles of these roads have been built at a very reasonable figure. Where the shells are plentiful they will average $1\frac{1}{2}$ cts. a bushel, and a road 15 ft. wide will require about 45,000 bushels per mile.

“As with any road, before applying the surfacing, the roadbed for the shell road should be first graded and given the proper cross-section. If there is a wet springy soil, drains should also be provided. Before the shells are put on, the roadbed should be rolled firm and hard. If over a stiff clay soil which becomes sticky in wet weather and holds moisture, a layer of three or four inches of sand should be first spread on the clay road. Shells may then be spread, sprinkled with sand, and rolled with a light roller. Experience has shown that the shell roads constructed over a clay soil have broken through more easily than those over a sandy soil. This is the result of non-drainage of the water which is held in the clay. To assist in compacting the shells, as in the construction of a stone road, a shoulder of earth should be formed at the sides to prevent the shells from spreading.” When compacted, the road forms an impervious covering, and would answer well as a foundation for a thin layer of stone.

SLAG ROADS

Slag roads need but little mention since they are used only to a limited degree, and then only in the vicinity of smelting

plants where it may be desirable to dispose of such material. Slag usually contains a large percentage of silica, thus making a road surface built of it extremely hard, but frequently it lacks in binding properties. Slags running high in lime, however, possess this characteristic and produce a very satisfactory hard and smooth surface. The dust, also, seems to act like a cement, binding the fragments together and growing harder and harder.

SHALE ROADS

The argillaceous shales are unsuited for road-building purposes, as they quickly grind to powder and are turned to mud by the action of the atmosphere and rain, but in the State of New York the arenaceous shales, possessing some of the qualities of soft sandstone, have in cases been the means of affording a cheap and satisfactory roadway.

The material is obtained close at hand and, after the roadway has been graded properly, from 8 to 10 ins. is spread and compacted by rolling with a 10 ton roller. The interstices are filled with gravel, a thin layer of it spread over the surface, and the road is then sprinkled and rolled again.

COAL-SLACK ROADS

Coal slack is the fine material resulting from the handling of coal and the disintegration of soft coal. It is commonly used in coal-mining sections for road purposes where it is often a problem to dispose of it.

As the material is easily ground to a powder and blown away, it is better suited to light, rather than heavy traffic.

CHARCOAL ROADS

Charcoal roads are only built in the lumber districts where timber is both cheap and plentiful. They are constructed as follows: the trees are felled and the trunks piled lengthwise along

the centre of the road to the height of about 6 ft., being 9 ft. wide at the base and 2 at the top. The timber is then completely covered over with straw, earth, or sod, and the wood burned. When completely charred, the covering is removed and the charcoal spread over the road surface to a depth of about two feet at the centre and one foot at the side. It is claimed that such roads are remarkably free from mud and dust. For the sections they are intended to serve such roads would seem to fill most of the requirements, and cost about one-quarter that of a good stone or gravel road.

PLANK ROADS

These roads are generally constructed of a width of 8 ft., as with wider ones the traffic tends to follow the middle of the road and hence produce undue wear. If 8 ft. is not sufficient, 16 ft. may be used, but in this case there should be two separate lines rather than one. This may be secured by spiking down a 6×6 stringer in the centre of the road parallel to the axis, with spaces for turnouts every 100 ft.

The planks, 8 ft. long, 9 to 12 ins. wide, and 3 to 4 ins. thick, are laid perpendicular to the line of traffic upon sills which are firmly bedded upon an even foundation of the natural soil. These sills consist of planks 15 to 20 ft. long, 12 ins. wide, and 4 ins. thick, laid flat, placed parallel to the axis of the road, and spaced 4 to 5 ft. centre to centre so that the wheels will be directly over the stringers. They should break joints to prevent the soil at these points from sinking.

The ends of the plank are not arranged in a straight line, but every third or fourth is offset a few inches to form a shoulder and permit teams to turn on or off the planked way.

Sometimes the planks are spiked down, but this is not essential if they rest upon a good even, firm, and dry foundation of natural soil between the sills. Occasionally earth or gravel will be spread over the planks to prevent their too rapid wear, and

also form a firmer covering as grit is forced into the fibres and makes the road hard.

Where a plank road exists beside one of dirt, drainage is secured by sloping them in opposite directions, the former at a grade of 1 in 32, and the latter 1 in 16. If such dirt roads are not provided, then turnouts must be constructed at intervals. These places have a wooden trackway, 16 ft. in width, with the planks laid on 4 instead of 2 stringers, to which they are spiked.

The advantages of such roads are that they reduce the tractive force by about one-third that required on a dirt road, and at all seasons of the year afford a good highway.

TRACKWAYS

In the United States trackways, whether of stone or steel, seem to be less popular than abroad, for in a number of towns in northern Italy such means of transporting heavy loads is quite common, while similar roads are made use of in the cities of London, Manchester, and Liverpool, England. In Spain a steel trackway 2 miles long was constructed at a cost of \$28,518 some years ago, about 1890, which seems to have given eminent satisfaction. This road, joining the towns of Grao and Valencia, had a daily traffic of 3,200 vehicles, and yet the yearly repairs after 7 years' service cost but \$380, while previous to this the cost was \$5,470 per annum.

The older forms of trackway consist of blocks of stone varying in dimensions, but usually from one to two feet wide, placed in lines parallel to the axis of the road, and at a distance apart equal to the tread of the wagon. Between these lines of track a cobble or broken-stone pavement is laid to furnish a foothold for the horses, and with this combination of easy traction and good foothold the hauling of very heavy loads is quite possible. The cost of such wheelways is high, but frequently they are less expensive to put in to a short piece of road on a steep grade

to reduce the tractive force, than it would be to cut down the existing grade by excavation. At less than half the cost that would have been needed to reduce a grade from 1 in 20 to 1 in 34, Telford on the Holyhead road produced the same result by introducing stone wheelways.

A cobble or stone pavement is placed for some distance adjacent to the tracks to give them a solid foundation and prevent too great wear on the trackway and road by the turning on or off of teams.

Judson in his book on "City Roads and Pavements" mentions a stone-block trackway that was built on the Albany and Schenectady Turnpike in 1833, and parts of which are still in existence.

"The 'stone rails' were made 4 ins. thick and were roughly cut 18 to 24 ins. wide of any length from 2 to 8 ft. with square ends to be laid close together and with both faces flat to permit of turning over when worn. . . . They were bedded in the gravel and broken stone of the roadway." Between the track and on each side to a distance of 5 ft. was a cobble pavement.

In 1901 about 2,000 ft. of steel double trackway was laid in Chicago, Ill., but, failing to give satisfaction, was removed. In 1902 a steel wheelway designed by General Roy Stone of the Office of Road Inquiry of the Department of Agriculture was laid in Murray Street, New York City, but this, too, proved unsatisfactory, as horses were unable to secure a foothold. It has since been removed.

SAND-CLAY AND BURNT-CLAY ROADS

Natural sand-clay roads may frequently be formed in localities where the soil contains the right proportions of sand and clay. Where the prevailing subsoil is of clay, or on the other hand of sand, the two, if properly mixed, may succeed in overcoming the objections of each. This is particularly important to the Atlantic and Gulf States where these materials are so plentiful.

The great variation in the physical properties of clay makes it difficult to give definite rules as to the mixing.

It has been proven that such roads are well adapted to light traffic, and wear well under heavy, and are less noisy, dusty, and expensive than, and in cases preferable to, macadam.

By burning the clay at a moderate heat it loses its sticky quality, and becomes able to bear traffic even in the wettest weather.

The best sand-clay road is one in which the surface is composed of grains of sand in which the voids are filled with clay that acts like a binder. An excess of clay beyond this is detrimental. Where this condition exists for a few inches in thickness upon the surface of a road, it will bear comparatively heavy traffic for a long time. The materials should be mixed thoroughly while wet and puddled with water. This is easily secured after a hard or long rain, the clay having been previously spread and the larger lumps broken up.

CHAPTER VI

STREET DESIGN

THE object sought in the design and location of city streets, is a symmetrical arrangement or plan by which an easy and rapid means of intercommunication, together with plenty of light and air, may be secured at a minimum cost of construction. That many of the European cities and some of the larger ones in the United States have failed in obtaining such results, is instanced by the notably narrow and tortuous streets of London, Paris, Boston, and lower New York. On the other hand, Berlin is an exception to the general conditions in Europe, principally because of its enormous development practically within the past fifty years, while Washington, D. C., presents probably the best design that is to be found on this side of the Atlantic.

Frequently the location of a street is the result of topographical or other local conditions, which may neglect the considerations of grade, plan, and alignment. But with the growth of a community some intelligent arrangement must be adopted to provide for the present and future needs of all kinds of traffic, and for the water, sewerage, and lighting systems which are necessarily laid beneath the surface of the streets.

LOCATION. The factors governing the location of city streets are primarily the nature of the topography and the directness of communication.

Topography. Located with regard to this feature, the streets should be planned to secure easy grades for the benefit of traffic and should furnish satisfactory slopes for surface drainage, as well as the flow of water or sewage in the conduits placed beneath the surface; at the same time the cost of construction

should be a minimum. In hilly districts alignment is a secondary, but nevertheless important factor. With such prevailing conditions, the object to be attained is the maintenance of the integrity and uniformity of the plan, yet with avenues provided which will afford easy grades for the traffic and drainage.

Directness of Communication can be the controlling feature only where the ground is level or approximately so. On the other hand, where the land is particularly flat the question may be, not "how to avoid grade," but rather "how may grade be secured." With the obstacles of grade eliminated, a harmonious plan providing the shortest and easiest lines of communication may be easily adopted.

Street Plan. Two general methods in the arrangement of city streets may be said to obtain: 1st, the rectangular system; and 2d, a combination of the rectangular with intersecting diagonals.

THE RECTANGULAR SYSTEM consists of parallel lines intersected by other parallel lines at right angles to the former, and has the advantage of giving a maximum area for building purposes which may easily and readily be subdivided into lots of satisfactory form. It is the much more common method of arranging the streets, though perhaps not quite as satisfactory as the other.

In this system the avenues, designed for business purposes, should be parallel to each other, and follow the lines of maximum traffic, while the streets, devoted to residences, should intersect these at right angles. Where the city is divided into business and residential sections, the blocks should be square to admit of speedy intercourse; but where the two exist side by side, the blocks should be from three to four times as long as wide, with the residences occupying the shorter side of the rectangle.

New York City is, for the most part, an example of the rectangular system, but in the Borough of Manhattan, where the avenues run approximately north and south, and the streets east

and west, precisely the arrangement that should have been avoided has been secured. The city is very much longer on a north and south line than it is wide, and in consequence, and following a natural law, most of the businesses have been established on the avenues while the side streets serve for the resi-

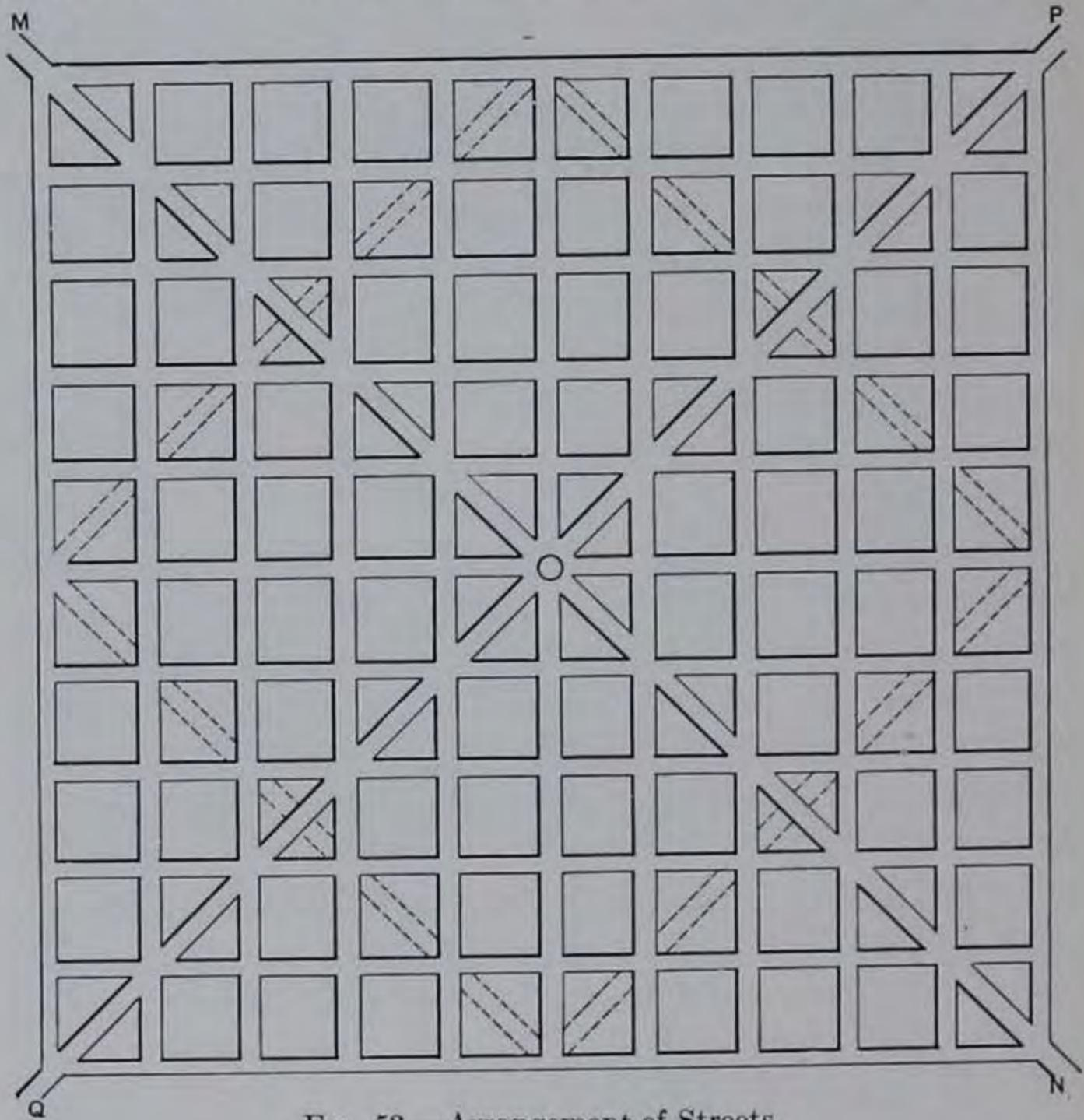

FIG. 53.—Arrangement of Streets.

dences. The avenues, therefore, receive the bulk of all kinds of traffic—subsurface, surface, and elevated—and yet instead of as many avenues as possible being provided to accommodate this traffic, the city is designed with the avenues from two to three times further apart than the streets, thus providing three times as

many thoroughfares in the direction where the requirements are the least, *i.e.*, east and west, as in the direction where they are most.

If the longer sides of the rectangles were north and south, it would further aid in the speed of transportation, since then the surface-cars at least would be required to stop at fewer corners.

Where the streets are numbered as, for example, 1, 2, 3, etc., the house numbers should in a similar manner agree so that the street number may indicate the location of the house. Thus all house numbers between 100 and 200 might be found between streets 10 and 20, and between 200 and 300 between streets 20 and 30, etc.

The Diagonal System consists of the rectangular, together with main diagonal thoroughfares for the purpose of giving direct lines of communication from one centre of the city to another.

It further provides breathing space at the intersections, which in congested districts are particularly desirable, affords light and air, increases the valuation of property, and possesses some æsthetic qualifications. While the principal advantage is that it saves distance, the principal disadvantage is that it consumes too large a proportion of building area. The advantages, however, may be emphatically said to outweigh the disadvantages, as increased valuation due to frontage more than counterbalances this; Washington, D. C., is the most notable exponent of this system of street design.

The following is an abstract taken from a paper, by Lewis M. Haupt, which shows more in detail the advantages of the arrangement.

"The systems may be divided into two classes: 1st, regular, and 2d, irregular. The first class may be subdivided into rectangular, diagonal, and circular; the second into every possible kind of distortion more or less intricate, according to the circumstances attending the growth of a city. The latter class is dis-

carded as being unscientific, expensive, inconvenient, and poorly adapted to the requirements of a growing community.

“ As people move through a city in every conceivable direction, it will be impossible to provide the shortest lines for all; but the case may be met by supposing a greater or less number of centres or points d'appui, to and from which the currents of daily life flow and ebb.

“ With reference to the subdivision of the first class, it is evident that, the straight line being the shortest distance between two points, the chord will be shorter than its arc, and hence the

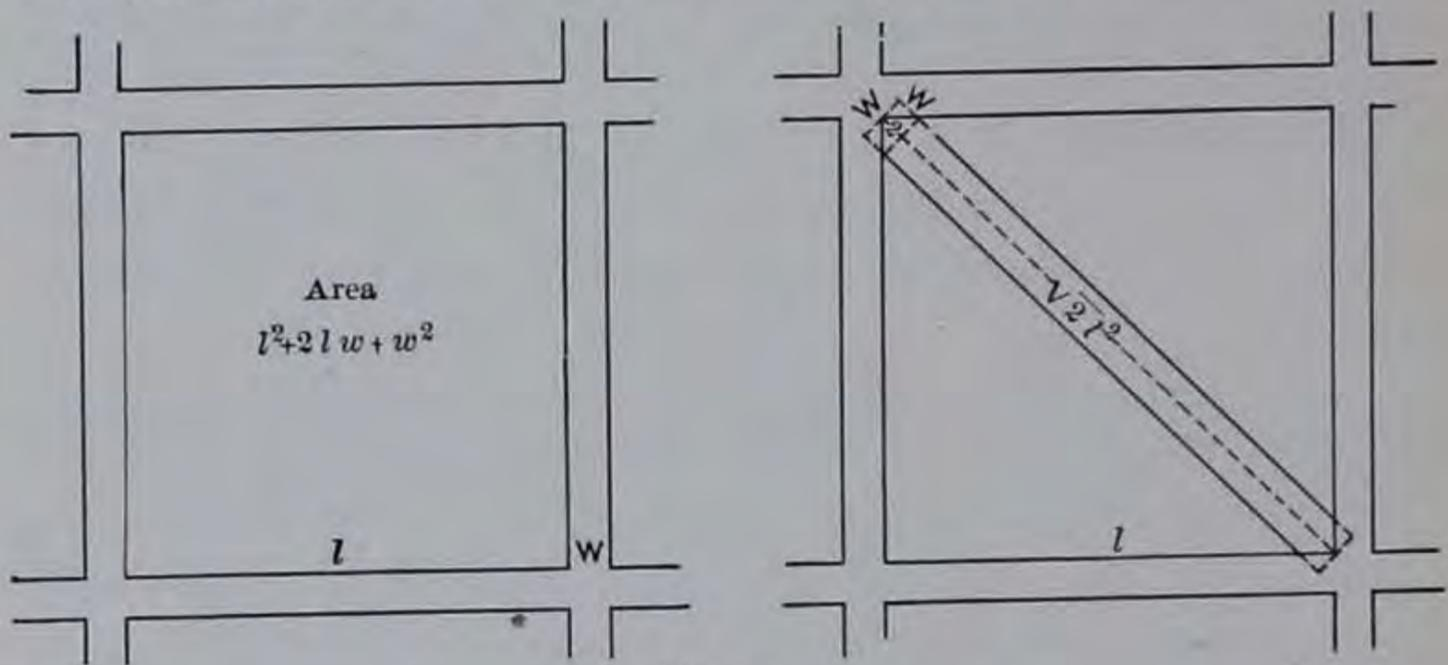

FIG. 54.

circular system is defective. The rectangular compels a waste of distance and time, and the diagonal by itself becomes the rectangular, so that no single system fulfils all possible requirements. A combination must, therefore, be resorted to, and that composed of right-line elements is both the simplest and most direct. A judicious arrangement of diagonal streets with the rectangular system will doubtless be found to meet more fully than any other the requirements of the case; but it is evident that if the streets be too wide or too numerous, the building areas will be correspondingly decreased and a certain proportion of people forced beyond given limits, thus increasing their distances. On the other hand, the diagonals will in general open new building lines with

more than residences enough to provide for all the displaced inhabitants.

“ To illustrate the utility of such a combination, suppose a portion of a town or city to be laid out in the form of a square whose side is L feet long, and in which the blocks are l feet square and the streets w feet wide.

“ Let the diagonals of the large square be opened as thoroughfares, and note their effect. The blocks or small squares extend from the middle of one street to that of its parallel, or from the building line of one block to that of the next; hence the length of a side of such a square must be $l + w$ (Fig. 54).

“ The area of the small square, including the streets, multiplied by the number of such squares, will give the area L^2 of that portion of the city, and the ratio of street to property area is the same for the small as for the large squares; but the area of the small squares is $(l + w)^2 = l^2 + 2lw + w^2$, in which l^2 is the property or building area, and $2lw + w^2$ is the street area; the ratio being $\frac{2lw + w^2}{l^2}$ and the percentage of street to property area,

$$\frac{2lw + w^2}{l^2} 100 \dots \dots \dots (A)$$

“ For any rectangle with streets of unequal widths, the general formula would be

$$\frac{bc + ad + bd}{ac} 100 \dots \dots \dots (A^1)$$

in which a and c are the sides of the rectangle, and b and d the widths of the streets. If these quantities are equal, each to each (A^1) becomes (A). The number (n) of blocks in a given square whose area is L^2 will be

$$\frac{L^2}{(l + w)^2} = n \dots \dots \dots (B)$$

“ If now two diagonals, \overline{MN} and \overline{PQ} be introduced, it is evi-

dent that where they cross the rectangular streets no additional area is taken from the private property of the city, but they will cut out of each of the small squares which they cross an area whose length is $\sqrt{2l^2} - \frac{w}{2}$, breadth w , and whose area for

one block, l^2 , is $(\sqrt{2l^2} - \frac{w}{2})w$ (see Fig. 54). For n blocks the total building area consumed from L^2 by both diagonals when n is even will be $2nw(\sqrt{2l^2} - \frac{w}{2})$, and the percentage of the building area will be $\frac{2nw}{n^2l^2}(\sqrt{2l^2} - \frac{w}{2}) \times 100$, which reduces to

$$\frac{w}{nl^2}(2.828l - w)100 \dots \dots \dots (C)$$

the formula for diagonals when n is even. If n be odd, C becomes

$$\frac{w}{nl^2}(2.828l)100 = 282.8 \frac{w}{nl} \dots \dots \dots (C^1)$$

“ If diagonals be opened, benefits will accrue both from the shortening of distance and the additional frontage which will be furnished, while but a small proportion of the inhabitants will be displaced. The greatest economy in distance will be in passing from M to O (Fig. 53), which by the square system is equal to L , and by the diagonal $L\sqrt{\frac{1}{2}}$, the ratio being $\frac{L\sqrt{\frac{1}{2}}}{L} = \frac{1.4142}{2} = \frac{70}{100}$, the numerator indicating the distance (in feet) by the diagonals, the denominator by the squares. This gives a gain of 30 per cent, which is the greatest amount possible and from which it diminishes to zero at P.

“ The total length of frontage on the streets in the square system is $4ln^2$. The diagonals give an additional length of $4n(\sqrt{2l^2} - w)$, and the percentage of increase is therefore

$$\frac{l\sqrt{2} - w}{ln}100 \dots \dots \dots (D)$$

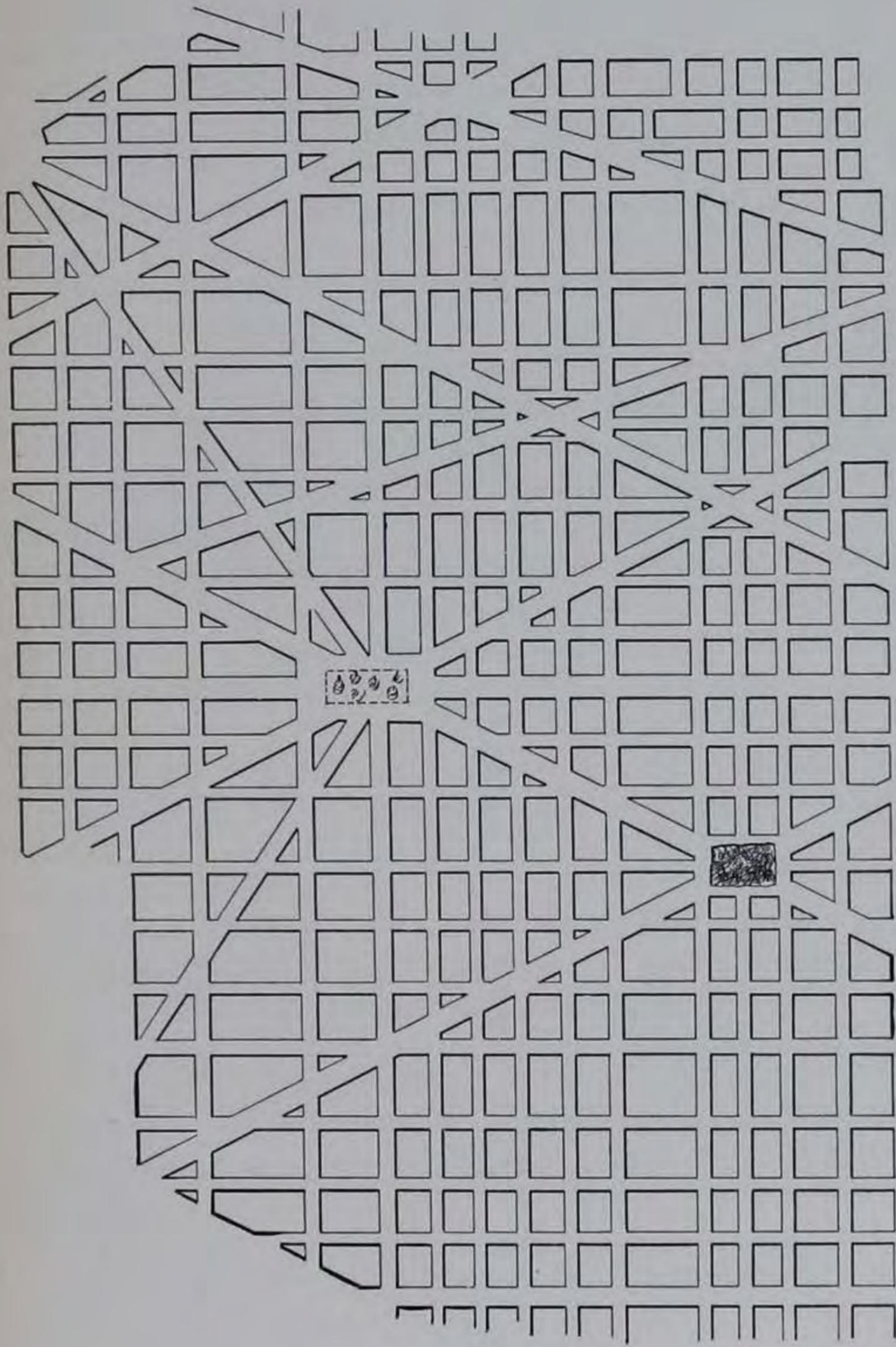

FIG. 55.—Arrangement of Streets.

“ The ratio of people displaced is the same as that of the area consumed by diagonals to the entire area L^2 .

“ To determine these values for any particular case, and so discover whether or not the diagonals will be beneficial, let $l = 500$ ft., $w = 50$ ft., and $n = 10$.

“ Formula (A) gives 21 as the percentage of *large or small* squares consumed by streets in the rectangular system.

“ Formula (C) gives only 2.82 per cent of additional building area consumed by diagonals.

“ Formula (D) gives 13 per cent as the increase in frontage due to diagonals, and it has been shown that the saving of distance varies from 30 per cent to nothing.

“ The number of people displaced, which is only 2.82 per cent, will be abundantly provided for by the additional frontage on the diagonals, revenues will be augmented by assessments on the new buildings erected, and a large saving will be effected in time and distance for a majority of the inhabitants by this combination of systems, which is therefore found to fulfil the requirements of practice more fully than any other.

“ Similar applications of the above formula will show to what extent the plans of cities already established or to be built, may be improved by the opening of diagonals; the most economical relation of street to building area, the proper distribution of the street area, and, by extending the analysis, the ratio of pavement to carriageway may also be readily determined. All of these questions have a direct bearing on the convenience, health, and extension of our cities.”

Fig. 55 shows the system adopted in laying out the streets of Washington, D. C.

Size of Blocks. In the rectangular system the blocks are in the form of a parallelogram, and where there is a preponderance of traffic in one direction it would seem to be the most satisfactory arrangement. They should be rather long and narrow, *i.e.*, with the length from 3 to 4 times the width, the latter being about 200

ft. This limiting width is determined by the depth of 2 lots, since it is undesirable and prohibited to have buildings so situated as to lack street frontage. A depth of 200 ft. permits of plenty of light and air in the rear of buildings, while a length of 600 to 800 ft. will provide sufficient cross streets to make all houses easily accessible. Probably the best arrangement of the houses in the rectangular system is with a main alley at the rear, about twenty feet wide, *i.e.*, wide enough to permit of two teams passing, centrally located and running the long way of the block. Sufficient alleys should connect with the side streets to insure ready entrance to the main one. This design permits of the tradespeople entering from the rear, and avoids the unsightly and disagreeable conditions that arise when house refuse, garbage, etc., must be collected from in front of one's main entrance.

Size of Lots. Lots 25×100 ft. are well suited to both business and residential needs. In New York City, however, where the values of real estate are so high, the frontage has been decreased in many cases to 20 ft. or less.

The depth is determined by the distance between streets, as no houses are permitted to be built unless facing on a thoroughfare. This prevents the unhealthy and unsanitary conditions that exist with "rear tenements," and insures light and air to the occupants of houses. To further provide for both of these there is an ordinance in the city of New York which allows only a certain percentage of any lot to be built upon.

In residential districts, particularly in small towns, where appearance and health are more carefully considered, the houses may be placed in the centre of two or more lots, thus securing breathing space, and adding to the looks. On the other hand, in business sections, within limits, it is highly desirable to have the buildings as close together as possible, not only to concentrate, but to promote trade.

Width of Carriageway depends upon the kind and amount of traffic, which in turn is related to the nature of the district in

which the street is located. Residential streets should be from thirty to eighty feet between curbs, specific values depending upon local conditions. In foreign cities usually some percentage of the width of street is taken. The smaller values seem to be much more prevalent in the East, while the general practice in the West tends toward the larger values. The above widths will ordinarily provide enough space for carriage or light delivery traffic, and at the same time afford sufficient light and air to assure a healthful condition. The latter, *i.e.*, the light and air, are beginning to be appreciated as important factors with the present pronounced tendency toward "skyscrapers," particularly in large cities. In view of these facts a height limit for buildings at Springfield, Mass., has been proposed the object of which is to limit the height of *all* buildings to 100 ft. in the business section and 80 ft. in residential, and also to preclude buildings being erected that are higher than $1\frac{1}{2}$ times the width of street. The reasons for these limitations are purely sanitary.

On business streets the distances between curbs vary from 80 to 140 feet. Such widths are necessary to provide against the congestion of traffic, and to permit of the operation of street-car lines. The above figures are seldom exceeded, though frequently the values in practice fall short of them. Thus in Brooklyn, N. Y., there are streets only thirty-four feet wide which contain two trolley-car tracks. Where surface lines exist it is better to have the streets wider than under normal conditions, and some advantage will be found in placing the tracks at one side of the street rather than in the centre.

Width of Pavement depends upon practically the same factors as width of carriageway. In residential districts the width of paved footwalks may be eight feet as a minimum, with the rest of the sidewalks sodded with grass and planted with shade-trees. Greater width is probably not needed, except under peculiar conditions, and the increased width only adds to the expense of construction, maintenance, and repair. In large cities and in the

business districts the entire space between building line and curb should be paved, and this width should have values between twenty and thirty feet.

Street Grades. The grade of a street is very important, as upon it depends the surface drainage, which is a factor in the health of the community, the grade of the water and sewer pipes beneath the surface of the street, and the load that may be hauled over the pavement. Such grades should as a rule be established before improvements are begun, as they are very much more economically located. "No arbitrary rule for a maximum grade can be laid down. But in a city that has been partially improved no grade should be established in excess of the maximum at that time in force, unless absolutely necessary." While, under ordinary conditions, the grade should be as small as possible, in Chicago the extreme case presents itself, for the city is so flat that it becomes a problem to secure drainage.

A grade of eight or ten per cent ought to be the maximum, though grades greatly in excess of this exist in many of our larger cities and are frequently used. Such values do not, of course, present the same difficulties to light pleasure traffic as to heavy trucking, but for the latter, ten per cent may be said to be the maximum. Beyond this it will be difficult and expensive to haul, particularly under unfavorable atmospheric conditions, despite the fact that for short distances horses are enabled to exert approximately twice their normal effort. In Duluth, Minn., a particularly hilly city, grades of 12 per cent are found; in Pittsburg, Pa., the maximum is 17 per cent; and in New York 18 per cent.

On such heavy grades the foothold should be as nearly perfect as possible, while the pavement should at the same time offer as little resistance to the vehicles. No such pavement combines these two characteristics to a marked degree, and in consequence foothold takes precedent over smoothness of surface. For this reason brick, cobble, or granite block should be used on

steep grades, though on inclines of 5, 6, and 7 per cent asphalt seems to be chosen by drivers in preference to the rougher pavements.

The more important factors influencing the choice of grade are drainage, both surface and underground, cost of construction, consideration of traffic, and the effect on the value of abutting property.

Grades at Street Intersections. The establishment of grades at street intersections more often requires the use of judgment and ingenuity than the following of some rule of thumb. The plan adopted by Herring and Rosewater, however, in the setting of grades at intersections in the streets of Duluth, Minn., is frequently quoted, and is perhaps as satisfactory a method as has been so far suggested.

At intersections, in the business sections, grades are flattened to three per cent for the width of the roadway of the intersecting streets, and that of the curb is flattened to eight per cent for the width of the intersecting sidewalks. Grades of less amounts, on roadway or sidewalk, are continuous. The elevation of property corners is found by adding together the curb elevation at the points facing the property corners and also the sum of the widths of the 2 sidewalks of the corners multiplied by $2\frac{1}{2}$ per cent, and dividing the whole by 2. This gives an elevation equal to the average elevation of the curbs opposite the corner, and an average rise of $2\frac{1}{2}$ per cent across the width of the sidewalk.

Another method of adjusting grades at street intersections is to give the 4 building corners, the 4 curb corners, and the 8 points on the curbs opposite the building corners all the same elevation. This arrangement is satisfactory only when the grade is small, *i.e.*, under 3 per cent.

The most usual method of establishing grade at intersections is by considering the grades of the centre lines alone, but this, especially on side hill streets, leads to confusing and unsatisfactory results.

Side Hill Streets present some difficulties at corners and crossings where the grade is at all excessive. With normal conditions, a street will be located symmetrically with regard to a longitudinal centre line, and the same grades, etc., will obtain on one side as on the other; but where transverse grades exist, other arrangements will have to be made in determining the elevation of building corners, slope of pavement, elevation of curb corners, transverse grade, position of crown, depth of gutter, height of curb, etc., etc. Under all circumstances a grade of $\frac{1}{8}$ in. to $\frac{3}{8}$ in. per ft. should be given the sidewalk to secure drainage, and the height of curb should have a minimum value of 3 ins. and a maximum of 10 ins. To accommodate the street, then, to the grades, carefully exercised judgment will have to be used.

It is the general practice where the transverse grade is somewhat small, to swing or throw the centre of the crown toward the high side of the street, to make the height of curb on opposite sides of the street unequal, or provide different grades for the sidewalks; but where the grade is large, the whole street may have to slope transversely with the grade, and under extreme conditions the higher side will have to be terraced.

STREET DRAINAGE

Drainage of streets may be divided into two classes: surface, and subsurface.

Surface Drainage is for the purpose of collecting in the gutters all water falling either upon the foot- or the carriageway, and so directing it that it may be discharged into a catch-basin, sewer, or some natural outlet. To care for the water falling on the footway, a grade of one-eighth inch per foot should be given, away from the house-line toward the gutter; this will insure the water flowing into the latter while the water falling on the carriageway will be directed toward the same gutter by means of the crown.

Gutters should be deep enough to carry off the maximum

amount of storm waters. They are formed of the same material as the roadway itself where that is asphalt, wood, granite block, etc., but on streets where gravel or macadam are used, cobble or blocks of stone will have to be employed to avoid the scouring action of the storm waters. Asphalt, when subjected to the continued action of water, rots, and to prevent this disintegration by the storm waters in the gutters, a coating of pure bitumen is painted along a narrow strip next the curb where the storm waters flow. On the very superior gravel and broken-stone roads of Central Park, New York City, the gutters are formed of a shallow trough about fifteen inches wide and four inches deep, which drain into catch-basins placed in the path of the gutters.

Where the streets possess curbs, the gutters are usually formed by the vertical face of the curbstone and the pavement adjacent to it, but on the streets of country towns the gutter is often placed some distance from the walk, where perhaps no curb exists, and it is then formed by paving the bottom of a trench with small-sized stone to prevent erosion. The depth of the gutter should be from three inches to ten inches, and should be uniform on streets with any grade, though on level, or approximately level, streets the depth of the gutter will vary so that proper drainage may be effected.

The grade of the gutter in all ordinary cases depends upon the longitudinal grade of the street, but a slope of 1 in 100 at least ought to be provided to secure satisfactory drainage.

Curb. The curb serves the double purpose of holding both the sidewalk and pavement of the carriageway in place, and at the same time acting as a sort of shoulder for the gutter to confine the storm waters there that are directed to the sides by means of the crown. Generally speaking, curbs should not be higher than ten inches nor less than three inches, as the former make them difficult to step up to, and the latter will be too shallow to prevent the water from flowing over the walk. Curbs are usually formed of slabs of stone about 6 ins. thick, 18 ins. to 24

ins. deep, and varying in length; but they are often made of concrete, especially when formed in combination with the gutter. A stone that will resist the action of traffic, *i.e.*, wheels scraping along the front face, and one that is non-absorbent, is best suited to the purpose, as it will thus better resist the weather action. For this reason, granite, limestone, bluestone, and sandstone are frequently used. All exposed faces and joints are usually dressed so as to secure a close, even contact, and present a pleasing appearance.

The face next the gutter is inclined away from the vertical

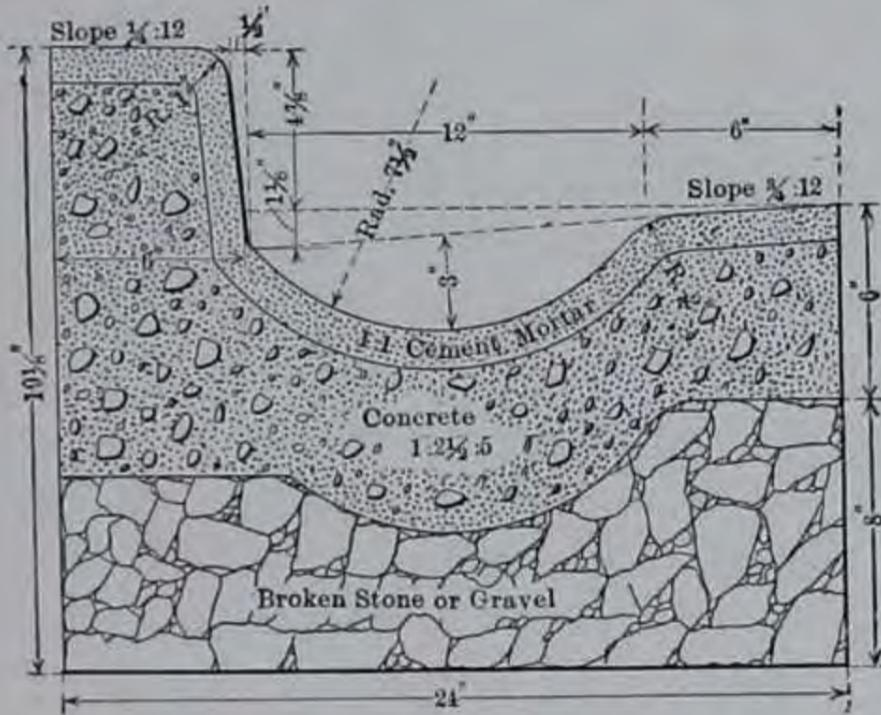

FIG. 56.—Concrete Curb and Gutter.

to prevent the wheels from too readily breaking or chipping the curb when wagons are backed up against it, while the horizontal face is given the same slope as the sidewalk for drainage.

At corners the curb should be curved, the minimum radius being about 2 ft. and the maximum about 12 ft.; the more usual values, however, lie between 6 and 12 ft. Too large a radius is expensive and not so convenient for people crossing the streets.

The above cut shows the design of a concrete gutter and curb.

“The most obvious thing about it is the curved waterway in the form of a segment of a circle with its chord inclined at the

same slope as the last quarter of the street and the first 6 ins. of the gutter. This slope is $\frac{3}{4}$ in. to 1 ft. This plane lip practically continues the roadway and makes it possible to secure a smooth joint with the pavement, and thus allows the water to run freely into the gutter, which is the main feature of the design. This segment has about a 12 in. chord and a 3 in. rise, making its area 25.2 sq. ins. or about that of a 6 in. pipe (28.2 sq. ins.). It is evident that there is a chance for a large amount of water to run before the triangular space between the chord and the level line from the edge of the gutter is filled. This latter space represents the ordinary gutter of one plane.

“The advantages of a combined concrete curb and gutter of this type in the way of looks, efficiency, and cost are so great that it seems the obvious thing wherever a good concrete stone is available at a reasonable price.”

Crown. The crown on city streets as upon country roads consists either of two intersecting planes or of a curved profile. Curves are the much more usual form and are either circular or parabolic. They have the advantage of giving a flat profile in the centre, where the most traffic is, and where it is most desirable that it should be level, besides giving deep shoulders or gutters, thus reducing the area that must be devoted to such purposes.

The crown is naturally for the purpose of directing the surface waters toward the gutters, and the smoother the pavement the less it should be. But it should be stated that while asphalt is the smoothest pavement, and should therefore receive the least crown, in some cities it is the practice to give it the maximum value. This is because the foundation, however well built, will give to a slight extent under normal traffic conditions, and the asphalt, with no support and possessing no structural rigidity in itself, fails to stand up under the imposed loads. Depressions form, in which rain collects and rots the asphalt.

For asphalt, sheet or block, brick, or wood, the crown will be

about the same and vary from 1 in 50, as a minimum, to 1 in 20, as a maximum. Macadam will vary from 1 in 24 to 1 in 12, and granite blocks will have a crown of about 1 in 30. Such values will, of course, be modified to some extent on side hill streets to better accomplish the required results under the peculiar existing conditions.

Longitudinal Grade. The longitudinal grade should, for efficient drainage, be about 1 per cent, though in cases, as small a grade as 1 in 300 has successfully disposed of the surface drainage. Whatever the grade of the axis of the street is, it will, within small limits, determine the grade of the gutter.

Drainage at Street Intersections requires care and judgment, for usually the most traffic of vehicles and pedestrians occurs at these points. It is the general practice, or at least the more common one, to place the catch-basins at the corners, and hence the greatest volume of water occurs at these points. Unless the gutters are unusually wide and deep, thus making it not only difficult crossing for pedestrians, but also turning the corners for vehicles, the water, in times of heavy rains, will tend to cover the footwalk, and in cold weather the catch-basins' mouth may be easily clogged, leaving a miniature lake for people to wade around or through.

If, on the other hand, the gutter is carried under the crossing stones, then the possibilities of it becoming choked are correspondingly great.

To obviate this condition with the consequent inconvenience to pedestrians, the catch-basins should be placed in the gutter some distance from the corner.

Subsurface Drainage. It is just as important that the subsurface of a city street be well drained, to support the overlying pavement, as of country roads. This may be accomplished by porous tile pipe with closed joints being placed under each gutter, and draining into the catch-basins.

Catch-basins are simply vaults arranged conveniently to

receive the surface drainage, and for the purpose of collecting débris, paper, sand, stone, sticks, etc., carried along with the water, that it may settle there instead of flowing through other conduits with the possibility of clogging them. These catch-basins are placed below the surface of the ground, the mouth being protected by iron bars or screens so as to readily admit the water and yet prevent larger solids from entering. Periodically they are cleaned out and are better when they will admit a man's body for the purpose.

TREES

Apart from the æsthetic side of the question, trees furnish shade, temper the atmosphere, absorb water from the roadbed, and act as a shield against snow and wind. The financial aspect should be considered also, as well-placed shade-trees increase the valuation of property. On the other hand, producing shade and acting as a wind-break to the road, trees prevent the very desirable wind and sun action which are so important and effective in drying out the soil.

But whatever the disadvantages of trees may be, it is and has been the practice in the most progressive road-building countries to plant them systematically along the highways and more particularly along suburban residential streets.

In France all roads having a width of 32.8 ft. and over, have a single row of trees on each side, the trees being placed at a distance of 16.4 ft. to 32.8 ft. apart and on wider roads double rows are established. In some countries fruit-trees are planted from which the government receives a revenue by the sale of the privilege to pick the fruit.

The kind of tree to be used depends principally upon the local conditions, *i.e.*, climate, environment, soil, air, space, etc., but one should be selected that is not easily affected by long dry or wet spells, dust, heat, smoke, foul air, soot, insects, injury, etc.,

etc. They should provide plenty of foliage, be rapid in growth, yet long-lived and pleasing in form.

The trees are usually placed from twenty-five to fifty feet apart so that their limbs may not interfere, and where there is a pavement the entire width of the walk, are protected by an iron or stone grating around the base of the trunk.

In Massachusetts, where during the past few years tree planting along the public highways has received some attention, the following varieties were planted in 1905, showing the variety and choice of selection: 1,737 maples:—sugar, Norway, white; 1,000 elms; 538 oaks:—red, scarlet, white, pin; and some six hundred of various kinds, including the white pine, locust, willow, etc. The cost of these trees in 1905 was \$1.14 each, and in 1906 \$1.01.

According to the Commission, the destruction of the trees results from small boys, careless drivers, stray cattle, drought, and insects.

CHAPTER VII

STONE PAVEMENTS

COBBLESTONE. While it is a fact that cobblestone pavements are seldom, if ever, laid to-day except where the grade or the traffic is heavy, mention must be made of them because of their extensive and almost exclusive use during the period when pavements were first being laid in American cities.

A **COBBLESTONE PAVEMENT** is one consisting of rounded stones placed upon a suitably prepared foundation of either the natural soil or sand. Originally, most of the pavements in the United States were constructed of this material because of the advantages they presented in the cheapness, accessibility, and durability of the stone, though their many disadvantages have been the means of other pavements being substituted for them. A cobblestone is any well-rounded, water-worn stone, taken from beaches or gravel pits, and, as used in pavements, about the shape of an egg, though much larger. For paving purposes the stone should never be less than 4 ins. in diameter nor greater than 8 ins., and from 5 ins. to 10 ins. deep. The stone may be laid upon the natural soil, though this is hardly satisfactory, or upon a foundation of loamy sand of about 6 ins. in depth. If a greater depth of sand is used, or if the sand is too clean, it is found that the cobbles have a tendency to overturn under the action of traffic. The stones are set on end, that is, with the long dimension vertical and rammed into place by a 50 lb. rammer, while over the surface is spread a 2 in. layer of sand or gravel for the purpose of filling the joints and aiding in holding the stones in place.

There are few advantages and many disadvantages connected with a cobblestone pavement. It is cheap and furnishes an excellent foothold for horses; but, on the other hand, it is rough, noisy, pervious, requires a maximum of tractive force, has a poor bond at joints, is easily rutted, hard to keep clean, unsanitary, and in fact may be said "never to give satisfaction, being only a substitute for a pavement."

Cobblestones may, however, be used to advantage where heavy loads are to be hauled on trackways, over which the wheels run, and between which the rounded stones are laid to offer a foothold to the horses.

This applies more particularly to one-horse loads, or where two or more are hitched ahead of each other, as is the custom to a considerable degree in Europe, for where the horses are harnessed two abreast, as in America, so that they walk in the tread of the wagon, *i.e.*, on the track ways, no advantage is to be gained.

BELGIAN BLOCK

This pavement superseded the "barbarous" cobblestone because of its superiority, though it in turn has been discarded in favor of the granite-block, or block-stone pavement for a like reason, where the demands of traffic have been such as to require a covering of this general character. It derives its name from the fact that these pavements were first built in Brussels, Belgium, and it is purely a generic term designating any pavement where blocks of a given shape and size are used. Due to the fact, however, that most pavements of this character, as laid in and around New York City at least, were of trap rock, any covering with trap as the material came to be known by the name of Belgian block.

The pavement possesses some advantages over cobblestone, yet, on the other hand, it lacks some of those fundamentally necessary characteristics which make an ideal covering. The

material is so hard that it is extremely durable, lasting longer than any other stone, and because of the shape, the blocks are more stable when in place than cobble, though not altogether satisfactory in this respect either; it is cleaner, and therefore less unsanitary, because of the smaller joints, but it is rough and noisy, and, when worn smooth by traffic, lacking in foothold.

The blocks should be of trap rock "of durable and uniform quality, each measuring on the base or upper surface not less than 6 nor more than 8 ins. in length, and not less than 4 nor more than 6 ins. in width, and of a depth not less than 6 nor more than 8 ins. Blocks of 4 ins. in width on their face to be not less than 4 ins. at the base. All other blocks of transverse measurement on the base to be not more than 1 in. less than on the face, but no block on the face should be of a less width or length than 4 ins. Blocks laid along curbs must in all cases be 8 ins. deep, and at least one-third of the whole number must be of like depth. The faces of the blocks must be smooth and free from all bunches or depressions."

The blocks are generally laid in parallel courses across the street upon a sand foundation six inches in depth, and covered with a layer of sand which is swept into the joints until they are filled, after which the pavement is thoroughly rammed until the upper surface has been brought to grade. A better way, however, is to lay them on the diagonal so that the joints may not then be parallel to the direction of traffic. Though this is expensive, the results in wear seem to warrant the practice.

GRANITE BLOCK

In view of the fact that both cobblestone and Belgian block have proven unsatisfactory through their inherently weak characteristics, which more or less unfit them for heavy grades and traffic, granite block has replaced them; for it not only com-

bines some of the superior qualities of the two former to a degree, but it possesses desirable qualities of its own. This result arises chiefly from the judicious selection of a material suited to the needs of the traffic using it, together with a choice of shape and size that overcome in a measure the disadvantages of the others.

The principal advantages of such a block pavement are that it is suitable to heavy grades, is durable, and furnishes a good foothold; but, on the other hand, under certain atmospheric conditions, *i.e.*, when the atmosphere is saturated with moisture, or when there is a slight precipitation of the same, it becomes slippery; certain grades of stone polish smooth under the action of traffic with the same result, it is rough at best, noisy, hard to keep clean, and unsanitary.

The very hardest rocks, such as basalt and the true granites, are not at all suited to block-stone pavements; for while it is true they are extremely durable, resulting in a minimum of wear and consequently are long-lived and cheap, they are so hard as to become in time smooth and fail to furnish a good foothold. Rounded edges and a slight amount of precipitation cause the blocks to become as slippery as though grease had been spread over them.

A syenite, *i.e.*, a granite in which the hornblende predominates, or a hard sandstone, such as the Medina sandstone found in central and western New York, are very much better; particularly the latter, for while it is less durable, its physical constitution is such that it never polishes, becomes slippery, nor wears unevenly. In the form of blocks this sandstone has been extensively used both in the western New York and Lake cities, where, as in Buffalo and Rochester, it has given eminent satisfaction. Limestone has also been employed, but it lacks durability, and wears so unevenly that it is far from being a satisfactory substitute for either granite or certain grades of sandstone.

SIZE OF BLOCK. Aside from other unfavorable characteristics,

the size and shape of both cobble and Belgian block are against them. In the former pavement, the stones are set on end as an egg would be, receiving their support through the lateral pressure of the adjacent stones, and by the fact that one end is embedded in a layer of sand. This resulted in the pavement becoming quickly rutted, which applies, but to a lesser degree, to the Belgian block. The object, therefore, in the selection of a paving stone was to secure not only one that was durable, but one which, because of its shape, should form a stable pavement.

“For stability a certain proportion must exist between the depth, the length, and the breadth. The depth must be such that when the wheel of a loaded vehicle passes over one edge of its upper surface it will not tend to tip up. The resultant direction of the pressure of the load and the adjoining blocks should always tend to depress the whole block vertically; where this does not happen, the maintenance of a uniform surface is impossible. To fulfil this requirement, it is not necessary to make the blocks more than 7 ins. deep.” The width should be such as to give the horses a good foothold, and therefore, in a measure, this dimension depends upon the size of a horse’s hoof. It has been found, and practice requires, that this factor be from 3 to 4 ins. The length varies from 6 to 14 ins., but depends primarily upon (1) the necessity of breaking joints properly to prevent ruts, and (2) the need of keeping blocks small to prevent splitting or becoming unwieldy.

Whatever the size of the blocks, however, all specifications require that they shall be square, *i.e.*, parallel faces shall be of the same dimensions. This precludes wedge-shaped stones, which are to be carefully guarded against, as they give but little support to adjoining blocks, and are themselves unstable in the pavement. It is particularly essential also to see that the blocks do not vary in depth by more than one-half inch, as greater variations cause irregularities in the surface. All stones receive

approximately the same amount of ramming so that with unequal depths all blocks do not reach the same firm and unyielding foundation. When an excessive load is applied, therefore, the shallower stone is forced down below its neighbors.

THE FOUNDATION for any pavement should be properly prepared, and cobble or block stone is no exception to this rule. To accomplish this, the subgrade of natural earth should be carefully examined, unsatisfactory material having its place filled with fresh earth or sand, and the resulting foundation brought to grade, by rolling so as to form an evenly compacted surface. Upon this surface is usually placed what is termed the *cushion coat*, which is nothing more nor less than a layer of sand, and which acts, as the name indicates, as a cushion for the blocks of stone to be placed upon. These blocks, no matter how carefully dressed to dimensions, have irregular surfaces with projections or depressions on the several faces. If in this condition they were placed upon an unyielding foundation, or even upon a semirigid one, it would happen that most of them would fail to receive uniform support over the under face, with the result that the pavement would be speedily rutted and broken up by hollow spots. The sand or cushion coat prevents this, for it quickly adjusts itself to the irregularities of the surface with which it is in contact, so that any load applied to the upper surface of the block is transmitted uniformly through the sand to the foundation below. This is as it should be, for if the total load on any one block, when a wheel is passing over it, were carried to the subgrade by only a small portion of the block—as, for example, by means of a downward projecting point—the intensity of pressure would be so great as to cause the block to break through the surface of the subgrade, and depress the surface beneath that of the neighboring stones. The cushion coat should never be less than one inch in depth, and should be of clean, dry sand. If it is dirty, that is, if it contains loam or vegetable matter, it will not be so mobile in the former case, and in the latter the

process of decomposition will leave voids. If damp or wet, it should be heated to drive off the moisture, since the presence of the same causes heaving under the action of frost.

LAYING THE STONE. Upon this cushion coat of sand, the blocks should be laid in parallel courses across the street, from the sides to the centre, with the long edge perpendicular to the axis of the street. The blocks should break joints with those in the rows adjoining by not less than two inches, and these joints should be as small as possible. Wide joints increase the wear and do not improve the foothold. The blocks are then brought to the required grade and profile by ramming, for which purpose a rammer of about fifty pounds in weight, with a butt not less than three inches, is used. This ramming should be continued until the blocks sink no further under the application of the blows, and if they do, then they should be removed and more sand placed beneath them. If any of the blocks, on the other hand, rise above the general elevation, they must be removed, and reset till the desired condition is obtained.

THE JOINTS are filled with a variety of materials, such as sand, a grout of cement mortar, bituminous cement, etc. The purpose of the joint filling is, of course, to prevent any moisture from reaching the foundation, so that, all other things being equal, that which best satisfies this requirement is the most satisfactory. For this reason sand is not so good as either the cement mortar or the bituminous cement. But the mortar used as a joint filling is so easily chipped under the action of traffic that the better specifications call for the bituminous cement. This latter may be tar distillate, a mixture of tar distillate and refined asphaltum, or various mixtures of asphaltum, creosote, and coal tar.

The specifications for New York City prescribe:

Refined Trinidad asphaltum.....	20 parts.
No. 4 coal-tar distillate.....	100 parts.
Residuum of petroleum.....	3 parts.

Such a joint filling should be brought hot to the place where

the stone is being laid, and should be kept so until used. When the pavement is ready for the joint filling, the joints are first filled with small clean pebbles or gravel to within two inches of the surface, and the bituminous cement or other mixture is then poured into the joints. More gravel is then swept into the joints, followed by more cement, and this procedure is continued until the cement flushes to the top. On top of this finally is then placed fine gravel or sand. The amount of cement to be used will vary with the size of the joints, but will average between three and twelve gallons per square yard of pavement.

The method of laying the blocks at intersections will be the same as for brick pavements while on steep grade, to afford better foothold, they may be placed on edge.

The complete specifications governing the laying of granite-block pavements in New York City are appended below.

SPECIFICATIONS

FOR REGULATING, GRADING, AND PAVING OR REPAVING WITH
 A GRANITE-BLOCK PAVEMENT ON A CONCRETE FOUNDATION
 THE ROADWAY OF.....
 FROM
 To
 TOGETHER WITH ALL WORK INCIDENTAL THERETO.

1. EXTENT OF WORK. The work shall consist of regulating and grading the entire roadway (or if the street is already paved, of removing the old pavement), setting and resetting curb, laying sidewalks where required, and laying a granite-block pavement and all work incidental thereto, all in accordance with the plans and specifications on file in the office of the Bureau of Highways.

2. OBSTRUCTIONS. The contractor shall remove at his own expense, when directed by the engineer, any encumbrances or obstructions on the line of work, located or placed there prior to or after its commencement.

CATCH-BASINS, MANHOLE HEADS, ETC. Such catch-basins, manhole frames and heads for sewers, water pipes or other conduits belonging to the City on the line of the work, as may be designated, shall be reset to the new grades and lines by the contractor without extra charge therefor, and they shall be brought to such grades with brick masonry of the same thickness as that originally used, laid in hydraulic cement mortar.

4. NOISELESS MANHOLE COVERS.—Asphalt-filled noiseless covers, complete, for water and sewer manholes of the design approved by the engineer, shall be furnished and set wherever directed by the engineer. They shall be made according to general details to be furnished to the contractor and of such size as will fit the present manhole heads. The old covers to remain the property of the City.

5. REMOVAL AND OWNERSHIP OF OLD MATERIALS. All old material which will not be used in the work, excepting bridge stone and specification paving stone, shall become the property of the contractor and be removed by him; the remainder, as specified above, shall be delivered when required, and piled in such corporation yard or elsewhere as the engineer may determine, and all at the expense of the contractor.

6. PREPARATION OF FOUNDATION. When the old material has been removed, that to be used again shall be compactly piled on the side and the roadway graded to the required shape and depth below the proposed finished pavement. All unsuitable material shall be removed and replaced with that which is satisfactory.

7. On the roadbed graded and prepared as hereinafter set forth, the stones shall be relaid at right angles to the line of the street. They shall be well bedded on two inches of sand, with surface joints not exceeding three-quarter ($\frac{3}{4}$) inch, the joints to be brushed full of the same material and the stones rammed to a solid, unyielding foundation, with their top surface conforming to the lines and grades shown by the plan of the work.

8. INSPECTION AND PILING OF MATERIAL. The material for construction when brought upon the street shall be neatly piled so as to present as little obstruction to travel as possible. No material shall be used without having been first inspected and accepted by the engineer, the contractor furnishing all labor necessary for inspection without any charge. Should the work be suspended for any cause, the materials shall be removed from the line of the work at the direction of the engineer, and unless so removed by the contractor upon notice from the said engineer, they will be removed by the president, and the expense thereof charged to the contractor.

9. CITY MONUMENTS. The contractor shall not excavate around such city monuments and bench-marks as may come within the limits of, or be disturbed by the work herein contemplated nearer than five (5) feet, or in any manner disturb the same, but shall cease work at such locations until the said monuments or marks have been referenced and reset or otherwise disposed of by the chief engineer of the Bureau of Highways. The necessary labor to remove, care for, and reset all such monuments and bench-marks shall be furnished without charge therefor by the contractor.

10. CURBSTONE. Old curbstone which can be redressed to a top width of not less than four and one-half ($4\frac{1}{2}$) inches and not less than sixteen (16) inches deep and are of the quality hereafter specified, shall be redressed, rejointed, and reset as directed below.

11. QUALITY OF. New curbstones shall be free from seams and other imperfections and equal in quality to the best North-River bluestone. They shall be () inches in depth, and from three and one-half ($3\frac{1}{2}$) to eight (8) feet in length, and not less than five inches in thickness, except as noted for bottom of curb.

12. HOW DRESSED. The face for a depth of nine (9) inches and the top on a bevel of one-half ($\frac{1}{2}$) an inch in its width of five

(5) inches shall be dressed to a surface which shall be out of wind and shall have no depressions measuring more than one-quarter of an inch from a line or straight edge of the same length as the curbstone. The remainder of the face shall be free from projections of more than one-half ($\frac{1}{2}$) an inch and the back for three (3) inches down from the top shall have no projections greater than one-quarter ($\frac{1}{4}$) of an inch measured from a plane at right angles to the top. The bottom of the curb shall be rough-squared with a width of not less than three (3) inches.

13. JOINTS OF. CURVED CURB. For the full width of the stone for a distance down of four (4) inches from the top, and therebelow for a width of one and one-half inches back from the face to a point twelve (12) inches below the top of the curb, the ends shall be squarely jointed with no depression greater than three-eighths of an inch, measured from a straight edge. Curved curb corners shall be cut with true radial joints and be set accurately to such a radius as may be required in three (3) foot lengths. It shall be paid for as straight curb, and must comply in all respects with the above requirements therefor. The cost of excavation necessary for curb-setting shall be included in the price paid per linear foot of curb. The sample of the curbstone showing the dressing and the jointing required can be seen at the office of the chief engineer of the Bureau of Highways.

WHEN SET IN CONCRETE. The curb shall be set on concrete as shown by detail on plan, and shall be set truly to line and grade on a face batter of one and a half inches in its depth.

14. CHARACTER OF CONCRETE. The concrete foundation for curbstone shall be not less than six (6) inches thick and seventeen (17) inches in width and be of the materials and proportions hereinafter described, except that the broken stone shall be not less than one-quarter ($\frac{1}{4}$) nor more than one and a quarter ($1\frac{1}{4}$) inches maximum dimensions; the curb shall be immediately bedded on the centre thereof, with a bearing for its full length as soon as the concrete is laid, and it shall be at once backed up with

concrete for a width of six (6) inches, extending from the bottom bed to within four (4) inches of the top of the stone. The concrete so used will be paid for at the general price per cubic yard for concrete.

15. IN FRONT OF CEMENT WALK. When curb is set in front of a monolithic walk, the space between the curb and sidewalk foundation shall be completely filled with concrete similar to that described above, to within two (2) inches of the top; the remaining space to be filled with Portland cement of the quality hereinafter specified, mixed with an equal part of crushed stone used for wearing surface of such walks. Wherever curbstones, however set, shall have become displaced or damaged from any cause, such curbstone shall be reset or new ones shall be furnished in their place and no compensation therefor shall be allowed.

16. SIDEWALKS. On repaving work the first course of flagstones interfering with the work of curb-setting shall be taken up and relaid to the new curb grade, at the expense of the contractor. Any damage done by the contractor to sidewalks in curb-setting, handling, or in the storage of materials shall be made good by him, at his own expense, as shall be directed by the engineer.

17. HOW LAID. All flagging to be relaid shall be firmly and evenly bedded to the grade and pitch required, on three (3) inches of steam ashes or sand free from loam or clay and the work brought to an even surface, with all joints close and thoroughly filled for the full depth with cement mortar composed of equal parts of the best Portland cement and clean, sharp sand, and left clean on the surface; and all earth, débris, and surplus material shall be removed from each block and the sidewalks swept clean as soon as the work thereon has been completed.

18. CONCRETE.—CEMENT.—PROPORTION. The concrete shall be made of the best quality of Portland cement, samples of which must be submitted at least ten (10) days (Sundays and holidays excluded) before using, for the inspection and approval of the

chief engineer. All cement shall be of a uniform quality, color, and weight, and briquettes of one (1) square inch section shall develop or exceed the following tensile strength:

Neat—four (4) hours in moist air, twenty (20) hours in water	200 pounds
Neat—one (1) day in air, six (6) days in water	400 pounds
One (1) of cement, three (3) of sand, one (1) day in air, six (6) days in water	150 pounds

The concrete shall be composed of one (1) part of cement, three (3) parts of sand, and six (6) parts of broken stone. The unit of measure shall be the barrel of cement as packed by and received from the manufacturer.

19. SAND AND STONE. The sand shall be clean, coarse, and sharp, and be free from loam or dirt. The broken stone shall be of trap, granite, or limestone or such other stone taken from the line of work as shall be satisfactory in the judgment of the engineer. It shall be entirely free from dust and dirt, and be of graded sizes such that all will pass through a revolving circular screen having holes two and one-half ($2\frac{1}{2}$) inches in diameter and be retained by a screen having holes one-half ($\frac{1}{2}$) inch in diameter. The sand and stone shall be placed upon board platforms and be kept free from dirt, and the cement shall be properly blocked up and protected from dampness.

20. MIXING. The sand and cement shall be mixed dry, then made into mortar by the addition of water, when the broken stone shall be added and the whole mass thoroughly mixed. The concrete shall then be spread upon the subgrade and rammed so as to fill all the voids of the stone with mortar and bring the surface exactly ten (10) inches below the finished pavement. If a machine be used for mixing, the above operation may be varied as may be required. No concrete shall be used that has been mixed more than one-half hour. The concrete shall be protected from the weather when deemed necessary by the engineer. Before laying concrete to connect with, rest upon, or overlap

concrete previously laid, the entire surface of contact of the latter shall be swept and washed clean of all dirt and mortar particles.

21. NO CARTING. No horses, carting, or wheeling shall be allowed on the concrete before the same has set, except on planks furnished and laid by the contractor.

22. THICKNESS. The concrete foundations shall be six (6) inches thick, except where otherwise specially ordered.

23. BRIDGESTONES.—QUALITY. When required, old bridgestones shall be redressed, rejointed, and relaid as hereafter directed for new bridgestones, and for such purpose shall be hauled to the necessary point or points by the contractor. Bridgestone broken by being so hauled, redressed, or relaid shall be replaced by the contractor at his own expense. New bridgestones shall be of the same quality of granite as the blocks, free from all imperfections.

24. DIMENSIONS. They shall be eighteen (18) inches wide, of a uniform thickness, not less than six or more than eight (8) inches in depth, and from three and one-half ($3\frac{1}{2}$) to eight (8) feet in length, except that in special cases, between railroad tracks, they may be of such dimensions as may be approved by the chief engineer of the Bureau of Highways.

25. DRESSING. The top shall be dressed to a surface not varying in evenness more than one-quarter ($\frac{1}{4}$) of an inch. The sides and ends shall be dressed square down and the latter cut to a transverse bevel of six (6) inches in the width or to such other bevel as may be directed, and the jointing from top to bottom shall give joints not greater than one-quarter ($\frac{1}{4}$) of an inch.

26. LAYING. The bridgestones shall be laid in parallel courses separated by a corner of granite blocks, and shall be well and firmly bedded on a layer of sand spread on the foundation as prepared for the pavement. The transverse joints shall be broken by a lap of at least one (1) foot, and be so laid as not to be parallel to vehicular traffic.

27. **BLOCKS.** The blocks to be used shall be of a durable, sound, and uniform quality of granite, each stone measuring not less than eight (8) inches, nor more than twelve (12) inches in length; not less than three and one-half ($3\frac{1}{2}$) nor more than four and one-half ($4\frac{1}{2}$) inches in width, and not less than seven (7) nor more than eight (8) inches in depth, and the stones shall be of the same quality as to hardness, color, and grain. No outcrop, soft, brittle, or laminated stone will be accepted. The blocks are to be rectangular on top and sides, uniform in thickness, to lay closely, and with fair and true surfaces, free from bunches. Over special constructions, the blocks may be of dimensions other than above specified, when approved by the engineer. The stone from each quarry shall be piled and laid separately in different sections of the work, and in no case shall the stones from different quarries be mixed.

28. **PAVING CEMENT.** The paving cement to be used in filling the joints between and around the paving blocks and bridge-stones when laid on concrete, as hereafter provided, shall be composed of twenty (20) parts of refined asphalt and three (3) parts of residuum oil, mixed with one hundred (100) parts of coal-tar pitch such as is ordinarily numbered four (4) at the manufactory, the proportions to be determined by weight. The paving cement must be heated as needed for immediate use.

29. **SAND.**—On the concrete foundation, as designated, shall be laid a bed of clean, coarse dry sand to such depth (in no case less than one and a half [$1\frac{1}{2}$] inches), as may be necessary to bring the surface of the pavement, when thoroughly rammed, to the proper grade.

30. **LAYING.** On this sand bed, and to the grade and crown specified, shall be laid the stone blocks at right angles to the line of the street or at such angle as may be directed. Each course of blocks shall be laid straight and regularly, with the end joints by a lap of at least three (3) inches, and in no case shall stone of different width be laid in the same course except on curbs. All

joints shall be close joints except that when gravel filling is used, the joints between courses shall be not more than three-quarters ($\frac{3}{4}$) of an inch in width.

31. ON SAND FOUNDATION. As the blocks are laid they shall be covered with sharp, coarse sand, free from gravel, which shall be raked or brushed until all the joints become filled therewith; the blocks shall then be thoroughly rammed to a firm, unyielding bed, with a uniform surface to conform to the grade and crown of the street. It shall be covered with a good and sufficient second coat of clean, sharp sand, and shall immediately thereafter be thoroughly rammed until the work is made solid and secure; and so on until the whole of the work shall have been well and faithfully completed. No truck or vehicle shall be allowed to pass over it until the final ramming has been completed as above, but no ramming shall be done within twenty feet of the face of the work that is being laid.

32. ON CONCRETE FOUNDATION. After the blocks are laid on a concrete foundation, they shall be covered with a clean, hard, and dry gravel, which shall have been artificially heated and dried in proper appliances, placed in close proximity to the work, the gravel to be brushed in until all the joints are filled therewith to within three (3) inches of the top. The gravel must be washed white quartz and be entirely free from sand or dirt and must have passed through a sieve of five-eighth ($\frac{5}{8}$) inch mesh and been retained by a three-eighth ($\frac{3}{8}$) inch mesh.

33. RAMMING. The blocks must then be thoroughly rammed and the ramming repeated until they are brought to an unyielding bearing with a uniform surface, true to the given grade and crown. No ramming shall be done within twenty (20) feet of the face of the work that is being laid.

34. TEMPERATURE OF PAVING CEMENT. The boiling paving cement, heated to a temperature of 300 ° Fahrenheit, and of the composition hereinbefore described, shall then be poured into the joints until the same are full, and remain full to the top of the

gravel. Hot gravel shall then be poured along the joints until they are full flush with the top of the blocks, when they shall again be poured with the paving cement till all voids are completely filled.

35. The appliances for heating paving cement shall be sufficient in number and of such efficiency as will permit the pourers to closely follow the back rammers, and all joints of the finally rammed pavement shall have been filled with paving cement as above noted, before the cessation of the work for the day or any other cause.

36. **MORTAR BED BY CAR TRACKS.** On either or both sides of the rails of car tracks, as may be designated, the contractor shall lay on the concrete foundation adjacent thereto a bed of Portland-cement mortar, of the quality hereinbefore set forth, one of cement to three of sand, in which long and short blocks, alternating and tothing into the pavement as headers, shall be bedded.

37. This mortar bed shall extend outward from the rail to a width of four (4) inches beyond the outer edge of the long blocks, and it shall not be prepared for or laid to an extent greater than fifteen (15) feet in advance of the pavers, and before laying, the concrete shall have been first thoroughly swept and wetted.

38. **THICKNESS OF MORTAR BED.** The top of concrete shall be at such elevation and the mortar bed shall be of such thickness (in no case less than $1\frac{1}{2}$ inches) that when the paving blocks are therein embedded, there shall remain 1 inch of mortar under the stones, their top surface shall be $\frac{1}{4}$ of an inch above the tread of the adjacent rail (except at guards or other projections when they will be flush with the latter) and the bottom of the stones shall be locked in position by the displaced mortar rising in the joints.

39. No ramming of tothing stones shall be allowed and they shall be set carefully to grade, with joints filled and poured as above, and be properly protected until the mortar is set.

40. NO CARTING ON PAVEMENT. No horse, cart, truck, or vehicle of any description shall be permitted to stand on, or pass over, the pavement until the joints have been finally poured with cement as above and the same has had time to harden, and, by car tracks, the contractor shall furnish men to pass cars there-over.

41. When each section of the street has been completed, travel is to be allowed thereon, if required by the engineer, and at the time of completion of the entire work and before the final payment, the contractor will be required to make good at every point any defect which is the result of non-compliance with any of the provisions of this contract.

In case of repairs it shall be required that such repairs be made with a pavement equal to the above described.

42. APPROACHES. The curbstones, crosswalks, and gutters of the adjoining pavements and all pavements abutting the new work shall be readjusted and brought to the new grades and lines to the extent deemed necessary by the engineer, and such readjustment of curb and pavement shall include rejointing, resetting, and relaying as hereinbefore provided, at the prices stipulated.

43. CLEARING UP. All surplus materials, earth, sand, rubbish, and stones, except such stones as are retained by order of the engineer, are to be removed from the line of the work, block by block, as rapidly as the work progresses. All material covering the pavement and sidewalks shall be swept into heaps and immediately removed from the line of the work.

44. During the prosecution of the work the contractor shall keep the footway clean by sweeping. When material is removed, the sidewalk must be immediately swept clean by the contractor, and when public or local inconvenience is caused by dust the contractor shall water any piles or surface of earth or the sidewalks, or pavement foundation during sweeping when and where necessary or whenever required by the engineer to do so.

CHAPTER VIII

BRICK PAVEMENTS

RECORDS seem to indicate that the first pavements of brick to be used in the United States were laid about 1870 in Charlestown, W. Va., and in several of the smaller towns of the Middle West where clay is plentiful. In Holland, however, brick had been employed for such purposes as early as the thirteenth century, and is still extensively so used. Recently its use in the smaller towns and in localities where clay is abundant has been quite extensive, and the many superior characteristics which a brick pavement possesses, particularly for light traffic, warrants its choice. The popularity of this form is indicated by the United States Report for the decade ending with 1900. During that period, of the hard pavements laid 33 per cent were of brick; this being exceeded only by asphalt with 43 per cent, and followed by granite block with 10 per cent, wooden block 9 per cent, and miscellaneous 5 per cent. The latest report of the United States Census Bureau, that for 1903, regarding pavements shows that in cities of over 25,000 inhabitants, of the hard pavements in place 31 per cent was of asphalt, 25 per cent of granite block, 19 per cent of brick, 14 per cent of wooden block, and 11 per cent of cobble, but this is hardly indicative since in towns of less than 25,000 brick is much more generally used than in towns exceeding this population.

The advantages of brick as a paving material may be enumerated as follows:

- (1) It affords a good foothold.
- (2) It materially reduces the tractive force.
- (3) The pavement is fairly durable under moderate traffic.

- (4) It is not noisy.
- (5) It is easily cleaned, and therefore sanitary.
- (6) It is easily repaired.
- (7) It requires no expensive plant, and hence good for small towns.

Generally speaking, "it seems to be able to withstand misuse in construction, especially in the less heavily travelled streets of the smaller communities, better than any other paving material, and as a consequence is one of the most popular materials for this class of towns. In the larger cities, where pavements are more scientifically constructed, brick is also popular, not only because in them it is better laid, but it has a smoother surface and is less slippery than most other hard pavements."

The figures which follow, taken from a report on street paving by J. W. Alvord, 1903, show graphically two reasons for the preference for brick pavements.

One demonstrates the relative loads that may be hauled (on the various pavements) with the same expenditure of energy, and in this respect brick is placed first. The other shows the relative amount of labor required to clean the various pavements, and here again brick takes lowest place, being equalled, but not exceeded, in economy of cleaning by asphalt and rectangular wooden block. On the other hand, brick is extremely likely to be lacking in uniformity, both as to shape and quality, unless great care is exercised in the manufacture, and in consequence wears unevenly.

The Brick. A paving brick differs from an ordinary building brick both in shape and physical characteristics. It is larger, harder, tougher, less porous, and stronger in every way than the latter. Generally speaking, the same conditions that govern the selection of size in granite block for paving should determine that of a brick, but there are certain factors in the manufacture that preclude these dimensions being used. "If the brick is made too long, it is liable to warp either in the preliminary drying

or while being burned in the kiln. If it is too thick, so that the clay in the interior is vitrified with difficulty, it is probable that when sufficient heat has been applied to insure the proper vitrification to the central part of the brick, the outside will have been damaged and the brick not of uniform texture throughout, so

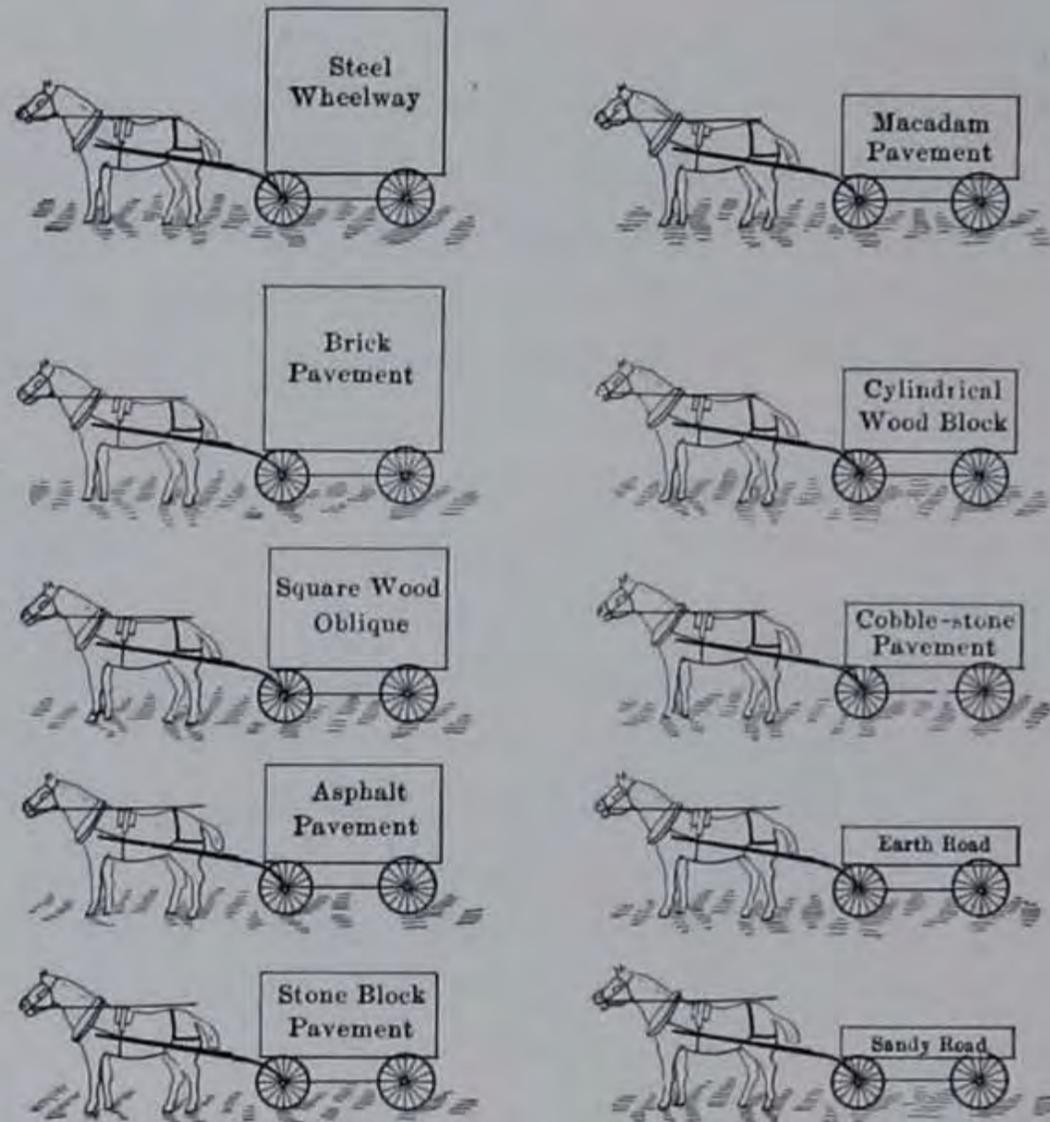

FIG. 57.

that in determining the thickness the same rule will not apply to all clays, as some clays will vitrify more readily than others."*

The above, a few minor reasons and experience, have led manufacturers and engineers to select bricks for paving of the two following sizes: $2\frac{1}{2}$ ins. \times 4 ins. \times $8\frac{1}{2}$ ins. and 3 ins. \times 4 ins. \times 9 ins., the latter being termed blocks. Formerly this uniform-

* Tillsen.

ity in size did not exist, and it has been only after years of experience and experimenting with various shapes and sizes that the above dimensions have resulted.

The form of the brick is, without exception, rectangular. In cases the edges are rounded off; in others, square. Some bricks will have a groove in them to hold the joint filler, while others will have a small button on each side to keep the bricks apart and provide a joint for the filler.

It is claimed for the rounded edges that there is no tendency for the corners to be worn or chipped off by horses' hoofs, as is the case with square edges, leaving the bricks rough and the joints uneven. But, on the other hand, it is maintained by the advocates of square-cornered bricks that if the filling of the joints is properly inserted between the bricks, and if of suita-

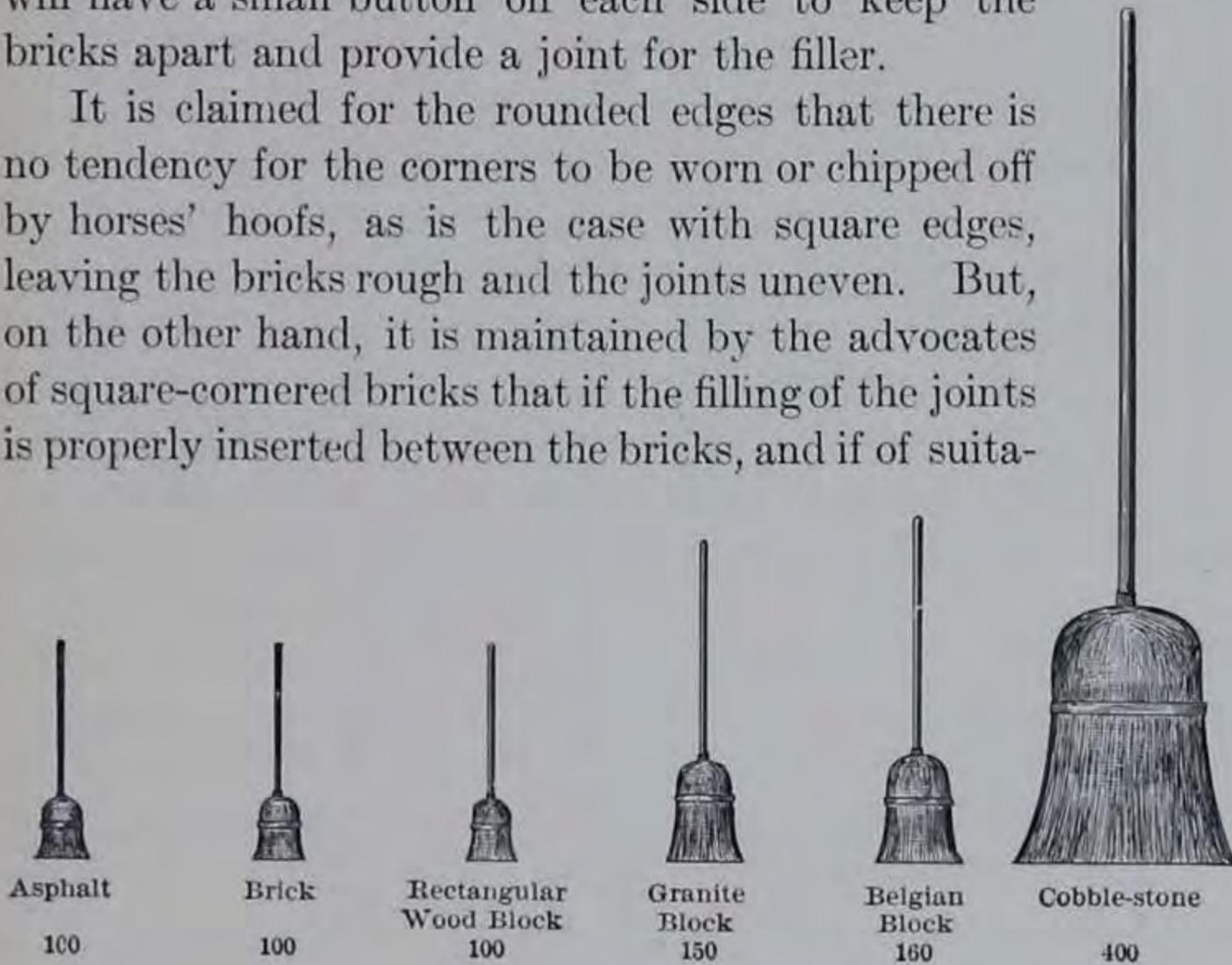

FIG. 58.

ble material, no such tendency will exist with the square edges. It would seem to be more a question of choice rather than positive advantage of one over the other. Grooved bricks are supposed to have the advantage of retaining more of the filler that goes between the joints, while the projections on the sides of other forms maintain a constant distance between bricks, and thus permit of the filler being inserted. The grooves are about one-eighth inch deep, while the buttons are about the same

distance. In the latter case it is very questionable practice, since under all circumstances joints should be made as narrow as possible. Because of the variability in the character of paving bricks, precautions in the form of tests have been uniformly adopted to determine the quality of the material that is being offered. Good paving bricks should be hard, tough, strong, homogeneous, impervious to water, and dense, and the following tests are supposed to indicate to what degree the brick possesses these qualities.

Hardness. This quality may be determined by the ordinary hardness test, *i.e.*, the ease with which a material is scratched by certain other materials, according to some scale; or the color may be taken as an indicator, though the latter requires experience and judgment, and even then is not absolute. The hardness is supposed to indicate the degree with which the material will withstand the abrading action of the horses' hoofs and wagon wheels; and an average hardness of six in Moh's scale is required.

Moh's Scale.

1. Talc, common laminated, light-green variety.
2. Gypsum, crystallized variety.
3. Calcite, transparent variety.
4. Fluorite, crystalline variety.
5. Apatite, transparent variety.
6. Orthoclase, white cleavable variety.
7. Quartz, transparent.
8. Topaz, transparent.
9. Sapphire, cleavable variety.
10. Diamond.

Toughness, or the ability to resist the pounding of the rapid blows from horses' hoofs, is equally important with the foregoing. These two characteristics are determined by what is known as the standard Impact and Abrasion Test.

Impact and Abrasion Test. "(1) **DIMENSIONS MACHINE.** The standard machine shall be 28 ins. in diameter and 20 ins. in length, measured inside the rattling chamber. Other machines may be used varying in diameter between 26 ins. and 30 ins., and in length from 18 ins. to 24 ins.; but if this is done, a record of it must be attached to the official report. The rattler may be cut up into sections of suitable length by the insertion of an iron diaphragm at the proper point.

"(2) **CONSTRUCTION OF THE MACHINE.** The barrels shall be supported on trunnions at either end. In no case shall the shaft pass through a rattler chamber. The cross-section of the barrel shall be a regular polygon having 14 sides. The head staves shall be composed of gray cast iron, not chilled or case-hardened. There shall be a space of $\frac{1}{4}$ in. between the staves for the escape of dust and small pieces of waste. Other machines may be used having from 12 to 16 staves, with openings, from $\frac{1}{4}$ to $\frac{3}{8}$ in. between staves; but, if this is done, a record of it must be attached to the official report of the test.

"(3) **COMPOSITION OF THE CHARGE.** All tests must be executed on charges containing but one make of brick or block at a time. The charge shall consist of 9 paving blocks or 12 paving bricks together with 300 lbs. of shot made of ordinary machinery cast iron. This shot shall be of two sizes, as described below, and the shot charge shall be composed of $\frac{1}{4}$ (75 lbs.) of the larger size and $\frac{3}{4}$ (225 lbs.) of the smaller size.

"(4) **SIZE OF SHOT.** The larger size shall weigh about $7\frac{1}{2}$ lbs. and be about $2\frac{1}{2}$ ins. sq. and $4\frac{1}{2}$ ins. long with slightly rounded edges. The smaller size shall be cubes of $1\frac{1}{2}$ ins. on a side, with rounded edges. The individual shot shall be replaced by new ones when they have lost $\frac{1}{8}$ of their original weight.

"(5) **REVOLUTIONS OF THE CHARGE.** The number of revolutions of a standard test shall be 1,800 and the speed of rotation shall not fall below 28 nor exceed 30 per minute. The belt power

shall be sufficient to rotate the rattler at the same speed, whether charged or not.

“(6) **CONDITION AND CHARGE.** The bricks composing the charge shall be dry and clean, and as nearly as may be possible in the condition in which they were drawn from the kiln.

“(7) **CALCULATION OF THE RESULTS.** The loss shall be calculated in the per cents of weight of the dry brick composing the charge, and no result shall be considered as official unless it is the average of two distinct and complete tests made on separate charges of brick.”

Strength or Transverse Strength, a characteristic which every brick should possess so that it may be able to withstand the tendency to break which arises when the brick is unevenly supported on the foundation.

The following is the standard method adopted for this test:

“1. Support the brick on edge, or as laid in a pavement, on a hardened-steel knife rounded longitudinally to the radius of 12 ins., and transversely to the radius of $\frac{1}{8}$ in., and bolted in position so that the screw-span of 6 ins. applied to load in the middle of the top shall pass through the steel knife-edge, straight, longitudinally, and rounded transversely to a radius of $\frac{1}{16}$ in.

“2. Apply the load to the middle of the top face through a hardened-steel knife-edge, straight, longitudinally, and rounded transversely to a radius of one-sixteenth inch.

“3. Apply the load in a uniform rate of increase until fracture ensues.

“4. Compute the modulus of rupture by the formula

$$F = \frac{3WL}{2BD}$$

in which F = modulus of rupture in pounds per square inch; W = the total brick load in pounds; L = the length of span in inches, six; B = breadth of brick in inches; D = depth of brick in inches.

“ 5. Samples for test must be free from all visible irregularities of surface or deformities in shape, and their upper and lower faces must be practically parallel.

“ 6. Not less than ten bricks shall be broken, and the average of all is to be taken for the standard test.”

“ Cross-breaking test of paving brick is made for the following reasons:

“ 1. It furnishes the means of comparing the differences of various kinds of clay paving material.

“ 2. For any particular kind of brick it shows whether the brick has been properly treated in the various stages of its manufacture.

“ 3. It indicates the resistance of the material in cross-breaking when laid on beds of unyielding and uneven surface.

“ 4. The cross-section being exposed, the interior structure may be examined.”

The Crushing Strength of a brick is usually determined by taking one-half of the specimen that has been broken in the transverse test. This piece is placed upon the horizontal platform of the testing machine, and another parallel surface of steel held in the cross-heads of the machine is made to gradually approach. The power is kept constant so that the pressure applied increases until failure results. The total load applied to the specimen, divided by the measured horizontal area of the brick, will give the pounds per square inch that the material will withstand. To secure even-bearing surfaces, and hence prevent any inequality of bearing, blotting paper or pieces of leather are usually placed next to the surfaces of the brick. This secures an even distribution of the pressure.

Homogeneity. Each brick, taken as a unit, should be homogeneous in character to insure a uniform wear. If part of a brick is properly burned and the rest improperly burned, the former will resist the wear to a much greater extent than the latter, resulting in an unevenly worn brick. Each brick, there-

fore, should be perfectly and completely fused to secure a homogeneous unit.

Uniformity. This refers to all the bricks that may be used in one contract. It is required that the material itself shall be uniform, that the method of manufacture shall be identical, and that the resultant product shall be uniform in character. The purpose of this is that the pavement may wear evenly, as under such conditions the best results obtain. It is much better to lay a pavement of bricks that are uniformly soft in character than to construct one of bricks alternately hard and soft, which results in an uneven surface in a short time.

Imperviousness. All material for paving should be impervious, as otherwise it absorbs moisture and tends to disintegrate. A good brick should absorb no more than two per cent of moisture. It is not an important test, however, and not recommended as one to indicate the quality of a brick, as the results are misleading.

Density, or the specific gravity of a brick, is determined to indicate the relative amount of material in the specimens subjected to test. Other things being equal, the denser specimen, *i.e.*, the one with the greatest amount of material, should wear the longest.

$$\text{Sp. Gr.} = \frac{A}{BC}$$

A = weight of brick in air;

B = weight of brick in air saturated;

C = weight of brick in water;

average from 1.90 to 2.60.

FOUNDATION

Without a properly laid foundation irregularities quickly appear with consequent increased wear and tear to pavement and vehicles, together with an increase in the tractive force. The object to be attained with any foundation is to support the over-

lying covering, and particularly where brick is used must the top surface be maintained smooth and even.

Various forms of foundation have been employed upon which to place the brick, but there is no question but that the most satisfactory one is of concrete. Sand and gravel are not at all desirable. When either is employed, however, about 8 ins. is laid on the prepared subgrade, and carefully rolled with a 10 ton roller to procure consolidation. A cushion coat of sand 2 ins. in depth is placed beneath the brick, and a templet passed over it to shape the surface parallel to that of the pavement.

Sand alone as a foundation is pretty poor, as the wear becomes abnormal. It may be used, however, in connection with planking as a foundation, and with fairly satisfactory results. Under these conditions the sand is first laid to a depth of about 3 ins., and upon this are placed treated boards, 1 in. to 2 ins. thick, while on top of these again, a 1 to 2 in. cushion coat of sand is spread to receive the brick. The object of the cushion coat is to secure an equal bearing for all points of the under surface of the bricks, and this result is achieved through the fact that the sand conforms to the irregularities of the bottom surface. Such a foundation is only suitable to light traffic.

Another form employed where brick is cheap is a bottom layer of brick, laid flat on a bed of sand, which is rolled and rammed, brought to an even surface, and covered with a cushion coat of one inch or two inches to receive a top layer, set on edge. This is a quite common practice in the Middle West, where a stone foundation would be too expensive.

Where broken stone is used as the foundation, it is prepared by rolling until it has become well compacted and firm. Upon it is then placed the usual cushion coat, and above this the brick. The broken stone should be so well rolled and compacted that there is no danger of the sand of the cushion coat filtering into its interstices and leaving voids beneath the brick.

Concrete is without doubt the best foundation for brick, as it

is for every other pavement. The same conditions obtain here as for any other foundation of the same material. The only drawback to concrete is its expense, particularly where, as in some localities, stone of the proper character is scarce. The upper surface of the concrete should be smoothed off as much as possible when laid, and when set, the cushion coat of sand should be laid on top of it to take up any irregularities either in the foundation or the brick, and thus secure an even bearing.

JOINT FILLING

The purpose of the joint filling is to secure a watertight surfacing. Many materials have been used with varying success, but the more popular and common are cement grout and paving cement.

This cement-grout filler is composed of one part cement and one part sand, or of neat cement alone. When the former is used, the sand and cement are thoroughly mixed dry, and water then added till the proper consistency is reached. The grout is applied by spreading it over the pavement, and sweeping it into the joints until it appears flush with the upper edges of the brick, while upon this is spread a thin surfacing of fine sand. During this part of the construction and until the cement has set traffic is excluded from the thoroughfare.

The principal advantages of such a filler are that it is watertight and, furthermore, being hard and tough, resists the wear and tear of traffic to an equal extent with the brick, thus preventing their edges from chipping, which is not the case with other forms of joints. Its disadvantage is that it in no way provides for the expansion of the pavement in hot weather, in consequence of which rumbling may be caused due to the fact that the brick draws away from the foundation, leaving a hollow space between.

To overcome this, however, expansion joints may be placed at intervals, both longitudinally and transversely, along the pavement. Such joints consist of either tar or asphalt, are from $\frac{1}{2}$

in. to 1 in. wide, and are placed next each curb to take up the expansion due to rise in temperature. Transversely the joints are spaced about 40 to 60 ft. apart, or else the expansion is allowed for by filling 2 or 3 consecutive joints at stated intervals with the prescribed mixture.

Tar filler has some of the advantages of the cement grout, besides others of its own, but its disadvantages are more serious than the latter. Such a filler produces a watertight joint, and allows for the expansion of the pavement in hot weather; but, on the other hand, it is too soft to protect the edges of the brick from chipping, in extreme warm weather it melts and runs, while in cold weather it becomes brittle and is easily chipped into fragments, to be removed by one means or another.

The tar used is a No. 5 or No. 6 coal-tar distillate, while asphalt may be added or used alone to secure a filler not so easily affected by temperature. It is applied hot, being poured into the joints until it appears flush with the surface, and on top of this spread the usual coat of sand which is worked into the joints by brooming and later by traffic.

Sand as a filler is often used, but as it possesses the disadvantage of allowing water to percolate through to the foundation, it is not entirely satisfactory. Where it is used, it should be perfectly dry and fine, and when applied to the pavement should be well broomed into the joints with enough left on the surface, about one-half inch, for traffic to continue the operation.

LAYING THE BRICK

After the foundation has been properly prepared, a cushion coat of sand one inch to two inches deep is spread uniformly over it, and to secure the proper crown a wooden templet is moved over the sand from one end of the section to be paved to the other. This templet is constructed of several pieces of board with the under surface conforming in outline to the desired transverse grade. If the street is comparatively narrow, the templet

is built for the entire cross-section, the ends rest upon the curbs, and the whole is drawn along over the sand. Where the street is wide, however, a templet is built for the one-half section, and is used by resting one end on the curb and the other on a strip of lumber placed along the centre of the street.

In laying the brick the precaution is always taken to leave the sand undisturbed, and to accomplish this the pavers stand or kneel only on those bricks that have already been laid. Each course is started at the curbs so that it shall break joints with the two adjacent courses, and when a course has been completed it is keyed up with an iron bar so that the last brick may be inserted. The courses should be kept perpendicular to the axis of the street, to accomplish which they are "trued up" every four or five feet.

After laying, the pavement is rolled with a steam roller until the bricks have reached an even-bearing surface and no longer move under the action of the roller. Or, if this is not feasible, planks are laid parallel to the curb and rammed by a heavy rammer. It is not advisable to lay the plank across the street and ram, as it is then likely to cause an uneven settlement.

While it is the more usual custom to lay the brick in lines perpendicular to the axis of the street, they are sometimes arranged herringbone fashion. There is no particular advantage in this except that in the street itself no joints are parallel to the line of traffic, while it has a decided disadvantage since "between the streets it brings the line of cross joints lengthwise to the travel of the street, which permits a weak spot in the pavement, and at intersections it brings a great many of the bricks lengthwise of the traffic turning the corners."

INTERSECTIONS

The following figures (Figs. 58 and 59) show two methods of laying brick at the intersection of streets, the general purpose of which forms of construction is to reduce the wear and afford at all points a good foothold.

In Fig. 58, wagons turning from one street to another follow a line which is at all points approximately perpendicular to the length of the brick, which is the best condition for both wear and foothold, while when crossing the street in a straight line, the direction of traffic is diagonal to the length of brick; and which,

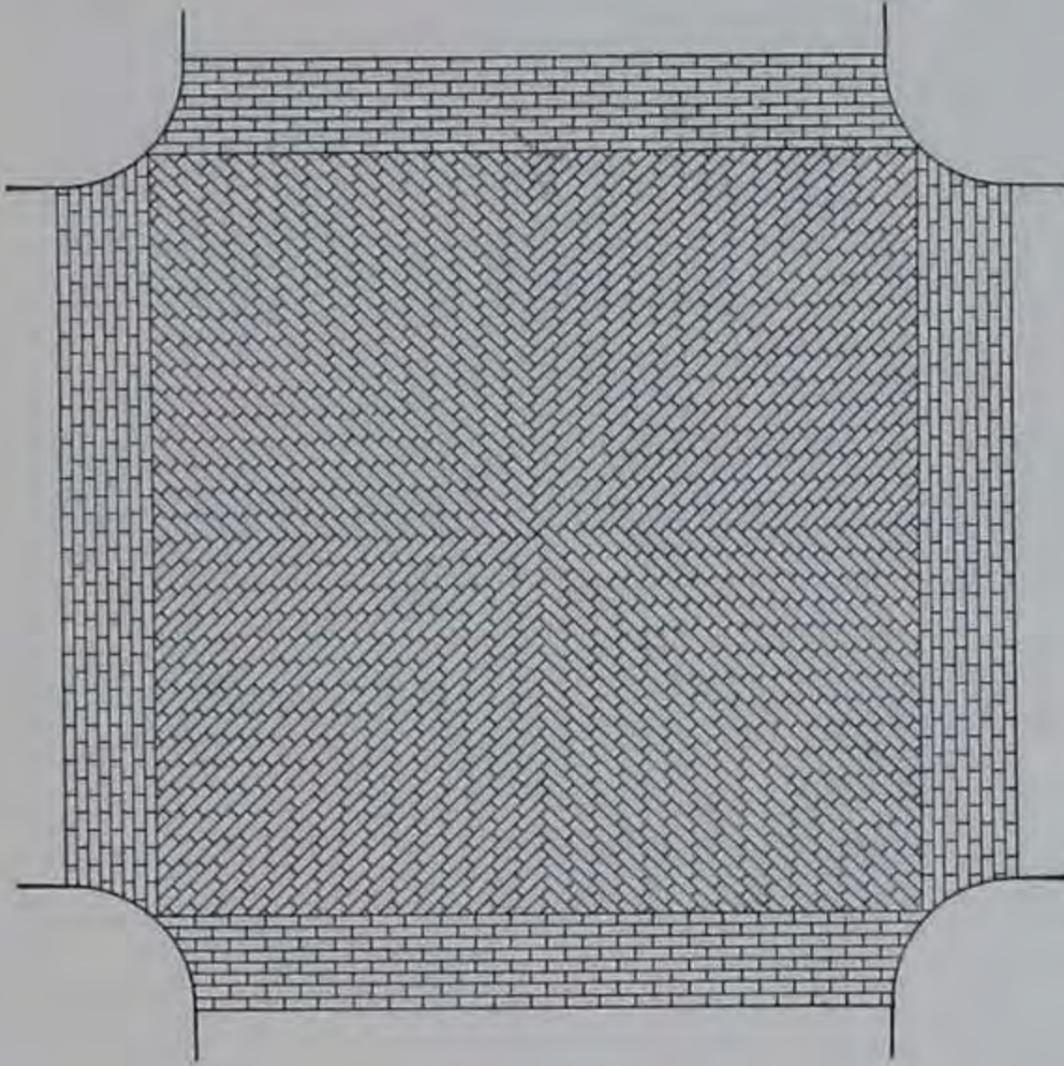

FIG. 58.

in the opinion of some, is supposed to be a condition superior to any other.

Few wagons will travel along the courses of the bricks and none for any considerable distance, which is the most objectionable direction as regards uniformity of wear. The weak lines are at the junctions of the four rectangles which are in the middle of the streets. These can be laid so carefully and with such good foundation that they will give no trouble. Careless laying will cause unequal settlement, which will have greater effect along

these lines than in the regularly laid pavement. Special care should, therefore, be taken at intersections.

Fig. 59 shows another method of placing the brick at intersections, which is more easily laid than the other; besides which careless workmanship has not nearly so great an effect

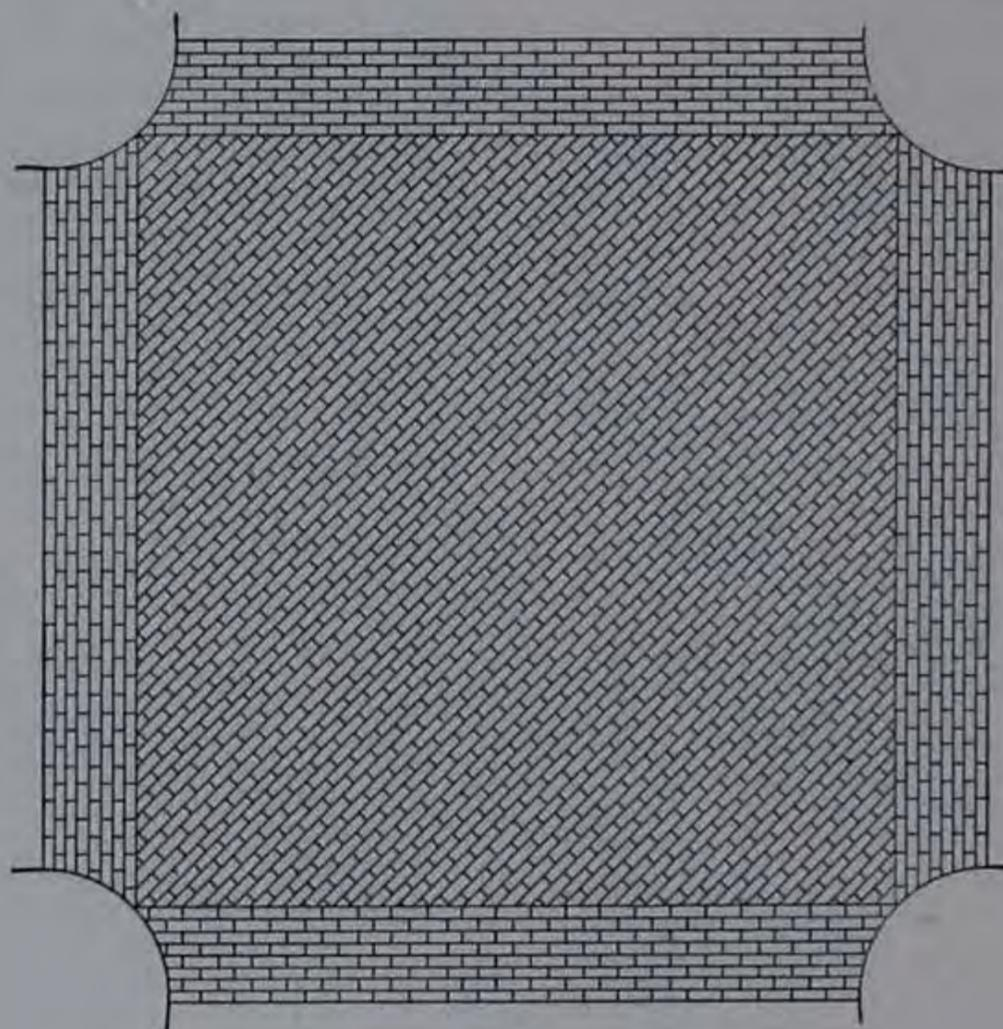

FIG. 59.

upon it. With good labor the former is the superior, because in the latter under two conditions traffic is travelling along the length of the brick in turning corners, thus causing unequal wear.

The following "Directions for Laying Vitriified Brick Street Pavements" indorsed and recommended by the National Paving Brick Manufacturers' Association, contains such valuable material that it is submitted in full.

“ DIRECTIONS FOR LAYING VITRIFIED BRICK
STREET PAVEMENTS ”

Form Two. Specification One. Best Known Construction—
Concrete Base Cement Filler

SECTION 1. SUBSTRUCTURE OR GRADING.—Earth in excavation to be removed with plough and scraper, or other device, to within two (2) inches of subgrade, then brought to the true grade with the roller, the weight of which should be not less than five (5) nor more than eight (8) tons. If the earth is too hard to receive compression through the roller, then loosen the remaining inches with a pick and cart away.

Earth in embankment must be applied in layers of eight (8) inches in thickness and each layer thoroughly rolled, and in both excavation and embankment the subgrade must have a uniform density.

If the underground is spouty clay, tile drainage should be provided to carry off this accumulation of wet.

REASONS WHY

The attempt to remove earth to the proper depth or grade line with plough and scraper is usually fatal to the general surface of the subgrade, for the reason that no man can hold a plough, or team draw the same to a straight grade; therefore in an attempt to get too close to subgrade with a plough, holes will be gouged below the true grade. When the shovellers commence the removal of the ploughed earth, they will invariably sink these same low places still lower, and when the finishing begins these low places will necessarily have to be filled and compacted with the roller. Then you have different characters of solidity, which are objectionable and detrimental to good work.

The prime reason for not using a roller weighing more than eight (8) tons is that they are too cumbersome and unwieldy and very slow moving, while with a lighter and quicker moving one

you pass many times over the subgrade and get better results in having your subgrade more uniformly compacted.

The filling with loose earth of portions of the work that is below grade will be found necessary very often if an attempt is made to plough too close to the grade line, then the lighter roller is found more effective in bringing such places to the same density as the undisturbed portion.

When embankment is necessary to bring the street to the required grade line, it is very obvious that the earth should be deposited in equal layers of not more than eight (8) inches thick, and each layer thoroughly rolled. A six or eight ton, or even a heavier roller, will have little effect in compression below eight inches, and all embankments should be compacted as thoroughly as possible before applying the superstructure; for earth once disturbed and removed from its natural bed takes a long time to acquire its original solidity, the scientific reason for which would take too much space and time to enter upon here.

Underdrainage is not absolutely essential, but in wet and spouty understratum much is added to the durability of the structure by keeping the subfoundation dry, and under foregoing wet conditions underdrainage is the only way to accomplish the best results

SECTION 2.—CURBING.—Stone curbing should all be hauled and distributed and set before the grading is finished, and may then be used as a guide to finish the subgrade.

It should range in thickness from four (4) to six (6) inches, twenty (20) to thirty-six (36) inches wide, the business and street traffic governing the same, and lengths not shorter than four (4) feet, except at closures, neatly dressed on top with a square or rounded edge, and four (4) inches down on the inside. The outer surface to be tool-dressed to the depth of the face exposed and to the depth of the thickness of the brick and sand cushion. If cement concrete curb is used, it should be completed before the work of finishing the subgrade begins.

Curb corners of streets and alleys should be made circular.

EXTRA MENTION

If concrete curb and gutter is used, it must be placed in position before any of the other work is commenced, except, possibly, some of the heavier grading, and it is essential, if natural stone curb is used, to have it all in place before any portion of the grading is finished, for the reason that, after you have finished a subgrade and given it the proper contour and surface it should never be disturbed by unnecessary wheelage, and nothing destroys it so effectually as hauling heavy stone curb over it; and in renewing these broken places they are rarely returned to the original conditions.

The curb should all be set before the finishing of the subgrade begins, if for no other reason than that it affords the very best guide for the said finishing.

MARGINAL CURB

SECTION 3.—MARGINAL CURB.—Should always be of a hard and durable character of stone, and from fourteen (14) to eighteen (18) inches deep, dressed on top, and five (5) inches down on the face next to the brick, set accurately to fit the curvature of the cross-section of the street on six (6) inches of concrete and backed up with the same within six (6) inches of the top.

EXTRA MENTION

Marginal curb should always be of a hard and durable character of stone (hard wood is better than soft stone), and set on and backed up with a good Portland-cement concrete, mixed in the proportion of 1 to 2 to 4.

Marginal curb is, as a rule, used to sustain a paved street against one that is unpaved; therefore the reason it should be well and properly set, and unless it is, the impact of the wheelage

in passing from the unpaved to the paved street will soon drive it down and loosen it if not firmly and securely set, and in a short time the pavement begins to break and give way and will continue to do so for quite a distance into the intersection.

Even with the marginal curb set in the above manner there should be a margin of crushed stone or clean gravel to the width of three or four feet and eight (8) or ten (10) inches deep spanning the width of the opposing unpaved street and tamped firmly against the marginal curb. With these precautions you will avoid the rapid destruction of the margin of your paved streets.

SECTION 4.—CONCRETE FOUNDATION.—Should be of approved quality of hard rock, free from all refuse and foreign matter, with no fragment larger than will pass through a two (2) inch ring, and no smaller than will pass through a one (1) inch ring in their longest dimensions.

Clean, sharp, dry sand thoroughly mixed in its dry state with an approved brand of either hydraulic or Portland cement until the whole mass shows an even shade. If hydraulic, the proportion of mixture should be 1 part of cement and 2 parts of sand. If of Portland, 1 part of cement to 3 parts of sand.

To the above mixture should be added sufficient clean water to mix to a plastic mass, fluid enough to rapidly subside when attempted to heap into a cone shape. To this mixture add four (4) and six (6) parts, respectively, of damp crushed stone, or good gravel carrying sufficient sand to make the mixture, and then turn the whole mass over not less than three (3) times, or until every fragment is thoroughly coated with the cement mixture. For the reception of this mixture, the grade should be set off in five foot squares, with a stake at each corner. Tops of each should be at the surface of concrete, which must be tamped until free mortar appears on the surface. Occasional sprinkling in extra hot, dry weather is beneficial. After thirty-six hours the cushion sand may be spread.

EXTRA MENTION

If the combination of gravel and sand is used the mixture for natural cement should be one (1) measure of cement to six (6) measures of the mixture. If Portland cement, one (1) measure of cement to eight (8) measures of the mixture.

There is but one way to make good cement mixtures, presuming, of course, you have good material, and that is to thoroughly mix the dry materials. It is essential that the sand and cement should be thoroughly incorporated in their dry state; if not then it can't be done after the water is applied. In the first, you will have a homogeneous mass; in the second, a heterogeneous. In the one your mixture is complete and your structure is uniform; in the other, it varies and your structure is uncertain. The above applies especially to platform mixing. In machine manipulation the dry mixing isn't so readily obtainable, but could be more nearly approached if greater care were taken. Thorough mixing in both dry and wet state, with good material and proper proportions, insures a good concrete, whether it be of crushed stone or gravel.

SECTION 5.—SAND CUSHION.—Sand should be clean and free from foreign or loamy matter. It need not necessarily be sharp. It should be two (2) inches thick before the compression of the brick by rolling. The sand should be spread by the aid of a template the whole or one-half the width of the street, and made to conform with the true curvature of the street cross-section.

EXTRA MENTION

The preparation of the subgrade having been, with care, brought to a true plane as to curvature and grade, and to a uniform thickness, the work is ready for the cushion for the brick, for which any good clean sand may be used, whether it be sharp or spherical; but it is next to the impossible to spread it satisfactorily with a template or in any other manner when

it is wet, and if you insist on your pavement maintaining its symmetrical form the sand must be evenly spread; and there is but one method for doing this, and that is mechanically, by the aid of a template, formed to fit the curvature of the street and armed with small metal wheels at either end, rolling on the curb at one end and on a 4×4 in. scantling laid lengthwise through the centre of the street at the other.

If the roadway of the street isn't to exceed twenty-five (25) feet in width or less, the template can be made to span the entire width, both ends rolling on the curb.

This manner insures an even thickness of sand over the surface of the concrete, giving to each individual brick a like thickness of cushion, so that when the brick surface is rolled each brick will present the same resistance to the pressure of the roller, and you will then perforce have a smooth surface; otherwise, if the sand is of uneven thickness the tendency of those bricks resting on the thicker bed of sand is to sink, under the pressure of the roller, lower than those resting on a thinner layer, and the result is an undulating and uneven surface.

BRICK

SECTION 6.—BRICK. The brick should all be hauled and neatly piled within the curb line before the grading is finished, or, if allowed by the engineer, delivered in wagons and carried from the pile or wagon on pallets with clamps—not wheeled with barrows. In hauling from car no throwing or dumping is allowed. They should be first-class and thoroughly vitrified, showing at least one fairly straight face; if the edges are rounded the radius should not be greater than $\frac{3}{16}$ of an inch. They should not be less than $2\frac{1}{4} \times 4 \times 8$, or more than $3\frac{1}{2} \times 4 \times 9\frac{1}{2}$ ins., free from cracks, with but slight lamination, and at least 1 edge with but slight kiln marks allowed, and should stand the tests promulgated by the National Brick Makers' Association.

EXTRA MENTION

It is not only good practice to have all of the brick hauled and distributed just inside the curb line before the work of grading begins on any street block, but it is economy, as experience has taught us that it is very expensive to attempt to get brick into a block after the other work has begun. Each side of the street should have the required number of brick neatly ricked up to lay to the centre of the street, thereby always maintaining the minimum distance to carry the brick to the setter.

In order to get the brick to the setter with the least possible abrasion or injury to the same, it is best to carry them on pallets, and so deposit them that the person laying them in the street will deposit them perfect edge up. No wheeling or teaming should be permitted over the brick at any stage prior to opening the same to the public.

BRICK-LAYING

SECTION 7.—BRICK-LAYING. Brick may be laid either at a right angle or an angle of forty-five degrees to the curb, as the engineer may direct, and in either way the line or course of brick must be kept straight or within a maximum variation of two inches; if greater than that, as many courses as necessary should be taken up and relaid until the defect in alignment is removed.

No parts of brick should be allowed in the pavement except the beginning or ending of courses or other closures. The brick must be laid with the best edges exposed as near in contact as possible; they must be closely inspected before laying and also after laying and after rolling. All soft brick, and those badly spalled or ill-shapen, must be removed and replaced with perfect ones. The kiln-marked ones may be turned over, and if the reverse edge is smooth and no other faults be found, they can remain in the pavement.

EXTRA MENTION

As to the alignment of the courses of the brick there is but little choice, either way is admissible without comment. The brick should be as nearly in contact as it is possible to lay them, for when the rolling is in progress, if there is appreciable space between the brick in the compression and bedding into the cushion sand, the brick will have a tendency to rock, and instead of receiving a flat foundation, as they should, it will be in a curved form, made by the rocking of the brick as the roller passes on and off them, and the pavement will require more grout to fill the interstices.

It isn't bad practice, if the gutter gradient is very flat, to lay five or six longitudinal courses parallel with the curb as there will be less hindrance to the gutter drainage.

SECTION 8.—ROLLING AND TAMPING. After the brick in the pavement are inspected and the surface is swept clean of spalls, they must be well rolled with a five (5) ton steam roller in the following manner: The brick next the curb should be tamped with a hand wood tamper to the proper gutter grade. The rolling will then commence near the curb at a very slow pace and continue back and forth until the centre of the pavement is reached, then pass to the opposite curb and repeat in the same manner to the centre of the street. After this first passage of the roller the pace may be quickened and the rolling continued until each brick is firmly embedded in the sand cushion. *The roller shall then be started at the end of the block and the pavement rolled transversely at an angle of forty-five degrees to curb, repeat the rolling in like manner in the opposite direction.* Before this transverse rolling takes place all broken or injured brick must be taken up and replaced with perfect ones.

EXTRA MENTION

There is no question open to discussion as to the virtue of a steam roller on a brick pavement. It is very necessary in

order to give it a smooth surface. The transverse rolling is very necessary in order to remove the slight wavy condition of the surface extending laterally from curb to curb, which will occur after the longitudinal rolling, and is the result of the thrust or impact occasioned by the propelling power of the roller. If the roller was drawn instead of being propelled these apparent waves would not occur. Therefore, the transverse rolling will practically remove them. The longitudinal rolling should always be from curb toward the centre. The curved transverse section of the street has a tendency to move the brick endwise toward the curb; therefore, under the pressure of the roller, if you start the roller in the middle and roll toward the curb the gutter bricks that you have previously tamped to grade will be very much disturbed and your flow line will require re-tamping. If it were practicable to use the roller absolutely against the curb the rolling might be done from the centre to the curb.

SECTION 9.—EXPANSION CUSHION. An expansion cushion must be provided for, one inch in thickness next to the curb, filled two-thirds of its depth with pitch, the top one-third being filled with sand.

EXTRA MENTION

This pitch joint next to and along the curb answers two purposes, it takes up the expansion of the brick and prevents a possible cracking of the pavement through and along the centre of the street, which sometimes occurs if the ends of the courses of the brick are abutted directly against the curb, which acts as a skewback or haunch to the arc of the pavement, which is often strong enough (especially if the sidewalk is up to and against the inside of the curb) to resist the force of expansion in that direction, and it will find relief in raising the pavement and the cracking mentioned above may occur. And again, in taking up the expansion the brick are kept in contact with the

sand cushion below, thereby preventing the rumbling noise so often heard, and occasioned wholly through lack of contact.

The inch of sand on the top of the pitch joint has a tendency to prevent the pitch from flowing, which it is likely to do in very hot weather. It is essential that the board occupying the place to be filled with pitch remain in place until after the street is in all other respects finished, but always withdrawn and the pitch applied within thirty-six hours after the application of the cement filler.

SECTION 10.—THE FILLER. The filler shall be composed of one part each of clean sand and Portland cement. The sand should be dry. The mixture, not exceeding one-third bushel of the sand together with a like amount of cement, shall be placed in the box and mixed dry, until the mass assumes an even and unbroken shade. Then water shall be added, forming a liquid mixture of the consistency of thin cream.

From the time the water is applied until the last drop is removed and floated into the joints of the brick pavement, the same must be kept in constant motion.

The mixture shall be removed from the box to the street surface with a scoop shovel, all the while being stirred in the box as the same is being thus emptied. The box for this purpose shall be $3\frac{1}{2}$ to 4 ft. long, 27 to 30 ins. wide, and 14 ins. deep, resting on legs of different lengths, so that the mixtures will readily flow to the lower corner of the box, which should be from 8 to 10 ins. above the pavement. This mixture, from the moment it touches the brick, shall be thoroughly swept into the joints.

Two such boxes shall be provided in case the street is twenty feet or less in width; exceeding twenty feet in width, three boxes should be used.

The work of filling should thus be carried forward in line until an advance of fifteen to twenty yards has been made, when the same force and appliances shall be turned back and cover the

same space in like manner, *except* to make the proportions *two-thirds Portland cement and one-third sand*.

To avoid the possibility of the thickening at any point, there should be a man with a sprinkling can, the head perforated with small holes, sprinkling gently the surface ahead of the sweepers.

Within one-half to three-quarters of an hour after this last coat is applied and the grout between the joints has fully subsided and the initial set is taking place, the whole surface must be slightly sprinkled and all surplus mixture left on the tops of the bricks swept into the joints, bringing them up flush and full.

After the joints are thus filled flush with the top of the bricks and sufficient time for evaporation has taken place, so that the coating of sand will not absorb any moisture from the cement mixture, one-half inch of sand shall be spread over the whole surface, and in case the work is subjected to a hot summer sun, an occasional sprinkling, sufficient to dampen the sand, should be followed for two or three days.

EXTRA MENTION

Dry, sharp sand for this mixture is necessary without question or comment.

The first application should be thin in order that it may flow to the depth of the joints of the bricks, thereby insuring a substantial bond, and should be kept in constant motion while being applied; otherwise the sand will settle and you will have water and cement instead of water, sand, and cement. The water and cement wouldn't be objectionable, but the sand by itself is wholly so.

It must also be mixed in small quantities, as it is next to impossible to keep the sand in suspension when more than a common water pail of each, sand and cement, is used, and unless it is deposited upon the pavement with the sand in combi-

nation with the solution you will get the cement and water in the lower portion of the joints between the bricks and the sand without the cement in the upper portion. If you could get the sand in the lower, and the cement in the upper portion of said joints, you would have a good grouted street. Some one, some day, may perfect a mechanical device for doing this satisfactorily, but at this time no such method is known. The rocking trough has been tried for the mixing and discharging, but invariably the cement will flow out first, then follows the sand to fill the upper parts of the joints; therefore, the safest way is to use the scoop shovel as the specifications direct.

Ten days is the minimum time for keeping the street blocked and free from traffic. Thirty days would be better, and longer if it were possible. In testing-laboratories the usual

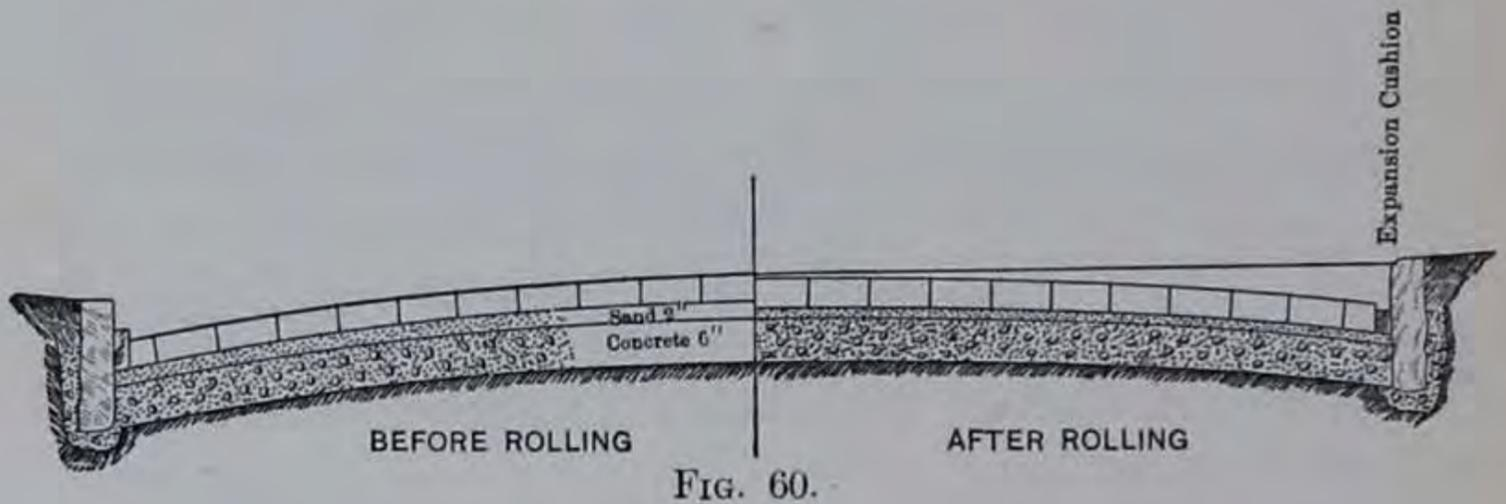

time for allowing cements (neat cements at that) to stand before applying the tests, is twenty-seven days. Therefore, when you open a grouted street to traffic in ten days you are demanding and expecting more from the cement than any testing-laboratory would, so the streets should remain closed as long as a suffering public will permit.

It is urgently insisted that in no case shall the proportion of cement be lessened.

Grouting thus finished must remain absolutely free from disturbance or traffic of any kind for a period of ten days

at least. The specifications, closely and skilfully followed, will give you the three important factors of a desirable city thoroughfare—DURABILITY, COMFORT OF TRAVEL, PERFECT SATISFACTION.

The foregoing are some of the many reasons why the above instructions for brick street building should be embodied in all specifications by the authorities.

CHAPTER IX

ASPHALT PAVEMENTS

“ASPHALT is a term which may be used industrially or specifically; industrially, to cover all solid native bitumen (*i.e.*, all solid native, natural hydrocarbons) used in the paving industry; and specifically, to include such as melt on the application of heat at about the temperature of boiling water, are equally soluble in carbon bisulphide and carbon tetrachloride, and to a very large extent in eighty-eight degrees naphtha, consisting to a very considerable degree of saturated hydrocarbons yielding about fifteen per cent of fixed carbon and containing a high percentage of sulphur.”

An asphalt pavement is one in which the principal and distinguishing, though not the largest, constituent of the wearing surface is asphalt.

Asphalt may be distinguished by the following characteristics:

- Sp. Gr. = 0.96 to 1.68.
- Color = dark brown to glittering black.
- Hardness = liquid to 3½ Dana Scale.
- Streak = brown to brownish black.
- Fracture = dull to conchoidal.
- Odor = bituminous.

Insoluble in H₂O, soluble in carbon bisulphide, alcohol, turpentine, ether, naphtha, and petroleum. Before the blow pipe it melts quickly, evaporates, and burns, leaving no ash.

Chemically, when pure, asphalt contains:

C = 80 to 88 per cent
 O = 0.5 to 10 per cent
 H = 9 to 11 per cent
 N = 0 to 1 per cent

Asphalt is found in a liquid, semi-liquid, or solid state, or else impregnating the sandstones or limestones. In the former state it is always mixed with water together with some organic and inorganic impurities, and for this reason it becomes necessary for it to undergo a refining process during the course of which the water and volatile oils are driven off and the organic impurities gotten rid of. It does not matter so much about the inorganic impurities or mineral matter contained within the asphalt, since under all conditions it is necessary to add some such constituent to the latter to form the wearing surface.

The material mostly used in the United States for paving purposes comes from the island of Trinidad off the north coast of Venezuela, South America, or from the province of Bermudez in Venezuela, the former being known as Trinidad, and the latter as Bermudez asphalt.

In the crude state they contain the following constituents:

	Trinidad Per Cent	Bermudez Per Cent
Water and gas.....	29	
Organic matter not bitumen.....	7	1.5 to 9
Mineral matter.....	25	1.5 to 3
Bitumen.....	39	89.2 to 97

It will be seen from this that the Bermudez asphalt is very much purer than the Trinidad, consisting of nearly pure bitumen. The bitumen itself analyzes as follows:

	T.	B.
C.....	82.33	82.88
H.....	10.69	10.79
S.....	6.16	5.87
N.....	0.81	.75
	<u>99.99</u>	<u>100.29</u>

The refined asphalts have the following:

PHYSICAL CHARACTERISTICS

	T.	B.
Sp. Gr.—at 78° F., original substance dry.....	1.40	1.05
Color of powder.....	blue black	black
Lustre.....	dull	bright
Structure.....	homogeneous	uniform
Fracture.....	semi-conchoidal	uniform
Hardness, original substance.....	2	soft
Odor.....	asphaltic	soft
Softness.....	180° F.	160° F.
Flows.....	190° F.	170° F.
Penetration at 78° F.....	7°	26°

CHEMICAL CHARACTERISTICS

Dry Substance.

Loss 325° F., 7 hrs.....	1.1 per cent	4.4 per cent
Character of residue.....	smooth	4.4 per cent
Loss 400° F., 7 hrs. (fresh sample).....	4 per cent	9.5 per cent
Character of residue.....	blistered	shrunk
Bitumen soluble in CS ₂ , air temp.....	56.4 per cent	96.0 per cent
Organic matter insoluble.....	6.7 per cent	2.0 per cent
Inorganic or mineral matter.....	36.9 per cent	2.0 per cent
	100.0 per cent	100.0 per cent

Asphalts from Maracaibo, Cuba, Mexico, and California differ somewhat from those mentioned above; but they are found in such limited quantities, however, that they have little commercial value. The evaporation of a petroleum oil with an asphalt base will also yield a residue like the native asphalts, the supply coming mostly from California and Texas, where such oils are found; but the process of manufacture requires such care and skill that most of the product, up to the present, is hardly satisfactory. The distinguishing characteristic between this and the native asphalts is that the latter contain mineral matter, while the former do not.

In Kentucky, Tennessee, Texas, Utah, and California impreg-

nated sand and limestones are found in considerable quantities, but they are hardly ever so satisfactory for paving purposes as the artificial material. The natural limestones make the harder but more slippery pavement, while the sandstones frequently have too little bitumen in them to hold the sand grains together.

Asphalt pavements may be classified as follows: Natural, as opposed to artificial-asphalt pavements; and sheet, as opposed to block pavements.

Natural-asphalt pavements may be either in the sheet or block form, consisting of a wearing surface of the naturally impregnated stone. In this country the natural pavement is used to some extent, and where so used preference seems to be given generally to the sandstones rather than the limestones, as they wear more evenly, do not polish, and thus afford greater advantages to traction and as regards the foothold. On the other hand, the limestones are very much more durable. Abroad the asphaltic limestones are much more abundant than the sandstones, and consequently much more generally used.

Both will contain about the same amount of bitumen, however; that is, the limestones are made up of 88 per cent carbonate of lime with 12 per cent of bitumen, while the sandstones contain from 7 to 13 per cent of the latter constituent.

Where natural sand rock impregnated with asphalt is used, the pavement is constructed as follows. *First*, the sand rock itself is ground, and it is then heated to a temperature of 300° F. and spread on a clean, concrete base, rolled and rammed to a thickness of two inches. No flux is used with the sand rock, as the bitumen present is found to be quite cementitious enough and no binder course is found necessary. Sometimes this sand is mixed with limestone rock in the proportion of 1 to 1 or 2 to 1, depending upon the amount of bitumen present.

Such natural pavements have been found eminently satisfactory in Buffalo, where they cost annually but $\frac{1}{2}$ to $\frac{1}{3}$ in repairs of what the artificial pavements do.

Artificial-asphalt pavement is a name applied to one in which the wearing coat consists of a mixture of sand, limestone or silica dust, and asphaltic cement, which constituents are artificially commingled. The sand is for the purpose of taking the wear the same as the naturally impregnated sandstones or limestones, while the asphalt performs the function of cementing these particles together in exactly the same way as is done naturally in the sandstones and limestones. The function of the limestone or silica dust is to fill the voids between the sand grains and thus save the expensive material.

ARTIFICIAL PAVEMENTS are built either in the sheet or block form, and in America at least are the much more satisfactory pavement.

The principal advantages of an asphalt pavement, whether sheet or block, natural or artificial, are that,

- (1) It reduces tractive force.
- (2) It is impervious.
- (3) It is easily cleaned.
- (4) It is durable.
- (5) It is noiseless.
- (6) It produces no dust or mud,

while its disadvantages are,

- (1) It is slippery under certain weather conditions.
- (2) It is affected to some degree by heat or cold, the former softening it and causing it to wave, while the latter will produce cracks.
- (3) It is not especially good on heavy grades.
- (4) It is expensive.
- (5) Excessive moisture disintegrates it.
- (6) It must have an absolutely unyielding foundation, as otherwise it is easily broken down.

An asphalt pavement consists of three essentially different parts: 1st, the foundation; 2d, the binder course; and 3d, the wearing surface.

THE FOUNDATION

The foundation is a particularly important factor in the case of asphalt pavements, as asphalt in itself possesses no resistance to crushing and simply performs the function of taking up the wear. If the foundation hence is not absolutely unyielding, the asphalt will have no power to counteract this lack of strength, and the pavement will soon be filled with depressions that are quickly converted into holes by the action of traffic and the disintegrating effects of moisture collected therein.

At present the most popular and most satisfactory foundation for asphalt pavements is a hydraulic concrete. This is made of natural or artificial cement, in the proportions of 1 cement to 2 sand (4-6 broken stone) or 1 cement to 3 sand (5-7 broken stone), and varies in depth, depending upon the nature of the subsoil, amount of traffic, etc., etc., from 4 ins. to 6 ins.

With a concrete base it has been found that the surfacing is apt to strip off rather easily, but while this is an advantage as regards the matter of repairs, it is a disadvantage in the fact that the surface is not so firmly held to the foundation, and in consequence the former is apt to roll and crack under extremes of temperature.

Concrete is, under nearly all circumstances, the best foundation, for it forms an impervious covering for the subsoil and possesses great strength. When the street has never before been paved, concrete is always selected for these reasons.

It has frequently occurred, however, that "much of the sheet asphalt in the great cities has been put directly upon old pavements of cobbles or of stone blocks, of which the depressions may be filled with hot crushed stone sprinkled with hot asphaltic cement, or which may be merely reset at points of subsidence to restore the regular form, but which are usually reset at three inches lower grade and with the proper crown in order to make

room for the 'binder' and 'wearing surface' of asphalt without having to raise the manholes, car tracks, and curbs. The joints between the stones of the old pavements should be three-quarters of an inch wide and should be brushed and cleared for at least an inch in depth to afford a firm hold for the 'binder.' In some instances, stone blocks for a base have been relaid flat to give a lower grade, but this is not good practice and has given poor results unless there is a concrete base beneath the old blocks."

"Brick pavement and macadam have been successfully used as a foundation for asphalt, but it is found difficult to restore the pavement to its original good condition when cuts have to be made for pipes of any kind."

Where concrete is employed, care should be taken to see that the material has thoroughly set before the asphalt is applied, and before the binder is put on all moisture should be removed from the surface by a sponge or application of heat, as its presence prevents a good bond between binder and foundation.

THE BINDER

The binder is the name given to the mixture of stone and asphalt cement which is placed next the foundation, and upon which the wearing surface proper is laid, and whose function it is to bind the two together.

The stone used is any hard tough rock which has been crushed to a size of one and one-quarter inches or less, and usually contains some of the coarser screenings of the sand. Ninety-five per cent by weight of stone and five per cent of asphalt cement are the proportions used, though this amount of cement will vary depending upon voids. The mixture of cement and stone should be thorough, and so complete that every fragment is completely covered with the cement.

The binder is brought hot to the place from the mechanical mixer and spread, by means of rakes, to a depth of about two inches over the concrete foundation, and then rolled by a steam

roller until the thickness has been reduced to one and one-half inches.

The surface of the binder course should be made parallel to the finished coating, and must be so firm that it is not displaced by the passage of teams.

WEARING SURFACE

The topmost layer of an asphalt pavement, that is, the wearing coat, is composed of sand, limestone or silica dust, and asphaltic cement.

- 80 per cent sand.
- 10 per cent asphaltic cement.
- 10 per cent stone dust.

THE SAND, constituting about 80 per cent of the wearing surface, should be hard, clean, sharp, and have few voids. This is the material that really takes the wear while the asphalt simply binds the grains together. The greater resistance to wear and crushing hence possessed by the sand the longer the life of the pavement. If the grains are sharp and angular, there will be a good mechanical bond similar to that existing in broken stone, and if the voids are few there will be less need of the other materials, *i.e.*, the stone dust and asphalt, to fill these voids; and it will hence require less of the expensive material asphalt to bind the whole together, thus reducing the cost of the pavement. The size of the grains should vary so as to diminish the amount of voids as much as possible.

THE STONE DUST may be either limestone or silica, and its function is more completely to fill the voids between the grains of sand. The proportion of stone dust to sand depends upon the percentage of voids in the sand, and the relation must be determined by trial, as the best ratio is when the combined sand and stone dust yield the smallest percentage of interstices.

To determine this ratio varying amounts of stone dust are mixed in a pail with a constant quantity of sand and the resulting voids ascertained by pouring in enough water to flush the surface

of the mixture. That combination requiring the least amount of water is the most satisfactory as then less asphalt is needed. Necessarily this will vary with the nature of the sand, but usually from 5 to 15 per cent of dust is needed.

This stone dust should be so fine that all of it will pass a 30 mesh, per linear inch, sieve, and 75 per cent pass a 100 mesh sieve.

In regard to the use of carbonate of lime or silica dust it would seem that the latter is more satisfactory, as it is the less slippery and is not soluble in rain water containing CO_2 gas.

THE ASPHALT

The asphalt or asphaltic cement consists of refined asphalt mixed with a flux or softening agent. The refined asphalt is the crude asphalt with water and volatile oils driven off, and to this is added the flux which varies in character, but has the property of reducing the brittleness or hardness of the refined asphalt to form the asphaltic cement which possesses the binding properties in the surface coat. The fluxes should possess the following properties:

“ (1) Contain a material volatile under 300° F. as otherwise the volatile matter will be given off while the paving cement is being heated preparatory to its being mixed with the sand of the wearing coat, and consequently the asphalt will lose its cementing power.

“ (2) The flux should be as fluid as possible in order that the greatest softening effect may be produced by the least quantity, as ordinarily the fluxing agent is comparatively expensive.

“ (3) The softening agent should be chemically stable, and not lose its fluidity by molecular change.

“ (4) The fluxing agent should dissolve the asphalt, and not simply form a mechanical mixture with it. The asphalt consists of asphaltine and petroline; the former being entirely devoid of cementing power, and the latter highly cementitious; and hence the fluxing agent should dissolve the asphaltine.”

The fluxes themselves are petroleum residuum, maltha, which is a liquid bitumen, and the asphaltic oils; and the amount to be used will vary both with the flux and the nature of the refined asphalt. It is a question which is best.

The thickness of the wearing surface is about 2½ ins., 2 ins. after rolling, for heavy traffic, and 1½ ins., compressed, for light traffic.

The wearing coat is brought to the place hot, at a temperature of about 280° F. and laid and spread with hot rakes to a depth of 2½ ins. and rolled till only 1½ ins. or to a depth of 3½ ins. and rolled till only 2 ins. This latter is the better thickness, particularly for heavy traffic.

The surface of wearing coat is first rolled with a 1,200 lbs. hand roller, which is cold, and which is constantly wiped with oily cotton waste to prevent the adhesion of any of wearing coat. Hydraulic cement is then swept over the surface to give a gray color to it and prevent adhesion, when a 5 ton roller is used for the final compression. This rolling will require 1 hour to every 60 × 30 = 1,800 sq. ft.

GRADE AND CROWN

“The actual steepest grades existing in various cities are shown in the accompanying table, in order that those having doubts in any extreme case may examine some of these grades and observe the results.

ACTUAL GRADES OF SHEET ASPHALT

City and State.	Ft. per 100 ft.	City and State	Ft. per 100 ft.
Buffalo, N. Y.....	5.1	Pittsburg, Penn.	17
Erie, Penn.	5	Salt Lake City, Utah	5
Grand Rapids, Mich.	7	San Francisco, Cal.....	16
Hartford, Conn.	5	St. Joseph, Mo.	8
Marion, O.....	5.75	Scranton, Penn.	13
New York, N. Y.	5	Syracuse, N. Y.	7
Omaha, Neb.	8	Toledo, O.	5
Peoria, Ill.	7.2	Troy, N. Y.	7.5

"The crown used in various cities on level streets is shown in the same way; it being borne in mind that the least crown which will shed water makes the best road for those who use it."

ACTUAL "CROWN" OF SHEET ASPHALT

City and State.	Inches per 30 ft. width bet. curb.	City and State	Inches per 30 ft. width bet. curb.
Albany, N. Y.	5	Jackson, Mich.	4½
Atlanta, Ga.	5	Joliet, Ill.	5
Binghamton, N. Y.	5	Mansfield, O.	5¼
Buffalo, N. Y.	5	Meriden, Conn.	4¼
Charleston, S. C.	4	Milwaukee, Wis.	11
Columbus, O.	6	Muncie, Ind.	12
Dayton, O.	4½	New Orleans, La.	5
Detroit, Mich.	3¾	Peoria, Ill.	6
Elmira, N. Y.	4½	Sandusky, O.	6
Erie, Penn.	6	Scranton, Penn.	5
Fort Wayne, Mich.	4	Springfield, Mass.	3½
Grand Rapids, Mich.	6	St. Paul, Minn.	5½
Harrisburg, Penn.	5	Terre Haute, Ind.	7
Hartford, Conn.	4½	Toronto, Ont.	7
Houston, Tex.	6	Troy, N. Y.	5½

Where street-railway tracks exist on an asphalted street, it is usually customary to place some other material than asphalt next the rail to permit of wagons turning into or out from the track without damaging the asphalt and causing a shoulder as they inevitably would do were the asphalt used. In New York City granite blocks are placed between the rails and a header and stretch next the rails on the outer side. Stone or brick is often used.

Where, as in some of the larger cities, such as Buffalo, a heavy rail of 90 lbs. with a large web 9 to 10 ins. is used, with welded joints and a concrete base, it is feasible to lay the asphalt close up to the rail.

BLOCK ASPHALT

This is formed of about 13 per cent asphaltic cement, 10 per cent limestone dust, and 77 per cent crushed gneiss, trap, basalt, or other hard rock. Basalt is usually preferable.

The material is heated to 300 ° F. in a rotary mixer until all

the particles have become perfectly coated with the limestone dust and cement and then moulded into blocks 12 ins. × (4 to 5 ins.) × (3 to 4 ins.) by a pressure of 2½ tons per sq. in.; and finally cooled in water.

The advantages of this sort of pavement are:

- (1) It may be laid in cold weather.
- (2) No skilled labor required.
- (3) Requires no plant, hence good for small towns.

But it is not so good as the sheet form. Has cracks, hence not so impervious, not so clean, not so noiseless. The best base is concrete, but it is sometimes laid on gravel covered with sand.

Below are given the complete specifications for both sheet and block-asphalt pavements.

SPECIFICATIONS

For Regulating, Grading, and Paving or Repaving with Asphalt Pavement on a Concrete Foundation the Roadway of

 From
 To
 together with all work incidental thereto.

1. EXTENT OF WORK. The work shall consist of regulating and grading the entire street (or if the street is already paved, of removing or readjusting the old pavement), setting and resetting curb, laying sidewalks where required, and laying asphalt pavement and all work incidental thereto, all in accordance with the plans and specifications on file in the office of the Bureau of Highways.

2. OBSTRUCTIONS. The contractor shall remove at his own expense, when directed by the engineer, any encumbrances or obstructions on the line of work, located or placed there prior to or after its commencement.

3. CATCH-BASINS, MANHOLE HEADS, ETC. Such catch-basins,

manhole frames and heads for sewers, water pipes or other conduits belonging to the City on the line of the work, as may be designated, shall be reset to the new grades and lines by the contractor without extra charge therefor, and they shall be brought to such grades with brick masonry of the same thickness as that originally used, laid in hydraulic cement mortar.

4. NOISELESS MANHOLE COVERS. Asphalt-filled noiseless covers, complete, for water and sewer manholes of the design approved by the engineer, shall be furnished and set wherever directed by the engineer. They shall be made according to general details to be furnished to the contractor and of such size as will fit the present manhole heads. The old covers to remain the property of the City.

5. REMOVAL AND OWNERSHIP OF OLD MATERIALS. All old material which will not be used in the work, excepting bridge-stone and specification paving stone, shall become the property of the contractor and be removed by him; the remainder, as specified above, shall be delivered when required, and piled in such corporation yard or elsewhere as the engineer may determine, and all at the expense of the contractor.

6. PREPARATION OF FOUNDATION. When the old material has been removed, that to be used again shall be compactly piled on the side and the roadway graded to the required shape and depth below the proposed finished pavement. All unsuitable material shall be removed and replaced with that which is satisfactory. Whenever deemed necessary by the engineer, the subgrade shall be rolled by a suitable steam roller.

7. RELAYING STONE PAVEMENT. When the present pavement is specified as a foundation, any and all portions thereof unfitted for the purpose by reason of grade or otherwise shall be taken up and relaid as may be directed, and for such purpose the materials necessary to be removed shall be piled or disposed of as heretofore specified.

8. On the roadbed graded and prepared as hereinbefore set

forth, the stones shall be relaid at right angles to the line of the street. They shall be well bedded on gritty earth or other material approved by the engineer, with surface joints not exceeding one (1) inch, the joints to be brushed full of the same material and the stones rammed to a solid, unyielding foundation, with their top surface parallel to and three (3) inches below the surface of the pavement to be laid. Such additional stones as may be required shall be supplied by the contractor without charge therefor.

9. INSPECTION AND PILING OF MATERIAL. The material for construction when brought upon the street shall be neatly piled so as to present as little obstruction to travel as possible. No material shall be used without having been first inspected and accepted by the engineer, the contractor furnishing all labor necessary for inspection without any charge. Should the work be suspended for any cause the materials shall be removed from the line of the work at the direction of the engineer, and unless so removed by the contractor upon notice from the said engineer, they will be removed by the president, and the expense thereof charged to the contractor.

10. CITY MONUMENTS. The contractor shall not excavate around such city monuments and bench-marks as may come within the limits of, or be disturbed by the work herein contemplated nearer than five (5) feet, or in any manner disturb the same, but shall cease work at such locations until the said monuments or marks have been referenced and reset or otherwise disposed of by the chief engineer of the Bureau of Highways. The necessary labor to remove, care for, and reset all such monuments and bench-marks shall be furnished without charge therefor by the contractor.

11. EXCAVATION AND GRADING. All material of every description—earth, rock, subsoil, vegetable or other matter, brick and stone masonry—overlying the subgrade hereafter described, shall be removed and the roadway and sidewalks freed from all

stones, and shaped as shown on plans. Excavations, of whatever character, shall extend fully to the lines specified on the plans. The cost of grubbing up and removing any trees, shrubbery, fences, timber, pipes, rubbish, or filth shall be included in the price bid for excavation.

12. The excavation shall be carried to the established grade and the sidewalks shall slope upward from the curb grades toward the house lines, all in accordance with the dimensions shown on the plan of the work and as the same are designated on the ground by the engineer. Should any soft, spongy, vegetable, or other objectionable matter be disclosed by the excavation thus made, or be located where filling is to be done, such material shall be removed and replaced with coarse sand, gravel, or other suitable material, which shall be thoroughly compacted, as hereinafter directed, at the price herein bid for earth excavation.

13. FILLING AND EMBANKMENTS. Embankments shall be brought up to the designated grades, and the top, shaped off and compacted as defined for earth excavation, shall extend fully to the lines and be maintained at the designated width and elevation until the expiration of the period of maintenance. Such excavated material as may be fit for the purpose and as may be necessary shall be used to fill in those parts of the street which are below the aforesaid grades, or which have become so by the removal of rock or improper material, in the manner hereafter provided, and the price paid per cubic yard of excavation is to include the cost of properly placing such excavated material as filling and in embankment, and the removal from the work of such as is not so utilized.

14. No excavated or other material necessary to be disposed of shall be dumped or placed within the limits of any existing or projected public street or road, nor shall any material be excavated and removed from such locations without the written permission of the engineer. When the material excavated, fit for filling, is insufficient in quantity to regulate the street, such

additional material necessary shall be furnished and placed by the contractor, and the quantity thereof to be paid for as "filling to be furnished" shall be the difference between the total amount of filling done or excavation made, with slopes in case as herein described, and to the grades shown on the cross-sections of the street.

15. The total amount of filling done will be determined by calculation, and will be only so much as is included between the elevation of said surface deposit, as recorded by the engineer, and the grades hereinbefore set forth (where such filling comes up to such grades) and no allowance will be made the contractor for any shrinkage, sinking, or settlement. All filling shall be good, wholesome earth, free from all frozen materials, garbage, vegetables, spongy or unsuitable matter.

16. CURBSTONE. Old curbstone which can be redressed to a top width of not less than four and one-half ($4\frac{1}{2}$) inches and not less than sixteen (16) inches deep and are of the quality hereafter specified, shall be redressed, rejointed, and reset as directed below.

17. QUALITY OF. New curbstones shall be free from seams and other imperfections and equal in quality to the best North-River bluestone. They shall be () inches in depth, and from three and one-half ($3\frac{1}{2}$) to eight (8) feet in length and not less than five inches in thickness, except as noted for bottom of curb.

18. HOW DRESSED. The face for a depth of nine (9) inches and the top on a bevel of one-half ($\frac{1}{2}$) an inch in its width of five (5) inches shall be dressed to a surface which shall be out of wind and shall have no depressions measuring more than one-quarter of an inch from a line or straight edge of the same length as the curbstone. The remainder of the face shall be free from projections of more than one-half an inch, and the back for three (3) inches down from the top shall have no projections greater than one-quarter of an inch measured from a plane at right angles to

the top. The bottom of the curb shall be rough-squared with a width of not less than three inches.

19. JOINTS OF. CURVED CURB. For the full width of the stone for a distance down of four (4) inches from the top, and therebelow, for a width of one and one-half inches back from the face to a point twelve (12) inches below the top of the curb, the ends shall be squarely jointed with no depression greater than three-eighths of an inch, measured from a straight edge. Curved curb corners shall be cut with true radial joints and be set accurately to such a radius as may be required in three (3) foot lengths. It shall be paid for as straight curb, and must comply in all respects with the above requirements therefor. The cost of excavation necessary for curb-setting shall be included in the price paid per linear foot of curb. The sample of the curbstone showing the dressing and the jointing required can be seen at the office of the chief engineer of the Bureau of Highways.

20. WHEN SET IN CONCRETE. Where the pavement is to be laid on concrete the curb shall be also set on concrete, as shown by detail on plan, and shall be set truly to line and grade on a face batter of one and a half inches in its depth.

WHEN SET ON SAND. When the pavement is to be laid on sand foundation the curb shall be firmly bedded in sand or fine gravel, and the space behind the curb to the top shall be filled with the same material thoroughly tamped. In either case each curbstone shall be set truly to line and grade on a face batter of one and one-half inches in its depth.

21. CHARACTER OF CONCRETE. The concrete foundation for curbstone shall be not less than six (6) inches thick and seventeen (17) inches in width, and be of the materials and proportions hereinafter described, except that the broken stone shall be not less than one-quarter ($\frac{1}{4}$) nor more than one and a quarter ($1\frac{1}{4}$) inches maximum dimensions; the curb shall be immediately bedded on the centre thereof, with a bearing for its full length as soon as the concrete is laid, and it shall be at once backed up with con-

crete for a width of six (6) inches, extending from the bottom bed to within four (4) inches of the top of the stone. The concrete so used will be paid for at the general price per cubic yard for concrete.

22. IN FRONT OF CEMENT WALK. When curb is set in front of a monolithic walk, the space between the curb and sidewalk foundation shall be completely filled with concrete similar to that described above, to within two (2) inches of the top; the remaining space to be filled with Portland cement of the quality hereinafter specified, mixed with an equal part of crushed stone used for wearing surface of such walks. Wherever curbstones, however set, shall have become displaced or damaged from any cause, such curbstone shall be reset or new ones shall be furnished in their place and no compensation therefor shall be allowed.

23. SIDEWALKS. On repaving work the first course of flagstones interfering with the work of curb-setting shall be taken up and relaid to the new curb grade, at the expense of the contractor. Any damage done by the contractor to sidewalks in curb-setting, handling, or in the storage of materials, shall be made good by him, at his own expense, as shall be directed by the engineer.

24. HOW LAID. All flagging to be relaid shall be firmly and evenly bedded to the grade and pitch required, on three (3) inches of steam ashes or sand free from loam or clay and the work brought to an even surface, with all joints close and thoroughly filled for the full depth with cement mortar composed of equal parts of the best Portland cement and clean, sharp sand, and left clean on the surface, and all earth, débris, and surplus material shall be removed from each block and the sidewalks swept clean as soon as the work thereon has been completed.

25. READJUSTMENT OF EXTERIOR FLAGGING. On an original improvement the contractor will be required to relay at his own expense any and all flagstones adjoining, but outside the limits of this work, which may require readjusting to conform to the new

grades and to replace with new flagstone any such removed stones which may be broken in handling or relaying, as well as all flagging necessarily removed in grading, unless a price is asked for the same.

26. QUALITY AND DIMENSIONS OF NEW FLAGGING. All new flagging shall be of bluestone of satisfactory and uniform color and equal in quality to the best North-River bluestone, and shall be free from sap, seams, flaws, drill holes, and discolorations. It shall have a smooth surface, be out of wind, and not less than three (3) inches thick at any point, and shall be five (5) feet in length and not less than two and one-half feet in width, except that wherever in sidewalks an old stone of superior dimensions is broken, but one new stone shall be put in its place, which must be in length and width not less than the old stone. New flagstone of smaller size shall be furnished when directed by the engineer, such stone to be of specification thickness and be used when necessary to match existing courses on walks already partly flagged and in the closure course of such walks as are to be flagged for the full width.

27. DRESSING AND CUTTING. All stones shall be chisel-dressed with opposite sides parallel and adjacent sides at right angles, on the four (4) edges a distance down of one (1) inch from top and at right angles thereto, and *such dressing shall be entirely completed before said stone shall be placed on the bed prepared.* Such further necessary dressing will be required that the stones may fit closely to circular corners and coping courses and around all gas lamps, posts, and poles of all descriptions, hydrants, water boxes, sewer manholes, basins, etc., and to give openings nine (9) inches square over city monuments and good and sufficient openings around all trees.

28. LAYING. All flagging shall be laid in regular courses five (5) feet in width, and shall be firmly and evenly bedded to the grade and pitch required, on three (3) inches of steam ashes or sand, free from clay or loam; the work to be brought to an even .

surface with all joints close and thoroughly filled for their full depth with cement mortar composed of equal parts of the best quality of Portland cement and clean, sharp sand, and left clean on the surface; but no more mortar shall be mixed at any one time than can be used within one-half ($\frac{1}{2}$) an hour, nor shall any mortar be laid against any edge of a stone until the stone to abut thereagainst shall have been completely dressed ready for laying.

29. PRICE TO INCLUDE. The price paid per square foot for new flagging shall include the furnishing of the new stone and all work incidental to and including its laying as above described.

30. FLAGGING TO BE RELAID. Where a price is asked for relaying old flagstones, all such existing stones which shall be considered by the engineer suitable for relaying, or which, though broken, may be recut to an acceptable size, shall be pitched on the four edges to true lines, care being taken to get a joint as nearly at right angles as possible to the upper surface of the stone and free from feather edges, and be relaid in front of the property where found; the stone to be completely dressed before being laid on the bed prepared.

31. REMOVAL OF FLAGGING. No flagstone whatever shall be removed from its bed unless the said stone shall have been designated by the engineer for removal, and said engineer or inspector shall be present to examine its condition, and it shall be the duty of the contractor to notify the engineer whenever old flagging is to be lifted. All stones necessary to be removed shall be carefully lifted by barring under the exposed edge, and no barring between joints shall be permitted; those in the tail course interfering with the work of curb-setting shall be lifted clear and be set back. Flagstones, on being removed, shall be stood in piles according to size and be kept clear of other material (in front of the property where found), and when directed by the engineer the contractor shall remove off the work and not again re-employ thereon any employee found breaking or injuring old stone by carelessness in handling or otherwise.

32. **HEADING STONES.** Wherever the new pavement abuts pavement of a different character or an unpaved street, the contractor shall put down bluestone heading stones at least three (3) feet long and one (1) foot deep, and set with full bearing on a bed of concrete nine (9) inches wide and six (6) inches deep, of the quality hereinafter described. These heading stones shall be of good sound bluestone, free from lamination or seam; they shall be dressed square on top to a good surface, free from great irregularities, and to a uniform width of not less than four and a half ($4\frac{1}{2}$) inches. The ends shall be jointed square down to give close joints, and the bottoms shall be nowhere less than three (3) inches wide and be cut to give a full square bearing throughout, and the sides shall be free from bunches.

33. **CONCRETE.—CEMENT.—PROPORTION.** The concrete shall be made of the best quality of Portland cement, samples of which must be submitted at least ten (10) days (Sundays and holidays excluded) before using, for the inspection and approval of the chief engineer. All cement shall be a uniform quality, color, and weight, and briquettes of one (1) square inch section shall develop or exceed the following tensile strength:

Neat—four (4) hours in moist air, twenty (20) hours in water	200 pounds
Neat—one (1) day in air, six (6) days in water.....	400 pounds
One (1) of cement, three (3) of sand, one (1) day in air, six (6) days in water.....	150 pounds

The concrete shall be composed of one (1) part of cement, three (3) parts of sand, and six (6) parts of broken stone. The unit of measure shall be the barrel of cement as packed by and received from the manufacturer.

34. **SAND AND STONE.** The sand shall be clean, coarse, and sharp, and be free from loam or dirt. The broken stone shall be of trap, granite, or limestone or such other stone taken from the line of work as shall be satisfactory in the judgment of the engineer. It shall be entirely free from dust and dirt, and be of

graded sizes such that all will pass through a revolving circular screen having holes two and one-half ($2\frac{1}{2}$) inches in diameter and be retained by a screen having holes one-half ($\frac{1}{2}$) inch in diameter. The sand and stone shall be placed upon board platforms and be kept free from dirt, and the cement shall be properly blocked up and protected from dampness.

35. MIXING. The sand and cement shall be mixed dry, then made into mortar by the addition of water, when the broken stone shall be added and the whole mass thoroughly mixed. The concrete shall then be spread upon the subgrade and rammed so as to fill all the voids of the stone with mortar and bring the surface exactly three (3) inches below the finished pavement. If a machine be used for mixing, the above operation may be varied as may be required. No concrete shall be used that has been mixed more than one-half hour. The concrete shall be protected from the weather when deemed necessary by the engineer.

36. NO CARTING. No horses, carting, or wheeling shall be allowed on the concrete before the same has set, except on planks furnished and laid by the contractor.

37. THICKNESS. The concrete foundations shall be five (5) inches thick, except where otherwise specially ordered.

STONE PAVEMENTS

38. BRIDGESTONES.—QUALITY. When required, old bridge-stones shall be redressed, rejointed, and relaid as hereafter directed for new bridge-stones, and for such purpose shall be hauled to the necessary point or points by the contractor. Bridgestone broken by being so hauled, redressed, or relaid shall be replaced by the contractor at his own expense. New bridge-stones shall be of the same quality of granite as the blocks, free from all imperfections.

39. DIMENSIONS. They shall be eighteen (18) inches wide, of a uniform thickness, not less than six or more than eight inches in depth, and from three and one-half ($3\frac{1}{2}$) to eight (8) feet in

length, except that in special cases, between railroad tracks, they may be of such dimensions as may be approved by the chief engineer of the Bureau of Highways.

40. DRESSING. The top shall be dressed to a surface not varying in evenness more than one-quarter ($\frac{1}{4}$) of an inch. The sides and ends shall be dressed square down and the latter cut to a transverse bevel of six (6) inches in the width or to such other bevel as may be directed, and the jointing from top to bottom shall give joints not greater than one-quarter ($\frac{1}{4}$) of an inch.

41. LAYING. The bridgestones shall be laid in parallel courses separated by granite blocks, and shall be well and firmly bedded on a layer of sand spread on the foundation as prepared for the pavement. The transverse joints shall be broken by a lap of at least one (1) foot, and be so laid as not to be parallel to vehicular traffic.

42. BLOCKS. The blocks to be used shall be of a durable, sound, and uniform quality of granite, each stone measuring not less than eight (8) inches nor more than twelve (12) inches in length, not less than three and one-half ($3\frac{1}{2}$) nor more than four and one-half ($4\frac{1}{2}$) inches in width, and not less than seven (7) nor more than (8) inches in depth, and the stones shall be of the same quality as to hardness, color, and grain. No outcrop, soft, brittle, or laminated stone will be accepted. The blocks are to be rectangular on top and sides, uniform in thickness, to lay closely, and with fair and true surfaces, free from bunches. Over special constructions, the blocks may be of dimensions other than above specified when approved by the engineer. The stone from each quarry shall be piled and laid separately in different sections of the work, and in no case shall the stones from different quarries be mixed.

43. PAVING CEMENT. The paving cement to be used in filling the joints between and around the paving blocks and bridgestones when laid on concrete, as hereafter provided, shall be composed of twenty (20) parts of refined asphalt and three (3) parts of

residuum oil, mixed with one hundred (100) parts of coal-tar pitch such as is ordinarily numbered four (4) at the manufactory, the proportions to be determined by weight. The pitch, oil, and asphalt must be heated and mixed on the work in the proportions named, as needed for immediate use unless otherwise directed.

44. SAND. On the roadbed or on the concrete foundation, as designated, shall be laid a bed of clean, coarse dry sand to such depth (in no case less than one and a half [$1\frac{1}{2}$] inches), as may be necessary to bring the surface of the pavement, when thoroughly rammed, to the proper grade.

45. LAYING. On this sand bed, and to the grade and crown specified, shall be laid the stone blocks at right angles to the line of the street or at such angle as may be directed. Each course of blocks shall be laid straight and regularly, with the end joints by a lap of at least three (3) inches, and in no case shall stone of different width be laid in the same course except on curbs. All joints shall be close joints, except that when gravel filling is used the joints between courses shall be not more than three-quarters ($\frac{3}{4}$) of an inch in width.

46. ON SAND FOUNDATION. As the blocks are laid they shall be covered with sharp, coarse sand, free from gravel, which shall be raked or brushed until all the joints become filled therewith; the blocks shall then be thoroughly rammed to a firm, unyielding bed, with a uniform surface to conform to the grade and crown of the street. It shall be covered with a good and sufficient second coat of clean, sharp sand, and shall immediately thereafter be thoroughly rammed until the work is made solid and secure; and so on until the whole of the work shall have been well and faithfully completed. No truck or vehicle shall be allowed to pass over it until the final ramming has been completed as above, but no ramming shall be done within twenty feet of the face of the work that is being laid.

47. ON CONCRETE FOUNDATION. When the pavement is laid on a concrete foundation the blocks shall be covered with a clean,

hard, and dry gravel, which shall have been artificially heated and dried in proper appliances, placed in close proximity to the work, the gravel to be brushed in until all the joints are filled therewith to within three (3) inches of the top. The gravel must be entirely free from sand or dirt, and must have passed through a sieve of five-eighth ($\frac{5}{8}$) inch mesh and been retained by a three-eighth ($\frac{3}{8}$) inch mesh.

48. RAMMING. The blocks must then be thoroughly rammed and the ramming repeated until they are brought to an unyielding bearing with a uniform surface, true to the given grade and crown. No ramming shall be done within twenty (20) feet of the face of the work that is being laid.

49. TEMPERATURE OF PAVING CEMENT. The boiling paving cement, heated to a temperature of 300° Fahrenheit, and of the composition hereinbefore described, shall then be poured into the joints until the same are full, and remain full to the top of the gravel. Hot gravel shall then be poured along the joints until they are full flush with the top of the blocks, when they shall again be poured with the paving cement till all voids are completely filled.

50. The appliances for heating paving cement shall be sufficient in number and of such efficiency as will permit the pourers to closely follow the back rammers, and all joints of the finally rammed pavement shall have been filled with paving cement as above noted, before the cessation of the work for the day or any other cause.

51. TOOTHING CEMENT. When shown on the plans on either or both sides of the rails of car tracks, as may be designated, the contractor shall lay on the concrete foundation adjacent thereto a bed of Portland-cement mortar, of the quality hereinbefore set forth, one of cement to three of sand, in which long and short blocks, alternating and tothing into the pavement as headers, shall be bedded. This mortar bed shall extend outward from the rail to a width of four (4) inches beyond the outer edge of

the long blocks, and it shall not be prepared for or laid to an extent greater than fifteen (15) feet in advance of the pavers, and before laying the concrete shall have been first thoroughly swept and wetted.

52. The top of concrete shall be at such elevation and the mortar shall be of such thickness (in no case less than $1\frac{1}{2}$ inches) that when the paving blocks are therein embedded there shall remain at least one inch of mortar under the stone, the top surface shall be a quarter of an inch above the tread of the adjacent rail (except at guards or other projections, when they will be flush with the latter), and the bottom of the stone shall be locked in a position by the displaced mortar rising in the joints.

53. No ramming of tothing stones shall be allowed, and they shall be set carefully to grade, with joints filled and poured as above, except that smaller joints and finer gravel may be used when deemed best by the engineer. These tothing stones shall be properly protected until the mortar is set.

54. Whenever granite blocks are laid in connection with an asphalt pavement the work shall be done in accordance with the above specifications.

ASPHALT PAVEMENT

55. DEFINITION. The pavement proper shall consist of a binder course one (1) inch in thickness and a wearing surface two (2) inches thick and equal to the pavement mixture hereinafter described. Before laying binder, the surface of the foundation shall be thoroughly swept and cleaned, and all dirt and fine particles removed from the joints of blocks to such a depth as may be directed by the engineer.

56. BINDER COURSE. The binder shall be composed of suitable clean broken stone passing a one-and-a-quarter ($1\frac{1}{4}$) inch screen, not more than ten (10) per cent of which shall pass a No. 10 screen.

57. STONE. The stone shall be heated in suitable appliances,

not higher than 325° Fahrenheit, and then thoroughly mixed by machinery with asphaltic cement equivalent in composition to that hereinafter set forth, at 300° to 325° Fahrenheit, in such proportion as shall be acceptable to the engineer.

58. LAYING. The binder must be hauled to the work and spread while hot upon the foundation to such thickness that, after being immediately compacted by ramming and rolling until it is cold, its depth shall be at no place less than one (1) inch, and its upper surface shall be parallel to the surface of the pavement to be laid. Upon this binder course must be laid the wearing surface or pavement proper.

59. PAVEMENT MIXTURE. The pavement mixture for the wearing surface shall be composed of:

(a) Asphaltic cement (refined asphalt, heavy petroleum oil, or liquid asphalt).

(b) Clean, sharp sand.

(c) Finely powdered inorganic dust.

60. DEFINITION. The term asphalt shall be construed to signify any natural mineral bitumen, liquid or solid, which is adhesive, viscous, ductile, and elastic, or which becomes adhesive, viscous, ductile, and elastic on the application of heat. Said natural bitumen may be either in a state of purity or in admixture with native, non-bituminous matter.

61. COMPOSITION. The refined asphalt shall be obtained by refining crude natural asphalt until the product is homogeneous and free from water. Asphalt obtained from the distillation of asphaltic oils will not be accepted. It must not be affected by the action of water; must contain not less than ninety (90) per cent of bitumen soluble in carbon bisulphide, and of the bitumen thus soluble in carbon bisulphide not less than sixty-eight (68) per cent shall be soluble in boiling Pennsylvania petroleum naphtha (boiling-point from 40 to 60 centigrade); or, if it does not contain sixty-eight (68) per cent thus soluble in naphtha, but is satisfactory in other respects, the deficiency may be sup-

plied by fluxing the refined asphalt, with such a percentage of a viscous liquid asphalt, satisfactory to the engineer, as will bring it up to the required standard. It must comply in all respects with the tests enumerated in *a*, *b*, *c*, *d*, and *e* of Paragraph 62.

62. **PETROLEUM OIL.** Heavy petroleum oil, if used in the manufacture of the asphaltic cement as hereinafter described, shall be a petroleum from which the lighter oils have been removed by distillation without cracking, until it has a specific gravity of 15° to 22° Beaume and the following properties:

REQUIREMENTS. (*a*) Flash test not less than 300° Fahrenheit (the flash test shall be taken in a New York State closed oil-tester).

(*b*) Fire test not less than 350° Fahrenheit.

(*c*) No appreciable amount of light oils or matter volatile under 250° Fahrenheit.

(*d*) Matter volatile at 350° Fahrenheit in 24 hours, less than 8 per cent. (The test for "matter volatile at 350° Fahrenheit" shall be made with approximately 50 gms. of oil, in an open, flat-bottom, cylindrical dish 2½ ins. in diameter and 1¾ ins. high. The thermometer shall be applied so as to register the temperature of the oil.)

(*e*) It shall be free from coke and any manner or form of adulteration.

63. **LIQUID ASPHALT.** Liquid asphalt, maltha, or any other softening agent fulfilling the above test and approved by the engineer, may be used in place of heavy petroleum oil.

64. **ASPHALTIC CEMENT.** When refined asphalt is not already of the proper consistency an asphaltic cement shall be prepared by fluxing refined asphalt with heavy petroleum oil or other approved softening agent, complying with the above specifications, at a temperature between 250° and 350° Fahrenheit and in such proportion as to produce an asphaltic cement of a consistency to be determined by the engineer. The asphaltic cement shall

fulfil the requirements of paragraphs *a*, *b*, *c*, *d*, and *e* of Section 62 above.

65. As soon as the fluxing agent is added the entire mass shall be agitated by an air blast or other suitable appliance, and the agitation continued until a homogeneous cement is produced. The asphaltic cement must never be heated to a temperature exceeding 350° Fahrenheit. If asphaltic cement containing over ten per cent of foreign material is kept in storage, it must be thoroughly agitated when used, as must also all dipping kettles while in use.

66. SAND. The sand to be used shall be hard-grained, moderately sharp and clean, not containing more than 1 per cent of clay or loam. On sifting the whole shall pass a 10 mesh screen, 20 per cent shall pass an 80 mesh screen, and at least 7 per cent shall pass a 100 mesh screen.

67. INORGANIC DUST.—The inorganic dust shall be finely powdered carbonate of lime, granite, quartz, or other inorganic dust approved by the engineer. Such inorganic dust must be of such a degree of fineness that the whole of it shall pass a 30 mesh screen, and at least 66 per cent a 200 mesh screen.

68. PAVEMENT MIXTURE. The materials complying with the above specifications shall be mixed in proportions by weight, depending upon their character. These proportions will be determined by the engineer, but the percentage of matter soluble in carbon bisulphide in any pavement mixture shall not be less than nine and one-half nor more than twelve per cent. If the proportions of the mixtures are varied in any manner from those specified, the mixture will be condemned, its use will not be permitted, and, if already placed on the street, it will be removed and replaced by proper materials at the expense of the contractor.

69. The sand and the asphaltic cement will be heated separately to approximately 325° Fahrenheit. The stone dust shall be mixed, while cold, with the hot sand. The asphaltic cement will then be mixed with the sand and stone dust, at the required

temperature and in the proper proportion in a suitable apparatus, so as to effect a thoroughly homogeneous mixture. Sand boxes and asphalt gauges shall be weighed in the presence of inspectors as often as may be desired, and samples of any of the materials used shall be supplied to the inspector of asphalt at any time, and the engineer or his representative shall have access to all branches of the work at any time.

70. LAYING THE PAVEMENT. The above-described materials shall be mixed in the determined proportions in a standard asphalt-mixer and carried to the street at a temperature ranging from 250° to 325° Fahrenheit and spread upon the binder to such a depth as will insure a thickness of two (2) inches after ultimate compression. This compression will be attained by first smoothing the surface with a hand roller, or a light steam roller, after which hydraulic cement shall be swept over it, when the rolling will be continued with a ten ton roller until no impression is made upon the surface. A space of twelve (12) inches next the curb shall be coated with asphaltic cement and the same ironed into the pavement with hot smoothing irons.

71. ROCK ASPHALT.—Should any of the rock asphalts be used, the material shall be a natural bituminous limestone or sandstone or a mixture of the two, and shall be prepared and laid in the following manner: The lumps of rock, after being mixed in the proper proportions, shall be finely crushed and pulverized, and the powder passed through a twenty (20) mesh sieve. In case of the use of any asphaltic limestone, or of a mixture of an asphaltic limestone and an asphaltic sandstone, nothing whatever shall be added to or taken from the powder obtained by grinding the natural bituminous rock. Should it be proposed to use an asphaltic sandstone only, which contains more than nine (9) per cent of natural bitumen, of such a consistency that the resulting pavement would prove too soft to sustain traffic, the material, if satisfactory in other respects, shall be made to conform with the requirements of Section 73, by the addition of inorganic

dust, in such manner and in such proportion as the engineer may direct. The powder shall contain from nine (9) to twelve (12) per cent of natural bitumen.

72. LAYING. This powder shall be heated in a suitable apparatus to 200° or 250° Fahrenheit and must be brought to the ground at a temperature of not less than 180° Fahrenheit in carts made for the purpose, and carefully spread as specified for refined asphalt pavement, to such a depth that after having received its ultimate compression it will have a thickness of two and one-half (2½) inches when laid on concrete. When the foundation is other than concrete it shall be laid on a one inch binder course as heretofore described, and the net thickness of the rock asphalt wearing surface after compression shall be two (2) inches. The surface shall be rendered perfectly even by tamping, smoothing, and rolling with heated appliances of approved design.

73. GENERAL REQUIREMENTS. The materials complying with the above specifications shall be mixed in such proportions and within such limits, by weight, depending on their character, as shall be determined by the engineer, but whatever may be the character of the asphalt or of the asphaltic cement used, the pavement obtained must and shall conform to the following general requirements: The pavement when laid shall not be so soft as to be unfit for travel on the hottest days of summer, nor so hard as to disintegrate from the effect of frost. It shall contain no water nor appreciable amount of light oils, nor matter volatile at a temperature of 250° Fahrenheit. When laid the wearing surface mixture shall yield not less than nine and one-half (9½) nor more than twelve (12) per cent (except in the case of rock asphalt, when the limit shall be as established in Section 71) of bitumen soluble in carbon bisulphide, of which bitumen not less than sixty-eight (68) per cent shall be soluble in boiling Pennsylvania petroleum naphtha, boiling-point of 40° to 60° centigrade. All of the mineral matter shall pass a 10 mesh per linear

inch sieve, and not less than 18 per cent shall pass a 100 mesh per linear inch sieve, while the remainder shall be graduated between these limits. If rock asphalt be used the same shall be laid in accordance with Section 72.

74. In case of repairs it shall be required that such repairs be made with a pavement mixture equal to the above described.

75. **NO ASPHALT TO BE LAID IN WET WEATHER.** No asphalt shall be laid during wet weather, or unless the surface of the foundation is perfectly dry. All materials, as well as the plant and methods of manufacture, shall be subject at all times to the inspection and approval of the chief engineer of the Bureau of Highways or of such engineer or inspectors as may be in charge of the work.

76. **APPROACHES.** The curbstones, crosswalks, and gutters of the adjoining pavements and all pavements abutting the new work shall be readjusted and brought to the new grades and lines to the extent deemed necessary by the engineer, and such readjustment of curb and pavement shall include rejointing, resetting, and relaying as hereinbefore provided, at the prices stipulated.

77. **CLEARING UP.** All surplus materials, earth, sand, rubbish, and stones, except such stones as are retained by order of the engineer, are to be removed from the line of the work, block by block, as rapidly as the work progresses. All material covering the pavement and sidewalks shall be swept into heaps and immediately removed from the line of the work.

78. During the prosecuting of the work the contractor shall keep the footway clean by sweeping. When material is removed the sidewalk must be immediately swept clean by the contractor, and when public or local inconvenience is caused by dust the contractor shall water any piles or surface of earth or the sidewalks, or pavement foundation during sweeping when and where necessary or whenever required by the engineer to do so. The contractor must remove all stains or deposits of bitumen from sidewalks and adjoining pavements.

THE CITY OF NEW YORK, OFFICE OF THE PRESIDENT OF THE
BOROUGH OF MANHATTAN, BUREAU OF HIGHWAYS.

*Specifications for Regulating, Grading, and Paving or Repaving with
Asphalt-Block Pavement on a Foundation the Roadway
of from to together with all Work In-
cidental thereto.*

1. EXTENT OF WORK. This shall consist of (1) taking up the necessary curb, bridgestone, and such portions of the pavement that may be required to be removed for the proper laying of the pavement; (2) excavating the necessary portions of the roadway of subsoil, rock, or masonry where the same is above the proper subgrade or where the material underlying is not of proper character; (3) filling in depressions or openings in the roadway wherever said depressions are below the grade aforesaid or have been caused by the removal of improper material; (4) laying concrete as a foundation, as has been designated; (5) resetting catch-basins and resetting or furnishing and setting city manhole heads to grade; (6) furnishing and setting and redressing and resetting the necessary curbstones and heading stones, as required; (7) furnishing all the materials for, and laying an asphalt-block pavement in the roadway; (8) readjusting and relaying pavement and resetting curbstones in the approaches of intersecting streets and avenues; all to be in accordance with the plan and profile of the said street, now on file in the Bureau of Highways, with workmanship and materials equalling in every respect the requirements of these specifications and the samples accepted.

2. Material furnished and work done not in accordance with these specifications, in the opinion of the engineer, shall be immediately removed and so replaced or corrected as to be in accordance therewith.

3. ESTIMATE OF QUANTITIES. The estimates of the engineer of the quantity and quality of the supplies required, and the

nature and the extent, as near as possible, of the work, are herein stated and set forth.

-square yards of asphalt-block pavement.
-cubic yards of concrete, including mortar bed.
-linear feet of new curbstone, furnished and set.
-linear feet of old curbstone redressed, rejointed, and reset.
-noiseless covers, complete, for water manholes, to be furnished and set.
-noiseless covers, complete, for sewer manholes, to be furnished and set.

4. **PERSONAL EXAMINATION OF WORK.** Bidders must satisfy themselves by personal examination of the location of the proposed work, and by such other means as they may prefer, as to the accuracy of the foregoing statement, and they shall not, at any time after the submission of their bid, dispute or complain of such statement or estimate of the engineer, nor assert that there was any misunderstanding in regard to the nature or amount of the work to be done.

5. **WORK TO COMMENCE ONLY WHEN ORDERED ON.** No work will be paid for which is done before the contractor is ordered to proceed.

6. **PROSECUTION OF WORK.** The work under this contract shall be prosecuted at and from as many different points, at such times and in sections of such length along the line of the work, and with such force as the president may, from time to time, during the progress of the work, determine, at each of which points inspectors may be placed to supervise the same.

7. **MATERIAL NOT TO OBSTRUCT TRAVEL.** During suspensions all materials delivered upon, but not placed in the work, shall be neatly piled so as not to obstruct public travel, or shall be removed from the line of the work at the direction of the engineer, and unless the materials be so removed by the contractor upon notice from the engineer, the materials may

be removed by the president and the expense thereof charged to the contractor.

8. ENCUMBRANCES. The contractor shall remove at his own expense, when directed by the engineer, any encumbrances or obstructions on the line of the work, located or placed there prior to or after its commencement.

9. CONTRACTOR NOT TO DISTURB CITY MONUMENTS. The contractor shall not excavate around such city monuments and bench-marks as may come within the limits of or be disturbed by the work herein contemplated nearer than five (5) feet or in any manner disturb the same, but shall cease work at such locations until the said monuments or marks have been referenced and reset or otherwise disposed of by the president. The necessary labor to remove, care for, and reset all such monuments and bench-marks shall be furnished without charge therefor by the contractor.

10. MANHOLES, ETC., TO BE RESET. Such catch-basins, man-hole frames and heads for sewers, water pipes or other conduits belonging to the City on the line of the work as may be designated shall be reset to the new grades and lines by the contractor without extra charge therefor; and they shall be brought to such grades with brick masonry of the same thickness as that originally used, laid in hydraulic cement mortar, and the cost thereof shall be included in the price bid for the contiguous pavement. Noiseless covers, complete, with interchangeable ventilating and non-ventilating fittings, for water and sewer manholes, of the design approved by the engineer, shall be furnished and set when required, in the manner above designated, the cost of same to be included in the price bid per square yard for completed asphalt-block pavement. All other manholes and boxes are to be reset to the proper grade, under the contractor's direction, by the companies owning the same.

11. The grades of all manholes and boxes must conform absolutely to that of the pavement surrounding, and the contractor

shall supervise and see that all such resetting is substantially and accurately done in conformity with the foregoing, whether such resetting shall be done by his own men or by those from other companies, and he shall report in writing to the engineer any disinclination or negligence on the part of the latter to perform their work properly.

12. The contractor will be held strictly accountable for any variation or difference between the grades of reset manholes and boxes and that of the contiguous pavement, and any such difference existing on the completion of the work, or occurring during the maintenance period thereof, shall be corrected by the contractor at his own expense.

13. MATERIALS TO BE REMOVED.—BLOCKS AND BRIDGESTONES TO BE LOADED.—OLD CURBSTONES. All old materials necessary to be removed in the preparation for paving, excepting manhole heads and boxes and the materials herein mentioned, shall be the property of the contractor, and shall be immediately removed by him off the line of the work. Paving blocks that are to be used again shall be neatly piled, as hereinafter set forth, and such as are not so required, and all removed bridgestones, shall be loaded by the contractor into the carts or wagons of the Bureau of Highways and shall remain the property of the City. Old curbstones which cannot be utilized in accordance with the terms of these specifications shall become the property of the contractor, to be disposed of by him.

14. MATERIAL TO BE USED AGAIN.—PRICE FOR PAVEMENT TO INCLUDE REMOVAL.—Such other material which is specially suitable for use in the work shall be collected, piled, and utilized as directed by the engineer. All the work of removing and loading old material, as above, shall be included in the price bid per square yard of pavement.

15. EXCAVATION AND FOUNDATION.—The pavement and other materials necessary to be removed shall be taken up and disposed of, as required, and the roadways excavated of all sub-

soil or other matter, be it earth, rock, or other material, to a uniform subgrade seven and one-half ($7\frac{1}{2}$) inches below the top of the finished pavement, or to such other depth as the engineer may require. No ploughing will be allowed within six (6) inches of such subgrade, except by permission of the engineer.

16. SPONGY MATERIAL.—All spongy or objectionable matter disclosed by the excavations thus made shall be removed, and the space filled with acceptable material, compacted by thorough ramming.

17. ROLLING.—UNSATISFACTORY MATERIAL TO BE REMOVED.—When required, the entire roadbed, after having been brought to the necessary subgrade, shall be rolled with a steam roller until the surface is thoroughly compacted and the inaccessible portions shall be tamped, wetted, and tamped or rolled with a small roller and wetted, as may be directed. Material not admitting of satisfactory rolling shall be removed, and such new material as may be necessary to replace the same or bring the pavement to the proper grade shall be supplied and placed by the contractor without extra compensation therefor. It shall be good, wholesome earth, free from foreign matter, and shall be placed in layers not more than six (6) inches in depth and rolled or rammed as above or as may be directed.

18. ROADBED SHAPING.—Great care shall be exercised in shaping the roadbed to secure a uniform surface parallel to, and the required depth below, the given grade and crown, and the entire cost of such excavation and shaping shall be included in the price paid for pavement.

19. SAND BED.—On the roadbed thus prepared shall be laid a concrete foundation of the materials and thickness set forth in these specifications, and thereon shall be spread a layer of cement mortar to such a depth (in no case less than one-half [$\frac{1}{2}$] an inch) as may be necessary to bring the surface of the pavement to the proper grade.

20. DELIVERY OF MATERIAL AND INSPECTION.—The materials

for construction shall not be brought to or deposited on the street in quantities greater than is necessary for convenient working, and shall be so deposited as to cause the least possible obstruction to streets and sidewalks, as may be determined by the engineer. All new material of every description shall be carefully inspected after it is brought on the streets, and all such not conforming in quality and dimensions to these specifications will be rejected and must be immediately removed from off the line of the work.

21. ASSISTANCE TO BE FURNISHED. The contractor shall furnish such laborers as may be necessary to aid the engineer in such examinations, and in case he shall neglect or refuse so to do, such laborers as may be necessary will be employed by the president and the expense therefor will be deducted from and paid out of any money then due or which may thereafter become due to the said contractor under this agreement.

22. PILING OF MATERIAL.—All old and such new material as has been approved, except sand and broken stone, shall be neatly piled by the contractor on the front half of the sidewalk, on planks not less than one (1) inch thick if the same be flagged or otherwise improved, not within ten (10) feet of any fire hydrant and with sufficient passageways to permit of free access from the roadway to each and every house on the line of the work.

23. Not until this has been done and the rejected materials removed entirely from the line of the work, each of which conditions must be faithfully fulfilled, will the contractor be permitted to proceed with the laying of the pavement.

24. OLD CURBSTONES THAT MAY BE RESET.—Old curbstones which can be redressed to a top width of not less than four and one-half ($4\frac{1}{2}$) inches, are not less than sixteen (16) inches deep, and are of the quality hereafter specified, shall be redressed, re-jointed, and reset as directed below. All friable granite curbstones shall be rejected.

25. QUALITY, DIMENSIONS, AND DRESSING OF NEW CURBSTONE.

—New curbstones shall be hard, sound, fine-grained, and uniform colored bluestone, shall be free from seams and other imperfections, and shall be equal in quality to the best North-River bluestone. They shall be inches in depth, from three and one-half ($3\frac{1}{2}$) to eight (8) feet in length, and not less than five (5) inches in thickness (except as noted for bottom of curb), with square ends of the full average width. The face for a depth of inches and the top, on a bevel of one-half ($\frac{1}{2}$) an inch in its width of five (5) inches, shall be dressed to a surface, which shall be out of wind and shall have no depressions measuring more than one-quarter ($\frac{1}{4}$) of an inch from a line or straight edge of the same length as the curbstone. The remainder of the face shall be free from projections of more than one-half ($\frac{1}{2}$) an inch, and the back for three (3) inches down from the top shall have no projections greater than one-quarter ($\frac{1}{4}$) of an inch measured from a plane at right angles to the top. The bottom of the curb shall be rough-squared with a width of not less than three (3) inches.

The sample of the curbstones showing the dressing and the jointing required can be seen at the office of the chief engineer of the Bureau of Highways.

26. JOINTING.—For the full width of the stone for a distance down the same as the above-mentioned depth of dressed face from the top, and there below to the bottom for a width of two (2) inches back from the face, the ends shall be squarely and evenly jointed. In no case shall the ends of the curbstones abutting basin-heads be bevelled off or reduced in width, but recesses shall be neatly cut in such basin-heads without charge therefor, to give square, close joints or the full width of the stones.

27. SETTING.—Each curbstone shall be set truly to grade and line and on a face batter of one (1) inch in its depth, or vertically as shall be directed; it shall be firmly bedded and tamped, and the rear to the top back filled and tamped, with clean, dry, gritty earth or coarse sand, free from rock fragments, or as hereinafter more particularly set forth, and the vertical face joints of all

curbstones shall be flush pointed firmly with good mortar of one part of Portland cement and two of sand from the top of the curb to the top of the foundation of the asphalt-block pavement.

28. CORNER CURBSTONES.—Curved curb for corners shall be cut with true radial joints and set accurately to a radius of six (6) feet in three (3) foot lengths, unless otherwise required. It shall be paid for as straight curb, and must comply in all respects with the above requirements therefor.

29. The cost of excavation necessary for curb-setting shall be included in the price paid per linear foot of curb, and no compensation therebeyond shall be made or allowed.

30. CURB ON CONCRETE.—When specified, the curbstone aforesaid shall be set on a concrete foundation and the price submitted per linear foot for new curbstone shall include the furnishing of the stone and all the excavations necessary for the concrete foundation.

31. CONCRETE BED FOR CURBSTONE.—The concrete foundation for curbstone shall not be less than six (6) inches thick and eighteen (18) inches in width and be of the materials and proportions hereinafter described except that the broken stone shall not be less than one-quarter ($\frac{1}{4}$) nor more than one and one-half ($1\frac{1}{2}$) inch maximum dimensions; the curb to be immediately bedded on the centre thereof, with a bearing for its full length as soon as the concrete is laid, and it shall be at once backed up with concrete for a width of six (6) inches, extending from the bottom bed to within four (4) inches of the top of the stone. The concrete so used will be paid for at the general price bid per cubic yard for concrete.

32. FRONT CONCRETE.—Simultaneously with the backing up in the rear, the concrete in front of the curb shall be carried up, for the exposed width of the bottom bed, to the elevation of the bottom of the paving foundation, and so much of said paving foundation itself as may be necessary, for a width not less than six (6) inches from the curb, shall be immediately laid to serve as

a support for the curbstones. When set the corners of the curb at the top shall be a straight and true line, and the upper and face surfaces a plane surface.

33. IN FRONT OF CONCRETE WALKS.—When curb is set in front of a monolithic, cement, or concrete sidewalk, the space between the curb and sidewalk foundation shall be completely filled with concrete, similar to that on which curb is set, to within two (2) inches of the top; the remaining space to be filled with Portland cement of the quality hereinafter specified, mixed with equal parts of crushed stone used for the wearing surface of such walks. The concrete used for foundation and setting curbstones will be paid for by the cubic yard, the same as the price bid for concrete, and the dimensions will be based upon these hereinbefore stated.

34. REMOVAL OF FLAGSTONES.—MONOLITHIC WALKS.—BACK-FILLING.—The front course of flagstones when not over four (4) feet in width interfering with the work of curb-setting shall be picked up and be set back, and after the curb has been set and thoroughly backfilled they shall be fitted in their original position and the cut edge be retrimmed and rejointed to a true line to give a joint when possible, not more than one-half ($\frac{1}{2}$) an inch wide at the back of the curb and be so relaid to the new curb grade when such grade does not differ more than (5) inches from that originally existing; the stone to be thoroughly bedded and the joints cemented as herein set forth. Stone of unusual size and those containing coal-hole openings, ventilation, or light castings shall in no case be disturbed, but the front edge shall be rejointed to line, as above in place. Monolithic walks shall be carefully cut off to a true line, five and one-half ($5\frac{1}{2}$) inches back of and parallel to the new curb-line, and for use in such locations curbstones shall be selected of as near as possible a uniform width throughout its depth that the foundation of the walk may not be unnecessarily damaged. The entire space between back of curb and such walks, or stones that are left in place (except where

curbstones are to be set in concrete as above described), shall be backfilled with fine sand, free from gravel and stones, to within two (2) inches of the top of the curbstones, water being freely used to settle and compact the same. The remaining space shall be filled with Portland cement mixed with sand or stone as used for such walks, to be neatly trowelled to place, and the contact surfaces of stones and walks shall be made clean and wet while filling and trowelling the said two (2) inches.

35. Any damage done by the contractor to sidewalks in curb-setting, handling, or in the storage of materials shall be made good by him, at his own expense, as shall be directed by the engineer.

36. NEW FLAGGING, QUALITY AND DIMENSIONS.—DRESSING OF FLAGSTONE.—New flagging furnished to replace any broken shall be of bluestone of even color and best quality, and satisfactory to the president, not less than three (3) inches thick, even on its face, free from seams, flaws, drill-holes, or discoloration, measuring not less than four (4) feet wide, and containing not less than twelve (12) superficial feet or of the same size as that broken, as shall be directed; the stones to be chisel-dressed, with sides parallel, on the four edges a distance down of one (1) inch from the top and at right angles thereto; except that, in sidewalks where stones of superior dimensions or quality are broken, the replaced stone must be in length and width not less than the old stone and be of the same quality of material.

37. LAYING OF FLAGSTONE.—CLEARING UP.—All flagging to be relaid shall be firmly and evenly bedded to the grade and pitch required, on four (4) inches of steam ashes, clean, gritty earth or sand, free from clay or loam, and the work brought to an even surface, with all joints close and thoroughly filled (except around monuments and trees), for the full depth with cement mortar, composed of equal parts of the best Portland cement and clean sharp sand, and left clean on the surface, and all earth, débris, and surplus material shall be removed from each block and the side-

walks swept clean as soon as the work thereon has been completed.

38. **HEADING STONES.**—Wherever the new pavement abuts pavement of a different character, and wherever directed to do so, the contractor shall put down bluestone heading stones at least three (3) feet long and one (1) foot deep and set with full bearing on a bed of concrete nine (9) inches wide and six (6) inches deep, of the quality hereinafter described. These heading stones shall be of good, sound bluestone, free from lamination or seams. They shall be dressed square on top to a good surface, free from irregularities, and to a uniform width of not less than four and one-half ($4\frac{1}{2}$) inches. The ends shall be joined square down to give close joints, and the bottoms shall be nowhere less than three (3) inches wide and be cut to give a full, square bearing throughout, and the sides shall be free from bunches. These stones shall be maintained by the contractor, and they will be paid for as asphalt-block surface.

39. **SIZE OF BLOCKS.—PROPORTIONS OF MATERIALS.**—The sizes of the blocks used must be five (5) inches wide, three (3) inches deep, and twelve (12) inches long, and a variation of one-quarter ($\frac{1}{4}$) of an inch from these dimensions will be sufficient ground for rejecting any block. The blocks must be composed of crushed trap rock, pulverized carbonate of lime, and asphaltic cement, mixed in the following proportions, by weight, and no change from such proportions shall be made without the permission of the engineer:

Asphaltic cement	6 to 11 parts
Crushed trap rock	89 to 74 parts
Pulverized carbonate of lime	5 to 15 parts

40. **ASPHALTIC CEMENT.**—The asphaltic cement shall be composed of refined asphalt and a liquid asphalt or other suitable flux. The refined asphalt and flux shall be mixed in such proportion as will produce an asphaltic cement of a consistency and quality as approved by the engineer.

The refined asphalt shall be obtained by refining crude natural asphalt until the product is homogeneous and free from water. Asphalt obtained from the distillation of asphaltic oils will not be accepted. It must not be affected by the action of the water; must contain not less than ninety (90) per cent of bitumen soluble in carbon bisulphide, and of the bitumen thus soluble in carbon bisulphide not less than sixty-eight (68) per cent shall be soluble in boiling Pennsylvania petroleum naphtha (boiling-point from 40 to 60 centigrade); or, if it does not contain sixty-eight (68) per cent thus soluble in naphtha, but is satisfactory in other respects, the deficiency may be supplied by fluxing the refined asphalt with such a percentage of a viscous liquid asphalt, satisfactory to the engineer, as will bring it up to the required standard. The refined asphalt, the asphaltic cement, and the flux must each comply in all respects with the following tests:

(a) Flash test not less than 300° Fahrenheit. (The flash test shall be taken in a New York State closed oil-tester.)

(b) Fire test not less than 350° Fahrenheit.

(c) No appreciable amount of light oils or matter volatile under 250° Fahrenheit.

(d) Matter volatile at 350° Fahrenheit in 24 hours, less than 8 per cent. (The test for "matter volatile at 350° Fahrenheit" shall be made with approximately 50 gms. of oil, in an open, flat-bottom, cylindrical dish 2½ ins. in diameter and 1¾ ins. high. The thermometer shall be applied so as to register the temperature of the oil.)

(e) It shall be free from coke and any manner or form of adulteration.

41. TESTING OF BLOCKS.—The blocks furnished will be subject to the approval of the engineer, and shall withstand such tests for specific gravity, abrasion, tensile and crushing strength as he may prescribe. Whatever the character of the asphalt used, the block shall yield, when extracted with bisulphide of carbon and after the evaporation of the solvent, not less than five and one-

half ($5\frac{1}{2}$) nor more than seven and one-half ($7\frac{1}{2}$) per cent of bituminous matter, except when other percentages are specially permitted by the engineer.

The trap rock used in making the blocks must be entirely free from dirt and other impurities, and must be crushed so that every particle will pass a screen having holes one-quarter ($\frac{1}{4}$) inch in diameter. The blocks must receive a compression in the moulds of not less than one hundred and twenty (120) tons upon each block; and must weigh not less than fifteen and one-half ($15\frac{1}{2}$) pounds per block.

42. The engineer shall further have the right to make tests and examinations at the contractor's works of the materials proposed to be used, and to reject any or all such materials as he may consider not to be in compliance with these specifications.

43. INSPECTION.—The blocks will be carefully inspected after they are brought on the line of work, and all blocks which in quality and dimensions do not conform strictly to the requirements will be rejected and must be immediately removed from the line of work.

44. CEMENT.—The cement shall be of the best quality of American Portland, samples of which must be submitted at least ten (10) days (holidays and Sundays excluded) before using, for the inspection and approval of the chief engineer, and no change from such approved brand shall thereafter be made without the submission and approval of samples. It will be required that the various deliveries shown by samples taken from the work during its continuance shall exhibit qualities equal or superior to those developed by the samples submitted as aforesaid.

45. QUALITY.—TENSILE STRENGTH.—All cements shall be freshly ground and of a uniform quality, color, and weight, and briquettes of one (1) square inch section shall develop or exceed the following tensile strength:

Neat, one hour air, twenty-three (23) hours in water, 200 lbs.;

neat, one day air, six (6) days in water, 400 lbs.; neat, one day air, twenty-seven (27) days in water, 480 lbs.; one of Portland, three (3) of sand, one day air, six (6) days water, 150 lbs.

46. CONCRETE, PROPORTIONS OF MATERIALS.—THE UNIT OF MEASURE.—The concrete shall be composed of one (1) part of cement, three (3) parts of sand, and six (6) parts of broken stone, but should the proportion of voids in the stone be such that a greater or less quantity of stone be required to give satisfactory results, the amount of broken stone shall be increased or decreased to the extent directed by the engineer upon any particular piece of work. The unit of measure shall be the barrel of cement as packed by and received from the manufacturer.

47. SAND AND BROKEN STONE.—TO BE STORED ON PLATFORM.—The sand shall be clean, coarse, and sharp, and be free from loam or dirt. The broken stone shall be of trap, granite, or limestone, or such other stone taken from line of the work as shall be satisfactory in the judgment of the engineer. It shall be entirely free from dust and dirt and be of graded sizes that will pass in any direction through a revolving circular screen having holes two and one-half ($2\frac{1}{2}$) inches in diameter, and be retained by a screen having holes one (1) inch in diameter. The sand and stone must be placed upon board platforms and kept free from dirt, and the cement shall be properly blocked up and protected from dampness.

48. SIZE OF BATCH.—MIXING.—USE OF MIXING MACHINE.—Concrete, unless machinery be used, shall be mixed in batches, containing not more than one (1) barrel of cement with the requisite proportion of other material, on suitable tight platforms, not less than twelve (12) feet by twelve (12) feet in size. The cement and sand shall be thoroughly mixed dry after which the broken stone, having first been wetted, shall be added. The whole mass shall then be turned and worked by skilled laborers, until a resultant is obtained, with the stone uniformly distributed. In shovelling, the material must be lifted clear of the board. If

a concrete mixing machine be used, the cement and sand shall be mixed as above and precautions taken to insure the proper proportion of each of the materials, so that the resultant mixture shall be uniform in quality.

49. LAYING.—CONCRETE SURFACE TO BE SCABBLED.—The concrete shall be placed in position and there rammed with proper rammers until thoroughly compacted. The whole operation of mixing and laying each batch must be performed as expeditiously as possible, and in no case shall concrete be used which has been mixed more than one-quarter ($\frac{1}{4}$) of an hour. The concrete shall be protected from the weather until set, and should it at any time be considered by the engineer to be poorly mixed or not to be setting properly, such portions shall be taken up and replaced with satisfactory material. Sufficient time, of which the engineer shall be the judge, shall be allowed for the concrete to set before the pavement is laid thereon. Before laying concrete to connect with, rest upon, or overlap any concrete previously laid, the entire surface of contact of the latter shall be swept and washed clean of all dirt and mortar particles and, when deemed necessary, shall be satisfactorily scabbled.

50. NO TRAFFIC ON CONCRETE.—No horses, carting, or wheeling shall be allowed on the concrete until the same has thoroughly set, and then only on planks furnished and laid by the contractor. By car tracks the contractor shall provide men to pass cars thereover.

51. THICKNESS AND TESTING.—The concrete foundation shall be four and one-half ($4\frac{1}{2}$) inches thick, including a mortar top surface of one-half ($\frac{1}{2}$) inch in thickness, the concrete proper being four (4) inches thick and shall withstand such tests as the engineer may deem necessary, and the contractor shall furnish such samples as may be required for the purpose.

52. On the concrete surface, after the same has been swept and made wet, shall be spread a layer of cement mortar to such thickness that when struck to a surface three (3) inches below and

exactly parallel to the grade of the completed pavement its depth shall be nowhere less than one-half ($\frac{1}{2}$) an inch. The mortar shall consist of one (1) part of slow-setting Portland cement, of an approved quality, mixed with four (4) parts of clean, sharp sand, free from gravel, over one-quarter ($\frac{1}{4}$) of an inch in diameter, and it shall be spread and surfaced as follows:

53. On the surface of the concrete shall be set strips of wood four (4) inches wide by one-quarter ($\frac{1}{4}$) inch thick, or strips of steel four (4) inches wide by not less than one-eighth ($\frac{1}{8}$) inch thick, and of the greatest length convenient for handling. These strips shall be carefully set parallel and about eight (8) or ten (10) feet apart, running from curb to curb, and be embedded in mortar throughout their length so that the top surface shall be three inches below and parallel to the grade of the finished pavement. The space between two strips having been filled with mortar, a true and even top surface shall be struck by using an ironshod straight edge on the strips as a guide, and as soon as the bed has been struck the strip which would interfere with laying the block shall be removed and its place carefully filled with mortar with a trowel.

54. If the width of the roadway be such that the laying of blocks on a complete section cannot be completed before the mortar takes its initial set, the strips may be placed parallel to the curb, and templates cut to the curve of the desired crown shall be used on these strips to strike the bed.

55. SAND BED.—On this mortar surface, spread and smoothed as above to the proper crown and grade, the blocks are to be laid with close joints and uniform top surface, in courses at right angles to the line of the street, except in and between car tracks, in intersections, and in other special cases, when they shall be laid diagonally, as shall be directed.

56. CUTTING CLOSURES.—Nothing but whole blocks shall be used except in starting a course or in such other cases as shall be specially permitted by the engineer, and in no case shall less than

one-third of a block be used in breaking joints. Closures shall be carefully cut and trimmed by experienced men, the portion of the block to be used to be free from check or fracture and the cut end to have a surface normal to the top of the block and be cut at the proper angle to give a close, tight joint.

57. LAYING.—Each course of blocks shall be of uniform width and depth, with all joints close and the end joints broken by a lap of at least four (4) inches, and, while laying, the pavers must stand on those already laid. Any lack of uniformity in the surface or unevenness in the blocks must be immediately corrected by taking up and relaying the blocks, and blocks fractured or broken shall be replaced with perfect ones before any sand is spread over the surface.

58. SAND JOINTS AND COVERING.—When laid, the blocks shall be covered with clean, fine sand, entirely free from loam or earthy matter, perfectly dry and screened through a sieve having not less than twenty (20) meshes per linear inch, the sand to be swept and brushed into the joints and left on the surface until such time when, if required by the engineer, the pavement shall be swept clean for final inspection and any defects then noted shall be remedied.

59. READJUSTING OF ADJOINING PAVEMENT.—The curbstones and gutters of the adjoining pavements, and all pavements abutting the new work, shall be readjusted and brought to the new grades and lines to the extent deemed necessary by the engineer, and such readjustment of curb and pavement shall include rejointing, resetting, and relaying as herein provided, all without charge therefor.

60. In readjusting such abutting pavements, all imperfect stones shall be discarded and only those of regular shape used, and before the old pavement of the street being paved shall have been removed the contractor shall select therefrom enough perfect stones, and preserve the same till needed, to make up any deficiencies. On the contractor's failure so to do, he shall pro-

vide such extra necessary stones at his own expense and to the satisfaction of the engineer.

61. The stones shall be laid in straight and regular courses, with close end joints broken by a lap of at least three inches. The joints between courses shall be close except when gravel filling is to be used, and the courses shall be carried parallel to the existing courses; any differences in alignment between such courses and the header shall be corrected at the header by neatly trimming the blocks. None but stones of the same width shall be used in the same course except where trimming is necessary.

62. All stones shall be relaid on a full bed of sand and be thoroughly rammed to a firm unyielding bearing and to a uniform surface, the joints to be brushed full of sand.

63. When the pavement is to be relaid on a concrete foundation with joint filling, such foundation, if required by the engineer, shall be removed and relaid, or be added to with concrete as may be necessary; all other detail to be in accordance with the current specifications for similar work in use in the Bureau of Highways.

64. REMOVAL OF SURPLUS MATERIALS, RUBBISH, ETC.—All surplus materials, earth, sand, rubbish, and stones are to be removed from the line of the work, block by block, as rapidly as the work progresses; all material covering the pavement and sidewalks shall be swept into heaps and immediately removed from the line of the work; and unless this be done by the contractor within forty-eight hours after being notified so to do, by a written notice to be served upon the contractor, either personally or by leaving it at his residence or with any of his agents on the work, to the satisfaction of the president, the same shall be removed by the said president and the amount of the expense thereof shall be deducted out of any moneys due or to grow due to the contractor under this agreement.

65. SWEEPING AND SPRINKLING.—At all times during the prosecution of the work, such materials as may be placed on the

sidewalk shall be piled in the manner heretofore set forth, and the contractor shall keep the footway clean by sweeping. When such material is removed, the sidewalk must be immediately swept clean by the contractor, and when public or local inconvenience is caused by dust, the contractor shall water any piles or surfaces of earth or the sidewalks or pavement foundation during sweeping, when and where necessary or whenever required by the engineer so to do.

66. PATENTED ARTICLES.—That whenever or wherever an article or any class of materials is specified by the name of any particular patentee, manufacturer, or dealer, or by reference to the catalogue of any such manufacturer or dealer, it shall be taken as intending to mean and specify the article or materials described, or any other equal thereto in quality, finish, and durability, and equally as serviceable for the purposes for which it is (they are) intended. Nothing in these specifications shall be interpreted or taken to violate the provisions of section 1554 of the Greater New York Charter, which provides that “except for repairs no patented pavement shall be laid and no patented article shall be advertised for, contracted for, or purchased, except under such circumstances that there can be a fair and reasonable opportunity for competition, the conditions to secure which shall be prescribed by the Board of Estimate and Apportionment.”

CHAPTER X

MODERN WOODEN PAVEMENTS

DEFINITION. Such a term implies one in which the surfacing material consists of wooden blocks, of approved form, which may or may not have been impregnated with some preservative to prevent decay and expansion, laid upon a suitable foundation.

HISTORY. Wooden pavements are by no means a new departure either in this country or abroad, for in Europe they have been known for several hundred years, having been first laid in Russia in the form of hexagonal blocks, while in the United States they have been employed during the past seventy years, first being laid in New York City about 1835.

In Europe they have given unquestionable satisfaction, so that both London and Paris are quite predisposed in their favor. The former city began the use of wooden-block pavements about 1839, but with little success as the soft wood, inferior quality of the same, poor foundation, and general lack of knowledge regarding construction produced a covering that was quickly disrupted.

In the light of experience, however, and with the use of hard woods carefully cut and laid on a concrete base, better results have been obtained. That such pavements may be satisfactorily employed under the severest conditions of traffic is instanced in that on the very busiest thoroughfares of both London and Paris, such as the Strand and the Avenue de l'Opéra, wooden blocks are selected in preference to all others.

The reason for the marked success of wooden block abroad, as compared with the lack of it in this country, is that there very

much more attention is given to the selection and treatment of the material used, to the foundation, to the joints, and to the maintenance of the pavement after it is laid. Heretofore, in the United States, green wood has been frequently used, laid upon an improper or poorly constructed foundation, with a joint filling, failing in its purpose to keep out the moisture, and with too little or no regard for maintenance. Besides this, the many and great advantages of brick pavements have tended to reduce the demand for wooden blocks. The present practice, however, indicates that better results are being obtained; due, unquestionably, to a marked improvement of laying, and also to an increasing regard for the fundamental principles underlying maintenance.

ADVANTAGES. It would seem from a careful examination that the advantages in favor of wood pavements far outweigh the disadvantages. The former may be stated as follows:

1. Smooth.
2. Low in tractive resistance, requiring much less effort to haul a unit load than over a granite-block pavement, and only a little more than that required on asphalt.
3. Noiseless, so that wooden block has been popularly termed "the silent pavement." In this respect wood is superior to asphalt in that horses' hoofs do not resound upon it, and it may be said to have "the effect of a carpet of tan bark as compared with pavements of stone." For this reason it is particularly desirable in the vicinity of hospitals, schools, churches, and other places where noise may not be tolerated.
4. It affords an excellent foothold on grades less than about four per cent, and has been used on grades greatly in excess of this, where the traffic was heavy. It is true that under certain weather conditions the pavement becomes slippery, but hardly to a greater degree than asphalt.
5. It is clean, sanitary, easily cleaned, creates no mud, nor does it pulverize, as asphalt, into a fine dust.

6. It is suited to all kinds of traffic, from the lightest to the heaviest.

7. It is durable, lasting longer than any other pavement but granite block. For example, in Boston, such a pavement, laid on Tremont Street, where the traffic is heavy, shows after seven years of continuous service a compression or wear of the blocks to the extent of only three-sixteenths inch. Such wear is due to horses' hoofs as much as to the action of wagon wheels, and the former increases very materially with increase in grade. Wide joints also promote wear, as then the fibres of the blocks more easily spread or broom.

8. The pavement is easily maintained and presents no difficulties, when access is desired, either in the removal of the blocks or the replacement of the same.

DISADVANTAGES. The principal disadvantages seem to be:

1. Cost; this factor rising to \$3.00 per square yard, including the concrete foundation.

2. It is said to be hard to clean compared with asphalt.

3. In wet weather it is slippery.

These statements are only relative, for while it may be harder to clean a wooden-block pavement than asphalt, on the other hand it is very much less difficult than granite or stone block. It may be said also that though wooden block becomes slippery during rainy weather, this condition may be counteracted somewhat by the application of sand to the surface. Objections, too, have been raised on the ground that it is unsanitary as the wood is porous and the joints not always watertight. The porosity permits of absorption, while the joints allow the moisture to sink beneath the surface, there to deposit as a thick slimy liquid with a strong ammoniacal odor, which is both annoying and unhealthy. That such conditions need not exist is proven by the fact that in London after thirty years' experience complaints of this nature had never been received.

Within the past few years the popularity of wooden-block

pavements has greatly increased in the United States so that in 1906 Indianapolis, New York, Minneapolis, Toledo, and Boston alone had over 1,400,000 square yards of such pavements laid.

WOOD USED. At present the woods most commonly used in the United States are Long-leaf Yellow Pine, Southern Black Gum, Norway Pine, Tamarac, Washington Fir, and Cedar.

In England, however, both the hard and soft varieties are employed, the former including principally those from West Australia, Jarrah and Karri, and the latter, Baltic Redwood and Yellow Deal.

The choice between hard and soft woods depends chiefly upon the local conditions, as any wood which is sound, well seasoned, free from sap, shakes, and knots, close-grained, and uniform in quality, whether hard or soft, is satisfactory.

Hard woods, being closer grained, absorb less moisture and are therefore more sanitary, besides which they wear longer, and are usually laid without being treated with a wood preservative as the latter can enter to only a small degree. Very hard woods such as Oak are, however, slippery, do not give as good a foothold, and do not wear as evenly.

Soft woods are laid both with and without treatment, but under the latter circumstances they are never so satisfactory unless the extremely rapid wear precludes the advisability of using a preservative. Without impregnation, soft-wood blocks absorb moisture, are unsanitary, and quickly broom.

DOUGLAS FIR OR OREGON PINE is the most satisfactory wood that may be selected because it is so extremely uniform and homogeneous in character. In consequence of this one characteristic, it wears uniformly and, while not so hard and tough as Long-leaf Yellow Pine or Black Gum, gives a much superior pavement. It is not so well suited to streets where the very heaviest traffic is, but under generally normal conditions it is the best that may be employed. East of the Mississippi River, however, its cost is prohibitive.

LONG-LEAF YELLOW PINE is the wood most frequently used, but as it is becoming more and more scarce and expensive, substitutes are being sought for in its stead.

SOUTHERN BLACK GUM has been satisfactorily employed in Boston, but not long enough to definitely determine its qualities. The wood in itself is cheaper than Yellow Pine, and there is less waste to it in cutting, shipping, and handling, but it is heavier, costing more for transportation, takes longer to dry, and requires a larger quantity of preservative per cubic foot than Yellow Pine.

CEDAR has been extensively used in Chicago, where it is laid in the form of round blocks; but the present-day tendency is not toward either that shape or sort of wood.

NORWAY PINE and TAMARAC are also employed, but not to the same extent as the others.

The only question as to the superiority of one wood over another, provided a preservative has been applied, is that of durability. "The probability is that the treated woods are equally good as the untreated provided the traffic does not pass the limit of durability."

"It would seem that for each class of timber there is a condition of traffic beyond which it should not be subjected." For the heaviest the more durable woods are required, such as long-leaf yellow pine and black gum; where the traffic is not of the heaviest, woods as soft as Norway Pine may be used, and where it is light, almost any wood may be used that will not decay.

FORMS OF BLOCK. The forms of block used are numerous and various, differing materially both in shape and size. The shapes include round, square, rectangular, oblique, hexagonal, octagonal, and many other interlocking forms, but present tendencies favor one that is rectangular, as it is superior in many ways. In Europe rectangular blocks are used almost without exception.

The dimensions depend upon the same factors that govern the size of granite blocks, and are usually found to lie between the

following values: width, 3 to 4 ins.; depth, 4 to 6 ins.; length, 9 to 12 ins. The width is influenced by the size of a horse's hoof, the depth by the most economical value that may be used to secure a maximum amount of wear before renewal, leaving a minimum thickness to be discarded, and the length upon the fact that blocks too long split readily.

As blocks wear down 2 or 3 ins., they become rough and must be replaced by others, in consequence of which a thickness of 6 ins. is never exceeded and seldom reached, as it involves too great a waste of material.

Uniformity in the size and shape of the block is essential to insure parallel faces, narrow joints, and regularity in the breaking of joints; to secure this, the wood is carefully cut by machinery and inspected rigidly to eliminate faulty material.

CHEMICAL TREATMENT

While it is true that in the early practice untreated blocks were laid only, present specifications usually require that the wood shall have been impregnated with some preservative fluid. The purpose of this is that the pores may be filled by the liquid or solution, preventing the absorption of moisture and air and thus decay, and also to prevent change in size.

This is the principal difference between old and new forms of wooden pavement.

If the wood is prevented from decaying, then the life may be said to depend upon the durability of the material itself, all other things being equal.

Many methods have been employed for the preservation of wood, but those more generally used are: kyanizing, using a solution of corrosive sublimate; burnettizing, in which zinc chloride is employed; and creosoting, in which creosote usually with some other ingredient is impregnated. The two latter are the ones most generally used; and of these, creosoting is the best.

LAYING THE PAVEMENT

FOUNDATION. During the past, various foundations have been tried in the United States, and usually with not too satisfactory results. This may be partially explained by the fact that in early days, when lumber was more plentiful and cheaper, and the blocks were untreated, the pavement was not always carefully designed and laid, nor had practice developed the standards of excellence that exist to-day.

Wooden blocks have been laid directly upon the natural soil, on one or two layers of plank resting upon the ground or a layer of sand, and upon a concrete base. In all but the last the pavements wear out quickly, and far from demonstrate the possibilities that exist in wood.

It is claimed that, laid upon a well-prepared foundation of the natural soil, a wooden-block surfacing is cheap; but, on the other hand, its life is short as the blocks quickly decay and the pavement soon needs mending.

Where planks are used resting upon a coat of sand, it is customary to place 1 to 2 in. by 10 to 12 in. stringers longitudinally on the soil along the street, spaced 8 to 10 ft. centre to centre, and on top of these, transversely, with close joints, planks of approximately the same dimensions. The ends of the latter rest upon the stringers, and are supported between by the sand in which the stringers are embedded. Such an arrangement distributes the pressure and gives a pavement that has been found to be satisfactory in Chicago, where they are extensively used.

Concrete forms, undoubtedly, the best foundation of all. It is laid to a depth of 4 to 6 ins., depending upon the nature of the traffic and the subsoil. Over the concrete is placed a cushion coat of sand $\frac{1}{2}$ to 1 in. deep, or a thin layer of neat cement or grout for the purpose of taking up all irregularities and of insuring an even-bearing surface for the blocks.

The blocks themselves are always placed with the fibre verti-

cal to prevent splitting, and with the long edge perpendicular to the axis of the street.

JOINTS should be made as small as possible since wide ones cause the fibres to spread. This applies more particularly to streets with grades less than 3 per cent, as above that open joints, $\frac{1}{4}$ to $\frac{3}{8}$ in., are frequently laid to afford a foothold. When the blocks are placed close together, with small joints, the filling used is either fine hot sand, Portland-cement grout, or hot paving cement. Sometimes the joint filling consists of a bituminous cement for a depth of 2 ins., while on top of this is placed cement grout in the proportions of 1 of cement to 3 of sand. Where soft woods are used, the surface may be flushed with hot tar which is brushed into the joints, while with hard woods one end and one side may be dipped into a hot paving-pitch composition with the material adhering, forming the joints.

Where bitumen is used in close joints, it allows for the expansion of the blocks, permits the street being thrown open for traffic, and gives a more even surface, because it prevents the fibres from spreading.

Portland-cement joints, on the other hand, require a space of $\frac{1}{4}$ in. between blocks, do not take up expansion, make the pavement noisy, develop a corduroy effect, and under heavy loads will split, permitting moisture to get at the foundation, besides requiring from 5 to 10 days to set, during which time traffic is excluded. Wide joints run transversely across the street and are filled with Portland cement, and paving cement with gravel or sand.

When a cement grout is used, the $\frac{1}{8}$ to $\frac{3}{8}$ in. joints are secured by laying laths 1 in. deep and of required thickness on the foundation between successive rows of blocks. The composition of the bitumen used in joints is 100 lbs. of pitch to $1\frac{1}{2}$ gals. of oil.

The disadvantage of wide joints is that they retain the dirt, increase the cost of cleaning, and are noisy.

EXPANSION JOINTS. To prevent heaving and to allow for the

natural change in volume produced in either soft or hard woods, whether treated or untreated, when exposed to the varying conditions of atmosphere, expansion joints are left next each curb as in asphalt-block or brick pavements. Such joints vary in width, depending upon the nature of the woods, and whether the blocks have been impregnated or not. They consist of a layer of sand placed between the blocks and the curb which is covered over with cement grout to prevent moisture from getting at the foundation. When the blocks have expanded as much as they are likely to, the grout and sand are removed and the space filled with cement grout or other material.

Untreated blocks will expand at the rate of about 5 times that of treated blocks, so that if in a pavement 30 ft. wide, 2 ins. at each curb should be left for expansion with treated blocks, and 10 ins. with untreated blocks. Creosoting tends to prevent this expansion, though about 1 in. for every 8 ft. in width is allowed even with such treatment.

GRADE. The best practice would seem to indicate that, as usually laid, a grade of from 3 per cent to 4 per cent should not be exceeded, though blocks have been used in London on grades as steep as 1 in 14 or $7\frac{1}{7}$ per cent and in 12 or $8\frac{1}{3}$ per cent.

Aside from tractive force, grade is an important factor in that wet weather causes the pavement to become slippery, offering a poor foothold, and requiring the use of sand. The frequency with which it must be scattered increases with the grade and is an additional expense in the item of maintenance.

On grades exceeding five per cent the blocks should be grooved or laid with wide joints which are filled with asphaltic cement and gravel, sand or cement grout as shown.

The transverse contour should conform in outline to the arc of a circle or parabola, and should drop from centre to sides an amount equal to one-eightieth to one-hundredth, the total width of wheelway.

CAUSES OF FAILURE. The chief causes of failure are a poor

foundation, difficulty in preventing the water from getting into the foundation at the curb, or leaking through the joints, and the splitting of the blocks.

To offset this, the foundation should be unyielding and impervious, the timber should be sound, well seasoned, and non-absorptive in character, and finally the joint filling should prevent moisture getting at the foundation.

VALUE OF PRESERVED WOOD FOR PAVEMENTS. Impregnated woods should be used only when the pavement wears out slowly, as the preservative protects wood from decay. If wear is rapid, then the wood wears out before it begins to decay, and it is therefore unnecessary to treat the block unless such treatment of the block adds to the strength and life of the pavement. Soft-wood pavements last 6 to 7 years, while hard-wood pavements, 10 to 12 years. Soft wood is more expensive to repair, though it is cheaper in its first cost.

Complete Specifications follow:

THE CITY OF NEW YORK, OFFICE OF THE PRESIDENT OF THE
BOROUGH OF MANHATTAN, BUREAU OF HIGHWAYS.

*Specifications for Regulating, Grading, and Paving or Repaving
with Wood-Block Pavement on a Concrete Foundation the
Roadway of from to together with the
work incidental thereto.*

1. EXTENT OF WORK.—This shall consist of (1) taking up the necessary curb, bridgestone, and such portions of the pavement that may be required to be removed for the proper laying of the pavement; (2) excavating the necessary portions of the roadway of subsoil, rock, or masonry where the same is above the proper subgrade or where the material underlying is not of proper character; (3) filling in depressions or openings in the roadway wherever said depressions are below the grade aforesaid or have been caused by the removal of improper material; (4) laying concrete

as a foundation, as has been designated; (5) resetting catch-basins and resetting or furnishing and setting city manhole heads to grade; (6) furnishing and setting and redressing and resetting the necessary curbstones and heading stones as required; (7) furnishing all the materials for and laying a wood-block pavement in the roadway; (8) readjusting and relaying pavement and resetting curbstones in the approaches of intersecting streets and avenues; all to be in accordance with the plan and profile of the said street, now on file in the Bureau of Highways, with workmanship and materials equalling in every respect the requirements of these specifications and the samples accepted.

2. Material furnished and work done not in accordance with these specifications, in the opinion of the engineer, shall be immediately removed and so replaced or corrected as to be in accordance therewith.

3. ESTIMATE OF QUANTITIES.—The estimates of the engineer of the quantity and quality of the supplies required, and the nature and the extent, as near as possible, of the work, are herein stated and set forth.

-square yards of wood-block pavement.
-cubic yards of concrete, including mortar bed.
-linear feet of new curbstone, furnished and set.
-linear feet of old curbstone redressed, rejointed, and reset.
-noiseless covers, complete for water manholes, to be furnished and set.
-noiseless covers, complete, for sewer manholes, to be furnished and set.
-square yards of old stone blocks to be purchased by contractor and removed.

4. PERSONAL EXAMINATION OF WORK.—Bidders must satisfy themselves by personal examination of the location of the proposed work, and by such other means as they may prefer, as to the accuracy of the foregoing statement, and they shall not, at

any time after the submission of their bid, dispute or complain of such statement or estimate of the engineer, nor assert that there was any misunderstanding in regard to the nature or amount of the work to be done.

5. **WORK TO COMMENCE ONLY WHEN ORDERED ON.**—No work will be paid for which is done before the contractor is ordered to proceed.

6. **PROSECUTION OF WORK.**—The work under this contract shall be prosecuted at and from as many different points, at such times, and in sections of such length along the line of the work and with such force as the president may, from time to time, during the progress of the work, determine, at each of which points inspectors may be placed to supervise the same.

7. **MATERIAL NOT TO OBSTRUCT TRAVEL.**—During suspensions all materials delivered upon, but not placed in the work shall be neatly piled so as not to obstruct public travel, or shall be removed from the line of the work at the direction of the engineer, and unless the materials be so removed by the contractor upon notice from the engineer, the materials may be removed by the president and the expense thereof charged to the contractor.

8. **ENCUMBRANCES.**—The contractor shall remove at his own expense, when directed by the engineer, any encumbrances or obstructions on the line of the work, located or placed there prior to or after its commencement.

9. **CONTRACTOR NOT TO DISTURB CITY MONUMENTS.**—The contractor shall not excavate around such city monuments and bench-marks as may come within the limits of, or be disturbed by the work herein contemplated nearer than five (5) feet or in any manner disturb the same, but shall cease work at such locations until the said monuments or marks have been referenced and reset or otherwise disposed of by the president. The necessary labor to remove, care for, and reset all such monuments and bench-marks shall be furnished without charge therefor by the contractor.

10. **MANHOLES, ETC., TO BE RESET.**—Such catch-basins, manhole frames and heads for sewers, waterpipes or other conduits belonging to the City on the line of the work as may be designated shall be reset to the new grades and lines by the contractor without extra charge therefor; and they shall be brought to such grades with brick masonry of the same thickness as that originally used, laid in hydraulic cement mortar and the cost thereof shall be included in the price bid for the contiguous pavement. Noiseless covers, complete, with interchangeable ventilating and non-ventilating fittings, for water and sewer manholes, of the design approved by the engineer, shall be furnished and set when required, in the manner above designated. All other manholes and boxes are to be reset to the proper grade, under the contractor's direction, by the companies owning the same.

11. The grades of all manholes and boxes must conform absolutely to that of the pavement surrounding, and the contractor shall supervise and see that all such resetting is substantially and accurately done in conformity with the foregoing, whether such resetting shall be done by his own men or by those from other companies, and he shall report in writing to the engineer any disinclination or negligence on the part of the latter to perform their work properly.

12. The contractor will be held strictly accountable for any variation or difference between the grades of reset manholes and boxes and that of the contiguous pavement, and any such difference existing on the completion of the work, or occurring during the maintenance period thereof, shall be corrected by the contractor at his own expense.

13. **MATERIALS TO BE REMOVED.**—**BRIDGESTONES TO BE LOADED.**—**OLD CURBSTONES.**—All old materials necessary to be removed in the preparation for paving, excepting manhole heads and boxes and the materials herein mentioned, shall be the property of the contractor, and shall be immediately removed by him off the line of the work. Bridgestones that are to be used

again shall be neatly piled, as hereinafter set forth, and such as are not so required, and all removed manhole heads and boxes, shall be loaded by the contractor into the carts or wagons of the Bureau of Highways and shall remain the property of the City. Old curbstones which cannot be utilized in accordance with the terms of these specifications shall become the property of the contractor, to be disposed of by him.

14. MATERIALS TO BE USED AGAIN.—PRICE FOR PAVEMENT TO INCLUDE REMOVAL.—Such other material which is specially suitable for use in the work shall be collected, piled, and utilized as directed by the engineer. All the work of removing and loading old material, as above, shall be included in the price bid per square yard of pavement.

15. EXCAVATION AND FOUNDATION.—The old paving blocks and other materials necessary to be removed shall be taken up and disposed of, as required, and the roadways excavated of all subsoil or other matter, be it earth, rock, or other material, to a uniform subgrade eight (8) inches below the top of the finished pavement, or to such other depth as the engineer may require. No ploughing will be allowed within six (6) inches of such subgrade, except by permission of the engineer.

16. SPONGY MATERIAL.—All spongy or objectionable matter disclosed by the excavations thus made shall be removed and the space filled with acceptable material, compacted by thorough ramming.

17. ROLLING.—UNSATISFACTORY MATERIAL TO BE USED.—When required, the entire roadbed, after having been brought to the necessary subgrade, shall be rolled with a steam roller until the surface is thoroughly compacted and the inaccessible portions shall be tamped, wetted, and tamped or rolled with a small roller and wetted, as may be directed. Material not admitting of satisfactory rolling shall be removed, and such new material as may be necessary to replace the same or bring the pavement to the proper grade shall be supplied and placed by the contractor

without extra compensation therefor. It shall be good, wholesome earth, free from foreign matter, and shall be placed in layers not more than six (6) inches in depth and rolled or rammed as above or as may be directed.

18. ROADBED SHAPING.—Great care shall be exercised in shaping the roadbed to secure a uniform surface parallel to, and the required depth below the given grade and crown, and the entire cost of such excavation and shaping shall be included in the price paid for pavement.

19. CONCRETE FOUNDATION.—On the roadbed thus prepared shall be laid a concrete foundation of the materials and thickness set forth in these specifications.

20. DELIVERY OF MATERIAL AND INSPECTION.—The materials for construction shall not be brought to or deposited on the street in quantities greater than is necessary for convenient working, and shall be so deposited as to cause the least possible obstruction to streets and sidewalks, as may be determined by the engineer. All new material of every description shall be carefully inspected after it is brought on the street, and all such not conforming in quality and dimensions to these specifications will be rejected and must be immediately removed from off the line of the work.

21. ASSISTANCE TO BE FURNISHED.—The contractor shall furnish such laborers as may be necessary to aid the engineer in such examinations, and in case he shall neglect or refuse so to do, such laborers as may be necessary will be employed by the president and the expense therefor will be deducted from and paid out of any money then due or which may thereafter become due to the said contractor under this agreement.

22. PILING OF MATERIAL.—All old and such new material as has been approved, except sand and broken stone, shall be neatly piled by the contractor on the front half of the sidewalk, on planks not less than one (1) inch thick if the same be flagged or otherwise improved, not within ten (10) feet of any fire hydrant and

with sufficient passageways to permit of free access from the roadway to each and every house on the line of the work.

23. Not until this has been done and the rejected materials removed entirely from the line of the work, each of which conditions must be faithfully fulfilled, will the contractor be permitted to proceed with the laying of the pavement.

24. OLD CURBSTONES THAT MAY BE RESET.—Old curbstones which can be redressed to a top width of not less than four and one-half ($4\frac{1}{2}$) inches, are not less than sixteen (16) inches deep, and are of the quality hereafter specified, shall be redressed, re-jointed, and reset, as directed below. All friable granite curbstones shall be rejected.

25. QUALITY, DIMENSIONS, AND DRESSING OF NEW CURBSTONES.—New curbstones shall be hard, sound, fine-grained, and uniform-colored bluestone, shall be free from seams and other imperfections, and shall be equal in quality to the best North-River bluestone. They shall be sixteen (16) inches in depth, from three and one-half ($3\frac{1}{2}$) to eight (8) feet in length, and not less than five (5) inches in thickness (except as noted for bottom of curb), with square ends of the full average width. The face for a depth of nine (9) inches and the top, on a bevel of one-half ($\frac{1}{2}$) an inch in its width of five (5) inches, shall be dressed to a surface, which shall be out of wind and shall have no depressions measuring more than one-quarter ($\frac{1}{4}$) of an inch from a line or straight edge of the same length as the curbstone. The remainder of the face shall be free from projections of more than one-half ($\frac{1}{2}$) an inch, and the back for three (3) inches down from the top shall have no projections greater than one-quarter ($\frac{1}{4}$) of an inch measured from a plane at right angles to the top. The bottom of the curb shall be rough-squared with a width of not less than three (3) inches.

The sample of the curbstone showing the dressing and the jointing required can be seen at the office of the chief engineer of the Bureau of Highways.

26. JOINTING.—For the full width of the stone for a distance down the same as the above-mentioned depth of dressed face from the top, and therebelow to the bottom for a width of two (2) inches back from the face, the ends shall be squarely and evenly jointed. In no case shall the ends of the curbstones abutting basin-heads be bevelled off or reduced in width, but recesses shall be neatly cut in such basin-heads without charge therefor, to give square, close joints for the width of the stone.

27. SETTING.—Each curbstone shall be set truly to grade and line and on a face batter of one (1) inch in its depth, or vertically as shall be directed: it shall be firmly bedded and tamped, and the rear to the top back filled and tamped with clean, dry, gritty earth or coarse sand, free from rock fragments, or as hereinafter more particularly set forth, and the vertical face joints of all curbstones shall be flush pointed firmly with good mortar of one part of Portland cement and two of sand from the top of the curb to the top of the foundation of the wood-block pavement.

28. CORNER CURBSTONES.—Curved curb for corners shall be cut with true radial joints and set accurately to a radius of six (6) feet in three (3) foot lengths, unless otherwise required. It shall be paid for as straight curb, and must comply in all respects with the above requirements therefor.

29.—The cost of excavation necessary for curb-setting shall be included in the price paid per linear foot of curb, and no compensation therebeyond shall be made or allowed.

30. CURB ON CONCRETE.—When specified, the curbstone aforesaid shall be set on a concrete foundation, and the price submitted per linear foot for new curbstone shall include the furnishing of the stone and all the excavations necessary for the concrete foundations.

31. CONCRETE BED FOR CURBSTONES.—The concrete foundation for curbstone shall not be less than six (6) inches thick and eighteen (18) inches in width, and be of the materials and proportions hereinafter described except that the broken stone shall

not be less than one-quarter ($\frac{1}{4}$) nor more than one and one-half ($1\frac{1}{2}$) inches maximum dimensions; the curb to be immediately bedded on the centre thereof with a bearing for its full length as soon as the concrete is laid, and it shall be at once backed up with concrete for a width of six (6) inches, extending from the bottom bed to within four (4) inches of the top of the stone. The concrete so used will be paid for at the general price bid per cubic yard for concrete.

32. FRONT CONCRETE.—Simultaneously with the backing up in the rear, the concrete in front of the curb shall be carried up, for the exposed width of the bottom bed, to the elevation of the bottom of the paving foundation, and so much of said paving foundation itself as may be necessary, for a width not less than six (6) inches from the curb, shall be immediately laid to serve as a support for the curbstones. When set the corners of the curb at the top shall be a straight and true line, and the upper and face surfaces a plane surface.

33. IN FRONT OF CONCRETE WALKS.—When curb is set in front of a monolithic, cement, or concrete sidewalk, the space between the curb and sidewalk foundation shall be completely filled with concrete, similar to that on which curb is set, to within two (2) inches of the top; the remaining space to be filled with Portland cement of the quality hereinafter specified, mixed with equal parts of crushed stone used for the wearing surface of such walks. The concrete used for foundation and setting curbstones will be paid for by the cubic yard, the same as the price bid for concrete, and the dimensions will be based upon these hereinbefore stated.

34. REMOVAL OF FLAGSTONES.—MONOLITHIC WALKS.—BACK-FILLING.—The front course of flagstones when not over four (4) feet in width interfering with the work of curb-setting shall be picked up and be set back, and after the curb has been set and thoroughly backfilled, they shall be fitted in their original position and the cut edge be retrimmed and rejointed to a true

line to give a joint, when possible, not more than one-half ($\frac{1}{2}$) an inch wide at the back of the curb and be so relaid to the new curb grade when such grade does not differ more than five (5) inches from that originally existing; the stone to be thoroughly bedded and the joints cemented as herein set forth. Stone of unusual size and those containing coal-hole openings, ventilation, or light castings shall in no case be disturbed, but the front edge shall be rejointed to line, as above in place. Monolithic walks shall be carefully cut off to a true line, five and one-half ($5\frac{1}{2}$) inches back of, and parallel to the new curb line, and for use in such locations curbstones shall be selected of as near as possible a uniform width throughout its depth that the foundation of the walk may not be unnecessarily damaged. The entire space between back of curb and such walks, or stones that are left in place (except where curbstones are to be set in concrete as above described), shall be backfilled with fine sand, free from gravel and stones, to within two (2) inches of the top of the curbstones, water being freely used to settle and compact the same. The remaining space shall be filled with Portland cement mixed with sand or stone as used for such walks, to be neatly trowelled to place, and the contact surfaces of stones and walks shall be made clean and wet while filling and trowelling the said two (2) inches.

35. Any damage done by the contractor to sidewalks in curb-setting, handling, or in the storage of materials shall be made good by him, at his own expense, as shall be directed by the engineer.

36. NEW FLAGGING, QUALITY AND DIMENSIONS.—DRESSING OF FLAGSTONE.—New flagging furnished to replace any broken shall be of bluestone of even color and best quality, and satisfactory to the president, not less than three (3) inches thick, even on its face, free from seams, flaws, drill-holes, or discoloration, measuring not less than four (4) feet wide, and containing not less than twelve (12) superficial feet or of the same size as that

broken, as shall be directed; the stones to be chisel-dressed, with sides parallel, on the four edges a distance down of one (1) inch from the top and at right angles thereto; except that, in sidewalks where stones of superior dimensions or quality are broken, the replaced stone must be in length and width not less than the old stone and be of the same quality of material.

37. LAYING OF FLAGSTONE.—CLEARING UP.—All flagging to be relaid shall be firmly and evenly bedded to the grade and pitch required, on four (4) inches of steam ashes, clean, gritty earth or sand, free from clay or loam, and the work brought to an even surface, with all joints close and thoroughly filled (except around monuments and trees), for the full depth with cement mortar, composed of equal parts of the best Portland cement and clean, sharp sand, and left clean on the surface; and all earth, débris, and surplus material shall be removed from each block and the sidewalks swept clean, as soon as the work thereon has been completed.

38. HEADING STONES.—Wherever the new pavement abuts pavement of a different character, and wherever directed to do so, the contractor shall put down bluestone heading stones at least three (3) feet long and one (1) foot deep, and set with full bearing on a bed of concrete nine (9) inches wide and six (6) inches deep, of the quality hereinafter described. These heading stones shall be of good, sound bluestone, free from lamination or seams. They shall be dressed square on top to a good surface, free from irregularities, and to a uniform width of not less than four and one-half ($4\frac{1}{2}$) inches. The ends shall be joined square down to give close joints, and the bottoms shall be nowhere less than three (3) inches wide and be cut to give a full, square bearing throughout, and the sides shall be free from bunches. These stones shall be maintained by the contractor, and they will be paid for as wood-block surface.

39. WOOD-BLOCK PAVEMENT.—(1) The material to be treated shall be wood blocks, which may be either of Southern Long-leaf

Yellow Pine, Southern Black Gum, Norway Pine, or Tamarac, not less than ninety per cent of heart, of a texture permitting satisfactory treatment as hereinafter specified, and is to be subject to inspection at the works in the stick before being sawed into blocks.

(2) All blocks shall be of sound timber, free from bark, loose or rotten knots, or other defects which would be detrimental to the life of the block or interfere with its laying. No second-growth timber will be allowed.

(3) The paving blocks cut from the lumber above specified shall be well manufactured, truly rectangular, and of uniform dimensions. Their depth (parallel to the fibre) shall be three and one-half ($3\frac{1}{2}$) inches. Their length shall be not less than six (6) or more than ten (10) inches, and their width shall be not less than three (3) nor more than four (4) inches, but all blocks used in any one contract are to be of the same width and of the same timber. Their depth and width shall not vary more than one-eighth ($\frac{1}{8}$) inch from the dimensions specified for any one contract.

(4) The blocks are to be treated throughout with an anti-septic and water-proof mixture, seventy-five per cent of which shall be creosote or heavy oil of coal tar conforming to the specifications hereinafter set forth, and twenty-five per cent of which shall be resin conforming to the specifications hereinafter set forth. All parts of each individual block shall be thoroughly treated, and not less than twenty (20) pounds of the mixture per cubic foot shall be injected.

(5) In preparing the blocks to receive the creosote mixture, they shall be placed in an air-tight cylinder, in which dry heat, or heat produced by superheated steam, is maintained and raised to a temperature of 215° Fahrenheit, for 1 hour, for the purpose of expelling moisture; the heat is then to be increased until it has reached 285° Fahrenheit, this heat being maintained for a period of 3 hours, or until the block is completely sterilized. Applica-

tion of heat is then to be stopped and the temperature of the cylinder allowed to fall for 1 hour, or until same has been reduced to 250°. A vacuum is then to be applied until about 26 ins. is reached, and while under this vacuum the creosote mixture is to be run into the cylinder at a temperature of from 175° to 260°, after which hydraulic pressure of not less than 200 lbs. per sq. in. is to be maintained and raised until the individual blocks are treated throughout.

(6) The creosote oil is to conform to the following specifications when tested, as follows:

(7) The gravity at 68° Fahrenheit shall be not less than 1.12. When distilled in a retort with the thermometer suspended not less than 1 in. above the oil, it shall lose not more than thirty-five (35) per cent up to 315° centigrade, and not more than fifty (50) per cent up to 370° centigrade. The oil is to be free from adulteration; it must not be mixed with or contain any foreign material.

(8) The resin is to be solid resin obtained from pine. It is to be reduced to a fine dust by grinding, and then incorporated with the hot creosote oil in a suitable mixing tank until the proper proportions are secured.

(9) After treatment the blocks are to show such water-proof qualities that, after being dried in an oven at a temperature of 120° for a period of twenty-four hours, weighed and then immersed in clear water for a period of twenty-four hours and weighed, the gain in weight is not to be greater than three (3) per cent.

40. ANALYSIS OF TREATED BLOCK.—Fine turnings from the block shall be placed in a suitable extraction apparatus and the oil completely extracted therefrom with ether or carbon bisulphide. The oil so extracted shall be placed in a suitable still and distilled. The portion up to 120° centigrade, consisting of the solvent, is to be collected apart. The oil shall then be distilled up to 370° centigrade. The creosote oil thus obtained must con-

form in all respects to the requirements of Paragraph 39, Sub-division 7.

41. INSPECTION OF MATERIAL.—The engineer shall have tests and examinations made at the contractor's works of the materials and blocks proposed to be used, and reject any or all of such materials and blocks as he may consider not to be in compliance with these specifications. The borough president shall appoint an inspector at the expense of the contractor, who shall inspect the lumber and other materials used in the manufacture of the blocks and the treatment of the blocks; and he shall reject any of such material and blocks as he may consider not to be in compliance with these specifications.

42. INSPECTION.—The blocks will be carefully inspected after they are brought on the line of work, and all blocks which in quality and dimensions do not conform strictly to the requirements will be rejected and must be immediately removed from the line of work.

43. CEMENT.—The cement shall be of the best quality of American Portland, samples of which must be submitted at least ten (10) days (holidays and Sundays excluded) before using, for the inspection and approval of the chief engineer, and no change from such approved brand shall thereafter be made without the submission and approval of samples. It will be required that the various deliveries shown by samples taken from the work during its continuance shall exhibit qualities equal or superior to those developed by the samples submitted as aforesaid.

44. QUALITY.—TENSILE STRENGTH.—All cements shall be freshly ground and of a uniform quality, color, and weight, and briquettes of one (1) square inch section shall develop or exceed the following tensile strength:

Neat, one hour air, twenty-three (23) hours in water, 200 lbs.; neat, one day air, six (6) days in water, 400 lbs.; neat, one day air, twenty-seven (27) days in water, 480 lbs.; one of Portland, three (3) of sand, one day air, six (6) days water, 150 lbs.

45. CONCRETE.—PROPORTIONS OF MATERIALS.—THE UNIT OF MEASURE.—The concrete shall be composed of one (1) part of cement, three (3) parts of sand, and six (6) parts of broken stone, but should the proportion of voids in the stone be such that a greater or less quantity of stone be required to give satisfactory results, the amount of broken stone shall be increased or decreased to the extent directed by the engineer upon any particular piece of work. The unit of measure shall be the barrel of cement as packed by and received from the manufacturer.

46. SAND AND BROKEN STONE.—TO BE STORED ON PLATFORMS.—The sand shall be clean, coarse, and sharp, and be free from loam or dirt. The broken stone shall be of trap, granite, or limestone, or such other stone taken from the line of the work as shall be satisfactory in the judgment of the engineer. It shall be entirely free from dust and dirt, and be of graded sizes that will pass in any direction through a revolving circular screen having holes two and one-half ($2\frac{1}{2}$) inches in diameter, and be retained by a screen having holes one (1) inch in diameter. The sand and stone must be placed upon board platforms and kept free from dirt, and the cement shall be properly blocked up and protected from dampness.

47. SIZE OF BATCH.—MIXING.—USE OF MIXING MACHINE.—Concrete, unless machinery be used, shall be mixed in batches, containing not more than one (1) barrel of cement with the requisite proportion of other material, on suitable tight platforms, not less than twelve (12) feet by twelve (12) feet in size. The cement and sand shall be thoroughly mixed dry after which the broken stone, having first been wetted, shall be added. The whole mass shall then be turned and worked by skilled laborers, until a resultant is obtained, with the stone uniformly distributed. In shovelling, the material must be lifted clear of the board. If a concrete mixing machine be used, the cement and sand shall be mixed as above and precautions taken to insure the proper

proportion of each of the materials, so that the resultant mixture shall be uniform in quality.

48. LAYING.—CONCRETE SURFACE TO BE SCABBLED.—The concrete shall be placed in position, and there rammed with proper rammers until thoroughly compacted. The whole operation of mixing and laying each batch must be performed as expeditiously as possible, and in no case shall concrete be used which has been mixed more than one-quarter ($\frac{1}{4}$) of an hour. The concrete shall be protected from the weather until set, and should it at any time be considered by the engineer to be poorly mixed or not to be setting properly, such portions shall be taken up and replaced with satisfactory material. Sufficient time, of which the engineer shall be the judge, shall be allowed for the concrete to set before the pavement is laid thereon. Before laying concrete to connect with, rest upon, or overlap any concrete previously laid, the entire surface of contact of the latter shall be swept and washed clean of all dirt and mortar particles and, when deemed necessary, shall be satisfactorily scabbled.

49. NO TRAFFIC ON CONCRETE.—No horses, carting, or wheeling shall be allowed on the concrete until the same has thoroughly set, *and then only on planks* furnished and laid by the contractor. By car tracks the contractor shall provide men to pass cars thereover.

50. THICKNESS AND TESTING.—The concrete foundation shall be four and one-half ($4\frac{1}{2}$) inches thick, including a mortar top surface of one-half ($\frac{1}{2}$) inch in thickness, the concrete proper being four (4) inches thick, and shall withstand such tests as the engineer may deem necessary, and the contractor shall furnish such samples as may be required for the purpose.

51. CEMENT MORTAR BED.—Upon the surface of the concrete foundation shall be spread a bed of cement mortar one-half inch in thickness. This mortar surface shall be composed of a slow-setting Portland cement and clean, sharp sand, free from pebbles over one-quarter ($\frac{1}{4}$) inch in diameter, and mixed in the

proportion of one part cement to four parts of sand. This mortar top shall be thoroughly rammed into place with concrete rammers until all the unevenness in the concrete shall be taken up, and shall then be "struck" to a true surface exactly parallel to the top of the finished pavement.

52. On the surface of the concrete foundation before the mortar bed is laid shall be set strips of wood four (4) inches wide by one-quarter ($\frac{1}{4}$) inch thick, or strips of steel four (4) inches wide by not less than one-eighth ($\frac{1}{8}$) inch thick, and of the greatest length convenient for handling. These strips shall be carefully set parallel and about eight (8) or ten (10) feet apart, running from curb to curb, and be embedded in mortar throughout their length so that the top surface shall be three and one-half ($3\frac{1}{2}$) inches below and parallel to the grade of the finished pavement. The space between two strips having been filled with mortar, a true and even top surface shall be struck by using an ironshod straight edge on the strips as a guide, and as soon as the bed has been struck, the strip which would interfere with laying the blocks shall be removed and its place carefully filled with mortar with a trowel.

53. If the width of the roadway be such that the laying of blocks on a complete section cannot be completed before the mortar takes its initial set, the strips may be placed parallel to the curb, and templates cut to the curve of the desired crown shall be used on these strips to strike the bed.

54. METHOD OF LAYING.—On this mortar surface spread and smoothed as above to the proper crown and grade, the blocks are to be laid with the grain vertical and at such an angle with the curb as the engineer may direct. They shall be laid in parallel courses with as tight joints as possible, each block being firmly bedded in the mortar bed so as to form a true and even surface. A one-half inch paving expansion joint shall be used along each curb and across the street every one hundred feet.

The joints shall then be filled with cement grout composed of

2 parts clean sand and 1 part of Portland cement, mixed to a perfectly liquid form, and the surface of the block shall be slushed with same and the joints swept until they are completely filled. The surface shall then be covered with $\frac{1}{2}$ in. of screened sand.

55. GROOVED BLOCKS.—Where wood-block pavement is laid on streets or parts of streets having a gradient of more than three per cent the blocks shall be not less than six (6) inches nor more than ten (10) inches long, and the upper edge of each block shall be cut away for a width of one-fourth ($\frac{1}{4}$) inch and a depth of one (1) inch, so as to provide transverse grooves of that width and depth between each course of block when the blocks are laid in place; or such other construction shall be used as will, in the opinion of the engineer, provide an equally good foothold for horses.

56. CUTTING CLOSURES.—Nothing but whole blocks shall be used except in starting a course or in such other cases as shall be specially permitted by the engineer, and in no case shall less than one-third of a block be used in breaking joints. Closures shall be carefully cut and trimmed by experienced men, the portion of the block to be used to be free from check or fracture and the cut end to have a surface normal to the top of the block and be cut at the proper angle to give a close, tight joint.

57. LAYING.—Each course of blocks shall be of uniform width and depth, with all joints close and the end joints broken by a lap of at least four (4) inches, and, while laying, the pavers must stand on those already laid. Any lack of uniformity in the surface or unevenness in the blocks must be immediately corrected by taking up and relaying the blocks, and blocks fractured or broken shall be replaced with perfect ones before any sand is spread over the surface.

58. SAND COVERING.—When laid, the blocks shall be covered with clean, fine sand, entirely free from loam or earthy matter, perfectly dry and screened through a sieve having not less than

twenty (20) meshes per linear inch, the sand to be left on the surface until such time when, if required by the engineer, the pavement shall be swept clean for final inspection and any defects then noted shall be remedied.

59. **READJUSTMENT OF ADJOINING PAVEMENT.**—The curbstones and gutters of the adjoining pavements, and all pavements abutting the new work, shall be readjusted and brought to the new grades and lines to the extent deemed necessary by the engineer, and such readjustment of curb and pavement shall include rejointing, resetting, and relaying as herein provided, all without charge therefor.

60. In readjusting such abutting pavements, all imperfect stones shall be discarded and only those of regular shape used and before the old pavement of the street being paved shall have been removed, the contractor shall select therefrom enough perfect stones, and preserve the same until needed, to make up any deficiencies. On the contractor's failure so to do, he shall provide such extra necessary stones at his own expense and to the satisfaction of the engineer.

61. The stones shall be laid in straight and regular courses, with close end joints broken by a lap of at least three inches. The joints between courses shall be close except when gravel filling is to be used, and the courses shall be carried parallel to the existing courses; any differences in alignment between such courses and the header shall be corrected at the header by neatly trimming the blocks. None but stones of the same width shall be used in the same course except where trimming is necessary.

62. All stones shall be relaid on a full bed of sand and be thoroughly rammed to a firm unyielding bearing and to a uniform surface, the joints to be brushed full of sand.

63. When the pavement is to be relaid on a concrete foundation with joint filling, such foundation, if required by the engineer, shall be removed and relaid, or be added to with concrete, as may be necessary; all other detail to be in accordance with the cur-

rent specifications for similar work in use in the Bureau of Highways.

64. REMOVAL OF SURPLUS MATERIALS, RUBBISH, ETC.—All surplus materials, earth, sand, rubbish, and stones are to be removed from the line of the work, block by block, as rapidly as the work progresses; all material covering the pavement and sidewalks shall be swept into heaps and immediately removed from the line of the work; and unless this be done by the contractor within forty-eight hours after being notified so to do, by written notice to be served upon the contractor, either personally or by leaving it at his residence or with any of his agents on the work, to the satisfaction of the president, the same shall be removed by the said president and the amount of the expense thereof shall be deducted out of any moneys due or to grow due to the contractor under this agreement.

65. SWEEPING AND SPRINKLING.—At all times during the prosecution of the work, such materials as may be placed on the sidewalk shall be piled in the manner heretofore set forth, and the contractor shall keep the footway clean by sweeping. When such material is removed, the sidewalk must be immediately swept clean by the contractor, and when public or local inconvenience is caused by dust, the contractor shall water any piles or surfaces of earth or the sidewalks or pavement foundation during sweeping, when and where necessary or whenever required by the engineer so to do.

66. PATENTED ARTICLES.—That whenever or wherever an article or any class of materials is specified by the name of any particular patentee, manufacturer, or dealer, or by reference to the catalogue of any such manufacturer or dealer, it shall be taken as intending to mean and specify the article or materials described, or any other *equal thereto* in quality, finish, and durability and equally as serviceable for the purposes for which it is (they are) intended. Nothing in these specifications shall be interpreted or taken to violate the provisions of Section 1554 of

the Greater New York Charter, which provides that "except for repairs no patented pavement shall be laid and no patented article shall be advertised for, contracted for, or purchased, except under such circumstances that there can be a fair and reasonable opportunity for competition, the conditions to secure which shall be prescribed by the Board of Estimate and Apportionment."

INDEX

- ABANDONMENT of contract, New Jersey practise in case of, 65
Alvord, J. W., on brick pavements, with illustrations, 195-197
Asphalt, characteristics and varieties of, 222-224
 liquid, 249
 pavement, block, 232, 233
 block, composition and treatment of concrete for, 267-269
 block, curbing for, 259, 260
 block, cutting closures, 269, 270
 block, New York City specifications for, 254-272
 block, qualities of cement for, 266
 block, rolling of, 258
 block, size and composition of blocks, 264, 265
 tensile strength of, 266
 block, tests for, 265, 266
 block, treatment of flagstones, 262, 263
 block, treatment of manholes, catch-basins, etc., 256
 block, treatment of monolithic walks, 262
 mixture, composition and properties, 248
 proper, definition, 247
 sheet, binder for, 228
 sheet, broken stone for, 242, 243
 sheet, cement and concrete for, 242
 sheet, composition of mixture, 250
 sheet, crown for, 231, 232
 sheet, flagging for, 239-242
 sheet, foundation for, 227, 228
 sheet, grade and crown, 231, 232
 sheet, heading stones for, 242
 sheet, process of laying, 251
 sheet, sand for, 229, 242
 sheet, specifications for, 233-253
 sheet, stone dust for, 229
 sheet, wearing surface, 229-231
 traction tests on, by Iowa State University, 13
 pavements, 222 *et seq.*
 advantages and disadvantages, 226
 artificial, 226
 natural, 225

- Asphaltic cement for sheet asphalt pavement, 230, 231
 properties and requirements, 249, 250
- Asphalts, rock, requirements of, when used, 251
- Axle-trees and wheels, arrangement of, to prevent ruts, 118, 119
- BACKFILLING in block asphalt work, 262
- Baker, table showing effect of grade and road covering on load, 23
- Baker's coefficient of axle friction, 2
- Ball mill in stone-dust preparation for briquettes, with illustration, 99, 100
- Batch, size of, in mixing concrete for block asphalt work, 267
- Belgian-block pavement, 177, 178
 origin of name, 177
- Bids, gravel road, New Jersey requirements, 61
 New Jersey practice, 134
- Binder for gravel roads, 47
 for sheet asphalt pavements, 228
- Binders for macadam or telford, New Jersey practice, 130
- Binding material for macadam road, Macadam's opinion, 124
- Black, Prof. A., article on tests of road stone, 81-91
- Block asphalt pavement, see Asphalt pavement, block
- Blocks, asphalt, size and composition, 264, 265
 tests for, 265, 266
 city, desirable size of, 164
- Brick for paving, sizes and qualities, 195-197, 214
 paving, testing for hardness, Moh's scale, 198
 pavement, advantages of, 194, 195
 J. W. Alvord on, 195, 197
 traction tests on, Iowa State University, 13
 pavements, curbing, 210, 211
 "Directions for Laying," etc., recommended by the National Pav-
 ing Brick Manufacturers Association, 209-221
 expansion cushion for, 217
 foundation for, 202, 203, 212
 history, description, etc., 194 *et seq.*
 imperviousness and density of material, 202
 intersections, with illustrations, 206-208
 joint filling for, 204
 laying the brick, 205, 206, 215
 rolling and tamping, 218
 testing for strength of material, 200, 201
 testing for toughness of material, 198-200
 machine for, 199
- Bridges, culverts, suspension work, New Jersey practice, 64
 etc., in stone-road making, New Jersey requirements, 138
- Bridgestones for stone pavements, 243, 244

- Bridgestones, New York City specifications, 189
 cement for, 190
- Briquettes in stone tests, descriptions of, and illustrations of machines for making, 94-101
- Broken-stone roads, description and treatment, 70
 roads, varieties of, 70
- Burnt-clay roads described, 143
- CARRIAGEWAY, width of, 165, 166
- Catch-basins, New York City practice, 184
- Cement and concrete for sheet asphalt pavements, 242
 asphaltic, properties and requirements, 249, 250
 for block asphalt work, qualities of, 266
 tensile strength of, 266
 wood pavements, New York City requirements, 295
 paving, New York City practice, 191
 temperature, etc., 246
 tothing, 246
- Cementation tests of stone for roadmaking, 94-102
- Central Park, New York city, gutters in, 170
- Charcoal roads, construction of, 151, 152
- Check accompanying bids, New Jersey requirements, 135
 bids in gravel road specifications, New Jersey, 62
- Chemical treatment of blocks for wood pavement, 278
- Chert in binder for gravel roads, 48
- Chesapeake Bay district, shell roads in, 150
- City blocks, desirable size of, 164
 streets, see Streets
- Clay on gravel roads, 47
- Cleaning various pavements, comparison of labor required, illustration, 197
- Closures, cutting, in block asphalt work, 269, 270
 in wood paving, 299
- Coal-slack roads, 151
- Cobblestone pavements, 176, 177
- Concrete and cement for sheet asphalt pavement, 242
 for block asphalt work, composition and treatment of, 267-269
 wood pavements, New York City requirements, 296, 297
 foundation for curbstone, 186, 187
- Construction of gravel roads, 50-53
- Contour of earth roads, with illustrations, 41, 42
- Contract, subletting, New Jersey, 67
- Contractor, liabilities of, New Jersey specifications, 136, 137
- Corduoy roads described, 143, 144
- Covering, thickness of, for stone road, 108-110
- Cross-section of stone road, 113

- Crown of city streets, treatment of, 172
 earth roads, contour and treatment of, with illustrations, 41, 42
 gravel roads, 50
 sheet asphalt pavement, 231, 232
 stone road, amount of, 113
 stone road, effect of grade on, table, 114
- Crushing resistance of stone, determination of, 102
- Culverts on earth roads, employment of, 39
- Curbing for block asphalt pavement, 259, 260
 brick pavements, 210, 211
- Curbs and gutters for city streets, with illustrations, 169-172
- Curbstones for stone pavements, New York City practice, 185, 186
- Cushion, expansion, for brick pavements, 217
- DE CAMP machine for oiling roads described and illustrated, 147, 148
- Definition of asphalt pavement proper, 247
- Department of Agriculture, report to, of repairs to macadam roads, 114-122
 Agriculture tests at Cotton States Exhibition in Atlanta, 14-18
- Deval machine in abrasion tests, 91
- Diagonal system of city streets, Haupt on, with illustrations and formulas, 159-164
- Dirt roads, see Earth roads
- Ditches for gravel roads, New Jersey practice, 60
 side, for earth roads, 39, 40
- Drags, varieties and uses of, with illustrations, 31, 32
- Drainage of earth roads, side ditches as factor, 39, 40
 gravel roads, 49, 50
 stone roads, New Jersey requirements, 133, 137
 streets, 169-173
 subsurface, on earth roads, 32-38
- Drains for earth roads, details of, illustrations, 33, 35
 tile, uses of, on earth roads, with table of sizes, 35, 36
- Duluth, street grades in, 167, 168
- Dupuit and Morin experiment on speed and resistance, 9
- Dust, inorganic, for sheet asphalt pavement, 250
- Dwellings, entrances or driveways to, New Jersey practice, 132
- Dynamometer, self-recording, used in Missouri road tests, 7
- Dynograph described, with illustrations, 19, 20
- EARTH roads, clay, treatment of, with illustrations, 41
 construction of, 26 *et seq.*
 ditching for various surfaces, 41, 42
 drainage as factor in maintenance, 25, 27, 28
 gravel on, benefit of, 53
 maintenance and repair, 44, 45

- Earth roads, Missouri tests on, 7, 8
 slope of, with table, 43
 thorough consideration of, 24
 use of rollers on, 32
 width and right of way, with illustration, 42
- Earthwork, excavation, etc., 43
- Embankment in gravel roads, New Jersey practice, 57
- Engineer, selection and duties of, New Jersey, 65
- Excavation in gravel roads, New Jersey practice, 57
- Expansion, allowance for, in wood pavements, 280, 281
- FAILURE, causes of, in wood pavements, 281, 282
- Field stone for road-building, 105
- Filler for brick pavements, 204, 205, 218
- Fillers for stone-pavement joints, 182
 New York City practice, 182
 wood pavement joints, 280
- Flagging for sheet asphalt pavement, 239-242
- Flagstones, treatment of, in block asphalt work, 262, 263
- Foundation for brick pavements, 202, 203, 212
 sheet asphalt pavement, 227, 228
 wood pavement, 279
- France, treatment of trees in street design, 174
- Friction, axle, considered, with formula, 1, 2
- GOVERNMENT (U. S.) tests in traction resistance, 12, 14-18
- Grade and crown for sheet asphalt pavement, 231, 232
 Baker's table showing effect of, on load, 23
 effect of, Massachusetts Commission report on, 21
 of, on crown of, stone road, table, 113
 of, on tractive force, with table and illustration, 21, 22
 in wood pavements, 281
 longitudinal, as factor in maintenance of stone roads, 117
 resistance, to estimate, 20
- Grades at street intersections, 168
 street, importance of, 167
- Grading of gravel roads, 50
 gravel roads, New Jersey practice, 57
- Granite for road-building, 105
- Granite-block pavement, 178-193
 pavement, kinds of stone used, 179
 size of blocks, 179, 180
 pavements, New York City specifications, 183-193
 pavements, size of blocks, New York City practice, 190
 cement for, 190, 191

- Gravel, benefit of, on earth roads, 53
roads, binder, selection of, 47
 chert in binder, 48
 clay on, 47
 crown of, 50
 drainage of, 49, 50
 general study of, 46 *et seq.*
 grading of, 50
 maintenance, 53, 54
 methods of construction, 50-53
 Missouri tests on, 7
 New Jersey practice, 55-69
 repairs of, 54, 55
 screening for, 49
 specifications of New Jersey Commissioner, 55-69
 surface construction, 50, 51
 trench construction of, 52, 53
 vs. macadam, comparison, 55
 selection of, 46 *et seq.*
- Grooved blocks in wood paving, 299
- Gutters and curbs for city streets, with illustrations, 169-172
 or side ditches, stone roads, New Jersey practice, 133
- HARRISON, E. G., report on repairs of macadam roads, 114-122
- Haupt, Lewis M., on diagonal system of city streets, 159-164
- Heading stones for sheet asphalt pavement, 242
- Herring and Rosewater, plan of intersection grades, 168
 Rudolph, table of effects of surface on tractive force, 11, 12
- INORGANIC dust for sheet asphalt pavement, 250
- Intersections, brick, pavements with illustrations, 206-208
 of streets, grades at, 168
- Iowa State University tests on brick and asphalt pavements, 12, 13
- JOINTS in wood pavement, filling for, 280
 stone pavements, fillers for, 182
- LAYING sheet asphalt pavement, process of, 251
 wood pavement, 279-282
 pavements, New York City method of laying, 298, 299
- Liabilities of contractor, New Jersey specifications, 62, 63
- Lifting of stone road, when and how it should be done, 124
- Limestone for road-building, 105
- Liquid asphalt, 249
- Loads, comparison of, on various pavements, illustration, 196

- Loam, gravelly, on earth roads, with illustration, 41
sandy, on earth roads, with illustration, 41
- Location of city streets, 156, 157
- Lots, size of, 165
- MACADAM, his definition of the road, with illustration, 70, 71
opinion of binding material, 124
material, abrasion machine for, described and illustrated, 92
pavement, Missouri tests on, 7
modern, 74
New Jersey practice, 130
road, binding material for, Macadam's opinion, 124
effects of various rollings, 111, 112
roads, E. G. Harrison's report on repairs, 114-122
vs. gravel, comparison, 55
surface, excavating and preparing roadbed, trenching, illustrated, 106, 107
- Machine, briquette, for stone tests, illustrated, 95, 97
De Camp, for oiling roads, described and illustrated, 147, 148
for testing brick for paving, 199
old Deval, in abrasion tests, 91
road, grading the subgrade of stone road, illustrated, 75, 77
- Maintenance of earth roads, 44, 45
gravel roads, 53, 54
stone roads, longitudinal grade as factor in repairs, 117
stone roads, ravelling as factor in, 119, 121, 122
stone roads, ruts as factor, 118
stone roads, trash or rubbish as factor, 120, 121
- Maltha, when it may be used, 249
- Manhole, covers, heads, etc., 184
- Manholes, catch-basins, etc., in block asphalt job, 256
- Maryland collects only half tolls from drivers of broad-tired vehicles, 7
shell roads in, 150
- Massachusetts Commission absorption test of stone, 104
method of stone cementation tests, 95, 96
report on effect of grade, 21
reports on tire widths, 6
experience in use of trees on highway, 175
practice in laying stone, 110
in surfacing for stone roads, 108, 109
- Materials in gravel roads, New Jersey practice, 59
old, removal and ownership of, New York City practice, 184
patented, procedure in case of, 272
- McNeill, Sir John, table of effects of surface on tractive force, 10
- Mill, ball, in stone-dust preparation for briquettes, described and illustrated,
99, 100

- Miscellaneous roads described and illustrated, 143 *et seq.*
- Missouri Experiment Station tests on different road surfaces, 7-9
- Mixture for sheet asphalt pavement, composition of, 250
- Moh's scale for testing hardness of brick, 198
- Monolithic walks, treatment of, in block asphalt work, 262
- Monuments, city, how treated by contractor in New York City, 185
- Morin and Dupuit experiment on speed and resistance, 9
- M., experiments on diameter of wheel, 5
- Mortar bed by car tracks, New York City, composition of, 192
- treatment of, 192
- NATIONAL PAVING BRICK MANUFACTURERS ASSOCIATION**, "Directions for Laying," etc., 209-221
- New Jersey allows tax rebate to owners of wide-tired vehicles, 6
- practice and specifications for gravel roads, 55-69
- practice in surfacing stone roads, 109
- practice in width of stone road, 112
- specifications for stone roads, 126-142
- New York City specifications for granite-block pavements, 183-193
- City, street grades in, 167
- OIL** for roads, quantity required, 149
- for roads, selection and application, 146 *et seq.*
- petroleum, for asphaltic cement, requirements of, 249
- Oiled crust, the White smoother, use of, 149
- crusts, various, for examination, 146
- roads described and illustrated, 144-149
- De Camp machine for, described and illustrated, 147, 148
- PATCHING** of stone roads, practice in, 125
- Patented materials, procedure in case of, 272
- Pavement, Belgian-block, see Belgian-block pavement,
- granite-block, see Granite-block pavement
- Pavements, asphalt, see Asphalt pavements
- brick, see Brick pavements
- cobblestone, see Cobblestone pavements
- stone, see Stone pavements
- various, comparison of loads carried on, 196
- effects of, on tractive force, illustrated, 10
- labor required to clean, illustrated, 197
- wood, see Wood pavements
- Payment for labor, materials, etc., New Jersey, 68
- Penfold on repairs to stone roads, 123
- Petroleum oil for asphaltic cement, requirements of, 249

- Pittsburg, street grades in, 167
Plan and system in city streets, with illustrations and formulas, 157-164
Plank roads, construction of, 152, 153
Plans and drawings for gravel roads, New Jersey practice, 56
Power required to draw a wheel over an obstacle, diagram, 4
Preserved woods, value of, in wood pavements, 282
- RAVELLING as factor in maintenance on stone roads, 119, 121, 122
Rectangular system of city streets, with illustration, 157, 158
Repair of earth roads, 44, 45
Repairs and maintenance of stone roads, 114-125
Resistance, grade, to estimate, with formulas, 16
 rolling, explained, 2
 to abrasion, stone roads, 91-94
Resistances, tractive, considered at length, 1 *et seq.*
Roads, burnt-clay, described, 143
 charcoal, construction of, 151, 152
 coal-slack, 151
 corduroy, described, 143, 144
 miscellaneous, described and illustrated, 143 *et seq.*
 oiling, described and illustrated, 144-149
 plank, construction of, 152, 153
 sand-clay, 154, 155
 shale, varieties and value, 150, 151
 slag, 150, 151
 stone, broken-stone, see Stone roads
Rock asphalts, laying, 252
 requirements of, when used, 251
Roller, steam, on finished stone road, illustrated, 87
Rollers, use of, on earth roads, 32
Rolling, brick pavements, 218
 in case of block asphalt pavement, 258
 stone roads, described and illustrated, 111, 112
 roads, New Jersey practice, 131
Rosewater and Herring, plan of intersection grades, 168
Ruts as factor in maintenance of stone roads, 118
 prevention of, by arrangement of axle-trees and wheels, 118, 119
- SAND for sheet asphalt pavement, 229, 242
Sand-clay roads, 154, 155
Sandstone for road-building, 105
Screening for gravel roads, 49
Shale in road-building, 105
 roads, varieties and value, 150, 151
Sheet asphalt pavement, see Asphalt pavement, sheet

- Shoulder in gravel roads, New Jersey practice, 58
- Side-hill streets, treatment of, 169
- Sidewalks for gravel roads, New Jersey practice, 60
New York City practice, 187
- Sieves and screens for stone cementation tests, 98, 99
- Size of broken stone for roads, 109, 110
- Slag roads, 150, 151
- Slope in gravel roads, New Jersey practice, 58
earth roads, with table, 43
- Specifications, New Jersey, for stone roads, 126-142
New York City, for block asphalt pavements, 254-272
New York City, for sheet asphalt pavement, 233-253
- Speed, relation of, to rolling resistance, 9
- Springs beneficial to road and vehicle, 9
- Stone breaker, for sheet asphalt pavement, 242, 243
placing on prepared subgrade, illustrated, 79
cementation tests, Washington practice, 101
dust for cementation test, preparing, 98
for sheet asphalt pavement, 229
for road, qualities required, opinions of Prof. A. Black, 81-91
roadmaking, qualities of, table, 103
roads, absorption test of Massachusetts Commission, 104
- French tests and coefficient of wear, 93
- laying, Massachusetts practice, 110
- pavements, 176 *et seq.*
bridgestones for, 243, 244
cement for, New York City practice, 191
fillers for joints, 182
foundation for, 181
foundation, New York City practice, 184
laying the stone, 182
New York City practice as to manholes, 184
removing old material, New York City practice, 184
- resistance to crushing, determination of, 102
- road, complete, illustrated, 89
subgrades being covered with broken stone, illustrated, 79
- roads, binder material, 112
bridges, etc., for, New Jersey requirements, 138
causes of repairing considered in detail, 115-122
cementation tests of material, 94-102
cross-section, 113
crown, amount of, 113
drainage, New Jersey requirements, 133, 137
forms of construction illustrated, 106, 107
kinds of rock commonly used, 104, 105

- Stone roads, lifting of, when and how it should be done, 124
longitudinal grade as factor in maintenance, 117
maintenance and repairs, Massachusetts practice, 114
modern, practice in, 73, 74
New Jersey practice in covering, 109
New Jersey specifications, 126-142
patching of, practice, 125
Penfold on repairs, 123
ravelling as factor in maintenance, 119, 121, 122
repairs and maintenance, 114-125
resistance to abrasion, tests, 91-94
ruts as factor in repairs, 118
size of broken stone, 109, 110
thickness of covering, 107-110
width of, Massachusetts practice, 112
width of, New Jersey practice, 112
tests, method of Prof. A. Black, 81-91
toughness tests, 102
- Street design, detailed study of, with illustrations, 156 *et seq.*
drainage, 169-172
grades, importance and treatment, 167
intersections, grades at, 168
- Streets, design, location, etc., with illustrations, 156 *et seq.*
diagonal system, Haupt on, with illustrations and formulas, 159-164
diagram of, in Washington, D. C., 163
gutters and curbs for, with illustrations, 169-172
location of, 156, 157
plan and system in, with illustrations and formulas, 157-164
rectangular system, with illustration, 157, 158
side-hill, treatment of, 169
treatment of crown, 172
trees as factor in design, 174, 175
width of carriageway, 165, 166
- Subfoundation of gravel roads, New Jersey practice, 58
- Subgrade of stone road being graded and rolled by machine, illustrated, 75,
77
- Subletting of contract, New Jersey, 67
- Subsurface drainage on earth roads, 32-38
- Surface, as factor in resistance and tractive force, 10
construction of gravel roads, 50, 51
- Surfaces, road, Missouri tests of various, 7-9
- Surfacing for stone roads, Massachusetts practice, 108, 109
- TELFORD foundation, laying, illustrated, 83
New Jersey practice, 129

- Telford pavement, description of, with illustrations, 71-74
 modern, 74
 road construction, illustrated, 85
- Temperature of paving cement, 246
 paving cement, New York City practice, 191
- Tests of road stone, method of Prof. A. Black, 81-91
- Tile drains, use of, on earth roads, with table of sizes, 35, 36
- Tillson on making of paving brick, 195, 196
- Tire, width of, effect on haulage and road preservation, 6-9
- Tires, broad, in New Jersey gravel road construction, 61
 in stone-road making, New Jersey practice, 134
- Toothing cement, 246
- Topography of city streets, 156, 157
- Toughness, tests of brick for paving, 198-200
 of stone, 102
- Trackway, in Murray Street, New York, 154
 in Chicago, 154
 the Albany and Schenectady, 154
- Trackways, abroad and in United States, 153, 154
 cost of, 153
 mode of construction, 153
- Traction tests, findings of various investigators, 10-19
- Tractive force, diagram and equations demonstrating, 3, 4
 effect of grade on, with table and illustrations, 21
- Tractograph, description of, 16
 in pavement tests, with illustration, 16
- Trap rock for roads, 104
- Trash or rubbish on stone roads as factor in maintenance, 120, 121
- Trees, consideration of, in street design, 174, 175
 on highway, Massachusetts experience, 175
 varieties planted, 175
- Trench construction of gravel roads, 52, 53
- Trenching stone road, illustrated, 106, 107
- UNDERDRAINS in gravel roads, New Jersey practice, 59
- WASHINGTON, D. C., diagram or arrangement of streets, 163
- Wear of stone, French tests and coefficient, 93
- Wearing surface for sheet asphalt pavement, 229-231
- Weather considerations in New Jersey specifications, 138
- Wheel, diameter of, as affecting rolling resistance, 5
- Wheels and axle-trees, arrangement of, to prevent ruts, 118, 119
- White smoother, the, for oiled crust, use of, 149
- Width of earth roads, right of way, etc., with illustrations, 42
 stone road, Massachusetts practice, 112

- Wood pavement, advantages and disadvantages, 274, 275
 - allowance for expansion in, 280, 281
 - chemical treatment of blocks, 278
 - filling for joints, 280
 - foundation for, 279
 - laying, 279-282
 - New York City requirements in block material, 292
 - New York City specifications for, 282-302
- pavements, causes of failure in, 281, 282
 - cement for, New York City requirements, 295
 - concrete for, New York City requirements, 296, 297
 - cutting closures in, 299
 - forms of blocks, 277, 278
 - grooved blocks, 299
 - method of laying, 298, 299
 - modern, history and description, 273 *et seq.*
 - treatment of grade in, 281
 - use of, in Europe, 273
 - value of preserved woods, 282
 - varieties and choice of woods, 276, 277
- Workmen, competency of, New Jersey, 66

SHORT-TITLE CATALOGUE

OF THE

PUBLICATIONS

OF

JOHN WILEY & SONS,

NEW YORK.

LONDON: CHAPMAN & HALL, LIMITED.

ARRANGED UNDER SUBJECTS.

Descriptive circulars sent on application. Books marked with an asterisk (*) are sold at *net* prices only. All books are bound in cloth unless otherwise stated.

AGRICULTURE—HORTICULTURE—FORESTRY.

Armsby's Principles of Animal Nutrition	8vo,	\$4 00
Budd and Hansen's American Horticultural Manual:		
Part I. Propagation, Culture, and Improvement.	12mo,	1 50
Part II. Systematic Pomology.	12mo,	1 50
Elliott's Engineering for Land Drainage.	12mo,	1 50
Practical Farm Drainage 2d Edition, Rewritten.	12mo,	1 50
Graves's Forest Mensuration.	8vo,	4 00
Green's Principles of American Forestry.	12mo,	1 50
Grotenfelt's Principles of Modern Dairy Practice. (Woll).	12mo,	2 00
* Herrick's Denatured or Industrial Alcohol.	8vo,	4 00
Kemp and Waugh's Landscape Gardening. New Edition, Rewritten. (In Preparation.)		
* McKay and Larsen's Principles and Practice of Butter-making	8vo,	1 50
Maynard's Landscape Gardening as Applied to Home Decoration.	12mo,	1 50
Quaintance and Scott's Insects and Diseases of Fruits. (In Preparation).		
Sanderson's Insects Injurious to Staple Crops.	12mo,	1 50
* Schwarz's Longleaf Pine in Virgin Forests.	12mo,	1 25
Stockbridge's Rocks and Soils.	8vo,	2 50
Winton's Microscopy of Vegetable Foods.	8vo,	7 50
Woll's Handbook for Farmers and Dairymen.	16mo,	1 50

ARCHITECTURE.

Baldwin's Steam Heating for Buildings.	12mo,	2 50
Berg's Buildings and Structures of American Railroads.	4to,	5 00
Birkmire's Architectural Iron and Steel.	8vo,	3 50
Compound Riveted Girders as Applied in Buildings.	8vo,	2 00
Planning and Construction of American Theatres.	8vo,	3 00
Planning and Construction of High Office Buildings.	8vo,	3 50
Skeleton Construction in Buildings.	8vo,	3 00
Briggs's Modern American School Buildings.	8vo,	4 00
Byrne's Inspection of Material and Workmanship Employed in Construction.	16mo,	3 00
Carpenter's Heating and Ventilating of Buildings.	8vo,	4 00
* Corthell's Allowable Pressure on Deep Foundations	12mo,	1 25

Freitag's Architectural Engineering.	8vo	3 50
Fireproofing of Steel Buildings.	8vo,	2 50
French and Ives's Stereotomy.	8vo,	2 50
Gerhard's Guide to Sanitary House-Inspection.	16mo,	1 00
* Modern Baths and Bath Houses.	8vo,	3 00
Sanitation of Public Buildings	12mo,	1 50
Theatre Fires and Panics.	12mo,	1 50
Holley and Ladd's Analysis of Mixed Paints, Color Pigments, and Varnishes	Large 12mo,	2 50
Johnson's Statics by Algebraic and Graphic Methods	8vo,	2 00
Kellaway's How to Lay Out Suburban Home Grounds	8vo,	2 00
Kidder's Architects' and Builders' Pocket-book.	16mo, mor.	5 00
Maire's Modern Pigments and their Vehicles	12mo,	2 00
Merrill's Non-metallic Minerals: Their Occurrence and Uses.	8vo,	4 00
Stones for Building and Decoration.	8vo,	5 00
Monckton's Stair-building.	4to,	4 00
Patton's Practical Treatise on Foundations.	8vo,	5 00
Peabody's Naval Architecture.	8vo,	7 50
Rice's Concrete-block Manufacture	8vo,	2 00
Richey's Handbook for Superintendents of Construction.	16mo, mor.	4 00
* Building Mechanics' Ready Reference Book:		
* Building Foreman's Pocket Book and Ready Reference. (In Preparation.)		
* Carpenters' and Woodworkers' Edition.	16mo, mor.	1 50
* Cement Workers and Plasterer's Edition.	16mo, mor.	1 50
* Plumbers', Steam-Filters', and Tanners' Edition.	16mo, mor.	1 50
* Stone- and Brick-masons' Edition.	16mo, mor.	1 50
Sabin's House Painting	12mo,	1 00
Industrial and Artistic Technology of Paints and Varnish.	8vo,	3 00
Siebert and Biggin's Modern Stone-cutting and Masonry.	8vo,	1 50
Snow's Principal Species of Wood.	8vo,	3 50
Towne's Locks and Builders' Hardware.	18mo, mor.	3 00
Wait's Engineering and Architectural Jurisprudence	8vo,	6 00
Law of Contracts.	Sheep,	6 50
Law of Operations Preliminary to Construction in Engineering and Architecture.	8vo,	3 00
Law of Operations Preliminary to Construction in Engineering and Architecture.	8vo,	5 00
Law of Operations Preliminary to Construction in Engineering and Architecture.	Sheep,	5 50
Wilson's Air Conditioning.	12mo,	1 50
Worcester and Atkinson's Small Hospitals, Establishment and Maintenance, Suggestions for Hospital Architecture, with Plans for a Small Hospital.	12mo,	1 25

ARMY AND NAVY.

Bernadou's Smokeless Powder, Nitro-cellulose, and the Theory of the Cellulose Molecule.	12mo,	2 50
Chase's Art of Pattern Making.	12mo,	2 50
Screw Propellers and Marine Propulsion.	8vo,	3 00
Cloke's Enlisted Specialist's Examiner. (In Press.)		
Gunner's Examiner	8vo,	1 50
Craig's Azimuth.	4to,	3 50
Crehore and Squier's Polarizing Photo-chronograph.	8vo,	3 00
* Davis's Elements of Law.	8vo,	2 50
* Treatise on the Military Law of United States.	8vo,	7 00
Treatise on the Military Law of United States.	Sheep,	7 50
De Brack's Cavalry Outpost Duties. (Carr).	24mo, mor.	2 00
* Dudley's Military Law and the Procedure of Courts-martial.	Large 12mo,	2 50
Durand's Resistance and Propulsion of Ships.	8vo,	5 00

* Dyer's Handbook of Light Artillery.	12mo,	
Elssler's Modern High Explosives.	8vo,	4 00
* Fiebeger's Text-book on Field Fortification.	Large 12mo,	2 00
Hamilton and Bond's The Gunner's Catechism	18mo,	1 00
* Hoff's Elementary Naval Tactics.	8vo,	1 50
Ingalls's Handbook of Problems in Direct Fire.	8vo,	4 00
* Lissak's Ordnance and Gunnery	8vo,	6 00
* Ludlow's Logarithmic and Trigonometric Tables	8vo,	1 00
* Lyons's Treatise on Electromagnetic Phenomena. Vols. I. and II..	8vo, each,	6 00
* Mahan's Permanent Fortifications. (Mercur)	8vo, half mor.	7 50
Manual for Courts-martial.	16mo, mor.	1 50
* Mercur's Attack of Fortified Places.	12mo,	2 00
* Elements of the Art of War.	8vo,	4 00
Metcalf's Cost of Manufactures—And the Administration of Workshops .	8vo,	5 00
Nixon's Adjutants' Manual.	24mo,	1 00
Peabody's Naval Architecture.	8vo,	7 50
* Phelps's Practical Marine Surveying.	8vo,	2 50
Putnam's Nautical Charts. (In Press.)		
Sharpe's Art of Subsisting Armies in War.	18mo, mor.	1 50
* Tupes and Poole's Manual of Bayonet Exercises and Musketry Fencing.	24mo, leather,	50
* Weaver's Military Explosives.	8vo,	3 00
Woodhull's Notes on Military Hygiene.	16mo,	1 50

ASSAYING.

Betts's Lead Refining by Electrolysis.	8vo,	4 00
Fletcher's Practical Instructions in Quantitative Assaying with the Blowpipe.	16mo, mor.	1 50
Furman's Manual of Practical Assaying.	8vo,	3 00
Lodge's Notes on Assaying and Metallurgical Laboratory Experiments, . . .	8vo,	3 00
Low's Technical Methods of Ore Analysis.	8vo,	3 00
Miller's Cyanide Process.	12mo,	1 00
Manual of Assaying.	12mo,	1 00
Minet's Production of Aluminum and its Industrial Use. (Waldo).. . . .	12mo,	2 50
O'Driscoll's Notes on the Treatment of Gold Ores.	8vo,	2 00
Ricketts and Miller's Notes on Assaying.	8vo,	3 00
Robine and Lenglen's Cyanide Industry. (Le Clerc).. . . .	8vo,	4 00
Ulke's Modern Electrolytic Copper Refining.	8vo,	3 00
Wilson's Chlorination Process.	12mo,	1 50
Cyanide Processes.	12mo,	1 50

ASTRONOMY.

Comstock's Field Astronomy for Engineers.	8vo,	2 50
Craig's Azimuth	4to,	3 50
Crandall's Text-book on Geodesy and Least Squares.	8vo,	3 00
Doolittle's Treatise on Practical Astronomy.	8vo,	4 00
Gore's Elements of Geodesy.	8vo,	2 50
Hayford's Text-book of Geodetic Astronomy.	8vo,	3 00
Merriman's Elements of Precise Surveying and Geodesy.	8vo,	2 50
* Michie and Harlow's Practical Astronomy.	8vo,	3 00
Rust's Ex-meridian Altitude, Azimuth and Star-Finding Tables. (In Press.)		
* White's Elements of Theoretical and Descriptive Astronomy	12mo,	2 00

CHEMISTRY.

* Abderhalden's Physiological Chemistry in Thirty Lectures. (Hall and Defren)	8vo, 5 00
* Abegg's Theory of Electrolytic Dissociation. (von Ende).....	12mo, 1 25
Alexeyeff's General Principles of Organic Syntheses. (Matthews).....	8vo, 3 00
Allen's Tables for Iron Analysis.	8vo, 3 00
Arnold's Compendium of Chemistry. (Mandel).....	Large 12mo, 3 50
Association of State and National Food and Dairy Departments, Hartford, Meeting, 1906	8vo, 3 00
Jamestown Meeting, 1907	8vo, 3 00
Austen's Notes for Chemical Students	12mo, 1 50
Baskerville's Chemical Elements. (In Preparation.)	
Bernadou's Smokeless Powder.—Nitro-cellulose, and Theory of the Cellulose Molecule	12mo, 2 50
* Blanchard's Synthetic Inorganic Chemistry.....	12mo, 1 00
* Browning's Introduction to the Rarer Elements.	8vo, 1 50
Brush and Penfield's Manual of Determinative Mineralogy.	8vo, 4 00
* Claassen's Beet-sugar Manufacture. (Hall and Rolfe).....	8vo, 3 00
Classen's Quantitative Chemical Analysis by Electrolysis. (Boltwood).....	8vo, 3 00
Cohn's Indicators and Test-papers.	12mo, 2 00
Tests and Reagents.	8vo, 3 00
* Danneel's Electrochemistry. (Merriam).....	12mo, 1 25
Duhem's Thermodynamics and Chemistry. (Burgess).....	8vo, 4 00
Eakle's Mineral Tables for the Determination of Minerals by their Physical Properties	8vo, 1 25
Eissler's Modern High Explosives.	8vo, 4 00
Effront's Enzymes and their Applications. (Prescott)	8vo, 3 00
Erdmann's Introduction to Chemical Preparations. (Dunlap).....	12mo, 1 25
* Fischer's Physiology of Alimentation	Large 12mo, 2 00
Fletcher's Practical Instructions in Quantitative Assaying with the Blowpipe.	12mo, mor. 1 50
Fowler's Sewage Works Analyses.....	12mo, 2 00
Fresenius's Manual of Qualitative Chemical Analysis. (Wells).....	8vo, 5 00
Manual of Qualitative Chemical Analysis. Part I. Descriptive. (Wells).....	8vo, 3 00
Quantitative Chemical Analysis. (Cohn) 2 vols.....	8vo, 12 50
When Sold Separately, Vol. I, \$6. Vol. II, \$8.	
Fuertes's Water and Public Health.	12mo, 1 50
Furman's Manual of Practical Assaying.	8vo, 3 00
* Getman's Exercises in Physical Chemistry.....	12mo, 2 00
Gill's Gas and Fuel Analysis for Engineers.	12mo, 1 25
* Gooch and Browning's Outlines of Qualitative Chemical Analysis.	Large 12mo, 1 25
Grotenfelt's Principles of Modern Dairy Practice. (Woll).....	12mo, 2 00
Groth's Introduction to Chemical Crystallography (Marshall)	12mo, 1 25
Hammarsten's Text-book of Physiological Chemistry. (Mandel).....	8vo, 4 00
Hanausek's Microscopy of Technical Products. Winton).....	8vo, 5 00
* Haskins and Macleod's Organic Chemistry	12mo, 2 00
Helm's Principles of Mathematical Chemistry. (Morgan).....	12mo, 1 50
Hering's Ready Reference Tables (Conversion Factors).....	16mo, mor. 2 50
* Herrick's Denatured or Industrial Alcohol	8vo, 4 00
Hinds's Inorganic Chemistry.	8vo, 3 00
* Laboratory Manual for Students	12mo, 1 00
* Holleman's Laboratory Manual of Organic Chemistry for Beginners. (Walker).....	12mo, 1 00
Text-book of Inorganic Chemistry. (Cooper).....	8vo, 2 50
Text-book of Organic Chemistry. (Walker and Mott).....	8vo, 2 50
Holley and Ladd's Analysis of Mixed Paints, Color Pigments, and Varnishes.	Large 12mo, 2 50

Hopkins's Oil-chemists' Handbook.....	8vo,	3 00
Iddings's Rock Minerals.....	8vo,	5 00
Jackson's Directions for Laboratory Work in Physiological Chemistry..	8vo,	1 25
Johannsen's Determination of Rock-forming Minerals in Thin Sections..	8vo,	4 00
Johnson's Chemical Analysis of Special Steels. (In Preparation.)		
Keep's Cast Iron.....	8vo,	2 50
Ladd's Manual of Quantitative Chemical Analysis.....	12mo,	1 00
Landauer's Spectrum Analysis. (Tingle).....	8vo,	3 00
* Langworthy and Austen's Occurrence of Aluminium in Vegetable Products, Animal Products, and Natural Waters.....	8vo,	2 00
Lassar-Cohn's Application of Some General Reactions to Investigations in Organic Chemistry. (Tingle).....	12mo,	1 00
Leach's Inspection and Analysis of Food with Special Reference to State Control.....	8vo,	7 50
Löb's Electrochemistry of Organic Compounds. (Lorenz).....	8vo,	3 00
Lodge's Notes on Assaying and Metallurgical Laboratory Experiments..	8vo,	3 00
Low's Technical Method of Ore Analysis.....	8vo,	3 00
Lunge's Techno-chemical Analysis. (Cohn).....	12mo,	1 00
* McKay and Larsen's Principles and Practice of Butter-making.....	8vo,	1 50
Maire's Modern Pigments and their Vehicles.....	12mo,	2 00
Mandel's Handbook for Bio-chemical Laboratory.....	12mo,	1 50
* Martin's Laboratory Guide to Qualitative Analysis with the Blowpipe..	12mo,	60
Mason's Examination of Water. (Chemical and Bacteriological).....	12mo,	1 25
Water-supply. (Considered Principally from a Sanitary Standpoint)	8vo,	4 00
Matthews's Textile Fibres. 2d Edition, Rewritten.....	8vo,	4 00
* Meyer's Determination of Radicles in Carbon Compounds. (Tingle)..	12mo,	1 25
Miller's Cyanide Process.....	12mo,	1 00
Manual of Assaying.....	12mo,	1 00
Minet's Production of Aluminum and its Industrial Use. (Waldo).....	12mo,	2 50
Mixer's Elementary Text-book of Chemistry.....	12mo,	1 50
Morgan's Elements of Physical Chemistry.....	12mo,	3 00
Outline of the Theory of Solutions and its Results.....	12mo,	1 00
* Physical Chemistry for Electrical Engineers.....	12mo,	1 50
Morse's Calculations used in Cane-sugar Factories.....	16mo, mor.	1 50
* Muir's History of Chemical Theories and Laws.....	8vo,	4 00
Mulliken's General Method for the Identification of Pure Organic Compounds.		
Vol. I.....	Large 8vo,	5 00
O'Driscoll's Notes on the Treatment of Gold Ores.....	8vo,	2 00
Ostwald's Conversations on Chemistry. Part One. (Ramsey).....	12mo,	1 50
" " " " Part Two. (Turnbull).....	12mo,	2 00
* Palmer's Practical Test Book of Chemistry.....	12mo,	1 00
* Pauli's Physical Chemistry in the Service of Medicine. (Fischer) ..	12mo,	1 25
* Penfield's Notes on Determinative Mineralogy and Record of Mineral Tests.	8vo, paper,	50
Tables of Minerals, Including the Use of Minerals and Statistics of Domestic Production.....	8vo,	1 00
Pictet's Alkaloids and their Chemical Constitution. (Biddle).....	8vo,	5 00
Poole's Calorific Power of Fuels.....	8vo,	3 00
Prescott and Winslow's Elements of Water Bacteriology, with Special Reference to Sanitary Water Analysis.....	12mo,	1 50
* Reising's Guide to Piece-dyeing.....	8vo,	25 00
Richards and Woodman's Air, Water, and Food from a Sanitary Standpoint..	8vo,	2 00
Ricketts and Miller's Notes on Assaying.....	8vo,	3 00
Rideal's Disinfection and the Preservation of Food.....	8vo,	4 00
Sewage and the Bacterial Purification of Sewage.....	8vo,	4 00
Riggs's Elementary Manual for the Chemical Laboratory.....	8vo,	1 25
Robine and Lenglen's Cyanide Industry. (Le Clerc).....	8vo,	4 00
Ruddiman's Incompatibilities in Prescriptions.....	8vo,	2 00
Whys in Pharmacy.....	12mo,	1 00

* Ives's Adjustments of the Engineer's Transit and Level	16mo, Bds.	25
Ives and Hilts's Problems in Surveying	16mo, mor.	1 50
Johnson's (J. B.) Theory and Practice of Surveying.	Small 8vo,	4 00
Johnson's (L. J.) Statics by Algebraic and Graphic Methods.	8vo,	2 00
Kinnicutt, Winslow and Pratt's Purification of Sewage. (In Preparation.)		
Laplace's Philosophical Essay on Probabilities. (Truscott and Emory)	12mo,	2 00
Mahan's Descriptive Geometry.	8vo,	1 50
Treatise on Civil Engineering. (1873.) (Wood).	8vo,	5 00
Merriman's Elements of Precise Surveying and Geodesy.	8vo,	2 50
Merriman and Brooks's Handbook for Surveyors.	16mo, mor.	2 00
Nugent's Plane Surveying.	8vo,	3 50
Ogden's Sewer Construction. (In Press.)		
Sewer Design	12mo,	2 00
Parsons's Disposal of Municipal Refuse.	8vo,	2 00
Patton's Treatise on Civil Engineering.	8vo, half leather,	7 50
Reed's Topographical Drawing and Sketching	4to,	5 00
Rideal's Sewage and the Bacterial Purification of Sewage.	8vo,	4 00
Riemer's Shaft-sinking under Difficult Conditions. (Corning and Peele).	8vo,	3 00
Siebert and Biggin's Modern Stone-cutting and Masonry.	8vo,	1 50
Smith's Manual of Topographical Drawing. (McMillan).	8vo,	2 50
Soper's Air and Ventilation of Subways	Large 12mo,	2 50
Tracy's Plane Surveying.	16mo, mor.	3 00
* Trautwine's Civil Engineer's Pocket-book.	16mo, mor.	5 00
Venable's Garbage Crematories in America.	8vo,	2 00
Methods and Devices for Bacterial Treatment of Sewage.	8vo,	3 00
Wait's Engineering and Architectural Jurisprudence.	8vo,	6 00
	Sheep,	6 50
Law of Contracts.	8vo,	3 00
Law of Operations Preliminary to Construction in Engineering and Architecture.	8vo,	5 00
	Sheep,	5 50
Warren's Stereotomy—Problems in Stone-cutting.	8vo,	2 50
* Waterbury's Vest-Pocket Hand-book of Mathematics for Engineers.		
	2 $\frac{1}{4}$ × 5 $\frac{1}{4}$ inches, mor.	1 00
Webb's Problems in the Use and Adjustment of Engineering Instruments.		
	16mo, mor.	1 25
Wilson's (H. N.) Topographic Surveying	8vo,	3 50
Wilson's (W. L.) Elements of Railroad Track and Construction. (In Press.)		

BRIDGES AND ROOFS.

Boller's Practical Treatise on the Construction of Iron Highway Bridges.	8vo,	2 00
Burr and Falk's Design and Construction of Metallic Bridges	8vo,	5 00
Influence Lines for Bridge and Roof Computations.	8vo,	3 00
Du Bois's Mechanics of Engineering. Vol. II.	Small 4to,	10 00
Foster's Treatise on Wooden Trestle Bridges.	4to,	5 00
Fowler's Ordinary Foundations	8vo,	3 50
French and Ives's Stereotomy.	8vo,	2 50
Greene's Arches in Wood, Iron, and Stone.	8vo,	2 50
Bridge Trusses.	8vo,	2 50
Roof Trusses.	8vo,	1 25
Grimm's Secondary Stresses in Bridge Trusses.	8vo,	2 50
Heller's Stresses in Structures and the Accompanying Deformations.	8vo,	3 00
Howe's Design of Simple Roof-trusses in Wood and Steel.	8vo,	2 00
Symmetrical Masonry Arches.	8vo,	2 50
Treatise on Arches.	8vo,	4 00
Johnson, Bryan, and Turneure's Theory and Practice in the Designing of Modern Framed Structures.	Small 4to,	10 00

Merriman and Jacoby's Text-book on Roofs and Bridges:	
Part I. Stresses in Simple Trusses.....	8vo, 2 50
Part II. Graphic Statics.....	8vo, 2 50
Part III. Bridge Design.....	8vo, 2 50
Part IV. Higher Structures.....	8vo, 2 50
Morison's Memphis Bridge.....	Oblong 4to, 10 00
Sondericker's Graphic Statics, with Applications to Trusses, Beams, and Arches.	8vo, 2 00
Waddell's De Pontibus, Pocket-book for Bridge Engineers.....	16mo, mor, 2 00
* Specifications for Steel Bridges.....	12mo, 50
Waddell and Harrington's Bridge Engineering. (In Preparation.)	
Wright's Designing of Draw-spans. Two parts in one volume.....	8vo. 3 50

HYDRAULICS.

Barnes's Ice Formation.....	8vo, 3 00
Bazin's Experiments upon the Contraction of the Liquid Vein Issuing from an Orifice. (Trautwine).....	8vo, 2 00
Bovey's Treatise on Hydraulics.....	8vo, 5 00
Church's Diagrams of Mean Velocity of Water in Open Channels.	Oblong 4to, paper, 1 50
Hydraulic Motors.....	8vo, 2 00
Mechanics of Engineering.....	8vo, 6 00
Coffin's Graphical Solution of Hydraulic Problems.....	16mo, mor. 2 50
Flather's Dynamometers, and the Measurement of Power.....	12mo, 3 00
Folwell's Water-supply Engineering.....	8vo, 4 00
Frizell's Water-power.....	8vo, 5 00
Fuertes's Water and Public Health.....	12mo, 1 50
Water-filtration Works.....	12mo, 2 50
Ganguillet and Kutter's General Formula for the Uniform Flow of Water in Rivers and Other Channels. (Hering and Trautwine).....	8vo, 4 00
Hazen's Clean Water and How to Get It.....	Large 12mo, 1 50
Filtration of Public Water-supplies.....	8vo, 3 00
Hazlehurst's Towers and Tanks for Water-works.....	8vo, 2 50
Herschel's 115 Experiments on the Carrying Capacity of Large, Riveted, Metal Conduits.....	8vo, 2 00
Hoyt and Grover's River Discharge.....	8vo, 2 00
Hubbard and Kiersted's Water-works Management and Maintenance.....	8vo, 4 00
* Lyndon's Development and Electrical Distribution of Water Power.....	8vo, 3 00
Mason's Water-supply. (Considered Principally from a Sanitary Standpoint.)	8vo, 4 00
Merriman's Treatise on Hydraulics.....	8vo, 5 00
* Michie's Elements of Analytical Mechanics.....	8vo, 4 00
* Molitor's Hydraulics of Rivers, Weirs and Sluices.....	8vo, 2 00
Schuyler's Reservoirs for Irrigation, Water-power, and Domestic Water-supply.....	Large 8vo, 5 00
* Thomas and Watt's Improvement of Rivers.....	4to, 6 00
Turneure and Russell's Public Water-supplies.....	8vo, 5 00
Wegmann's Design and Construction of Dams. 5th Ed., enlarged.....	4to, 6 00
Water-supply of the City of New York from 1658 to 1895.....	4to, 10 00
Whipple's Value of Pure Water.....	Large 12mo, 1 00
Williams and Hazen's Hydraulic Tables.....	8vo, 1 50
Wilson's Irrigation Engineering.....	Small 8vo, 4 00
Wolff's Windmill as a Prime Mover.....	8vo, 3 00
Wood's Elements of Analytical Mechanics.....	8vo, 3 00
Turbines.....	8vo, 2 50

MATERIALS OF ENGINEERING.

Baker's Roads and Pavements.	8vo, 5 00
Treatise on Masonry Construction.	8vo, 5 00
Birkmire's Architectural Iron and Steel.	8vo, 3 50
Compound Riveted Girders as Applied in Buildings.	8vo, 2 00
Black's United States Public Works	Oblong 4to, 5 00
Bleininger's Manufacture of Hydraulic Cement. (In Preparation.)	
* Bovey's Strength of Materials and Theory of Structures.	8vo, 7 50
Burr's Elasticity and Resistance of the Materials of Engineering.	8vo, 7 50
Byrne's Highway Construction.	8vo, 5 00
Inspection of the Materials and Workmanship Employed in Construction.	16mo, 3 00
Church's Mechanics of Engineering.	8vo, 6 00
Du Bois's Mechanics of Engineering.	
Vol. I. Kinematics, Statics, Kinetics.	Small 4to, 7 50
Vol. II. The Stresses in Framed Structures, Strength of Materials and Theory of Flexures.	Small 4to, 10 00
*Eckel's Cements, Limes, and Plasters.	8vo, 6 00
Stone and Clay Products used in Engineering. (In Preparation.)	
Fowler's Ordinary Foundations.	8vo, 3 50
Graves's Forest Mensuration.	8vo, 4 00
Green's Principles of American Forestry.	12mo, 1 50
* Greene's Structural Mechanics.	8vo, 2 50
Holly and Ladd's Analysis of Mixed Paints, Color Pigments and Varnishes	Large 12mo, 2 50
Johnson's (C. M.) Chemical Analysis of Special Steels. (In Preparation.)	
Johnson's (J. B.) Materials of Construction	Large 8vo, 6 00
Keep's Cast Iron.	8vo, 2 50
Kidder's Architects and Builders' Pocket-book.	16mo, 5 00
Lanza's Applied Mechanics.	8vo, 7 50
Maire's Modern Pigments and their Vehicles	12mo, 2 00
Martens's Handbook on Testing Materials. (Henning) 2 vols.	8vo, 7 50
Maurer's Technical Mechanics.	8vo, 4 00
Merrill's Stones for Building and Decoration.	8vo, 5 00
Merriman's Mechanics of Materials.	8vo, 5 00
* Strength of Materials	12mo, 1 00
Metcalf's Steel. A Manual for Steel-users.	12mo, 2 00
Morrison's Highway Engineering	8vo, 2 50
Patton's Practical Treatise on Foundations.	8vo, 5 00
Rice's Concrete Block Manufacture	8vo, 2 00
Richardson's Modern Asphalt Pavements.	8vo, 2 00
Richey's Handbook for Superintendents of Construction.	16mo, mor. 4 00
* Ries's Clays: Their Occurrence, Properties, and Uses.	8vo, 5 00
Sabin's Industrial and Artistic Technology of Paints and Varnish.	8vo, 3 00
* Schwarz's Longleaf Pine in Virgin Forest	12mo, 1 25
Snow's Principal Species of Wood.	8vo, 3 50
Spalding's Hydraulic Cement.	12mo, 2 00
Text-book on Roads and Pavements.	12mo, 2 00
Taylor and Thompson's Treatise on Concrete, Plain and Reinforced.	8vo, 5 00
Thurston's Materials of Engineering. In Three Parts.	8vo, 8 00
Part I. Non-metallic Materials of Engineering and Metallurgy.	8vo, 2 00
Part II. Iron and Steel.	8vo, 3 50
Part III. A Treatise on Brasses, Bronzes, and Other Alloys and their Constituents.	8vo, 2 50
Tillson's Street Pavements and Paving Materials.	8vo, 4 00
Turneure and Maurer's Principles of Reinforced Concrete Construction.	8vo, 3 00
Waterbury's Manual of Instructions for the Use of Students in Cement Labora- tory Practice. (In Press.)	

Wood's (De V.) Treatise on the Resistance of Materials, and an Appendix on the Preservation of Timber.	8vo,	2 00
Wood's (M. P.) Rustless Coatings: Corrosion and Electrolysis of Iron and Steel.	8vo,	4 00

RAILWAY ENGINEERING.

Andrews's Handbook for Street Railway Engineers	3x5 inches, mor.	1 25
Berg's Buildings and Structures of American Railroads	4to,	5 00
Brooks's Handbook of Street Railroad Location.	16mo, mor.	1 50
Batt's Civil Engineer's Field-book.	16mo, mor.	2 50
Crandall's Railway and Other Earthwork Tables.	8vo,	1 50
Transition Curve.	16mo, mor.	1 50
* Crockett's Methods for Earthwork Computations.	8vo,	1 50
Dawson's "Engineering" and Electric Traction Pocket-book.	16mo, mor.	5 00
Dredge's History of the Pennsylvania Railroad: (1879).	Paper,	5 00
Fisher's Table of Cubic Yards.	Cardboard,	25
Godwin's Railroad Engineers' Field-book and Explorers' Guide.	16mo, mor.	2 50
Hudson's Tables for Calculating the Cubic Contents of Excavations and Embankments.	8vo,	1 00
Ives and Hilts's Problems in Surveying, Railroad Surveying and Geodesy	16mo, mor.	1 50
Molitor and Beard's Manual for Resident Engineers.	16mo,	1 00
Nagle's Field Manual for Railroad Engineers.	16mo, mor.	3 00
Philbrick's Field Manual for Engineers.	16mo, mor.	3 00
Raymond's Railroad Engineering. 3 volumes.		
Vol. I. Railroad Field Geometry. (In Preparation.)		
Vol. II. Elements of Railroad Engineering.	8vo,	3 50
Vol. III. Railroad Engineer's Field Book. (In Preparation.)		
Searles's Field Engineering.	16mo, mor.	3 00
Railroad Spiral.	16mo, mor.	1 50
Taylor's Prismoidal Formulæ and Earthwork.	8vo,	1 50
* Trautwine's Field Practice of Laying Out Circular Curves for Railroads.	12mo, mor.	2 50
* Method of Calculating the Cubic Contents of Excavations and Embankments by the Aid of Diagrams.	8vo,	2 00
Webb's Economics of Railroad Construction.	Large 12mo,	2 50
Railroad Construction.	16mo, mor.	5 00
Wellington's Economic Theory of the Location of Railways.	Small 8vo,	5 00

DRAWING.

Barr's Kinematics of Machinery.	8vo,	2 50
* Bartlett's Mechanical Drawing.	8vo,	3 00
* " " " " Abridged Ed.	8vo,	1 50
Coolidge's Manual of Drawing.	8vo, paper,	1 00
Coolidge and Freeman's Elements of General Drafting for Mechanical Engineers.	Oblong 4to,	2 50
Durley's Kinematics of Machines.	8vo,	4 00
Emch's Introduction to Projective Geometry and its Applications.	8vo,	2 50
Hill's Text-book on Shades and Shadows, and Perspective.	8vo,	2 00
Jamison's Advanced Mechanical Drawing.	8vo,	2 00
Elements of Mechanical Drawing.	8vo,	2 50
Jones's Machine Design:		
Part I. Kinematics of Machinery.	8vo,	1 50
Part II. Form, Strength, and Proportions of Parts.	8vo,	3 00
MacCord's Elements of Descriptive Geometry.	8vo,	3 00
Kinematics; or, Practical Mechanism.	8vo,	5 00
Mechanical Drawing.	4to,	4 00
Velocity Diagrams.	8vo,	1 50

McLeod's Descriptive Geometry.....	Large 12mo,	1 50
* Mahan's Descriptive Geometry and Stone-cutting.....	8vo,	1 50
Industrial Drawing. (Thompson).....	8vo,	3 50
Moyer's Descriptive Geometry.....	8vo,	2 00
Reed's Topographical Drawing and Sketching.....	4to,	5 00
Reid's Course in Mechanical Drawing.....	8vo,	2 00
Text-book of Mechanical Drawing and Elementary Machine Design.....	8vo,	3 00
Robinson's Principles of Mechanism.....	8vo,	3 00
Schwamb and Merrill's Elements of Mechanism.....	8vo,	3 00
Smith's (R. S.) Manual of Topographical Drawing. (McMillan).....	8vo,	2 50
Smith (A. W.) and Marx's Machine Design.....	8vo,	3 00
* Titsworth's Elements of Mechanical Drawing.....	Oblong 8vo,	1 25
Warren's Drafting Instruments and Operations.....	12mo,	1 25
Elements of Descriptive Geometry, Shadows, and Perspective.....	8vo,	3 50
Elements of Machine Construction and Drawing.....	8vo,	7 50
Elements of Plane and Solid Free-hand Geometrical Drawing.....	12mo,	1 00
General Problems of Shades and Shadows.....	8vo,	3 00
Manual of Elementary Problems in the Linear Perspective of Form and Shadow.....	12mo,	1 00
Manual of Elementary Projection Drawing.....	12mo,	1 50
Plane Problems in Elementary Geometry.....	12mo,	1 25
Problems, Theorems, and Examples in Descriptive Geometry.....	8vo,	2 50
Weisbach's Kinematics and Power of Transmission. (Hermann and Klein).....	8vo,	5 00
Wilson's (H. M.) Topographic Surveying.....	8vo,	3 50
Wilson's (V. T.) Free-hand Lettering.....	8vo,	1 00
Free-hand Perspective.....	8vo,	2 50
Woolf's Elementary Course in Descriptive Geometry.....	Large 8vo,	3 00

ELECTRICITY AND PHYSICS.

* Abegg's Theory of Electrolytic Dissociation. (von Ende).....	12mo,	1 25
Andrews's Hand-Book for Street Railway Engineering.....	3 X 5 inches, mor.	1 25
Anthony and Brackett's Text-book of Physics. (Magie).....	Large 12mo,	3 00
Anthony's Lecture-notes on the Theory of Electrical Measurements.....	12mo,	1 00
Benjamin's History of Electricity.....	8vo,	3 00
Voltaic Cell.....	8vo,	3 00
Betts's Lead Refining and Electrolysis.....	8vo,	4 00
Classen's Quantitative Chemical Analysis by Electrolysis. (Boltwood).....	8vo,	3 00
* Collins's Manual of Wireless Telegraphy.....	12mo,	1 50
Mor.....		2 00
Crehore and Squier's Polarizing Photo-chronograph.....	8vo,	3 00
* Danneel's Electrochemistry. (Merriam).....	12mo,	1 25
Dawson's "Engineering" and Electric Traction Pocket-book.....	16mo, mor.	5 00
Dolezalek's Theory of the Lead Accumulator (Storage Battery). (von Ende).....	12mo,	2 50
Duhem's Thermodynamics and Chemistry. (Burgess).....	8vo,	4 00
Flather's Dynamometers, and the Measurement of Power.....	12mo,	3 00
Gilbert's De Magnete. (Mottelay).....	8vo,	2 50
* Hanchett's Alternating Currents.....	12mo,	1 00
Hering's Ready Reference Tables (Conversion Factors).....	16mo, mor.	2 50
* Hobart and Ellis's High-speed Dynamo Electric Machinery.....	8vo,	6 00
Holman's Precision of Measurements.....	8vo,	2 00
Telescopic Mirror-scale Method, Adjustments, and Tests.....	Large 8vo,	75
* Karapetoff's Experimental Electrical Engineering.....	8vo,	6 00
Kinzbrunner's Testing of Continuous-current Machines.....	8vo,	2 00
Landauer's Spectrum Analysis. (Tingle).....	8vo,	3 00
Le Chatelier's High-temperature Measurements. (Boudouard—Burgess).....	12mo,	3 00
Löb's Electrochemistry of Organic Compounds. (Lorenz).....	8vo,	3 00
* London's Development and Electrical Distribution of Water Power.....	8vo,	3 00

* Lyons's Treatise on Electromagnetic Phenomena. Vols. I. and II. 8vo, each,	6 00
* Michie's Elements of Wave Motion Relating to Sound and Light.	8vo, 4 00
Morgan's Outline of the Theory of Solution and its Results.	12mo, 1 00
* Physical Chemistry for Electrical Engineers.	12mo, 1 50
Niaudet's Elementary Treatise on Electric Batteries. (Fishback).	12mo, 2 50
* Norris's Introduction to the Study of Electrical Engineering.	8vo, 2 50
* Parshall and Hobart's Electric Machine Design.	4to, half mor. 12 50
Reagan's Locomotives: Simple, Compound, and Electric. New Edition.	
	Large 12mo, 3 50
* Rosenberg's Electrical Engineering. (Haldane Gee—Kinzbrunner).	8vo, 2 00
Ryan, Norris, and Hoxie's Electrical Machinery. Vol. I.	8vo, 2 50
Schapper's Laboratory Guide for Students in Physical Chemistry	12mo, 1 00
* Tillman's Elementary Lessons in Heat.	8vo, 1 50
Tory and Pitcher's Manual of Laboratory Physics.	Large 12mo, 2 00
Ulke's Modern Electrolytic Copper Refining.	8vo, 3 00

LAW.

* Davis's Elements of Law.	8vo, 2 50
* Treatise on the Military Law of United States.	8vo, 7 00
*	Sheep, 7 50
* Dudley's Military Law and the Procedure of Courts-martial	Large 12mo, 2 50
Manual for Courts-martial.	16mo, mor. 1 50
Wait's Engineering and Architectural Jurisprudence.	8vo, 6 00
	Sheep, 6 50
Law of Contracts.	8vo, 3 00
Law of Operations Preliminary to Construction in Engineering and Archi- tecture.	8vo, 5 00
	Sheep, 5 50

MATHEMATICS.

Baker's Elliptic Functions	8vo, 1 50
Briggs's Elements of Plane Analytic Geometry. (Böcher).	12mo, 1 00
* Buchanan's Plane and Spherical Trigonometry.	8vo, 1 00
Byerley's Harmonic Functions.	8vo, 1 00
Chandler's Elements of the Infinitesimal Calculus.	12mo, 2 00
Compton's Manual of Logarithmic Computations	12mo, 1 50
* Dickson's College Algebra	Large 12mo, 1 50
* Introduction to the Theory of Algebraic Equations	Large 12mo, 1 25
Emch's Introduction to Projective Geometry and its Applications	8vo, 2 50
Fiske's Functions of a Complex Variable.	8vo, 1 00
Halsted's Elementary Synthetic Geometry	8vo, 1 50
Elements of Geometry	8vo, 1 75
* Rational Geometry	12mo, 1 50
Hyde's Grassmann's Space Analysis.	8vo, 1 00
* Jonnson's (J. B.) Three-place Logarithmic Tables: Vest-pocket size, paper,	15
	100 copies, 5 00
*	Mounted on heavy cardboard, 8×10 inches,
	10 copies, 2 00
Johnson's (W. W.) Abridged Editions of Differential and Integral Calculus	
	Large 12mo, 1 vol. 2 50
Curve Tracing in Cartesian Co-ordinates	12mo, 1 00
Differential Equations.	8vo, 1 00
Elementary Treatise on Differential Calculus	Large 12mo, 1 50
Elementary Treatise on the Integral Calculus	Large 12mo, 1 50
* Theoretical Mechanics.	12mo, 3 00
Theory of Errors and the Method of Least Squares.	12mo, 1 50
Treatise on Differential Calculus.	Large 12mo, 3 00
Treatise on the Integral Calculus.	Large 12mo, 3 00
Treatise on Ordinary and Partial Differential Equations.	Large 12mo, 3 50

Laplace's Philosophical Essay on Probabilities. (Truscott and Emory)..	12mo,	2 00
* Ludlow and Bass's Elements of Trigonometry and Logarithmic and Other Tables	8vo,	3 00
Trigonometry and Tables published separately	Each,	2 00
* Ludlow's Logarithmic and Trigonometric Tables	8vo,	1 00
Macfarlane's Vector Analysis and Quaternions.....	8vo,	1 00
McMahon's Hyperbolic Functions.....	8vo,	1 00
Manning's Irrational Numbers and their Representation by Sequences and Series	12mo,	1 25
Mathematical Monographs. Edited by Mansfield Merriman and Robert S. Woodward.	Octavo, each	1 00
No. 1. History of Modern Mathematics, by David Eugene Smith.		
No. 2. Synthetic Projective Geometry, by George Bruce Halsted.		
No. 3. Determinants, by Laenas Gifford Weld. No. 4. Hyper- bolic Functions, by James McMahon. No. 5. Harmonic Func- tions, by William E. Byerly. No. 6. Grassmann's Space Analysis, by Edward W. Hyde. No. 7. Probability and Theory of Errors, by Robert S. Woodward. No. 8. Vector Analysis and Quaternions, by Alexander Macfarlane. No. 9. Differential Equations, by William Woolsey Johnson. No. 10. The Solution of Equations, by Mansfield Merriman. No. 11. Functions of a Complex Variable, by Thomas S. Fiske.		
Maurer's Technical Mechanics.	8vo,	4 00
Merriman's Method of Least Squares.....	8vo,	2 00
Solution of Equations	8vo,	1 00
Rice and Johnson's Differential and Integral Calculus. 2 vols. in one.		
	Large 12mo,	1 50
Elementary Treatise on the Differential Calculus.....	Large 12mo,	3 00
Smith's History of Modern Mathematics	8vo,	1 00
* Veblen and Lennes's Introduction to the Real Infinitesimal Analysis of One Variable.....	8vo,	2 00
* Waterbury's Vest Pocket Hand-Book of Mathematics for Engineers.		
	2 $\frac{1}{8}$ × 5 $\frac{1}{8}$ inches, mor.	1 00
Weld's Determinations.....	8vo,	1 00
Wood's Elements of Co-ordinate Geometry.	8vo,	2 00
Woodward's Probability and Theory of Errors.....	8vo,	1 00

MECHANICAL ENGINEERING.

MATERIALS OF ENGINEERING, STEAM-ENGINES AND BOILERS.

Bacon's Forge Practice.	12mo,	1 50
Baldwin's Steam Heating for Buildings.	12mo,	2 50
Barr's Kinematics of Machinery.	8vo,	2 50
* Bartlett's Mechanical Drawing.....	8vo,	3 00
* " " " " Abridged Ed.	8vo,	1 50
Benjamin's Wrinkles and Recipes.....	12mo,	2 00
* Burr's Ancient and Modern Engineering and the Isthmian Canal.....	8vo,	3 50
Carpenter's Experimental Engineering.	8vo,	6 00
Heating and Ventilating Buildings.....	8vo,	4 00
Clerk's Gas and Oil Engine.....	Large 12mo,	4 00
Compton's First Lessons in Metal Working	12mo,	1 50
Compton and De Groodt's Speed Lathe.....	12mo,	1 50
Coolidge's Manual of Drawing.	8vo, paper,	1 00
Coolidge and Freeman's Elements of General Drafting for Mechanical En- gineers.....	Oblong 4to,	2 50
Cromwell's Treatise on Belts and Pulleys.....	12mo,	1 50
Treatise on Toothed Gearing.	12mo,	1 50
Durley's Kinematics of Machines.	8vo,	4 00

* Iddings's Rock Minerals	8vo,	5 00
Johannsen's Determination of Rock-forming Minerals in Thin Sections	8vo,	4 00
* Martin's Laboratory Guide to Qualitative Analysis with the Blowpipe	12mo,	60
Merrill's Non-metallic Minerals: Their Occurrence and Uses	8vo,	4 00
Stones for Building and Decoration	8vo,	5 00
* Penfield's Notes on Determinative Mineralogy and Record of Mineral Tests	8vo, paper,	50
Tables of Minerals, Including the Use of Minerals and Statistics of Domestic Production	8vo,	1 00
* Pirsson's Rocks and Rock Minerals	12mo,	2 50
* Richards's Synopsis of Mineral Characters	12mo, mor.	1 25
* Ries's Clays: Their Occurrence, Properties, and Uses	8vo,	5 00
* Tillman's Text-book of Important Minerals and Rocks	8vo,	2 00

MINING.

* Beard's Mine Gases and Explosions	Large 12mo,	3 00
Boyd's Map of Southwest Virginia	Pocket-book form	2 00
Resources of Southwest Virginia	8vo,	3 00
* Crane's Gold and Silver	8vo,	5 00
Douglas's Untechnical Addresses on Technical Subjects	12mo	1 30
Eissler's Modern High Explosives	8vo,	4 00
Goesel's Minerals and Metals: A Reference Book	16mo, mor.	3 00
Ihlseng's Manual of Mining	8vo,	5 00
* Iles's Lead-smelting	12mo,	2 50
Miller's Cyanide Process	12mo,	1 00
O'Driscoll's Notes on the Treatment of Gold Ores	8vo,	2 00
Peele's Compressed Air Plant for Mines	8vo,	3 00
Riemer's Shaft Sinking Under Difficult Conditions. (Corning and Peele)	8vo,	3 00
Robine and Lenglen's Cyanide Industry. (Le Clerc)	8vo,	4 00
* Weaver's Military Explosives	8vo,	3 00
Wilson's Chlorination Process	12mo,	1 50
Cyanide Processes	12mo,	1 50
Hydraulic and Placer Mining. 2d edition, rewritten	12mo,	2 50
Treatise on Practical and Theoretical Mine Ventilation	12mo,	1 25

SANITARY SCIENCE.

Association of State and National Food and Dairy Departments, Hartford Meeting, 1906	8vo,	3 00
Jamestown Meeting, 1907	8vo,	3 00
* Bashore's Outlines of Practical Sanitation	12mo,	1 25
Sanitation of a Country House	12mo,	1 00
Sanitation of Recreation Camps and Parks	12mo,	1 00
Folwell's Sewerage. (Designing, Construction, and Maintenance)	8vo,	3 00
Water-supply Engineering	8vo,	4 00
Fowler's Sewage Works Analyses	12mo,	2 00
Fuertes's Water-filtration Works	12mo,	2 50
Water and Public Health	12mo,	1 50
Gerhard's Guide to Sanitary House-inspection	16mo,	1 00
* Modern Baths and Bath Houses	8vo,	3 00
Sanitation of Public Buildings	12mo,	1 50
Hazen's Clean Water and How to Get It	Large 12mo,	1 50
Filtration of Public Water-supplies	8vo,	3 00
Kinnicut, Winslow and Pratt's Purification of Sewage. (In Press.)		
Leach's Inspection and Analysis of Food with Special Reference to State Control	8vo,	7 00
Mason's Examination of Water. (Chemical and Bacteriological)	12mo,	1 25
Water-supply. (Considered Principally from a Sanitary Standpoint)	8vo,	4 00

* Merriman's Elements of Sanitary Engineering	8vo,	2 00
Ogden's Sewer Design.	12mo,	2 00
Parsons's Disposal of Municipal Refuse.	8vo,	2 00
Prescott and Winslow's Elements of Water Bacteriology, with Special Reference to Sanitary Water Analysis.	12mo,	1 50
* Price's Handbook on Sanitation.	12mo,	1 50
Richards's Cost of Food. A Study in Dietaries.	12mo,	1 00
Cost of Living as Modified by Sanitary Science.	12mo,	1 00
Cost of Shelter.	12mo,	1 00
* Richards and Williams's Dietary Computer.	8vo,	1 50
Richards and Woodman's Air, Water, and Food from a Sanitary Standpoint.	8vo,	2 00
Rideal's Disinfection and the Preservation of Food.	8vo,	4 00
Sewage and Bacterial Purification of Sewage.	8vo,	4 00
Soper's Air and Ventilation of Subways.	Large 12mo,	2 50
Turneure and Russell's Public Water-supplies.	8vo,	5 00
Venable's Garbage Crematories in America.	8vo,	2 00
Method and Devices for Bacterial Treatment of Sewage.	8vo,	3 00
Ward and Whipple's Freshwater Biology. (In Press.)		
Whipple's Microscopy of Drinking-water.	8vo,	3 50
* Typhoid Fever.	Large 12mo,	3 00
Value of Pure Water.	Large 12mo,	1 00
Winslow's Bacterial Classification. (In Press.)		
Winton's Microscopy of Vegetable Foods.	8vo,	7 50

MISCELLANEOUS.

Emmons's Geological Guide-book of the Rocky Mountain Excursion of the International Congress of Geologists.	Large 8vo,	1 50
Ferrel's Popular Treatise on the Winds.	8vo,	4 00
Fitzgerald's Boston Machinist.	18mo,	1 00
Gannett's Statistical Abstract of the World.	24mo,	75
Haines's American Railway Management.	12mo,	2 50
* Hanusek's The Microscopy of Technical Products. (Winton).	8vo,	5 00
Ricketts's History of Rensselaer Polytechnic Institute 1824-1894.	Large 12mo,	3 00
Rotherham's Emphasized New Testament.	Large 8vo,	2 00
Standage's Decoration of Wood, Glass, Metal, etc.	12mo,	2 00
Thome's Structural and Physiological Botany. (Bennett).	16mo,	2 25
Westermaier's Compendium of General Botany. (Schneider).	8vo,	2 00
Winslow's Elements of Applied Microscopy.	12mo,	1 50

HEBREW AND CHALDEE TEXT-BOOKS.

Green's Elementary Hebrew Grammar.	12mo,	1 25
Gesenius's Hebrew and Chaldee Lexicon to the Old Testament Scriptures. (Tregelles).	Small 4to, half mor.	5 00

STATE LIBRARY OF IOWA



3 1723 02116 9362