

TE  
228  
F956  
1991a

LIB  
807.3

**FULL-SCALE 5,400 LB. VEHICLE CRASH TEST  
ON THE  
IOWA W-BEAM APPROACH GUARDRAIL  
TO THE  
CONCRETE SAFETY SHAPE BRIDGE RAIL**

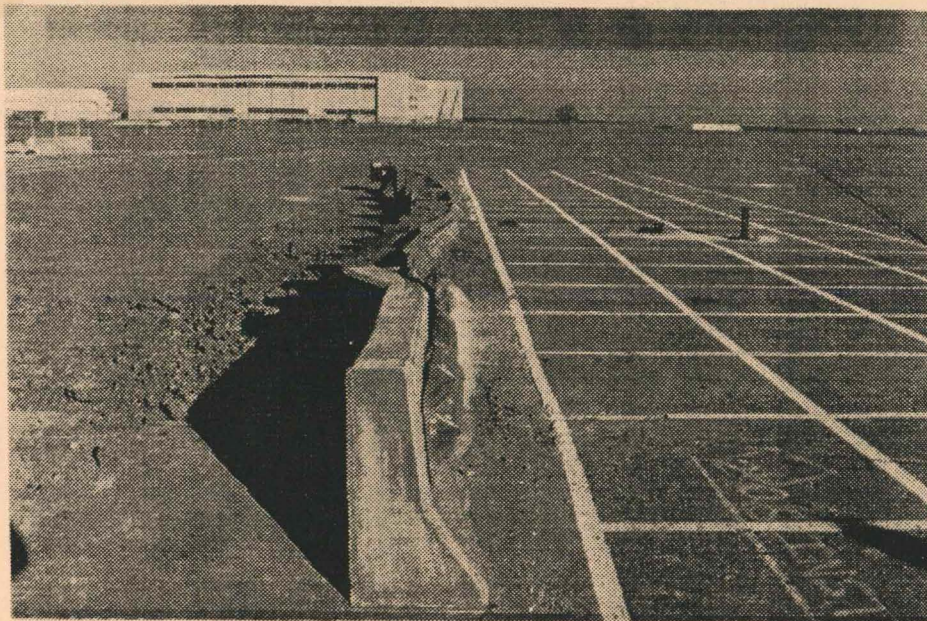

by

Mr. Ronald K. Faller, E.I.T.  
Research Associate Engineer

Mr. Syed Atallah  
Assistant Research Engineer

Mr. Brian G. Pfeifer, E.I.T.  
Assistant Research Engineer

Mr. James C. Holloway  
Assistant Research Engineer

Dr. Edward R. Post, P.E.  
Professor of Civil Engineering

submitted to

Mr. William A. Lundquist, P.E.  
Bridge Engineer  
Iowa Department of Transportation

in cooperation with

Federal Highway Administration - Iowa Division

TRANSPORTATION RESEARCH REPORT TRP-03-21-90

Civil Engineering Department  
W 348 Nebraska Hall  
University of Nebraska-Lincoln  
Lincoln, Nebraska 68588-0531

IOWA DEPT. OF TRANSPORTATION  
LIBRARY  
800 LINCOLN WAY  
AMES, IOWA 50010

January 1990

## **DISCLAIMER STATEMENT**

The contents of this report reflect the views of the authors who are responsible for the facts and accuracy of the data presented herein. The contents do not necessarily reflect the official views or policies of the Iowa Department of Transportation or the Federal Highway Administration. This report does not constitute a standard, specification or regulation.

---

## ABSTRACT

One full-scale vehicle crash test was conducted on the Iowa W-Beam Approach Guardrail Transition Section to the Concrete Safety Shape Bridge Rail. Test I6-1 was conducted with a 5,420 lb. vehicle at 20.0 degrees and 61.45 mph.

The overall test length of the installation was 64 ft.- 6 3/4 in. The installation consisted for four major components: (1) concrete safety shape, bridge rail end-section, (2) the w-beam approach guardrail section, (3) the w-beam breakaway end anchorage, and (4) the w-beam terminal connector.

The concrete end-section was 7 ft. long and 2 ft.- 8 in. high. A 6-in. concrete curb was constructed 13 ft. beyond the end of the concrete end-section.

The w-beam approach guardrail section consisted of 62 ft.- 6 in. of 12 gauge standard w-beam. The top of the w-beam was installed at a mounting height of 27-in. The w-beam was supported by 13 timber posts. The design consisted of three 10-in. by 10-in. posts, eight 8-in. by 8-in. posts, and two 6-in. by 8-in. posts. The post spacing between post 1 through 7 and 7 through 13 was 3 ft.- 1 1/2 in. and 6 ft.- 3 in., respectively.

The point of impact was 15 ft. upstream from the end of the concrete end-section between posts 5 and 6.

The test was evaluated according to the safety criteria in NCHRP 230 and also in the AASHTO guide specifications. The safety performance of the Iowa W-Beam Approach Guardrail Transition Section was determined to be satisfactory.

## TABLE OF CONTENTS

|   | Page |
|---|------|
| Abstract .....                                      | i    |
| Table of Contents .....                             | ii   |
| List of Tables .....                                | iv   |
| List of Figures .....                               | v    |
| Acknowledgements .....                              | vii  |
| 1. INTRODUCTION .....                               | 1    |
| 1.1. Problem Statement .....                        | 1    |
| 1.2. Objective of Study .....                       | 1    |
| 2. TEST CONDITIONS .....                            | 2    |
| 2.1. Test Facility .....                            | 2    |
| 2.1.1. Test Site .....                              | 2    |
| 2.1.2. Vehicle Tow System .....                     | 2    |
| 2.1.3. Vehicle Guidance System .....                | 2    |
| 2.2. W-Beam Approach Guardrail Design Details ..... | 6    |
| 2.3. Test Vehicle .....                             | 19   |
| 2.4. Data Acquisition Systems .....                 | 22   |
| 2.4.1. Accelerometers .....                         | 22   |
| 2.4.2. High-Speed Photography .....                 | 25   |
| 2.4.3. Speed Trap Switches .....                    | 25   |

|   | Page |
|---|------|
| 2.5. Test Parameters .....  | 27   |
| 3. PERFORMANCE EVALUATION CRITERIA .....  | 28   |
| 4. TEST RESULTS .....   | 32   |
| 4.1. Test No. I6-1 .....  | 32   |
| 5. CONCLUSIONS .....  | 44   |
| 6. RECOMMENDATIONS .....  | 48   |
| 7. REFERENCES .....   | 49   |
| 8. APPENDICES .....   | 50   |
| APPENDIX A. CONCRETE COMPRESSIVE STRENGTHS<br>AND DESIGN MIX SPECIFICATIONS ..... | 51   |
| APPENDIX B. RELEVANT IDOT CORRESPONDENCE .....                                    | 57   |
| APPENDIX C. ACCELEROMETER DATA ANALYSIS .....                                     | 59   |

## LIST OF TABLES

|  | Page |
|--|------|
| 1. Crash Test Conditions and Evaluation Criteria for the Iowa Approach |      |
| Guardrail Transition Section .....                                     | 29   |
| 2. NCHRP 230 Evaluation Criteria .....                                 | 30   |
| 3. AASHTO Evaluation Criteria .....                                    | 31   |
| 4. NCHRP 230 Evaluation Criteria .....                                 | 45   |
| 5. AASHTO Evaluation Criteria .....                                    | 46   |

## LIST OF FIGURES

|   | Page |
|---|------|
| 1. Full-Scale Crash Test Facility .....                         | 3    |
| 2. Sketch of Cable Tow and Guidance System .....                | 4    |
| 3. Photographs of Tow Vehicles and Fifth Wheel .....            | 5    |
| 4. Sketch of Concrete End-Section .....                         | 7    |
| 5. Sketch of Guardrail Installation Bridge Approach .....       | 8    |
| 6. Sketch of Guardrail to Post Attachment .....                 | 9    |
| 7. Sketch of W-Beam Terminal Connector .....                    | 10   |
| 8. Sketch of Breakaway End Anchorage .....                      | 11   |
| 9. Sketch of Formed Steel Terminal Sections .....               | 12   |
| 10. Sketch of Concrete Curb and Attachment .....                | 13   |
| 11. Sketch of Guardrail Installation Bridge Approach .....      | 14   |
| 12. Detail of Post Embedment and W-Beam Attachment .....        | 15   |
| 13. Photographs of W-Beam Approach Guardrail Installation ..... | 16   |
| 14. Photographs of W-Beam Approach Guardrail Installation ..... | 17   |
| 15. Photographs of Test Vehicle .....                           | 20   |
| 16. Vehicle Measurements .....                                  | 21   |
| 17. Flowchart of Accelerometer Data Acquisition Systems .....   | 23   |
| 18. Data Recorder and 386/AT Computer .....                     | 25   |
| 19. Layout of High-Speed Cameras .....                          | 26   |
| 20. Test I6-1 Summary and Sequential Photographs .....          | 33   |

|  | Page |
|--|------|
| 21. (a) Time-Sequential Photographs .....      | 34   |
| (b) Time-Sequential Photographs .....          | 35   |
| (c) Time-Sequential Photographs .....          | 36   |
| 22. Photographs of Vehicle Damage .....        | 37   |
| 23. Photographs of Damage to Approach          |      |
| Guardrail Transition Section .....             | 39   |
| 24. Photographs of Damage to Approach          |      |
| Guardrail Transition Section .....             | 40   |
| 25. Photographs of Damage to Approach          |      |
| Guardrail Transition Section .....             | 41   |
| 26. Photographs of Damage to Approach          |      |
| Guardrail Transition Section .....             | 42   |
| 27. Graph of Permanent Set Displacements ..... | 43   |



## ACKNOWLEDGEMENTS

The authors wish to express their appreciation and thanks to the following people who made a contribution to the outcome of this research project.

### Iowa Department of Transportation

This evaluation task was administered and directed by William A. Lundquist, Bridge Engineer for the Iowa Department of Transportation, who was assisted by IDOT engineers David L. Little and Ron C. Welch.

### Federal Highway Administration

The Iowa Division Office of the Federal Highway Administration was represented by Bruce L. Brakke, Division Bridge Engineer, and John M. Latterell, Division Safety Engineer, who cooperated and advised during the evaluation.

### University of Nebraska-Lincoln

Ron Hoffman (Electrician - Maintenance)  
Michael Cacak (Manager - Automobile Support Services)  
Patrick Barrett (Assistant Manager - Automobile Support Services)  
James Dunlap (Manager - Photographic Productions)  
Gerald Fritz (E.E. Technician)  
Tom Grady (E.E. Technician)  
William E. Kelly (Professor and Chairman, Civil Engineering)  
Eugene Matson (C.E. Research Technician)  
Jim McManis (Supervisor - Engineering Shop)  
Tom Hoffman (Instrument Maker III - Engineering Shop)  
Ed Itzen (Instrument Maker III - Engineering Shop)  
Jack Somers (Instrument Maker III - Engineering Shop)  
Virgil Oligmueller (C.E. Student)  
Craig Rockwell (C.E. Work-Study)  
Wang Naitai (C.E. Ph.D. Student)  
Mary Lou Tomka (C.E. Administrative Assistant)  
Wilma Ennenga (C.E. Research Analyst)  
Patricia Pedersen (C.E. Secretary)

### Private

Larry Storjahnn (Auto Buyer)  
Mike Collins (M.E. Collins Construction)  
Steve Buchanan (M.E. Collins Construction)  
John Magdaleno (Formerly at UNL, now at General Motors)

## 1. INTRODUCTION

### 1.1. Problem Statement

The Iowa Department of Transportation (IDOT) and the Federal Highway Administration (FHWA) are concerned with the safety and structural adequacy of highway and bridge railing systems installed on Iowa highways. The performance of certain Iowa Railing systems, now in service, cannot be predicted or verified by conventional analysis.

The current *AASHTO Standard Specifications for Highway Bridges* permits the qualification of railing systems by full-scale vehicle crash testing. The Federal Highway Administration has directed that bridge railing systems be successfully crash tested before their use on Federal Aid Projects is approved.

The Iowa W-Beam Approach Guardrail Transition Section is currently installed on the Iowa Primary and Interstate Systems. Thus, full-scale vehicle crash testing was to be performed to evaluate the structural adequacy, occupant risk, and redirection characteristics.

The results of this study will be used to assist the IDOT in the identification and evaluation of procedures to improve the safety of the roadway environment.

### 1.2. Objective of Study

The objective of the research study was to evaluate the safety performance of the Iowa W-Beam Approach Guardrail Transition Section by conducting a full-scale vehicle crash test in accordance with the "Recommended Procedures for the Safety Performance Evaluation of Highway Appurtenances," NCHRP 230 (1) and also in the "Guide Specifications for Bridge Railings," AASHTO (2).

## 2. TEST CONDITIONS

### 2.1. Test Facility

#### 2.2.1. Test Site

The test site facility was located at Lincoln Air-Park on the NW end of the west apron of the Lincoln Municipal Airport. The test facility, shown in Figure 1, is approximately 5 mi. NW of the University of Nebraska-Lincoln.

An 8 ft. high chain-link security fence surrounds the test site facility to ensure that no vandalism occurs to the test articles or test vehicles which could possibly disrupt the results of the tests.

#### 2.1.2. Vehicle Tow System

A reverse cable tow, with a 1:2 mechanical advantage, was used to propel the test vehicle. The distance traveled and the speed of the tow vehicle are one-half that of the test vehicle. A sketch of the cable tow system is shown in Figure 2. The test vehicle was released from the tow cable approximately 18 feet before impact with the W-Beam Approach Guardrail Transition Section. Photographs of the tow vehicle and the attached fifth-wheel are shown in Figure 3. The fifth-wheel, built by the Nucleus Corporation, was used for accurately towing the test vehicle at the required target speed with the aid of a digital speedometer in the tow vehicle.

#### 2.1.3. Vehicle Guidance System

A vehicle guidance system, developed by Hinch (3), was used to steer the test vehicle. A sketch of the guidance system is shown in Figure 2. The Guide flag, attached to the front left wheel and the guide cable, was sheared off 18 feet before impact with the W-Beam

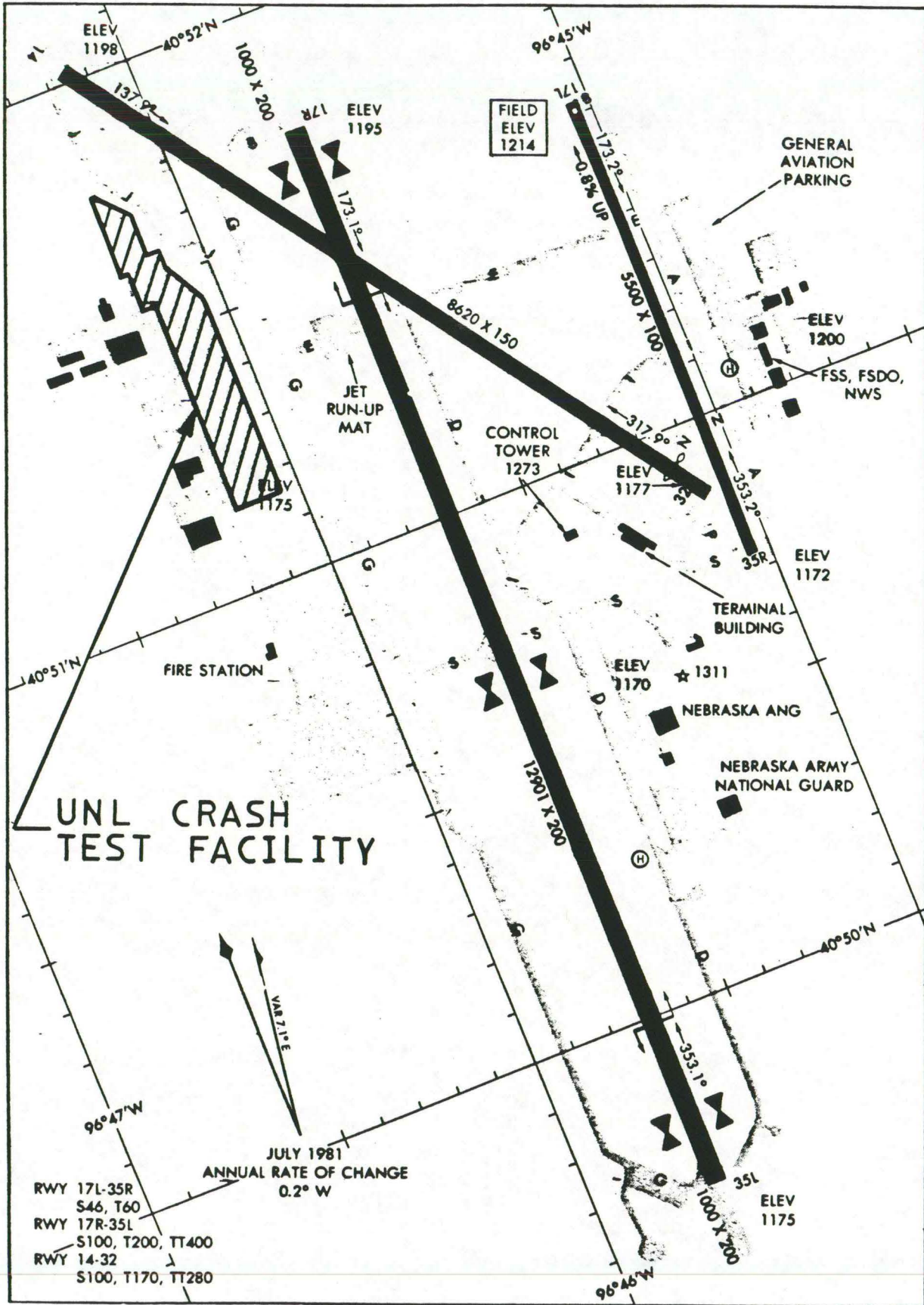

FIGURE 1. FULL-SCALE CRASH TEST FACILITY.

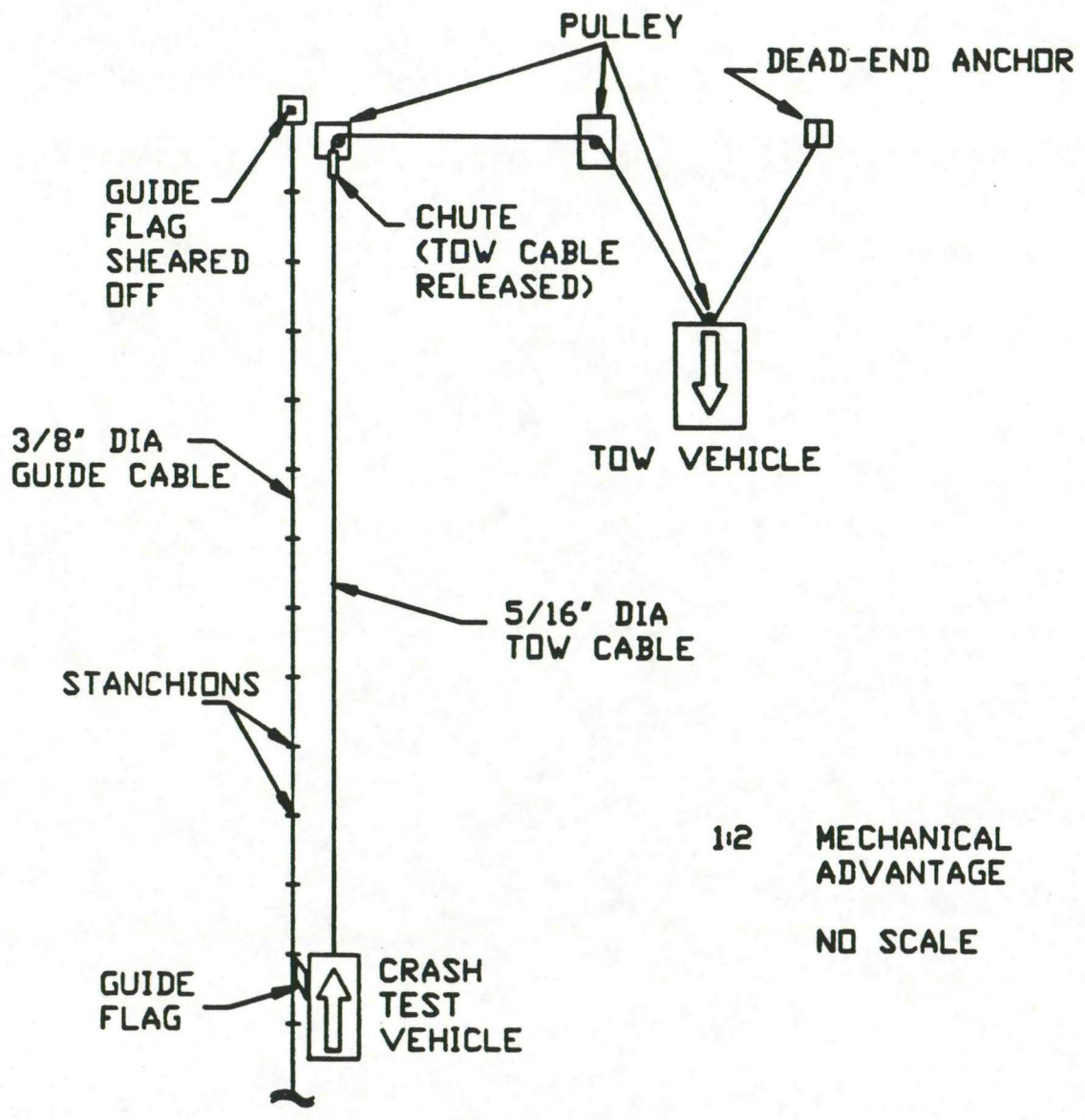
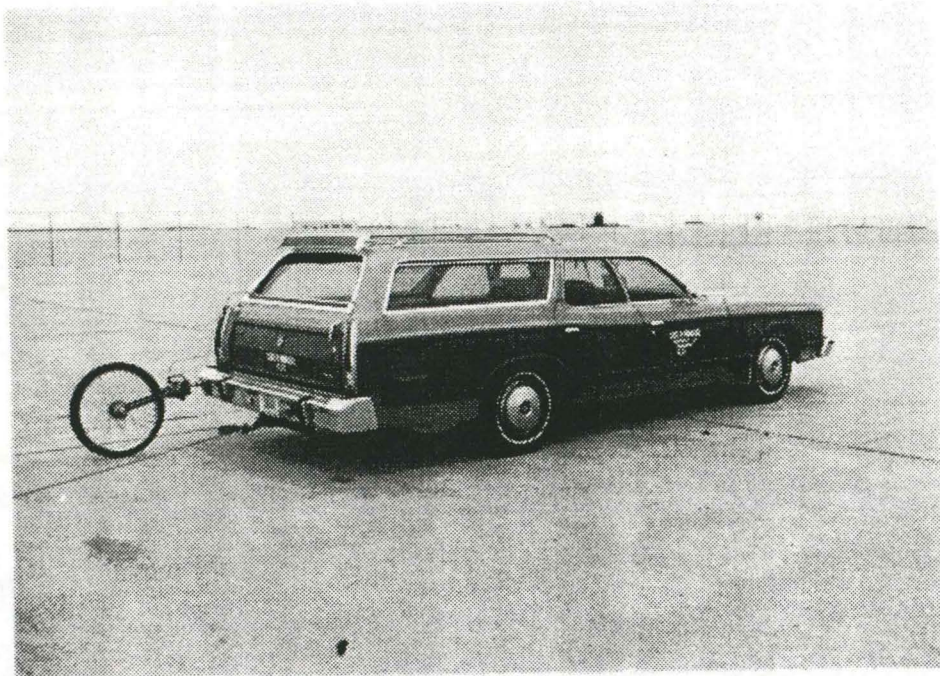

FIGURE 2

SKETCH OF CABLE TOW AND GUIDANCE SYSTEMS



---

FIGURE 3. PHOTOGRAPH OF TOW VEHICLE AND FIFTH WHEEL

Approach Guardrail Transition Section. The 3/8-in. diameter guide cable was tensioned to 3,000 pounds, and it was supported laterally and vertically every 100 ft. by hinged stanchions. The hinged stanchions stood upright while holding up the guide cable. When the vehicle passed, the guide-flag struck each stanchion and knocked it to the ground. The vehicle guidance system was approximately 1,500 ft. in length.

## **2.2. W-Beam Approach Guardrail Design Details**

The design drawing details of the Iowa W-Beam Approach Guardrail Transition Section are shown in Figures 4 through 12, and photographs of the installation before impact are shown in Figures 13 and 14.

The overall length of the installation was 64 ft.- 6 3/4 in. The installation consisted for four major components: (1) the concrete safety shape, bridge rail end-section, (2) the w-beam approach guardrail section, (3) the w-beam breakaway end anchorage, and (4) the w-beam terminal connector.

The concrete safety shape, bridge rail end-section was constructed with a Nebraska Class 47-B-PHE mix design (see Appendix A). The concrete compressive strength at the time of the crash test averaged about 3,700 psi (see Appendix A). The concrete end-section was 7 ft. long and 2 ft.- 8 in. high. The width of the concrete end-section varied relative to the location of the cross-section, as shown in Figure 4. The concrete end-section was anchored 15-in. into the existing airport concrete apron by 2 No. 5 rebar dowels, spaced at 13-in. on centers over the length of the concrete end-section. An epoxy grout material was used as the bonding agent for the dowels.

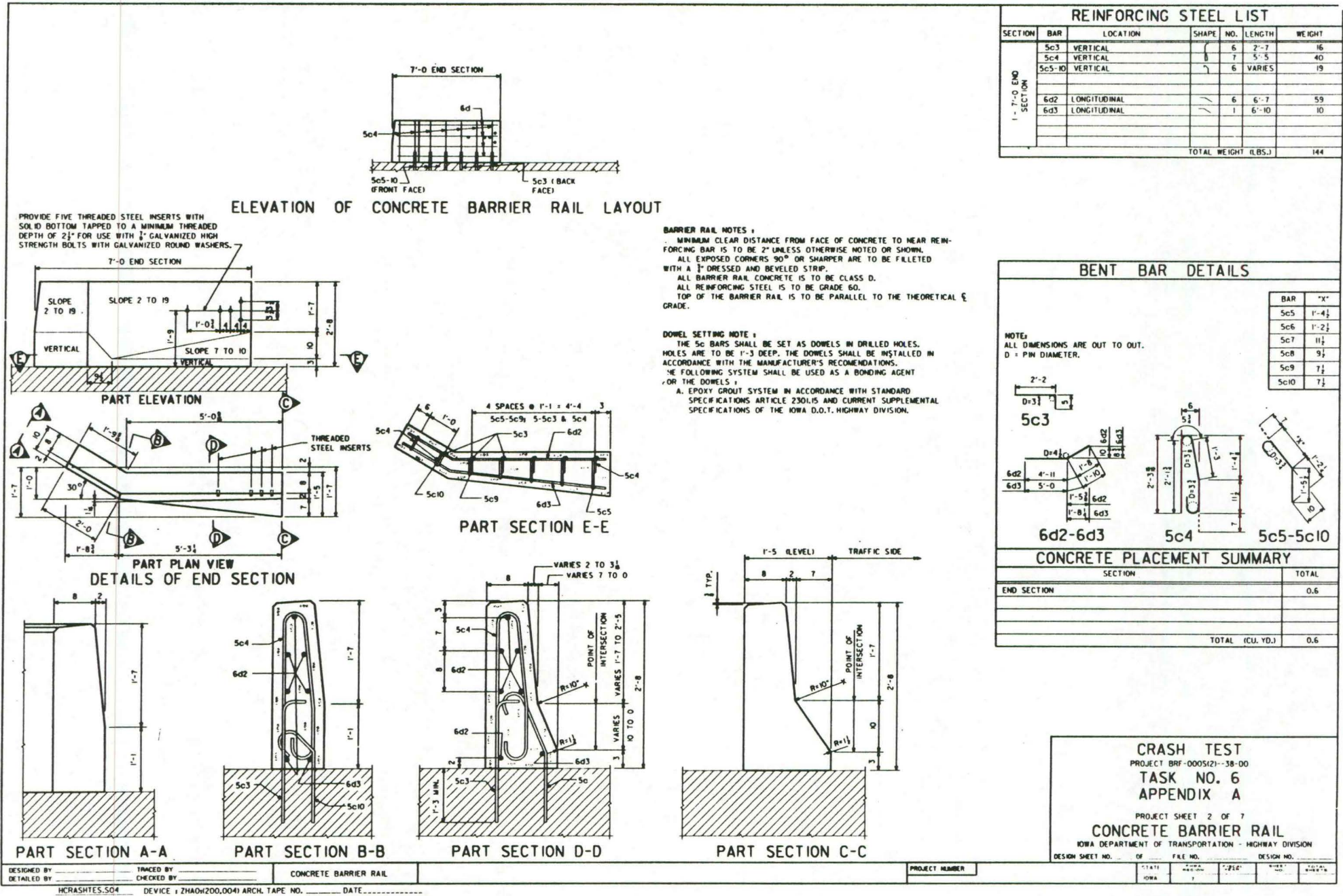
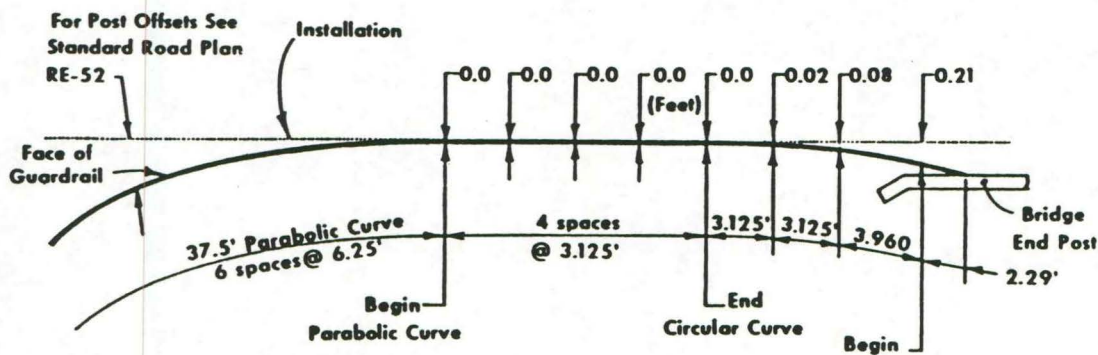
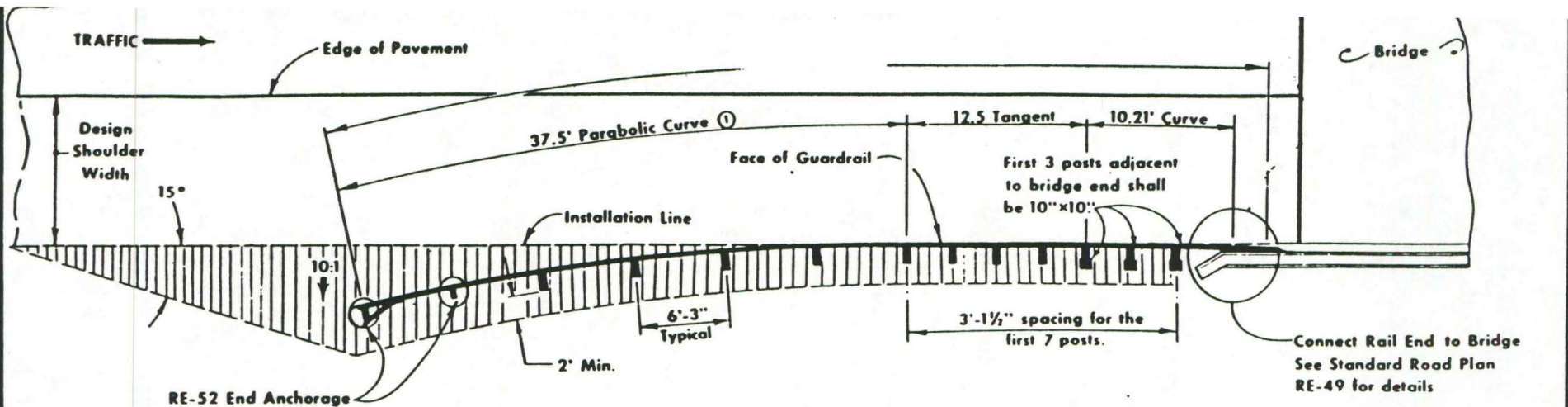

FIGURE 4. SKETCH OF CONCRETE END-SECTION.





OFFSETS FOR CURVED PORTION OF GUARDRAIL

**GENERAL NOTES:**

Details indicated hereon are for the typical installation of guardrail at approaches to bridges constructed with concrete barrier rail. Refer to project plans, including Tabulation of Beam Guardrail Installations as well as other Standard Road Plans for additional requirements for individual installations.

Horizontal and vertical alignment of the guardrail in the area immediately adjacent to the bridge shall, where necessary, be adjusted to a smoothly curved line with no abrupt changes.

Guardrail shall be lapped towards the structure.

① Refer to standard Road Plan RE-52 for details of Parabolic Curve Section.

FIGURE 5. SKETCH OF GUARDRAIL INSTALLATION BRIDGE APPROACH.

CRASH TEST  
 Project BRF-0005(12)--38-00  
 TASK No. 6  
 APPENDIX A  
 Project Sheet 3 of 7

GUARDRAIL INSTALLATION  
 BRIDGE APPROACH  
 (BRIDGE WITH CONCRETE BARRIER RAIL)

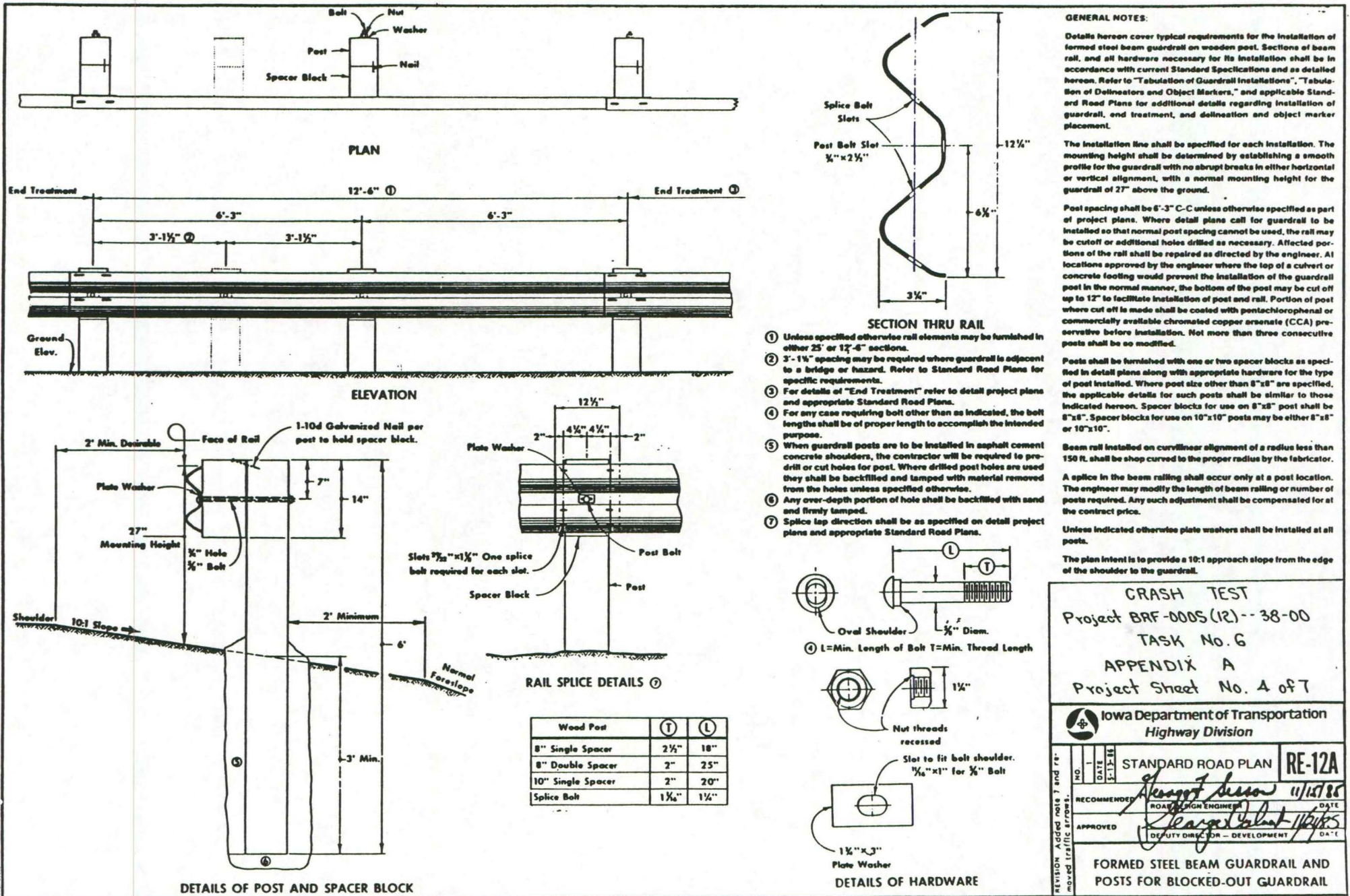

FIGURE 6. SKETCH OF GUARDRAIL TO POST ATTACHMENT.

CRASH TEST  
Project BRP-0005 (12) -- 38-00  
TASK No. 6  
APPENDIX A  
Project Sheet No. 4 of 7

Iowa Department of Transportation  
Highway Division

|             |          |                               |        |
|-------------|----------|-------------------------------|--------|
| NO.         | DATE     | STANDARD ROAD PLAN            | RE-12A |
| RECOMMENDED | 11/15/88 | ROAD ENGINEER                 | DATE   |
| APPROVED    |          | DEPUTY DIRECTOR - DEVELOPMENT | DATE   |

FORMED STEEL BEAM GUARDRAIL AND  
POSTS FOR BLOCKED-OUT GUARDRAIL

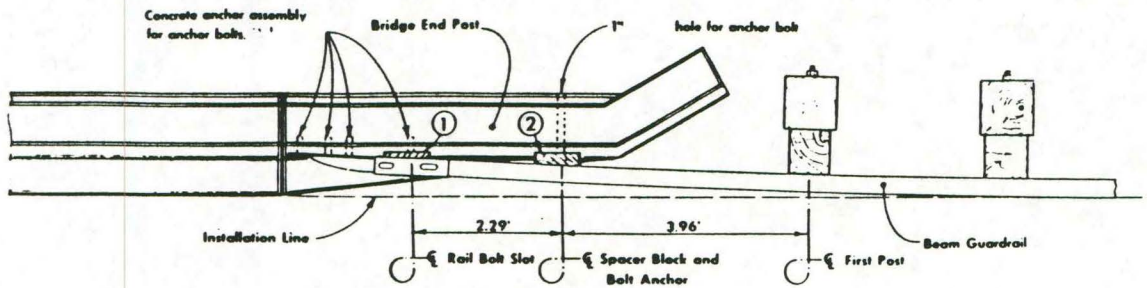

TYPICAL PLAN

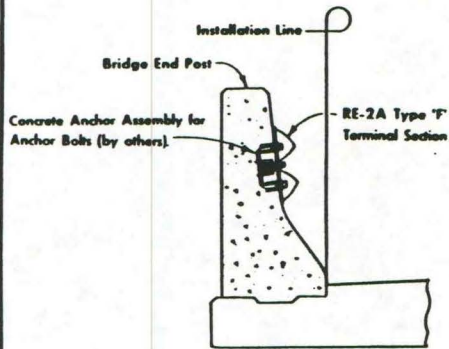

SECTION A-A

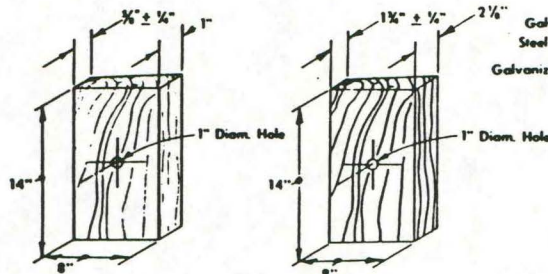

SPACER BLOCK DETAILS

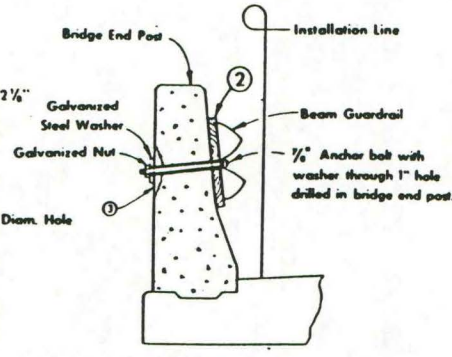

SECTION B-B

① Area on back face spalled in drilling hole will be grouted before placement of washer for bolt installation.



LAPPING PROCEDURE

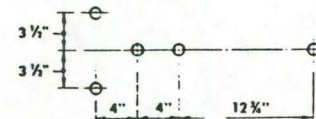

BOLT PATTERN

For RE-2A Type F Terminal Section

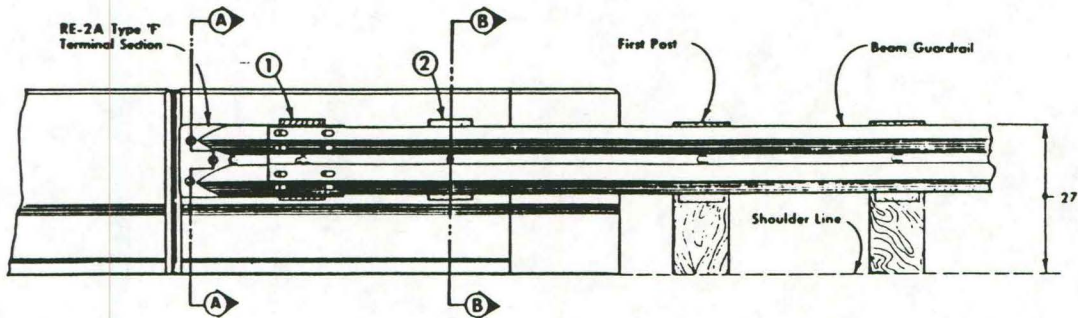

TYPICAL ELEVATION

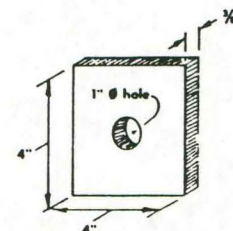

DETAIL OF GALVANIZED STEEL WASHER

GENERAL NOTES:

The intent of this plan is to show the attachment of beam guardrail to the bridge end post using all the required connecting devices indicated hereon. Refer to "Tabulation of W Beam Guardrail Installations" and applicable Standard Road Plans for additional details regarding installation of guardrail.

Any materials not specifically detailed hereon shall be in accordance with other appropriate Standard Road Plans as well as current Standard Specifications.

The anchor bolts shall conform to requirements of ASTM A 325 or A449, threaded full length and shall be galvanized in compliance with ASTM A-153. Threads may be chased after galvanizing.

Washers shall be made of steel and shall meet the dimensional requirements of A.N.S.I. B27.2 type A plain washers.

Horizontal and vertical alignment of the guardrail in the area immediately adjacent to the bridge shall be adjusted to a smoothly curved line with no abrupt changes. Exact details of the installation shall be as directed by the engineer.

The RE-49 Guardrail-Bridge Connection shall not be measured for payment. The construction indicated including the furnishing of the RE-2A, Type "F" terminal section, shall be considered incidental to other guardrail work on the project.

LIST OF MATERIALS FOR THE RE-49 BRIDGE CONNECTION

- 5 - Approved 7/8"x2-1/2" H.S. Hex Bolts.
- 5 - Approved 15/16" I.D., 2-1/4" O.D., 5/32" Thick Washers.
- 1 - Approved 7/8" x Sufficient length H.S. Hex Bolt.
- 1 - Galvanized Steel Washer (4" x 4" x 3/8").
- 1 - RE-2A Type "F" Terminal Section.
- 2 - Spacer Blocks (as detailed).

|   |       |
|---|-------|
| TASK No. 6<br>APPENDIX A<br>Project Sheet No. 5 of 7              |       |
| Iowa Department of Transportation<br>Highway Division             |       |
| STANDARD ROAD PLAN<br>NO. 1110                                    | RE-49 |
| RECOMMENDED<br>ROAD DESIGN ENGINEER<br>George T. Swann 11/10/86   | DATE  |
| APPROVED<br>DEPUTY DIRECTOR - DEVELOPMENT<br>[Signature] 11/10/86 | DATE  |
| DETAILS OF GUARDRAIL TO BRIDGE<br>CONNECTION WITH BARRIER CURB    |       |

FIGURE 7. SKETCH OF W-BEAM TERMINAL CONNECTOR.

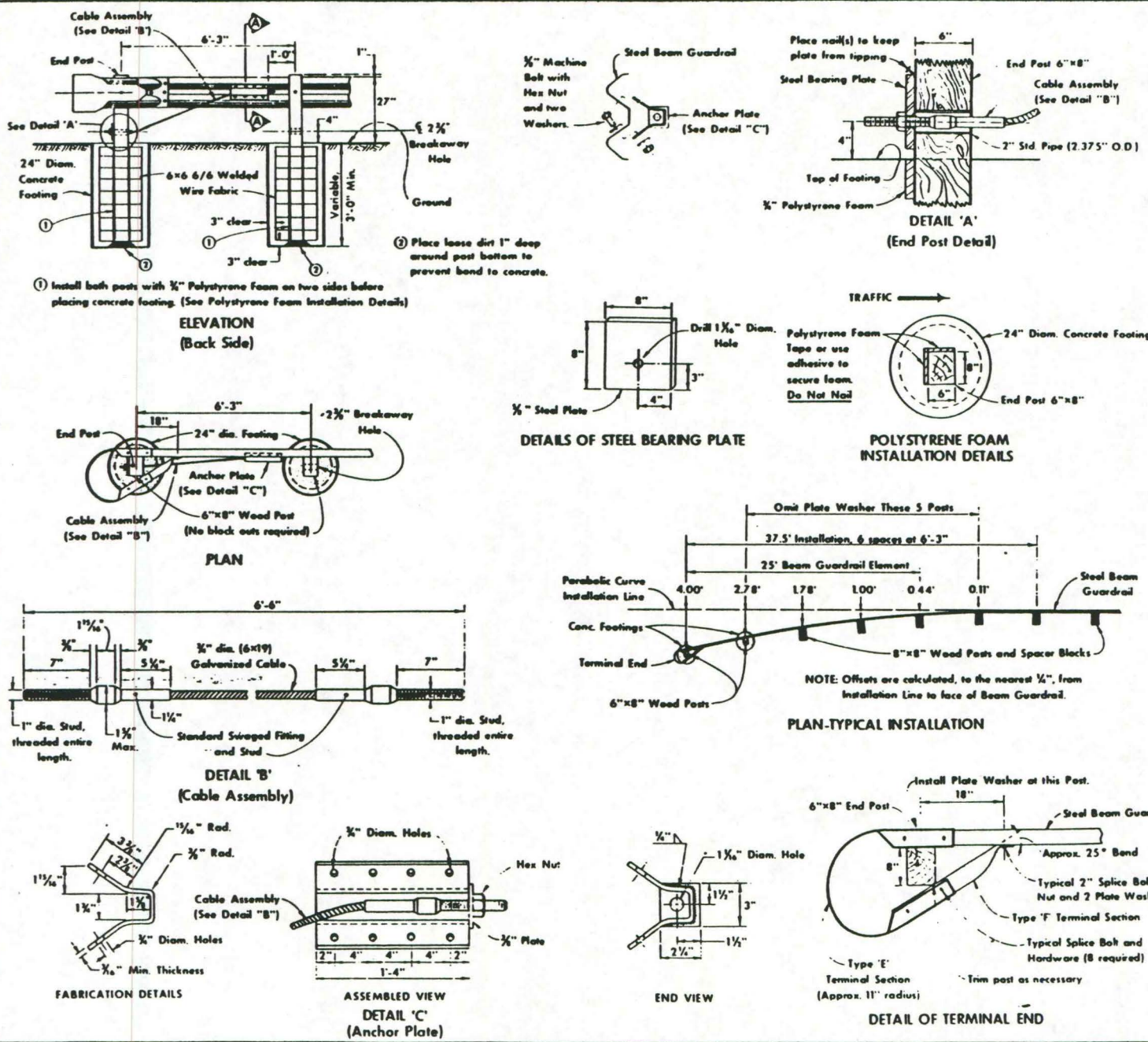

**GENERAL NOTES:**

The details indicated hereon are for an end anchorage system for beam guardrail. Beam guardrail and posts are not part of this end anchorage. Refer to guardrail tabulations and applicable Standard Road Plans and current specifications for additional details regarding installation of guardrail.

Alternate details and items not specifically covered by specifications shall be submitted to the engineer for approval.

Cable assembly and anchor plate shall be approved by the engineer and shall have a minimum breaking strength of 20 tons.

All fittings and hardware required shall be galvanized after fabrication.

Concrete for anchor shall meet the requirements for Class "C" Structural Concrete.

The 6"x8" post required for the end anchorage shall have the following dimensional tolerance:

6" (tolerance + 1/4")  
8" (tolerance + 1/2")

Gas Metal-Arc and Flux-Cored Arc welding may be used for welding incidental items as indicated on this sheet, provided that the fabricator furnishes certifications for the filler metal and gas, uses prequalified welding procedures, and qualified welders approved by the Iowa D.O.T.

**TASK No. 6**  
**APPENDIX A**  
**Project Sheet No. 6 of 7**

- LIST OF MATERIALS**  
**FOR GUARDRAIL, END ANCHORAGES, BEAM RE-52**
- 1-Type "F" Terminal Section (RE-2A)
  - 1-Type "E" Terminal Section (RE-2A)
  - 1-Anchor Plate with required fasteners
  - 1-Cable Assembly, fabricated as shown hereon including all necessary hardware
  - 1-2.375" O.D. x 6" Pipe
  - 8"x8"x1/2" Steel Bearing Plate, fabricated as detailed
  - 10'x3' Wire Mesh Reinforcing Steel (Approx.)
  - 2-Footings, 3' Depth-0.62 Cu. Yds. of Class "C" Structural Concrete
  - 4-Polystyrene Foam Pieces (2-1/2" x 6-1/2" x 36" min.) (2-1/2" x 9-1/2" x 36" min.)

|  |  |                    |          |        |
|--|--|--------------------|----------|--------|
|  |  | STANDARD ROAD PLAN |          | RE-52  |
|  |  | DATE               | 07-27-87 | DATE   |
| RECOMMENDED  |  |                    | DATE     | 3/1/87 |
| APPROVED   |  |                    | DATE     |        |
| <b>DETAILS OF BEAM GUARDRAIL BREAKAWAY END ANCHORAGE</b> |  |                    |          |        |

FIGURE 8. SKETCH OF BREAKAWAY END ANCHORAGE.

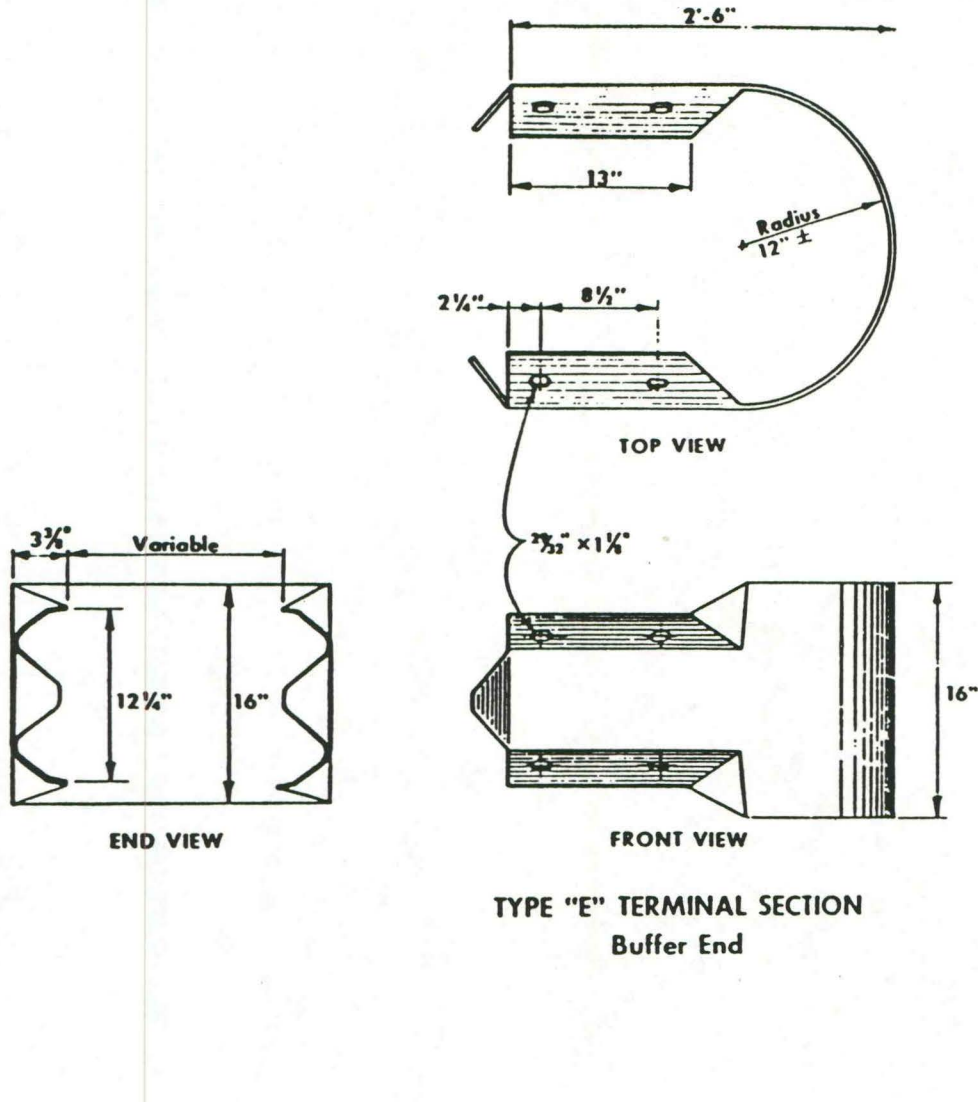

**GENERAL NOTES:**

Terminal section shall be required as part of the end treatment for all guardrail installations unless specifically indicated otherwise in project plans.

Fabrication and installation of terminal sections shall be in accordance with current Iowa D.O.T. Standard Specifications and appropriate other standard road plans.

Refer to "Tabulation of Guardrail Installations" for additional details of installations.

Type "E" and "F" terminals shall be U.S.S. 10 gage.

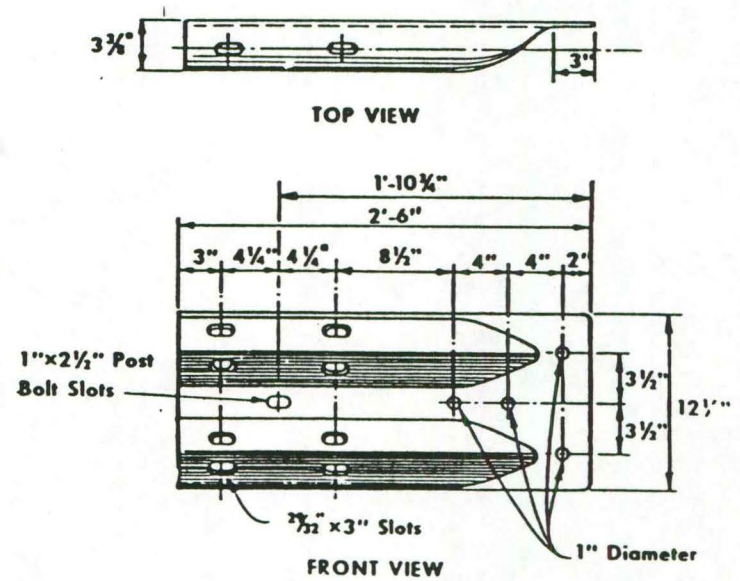
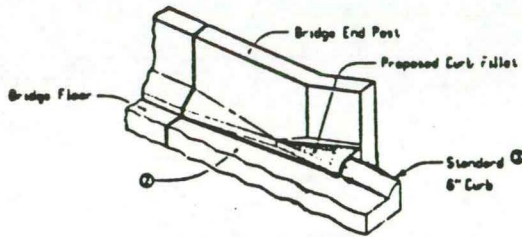

FIGURE 9. SKETCH OF FORMED STEEL TERMINAL SECTIONS.

CRASH TEST  
Project BRP-0005 (12)--38-00  
TASK No. 6  
APPENDIX A  
Project Sheet No. 7 of 7

FORMED STEEL BEAM RAILING  
TERMINAL SECTIONS



- ② Reinforced Bridge Approach Section.
- ③ Build 6" curb to end of Reinforced Bridge Approach Section. The location of the guardrail determines the location of the curb. The back of curb is located 8" back of the face of guardrail.

**DETAIL "C"**  
Joint and Curb Fillet  
at Bridge End Section

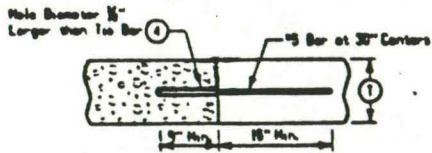
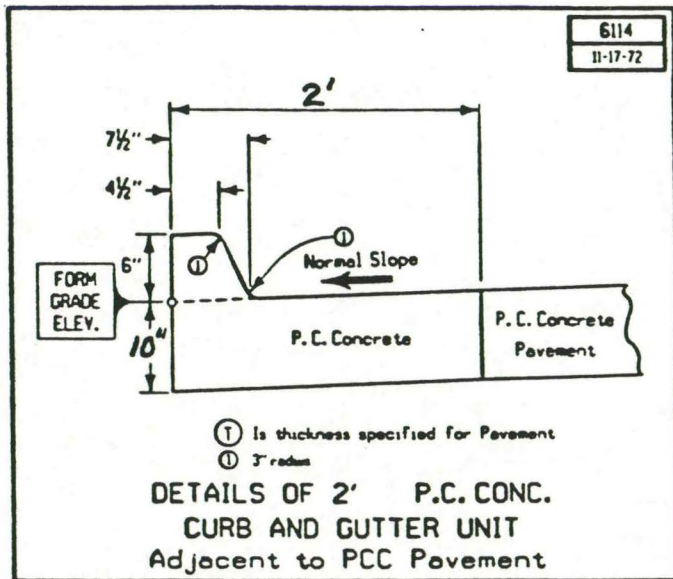

- ② When tying into old pavement, ① represents the depth of sound concrete.
- ④ Placement of dowels or tie bars shall be in accordance with Standard Specification 2301.15. The method of anchoring bars into existing pavement shall be as approved by the engineer as set forth in appropriate Materials Instructional Memorandum.

**'BT-3'**  
ABUTTING PAVEMENT JOINT, RIGID TIE  
(FORMERLY 'BD' JOINT)

FIGURE 10. SKETCH OF CONCRETE CURB AND ATTACHMENT.

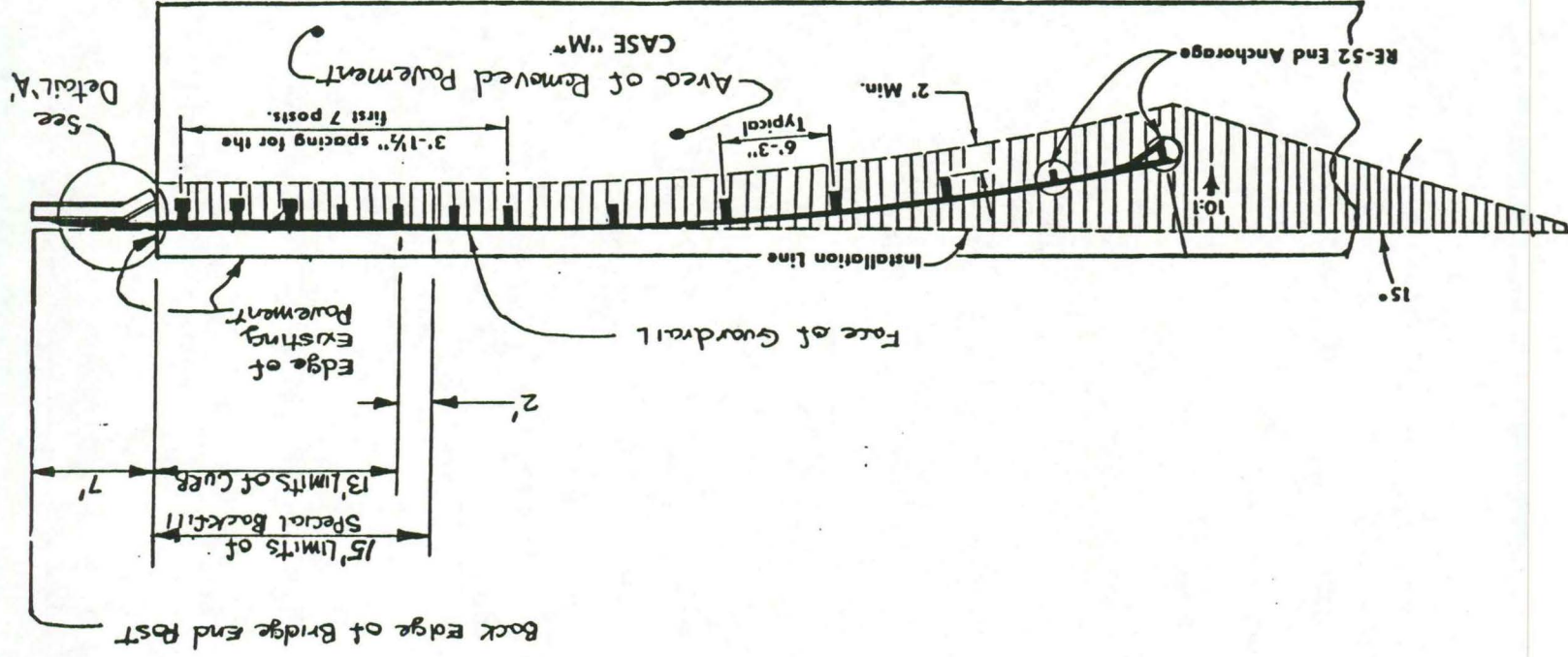

FIGURE 11. SKETCH OF GUARDRAIL INSTALLATION BRIDGE APPROACH.

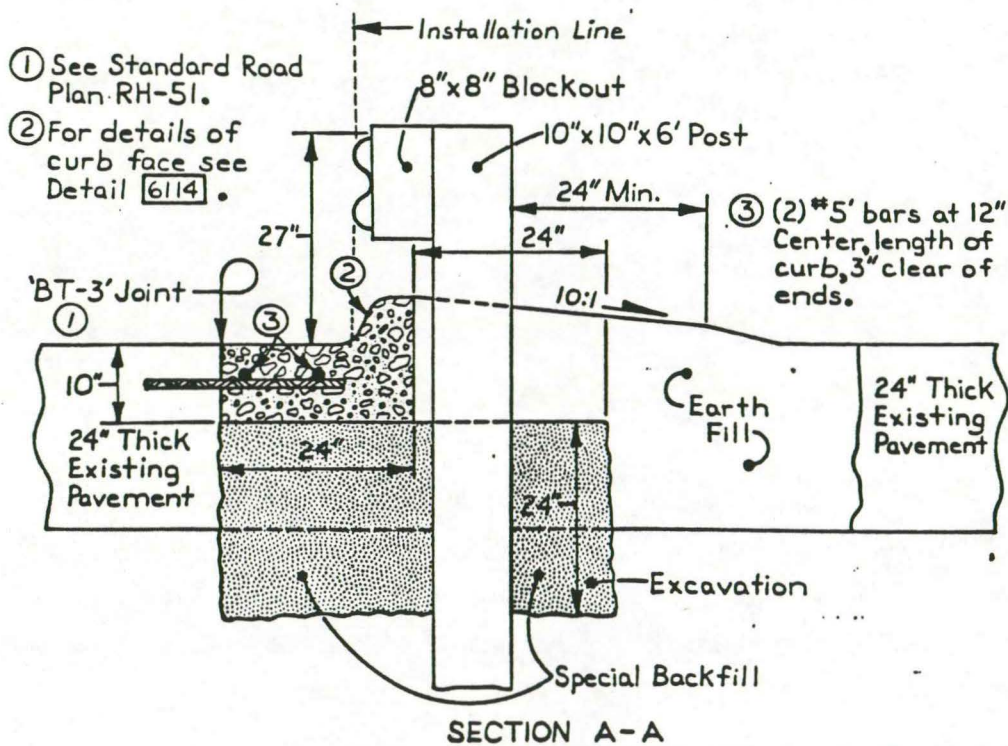
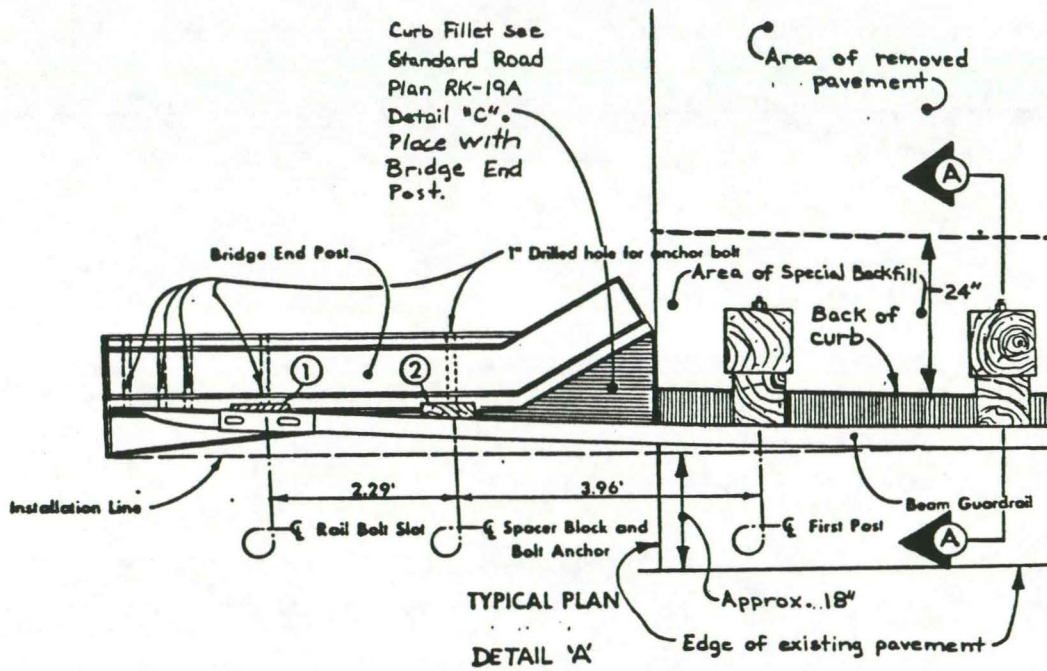

FIGURE 12. DETAIL OF POST EMBEDMENT AND W-BEAM ATTACHMENT.



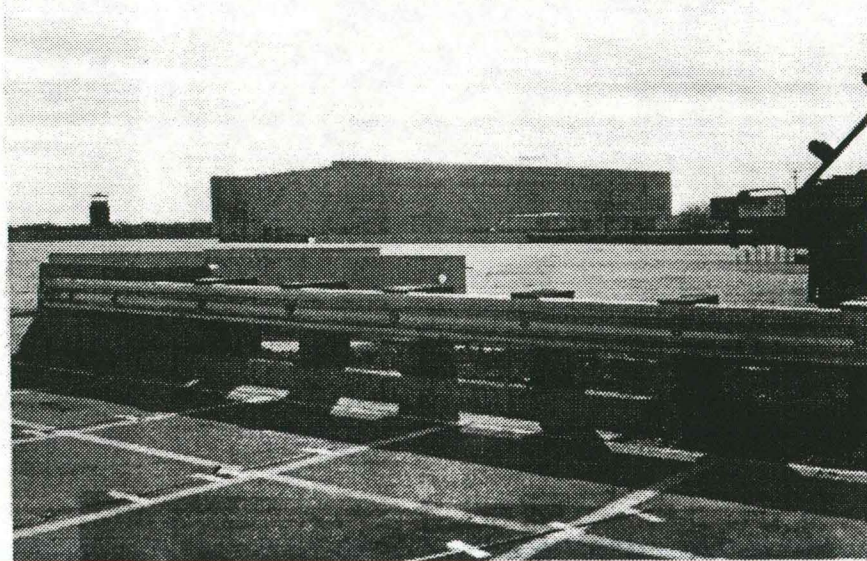
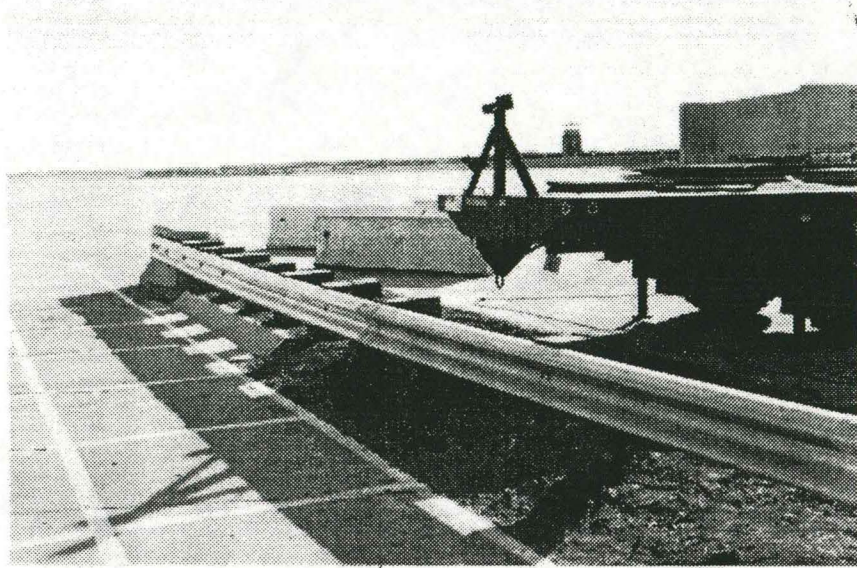
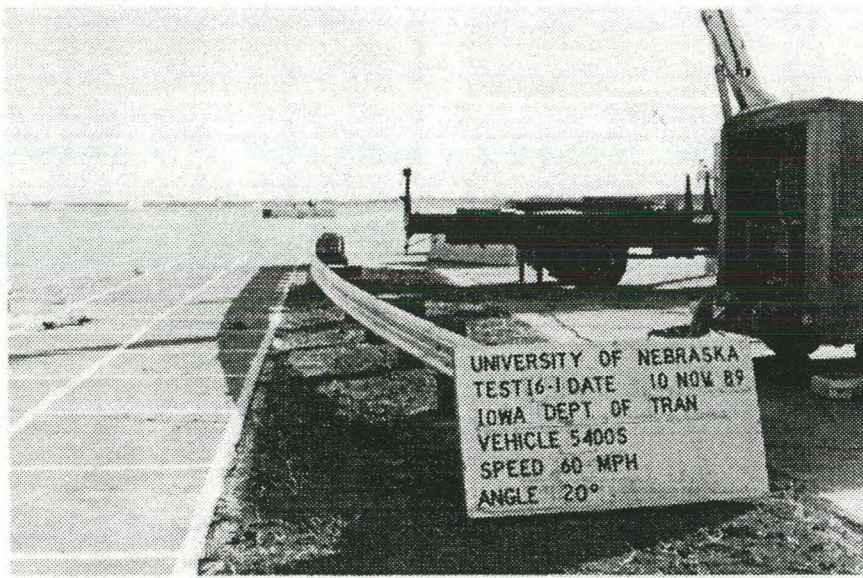

FIGURE 13. PHOTOGRAPHS OF W-BEAM APPROACH GUARDRAIL INSTALLATION.

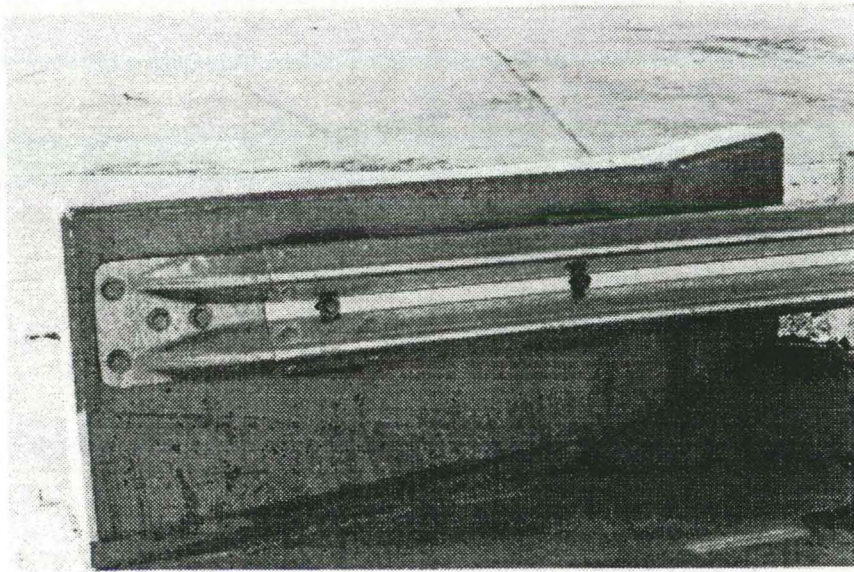

FIGURE 14. PHOTOGRAPHS OF W-BEAM GUARDRAIL APPROACH INSTALLATION.

A concrete curb was constructed 13 ft. beyond the end of the concrete end-section, as shown in Figures 10 through 12. The curb was 6-in. high and had a top width and bottom width of 4 1/2-in. and 7 1/2-in., respectively. The curb was constructed with a concrete slab which was 10-in. deep and 24-in. wide. The concrete slab was anchored 9-in. into the edge of the existing airport concrete apron by No. 5 rebar dowels, spaced at 30-in. on centers over the length of the 13 ft. concrete curb and slab section. An epoxy grout material was used as the bonding agent for the dowels.

The w-beam approach guardrail section consisted of 62 ft.- 6 in. of 12 gauge standard w-beam. The w-beam section was 12 3/4-in. wide and 3 1/4-in. deep, as shown in Figure 6. The w-beam was installed at a mounting height of 27-in., as measured to the top of the w-beam. This is shown in Figures 6 and 12. The back of the concrete curb was located 8-in. back of the face of the w-beam guardrail.

The w-beam guardrail was supported by 13 timber posts, as shown in Figures 5 and 11. The first 3 posts adjacent to the concrete end-section were 10-in. by 10-in. by 72-in. The next 8 posts were 8-in. by 8-in. by 72-in. The last 2 posts, which were part of the breakaway end anchorage system, were 6-in. by 8-in. by 72-in. An 8-in. by 8-in. by 14-in. timber spacer block was used for the first 11 timber posts. The spacer block attachment detail is shown in Figure 6. The post spacing between posts 1 through 7 was 3 ft.- 1 1/2 in., and the post spacing between posts 7 through 13 was 6 ft.- 3 in., as shown in Figures 5 and 11.

The timber posts were embedded into two different materials, as shown in Figure 12. The upper layer consisted of a "native," silty-clay earth fill. The lower layer consisted of a

special gravel backfill. The special gravel backfill had the following gradation requirements: 100% passing the no. 1 1/2-in sieve, 45-80% passing the no. 4 sieve, and 4-12% passing the no. 200 sieve.

The w-beam breakaway end anchorage system was located at posts 12 and 13, as shown in Figures 5, 8, and 11. The two posts were embedded in concrete footings, as shown in Figure 8. The breakaway end anchorage system used a steel cable and anchor assembly which increased the load carrying capability of the w-beam. A 10 gauge, Type "E" terminal end section was used at post 13, as shown in Figures 8 and 9.

The w-beam terminal connector was used to attach the w-beam guardrail to the concrete end-section, as shown in Figures 7, 9, and 12. A 10 gauge, Type "F" terminal connector was installed. The section was 12 1/4-in. wide by 30-in. long.

### **2.3. Test Vehicle**

One test vehicle was used to evaluate the Iowa W-Beam Approach Guardrail Transition Section. For Test I6-1, a 1983 Ford F-250 pickup weighing 5,420 lbs. was used as the crash test vehicle. Photographs of the test vehicle are shown in Figure 15. Dimensions of the test vehicle are shown in Figure 16.

Steel plates, bolted to the rear box, were used in order for the test vehicle to conform to the weight and the center-of-mass specifications in AASHTO (2).

The front wheels of the test vehicle were aligned to a toe-in value zero-zero so that the vehicle would track properly along the guide cable.

Three 8-in. square, black and white checkered targets were placed on the centerline of the top of the test vehicle. The middle target was placed over the center of mass.

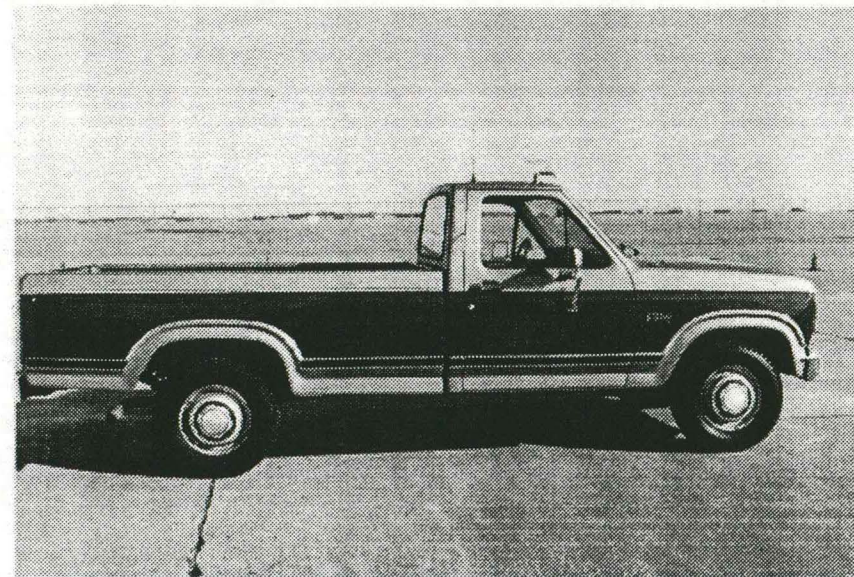
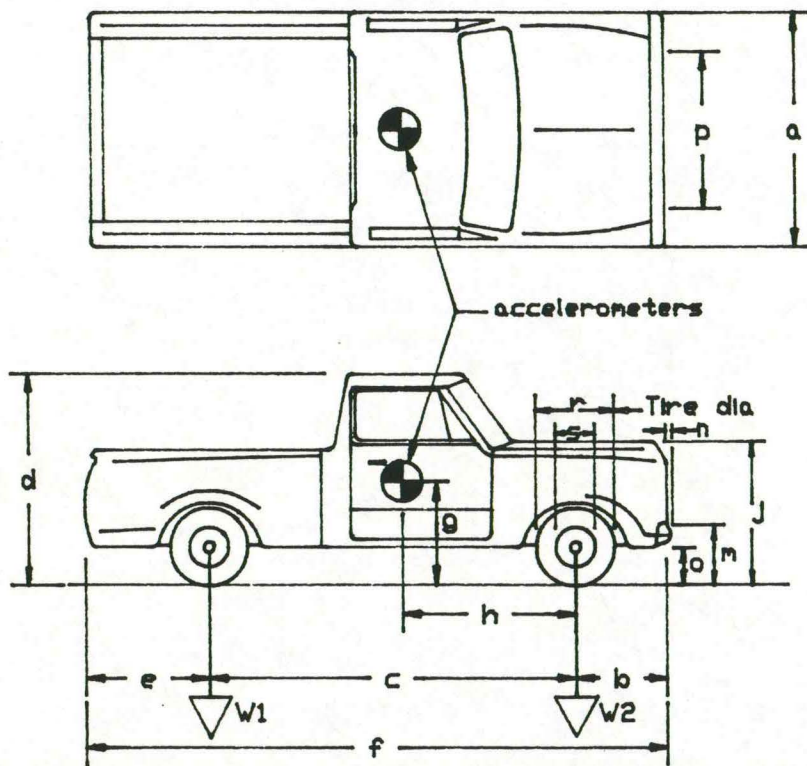

FIGURE 15. PHOTOGRAPHS OF TEST VEHICLE.

Date: 11/10/89 Test No: I6-1 Vehicle I.D. #: 1PTHF2512DPB12570  
 Make: Ford Model: F-250 Year: 1983 Odometer: 09412  
 Tire Size: 9.5R165LT



Vehicle Geometry - Inches

|   |              |   |              |
|---|--------------|---|--------------|
| a | <u>77.7</u>  | b | <u>29</u>    |
| c | <u>130</u>   | d | <u>70</u>    |
| e | <u>49.5</u>  | f | <u>208.5</u> |
| g | <u>26.75</u> | h | <u>54</u>    |
| i | <u>N/A</u>   | j | <u>45.75</u> |
| k | <u>N/A</u>   | l | <u>N/A</u>   |
| m | <u>26</u>    | n | <u>4</u>     |
| o | <u>19</u>    | p | <u>62</u>    |
| r | <u>29</u>    | s | <u>16</u>    |

Engine Type: V8 Diesel  
 Engine Size: 6.9 Liter

Transmission Type:  
 Automatic or Manual  
 FWD or  RWD or 4WD

4 - wheel weights: lf \_\_\_ rf \_\_\_ lr \_\_\_ rr \_\_\_

| Weight - pounds | Curb         | Test Inertial | Gross Static |
|-----------------|--------------|---------------|--------------|
| W1              | <u>2,870</u> | <u>3,170</u>  | <u>3,170</u> |
| W2              | <u>2,050</u> | <u>2,250</u>  | <u>2,250</u> |
| Wtotal          | <u>4,920</u> | <u>5,420</u>  | <u>5,420</u> |

Note any damage prior to test: None

FIGURE 16. VEHICLE MEASUREMENTS

Additional roof targets were placed ahead and behind the center of mass. The targets were used in the analysis of the high speed film. In addition to the roof targets, side and rear targets were also placed at known positions to aid in the evaluation process.

Two 5B flash-bulbs were mounted on the roof of the test vehicle to record the time of impact with the w-beam approach guardrail on the high-speed film. The flash bulbs were fired by a pressure tape switch mounted on the front face of the bumper.

## **2.4. Data Acquisition Systems**

### **2.4.1. Accelerometers**

Six Endevco triaxial piezoresistive accelerometers (Model 7264) with a range of  $\pm 200$  g's were used to measure the accelerations in the longitudinal, lateral, and vertical directions of the test vehicle. Two accelerometers were mounted in each of the three directions so that there would be two readings to compare. The accelerometers were rigidly attached to a metal block mounted at the center-of-mass. The signals from the accelerometers were received and conditioned by an onboard vehicle Metraplex Unit. The multiplexed signal was then radio transmitted to the Honeywell 101 Analog Tape Recorder in the central control van. A flow chart of the accelerometer data acquisition system is shown in Figure 17, and photographs of the system located in the centrally controlled step van are shown in Figure 18. State-of-the-art computer software, "Computerscope and DSP", was used to analyze and plot the accelerometer data on a Cyclone 386/AT, which uses a high-speed data acquisition board.

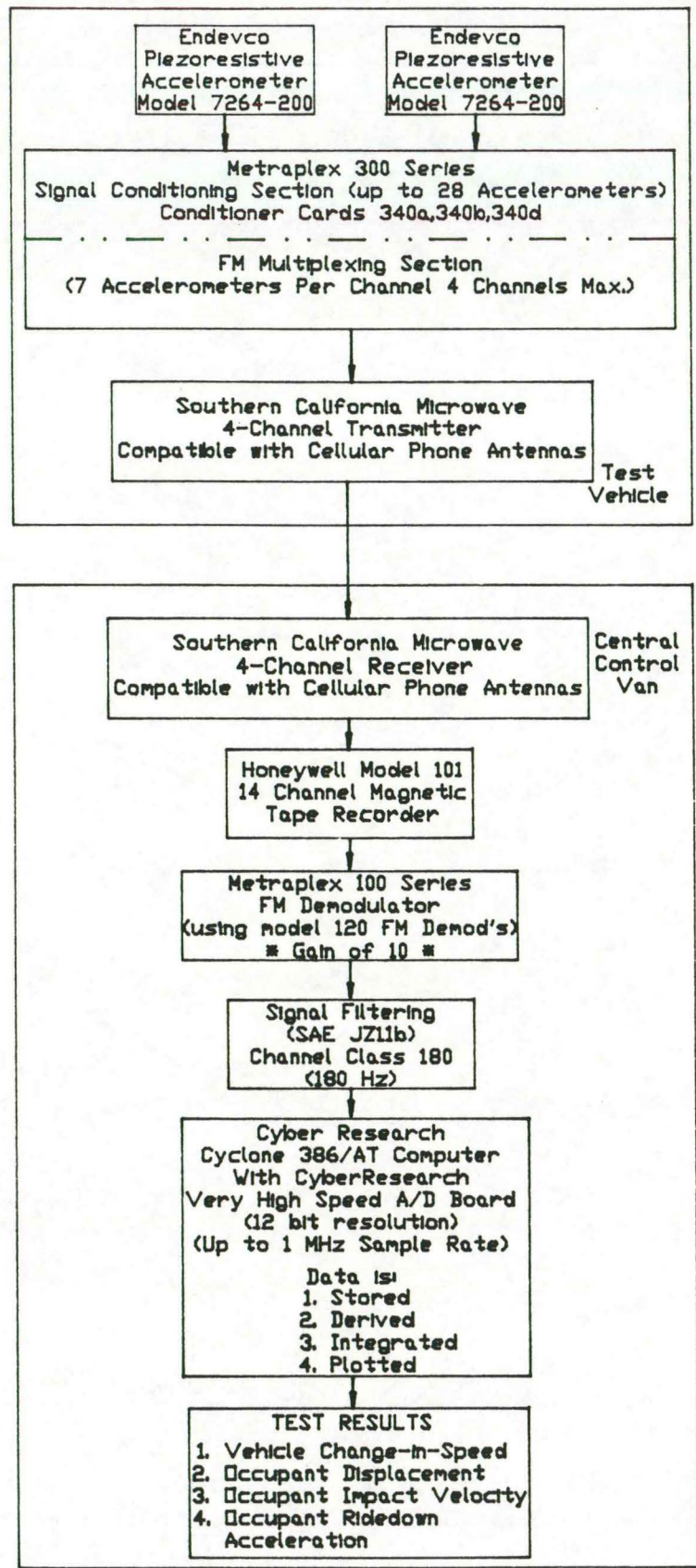

FIGURE 17.

FLOW CHART OF ACCELEROMETER DATA ACQUISITION SYSTEM



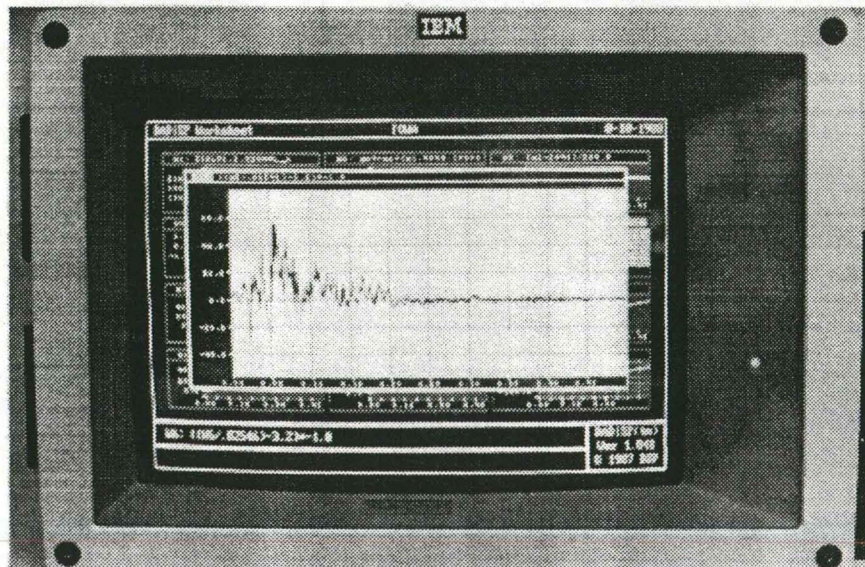
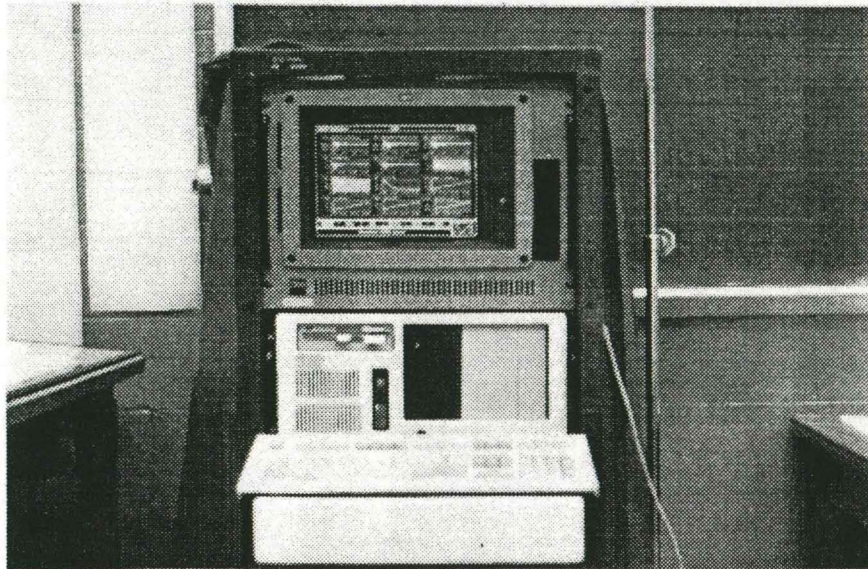
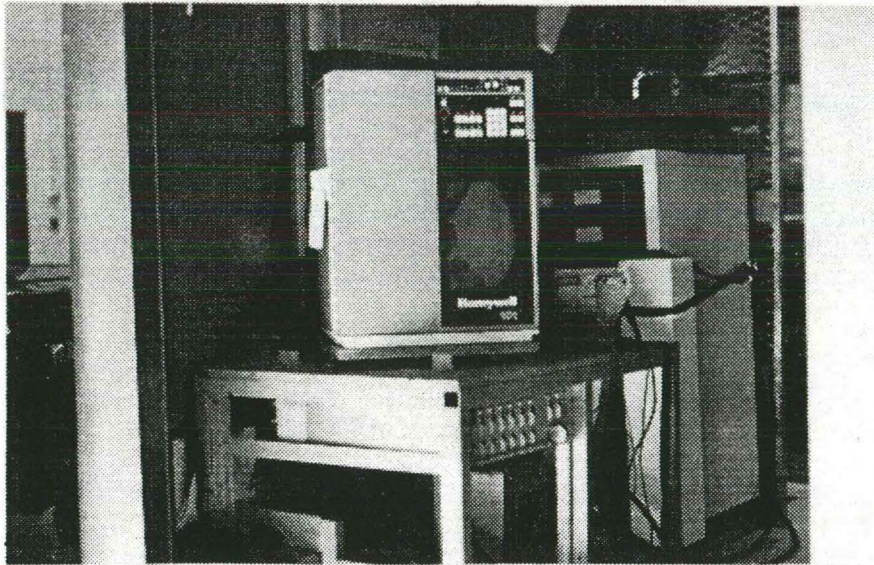

Figure 18. Photographs of data recorder and 386/AT computer.

#### **2.4.2. High-Speed Photography**

Three high-speed 16 mm cameras were used to film the crash tests. The cameras operated at approximately 500 frames/sec. The overhead camera was a Red Lake Locam with a wide angle 12.5 mm lens. It was placed approximately 65 ft. above the concrete apron. The parallel camera was a Photec IV with an 80 mm lens. It was placed 250 ft. downstream and offset 3.3 ft. from a line parallel to the barrier rail. The perpendicular camera was a Photec IV with a 55 mm lens. It was placed 165 ft. from the vehicle point of impact. A schematic of the camera locations is shown in Figure 19.

A 20 ft. wide by 100 ft. long grid layout, shown in Figure 20, was painted on the concrete slab surface parallel and perpendicular to the barrier. The white-colored grid was incremented with 5 ft. divisions in both directions to give a visible reference system which could be used in the analysis of the overhead high-speed film.

The film was analyzed using the Vanguard Motion Analyzer. The camera divergence correction factors were also taken into consideration in the analysis of the high-speed film.

#### **2.4.3. Speed Trap Switches**

Eight tape pressure switches spaced at 5 ft. intervals were used to determine the speed of the vehicle before and after impact. Each tape switch fired a blue 5B flash-bulb located near each switch on the concrete slab as the left front tire of the test vehicle passed over it. The average speed of the test vehicle between the tape switches was determined by knowing the distance between pressure switches, the calibrated camera speed, and the number of frames from the high-speed film between flashes. In addition, the average speed was determined from electronic timing mark data recorded on the oscilloscope software used with the 386/AT computer as the test vehicle passed over each tape switch.

FIGURE 19. LAYOUT OF HIGH-SPEED CAMERAS.

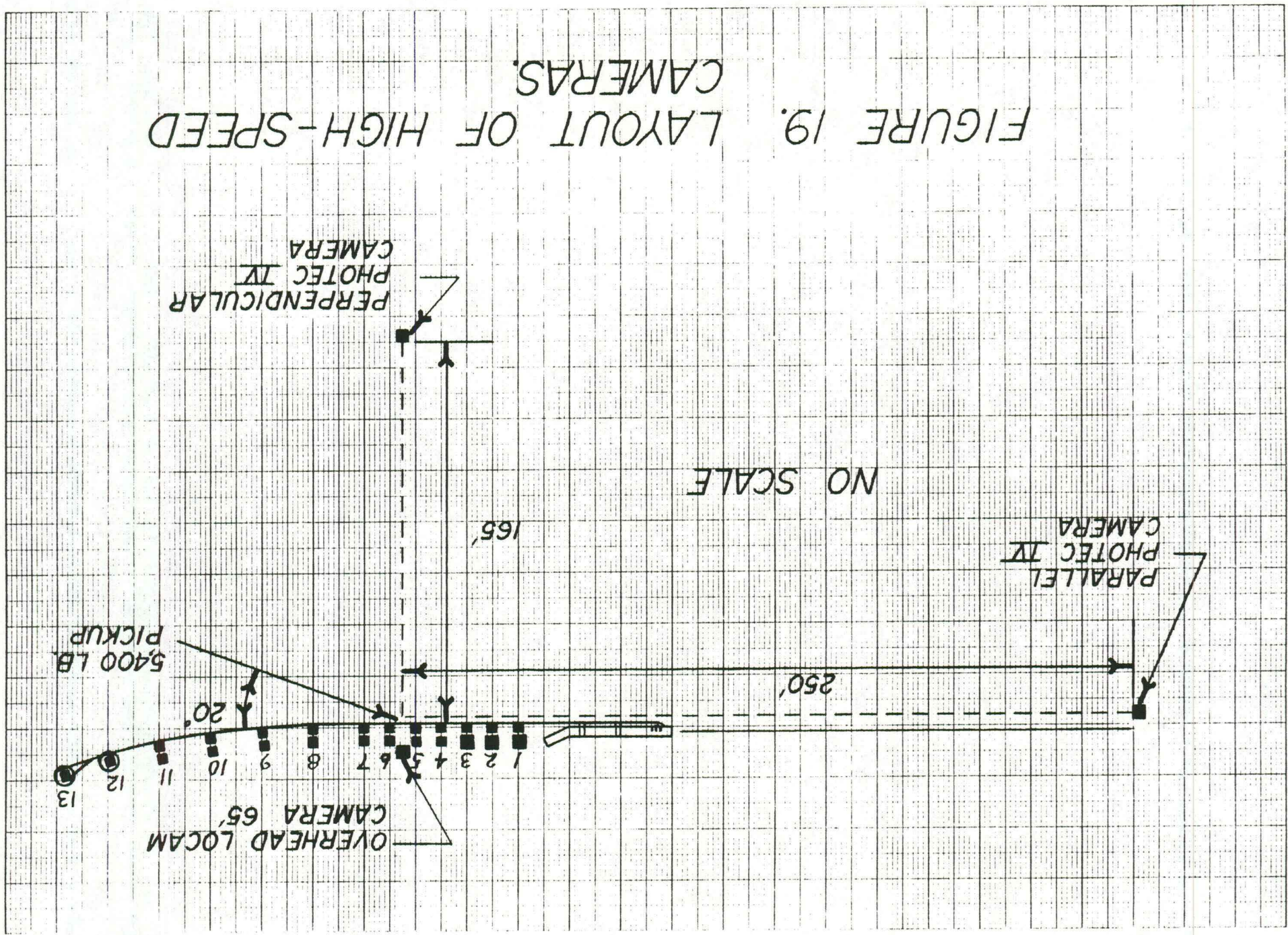

## **2.5. Test Parameters**

One full-scale vehicle crash test was conducted on the Iowa W-Beam Approach Guardrail Transition Section, as shown in Figures 4 through 14.

Test I6-1 was conducted at a target impact speed of 60 mph with an impact angle of 20 degrees. A 1983 Ford F-250 pickup weighing 5,420 lbs. was used as the crash test vehicle. The location of impact was 15 ft. upstream from the end of the concrete end-section between posts 5 and 6.

### 3. PERFORMANCE EVALUATION CRITERIA

The safety performance objective of a highway appurtenance is to minimize the consequences of a vehicle leaving the roadway to create an off-road incident. The safety goal is met when the appurtenance W-Beam Approach Guardrail Transition Section smoothly redirects the vehicle away from a hazard zone without subjecting the vehicle occupants to major injury producing forces.

Safety performance of a highway appurtenance cannot be measured directly, but it can be evaluated according to three major factors: (1) structural adequacy, (2) occupant risk, and (3) vehicle trajectory after collision. These three factors are defined and explained in NCHRP 230 (1). Similar criteria are presented in the new AASHTO criteria (2).

The test conditions for the matrix are shown in Table 1, and stated in Appendix B. Also, the specific evaluation criteria used to determine the adequacy of the barrier are listed and will be explained later in Tables 2 and 3.

After each test, the vehicle damage was assessed by the traffic accident scale (TAD) (4) and the vehicle damage index (VDI) (5).

**TABLE 1. CRASH TEST CONDITIONS AND EVALUATION CRITERIA FOR THE  
IOWA APPROACH GUARDRAIL TRANSITION SECTION**

| Test Agency   | Test Designation | Performance Level | Appurtenance | Test Vehicle       | Impact Conditions |             |                                    | Evaluation Criteria <sup>a</sup> |              |
|---------------|------------------|-------------------|--------------|--------------------|-------------------|-------------|------------------------------------|----------------------------------|--------------|
|               |                  |                   |              |                    | Speed (mph)       | Angle (deg) | Location                           | Required                         | Desirable    |
| NCHRP 230 (1) | 30               | -                 | Transition   | 4,500 lb. (sedan)  | 60                | 25          | 15 ft. upstream from second system | A,D,E, H,I                       | -            |
| AASHTO        | -                | PL-2              | Bridge       | 5,400 lb. (pickup) | 60                | 20          | see NCHRP 230 (1)                  | 3. a, b, c, d                    | 3. e, f g, h |

Notes:

<sup>a</sup> Criteria described in Tables 2 and 3.

**TABLE 2. NCHRP 230 EVALUATION CRITERIA**

|                     |  |
|---------------------|--|
| Structural Adequacy | <p>A: Test article shall smoothly redirect the vehicle; the vehicle shall not penetrate or go over the installation although controlled lateral deflection of the test article is acceptable.</p>  |
|                     | <p>D. Detached elements, fragments or other debris from the test article shall not penetrate or show potential for penetrating the passenger compartment or present undue hazard to other traffic.</p>   |
| Occupant Risk       | <p>E. The vehicle shall remain upright during and after collision although moderate roll, pitching, and yawing are acceptable. Integrity of the passenger compartment must be maintained with essentially no deformation or intrusion.</p>   |
| Vehicle Trajectory  | <p>H. After collision, vehicle trajectory and final stopping position shall intrude a minimum distance, if at all, into adjacent traffic lanes.</p>  |
|                     | <p>I. In test where the vehicle is judged to be redirected into or stopped while in adjacent traffic lanes, vehicle speed change during test article collision should be less than 15 mph and the exit angle from the test article should be less than 60 percent of test impact angle, both measured at time of vehicle loss of contact with test device.</p> |

**TABLE 3. AASHTO EVALUATION CRITERIA**

| a.   | The test article shall contain the vehicle; neither the vehicle nor its cargo shall penetrate or go over the installation. Controlled lateral deflection of the test article is acceptable.  |                                       |                   |                     |                |             |      |  |          |                     |                |    |    |
|--|--|---------------------------------------|-------------------|---------------------|----------------|-------------|------|--|----------|---------------------|----------------|----|----|
| b.   | Detached elements, fragments, or other debris from the test article shall not penetrate or show potential for penetrating the passenger compartment or present undue hazard to other traffic.  |                                       |                   |                     |                |             |      |  |          |                     |                |    |    |
| c.   | Integrity of the passenger compartment must be maintained with no intrusion and essentially no deformation.  |                                       |                   |                     |                |             |      |  |          |                     |                |    |    |
| d.   | The vehicle shall remain upright during and after collision.   |                                       |                   |                     |                |             |      |  |          |                     |                |    |    |
| e.   | The test article shall smoothly redirect the vehicle. A redirection is deemed smooth if the rear of the vehicle does not yaw more than 5 degrees away from the railing from time of impact until the vehicle separates from the railing.   |                                       |                   |                     |                |             |      |  |          |                     |                |    |    |
| f.   | The smoothness of the vehicle-railing interaction is further assessed by the effective coefficient of friction $\mu$ , where $\mu = (\cos\theta - V_p/V)/\sin\theta$ . <table style="margin-left: auto; margin-right: auto;"> <thead> <tr> <th style="text-align: center;"><u><math>\mu</math></u></th> <th style="text-align: center;"><u>Assessment</u></th> </tr> </thead> <tbody> <tr> <td style="text-align: center;">0.0 - 0.25</td> <td style="text-align: center;">Good</td> </tr> <tr> <td style="text-align: center;">0.26 - 0.35</td> <td style="text-align: center;">Fair</td> </tr> <tr> <td style="text-align: center;">&gt; 0.35</td> <td style="text-align: center;">Marginal</td> </tr> </tbody> </table>   | <u><math>\mu</math></u>               | <u>Assessment</u> | 0.0 - 0.25          | Good           | 0.26 - 0.35 | Fair | > 0.35                                       | Marginal |                     |                |    |    |
| <u><math>\mu</math></u>                      | <u>Assessment</u>  |                                       |                   |                     |                |             |      |  |          |                     |                |    |    |
| 0.0 - 0.25                                   | Good   |                                       |                   |                     |                |             |      |  |          |                     |                |    |    |
| 0.26 - 0.35                                  | Fair   |                                       |                   |                     |                |             |      |  |          |                     |                |    |    |
| > 0.35                                       | Marginal   |                                       |                   |                     |                |             |      |  |          |                     |                |    |    |
| g.   | The impact velocity of a hypothetical front-seat passenger against the vehicle interior, calculated from vehicle accelerations and 2.0 ft. longitudinal and 1.0 ft. lateral displacements, shall be less than: <table style="margin-left: auto; margin-right: auto;"> <thead> <tr> <th colspan="2" style="text-align: center;"><u>Occupant Impact Velocity - fps</u></th> </tr> <tr> <th style="text-align: center;"><u>Longitudinal</u></th> <th style="text-align: center;"><u>Lateral</u></th> </tr> </thead> <tbody> <tr> <td style="text-align: center;">30</td> <td style="text-align: center;">25</td> </tr> </tbody> </table> <p>and for the vehicle highest 10-ms average accelerations subsequent to the instant of hypothetical passenger impact should be less than:</p> <table style="margin-left: auto; margin-right: auto;"> <thead> <tr> <th colspan="2" style="text-align: center;"><u>Occupant Ridedown Accelerations - g's</u></th> </tr> <tr> <th style="text-align: center;"><u>Longitudinal</u></th> <th style="text-align: center;"><u>Lateral</u></th> </tr> </thead> <tbody> <tr> <td style="text-align: center;">15</td> <td style="text-align: center;">15</td> </tr> </tbody> </table> | <u>Occupant Impact Velocity - fps</u> |                   | <u>Longitudinal</u> | <u>Lateral</u> | 30          | 25   | <u>Occupant Ridedown Accelerations - g's</u> |          | <u>Longitudinal</u> | <u>Lateral</u> | 15 | 15 |
| <u>Occupant Impact Velocity - fps</u>        |  |                                       |                   |                     |                |             |      |  |          |                     |                |    |    |
| <u>Longitudinal</u>                          | <u>Lateral</u>   |                                       |                   |                     |                |             |      |  |          |                     |                |    |    |
| 30   | 25   |                                       |                   |                     |                |             |      |  |          |                     |                |    |    |
| <u>Occupant Ridedown Accelerations - g's</u> |  |                                       |                   |                     |                |             |      |  |          |                     |                |    |    |
| <u>Longitudinal</u>                          | <u>Lateral</u>   |                                       |                   |                     |                |             |      |  |          |                     |                |    |    |
| 15   | 15   |                                       |                   |                     |                |             |      |  |          |                     |                |    |    |
| h.   | Vehicle exit angle from the barrier shall not be more than 12 degrees. Within 100 ft. plus the length of the test vehicle from the point of initial impact with the railing, the railing side of the vehicle shall move no more than 20 ft. from the line of the traffic face of the railing.  |                                       |                   |                     |                |             |      |  |          |                     |                |    |    |



## 4. TEST RESULTS

### 4.1. Test No. I6-1

Test I6-1 was conducted with a 5,420 lb. Ford F-250 pickup under the impact conditions of 61.45 mph and 20.0 degrees. The location of impact was 15 ft. upstream from the end of the concrete end-section. A summary of the test results is shown in Figure 20. The sequential photographs are shown in Figures 21 (a), (b), and (c).

Upon impact with the w-beam approach guardrail, the right front corner of the vehicle began to crush inward. At approximately 0.025 sec., the vehicle was between posts 5 and 4. At 0.040 sec., the right front corner of the vehicle was over post 4. The right front corner of the vehicle was over post 3, 2, and 1 at approximately 0.076, 0.110, and 0.144 sec., respectively. The vehicle began to show an uplifting motion due to the presence of the curb at approximately 0.126 sec.

The vehicle came into contact with the concrete end-section at approximately 0.159 sec. At 0.172 sec., the front end of the vehicle began to leave the ground surface. The vehicle was parallel to the installation at approximately 0.273 sec., with a parallel velocity of 42.74 mph. At approximately 0.305 sec., the vehicle began to exit the installation at 41.72 mph and 2.8 degrees.

The vehicle was airborne after being redirected at approximately 0.350 sec. At about 0.521 sec., the vehicle began to fall back toward the ground. At approximately 0.807 sec., the vehicle impacted the concrete apron surface.

Photographs of the vehicle damage are shown in Figure 22. As evident, the vehicle damage was marginal. The TAD and VDI damage classifications are shown in Figure 20.

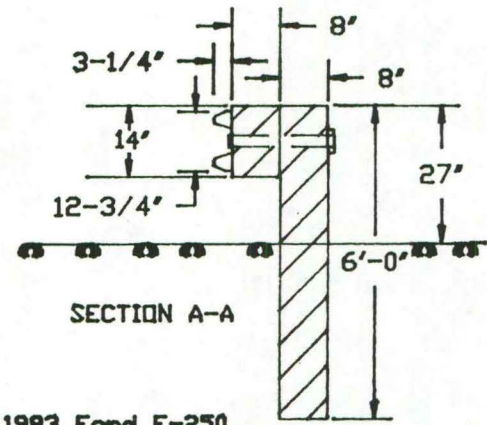
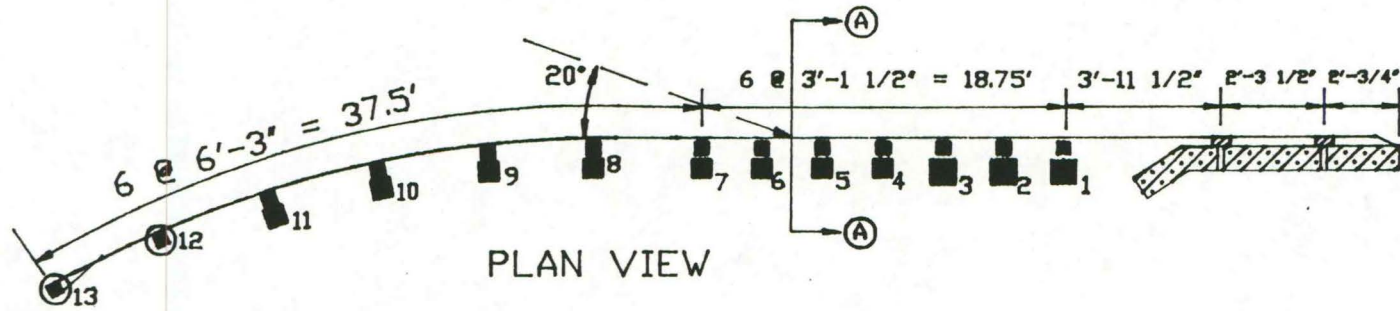
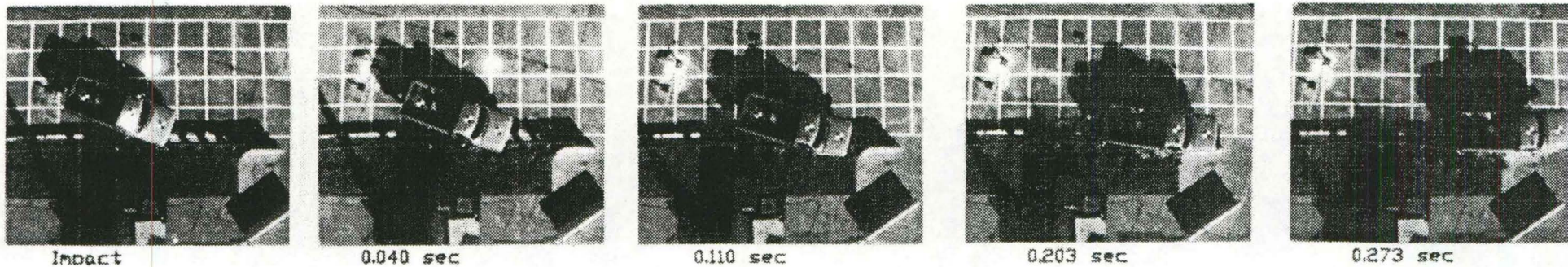

33

|   |  |
|---|--|
| ● Test No. . . . .                              | I6-1   |
| ● Date . . . . .                                | 11/10/89   |
| ● Installation . . . . .                        | Iowa W-Beam Approach<br>Guardrail To The Concrete<br>Safety Shape Bridge Rail<br>BRF-000S(12)--38-00 |
| Drawing No. . . . .                             | BRF-000S(12)--38-00  |
| Length . . . . .                                | 64'-6 3/4"   |
| ● Concrete Bridge Rail End . . . . .            | Concrete Safety Shape<br>Barrier Rail  |
| Length . . . . .                                | 7'-0"  |
| Height . . . . .                                | 2'-8"  |
| ● Guardrail Beam Member . . . . .               | Standard W-Beam  |
| Size . . . . .                                  | 12 Gauge   |
| Length . . . . .                                | 62'-6"   |
| ● Guardrail W-Beam Terminal Connector . . . . . | 10 Gauge (Type F)  |
| Length . . . . .                                | 2'-6"  |
| ● Guardrail Breakaway End Anchorage . . . . .   | 10 Gauge (Type E)  |
| ● Guardrail Posts . . . . .                     | Timber   |
| Size  |  |
| Post No. 1 thru 3 . . . . .                     | 10' X 10' X 72"  |
| Post No. 4 thru 11 . . . . .                    | 8' X 8' X 72"  |
| Post No. 12 and 13 . . . . .                    | 6' X 8' X 72"  |
| ● Concrete Curb Section                         |  |
| Width   |  |
| Top . . . . .                                   | 4 1/2"   |
| Bottom . . . . .                                | 7 1/2"   |
| Height . . . . .                                | 6"   |
| ● Soil Conditions . . . . .                     | Dry  |
| Type  |  |
| Lower Layer . . . . .                           | Special Backfill   |
| Upper Layer . . . . .                           | Earth Fill   |

|                                      |                           |
|--------------------------------------|---------------------------|
| ● Vehicle                            |                           |
| Model . . . . .                      | 1983 Ford F-250<br>Pickup |
| Weight                               |                           |
| Test Inertia . . . . .               | 5,420 lbs.                |
| Gross Static . . . . .               | 5,420 lbs.                |
| ● Vehicle Speed                      |                           |
| Impact . . . . .                     | 61.45 mph                 |
| Exit . . . . .                       | 41.72 mph                 |
| ● Vehicle Angle                      |                           |
| Impact . . . . .                     | 20.0 degrees              |
| Exit . . . . .                       | 2.8 degrees               |
| ● Vehicle Snagging . . . . .         | Marginal                  |
| ● Vehicle Stability . . . . .        | Marginal                  |
| ● Occupant Impact Velocity           |                           |
| Longitudinal . . . . .               | 21.6 fps                  |
| Lateral . . . . .                    | 17.1 fps                  |
| ● Occupant Ridedown Deceleration     |                           |
| Longitudinal . . . . .               | 8.5 g's                   |
| Lateral . . . . .                    | 8.9 g's                   |
| ● Vehicle Damage . . . . .           | Marginal                  |
| TAD . . . . .                        | 1-RFQ-4                   |
| VDI . . . . .                        | 01RFEK2                   |
| ● Vehicle Rebound Distance . . . . . | 9'-7" @ 118'              |
| ● Guardrail Damage . . . . .         | Marginal                  |
| ● Maximum Guardrail Deflections      |                           |
| Permanent Set . . . . .              | 12.4 in.                  |
| Dynamic . . . . .                    | 20.4 in.                  |

FIGURE 20. TEST I6-1 SUMMARY AND SEQUENTIAL PHOTOGRAPHS

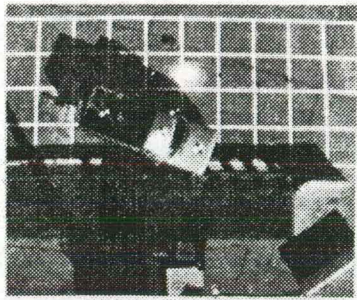

0.000 sec

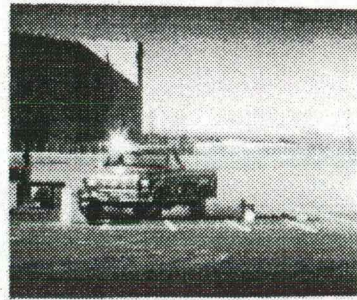

0.025 sec

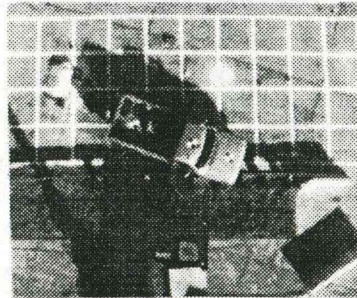
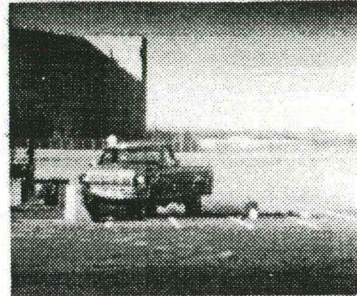

0.040 sec

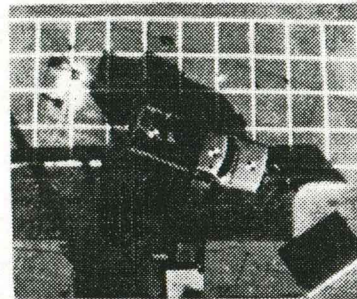

0.076 sec

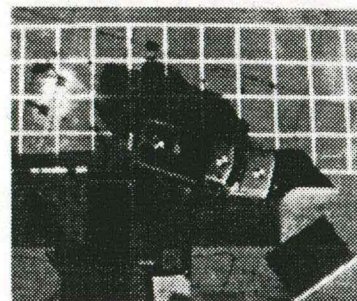
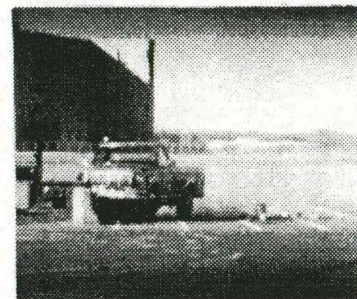

0.110 sec

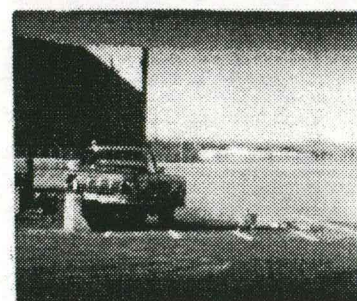
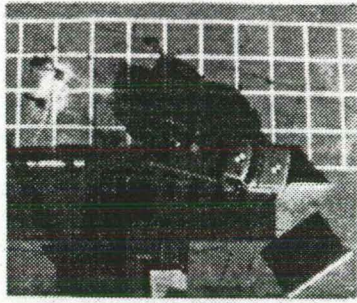
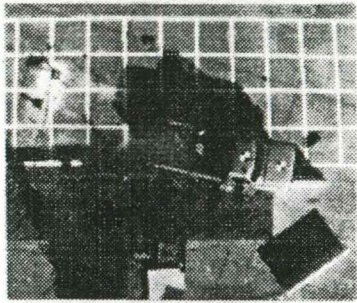

FIGURE 21(a). TIME-SEQUENTIAL PHOTOGRAPHS.



0.144 sec



0.159 sec

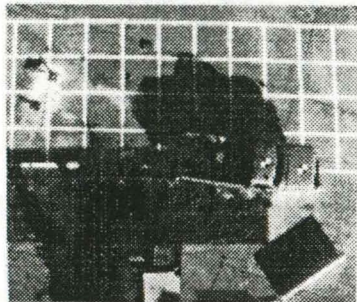
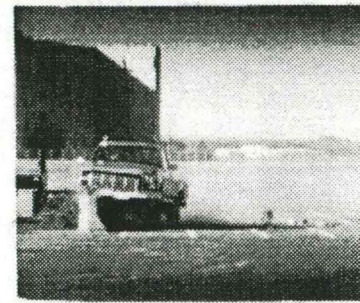

0.203 sec

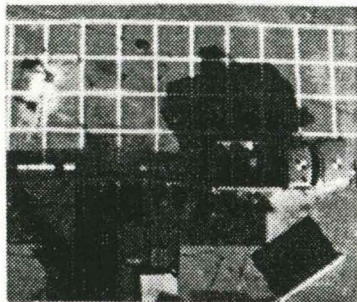
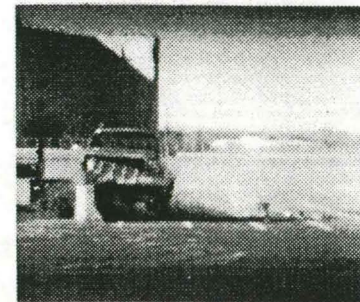

0.273 sec

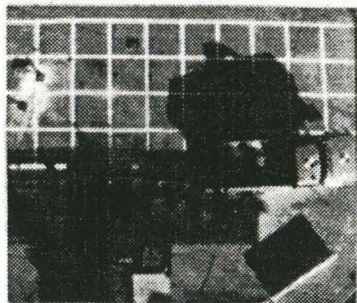
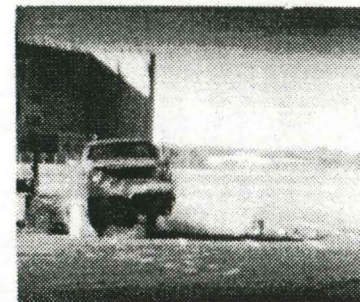

0.305 sec

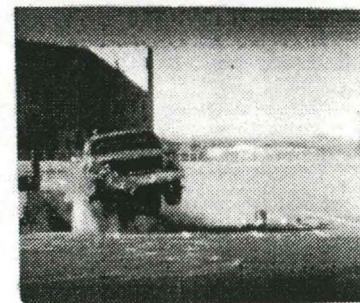
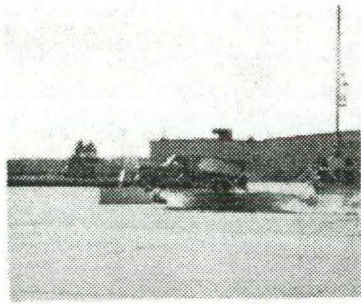
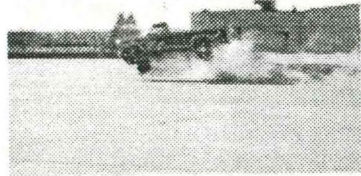

FIGURE 21(b). TIME-SEQUENTIAL PHOTOGRAPHS.



0.350 sec



0.521 sec



0.807 sec



1.001 sec

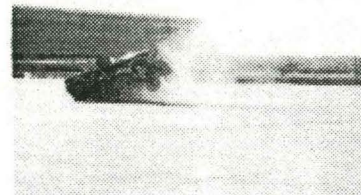

1.402 sec



FIGURE 21(c). TIME-SEQUENTIAL PHOTOGRAPHS.

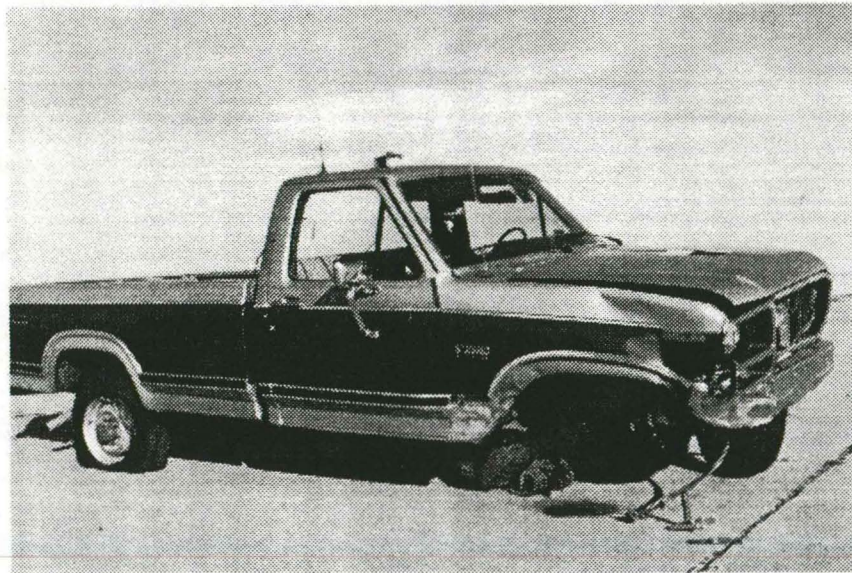
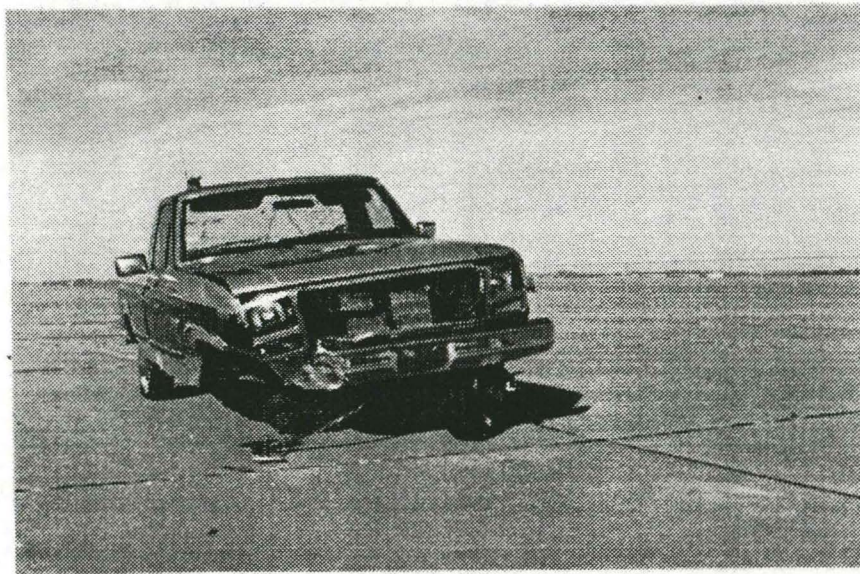
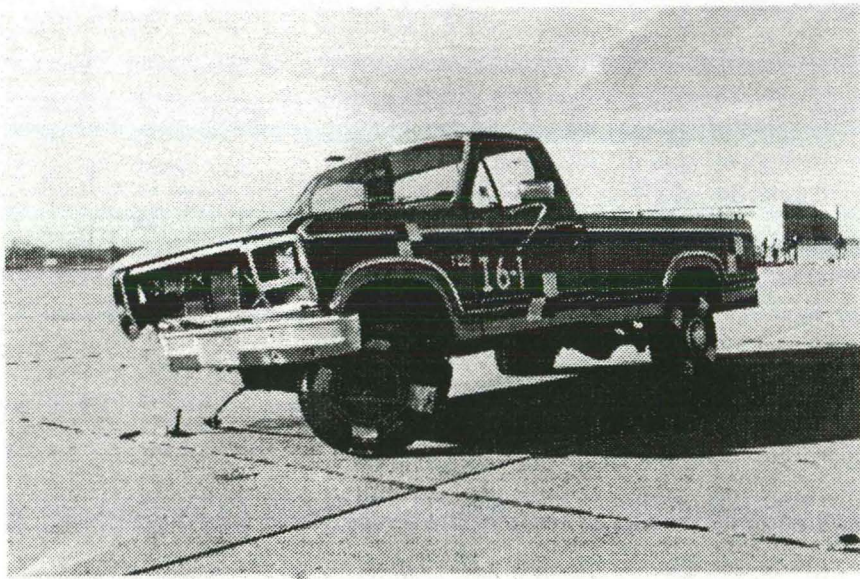

FIGURE 22. PHOTOGRAPHS OF VEHICLE DAMAGE.

Photographs of the marginal damage to the approach guardrail transition section are shown in Figures 23 through 26. After viewing the damaged guardrail, there was evidence that slight snagging occurred at post 1 and minor concrete spalling at the top of the concrete end-section.

After the test, the permanent set was measured and is shown in Figure 27. The maximum permanent set was 12.4-in. which occurred at post 2. The maximum lateral dynamic deflection was 20.4-in., as determined from the overhead high-speed camera.

Graphs of longitudinal and lateral deceleration, vehicle change in speed, lateral occupant impact velocity, and longitudinal and lateral occupant displacement versus time are given in Appendix C.

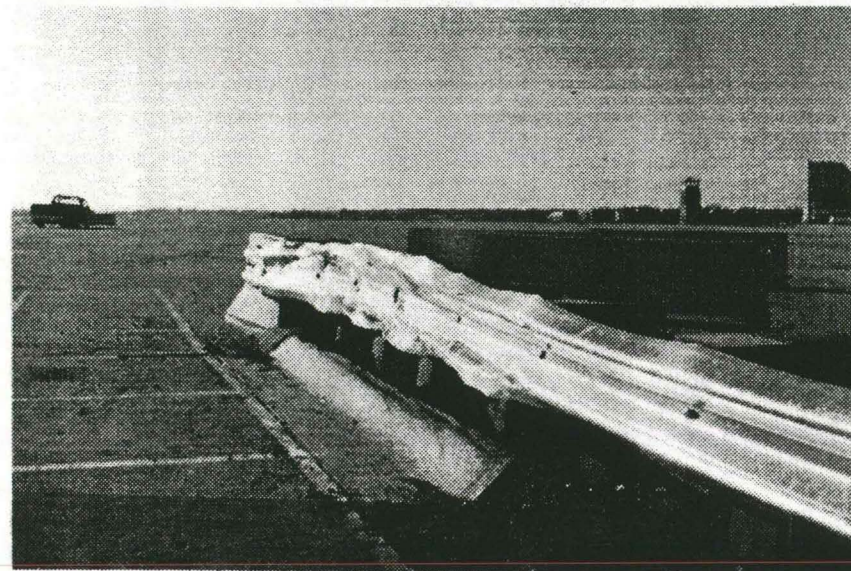
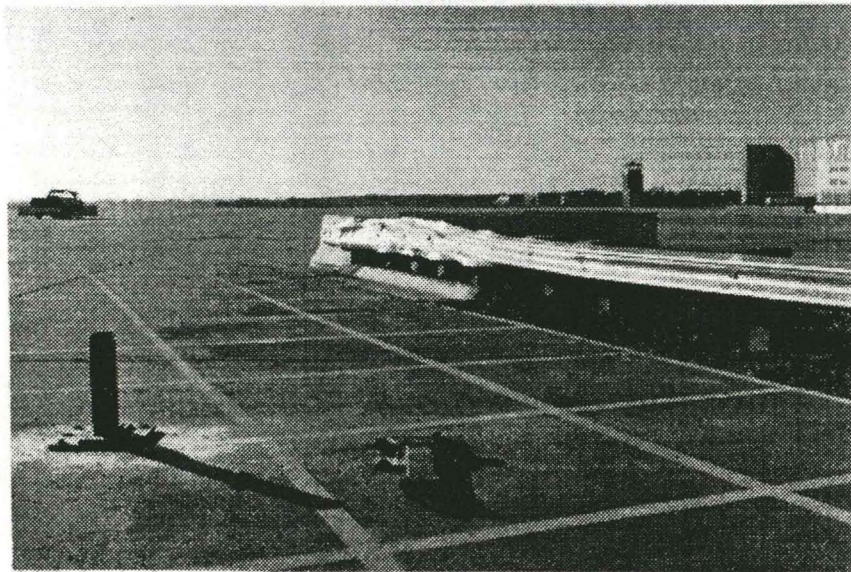
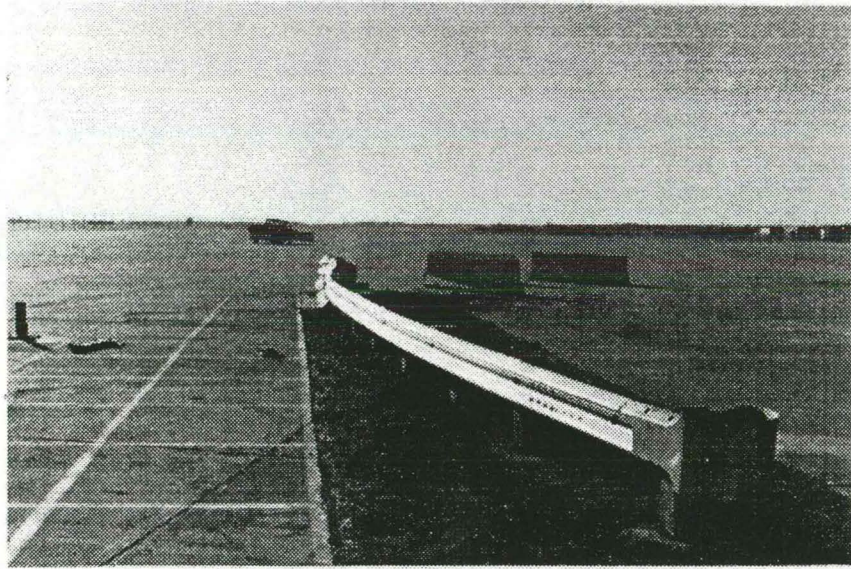

FIGURE 23. PHOTOGRAPHS OF DAMAGE TO APPROACH GUARDRAIL TRANSITION SECTION.



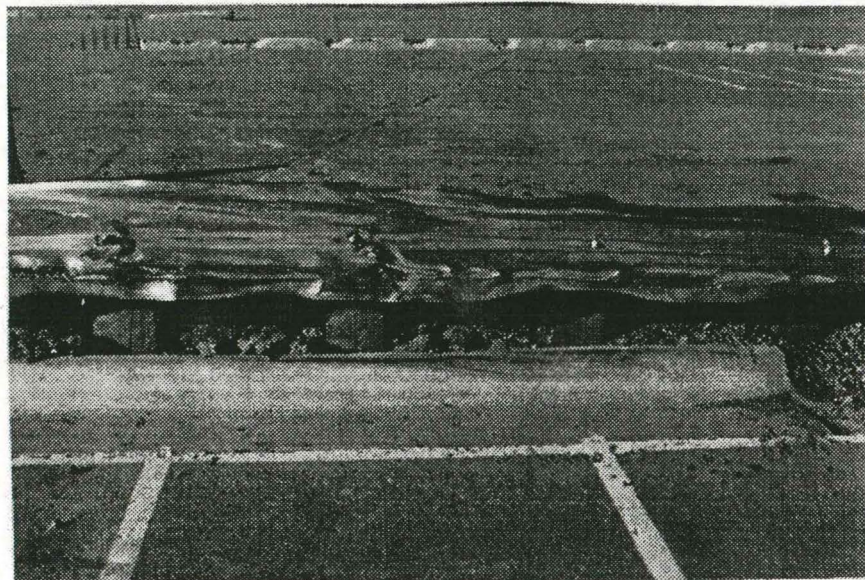
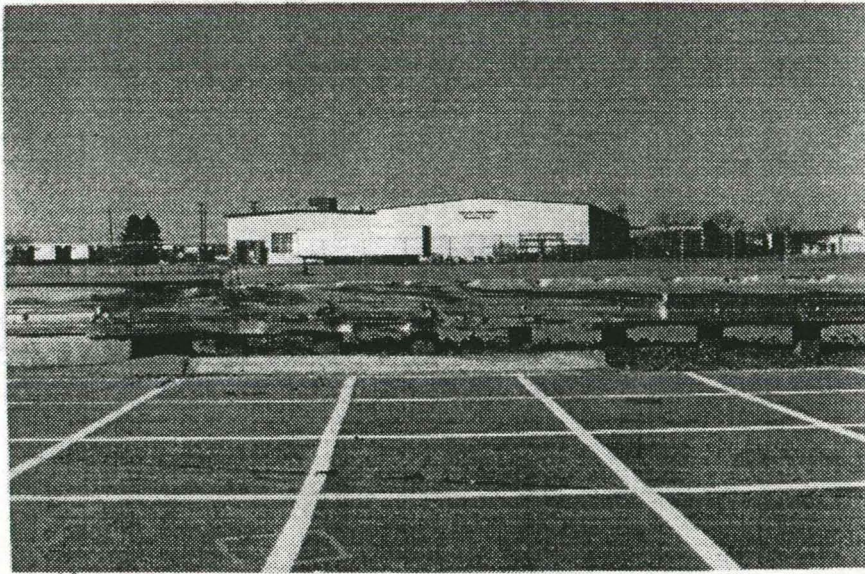

FIGURE 24. PHOTOGRAPHS OF DAMAGE TO APPROACH GUARDRAIL TRANSITION SECTION.

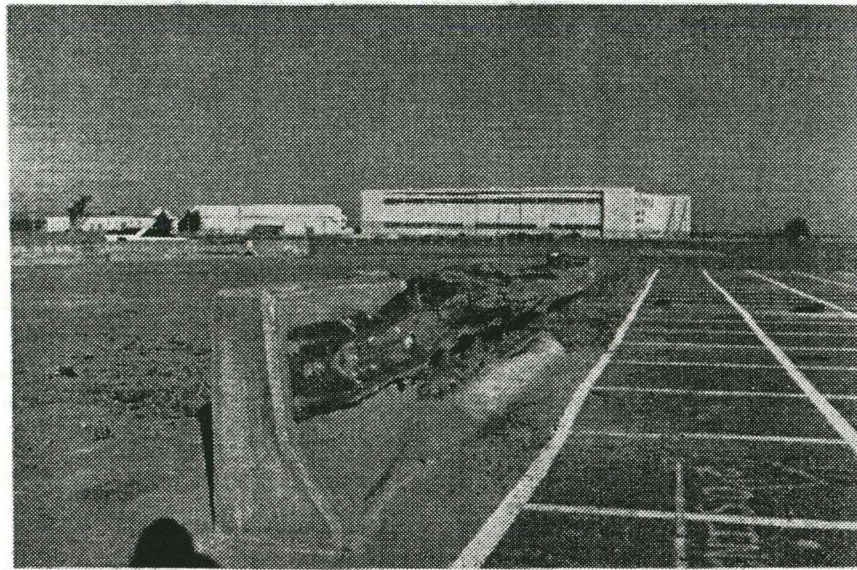
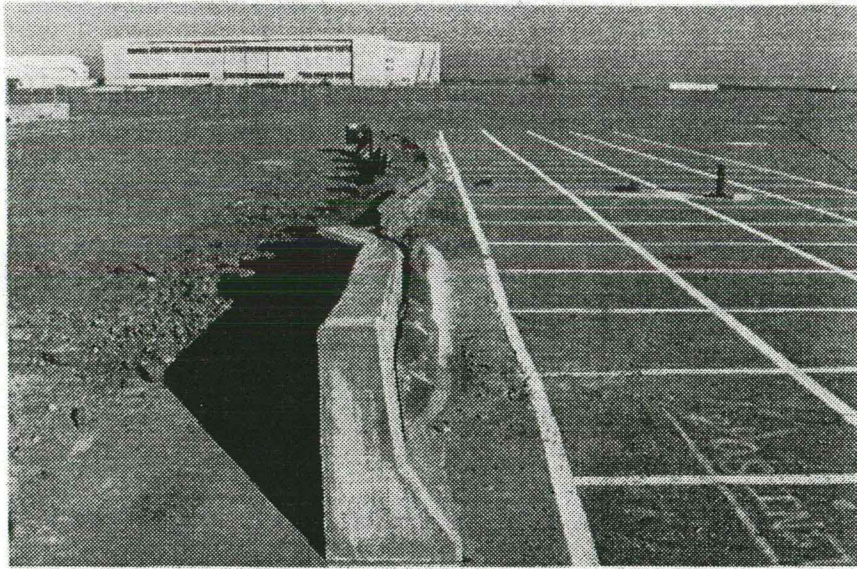

FIGURE 25. PHOTOGRAPHS OF DAMAGE TO APPROACH GUARDRAIL TRANSITION SECTION.

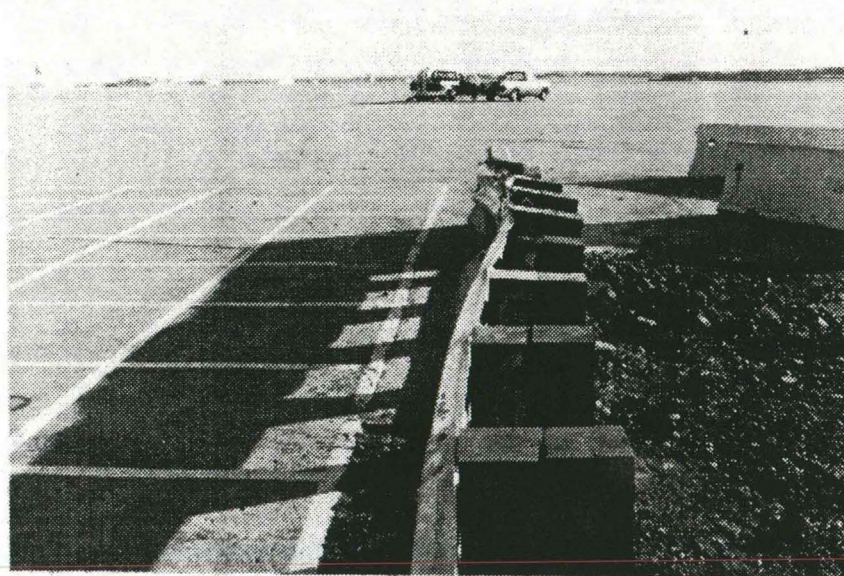
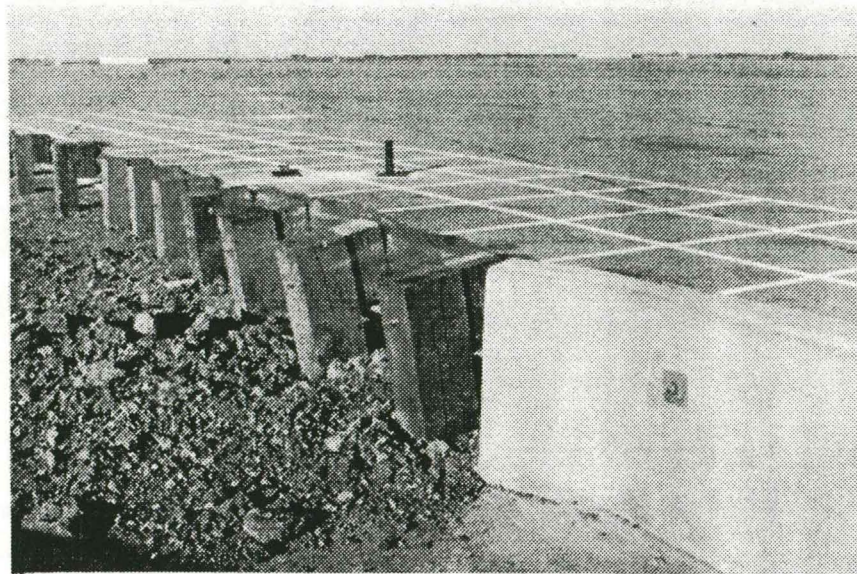
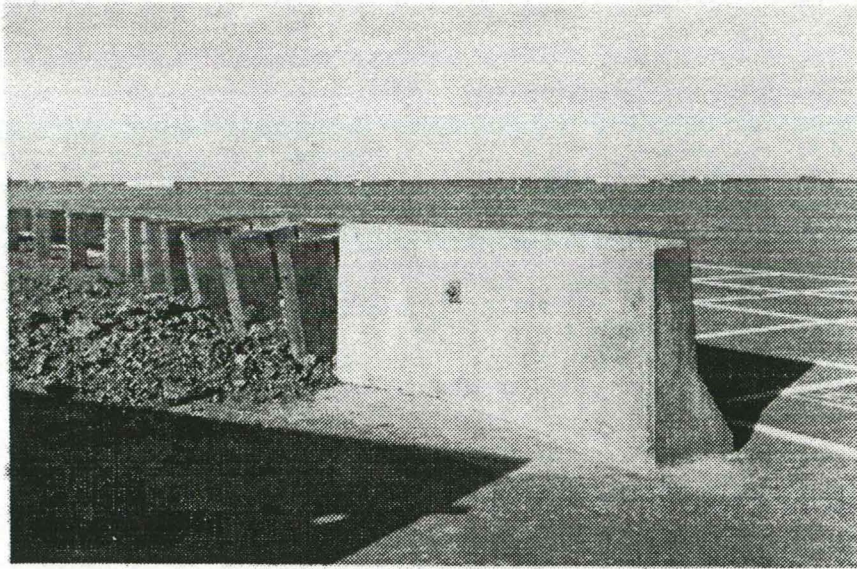
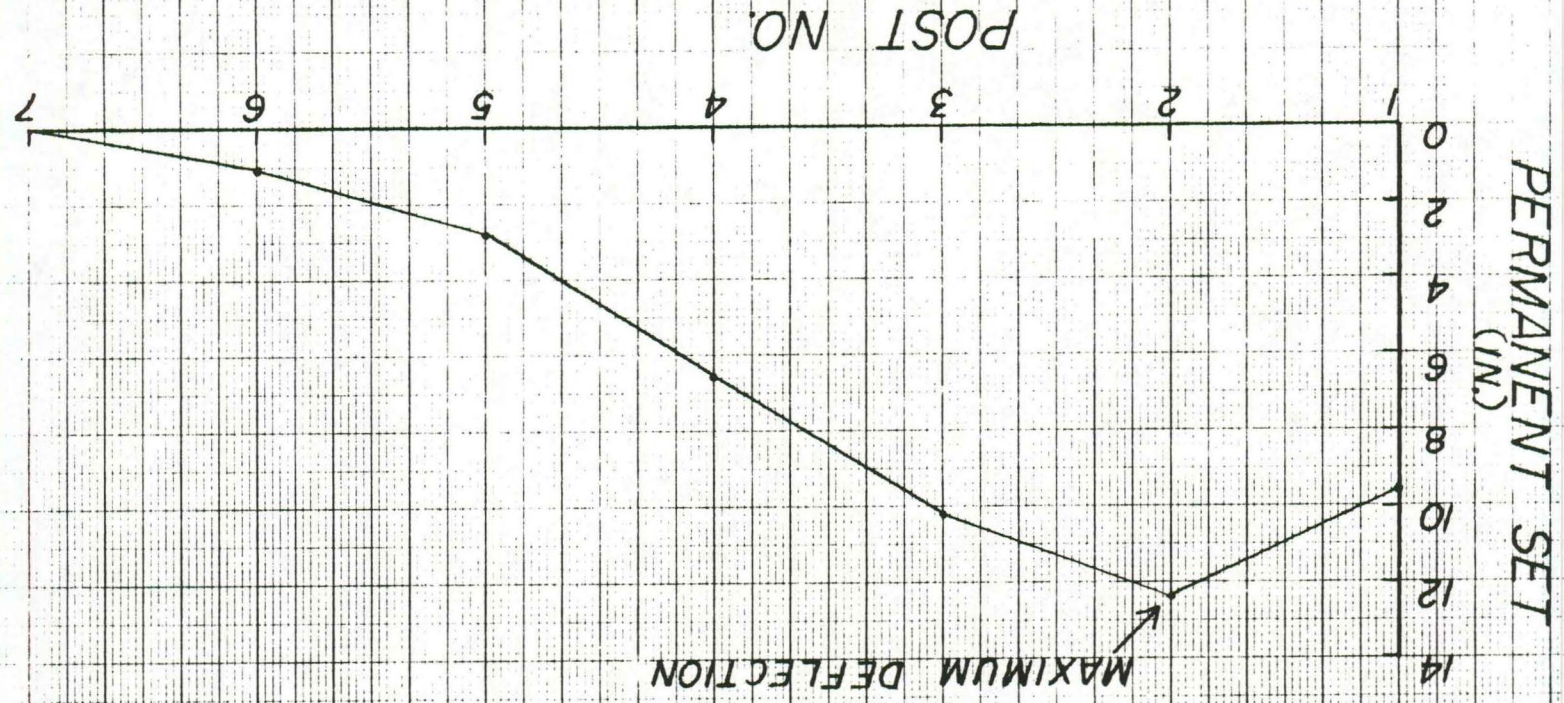
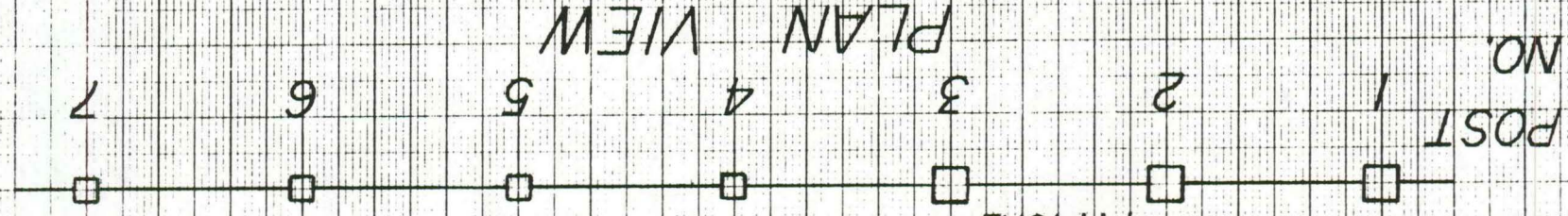

FIGURE 26. PHOTOGRAPHS OF DAMAGE TO APPROACH GUARDRAIL TRANSITION SECTION.

FIGURE 27 GRAPH OF PERMANENT SET DISPLACEMENTS



## 5. CONCLUSIONS

One full-scale crash test was conducted to evaluate the safety performance of the Iowa W-Beam Approach Guardrail Transition Section.

Test I6-1 was evaluated according to the safety performance criteria given in NCHRP 230 (1) and AASHTO (2). The safety evaluation summaries using both sets of criteria are presented in Tables 4 and 5.

The analysis of the crash test revealed the following:

1. The Iowa W-Beam Approach Guardrail contained the test vehicle.
2. The test vehicle did not penetrate or ride over the installation.
3. The controlled lateral deflection of the test article was acceptable.
4. There were no detached elements or fragments from the test article which showed potential for undue hazard during and after the collision.
5. The integrity of the passenger compartment was maintained.
6. The test vehicle remained upright during and after the collision; although, the test vehicle was vaulted into the air due to the uplifting motion of the curb.
7. The occupant risk values for impact velocity and ridedown decelerations were acceptable during impact.
8. The test vehicle's change in speed was marginal (19.73 mph > 15 mph). The speed change is a trajectory hazard factor only when the redirection barrier is very near the traffic stream or when the vehicle is redirected abruptly back into the traffic stream.

**TABLE 4. NCHRP 230 EVALUATION CRITERIA**

|                     |   |   |
|---------------------|---|---|
| Structural Adequacy | A: Test article shall smoothly redirect the vehicle; the vehicle shall not penetrate or go over the installation although controlled lateral deflection of the test article is acceptable.  | S |
|                     | D. Detached elements, fragments or other debris from the test article shall not penetrate or show potential for penetrating the passenger compartment or present undue hazard to other traffic.   | S |
| Occupant Risk       | E. The vehicle shall remain upright during and after collision although moderate roll, pitching, and yawing are acceptable. Integrity of the passenger compartment must be maintained with essentially no deformation or intrusion.   | S |
| Vehicle Trajectory  | H. After collision, vehicle trajectory and final stopping position shall intrude a minimum distance, if at all, into adjacent traffic lanes.  | S |
|                     | I. In test where the vehicle is judged to be redirected into or stopped while in adjacent traffic lanes, vehicle speed change during test article collision should be less than 15 mph and the exit angle from the test article should be less than 60 percent of test impact angle, both measured at time of vehicle loss of contact with test device. | S |

S - Satisfactory  
M - Marginal  
U - Unsatisfactory

TABLE 5. AASHTO EVALUATION CRITERIA

| A R E A                                      |  | Required                              | Desirable         |                     |                |             |      |  |          |                     |                    |    |    |  |   |
|--|--|---------------------------------------|-------------------|---------------------|----------------|-------------|------|--|----------|---------------------|--------------------|----|----|--|---|
| a.   | The test article shall contain the vehicle; neither the vehicle nor its cargo shall penetrate or go over the installation. Controlled lateral deflection of the test article is acceptable.  | S                                     |                   |                     |                |             |      |  |          |                     |                    |    |    |  |   |
| b.   | Detached elements, fragments, or other debris from the test article shall not penetrate or show potential for penetrating the passenger compartment or present undue hazard to other traffic.  | S                                     |                   |                     |                |             |      |  |          |                     |                    |    |    |  |   |
| c.   | Integrity of the passenger compartment must be maintained with no intrusion and essentially no deformation.  | S                                     |                   |                     |                |             |      |  |          |                     |                    |    |    |  |   |
| d.   | The vehicle shall remain upright during and after collision.   | M                                     |                   |                     |                |             |      |  |          |                     |                    |    |    |  |   |
| e.   | The test article shall smoothly redirect the vehicle. A redirection is deemed smooth if the rear of the vehicle does not yaw more than 5 degrees away from the railing from time of impact until the vehicle separates from the railing.   |                                       | S                 |                     |                |             |      |  |          |                     |                    |    |    |  |   |
| f.   | The smoothness of the vehicle-railing interaction is further assessed by the effective coefficient of friction $\mu$ , where $\mu = (\cos\Theta - V_p/V)/\sin\Theta$ .<br><br><table style="margin-left: auto; margin-right: auto;"> <tr> <td style="text-align: center;"><u><math>\mu</math></u></td> <td style="text-align: center;"><u>Assessment</u></td> </tr> <tr> <td style="text-align: center;">0.0 - 0.25</td> <td style="text-align: center;">Good</td> </tr> <tr> <td style="text-align: center;">0.26 - 0.35</td> <td style="text-align: center;">Fair</td> </tr> <tr> <td style="text-align: center;">&gt; 0.35</td> <td style="text-align: center;">Marginal</td> </tr> </table>  | <u><math>\mu</math></u>               | <u>Assessment</u> | 0.0 - 0.25          | Good           | 0.26 - 0.35 | Fair | > 0.35                                       | Marginal |                     | Marginal<br>(0.71) |    |    |  |   |
| <u><math>\mu</math></u>                      | <u>Assessment</u>  |                                       |                   |                     |                |             |      |  |          |                     |                    |    |    |  |   |
| 0.0 - 0.25                                   | Good   |                                       |                   |                     |                |             |      |  |          |                     |                    |    |    |  |   |
| 0.26 - 0.35                                  | Fair   |                                       |                   |                     |                |             |      |  |          |                     |                    |    |    |  |   |
| > 0.35                                       | Marginal   |                                       |                   |                     |                |             |      |  |          |                     |                    |    |    |  |   |
| g.   | The impact velocity of a hypothetical front-seat passenger against the vehicle interior, calculated from vehicle accelerations and 2.0 ft. longitudinal and 1.0 ft. lateral displacements, shall be less than:<br><br><table style="margin-left: auto; margin-right: auto;"> <tr> <td colspan="2" style="text-align: center;"><u>Occupant Impact Velocity - fps</u></td> </tr> <tr> <td style="text-align: center;"><u>Longitudinal</u></td> <td style="text-align: center;"><u>Lateral</u></td> </tr> <tr> <td style="text-align: center;">30</td> <td style="text-align: center;">25</td> </tr> </table><br>and for the vehicle highest 10-ms average accelerations subsequent to the instant of hypothetical passenger impact should be less than:<br><br><table style="margin-left: auto; margin-right: auto;"> <tr> <td colspan="2" style="text-align: center;"><u>Occupant Ridedown Accelerations - g's</u></td> </tr> <tr> <td style="text-align: center;"><u>Longitudinal</u></td> <td style="text-align: center;"><u>Lateral</u></td> </tr> <tr> <td style="text-align: center;">15</td> <td style="text-align: center;">15</td> </tr> </table> | <u>Occupant Impact Velocity - fps</u> |                   | <u>Longitudinal</u> | <u>Lateral</u> | 30          | 25   | <u>Occupant Ridedown Accelerations - g's</u> |          | <u>Longitudinal</u> | <u>Lateral</u>     | 15 | 15 |  | S |
| <u>Occupant Impact Velocity - fps</u>        |  |                                       |                   |                     |                |             |      |  |          |                     |                    |    |    |  |   |
| <u>Longitudinal</u>                          | <u>Lateral</u>   |                                       |                   |                     |                |             |      |  |          |                     |                    |    |    |  |   |
| 30   | 25   |                                       |                   |                     |                |             |      |  |          |                     |                    |    |    |  |   |
| <u>Occupant Ridedown Accelerations - g's</u> |  |                                       |                   |                     |                |             |      |  |          |                     |                    |    |    |  |   |
| <u>Longitudinal</u>                          | <u>Lateral</u>   |                                       |                   |                     |                |             |      |  |          |                     |                    |    |    |  |   |
| 15   | 15   |                                       |                   |                     |                |             |      |  |          |                     |                    |    |    |  |   |
| h.   | Vehicle exit angle from the barrier shall not be more than 12 degrees. Within 100 ft. plus the length of the test vehicle from the point of initial impact with the railing, the railing side of the vehicle shall move no more than 20 ft. from the line of the traffic face of the railing.  |                                       | S                 |                     |                |             |      |  |          |                     |                    |    |    |  |   |

S - Satisfactory  
M - Marginal  
U - Unsatisfactory

9. The test vehicle's exit angle was satisfactory (2.8 degrees < 12 degrees [60% of 20° ]).

Based upon the above listed items, the results of Test I6-1 are acceptable according to the NCHRP 230 (1) and AASHTO (3) guidelines.



## **6. RECOMMENDATIONS**

The Iowa W-Beam Approach Guardrail Transition Section has met the required performance evaluation criteria set forth by NCHRP 230 (1) and AASHTO (2). Thus, it is our recommendation that the Federal Highway Administration accept this installation so that its use on Federal Aid Projects can be approved.

## 7. REFERENCES

1. "Recommended Procedures for the Safety Performance Evaluation of Highway Appurtenances," National Cooperative Highway Research Program Report 230, Transportation Research Board, Washington, D.C., March, 1981.
2. "Guide Specifications for Bridge Railings," American Association of State Highways and Transportation Officials, Washington, D.C., 1989.
3. Hinch, J., Yang, T-L, and Owings, R., "Guidance Systems for Vehicle Testing," ENSCO, Inc., Springfield, VA, 1986.
4. "Vehicle Damage Scale for Traffic Accident Investigators," Traffic Accident Data Project Technical Bulletin No. 1, National Safety Council, Chicago, IL, 1971.
5. "Collision Deformation Classification, Recommended Practice J224 Mar 80," SAE Handbook Vol. 4, Society of Automotive Engineers, Warrendale, Penn., 1985.

## 8. APPENDICES

**APPENDIX A.**

**CONCRETE COMPRESSIVE STRENGTHS  
AND DESIGN MIX SPECIFICATIONS**

**MATERIALS TESTING LABORATORY**  
**DEPARTMENT OF ENGINEERING MECHANICS**  
 UNIVERSITY OF NEBRASKA

Course \_\_\_\_\_

Test 28 day Strength

Material  $f_c = ?$

Performed by Jim Holloway Date 10/23/89

Testing Machine 440 BTE 64305 Calibrator good thru 6/90.

Specimen Data \_\_\_\_\_

| Cyl. # | $C_1$ (ft)<br>Circumference | $C_2$ (ft) | $C_3$ (ft) | $\bar{C}$ (ft) | $r = \frac{C}{2\pi}$ (in) | $A = \pi r^2$ (in) <sup>2</sup> | $P = \text{load @ yield}$ (#) | STRENGTH = $P/A$ (psi) |
|--------|-----------------------------|------------|------------|----------------|---------------------------|---------------------------------|-------------------------------|------------------------|
| 1      | 1.580                       | 1.585      | 1.590      | 1.585          | 3.027                     | 28.786                          | 106,000                       | 3692.5                 |
| 2      | 1.570                       | 1.580      | 1.590      | 1.580          | 3.018                     | 28.615                          | 112,500                       | 3931.5                 |
| 3      | 1.570                       | 1.580      | 1.580      | 1.577          | 3.012                     | 28.501                          | 99,500                        | 3491.1                 |
|        |                             |            |            |                |                           |                                 |                               | ave 3701.6             |
|        |                             |            |            |                |                           |                                 |                               |                        |
|        |                             |            |            |                |                           |                                 |                               |                        |
|        |                             |            |            |                |                           |                                 |                               |                        |
|        |                             |            |            |                |                           |                                 |                               |                        |
|        |                             |            |            |                |                           |                                 |                               |                        |
|        |                             |            |            |                |                           |                                 |                               |                        |
|        |                             |            |            |                |                           |                                 |                               |                        |
|        |                             |            |            |                |                           |                                 |                               |                        |
|        |                             |            |            |                |                           |                                 |                               |                        |
|        |                             |            |            |                |                           |                                 |                               |                        |
|        |                             |            |            |                |                           |                                 |                               |                        |
|        |                             |            |            |                |                           |                                 |                               |                        |
|        |                             |            |            |                |                           |                                 |                               |                        |
|        |                             |            |            |                |                           |                                 |                               |                        |
|        |                             |            |            |                |                           |                                 |                               |                        |
|        |                             |            |            |                |                           |                                 |                               |                        |
|        |                             |            |            |                |                           |                                 |                               |                        |
|        |                             |            |            |                |                           |                                 |                               |                        |
|        |                             |            |            |                |                           |                                 |                               |                        |
|        |                             |            |            |                |                           |                                 |                               |                        |
|        |                             |            |            |                |                           |                                 |                               |                        |
|        |                             |            |            |                |                           |                                 |                               |                        |

# GENERAL TESTING LABORATORIES

TELEPHONE  
402-464-6384

P. O. BOX 29208  
LINCOLN, NEBRASKA 68529

September 15, 1989

To: Ray Ayars  
Ready Mixed Concrete Co  
6200 Cornhusker Hwy  
Lincoln, Nebraska 68529

RE: State Mix Design, 47B-PHE

| MATERIAL                                  | WT/CU YD | SUPPLIER                               |
|---|----------|--|
| Portland Cement,<br>Type III, Grey        | 682 lb   | Lone Star Cement<br>Bonner Springs, KS |
| 47B Limestone (SSD)                       | 880 lb   | Kerford Limestone<br>Weeping Water, NE |
| 47B Sand & Gravel (SSD)                   | 2040 lb  | Western Sand & Gravel<br>Ashland, NE   |
| Air Entraining<br>Admixture, Prokrete AES | 3.5 oz   | Prokrete Industries<br>Denver, CO      |
| Water Reducing<br>Admixture, Prokrete N   | 13.5 oz  | Prokrete Industries<br>Denver, CO      |
| Total Water                               | 34 gal   | Lincoln Water System<br>Lincoln, NE    |

General Testing Lab,



Bill Fuller, Manager

# GENERAL TESTING LABORATORIES

TELEPHONE  
402-464-6384

P. O. BOX 29208  
LINCOLN, NEBRASKA 68529

September 15, 1989

## AGGREGATE DATA

---

### 47B LIMESTONE:

|                              |      |       |      |       |    |        |     |        |      |
|------------------------------|------|-------|------|-------|----|--------|-----|--------|------|
| Screen                       | 1"   | 3/4"  | 1/2" | 3/8"  | #4 | #8     | #16 | #20    | #200 |
| Spec:                        | 0/8  | 10/34 |      | 55/85 |    | 88/100 |     | 94/100 |      |
| % Retained:                  | 6    | 19    | 33   | 57    | 87 | 94     | 96  | 97     | 98   |
| Bulk Specific Gravity (SSD): | 2.66 |       |      |       |    |        |     |        |      |
| 24 Hour Absorption:          | 1.1% |       |      |       |    |        |     |        |      |

### 47B SAND & GRAVEL:

|                              |      |      |    |       |     |       |     |        |      |
|------------------------------|------|------|----|-------|-----|-------|-----|--------|------|
| Screen:                      | 3/8" | #4   | #8 | #10   | #16 | #30   | #50 | #100   | #200 |
| Spec:                        |      | 3/23 |    | 30/50 |     | 60/84 |     | 97/100 |      |
| % Retained:                  | 1    | 13   | 29 | 36    | 51  | 76    | 93  | 99     | 99.8 |
| Bulk Specific Gravity (SSD): | 2.62 |      |    |       |     |       |     |        |      |
| 24 Hour Absorption:          | 0.6% |      |    |       |     |       |     |        |      |



**PROKRETE Industries**  
**ProChemTechnology, Inc.**

3990 Havana Street • Denver, Colorado 80239

Telephone: (303) 375-0990

Telefax: (303) 375-9306

January 20, 1989

**MANUFACTURER'S  
CERTIFICATION**

Lincoln Ready Mix  
P. O. Box 82114  
Lincoln, NE 68501

RE: ProChemTechnology, Inc. Air Entraining Solution (Regular)

Gentlemen:

We hereby certify that ProChemTechnology, Inc. Air Entraining Solution is manufactured to comply with the requirements of the Department of Transportation, Bureau of Reclamation, U.S. Corps of Engineers Specification CRD C-13-79, as well as ASTM Specification C-260-86 and AASHTO Specification M-154-79.

It is further certified that ProChemTechnology, Inc. Air Entraining Solution does not contain any form of Calcium Chloride.

It is also certified that the above stated material has not been changed or altered in any way.

Prokrete Industries  
ProChemTechnology, Inc.

Larry J. Kern  
Director of Research and Development





**PROKRETE Industries**  
**ProChemTechnology, Inc.**

3990 Havana Street • Denver, Colorado 80239

Telephone: (303) 375-0990

Telefax: (303) 375-9306

January 20, 1989

**MANUFACTURER'S  
CERTIFICATION**

Lincoln Ready Mix  
P. O. Box 82114  
Lincoln, NE 68501

RE: ProChemTechnology, Inc. Pro-Krete N

Gentlemen:

This is to certify that ProChemTechnology, Inc. Pro-Krete N conforms to the requirements of ASTM C-494-86, AASHTO M-194-84 and CRD C-87-86, Type A admixture when used at the rate of two fluid ounces per 100 pounds of cement.

ProChemTechnology, Inc. Pro-Krete N is a highly purified and multiple-component admixture which does not contain any form of Calcium Chloride.

Prokrete Industries  
ProChemTechnology, Inc.

Larry J. Kern  
Director of Research and Development

**APPENDIX B.**

**RELEVANT IDOT CORRESPONDENCE**



# Iowa Department of Transportation

800 Lincoln Way, Ames, Iowa 50010 515/239-1206

October 26, 1989

Ref. No. State Wide Safety  
BRF-000S(2)--38-00

Dr. Edward R. Post  
Civil Engineering Department  
University of Nebraska  
W348 Nebraska Hall  
Lincoln, Nebraska 68588-0531

Dear Dr. Post:

This letter is to confirm the phone call on September 25, 1989, relating to the Rail Crash Test Program, Task No. 6. The Iowa DOT wants the test to be carried out as stated in Appendix A of the Supplemental Agreement No. 1, dated July 5, 1989 and as modified by Supplemental Agreement No. 2, dated September 12, 1989.

These agreements require one test with a 5.4 kip pickup traveling 60 MPH and at a 20 degree angle with the guardrail. The impact point will be 15 feet upstream from the end of the concrete rail, which is a point between guardrail posts 5 and 6.

Because of the possibility of additional transition section crash tests we would request that the installation as built be left in place at the conclusion of task No. 6 until we can determine the need for additional testing.

Sincerely,

A handwritten signature in cursive script, appearing to read "William A. Lundquist".

William A. Lundquist  
Bridge Engineer

WAL:rcw

cc: R. Humphrey  
G. Anderson  
G. Sisson  
B. Brakke

**APPENDIX C.**

**ACCELEROMETER DATA ANALYSIS**

|  | Page |
|--|------|
| C-1 Graph of Longitudinal Deceleration, Test I6-1 .....          | 60   |
| C-2 Graph of Longitudinal Deceleration, Test I6-1 .....          | 61   |
| C-3 Graph of Vehicle Change in Speed, Test I6-1 .....            | 62   |
| C-4 Graph of Vehicle Change in Speed, Test I6-1 .....            | 63   |
| C-5 Graph of Longitudinal Occupant Displacement, Test I6-1 ..... | 64   |
| C-6 Graph of Longitudinal Occupant Displacement, Test I6-1 ..... | 65   |
| C-7 Graph of Lateral Deceleration, Test I6-1 .....               | 66   |
| C-8 Graph of Lateral Occupant Impact Velocity, Test I6-1 .....   | 67   |
| C-9 Graph of Lateral Occupant Displacement, Test I6-1 .....      | 68   |

I614063

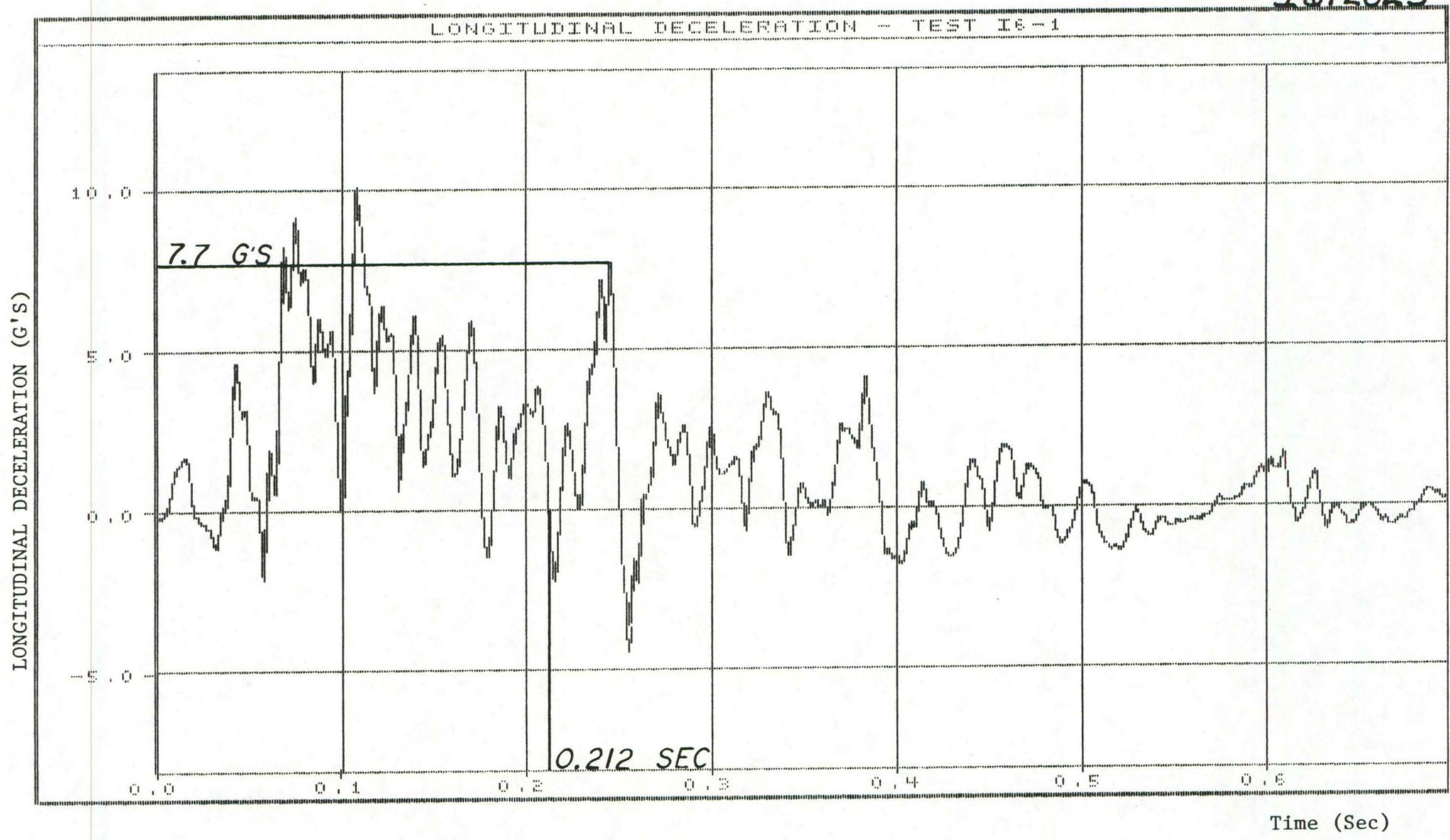

FIGURE C-1. GRAPH OF LONGITUDINAL DECELERATION, TEST I6-1.

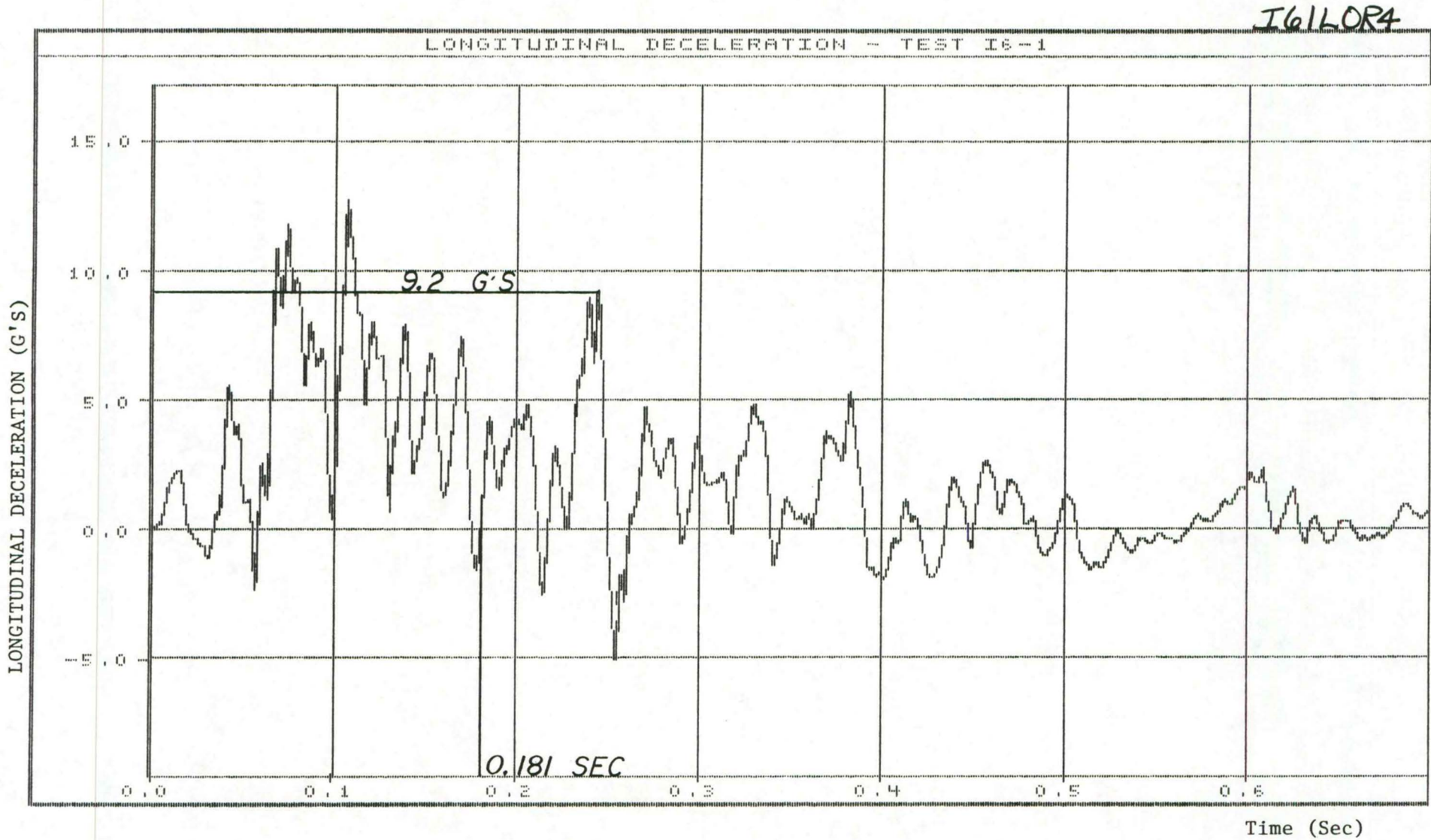
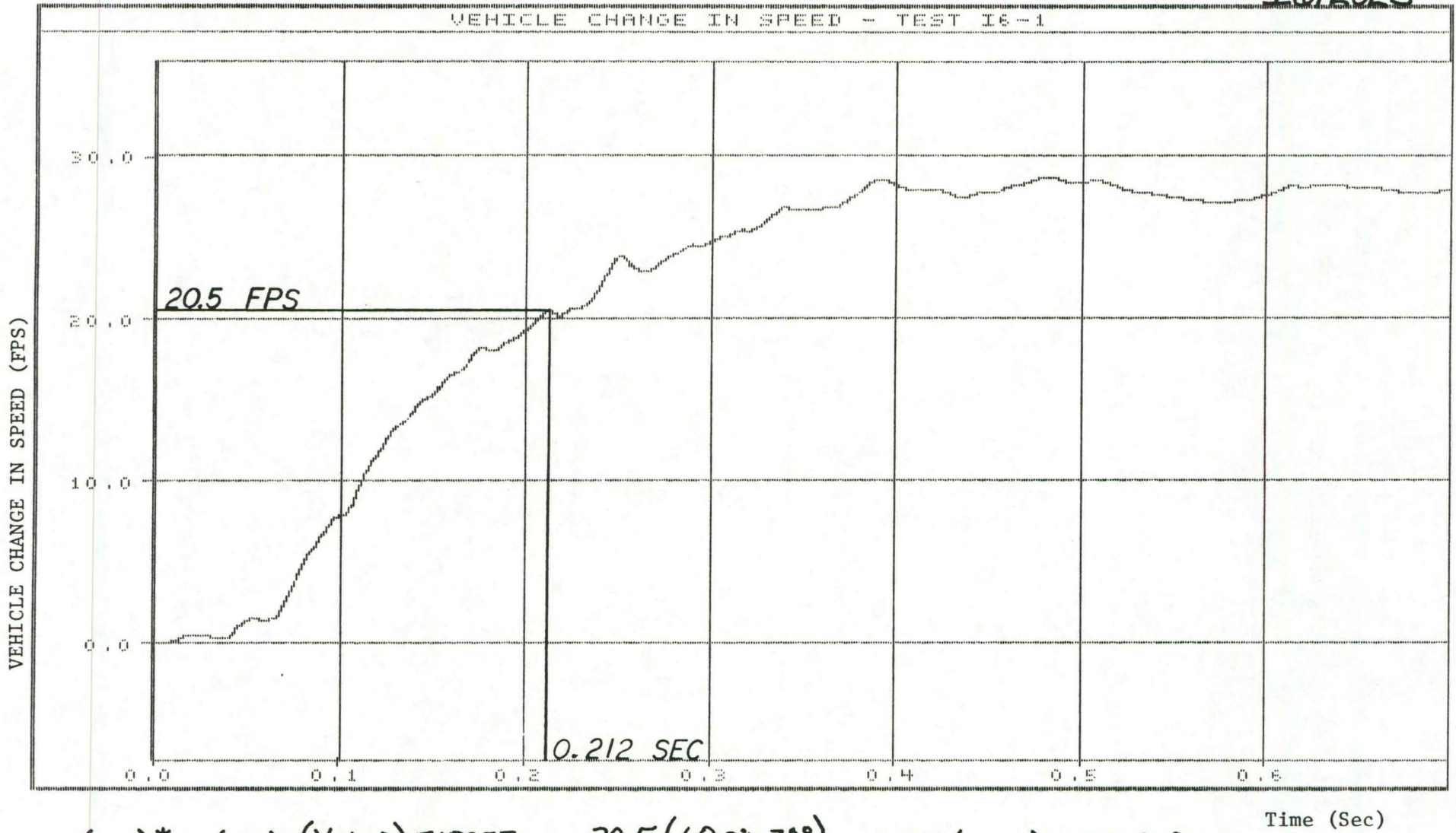

FIGURE C-2. GRAPH OF LONGITUDINAL DECELERATION, TEST I6-1.

I614023



$$(\Delta V)^* = (\Delta V) \frac{(V \sin \theta)_{\text{TARGET}}}{(V \sin \theta)_{\text{ACTUAL}}} = \frac{20.5 (60 \sin 20^\circ)}{(61.45 \sin 20^\circ)} = 20.5 (0.9764) = 20.0 \text{ fps}$$

FIGURE C-3. GRAPH OF VEHICLE CHANGE IN SPEED, TEST I6-1.

I61LOR4

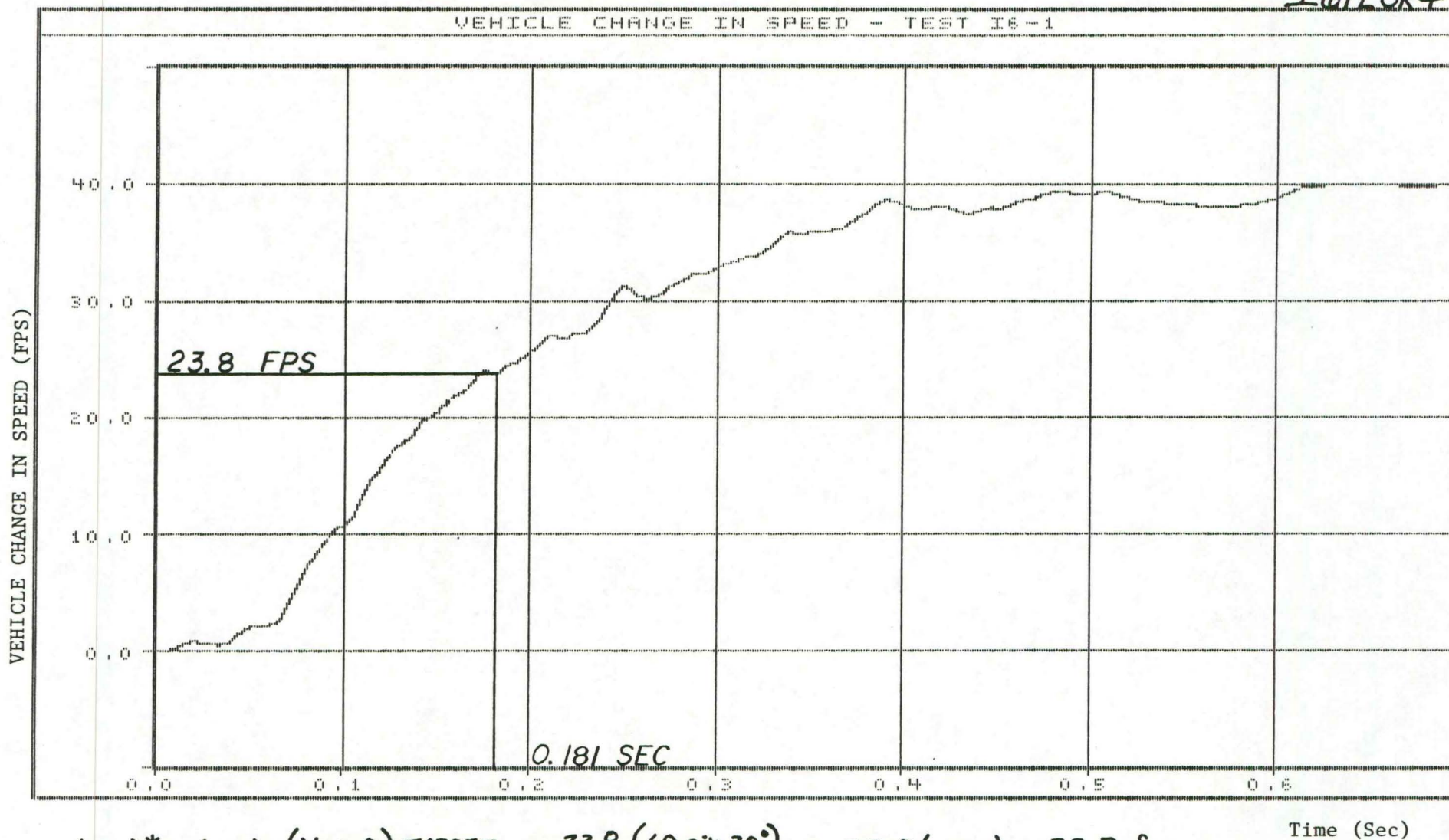

$$(\Delta V)^* = (\Delta V) \frac{(V \sin \theta)_{TARGET}}{(V \sin \theta)_{ACTUAL}} = \frac{23.8 (60 \sin 20^\circ)}{(61.45 \sin 20^\circ)} = 23.8 (0.9767) = 23.2 \text{ fps}$$

FIGURE C-4. GRAPH OF VEHICLE CHANGE IN SPEED, TEST I6-1.



I6110L3

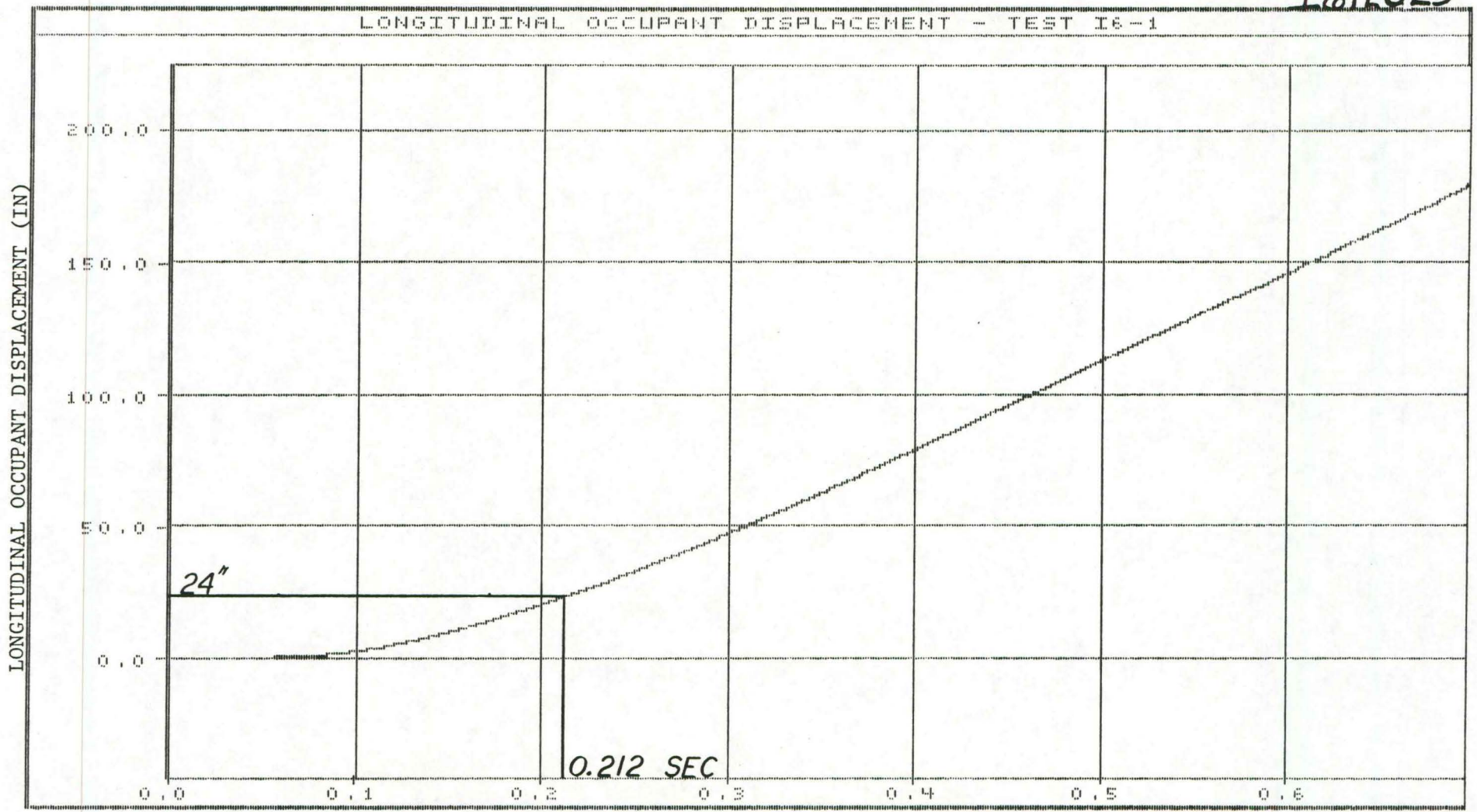

FIGURE C-5. GRAPH OF LONGITUDINAL OCCUPANT DISPLACEMENT, TEST I6-1.

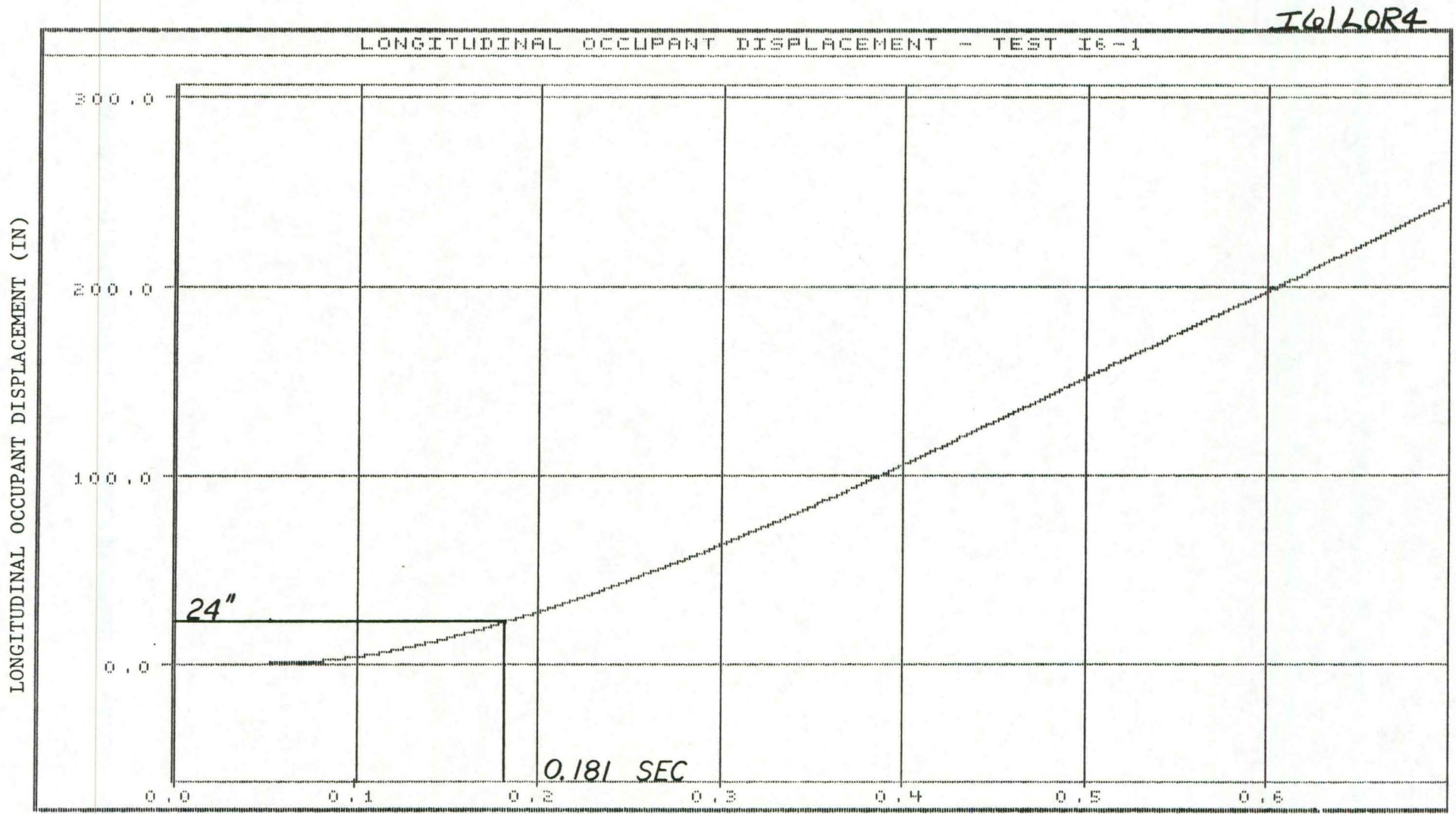

FIGURE C-6. GRAPH OF LONGITUDINAL OCCUPANT DISPLACEMENT, TEST I6-1.

I611A1

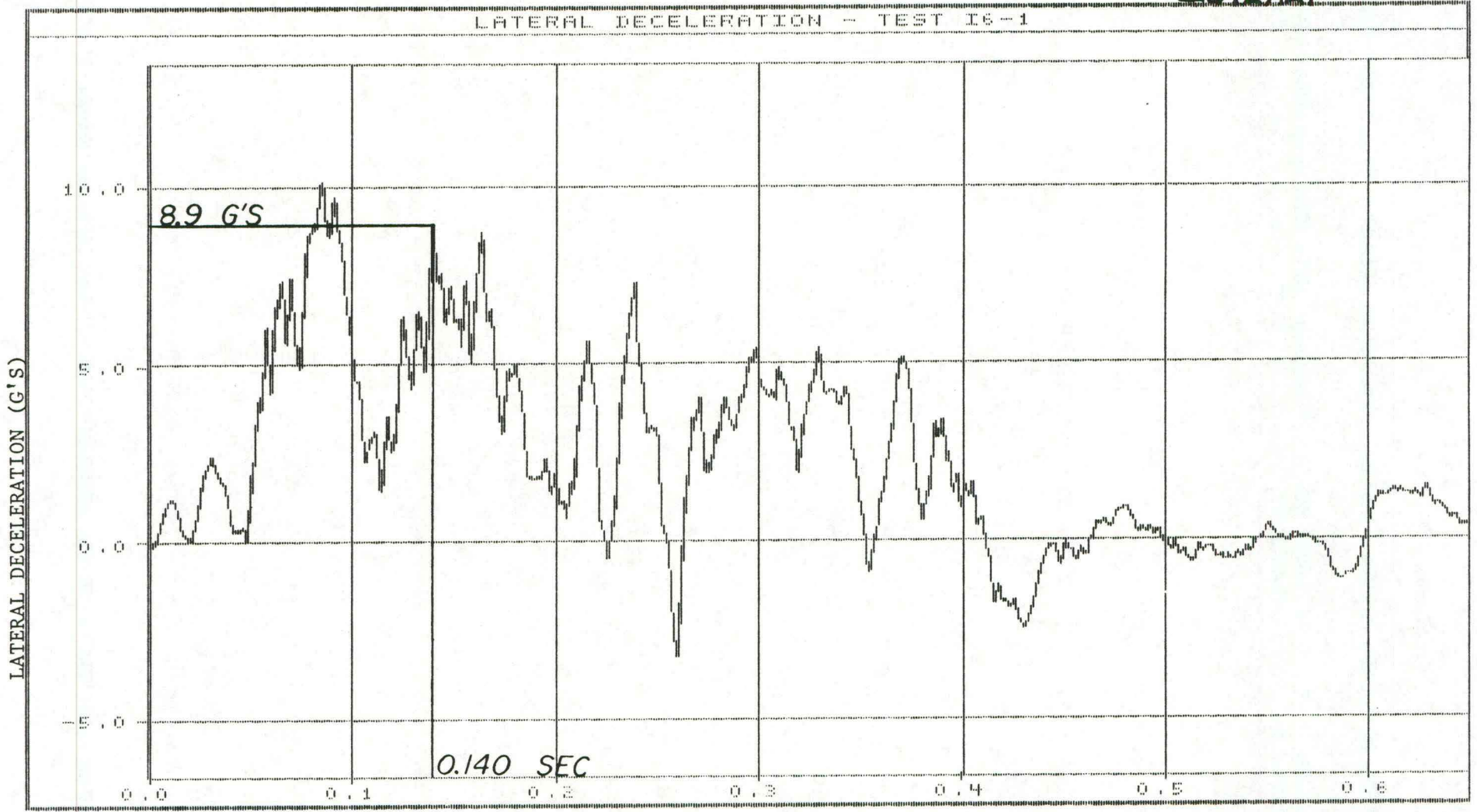
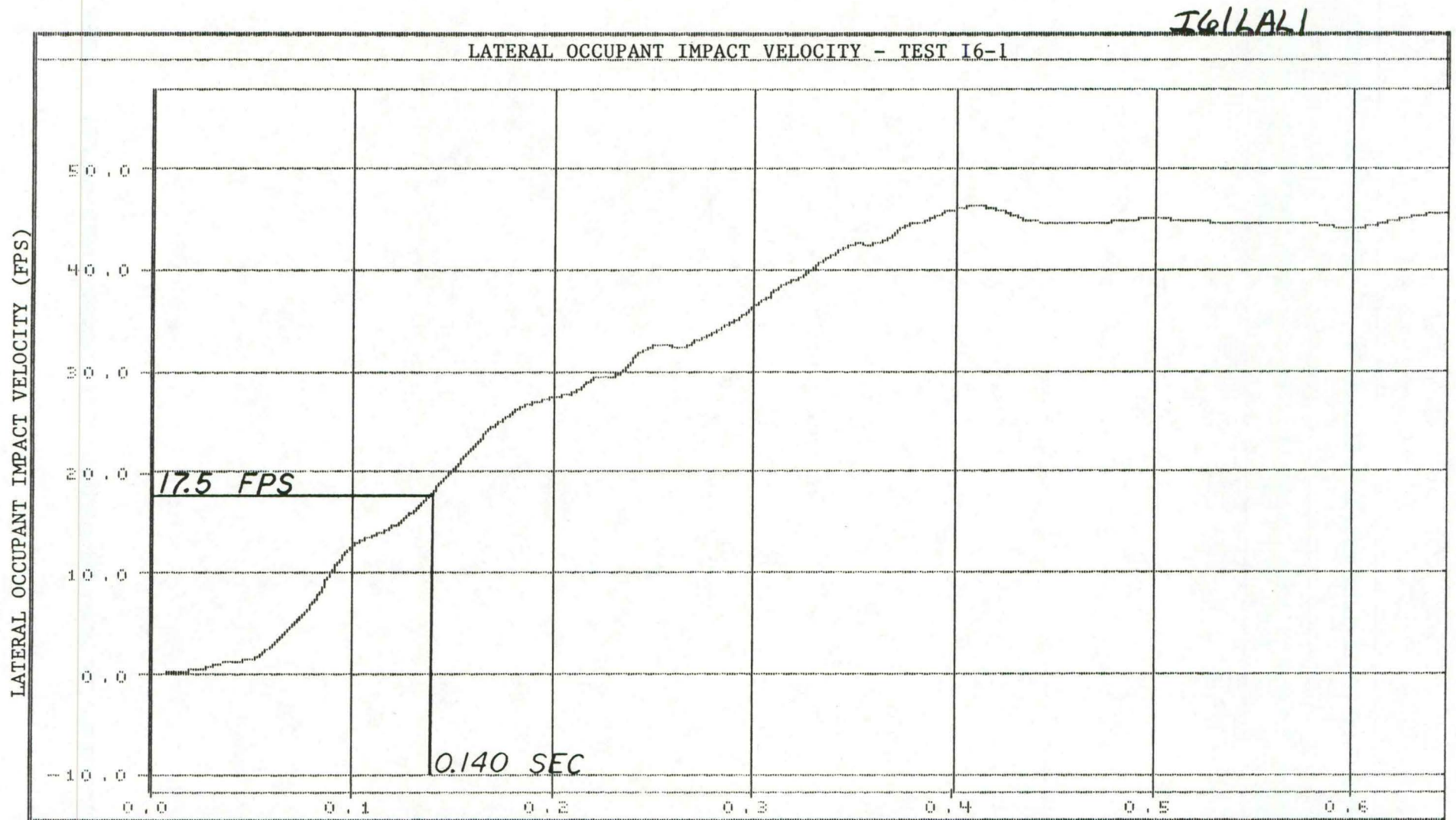

FIGURE C-7. GRAPH OF LATERAL DECELERATION, TEST I6-1.



$$(\Delta V)^* = (\Delta V) \frac{(V \sin \theta)_{\text{TARGET}}}{(V \sin \theta)_{\text{ACTUAL}}} = \frac{17.5 (60 \sin 20^\circ)}{(61.45 \sin 20^\circ)} = 17.5 (0.9764) = 17.1 \text{ fps}$$

FIGURE C-8. GRAPH OF LATERAL OCCUPANT IMPACT VELOCITY, TEST I6-1.

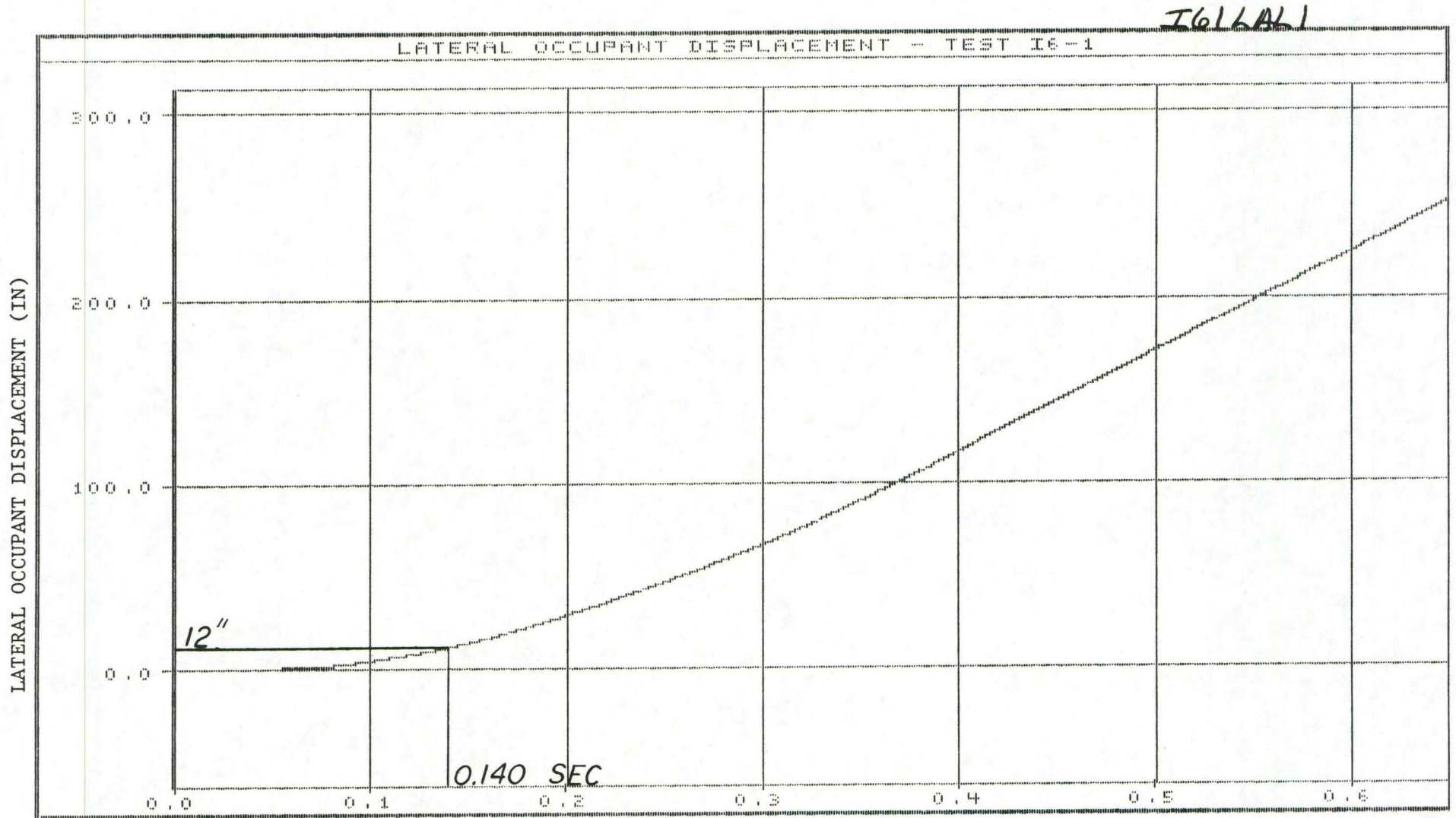

FIGURE C-9. GRAPH OF LATERAL OCCUPANT DISPLACEMENT, TEST I6-1.

STATE LIBRARY OF IOWA



3 1723 02116 8828