

S
542
.I8
S74
no.64
1969

Disease Consequences of Intensive and Extensive Culture of Field Crops

Edited by J. Artie Browning

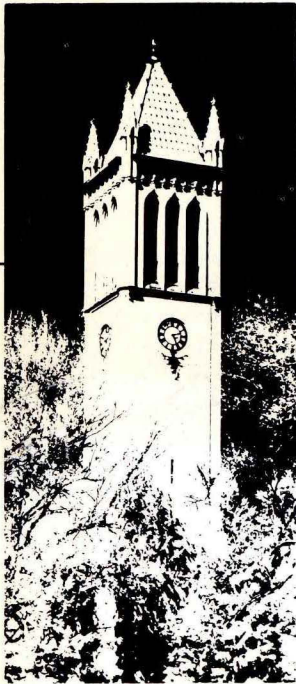

Department of Botany and Plant Pathology

Special Report No. 64

Agriculture and Home Economics Experiment Station
Iowa State University of Science and Technology
Ames, Iowa. December 1969

IOWA STATE TRAVELING LIBRARY
DES MOINES, IOWA

PREFACE

Threats of diseases, weeds, insects, production practices, etc., to our major crops should be the concern—indeed, the responsibility—of plant scientists and other agricultural leaders. Possible disease threats from the intensive and extensive culture of field crops in the Corn Belt were examined at a symposium of the North Central Division of the American Phytopathological Society at their 1967 meeting in Ames. Papers presented in this report, by agronomists as well as plant pathologists, are products of that symposium.

Six of the papers discuss different areas of plant pathology in relation to intensive and extensive production of corn, soybeans, and oats—crops traditionally important in the Corn Belt. The symposium was organized, in general, around the double dichotomy of introduced (soybeans and oats) versus indigenous (corn) crops, and of residual pathogens (pathogens that perpetuate themselves within the Corn Belt) versus continental pathogens (pathogens such as the cereal rusts that blow from one region to another). With this organization, the broad subject could be examined in perspective. For example:

(a) Why have oats from the beginning, and soybeans after several years of intensive cultivation, been plagued by diseases? Both are away from their lands of origin where they once lived in balance with their pests and pathogens. Corn, on the other hand, indigenous to the Americas, is notably free from extensive epiphytotics. Is any protection provided by indigenesness per se that Corn Belt farmers can count on against potential hazards to their major crop? Corn rust, against which plant breeders have maintained the generalized resistance passed along from the selections of the American Indian, suggests that there may be—if interpreted genetically and used wisely.

(b) Do residual pathogens threaten crops in the Corn Belt differently than do continental pathogens? Experience with oats suggests that they do. Oats is remarkably disease free, except for diseases caused by continental pathogens. Understanding this suggests important and promising ways to control these pathogens—and to conserve resistance genes—that would not apply to the more important pathogens of corn and soybeans.

The probable importance of diseases in future Corn Belt agriculture can be discussed knowledgeably by concerned plant scientists only after an authoritative appraisal of trends in agricultural practices and production. Hence, the first paper following the introduction.

The symposium was conceived by the late Professor Walter F. Buchholtz of the Department of Botany and Plant Pathology at Iowa State University. Dr. Buchholtz was president of the North Central Division of the American Phytopathological Society at the time of his death. A native Iowan and farmer as well as plant scientist, he was deeply concerned about the potential hazards of present trends in Corn Belt agriculture. The symposium and papers in this special report are respectfully dedicated to his memory.

—J. Artie Browning
Iowa State University
Ames, Iowa
September 1969

CONTENTS

Introduction <i>J. Artie Browning</i>	5
Trends in practices and production of major Corn Belt crops <i>J. W. Pendleton</i>	6
Effect of intensive cultural practices on soil-borne and related corn diseases <i>M. G. Boosalis, W. L. Colville, and D. R. Sumner</i>	12
Structural design aspects of corn stalk-rot damage under intensified fertilizer usage <i>D. C. Foley</i>	21
Widely based resistance to rust in corn <i>A. L. Hooker</i>	28
Consequences of intensive cultural practices on soybean diseases in the Corn Belt <i>John Dunleavy</i>	35
Soybean-cyst-nematode damage as associated with the intensive culture of soybeans in southeastern Missouri <i>A. H. Hagge</i>	41
Regional deployment for conservation of oat crown-rust resistance genes <i>J. Artie Browning, M. D. Simons, K. J. Frey, and H. C. Murphy</i>	49

2-24-70

Disease Consequences of Intensive and Extensive Culture of Field Crops

Edited by J. Artie Browning

INTRODUCTION

Agriculture in the Corn Belt is big business. It is a specialized business, depending very much on only a few intensively grown crops. During the 5-year period 1964-68, farmers in Ohio, Indiana, Illinois, Iowa, and contiguous corn-producing states harvested annual averages of 45, 24, and 12 millions of acres of corn, soybeans, and oats, respectively. These acreages made up 79%, 66%, and 69% of the national acreages of these crops, and produced 85% of the nation's corn, 70% of the soybeans, and 73% of the oats. Marketed directly or through livestock, these three crops and forages traditionally have formed the major basis of agriculture in the Corn Belt.

Corn Belt agriculture is big business, but is it good business, reasonably free from unnecessary risk? In business and finance, for example, diversification, not specialization, hedges against high risk. Diversity also aids stability in the biological world. Interspecific diversity (different species growing at the same time or successively on the same land) and intraspecific diversity (genetic differences within species) are nature's steadying forces assuring orderly evolution and insuring against chaotic revolution.

Interspecific diversity now largely is lacking in Corn Belt agriculture. This might not be of concern if there were assurances that the status quo could be maintained, that there were not unknown pestilences or other dangers beyond the horizon. But can the status quo be maintained? Corn Belt farmers are being pushed into increasing production by two forces: One, materialistic, demands more efficient production. The other, humanistic, is the realization that we live in a hungry world and that the Corn Belt can help feed that world. Responding to these forces, Corn Belt farmers are stopping some traditional practices. Crop rotation is one such practice. As a form of interspecific diversity, crop rotation has been among the most simple and fundamental disease- and pest-control measures. Instead, farmers are growing fewer crop species, even in monoculture, on the same land year after year.

Lacking interspecific diversity, what of intraspecific? A relatively small but increasing number of soybean cultivars covers 4 million acres of Iowa land. Diversity for disease reaction formerly was absent from oats, but multiline oat cultivars (genetically diverse for crown-rust reaction) now are avail-

able though not yet in general use. The Corn Belt is not the unit of control for some pathogens, however, and virulent inoculum of the rust fungi continues to blow in from overwintering areas to the south. Corn (which covers about a third of Iowa, for example) formerly was planted largely to double-cross hybrids, the first of which were used to avoid certain handicaps in seed production of single crosses. It developed, however, that the added genetic homeostasis of double crosses was far more important than their seed-production advantages. The genetic variability of double crosses that resulted in their consistent performance over space and time was the "gyroscope that holds the ship steady in a surging sea."¹ Now, the trend is toward use of single crosses that maximize yield in a narrow environment.

Corn Belt farmers, not only are growing fewer species of crops, but also are intensifying production with high levels of fertilizer, high plant populations, close row spacings, heavy applications of pesticides, reduced tillage, and supplemental irrigation. The potential hazards of current production trends and practices in the Corn Belt must be examined carefully, and agricultural leaders must be made aware of possible disease and other consequences. Certainly, the extensive culture of single-resistance genotypes is never indicated, but intensive culture, perhaps being economically unavoidable, is.

What do we know now, and what research is needed to assure safe, stable, continuous, intensive cropping in a given environment? Can a team of plant scientists design a better cultural regime to enable present cultivars to withstand whatever develops? Can new cultivars be developed that will thrive over time under this abnormal, manmade pressure to yield? and that will stand until man can harvest that yield? What is the effect of fertility on disease resistance? Are better generalized, more stable genetic resistance types possible? Can responsible use of pesticides safely be combined with improved cultivars and better cultural regimes in an integrated production package—a symphony for production of superior field crops for the benefit of all mankind? Concerned plant scientists should analyze this situation in depth because the stakes are high.

¹D. F. Jones. 1958. Heterosis and homeostasis in evolution and in applied genetics. *Amer. Natur.* 92:321-328.

Trends in Practices and Production of Major Corn Belt Crops¹

by J. W. Pendleton²

ABSTRACT

Present midwestern agriculture is characterized best by the word "dynamic." Top farmers adopt agricultural technological improvements rapidly. Indeed, they will try new practices before they are tested adequately and will incorporate them into their entire operation if even small economic returns or increased efficiency are evident. This has led leading farmers to drop crop rotations on more level land and to concentrate on the superior culture of corn and soybeans. Leading farmers plant high-quality seed early in the season in narrow rows to obtain a high plant population. They use high rates of fertilizer and reduced tillage, relying primarily on herbicides to control weeds. They harvest early with large equipment.

These intensive agricultural practices have not resulted in the losses of topsoil from erosion or the yield losses from insects and diseases that many predicted. Still, increases of some plant pathogens have occurred in the Corn Belt and, as pressures are increased in the 1970's for the individual plant to yield still more, the risks and the stakes will become higher. The future for agronomic and pathological research, therefore, has never been more challenging.

INTRODUCTION

Technology and economic forces are changing agriculture in Mid-America. Economical water, rail, and highway transportation have helped make America's Heartland the United States' and World's Foodbasket. The appearance of industry in traditionally rural areas and the ensuing labor competition and costs continue to cause tremendous changes in farming enterprises: more specialization, larger operations, "super" machines, and more dependence on chemical energy.

Technology is permitting farm yields never dreamed of a decade ago. Such yields are the result of sound management by better farmers, of putting all agricultural technology together. One traditional recommendation for controlling plant diseases (crop rotation) is as out-of-date as a 2-row corn planter in the north-central states. In addition to crop rotations, technology is changing in the areas of seed quality, planting date, plant populations and patterns, tillage, weed control, harvesting, and fertility. The objectives of this paper are to discuss some of the changing agronomic practices and their implications for plant pathology. Relatively greater emphasis will be placed on corn and soybeans.

ACREAGE AND PRODUCTION TRENDS

First, consider the acreages of major crops grown in the 12 north-central states (fig. 1). The acreage of a traditionally important crop (spring oats) has been cut in half in the past 12 years. This re-

duction was most dramatic in several states east of the Mississippi River. A corresponding, but lesser, reduction occurred in acreage of forage harvested for hay. The bulk of these changing acres went to soybeans. The acreage devoted to the two crops most involved in government acreage-control programs, wheat and corn, fluctuated during this same period. Extending present acreage trends indicates that the Midwest may grow greater concentrations of fewer crop species within the area. Although acreages fluctuated during 1950-1967, the yield per acre climbed steadily. Increased production of corn, wheat, and oats was spectacular, and of soybeans and hay, substantial.

CROP ROTATIONS

Historical reasons for recommending a sequence of crops are: a) maintenance of good soil tilth and structure, b) supply of legume nitrogen for other crops, c) better water infiltration and less erosion, d) better weed control, e) less economic risk, f) better labor distribution, and g) better insect and disease control.

Many research reports indicate that rotations contribute a great deal to soil physical factors, or tilth, but this varies with soil type and cultural practice. On sandy soils, for example, tilth is not a problem, and rotations are not needed to maintain it. On silt loams or medium-textured soils, an acceptable level of tilth might well be maintained with minimum-tillage efforts. In long-time rotation studies, such as the Morrow Plots at the University of Illinois, it is very difficult to measure differences in soil tilth among rotations after 90 years of cropping. Admittedly, these plots are located on a soil

¹Contribution from the Agronomy Department, Illinois Agricultural Experiment Station, Urbana, Illinois

²Professor of Agronomy

high in organic matter. On fine-textured soils, perhaps the greatest effect of tillage is to aid plant emergence and establishment. Aldrich (2) stated that, once plants have become established, they grow about as well on compacted soils, or soils of poor tillage, as on soils of good tillage. Other detrimental effects of poor tillage are the greater power requirement for tillage and the greater runoff on sloping fields. Practices the monocultural farmer can follow to counter these and maintain good soil structure and tillage are to use more fertilizer, grow more residue, and use less tillage. A corn mono-

culture at high yield levels with only the grain removed will add more plant residue to the soil than will most rotations.

An oft-quoted axiom is that a good rotation should contain a certain proportion of untilled cropland, preferably planted to a legume. This was considered necessary at one time to maintain organic matter and soil tillage and to provide an economical supply of nitrogen. When corn was 22 to 50 cents per bu and nitrogen was scarce and 15 cents per lb., this was correct. As corn prices and ease of nitrogen application increased and as the cost of nitrogen fertilizer decreased, however, the status of legumes as a nitrogen source was altered considerably.

Water implications sometimes are overlooked in legume rotations. In subhumid and semiarid regions, corn following a deep-rooted crop such as alfalfa sometimes gives disappointingly low yields. Even in drouthy springs in the humid Corn Belt, a previous alfalfa crop can leave soil moisture depleted. Hobbs (8) reported that 4-year-old alfalfa utilized soil moisture to a depth of 18 feet. At the same time, bromegrass removed moisture to a depth of 4 feet. Several Nebraska and Kansas dryland investigators also reported that alfalfa can remove soil moisture to great depths and that precipitation over several years is required to replenish this. A grass-legume crop does not automatically result in high water-infiltration rates. Alderfer and Robinson (1) reported very low infiltration rates on heavily grazed pastures. Therefore, rotations may not generally improve available water and may actually result in less available moisture if the preceding crop had a high water requirement or grew late into the fall and the land was plowed late the next spring.

It is sometimes said that less erosion and water loss will occur with a rotation containing meadows than with intensive row crops. Actually, least erosion will occur on a given farm if all row crops are grown on level fields and all small grains, meadows, and pastures are kept on sloping fields.

Another advantage often advanced for rotations is better weed control, but a grower can mechanize to control weeds in a few crops better than in many crops. A wide selection of effective chemical herbicides is now available in pre- or post-emergence formulations to supplement mechanical weed control methods.

Better seasonal distribution of labor and not having "all the eggs in one basket" are cited as advantages of rotations. But a grower can specialize in the production of one or two crops much more easily and with less investment than in several crop enterprises. When corn makes up only one-fourth to one-third of the total acreage, it often is more difficult to justify investments in machinery such as a new corn combine or picker-sheller. Moreover, corn planting and cultivation may take precedence over hay making, with a resultant lowering of hay yields and quality. The question of having "all the eggs in one basket" must be weighed against the total economic income. Since we have few high-income crops, the substitution of low-value crops may not make up for the long-term

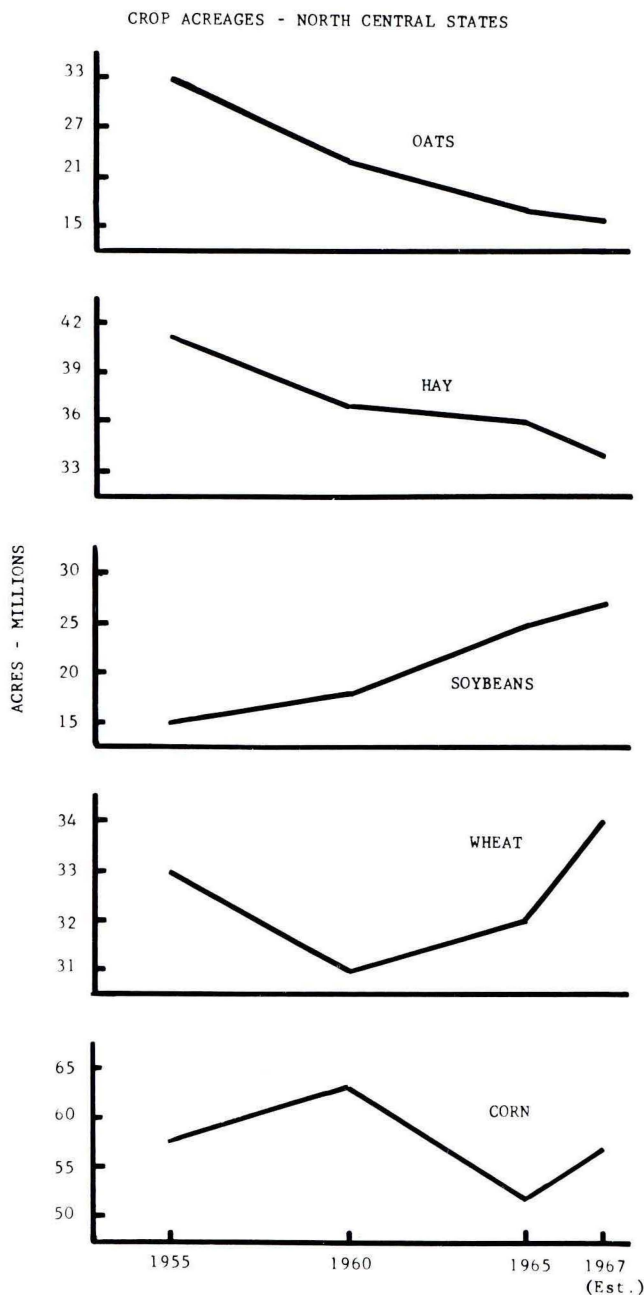

Fig. 1. Acreage trends of the primary agronomic crops of the north-central states, 1955-1967.

economic advantage of the higher-income crops. Too often, rotation effects have been evaluated on an individual field basis and measured entirely in long-term crop yields. Rotations must be considered on the basis of both short-term and long-term income from the total farm. Some growers thrive on peak work periods and pressures if they have free time during other seasons of the year.

Present agricultural technological progress has permitted the farmer greater freedom in choosing his rotations. Hughes and Henson (10) stated that the best rotation for greatest profit over a period of years depends on the farmer's management capabilities, land, equipment, livestock, and labor and that, on high-priced land, rotations including grasses and legumes must be tied closely to livestock farming. Livestock farmers generally will continue to follow multicrop rotations to have a desirable combination of grain, hay, and pasture and to have straw for bedding animals. But even on livestock farms, there is a growing trend away from the use of a standard rotation across all fields to one of growing fewer crop species on a given field choosing them according to soil type, topography, and water regime.

Control of insects and diseases is often listed among the advantages of rotations. But now many farmers rely on chemicals to control insect pests. Certain diseases increase with monoculture, and these will be emphasized in succeeding papers. Both corn and soybeans, however, have been grown continuously for many years in Illinois without serious yield reductions from a buildup of plant pathogens. The year 1968 marked the 93rd year of continuous corn on the Morrow Plots of the Illinois Agricultural Experiment Station. With proper culture and fertilization, the apparent health and yield of plants grown on these plots have never been better. Soybeans have been grown continuously for 14 and 15 years, respectively, at the Hartsburg Agronomy Research Field and at the Agronomy Research Center in Urbana with no evident disease buildup. Mr. John Reiser, Ashland, won the Illinois soybean yield contest 3 times and was third in the nation one year with yields from fields that had been in soybeans the previous year. One of his best producing soybean fields in 1967 had been in continuous soybeans for 8 years. One may say that these are exceptions and that destructive pathogens eventually will build up to epiphytotic proportions. But might not one also ask if organisms favorable for soybean growth might not also increase? Perhaps too often the major factor contributing to a disease problem in a given crop is attributed to the previous crop. The primary keys to solving disease problems in monocultural systems are the planting of resistant varieties and adding specific protective chemicals to the seed or plant.

SEED QUALITY

The quality of seed being planted is a good criterion for evaluating agricultural advancement. Greater attention is being paid to seed quality in the north-central states than ever before. Midwestern

farmers increasingly demand high-quality seed and will pay a premium for it. They also desire uniform stands and growth and will pay a premium for seed- or soil-treatment chemicals to insure this.

PLANTING DATE

Considerable agronomic research and education have been devoted recently to the age-old cultural question of planting date. Basically, an early planting date lengthens the season and, with most crops in favorable areas of rainfall and temperature, results in higher yields. With corn, most workers agree that this cultural practice is one of those most likely to contribute to higher yields.

There are other advantages for early plantings. Early-sown corn will be shorter, have lower ears, and stand better. Pollination will occur earlier, before the hot, dry days of late July and August. Midwestern corn plants depend greatly on stored subsoil moisture. Early planting means early shading and a reduction of soil water evaporation. Sunlight provides the energy for photosynthesis, and the peak demand for photosynthates is at tasseling and immediately thereafter. Thus, tasseling, pollination, and ear filling should take place during the long days as near June 21 as possible. Finally, the grain of early-planted corn of a given maturity class will reach physiologic maturity earlier, the grain will dry, and harvest can begin earlier.

Another bonus from planting corn early is that the farmer is free to plant soybeans early on the same farm. Although soybeans are not as responsive as corn to planting date (and, fortunately, they can be planted late), yields of full-season, adapted varieties generally trend downward with later planting.

A grower's requirements for early planting of corn and soybeans are a brave heart, optimism, and a great deal of *planning!* He must partly accept the concept of minimum tillage and gear up accordingly. The seedbed in the row is important, but there is no need for a "lettuce bed" between rows. Research in Illinois and other states shows that yields from reduced-tillage plots are equal and sometimes superior to those from traditional finely pulverized seedbeds. Fall plowing of level land will expedite early planting and will be necessary on heavy, high-clay-content soils.

Early-maturing corn hybrids seldom, if ever, out-yield adapted full-season hybrids when both are planted early. Although they permit harvest to begin earlier in the fall, only in unusual seasons or very late plantings are early hybrids likely to yield as well as medium or late hybrids.

Because cold soil is often encountered in early plantings, the following cultural practices are necessary for maximum yields: overplanting the desired final plant population by 15-20%, planting shallow, using small amounts of row fertilizer, and controlling weed and soil-insect pests with pre-emergence herbicides and soil insecticides.

Modern corn hybrids, with proper seed care and seed treatment, have a lot of "get up and grow." As the trend toward earlier planting continues,

however, corn breeders need to screen germ plasm more closely for uniform germination and growth under cold, unfavorable growing conditions and for frost tolerance. Plant pathologists must meet this challenge by studying diseases that develop under these conditions. This two-front attack might permit corn and other crops to be planted much earlier than we now assume possible.

PLANT POPULATIONS AND PATTERNS

Each year, more farmers upgrade their fertility program, select better varieties, and use more chemicals to control weed, insect, and disease pests. These practices allow farmers to consider heavier planting rates. With more crop plants per given area, competition between plants becomes more important. Hence, the current interest being shown in planting patterns. Stringfield (17) commented: "Improved (corn) hybrids have changed our concepts of stands; perhaps now improved hybrids are changing our concept of plant distribution."

The practice of recommending a plant population on the conservative side of the yield plateau has been conditioned by drouth, standability, and harvestability. The last two have lost in importance because of earlier harvests and better-standing varieties. Drouth remains a real threat to heavy plant populations. Yet, earlier plantings, coupled with improved varieties and fertility practices, have not shown the drastic yield reductions for drouthy periods that previously occurred so often in the Midwest.

Evaluations (5, 9, 15, 16, 18) of various row spacings by agronomists at Illinois and surrounding Corn Belt states show that yield increases for narrow rows, when contrasted to normal 40-inch rows, varied from 0 to 25%. Narrow rows simply permit a more even plant distribution and a reduction in interplant competition for moisture, nutrients, and light. This lessening of competition permits greater exploitation of increased planting rates. Such plantings also shade the ground sooner and thereby reduce weed growth and soil-moisture evaporation.

The farmer most likely to benefit from planting in narrow rows can be described as follows: his total acreage of corn and soybeans is large, his corn yields in recent years have exceeded 125 bu/acre, his plant population exceeds 20,000/acre, he practices a high-fertility program, good weed control, and early harvesting, and his present corn growing and harvesting equipment are worn and need replacement.

With most midwestern farmers, the big question now is, "Can I afford to convert to narrow rows?" But as their present equipment wears out and *if* the first four circumstances just listed really apply to them, then the pertinent question is, "Can I afford *not* to convert to narrow rows?"

A change to narrow rows will benefit soybeans more than corn in the north-central states. Research results (3, 4, 6, 13) with this crop show yield increases of 10-20% by narrowing rows. Grain sor-

ghums respond similarly (11, 14). Furthermore, recent reports from Michigan, Illinois, and Canada indicate that higher yields of small grains result from spacing rows closer than the conventional 7- or 8-inch rows.

Although we know that individual plants may be somewhat more etiolated in growth habit when crowded and that there will be less air movement within the crop canopy and, thus, less-rapid diurnal fluctuations of temperature and relative humidity, the extent to which these differences influence plant pathogens is not fully documented.

TILLAGE

In the past 10 years, there has been considerable research with many crops in an area called "minimum tillage." This term has been defined by Larson (12) to be a group of soil-preparation methods for planting in which the number of operations and trips over the field are fewer than in the conventional system of practices. Thus, a better term might be "reduced tillage."

No attempt will be made to discuss in detail various minimum-tillage methods. In recent years, several (including those known as wheel-track, plow-plant, and strip-tillage, or combined tillage and planting methods) have been promoted. Basically, these methods seek to hold tillage operations beyond plowing to a minimum. Reduced tillage between the rows has tended to increase yields at low yield levels and to give approximately the same yields at extremely high levels (12).

Recent tillage work on sloping lands has been concerned with elimination of the plow and simply using strip tillage in the seed-row area. The area between rows is treated with an herbicide to control weeds. This method may ultimately find widespread use on sloping lands as problems relating to stand and chemical effectiveness are solved.

It sometimes seems that tillage is more of an art than a science. One of the difficulties encountered by the agricultural engineer is to obtain an exact description of the optimum seedbed from the agronomist. Most agronomists still believe there is a place for the turning plow. The reason most often advanced is that a loose seedbed with greater porosity will increase water infiltration and aeration and, thereby, speed germination. The second reason is that it destroys whatever plant growth is on top and turns under residues. This makes for fast, easy, efficient planting and cultivation. There are other advantages for burying residues in row-crop farming in humid regions. Residues on top mean a cooler soil and may prevent early planting. Plowing residues under is an advantage from the plant-disease and insect-control standpoint.

In addition to the growing trend by midwestern farmers to reduce tillage operations, there also is interest in "zero tillage," wherein all residue is left on the surface. The possible disease consequences of reduced tillage merit more research by plant pathologists.

WEED CONTROL

Fewer weeds are going to be present within and adjacent to cropped areas in the north-central states. The most recent and spectacular weapon employed by man in his fight against weeds has been the use of chemicals. Ennis et al. (7) compiled an excellent review concerning the impact of chemical weed control on farm-management practices. Although chemical herbicides have not replaced mechanical weed control, their future looks promising. A considerable amount of basic research underway is designed to obtain information on the penetration, absorption, and translocation of selective herbicides and on photosynthesis, respiration, metabolism, and enzyme reactions within the plant and the interaction of these with environmental factors. The persistence and behavior of herbicides in the soil and their effects on subsequent crops are also receiving considerable attention. Many specific weed-control programs in the past have not been fruitful because the life history of different weed species was not thoroughly understood and because little was known concerning their natural chemical stimulators or inhibitors of germination. As more answers to these questions are found, these age-old pests of agriculture will steadily diminish in significance.

This trend has implications in plant pathology. Certain pathogens will have fewer alternative hosts, and individual crop plants will have more vigor and disease resistance when weed competition is removed.

HARVESTING

In no area of crop production in the Midwest has there been greater change than in harvesting. Large "super" harvest machines are now prevalent in many areas and for most crops. These allow earlier and more timely harvests and, when coupled with artificial-drying facilities, generally promote higher yields and better quality. This trend has reduced the direct, and particularly the indirect, losses formerly ascribed to many plant and storage diseases.

FERTILITY

I do not profess to know all the short-term, much less the long-term, disease implications of the present spectacular increase in the use of fertilizers by midwestern farmers. Thus far, farmers have received a fair return for money invested in fertilizers,

as measured by increased yields. But according to present knowledge, leading farmers may be at yield levels at which higher rates of nitrogen, phosphorus, and potassium may not be economically profitable because of other limiting factors; e.g., water or the standing ability and yielding potential of present varieties.

Certain farmers, especially those growing small grains, are presently limited as to just how much nitrogen can be added. Although the yield-response curve may be steep as increments of nitrogen are added, the plateau may not be broad, and the decline may be dramatic with additional rates. Such yield-response curves arise from increased lodging and (or) disease buildup. Such nitrogen-response curves in the Midwest can be changed only when small-grain varieties have better straw strength. The new Gaines wheat variety in the Pacific Northwest or the Benhur wheat variety from Purdue University are excellent examples of varieties with this characteristic. They will respond to high fertility additions that were absolutely impossible on varieties in use 10 years ago. Needless to say, these varieties carry resistance to diseases common in their areas.

There are many challenging questions in the fertility-disease area at high yield levels. For example, corn plants producing at the 150 to 200-bu level have corky, brown tissue appearing in the lowermost internodes. At this writing, neither agronomist nor plant pathologist is sure of the cause, or of how much these same plants might yield without such dead tissue.

CHANGES CONTINUE

Tremendous changes have taken place in Corn Belt agriculture in the last decade, but more are in the offing. In the 1970's, still more pressure will be placed on the individual plant within a population for total yield and for uniformity to facilitate harvest and insure market quality. Plant pathologists and agronomists will be challenged increasingly to protect monospecific cropping systems from plant diseases by cultural, genetic, and chemotherapeutic methods. This will be no easy task, but one demanded by farmers and consumers, and essential to allow the full exploitation of other agricultural technological advances. To the grower, there is an economic necessity to increase production. To the world, there are humanitarian goals that necessitate more total production.

LITERATURE CITED

1. Alderfer, R. B., and R. R. Robinson. 1947. Runoff from pastures in relation to grazing intensity and soil compaction. *J. Amer. Soc. Agron.* 39:948-958.
2. Aldrich, S. R. 1964. Are crop rotations out of date? pp. 7-13. *Proc., 19th Ann. Hybrid Corn Ind. Res. Conf.*
3. Beeson, K. E., and A. H. Probst. 1955. *Purdue Univ. Ext. Bul.* 231. pp. 12-15.
4. Cartter, J. L., and E. E. Hartwig. 1962. The management of soybeans. *Adv. in Agron.* 14: 359-412.
5. Colville, W. L., and J. D. Furrer. 1964. Narrow spacings increase yields. *Neb. Agr. Exp. Sta. Quart. No. 4.* pp. 7-9.
6. Cooper, R. L., and J. W. Lambert. 1965. Narrow row soybeans. *Minn. Farm Sci.* 22:5-7.
7. Ennis, W. B., W. C. Shaw, L. L. Danielson, D. L. Klingman, and F. L. Timmons. 1963. Impact of chemical weed control on farm management practices. *Adv. in Agron.* 15:161-210.
8. Hobbs, J. A. 1953. Replenishment of soil moisture supply following the growth of alfalfa. *Agron. J.* 45:490-493.
9. Hoff, D. J., and H. J. Mederski. 1960. Effect of equidistant corn plant spacing on yield. *Agron. J.* 52:295-297.
10. Hughes, H. D., and E. R. Henson. 1957. *Crop production.* Macmillan Co. New York.
11. Laude, H. H., A. W. Pauli, and G. O. Throneberry. 1955. Crop production. pp. 21-23. In: *Crops and Soils Field Day Report.* Kan. Agr. Exp. Sta. Cir. 323.
12. Larson, W. E. 1962. Tillage requirements for corn. *J. Soil and Water Conserv.* 17:3-7.
13. Pendleton, J. W., R. L. Bernard, and H. H. Hadley. 1960. For best yields grow soybeans in narrow rows. *Ill. Res.* 2(1):3-4.
14. Porter, K. B., M. E. Jensen, and W. H. Sletten. 1960. The effect of row spacing, fertilizer, and planting rate on the yield and water use of irrigated grain sorghum. *Agron. J.* 52:431-434.
15. Sentz, J. C. 1965. Effect of row width on corn production. *Minn. Farm Sci.* 22:3-5.
16. Stickler, F. C. 1964. Row width and plant population studies with corn. *Agron. J.* 56: 438-441.
17. Stringfield, G. H. 1962. Corn plant population as related to growth conditions and to genotype. pp. 61-68. *Proc., 17th Ann. Hybrid Corn Ind. Res. Conf.*
18. Yao, A. Y. M., and R. H. Shaw. 1964. Effect of plant population and planting pattern of corn on water use and yield. *Agron. J.* 56:147-152.

Effect of Intensive Cultural Practices on Soil-Borne and Related Corn Diseases¹

M. G. Boosalis, W. L. Colville, and D. R. Sumner²

ABSTRACT

Stalk rots of corn are generally associated with plant stresses. Many intensive cultural practices in the Midwest and in other corn-producing areas that are aimed at more efficient corn production place great stress on the plant and increase its susceptibility to stalk rot and other diseases. Cultural practices that impose a stress on the crop may be in the form of high soil moisture, very high plant populations, imbalanced fertility, and injuries such as those caused by hail, infectious diseases, and insects. Other factors contributing to a high incidence of stalk rot include large quantities of corn residue left on the soil surface from one season to the next, continuous cropping to corn, and perhaps minimum tillage.

INTRODUCTION

Cultural practices for corn production in the Midwest and in other corn-producing areas have changed significantly in recent years. A continued marked intensification of cultural practices reflects the need to meet rapidly rising production costs and the need to raise more food for a rapidly increasing world population. Although intensive cultural practices have substantially increased corn yields, they have also increased the potential threat of certain soil-borne diseases, as well as of other diseases, which frequently nullify expected gains in grain yield.

This paper discusses some of the intensive cultural practices that relate to soil-borne and other corn diseases. In many instances, the evidence cited here for the relationship of specific intensive cultural practices and corn diseases is based primarily on field surveys, with little or no experimental proof to substantiate our interpretation of the observations. Furthermore, much of the information presented here is based on observations and on experiments made in the irrigated-corn areas of Nebraska where cultural practices are undoubtedly the most intensive and where the incidence of stalk rot is the highest in the Midwest and, perhaps, in the USA. The effects of intensive cultural practices on disease development in the irrigated-corn areas are frequently very pronounced and well defined.

The main objective of this report is to define some of the corn problems associated with intensive cultural practices, in the hope of stimulating more research leading to the solution of these problems. Some of the factors involved in intensive cultural practices relating to corn diseases are irrigation,

plant population, row spacing, planting method, a continuous monoculture of corn, plant residue(s), minimum tillage, and high fertilizer application. All these intensive cultural practices are discussed here with the exception of fertilizer application, which is presented in this symposium by Dr. Dean C. Foley.

IRRIGATION

Soil moisture is purported to be an important factor affecting the development of stalk rot of corn. A good understanding, therefore, of the relationship between soil moisture and stalk rot is important in the Great Plains, where many irrigations are necessary for high yields, and in those corn areas where heavy rainfall occurs during the growing season. Unfortunately, however, our knowledge concerning the influence of soil moisture on stalk rot is meager and fragmentary. Nearly all reports on soil moisture and stalk rot deal with field surveys and experiments involving artificial inoculations with the pathogen(s). There is a dearth of research, other than that involving surveys, on the effect of soil moisture on corn naturally infected with stalk-rot pathogens.

Although reports regarding the influence of soil moisture on the incidence of stalk rot caused by *Gibberella zeae* (Schw.), *Fusarium moniliforme* Sheldon, *Fusarium* sp., and *Diplodia zeae* (Schw.) are contradictory, this is to be expected because the reports, in general, are based on field research in different localities and undoubtedly involve different strains and different combinations of the pathogens. Michaelson (19) stated that, in Minnesota, corn inoculated with *Diplodia zeae* showed more stalk rot on unflooded than on flooded land in a season with ample rainfall. Furthermore, Minnesota researchers (3) have repeatedly noted more premature killing of plants inoculated with both *D. zeae* and *G. zeae* by the toothpick method in dry soil than on relatively wet soil of the same field. On the other hand, Melhus and Durrell (18),

¹Published with the approval of the Director as Paper No. 2174, Journal Series, Nebraska Agricultural Experiment Station.

²Professor, Department of Plant Pathology, Professor, Department of Agronomy, and Research Assistant, Department of Plant Pathology, University of Nebraska.

McNew (17), and Koch and Murwin (15) stated that high soil moisture is conducive to stalk rot incited by *D. zeae*, *G. zeae*, and *Fusarium* sp. A more detailed account of the relationship of soil moisture and temperature to stalk rot of corn and sorghum is presented by Christensen and Wilcox (3).

The recent findings of Sumner (28) shed new light on the effect of soil moisture on stalk rot of corn resulting from natural and artificial inoculation in the greenhouse and in the field. This research was concerned primarily with stalk rot caused by *F. moniliforme*, *Cephalosporium* sp., and *Trichoderma viride* Pers. Corn was grown in the greenhouse in pots containing loam or silty clay loam soil. The soils were watered sufficiently to sustain plant growth without stress until tasseling when one of three moisture levels was maintained. The first moisture level was between normal moisture capacity (NMC) and saturation, another was between NMC and half the available moisture capacity (AMC), and a third was between half AMC and the permanent wilting capacity (PWC). One experiment was in a cooler greenhouse (temperature mean 22C, range 8-41C) and the other in a warmer greenhouse (temperature mean 27C, range 16-42C). All plants were grown in the warmer greenhouse 30-37 days; then half were transferred to the cooler greenhouse. Plants grown at the mean temperature of 27C matured and were harvested in 112-116 days after planting, and those at 22C were mature and harvested in 119-121 days. Roots from low-moisture treatments were heaviest and showed very little rotting (table 1). Symptoms of root rot were more pronounced and abundant on plants grown in saturated soils. Furthermore, more pink root decay incited by *F. moniliforme* was noted with plants grown in loam than in silty clay loam soil with both the low-moisture and saturated

treatments. A substantially higher percentage of the isolations from stalks of plants grown in high-moisture soils yielded stalk-rot fungi than did isolations from stalks of corn grown in low-moisture soils (table 1). There was also more stalk rot in plants grown in the saturated soils of both the silty clay loam and the loam soils (table 2). This was true in all Sumner's studies (28), whether plants were grown from seed naturally infected with *F. moniliforme*, or *Cephalosporium* sp., or both, or from uninfected kernels.

Sumner (28) also reported from greenhouse studies that isolations from corn grown on a loam soil from irrigated fields of central Nebraska yielded more stalk-rot fungi than did corn grown on a silty clay loam obtained from a dryland corn field in southeastern Nebraska. Moreover, stalks from plants grown on the loam soil yielded *Trichoderma viride*, a stalk-rotting fungus not detected in plants from the silty clay loam soil. As with other stalk-rot fungi, more stalks were infected with *T. viride* at the higher moisture levels. Sumner (28) speculated that the more acid loam soil, pH 5.9-6.2, contained greater populations of *T. viride* than did the silty clay loam soil, pH 6.4-6.7, thereby providing greater inoculum potential and a more favorable soil environment for initial infection of corn. Also, more plants grown in saturated soil were infected with *F. moniliforme* than were plants from the lower moisture levels of both soil types (28). This helps to explain the preponderance of stalk rot caused by *F. moniliforme* in the irrigated corn areas of Nebraska and other high-moisture areas of the Midwest. More root and stalk-rot fungi were found in higher-yielding plants than in lower-yielding or sterile plants approximately 110-120 days after planting. Sumner (28) also noted that pith-condition ratings, as outlined by Pappelis and Smith (22), were not significantly different at any

TABLE 1. Root weights and percentage of stalk isolations yielding stalk-rot fungi of plants grown on two soil types at three moisture levels in both warm and cool greenhouses (1965-1966).

Experiment	Hall loam			Sharpsburg silty clay loam		
	Saturation	NMC ^a	1/2 AMC ^b	Saturation	NMC	1/2 AMC
	Root wt (g)					
Fall 1965 ^c	7.6	7.9	14.1	7.1	9.2	14.4
Spring 1966 ^d	6.2	13.6	13.6	9.0	14.8	13.0
Spring 1966 ^e	6.4	9.9	10.4	5.4	11.2	11.8
Av.	6.7	10.5	12.7	7.2	11.7	13.1
	% of total isolations yielding stalk-rot fungi					
Fall 1965 ^c	17.3	34.3	12.6	31.5	4.9	15.4
Spring 1966 ^d	34.6	14.1	21.7	19.2	19.2	2.5
Spring 1966 ^e	12.8	5.1	7.7	11.5	3.8	11.5
Av.	21.6	17.8	14.0	20.7	9.3	9.8

^a NMC = normal moisture capacity.

^b AMC = available moisture capacity.

^c Mean of 11 plants, temperature unrecorded.

^d Mean of 6 plants, mean temperature 27 C.

^e Mean of 6 plants, mean temperature 22 C.

After: D. R. Sumner. 1968. The effect of soil moisture on corn stalk rot. *Phytopathology* 58:761-765.

moisture level on either soil. Tissues in plants grown at the highest moisture level, however, appeared to die somewhat earlier. The constantly higher percentage of infections in the crowns and lower nodes and internodes in Sumner's (28) studies indicated that initial infection is *via* the base of the plant.

In 1966, studies were made in Lincoln, Neb., to determine the effect of soil moisture on corn stalk rot in field plots with plant populations from 19,600 to 24,400 plants per acre (28). The heavily irrigated plots were maintained near or above field capacity, receiving a total of 50 inches of water during the season. The control plots received approximately 25 inches of water. Plants in the irrigated plots matured approximately 1 week earlier, and they yielded more grain and showed more stalk rot than the control plots (table 3). Ears from irrigated plants had more infected kernels than did ears from control plots. The incidence of stalk rot on Sept. 8 was 10% on the irrigated plots and 2% on the control plots and increased to 23% and 9% by Oct. 15 on the irrigated and control plots, respectively.

In other field experiments made by Sumner (28) in cooperation with the Department of Agricultural Engineering at the University of Nebraska, corn

grown on irrigated soil kept near field capacity or above had 16% stalk rot compared with 8% stalk rot when soil moisture was kept between 50% field capacity and field capacity. In another experiment, irrigated corn showed 8% stalk rot, whereas un-irrigated corn of the same variety in the same field had only 4% stalk rot.

Although research is lacking to explain why high stalk rot incidence is associated with corn grown on high-moisture soil, several theories can be formulated to explain this phenomenon. The high yields in response to high soil moisture may deplete nutrients in the roots and stalks, resulting in greater susceptibility of these organs to soil-borne pathogens. Since corn matures earlier in high soil moisture, it would be susceptible to stalk-rot organisms longer than would corn grown in lower soil moisture if both the high- and low-moisture corn were harvested at the same time. High soil moisture might also result in anaerobic conditions or in the production of toxins that could predispose the plant to root and stalk rot. More research is urgently needed to ascertain how and why the level of soil moisture influences stalk rot. The results from Sumner's (28) research suggest that stalk rot of corn in Nebraska may be alleviated by proper irrigation. The development of improved irrigation practices based on studies encompassing soil-borne disease problems should provide information to enable proper irrigation for the highest corn yields without incurring heavy yield losses from dropped ears or broken, rotted stalks.

TABLE 2. Comparisons of percentage of stalk rot of corn grown in the greenhouse on Sharpsburg silty clay loam and Hall loam at three different moisture levels.^a

Soil	Moisture level	Stalk rot %
Sharpsburg silty clay loam.....	Saturation	26
NMC ^b	12
½ AMC ^c	6
Av.	15
Hall loam.....	Saturation	20
NMC	17
½ AMC	10
Av.	15

^a Mean of three experiments.

^b NMC = normal moisture capacity.

^c AMC = available moisture capacity.

After: D. R. Sumner. 1968. The effect of soil moisture on corn stalk rot. *Phytopathology* 58:761-765.

TABLE 3. Comparisons of grain yield and percentage of stalk rot of 501D corn grown on irrigated and nonirrigated Sharpsburg silty clay loam in the field.^a

	Yield of grain (bu/acre)			Stalk rot %
	On fallen stalks	On standing stalks	Total	
Irrigated	15	121	136	23
Nonirrigated ^b	2	109	111	9
LSD 0.05.....	17	15	21	20

^a Mean of four replications.

^b Irrigated three times during June and July drought. After: D. R. Sumner. 1968. The effect of soil moisture on corn stalk rot. *Phytopathology* 58:761-765.

CORN RESIDUE

Management of corn residue in the Midwest, especially in the irrigated areas, is an important practice that may contribute to increased severity of several corn diseases. Root and stalk rot, as well as fungus and bacterial blights, are the main diseases associated with corn residue. One of the primary reasons for the recent increased incidence of these diseases may relate to the large quantity of corn residue allowed to remain relatively undisturbed in the field from the time of harvest until shortly before the next season's corn crop is planted in the same field. Three intensive cultural practices may be increasing the potential of primary inoculum of several pathogens associated with corn residue. These are the practices of monoculture of corn, leaving stalks standing until shortly before planting, and minimum tillage.

A continuous supply of residue in the same field over a period of years from a monoculture of corn probably maintains an adequate and virulent level of inoculum to initiate disease outbreaks during seasons with favorable weather. Although this is generally a common assumption, until recently there has been little proof to corroborate this assertion. Findings from recent investigations (24, 31) with crop rotations in some areas indicated that the incidence of corn stalk rot was the highest in plots continually cropped to corn.

The cultural practice of leaving stalks standing

until spring is followed in many corn areas to prevent wind and water erosion. This operation allows much of the corn residue, such as leaf sheaths, leaf midribs, ear husks, and stalks, to overwinter with little deterioration of the tissues. Furthermore, a substantial amount of corn residue remains on the soil surface after the ground is prepared for seeding by conventional methods. Many fields contain as much as 200 lb. of surface corn residue per acre following conventional methods of planting. An even greater quantity of corn residue—over 500 lb.—is on the ground in fields prepared and seeded by minimum tillage (fig. 1). Currently, minimum tillage is used on approximately 98,000 acres in Nebraska. The acreage farmed by minimum tillage is expected to continue to increase in many midwestern areas.

Essentially, minimum tillage is the least possible manipulation of the soil for satisfactory planting, germination, stands, growth, and yield of a crop (10). Minimum tillage has several advantages over conventional methods. It is less expensive since it requires fewer tillage operations. Frequently, it results in higher seed germination and better stands. As soil moisture is conserved, the soil is warmer, and residue on the surface helps to prevent wind and water erosion. Data from 3 to 5 years of research in several locations in Nebraska showed that yields from minimum-tillage-planted corn were equal to yields from conventionally planted corn (16, 32). Similar results also have been reported from other states. But there is very little research to indicate what effect minimum tillage may have on the incidence of corn diseases. There are no reports of specific comparisons between minimum-tillage and conventional methods with regard to corn diseases.

Results from recent investigations clearly show that the abundant corn residue in fields resulting from the aforementioned intensive cultural practices may be an important source of primary inoculum for several diseases.

Our findings indicate that *Helminthosporium turcicum* Pass., the cause of northern leaf blight of corn, overwinters primarily as conidia on corn residue in Nebraska (2). Residue composed of leaf sheaths, leaf midribs, or ear husks collected from the field in May 1966 had 1,000, 900, and 500 viable conidia of *H. turcicum* per g tissue, respectively. Inoculations with these three kinds of pathogen-containing residue caused a low incidence of northern leaf blight.

One important factor that may contribute to the successful overwintering of the pathogen is the formation of chlamydospores within conidia before and perhaps during the winter (fig. 2). Over 50% of the overwintered conidia associated with residue contained viable, infective chlamydospores. The overwintering of virulent conidia of this pathogen in corn residue, and the regular, early appearance of symptoms of the disease (June 16) in specific areas of Nebraska, generally on the lower leaves of plants in fields with abundant surface corn residue in the spring and early summer, indicate a local source of initial inoculum (2). In all probability, the overwintered conidia on corn residue are the principal source of initial inoculum. A few viable conidia, however, were also detected in field soil collected in May and in field soil infested with conidia in October and stored outdoors until May. The mycelium of this pathogen associated with residue evidently is of little importance in providing initial inoculum. Our preliminary studies (unpublished data) indicate that *Helminthosporium maydis* Nisik & Miyake and *Helminthosporium carbonum* Ullstrup, causing southern corn leaf blight and *Helminthosporium* leaf spot, respectively, may overwinter on stalks underneath the attached leaf sheaths on the nodes and on the inner surface of the leaf sheath as mycelia and conidia. These pathogens also appear to be good saprophytes whose overwintering mycelia produce abundant, vigorous conidia in early spring. The overwintered conidia of these pathogens were pathogenic in greenhouse tests. An epidemic of *Holcus* leaf spot on corn occurred in east-central Nebraska June 14, 1966 (29). The sudden appearance of this disease after a severe wind and rain storm, coupled with an abundance of corn residue on the ground from the previous season's crop, suggested that the inoculum for this epidemic was of local origin. This may be the case since *Pseudomonas syringae* van Hall, the incitant of *Holcus* leaf spot, appears to overwinter in corn residue in Nebraska.

Nyvall and Kommedahl (21) reported that *Fusarium moniliforme* may survive at low temperatures by producing thickened chlamydospore-like hyphae. Using infected tissues from artificially inoculated plants, the researchers showed that survival of hyphae of this pathogen was better at a 30-cm soil depth than above or below that level. These findings strongly suggest that *F. moniliforme* may survive in nature as thick-walled hyphae in corn residue. The significance of this mode of survival is obvious in relation to intensive cultural practices resulting in a continuous and plentiful supply of corn residue and disease development.



Fig. 1. Minimum tillage field at Kearney County, Nebraska, showing over 500 lb. per acre of corn residue on top of the ground after field was planted to corn on May 18, 1967.

PLANT POPULATION DENSITY AND PATTERN

Extensive research has been done in recent years on the effects of plant populations, planting methods, and row spacing on yield of grain. The effects of these intensive cultural practices, which in essence primarily concern plant-population distribution, have also been studied in relation to specific components of yield, such as number and size of ears, kernel weight, plant height, stalk lodging, breaking, etc. Very little of this research, however, relates to corn diseases.

The early research of Colville and co-workers (5, 7) at Nebraska dealt with the relationship of plant population and planting method on grain yield of irrigated corn planted in 40-inch rows and adequately fertilized. In their studies and in studies conducted in other states, drilled corn outyielded both hill-dropped and checked corn planted at their respective optimum populations. Drilled corn at the optimum population of 24,000 plants per acre out-

yielded checked corn at the optimum population of 20,000 plants per acre by 15.9 bu/acre. Hill-dropped optimum population of 16,000 plants per acre yielded 9.0 bu/acre less than the optimum population from drilled corn. They also reported that irrigated corn in 40-inch rows can be drilled at 24,000 plants per acre, or 4,000 plants greater than check-planted corn without yield decreases. This held true even when grain from broken and lodged stalks was discounted. Stalk breakage and lodging at the higher plant populations was greater with drilled corn than with check-planted corn.

The effect of row width, plant population, and irrigation on grain yield has been studied extensively in the Midwest in recent years (6, 11, 23, 25, 26, 27). Most publications on narrow row planting of corn show yield increases ranging from 0 to near 100% (4, 6, 11, 23, 25, 26, 27). With irrigated corn in Nebraska (8), populations of 16,000 plants per acre in 20- and 30-inch rows increased yields

Fig. 2. Chlamydospores within overwintered conidia of *Helminthosporium turcicum*. a-b) (X425) Conidia stained with aniline blue in lactophenol: a) eight-celled conidium; b) conidium with one chlamydospore. c-e) (X875) Nongerminated, unstained conidia showing chlamydospore formation: c) two widely separated cells forming chlamydospores; d) large chlamydospore arising from adjacent cells; e) release of chlamydospores by disintegration of conidial wall. f-k) (X875) Germinated, unstained conidia showing germ tube formation from chlamydospores: g) germ tube exit through lateral region of conidial wall; h) germ tubes from three chlamydospores; k) lateral conidial wall ruptured by germ tube from chlamydospore.
After: M. G. Boosalis, D. R. Sumner, and A. S. Rao. 1967. Overwintering of conidia of *Helminthosporium turcicum* on corn residue and in soil in Nebraska. *Phytopathology* 57:990-996.

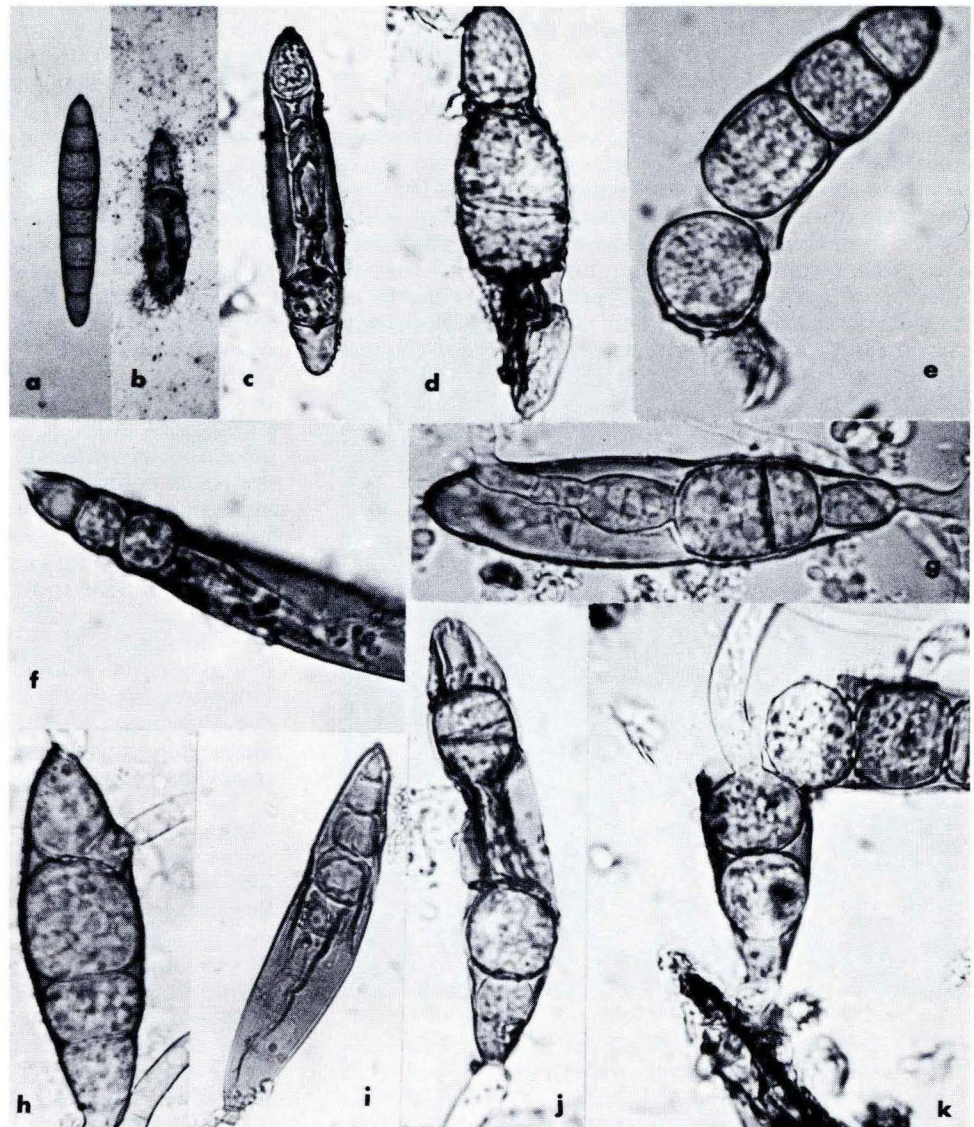

by approximately 15% and 8%, respectively, over yields of comparable populations in 40-inch rows. Populations of 24,000 plants per acre in 20- and 30-inch rows increased yields 24% and 9%, respectively, over that from equal plant populations in 40-inch rows (table 4).

The incidence of stalk rot is greatly affected by row spacing and plant populations (table 5). The amount of stalk rot in 30-inch rows with 16,000 plants per acre was slightly higher than that in 20- and 40-inch rows at this population level. But the percentage of stalk rot in 40-inch rows with 24,000 and 32,000 plants per acre was significantly higher over that in 30- and 20-inch rows with comparable plant populations. The highest percentage of stalk rot in plots with 24,000 and 32,000 plants per acre was noted in the 40-inch rows.

The long-range effect of narrow rows, drilled rows, and high plant populations on disease development cannot be accurately predicted at this time. These intensive cultural practices, however, do affect physical environmental factors, as well as certain morphological characteristics, of the plant that may bear on several aspects of disease development and damage.

Row spacing, plant population, and method of planting have a marked effect on stalk diameter. Studies (5) with hill-planted, checked, and drilled

TABLE 4. Effect of three row spacings and two plant populations on irrigated, drilled corn yields in Nebraska (5 experiments).

Row spacing inches	Plants/A	Bu/A	% Increase over 40-inch rows
20.....	16,000	145	15
.....	24,000	159	24
30.....	16,000	137	8
.....	24,000	140	9
40.....	16,000	126	
.....	24,000	128	

After: W. C. Colville. 1966. Plant populations and row spacings. pp. 55-62. Proc., 21st Ann. Hybrid Corn Ind. Res. Conf.

TABLE 5. Percentage stalk rot of corn as influenced by row spacing and plant population.

Row spacing inches	Plant populations/acre	Mean % 4 replications
20.....	16,000	17.8
.....	24,000	22.6
.....	32,000	29.5
30.....	16,000	20.0
.....	24,000	22.0
.....	32,000	36.0
40.....	16,000	18.1
.....	24,000	28.9
.....	32,000	45.4

After: W. C. Colville. 1966. Plant populations and row spacings. pp. 55-62. Proc., 21st Ann. Hybrid Corn Ind. Res. Conf.

plantings in 40-inch rows of irrigated corn showed a linear decrease of stalk diameter with increasing populations of 12,000 to 28,000 plants per acre. The stalk diameter of drilled corn was significantly (5) greater at these plant populations than that of hill-dropped or checked corn, however. Results from current investigations (unpublished data) with drilled, irrigated corn in narrow rows of 20 and 30 inches indicate that stalk diameter is larger than that of corn in 40-inch rows at all plant population levels (table 6). The larger diameter of stalks in narrow rows with high plant populations compared with those in 40-inch rows may be an important factor in reducing breakage and lodging of plants severely infected with stalk-rot fungi. In this connection, it would be informative to know whether the thickness of the stalk rind is also affected by plant population density and pattern.

It appears that narrow-row-planted, irrigated corn at the higher populations has a finer and better-developed root system than does check-planted corn in 40-inch rows. This comparison is based only on incidental field observations of corn roots. It may be that the more equal distribution of plants resulting from drilled corn plantings provides a better nutritional and physical environment with less competition among plant roots than the checked or hill-dropped plantings. The more vigorous roots of drilled corn, in turn, would more likely contribute to sturdier, larger-diameter stalks, which could better withstand breakage and lodging from diseases. Certainly, more research is warranted on the effect of intensive cultural practices on root development in relation to disease development.

The intensity and kind of light radiation, as well as the amount of leaf area exposed to the light, affect the over-all process of photosynthesis. In the field, the quantity and quality of light reaching a crop are not appreciable influenced by cultural practices. But the amount of leaf surface exposed to light is contingent on the plant population and the spatial distribution of plants within and between the rows (33). Aubertin and Peters (1) reported that corn plants in 20-inch rows absorbed considerably more light energy through spatial distribution of leaf area to incoming radiation. Net radiation

TABLE 6. Effect of row spacing and three plant populations on stalk diameter of irrigated corn in Nebraska.

Row space inches	Population/acre			Mean
	16,000	24,000	32,000	
	Stalk diameter (cm)			
20.....	2.896a ^a	2.523bc	2.464c	2.628a
30.....	2.795a	2.549bc	2.411cd	2.585a
40.....	2.657b	2.441c	2.297d	2.465b
Mean.....	2.783a	2.504b	2.391c	

^a Means in column followed by same letter do not differ significantly (0.01 level of probability) by Duncan's multiple range test.

(i.e., the difference between the incoming and outgoing radiation) at 1 m above the crop surface was usually higher in 42-inch than in 21-inch rows and was higher at 14,000 plants than at 28,000 plants per acre. Plants crowded together in 40-inch rows absorbed much less energy due, in large part, to self-shading. Colville (9) indicated that, of several environmental factors measured, light was the only one affected significantly by planting method (table 7). The quantity of light reaching the level of approximately 30 cm above the soil at populations of 12,000, 16,000, 20,000, 24,000, and 28,000 plants per acre was lower in drilled corn than in hill-dropped and checked, irrigated corn in 40-inch rows. Light reaching this level remained relatively unchanged at populations of 20,000 or more plants per acre for the three methods of planting. The utilization of more light in the upper canopy of drilled corn compared with hill-dropped and checked plantings may explain, in part, the yield advantage of drilled corn (9). Thus, an optimum spatial distribution of leaves resulting from optimum plant population, row spacing, and method of planting should provide a more vigorous plant with greater resistance to soil-borne and other diseases.

The spatial distribution of high corn populations may affect other microenvironmental factors to create conditions favorable for diseases. Colville (9) showed that increasing plant populations up to 20,000 plants per acre with drilled, hill-dropped, and checked corn in 40-inch rows also significantly increased relative humidities and decreased soil temperatures during the day (table 8). The air temperature was relatively unaffected. Furthermore, the evaporative power of the air flow through the drilled canopy was greatly reduced at the higher plant populations (table 8). Wind velocity inside the canopy of a drilled stand of 28,000 plants per acre as compared with that outside the canopy was reduced from 170 to 40 cm/sec. Relative humidity, soil and air temperatures, evaporative power

TABLE 7. Percentage of outside light approximately 30 cm above the soil surface as modified by plant population or method of planting corn (1959-1960).

Plant population	Method of planting ^a		
	Checked	Hill-dropped	Drilled
Outside	100	100	100
8,000.....	39	35	35
12,000.....	30	24	16
16,000.....	18	14	10
20,000.....	13	11	9
24,000.....	12	10	9
28,000.....	12	9	8

Outside 5,400 ft-c

^a Each value an average of 14 observations.

After: W. L. Colville. 1968. Influence of plant spacing and population on aspects of the microclimate within corn ecosystems. *Agron. J.* 60:65-67.

of the air, and air movement were not significantly influenced by planting method. The depression of soil temperature, the evaporative power of the air and air movement, and an increased relative humidity with increased populations of drilled, hilled, or checked corn in narrow rows (unpublished data) could be of paramount importance in creating an environment conducive to fungus and bacterial blights and other foliage diseases. Such an environment also could increase the inoculum potential of several destructive pathogens that reside on or near the soil surface.

DISCUSSION

The success of the current intensive cultural practices, and of those to be developed, for increasing grain yield of corn may depend largely on research aimed at reducing the threat of soil-borne and other diseases associated with cultural practices.

One way of achieving this success is to develop corn hybrids more responsive to intensive cultural practices with regard to high plant populations, drilled planting, narrow row spacing, irrigation, and high fertility. Hybrids adaptive to these intensive cultural practices will more effectively utilize light energy, nutrients, and moisture to produce more vigorous plants resistant to soil-borne diseases, particularly stalk rot of corn, as well as other diseases.

The increased threat of northern leaf blight of corn and other foliage diseases due, in part, to the enormous amount of residue left on the soil surface after planting may be controlled by breeding for resistance to these diseases. The famous gene *Ht* for resistance to northern leaf blight discovered by Hooker (12, 13, 14) should be incorporated into

TABLE 8. Average soil temperature at 5 cm below the soil surface and percentage relative humidity and evaporation at 1 m above the soil surface as influenced by corn plant population at completion of pollination (1959-1960).

Plant population	Soil temperature (C)	Relative humidity	Evaporation cc/24 hrs
Outside	27.8a ^a	60.2a	87.65a
8,000.....	25.3b	76.4b	37.63b
12,000.....	24.2c	77.5c	30.73c
16,000.....	24.0c	78.0cd	27.39cd
20,000.....	23.4d	79.1d	26.15de
24,000.....	23.4d	79.1d	25.65de
28,000.....	23.1d	79.0d	21.47e

^a Means in column followed by same letter do *not* differ significantly (0.01 level of probability) by Duncan's multiple range test. Each soil temperature is an average of 1824 observations. Each air temperature and relative humidity figure is an average of 912 observations.

After: W. L. Colville. 1968. Influence of plant spacing and population on aspects of the microclimate within corn ecosystems. *Agron. J.* 60:65-67.

hybrids developed for areas with intensive cultural practices. Such resistant corn hybrids also would reduce losses from stalk rot, which may be a concomitant of northern leaf blight of corn.

Selection of corn varieties that show healthy roots under environmental stress may be another means of reducing stalk and root rot in areas with intensive cultural practices. Such research is being pursued by Nagle at South Dakota in producing corn lines resistant to stalk and root rot. This could be a very effective means of reducing losses from stalk rot since initial infection in some of these diseases clearly occurs primarily in the roots and subsequently spreads into the crown and stalk (30).

Research on the biochemistry of host-parasite relations undoubtedly will lead to the development of more effective chemotherapeutic agents for the control of soil-borne and other diseases of corn. It appears that a greater number of candidate chemicals will be available for testing against many destructive and refractory soil-borne diseases. Mitchell's (20) intriguing pioneer studies showed that the excretion from roots of chemical compounds applied to the foliage bodes well for the future development of chemotherapeutic agents against soil-borne, root-attacking pathogens. These kinds of chemicals may be effective against stalk and root rot, even though none of the compounds tested by Mitchell (20), such as alphanemethoxyphenylacetic acid, was excreted by the crown roots. It may be, however, that these compounds applied to foliage are translocated in sufficient amount to corn roots to afford protection from within this organ against infection by soil-inhabiting parasites. It is also possible that future research will uncover other compounds excreted by corn roots in protecting them from the outside against attacks by soil-borne pathogens.

It is obvious that not all the current intensive cultural practices are adequate to produce the highest corn yields. Before any current cultural

practice can be modified and before new ones can be devised to secure higher and constant yields, however, it will be necessary first to gain more information regarding the interrelationship of certain environmental factors and yield potential. Thus, more research should be undertaken to determine the optimum soil-moisture level in relation to plant density and distribution for maximum yields. Our knowledge concerning the effect of temperature and soil moisture on soil-borne diseases and yield potential is also very meager. The effect of different levels of soil moisture at different stages of plant development in relation to stalk-rot severity is not clearly understood. Another area of research that should be more extensively pursued to produce more vigorous and higher-yielding plants concerns soil fertility with regard to population density, row spacing, and water utilization efficiency of plants at different fertility levels.

Improvement of equipment may reduce further losses from corn diseases due to harvest delay and difficulties. More efficient picker shellers, corn combines, and especially drying equipment would permit earlier and faster harvesting to reduce losses from stalk and ear rot that become destructive when the grain is not harvested immediately after it reaches the proper moisture level.

Crop rotations have given good control of stalk rot of corn in experimental plots in some areas (24, 31). Further research is needed to ascertain whether these crop rotations are effective against the disease in commercial fields, especially in areas with diversified crop production. It would appear, however, that crop rotation will not be adequately perfected for the control of many soil-borne diseases until we know a great deal more about the ecology of these parasites in the soil.

These are some of the problems that should be resolved to devise more efficient intensive cultural practices to minimize losses from diseases and to maximize grain yield of corn.

LITERATURE CITED

1. Aubertin, G. M., and D. B. Peters. 1961. Net radiation determinations in a corn field. *Agron. J.* 53:269-272.
2. Boosalis, M. G., D. R. Sumner, and A. S. Rao. 1967. Overwintering of conidia of *Helminthosporium turcicum* on corn residue and in soil in Nebraska. *Phytopathology* 57:990-996.
3. Christensen, J. J., and R. D. Wilcoxson. 1966. Stalk rot of corn. *Phytopathology Monograph No. 3*. Heffernan Press, Inc. Worcester, Mass. 59 p.
4. Collins, E. V., and C. K. Shedd. 1941. Results of row spacing experiments with corn. *Agr. Eng.* 22:177-178.
5. Colville, W. L., and D. P. McGill. 1962. Effect of rate and method of planting on several plant characters and yield of irrigated corn. *Agron. J.* 54:235-238.
6. _____, and O. C. Burnside. 1963. Influence of method of planting and row spacing on weed control and corn yields. *Trans. Amer. Soc. Agr. Eng.* 6:223-225.
7. _____, A. Dreier, D. P. McGill, P. Grabouski, and P. Ehlers. 1964. Influence of plant population, hybrid, and "productivity level" on irrigated corn production. *Agron. J.* 56:332-335.
8. _____. 1966. Plant populations and row spacings. pp. 55-62. *Proc., 21st Ann. Hybrid Corn Ind. Res. Conf.*
9. _____. 1968. Influence of plant spacing and population on aspects of the microclimate within corn ecosystems. *Agron. J.* 60:65-67.
10. Free, G. R. 1960. Minimum tillage for soil and water conservation. *Agr. Eng.* 41:96-99.
11. Hoff, D. J., and H. J. Mederski. 1961. Effect of equidistant corn plant spacing on yield. *Agron. J.* 53:43-45.
12. Hooker, A. L. 1961. A new type of resistance in corn to *Helminthosporium turcicum*. *Plant Dis. Rptr.* 45:780-781.
13. _____. 1963. Monogenic resistance in *Zea mays* L. to *Helminthosporium turcicum*. *Crop Sci.* 3:381-383.
14. _____. 1963. Inheritance of chlorotic-lesion resistance to *Helminthosporium turcicum* in seedling corn. *Phytopathology* 53:660-662.
15. Koch, L. W., and H. F. Murwin. 1945. The hybrid corn industry in Ontario; pathological and other problems. *Empire J. Exp. Agr.* 13:100-111.
16. Lane, Delbert E., and Howard Wittmus. 1961. Nebraska till plant system. *Neb. Agr. Ext. Circ.* 61-714. 8pp.
17. McNew, G. L. 1937. Crown infection of corn by *Diplodia zeae*. *Iowa Agr. Exp. Sta. Res. Bul.* 216.
18. Melhus, I. E., and L. W. Durrell. 1922. Dry rot of corn. *Iowa Agr. Exp. Sta. Circ.* 78.
19. Michaelson, M. E. 1957. Factors affecting development of stalk rot of corn caused by *Diplodia zeae* and *Gibberella zeae*. *Phytopathology* 47:499-503.
20. Mitchell, John W. 1963. Perspectives of biochemical plant pathology. The symposia and lectures commemorating the 75th Anniversary of the Department of Plant Pathology and Botany. *Conn. Agr. Exp. Sta. Bul.* 663.
21. Nyvall, R., and T. Kommedahl. 1966. Thickened hyphae as a survival mechanism in *Fusarium moniliforme* (abstract). *Phytopathology* 56:893.
22. Pappelis, A. J., and F. G. Smith. 1963. Relationship of water content and living cells to spread of *Diplodia zeae* in corn stalks. *Phytopathology* 53:1100-1105.
23. Pendleton, J. W. 1965. Cultural practices-spacing, etc. pp. 51-58. *Proc., 20th Ann. Hybrid Corn Ind. Res. Conf.*
24. Richardson, J. K. 1942. Studies on root rot of corn in Ontario. *Can. J. Res.* 20:241-256.
25. Rossman, E. C., and R. L. Cook. 1966. Soil preparation and date, rate and pattern of planting. pp. 53-101. In: W. H. Pierre, S. R. Aldrich, and W. P. Martin (eds.). *Advances in corn production: principles and practices*. Iowa State University Press, Ames. 476 pp.
26. Shaw, R. H. 1961. The effect of plant population and planting pattern of corn on radiation interception and water use. Final Report. U. S. Weather Bur. Iowa State University, Ames.
27. Stickler, F. C. 1961. Row width and plant population studies with corn. *Agron. J.* 56:438-441.
28. Sumner, D. R. 1968. The effect of soil moisture on corn stalk rot. *Phytopathology* 58:761-765.
29. Weihing, J. L., and Anne K. Vidaver. 1967. Report on Holcus leaf spot (*Pseudomonas syringae*) epidemic on corn. *Plant Dis. Rptr.* 51:396-397.
30. Whitney, N. J., and C. G. Mortimer. 1957. Root and stalk rot of field corn in southwestern Ontario. I. Sequence of infection and incidence of the disease in relation to maturation of inbred lines. *Can. J. Plant Sci.* 37:342-346.
31. Williams, L. E., and A. F. Schmitthenner. 1963. Effect of crop rotation on yields, stalk rot and root rot of corn. *Phytopathology* 53:1412-1414.
32. Wittmus, H. D. 1959. Minimum tillage method can cut costs. *Neb. Exp. Sta. Quart. Spring Issue.* pp. 3-5.
33. Yao, Augustine Y. M., and R. H. Shaw. 1964. Effect of plant population and planting pattern of corn on the distribution of net radiation. *Agron. J.* 56:165-169.

Structural Design Aspects of Corn Stalk-Rot Damage Under Intensified Fertilizer Usage¹

by D. C. Foley²

ABSTRACT

The cornstalk lodging problem has not been solved by using improved hybrids, possibly because changes in production methods have worsened stalk rot severity. All commercial hybrids have stalks which, if considered as vertical cantilever beams, are strong enough to support a grain crop many times the weight now being produced. Because of stalk decay, however, susceptible hybrids lose most of their inherent stalk strength as measured by breaking loads. Soil fertilization and population density appear to influence stalk rot severity, but the changes are minor in relation to the total amount of decay. Breeding for stalk rot resistance has much potential as a way to reduce lodging.

INTRODUCTION

Consequences of the heavier fertilizer applications used in modern agriculture are valid concerns of plant scientists. Any disease that threatens the structural integrity of heavily fertilized crop plants is a major problem because the increased yields critically load the weakened structural supports.

Stalk rot of corn (*Zea mays* L.) is not a new problem; rotted and lodged stalks were common when open-pollinated varieties were grown. The introduction of hybrid corn brought with it plants of improved standability. Probably the greatly increased stalk-rot resistance of hybrids was instrumental in making mechanical harvesting possible. Nevertheless, observations of corn fields at harvest and lodging percentages from corn-yield tests show that standability continues to be a problem. This is cause for concern, particularly because many years of effort have been devoted to improving standability of hybrids. Although there is little doubt that hybrids have been improved in stalk-rot resistance, the problem of lodged corn is not receding with the use of better hybrids, as would be expected.

Concurrent with the use of better hybrids have been changes in production methods. It is pertinent and timely to inquire if these changes are influencing stalk-rot severity. More specifically, are certain cultural practices increasing stalk-rot severity, thus negating the advantage of genetically improved hybrids? In any event, the consequences of increased fertilizer usage in relation to disease must be anticipated. What will happen to corn

culture if stalk-rot severity, now barely tolerable, increases? Yields are being pushed higher than considered possible 25 years ago. Will a yield ceiling be imposed by stalk rot? This is not a rhetorical question. The answer could influence the direction of corn-disease research.

A logical and simple approach is to isolate some of the mechanical factors to be surmounted and then to evaluate possible solutions. In 1966, the average corn yield in Iowa was about 78 hl/ha (90 bu/acre). Even though this was favorably received by farmers, it was rather poor considering the potential. But, if because of stalk rot, producing an average of 78 hl/ha is creating lodging problems at harvest, with most stalks barely able to stand and a substantial number lodging, what is going to happen when this average yield is doubled?

Let us examine some possible consequences of increased yields. Assume that the use of improved hybrids, favorable moisture conditions, and copious quantities of fertilizer result in a 174 hl/ha (200 bu/acre) crop. How strong do stalks have to be to support such a yield? A purpose of this discussion is to consider the structural aspects of supporting such production.

WEIGHT AND DISTRIBUTION OF CORN YIELD

Weight of grain before moisture loss must be considered. When a farmer sells 174 hl of corn, he is paid for approximately 12,550 kg, but unfortunately, this is not what the grain weighed while it was still on the plants. Taking a moisture content of 40% at 60 days after mid-silk, assuming this as the maximum dry-matter accumulation date, the ears including husks may weigh over 24,600 kg. Stalk rot generally is first evident at 60 days; thus, this date can be considered a critical time. The

¹Journal Paper No. J-5846 of the Iowa Agriculture and Home Economics Experiment Station, Ames, Iowa. Project No. 1575.

²Associate Professor of Plant Pathology, Iowa State University, Ames, Iowa.

weight of the ear slowly decreases with maturity.

The weight distribution also needs to be considered. There are several ways to distribute 24,600 kg of corn, which brings us to a variable partly under control of the producer, although the limits may be rather narrow. One would get 24,670 kg of corn if he grew a 0.416-kg ear on each of 59,300 plants; another combination might be a 0.500-kg ear on each of 49,300 stalks. A 0.500-kg ear of corn may seem huge; nevertheless, ears over 0.363 kg are not uncommon now. For example, a crop yielding 109 hl/ha (125 bu/acre) at harvest may have weighed over 0.389 kg/ear average if produced on 39,500 stalks. Today, the optimum plant population is being determined empirically, and it probably will continue to be. But, when thinking of stalk rot and its effects, we want to know whether it is easier to support a given load in small units with many stalks or in larger units on fewer, but larger and presumably stronger stalks.

STALK STRENGTH CHARACTERISTICS

Breaking Strength

Before the preceding question can be answered, something needs to be known of the strength of stalks. Strength has several characteristics, depending on the stress being applied. Let us examine the characteristic known as "breaking strength." This is determined by loading the stalk until it breaks. Although the method has certain limitations, breaking strength represents the ability of a stalk to support a load applied slowly for a short time.

The machine I use measures the force required to break a 16-cm section of a cornstalk treated as a simple beam with midpoint loading. Since the total forces about the member must equal zero, the bending moment at any given section can be calculated (Appendix). If a force of 100 kg is exerted at the midpoint, then each support is exerting 50 kg, and the maximum bending moment at the center is 4.0 kg-m. Stalks tested in this manner reveal that strength depends on the hybrid, year (to some extent), stalk size, and date of measurement (figs. 1 and 2).

All hybrids tested have strong stalks in August, and some hybrids (e.g., B14 x C103) often maintain this strength until October. But most hybrids (e.g., Hy x L317, Hy x 38-11, and WF9 x L317) begin to lose strength in late August or early September. Sometimes, even resistant hybrids lose strength. For instance, in 1958 at Kanawha, Iowa, in corn plots with severe stalk rot, stalks of B14 x C103 had lost almost all their strength by October. It is quite clear that the loss of strength that occurs in many maturing plants is due to tissue decay, whatever the cause of decay may be.

Breaking-strength information can be applied to standing stalks by considering stalks as vertical cantilever beams. If a bending moment of 0.75 kg-m at the second internode breaks the stalk, then a total load of 0.75 kg concentrated at a distance 1 m from the second internode will create the same

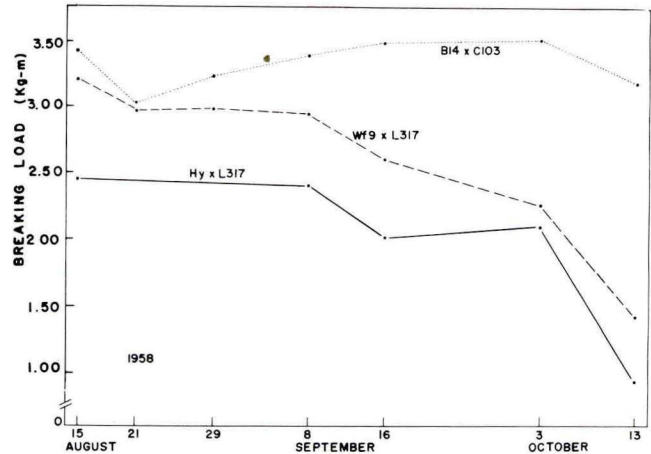

Fig. 1. Force required to break 16-cm internode sections of cornstalks. The stalks were measured at the second internode above the brace roots by the loading shown in fig. A-4.

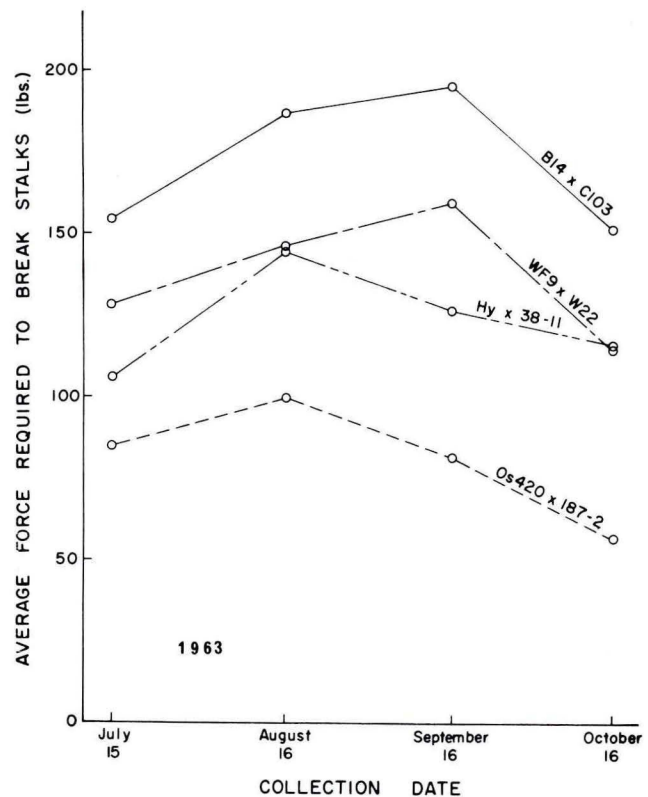

Fig. 2. Force required to break 16-cm internode sections of cornstalks grown in 1961. From: R. W. Ikenberry and D. C. Foley. 1967. Cellulase activity in cornstalks infected with *Fusarium moniliforme* Sheld. and its relation to stalk rot. Iowa State J. Sci. 42:47-61.

bending moment, and the stalk should break. Or if the load is uniformly distributed along the stalk, then a load of 0.463 kg/m of stalk will create a bending moment of 0.75 kg-m at a point 20 cm above the base of a 2 m stalk.

If we assume a uniformly distributed load of 1.85 kg/m on a 2-m stalk, then a bending moment of 3.00 kg-m is created at a point 20 cm above the stalk's base. This is equivalent to the force created when 75 kg are applied to the test sections, and most stalks tested in August are able to bear this load at the second internode. Even in October, some unrotted stalks did not fail when a bending moment of 4.50 kg-m was applied.

By measuring the strength of unbroken stalks being loaded near their maximum capacity, such as rotted stalks, a crude estimate of the field loading can be obtained. That is, if a rotted stalk takes a force creating 0.75 kg-m to break its second internode, then the total field load, however distributed, must have been such that the bending moment created was less than 0.75 kg-m at the second internode—or the stalk would have broken. Preliminary measurements indicate that the average field load (incorporating wind and ear weight) creates less than 0.75 kg-m bending moment at the second internode. Even with this conservative estimate, it is clear that the stalk can support a load much greater than 0.75 kg-m at the second internode, *provided* that some way can be found to prevent the strength loss caused by rotting that occurs in September and October.

Of course, stalks in the field do not have a uniformly distributed load, nor do they have a single concentrated load. Wind can be thought of as exerting against the stalk a force that gradually decreases toward the free end. Added to this force would be smaller loads concentrated at the leaf-sheath bases. To my knowledge, the loads applied by wind to cornstalks have not been measured. Since wind is not nominally under control of management, wind loads can be considered an ever-present factor important in all production practices.

Forces created by the ear also are complex. Forces transmitted from the ear to the basal area of the stalk create stresses dependent on a) ear weight and b) distance between the ear and the neutral axis of the standing stalk. The greater the degree of bending of a stalk by wind, the greater is the load created by a given ear weight, and therefore, the greater are the stresses created at the base of the stalk.

Since cornstalks are long in relation to their sectional dimensions, they break because of bending rather than because of compressive stress. It takes over 7 kg/cm² to cause failure of an axially loaded stalk-rind section. Thus, the compression caused by the downward thrust of a 0.45-kg (1 lb.) ear of corn can be disregarded. Furthermore, the loading caused by the ear obviously is not axial. In slender structures, failure can occur due to bending or buckling at a fiber-stress level lower than the failure stress of the material. Analysis of the buckling strength of columns is based on the state

of equilibrium created when the axial loading is exactly that which will keep the column in its deflected shape after a lateral force is removed. This load is defined as the critical load (P_{cr}). It can be visualized that, when the critical load is exceeded, lateral deflection keeps increasing until the column buckles. In 1757, Euler derived a formula for the analysis of behavior of long slender columns. For a column having one end fixed and the other end free to rotate and to move, which describes a cereal stalk, the critical load is given by $P_{cr} = \pi^2 / (2L)^2 \times EI$, where L is length and I is the second moment of area of the cross section. The effects of both shape and size are incorporated into I .

Use of this formula requires a knowledge of the modulus of elasticity (E), commonly called Young's Modulus. Determination of this basic mechanical property has not been made with the proper instruments; thus, confidence in its accuracy is lacking. Investigation of the flexural rigidity (EI) of cornstalk tissue is necessary to understand and predict stalk lodging under given experimental conditions.

The Euler formula is of interest because it shows how to increase load capacity and thereby reduce lodging. As can be seen, the critical load is not dependent on the breaking strength of the material, but is proportional to its EI and inversely proportional to the square of the length of the load-carrying number; height is more important than stiffness. Another inference is that, for greater stability, the material (rind, culm, etc.) should be distributed as far as possible from the neutral axis so that I becomes maximum for a given amount of material. Reducing the rind thickness and increasing stem diameter can only be carried so far, lest the wall fail because of wrinkling. It can be seen why rind thickness *per se* may be a relatively ineffective way to increase load capacity.

It is possible that cornstalks may deviate significantly from the ideal model because of their large diameter. Adjustments thus will have to be made. The formula should, however, be useful in the analysis of lodging of other cereals.

By using the most conservative estimates and calculations, it is clear that an unrotted stalk has a built-in safety factor that may be as high as 10. This safety factor, however, is completely negated in a badly rotted stalk. Clearly, if stalk decay could be controlled, or even partly retarded, stalks would be strong enough to support several times the ear weight imposed by a 174 hl/ha yield.

Stalk Size

Are there avenues other than reduction of stalk rot that might be used to increase stalk strength at harvest? Strength measurements of sound unrotted stalks show a relation between strength and stalk size (August measurements, fig. 3). If the average breaking strength is plotted against stalk diameter, the slope of the regression line is approximately the same at different plant densities of a given hybrid (fig. 4). Increasing stalk size appears

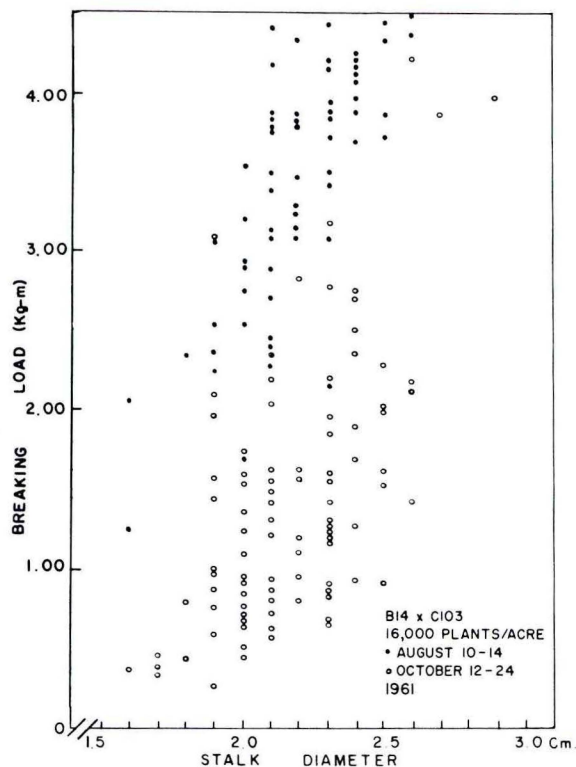

Fig. 3. Scattergram showing relation of breaking load to stalk size.

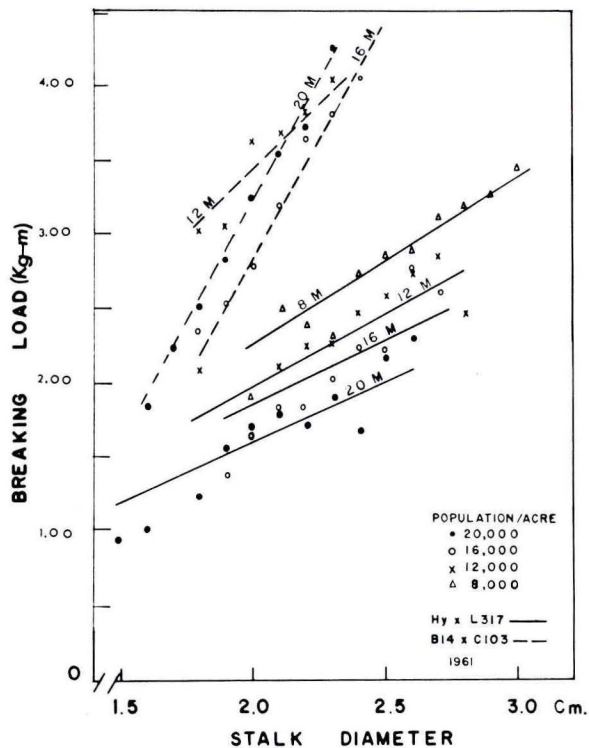

Fig. 4. Relation of cornstalk strength to size in two hybrids at various populations. The graph was drawn from a series of scattergrams of which fig. 3 is one example.

of limited potential as a means of increasing stalk strength of a given hybrid. Furthermore, there is no assurance that stalk decay will not be greater in larger stalks, thus offsetting the effect of the increased quantity of tissue. Little or no relation of stalk size to strength is discernible in rotted or partly rotted stalks (October measurements, fig. 3). Evidently, the larger stalks at a given plant density have no advantage in resisting the effects of decay. Thus, increased size obtained by the use of higher fertility levels cannot be expected to be a large factor in directly increasing stalk strength.

Fertility

Perhaps fertility is more important because of its secondary effects. Fertilizing practices have been studied from this viewpoint, but the measurements have been on gross effects. For example, nitrogen supplementation has been observed to increase stalk lodging. Was the increased lodging due to inherently weaker stalks, increased decay, increased loading by the greater ear weight, or due to a combination of these factors? The contribution of each factor can be appraised more accurately by the application of design mechanics. This requires knowledge of specific mechanical properties.

One limitation in the measurement of stalk-rot severity has been the lack of criteria for the degree of damage inflicted. This is particularly true of the insidious, nearly symptomless, phase of disease—the most common form encountered. Changes in mechanical properties of stalk tissue are potentially useful in the measurement of decay affecting stalk strength.

Abney (1) measured the influence of nitrogen and potassium fertilization on stalk diameter, rind thickness, and stalk-breaking strength. He found that, in August, when the stalks were presumed undamaged by stalk rot, nitrogen increased diameter, but not breaking strength of the stalk. Thus, the stalks were actually weaker per unit of cross-sectional area. The amount of this difference depends upon whether the stalks are considered as circular beams or as cylinders with only the rind bearing the induced stresses. Since nitrogen increased the yield, there was a greater load imposed on stalks of the same strength, but the influence of nitrogen on stalk-rot severity was not so clear. According to pith-condition ratings, nitrogen increased stalk rot, but strength differences in October attributable to nitrogen were not evident.

Potassium fertilization increased stalk size, and a greater load was required to break the stalks (1). The potassium effect occurred under conditions in which potassium did not give highly significant yield increases. Thus, it is possible that the effect of potassium on inherent stalk strength might be more pronounced in soils more deficient in potassium. The greater strength of stalks from potassium-fertilized plots persisted until at least 60 days after the mid-silk date, but there was no stalk strength advantage of the potassium-fertilized plants when they were measured after frost in October. Possibly, the commonly observed beneficial effect of

potassium fertilization on stalk-rot severity operates by reducing or retarding the rate of decay during a critical period before death of the host plant. Further studies of mechanical properties will help to interpret the effects of decay in stalk-rot and fertility experiments.

DISEASE RESISTANCE

Knowledge of mechanical properties may have additional utility in breeding for disease resistance. Stalk strength has been used for many years as a criterion of selection. Rarely are ears from weak, broken stalks retained during inbreeding. Refined measurements (expressed per unit area) of mechanical properties have potential use in the identification of inbred lines having factors that may reduce decay severity when used in a hybrid combination, but which appear weak as inbreds because of small cross-sectional area. Any aid in the development of decay-resistant lines is welcome because, of all the factors that determine stalk strength at harvest (and, thus, the ability to bear

a given load), the decay factor has the greatest influence. Other factors become important if they influence stalk-rot severity. In this respect, the effect of fertility is not clear. I know of no instance in which a particular fertilizer treatment controlled stalk rot. Calculations and experimental results show that stalks are almost completely rotted before failure occurs. A slight reduction in decay could minimize stalk lodging. Thus, further adverse effects of fertility may have been overemphasized. A start has been made in separating the various components of the fertility effect.

Even though nitrogen decreases strength per unit of cross sectional area, it does not appear that intensive fertilizer usage will necessarily result in disastrous consequences. The approach that promises the greatest potential for increasing stalk strength at harvest (thereby reducing the problem of lodged corn) is the development of lines that, in hybrid combinations, reduce stalk decay. The analysis of structural design should aid in the understanding and development of such superior hybrid combinations.

BIBLIOGRAPHY

1. Abney, T. S. 1967. Influence of nutrition on stalk rot development of *Zea mays* L. Ph.D. thesis. Iowa State University. 99 pp. (Mic. 67-12, 940, Univ. Microfilms, Ann Arbor, Mich.)
2. American Institute of Steel Construction. 1963. The manual of steel construction. 6th Ed. New York. 432 pp.
3. Black, P. 1966. Strength of materials. Pergamon Press. New York. 454 pp.
4. Ikenberry, R. W., and D. C. Foley. 1967. Cellulase activity in corn stalks infected with *Fusarium moniliforme* Sheld. and its relation to stalk rot. Iowa State J. Sci. 42:47-61.
5. Marin, J. 1962. Mechanical behavior of Engineering materials. Prentice Hall, Inc. Englewood Cliffs, N. J. 298 pp.
6. Timoshenko, S. P. 1956. Strength of materials. Part II. 3rd ed. Von Nostrand. Princeton. 240 pp.

APPENDIX

The cornstalk, for strength analysis, can be considered a vertical, tapered cantilever beam of circular section, connected by a rigid joint at the base. A rigid joint may transmit both a simple force and a couple. The stalk is assumed in equilibrium; therefore, the algebraic sum of the components of all forces in each of two mutually perpendicular directions in the plane of the forces must equal zero.

$$\Sigma F = 0$$

Cantilever Beam with Single Concentrated Load

Consider a stalk AB (fig. A-1) of length L , rigidly attached at A, and with a force W exerted at O. Consider the stresses acting at XX, which is a distance b from A, and also those stresses at A, the point of attachment.

The weight or force W is creating two stresses, a force (shear) acting perpendicular to the beam, and also a couple tending to rotate the stalk in a clockwise direction (bending moment). The bending moment (M) is usually the important factor in determining whether a beam will break.

For any section XX, the bending moment is a function of x ; i.e., proportional to the distance from the origin. Therefore,

$$M_x = Wx$$

Its graph (fig. A-1,b) is thus a straight line OP. At the stalk base, where x is equal to L , the bending moment is WL and is clearly the maximum bending moment (M_{max}).

Cantilever Beam with a Distributed Load

The force acting at XX is the weight acting against the portion x . This acts at a distance $x/2$.

$$M_x = wx(x/2) \text{ or } (w/2)x^2$$

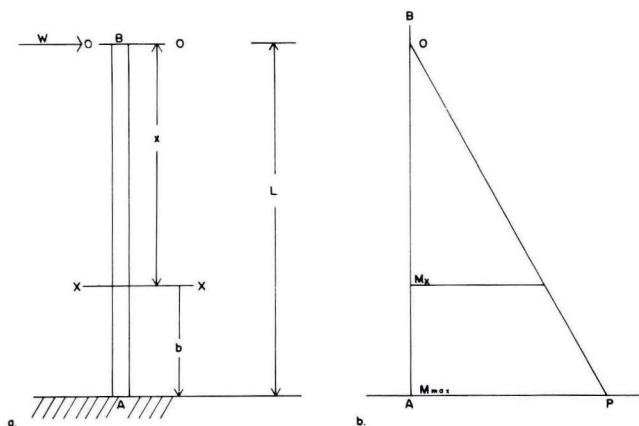

Fig. A-1. Diagram of cantilever beam with single concentrated load.

If the loaded portion x is the same as the stalk length (L), then maximum bending moment is $wL^2/2$ and, since wL is the total load (W), then:

$$M_{max} = WL/2 \text{ (or } -WL/2, \text{ if counterclockwise)}$$

As can be seen (fig. A-2,b), the graph of the bending moment against x is thus a parabola (BP).

Cantilever Beam with Several Concentrated Loads

Since the value of M at any section is the sum of moments of all forces occurring above the section,

$$\begin{aligned} M_1 &= W_1(L_1 - L_2) \\ M_2 &= W_1(L_1 - L_3) + W_2(L_2 - L_3) \\ M_3 &= W_1L_1 + W_2L_2 + W_3L_3 \end{aligned}$$

Thus, the graph of M is a series of straight lines (fig. A-3,b).

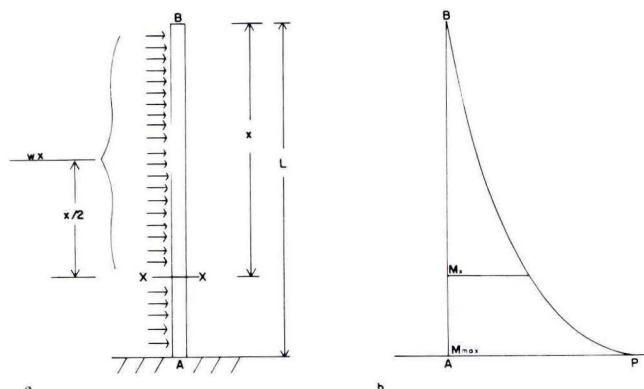

Fig. A-2. Diagram of cantilever beam with a distributed load.

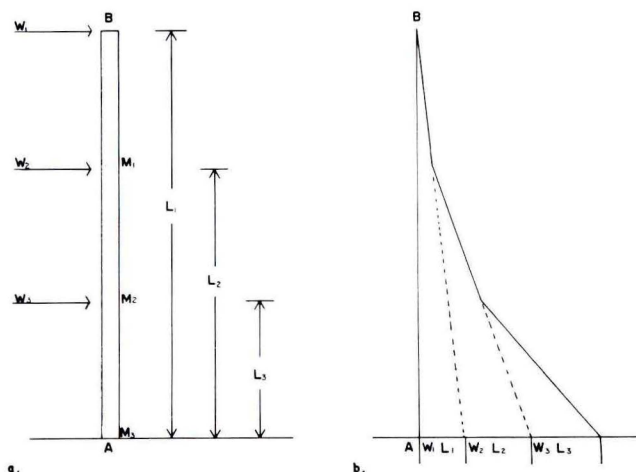

Fig. A-3. Diagram of cantilever beam with several concentrated loads.

Maximum Bending Moments in a Stalk Treated as a Simple Beam with Midpoint Loading

Since $\Sigma F = 0$, obviously, the force exerted by W at the center is counteracted by the supports R_1 and R_2 and is divided equally between them (fig. A-4). Thus, $R_1 = W/2$. At any section x to the left of the load

$$M_x = W/2x \text{ as long as } x < L/2$$

Thus, M is proportional to the distance x from the lefthand support, and the graph of M is a straight line. The bending moment at either R_1 or R_2 is zero, and at the center of the beam, where $x = L/2$, $M_{max} = W/2 \times L/2 = WL/4$

This is the maximum bending moment, in a simple beam with midpoint loading.

In any section Y to the right of the load, $M_y = W/2y - W(y-L/2) = W/2(L-y)$

Slender Columns

The Euler formula is the basis for the analysis of slender members, such as columns and struts. Assumptions include (a) that the material obeys Hooke's law within the range of the load and (b) that direct compressive stress is unimportant in failure. Consider a long column (fig. A-5,a) of length L that has both ends free to rotate but not to move laterally (hinged) and that is loaded axially until equilibrium is reached (it remains in the bent shape when a small lateral force is removed).

By use of the differential equation for flexure of members of uniform bending stiffness

$$EI(d^2y/dx^2) = +M = -Py$$

$$\text{or } (d^2y/dx^2) + Py/EI = 0$$

$$(d^2y/dx^2) + k^2y = 0 \text{ when } k = P/EI$$

Thus, $P = k^2EI$

It can be shown that $kL = \pi$ or $k^2 = \pi^2/L^2$

Since $P = k^2 \times EI$

$$P_{cr} = \pi^2/L^2 \times EI \quad (\text{i.e., the Euler formula})$$

If one end of the column is fixed by a rigid joint so that it cannot rotate and the other end is free to move, the column becomes a vertical cantilever beam (fig. A-5,b), which is equal to half of the double-hinged column of (fig. A-5,a). Therefore, the critical load is given by $\pi^2/(2L)^2 \times EI$; thus

$$P_{cr} = (\pi^2EI/L^2)/4$$

If one incorporated the weight of the stalk above the ear into the loading P , then an additional bending moment will be created. This means that the field critical load may be less than that predicted by the Euler formula. Also, the relatively large diameter in relation to height of cornstalks could result in the outermost fibers being stressed beyond the elastic limit, giving an experimental critical load significantly below theoretical. Stems of other cereals (oats, wheat, etc.) should be much closer than corn to theoretical values.

Formulas for second moments of area of the cross section (I) for a variety of shapes can be obtained from handbooks; e.g., American Institute

of Steel Construction (2). If the cereal stalk is considered a cylinder, then $I = \pi d^4/64$. On the other hand, if the rind is considered the structural element and is assumed circular, $I = \pi(d_1^4 - d_2^4)/64$. Most cornstalks are nearly ellipsoidal, and if the neutral axis corresponds to the major axis $I = \pi ab^3/4$, the rind I is found by total, minus pith. For a given cross-sectional area, there can be many diameters and rind thicknesses, and they will have different I values. Thus, the flexural rigidity (EI) of cereal stalks can vary because of different I values.

Obviously stalks or stems cannot be designed in the engineering sense, but a knowledge of design principles is necessary in understanding the lodging behavior of crop plants. These design principles can be obtained from a number of elementary texts. Black (3) and Marin (5) are especially clear and illustrate many useful examples. Timoshenko (6) is a comprehensive source of specific information and is widely quoted in the literature.

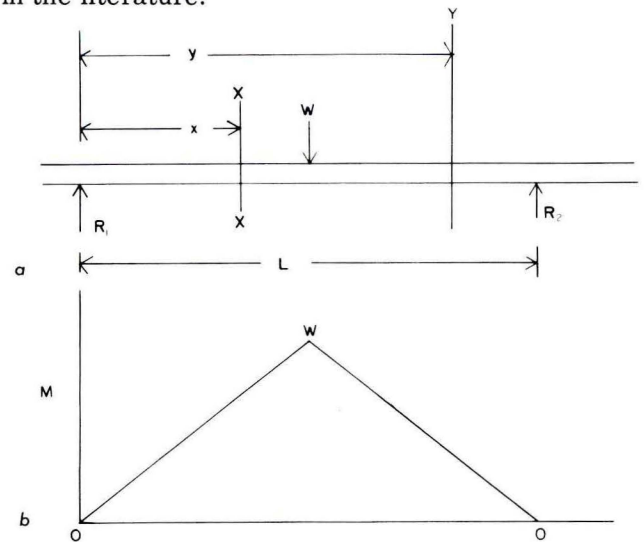

Fig. A-4. Diagram of a simple beam with midpoint loading.

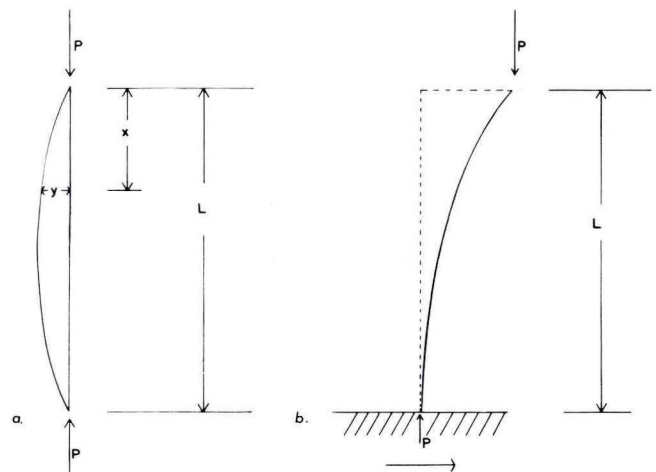

Fig. A-5. Diagram of a slender column under axial loading.

Widely Based Resistance to Rust in Corn

by A. L. Hooker¹

ABSTRACT

Corn rust, caused by *Puccinia sorghi* Schw., is an endemic disease on corn in the Western Hemisphere. *P. sorghi* has the potential of developing in epiphytotic proportions, and almost all conditions needed for the development of epiphytotics occur in the Corn Belt. Corn rust, however, is not an economic disease in the Corn Belt, presumably because of some form of plant resistance. Many major dominant genes have been identified for resistance to *P. sorghi*. These genes occur in the form of many alleles at six or more loci and condition a race-specific type of resistance. These dominant genes, for the most part, are not used in commercial corn hybrids grown in the USA. A mature plant type of resistance, which is polygenic in inheritance, however, is prevalent in most commercially grown corn. This resistance is believed of a generalized type. Widespread use of diverse sources of mature-plant resistance is believed the predominant reason that corn rust is a minor disease in the Corn Belt. More intensive and extensive culture of corn is not expected to increase the severity of rust infection in corn that cannot be overcome by host resistance, but ill-conceived corn breeding efforts and the unwise production of susceptible hybrids might result in disease losses.

INTRODUCTION

Common corn rust, caused by *Puccinia sorghi* Schw., is distributed throughout the world wherever corn is grown. In the Western Hemisphere, where corn rust is an endemic disease, corn and *P. sorghi* have undergone co-evolution.

Corn rust, as do other cereal rusts, has the potential of developing in epiphytotic proportions, and almost all conditions needed for the development of epiphytotics are present in North America. Vast acreages of corn are grown in the Corn Belt of the USA and southward into Central America. Most corn plants are susceptible to rust in the seedling stage. The rust fungus is usually present each year in the Corn Belt. Many biotypes or physiologic races occur (10, 21, 37). Although the alternate host, *Oxalis* spp., is commonly found, it rarely is infected in the USA. In Mexico, however, the alternate host rusts heavily each year (1). *P. sorghi* is believed to overwinter in southern regions of the North American continent and to spread northward each spring and summer.

The fungus has a high reproductive capacity, but no exacting environmental requirements. Urediospores are released readily from the uredium and dispersed widely by the wind. In the presence of free moisture, urediospores germinate over a wide range of temperatures.

Environmental conditions favorable to corn rust vary from year to year and from location to location. In certain seasons local epiphytotics may

occur (4, 41). Infection may be heavy, particularly on susceptible sweetcorn or on susceptible dent-corn inbreds and hybrids. Severe infection is commonly seen on corn in seed-production fields or in breeding nurseries, even when surrounding fields of commercial corn are little damaged. Severe epiphytotics of the disease can be induced artificially in susceptible corn if spreader rows are inoculated early in the season (10, 31).

ECONOMIC IMPORTANCE

In some parts of Africa and Europe, corn rust frequently damages the commercial crop, but in the USA, the disease is of minor economic importance. It is interesting to speculate on reasons for this phenomenon. Because of continuous corn culture from Central America and other southern regions into the Corn Belt, the fungus has a ready means of northward spread each year. This is evident from the lack of an alternative means of overwintering in the North and because races of *P. sorghi* in the USA are similar to those in Mexico (21). Thus, the overwintering and dispersal characteristics of *P. sorghi* are similar to those of other cereal-rust fungi.

It is conceivable that tall, widely spaced corn plants provide a less favorable environment for rust fungi than do short, densely spaced oat and wheat plants. Yet, corn rust develops extensively in certain corn fields of the Corn Belt. By using nearly isogenic resistant and susceptible corn hybrids for comparison, yield losses in the magnitude of 6.3 to 23.5% have been measured (10, 31).

¹Professor of Plant Pathology and Genetics, Department of Plant Pathology, University of Illinois, Urbana, Illinois.

In years when rust is prevalent on susceptible corn, most dent-corn hybrids are relatively rust free. This suggests that some form of resistance must be functioning.

TYPES OF RESISTANCE

Resistance in corn to *P. sorghi* is of two types, a) specific resistance and b) generalized resistance. Both have been studied experimentally in our laboratory and elsewhere.

Specific resistance is expressed in the seedling stage in the form of chlorotic or necrotic flecks. Sometimes small pustules are surrounded by chlorotic tissue. Other resistant infection types occur. Specific resistance is expressed after the host and pathogen have made intimate contact (7). It is based upon host plant hypersensitivity, is qualitative in expression, and is clearly race specific. A plant may be highly resistant to certain *P. sorghi* biotypes or races but fully susceptible to others. If a plant is resistant to a rust biotype in the seedling stage, it probably is resistant to this same biotype throughout the remaining plant stages. Some corn genotypes express resistance to a large number of *P. sorghi* biotypes, whereas others express resistance to only a few biotypes (9).

Generalized resistance is usually seen in the field and is expressed by the mature plant. This mature-plant type of resistance is expressed in the form of a low number of rust pustules on the plant and is quantitative in expression. A continuous range may be seen, from the highly resistant plant with few pustules to the highly susceptible plant with most of the leaf surface covered with pustules. Individual pustules usually are large and produce many spores. A given corn genotype reacts similarly in different years when exposed to rust inoculum in the field. If susceptible, it will always show a large number of pustules; if resistant, a low number of pustules. Because of this and because the natural inoculum comprises many races, the mature-plant type of resistance, based on percentage of leaf area infected, is believed of a generalized type and to function against most, if not all, biotypes of *P. sorghi*.

Specific Resistance

A large number of sources of specific resistance are known. Mains, Trost, and Smith (24) in the mid-1920's reported resistance in several sweet-corn, popcorn, and dent-corn varieties. By empirically screening corn inbred lines and open-pollinated varieties from many parts of the world, over 100 sources of resistance expressed in the seedling stage have been located (9, 14, 18). In addition to corn, specific resistance also is expressed by teosinte and by *Tripsacum* (25). We have found no open-pollinated corn variety uniformly homozygous for rust resistance genes. The frequency of plants with specific resistance in a variety is usually low, but may be high. Usually, only one major gene for rust resistance has been found in each variety or inbred line. This is particularly true for resis-

tance that is dominant in inheritance. If resistance is recessive in inheritance, however, resistance may depend upon several genes interacting in various ways.

The inheritance of specific resistance has been studied extensively (6, 10, 11, 16, 17, 20, 22, 23, 26, 32, 42). Mains (22, 23) was the first to show that this type of resistance could be due to a single dominant gene. One of these genes, in inbred GG208R, was shown through a cytological study to be located on the distal one-fourth of the short arm of chromosome 10 (29, 30). This location has been confirmed through the use of chromosome translocation stocks (33). This gene, in GG208R, was first designated as *Rp* (29), later as *Rp*¹ (32), and more recently as *Rp*₁^a (11). Subsequent genetic studies of other resistant corn lines from various regions of the world have shown the existence of a large series of alleles at this locus (6, 16, 20, 32, 42) (table 1).

Recent work has shown that some of the "alleles" at the *Rp*₁ locus are very closely linked genes or pseudoalleles. In these studies, a line carrying one allele was crossed with a line carrying another presumed allele, and the resulting F₁ was crossed with a homozygous susceptible tester. Large

Table 1. Genes for resistance to *Puccinia sorghi* identified from various sources.

Gene	Source	Country
<i>Rp</i> ₁ ^aGG208R, G. Glow, G. King, 777	USA
<i>Rp</i> ₁ ^bB38, B216, B217	USA
<i>Rp</i> ₁ ^cK148, B. Y. Dent, Syn. A.	USA
<i>Rp</i> ₁ ^dCuzco	Peru
<i>Rp</i> ₁ ^dKitale, Njoro	Kenya
<i>Rp</i> ₁ ^eB49	Argentina
<i>Rp</i> ₁ ^fPI 172332	Australia
<i>Rp</i> ₁ ^gPI 163558	Guatemala
<i>Rp</i> ₁ ^hGuanajuato 29-157A	Mexico
<i>Rp</i> ₁ ⁱPI 163558	Guatemala
<i>Rp</i> ₁ ^jQueretaro VI 366	Mexico
<i>Rp</i> ₁ ^kQueretaro V 231-5	Mexico
<i>Rp</i> ₁ ^lPI 163558	Guatemala
<i>Rp</i> ₁ ^mPI 163563	Guatemala
<i>Rp</i> ₁ ⁿBZU-20	Yugoslavia
<i>rp</i> ₂13b	USA
<i>Rp</i> ₃ ^a25	Australia
<i>Rp</i> ₃ ^bM16	Australia
<i>Rp</i> ₃ ^bE697	South Africa
<i>Rp</i> ₃ ^cNN14	Australia
<i>Rp</i> ₃ ^dLeon I 27-4-1	Mexico
<i>Rp</i> ₃ ^eHidalgo 3-5-1	Mexico
<i>Rp</i> ₃ ^fPI 251653	Yugoslavia
<i>Rp</i> ₄ ^aQueretaro V 260-1	Mexico
<i>Rp</i> ₄ ^bPI 193906	Ethiopia
<i>Rp</i> ₅PI 186191	Uruguay
<i>Rp</i> ₆PI 172597	Turkey

populations of these testcrosses were evaluated in greenhouse seedling tests to detect genetic recombination for disease reaction. In the first series of experiments (34), a single rust culture avirulent on both resistant parents was used. In this testing scheme, only susceptible recombinations could be detected. A susceptible seedling, however, could also result from a gene mutation or from a chromosomal deletion. Therefore, an estimate of the occurrence of these phenomena was obtained by testing the F_1 of a resistant inbred x a susceptible inbred for disease reaction. A statistical test was employed to determine if the frequency of susceptible seedlings in the testcross was significantly different from the frequency of susceptible seedlings in the check employed to estimate the number of susceptible seedlings that might result from the combined effect of mutation and chromosomal deletion. Recombinations of 0.27% and 0.40% were found between Rp_{1^a} and Rp_{1^k} and between Rp_{1^s} and Rp_{1^l} , respectively. The crosses Rp_{1^d} x Rp_{1^k} and Rp_{1^a} x Rp_{1^d} also were tested, but the frequencies of susceptible seedlings in the testcrosses were not significantly different from those of the check.

In a more recent experiment (35), rust cultures giving reciprocal reactions on the two resistant parents in the testcross were available. By using a mixture of two cultures, it was possible to identify both the susceptible and resistant recombinants in a testcross. The phenotypes of these rare plants were confirmed by inoculating detached leaf sections with each culture separately. The rare plants also were saved for seed production and progeny testing. Both resistant and susceptible recombinations in a 1:1 ratio were detected in the testcross of Rp_{1^c} x Rp_{1^k} . The recombination value was calculated to be $0.17\% \pm 0.04\%$ at the 95% confidence interval. The phenotypes of the recombinants have been confirmed in progeny tests.

Other genes for rust resistance also occur on chromosome 10. Locus Rp_5 , first identified in corn line 191 from Uruguay, is linked to Rp_1 by about 1.1 ± 0.2 crossover units. Locus Rp_6 in corn line 597 from Turkey is linked to Rp_1 by about 2.1 ± 0.4 crossover units and to Rp_5 by about 3.3 ± 0.6 crossover units. Thus, Rp_1 must be situated between Rp_5 and Rp_6 (6, 42). In addition to these three genes for resistance to *P. sorghi*, gene Rpp_9 for resistance to *P. polysora* Underw. is on chromosome 10 and is linked to Rp_{1^d} by about 1.6 crossover units (39).

Dominant genes for resistance to *P. sorghi* also occur on chromosomes 3 and 4 (33, and A. L. Hooker and W. A. Russell, unpublished data). Locus Rp_3 is on chromosome 3. This locus was first identified in a series of Australian inbred lines (11). Corn lines from South Africa, Mexico, and Yugoslavia also have single dominant alleles at this locus (42) (table 1). The genes at Rp_3 in the Australian inbreds NN14 and M16 exhibit a reversal of dominance to two biotypes of *P. sorghi* (17). Either gene Rp_3 exhibits a dosage effect or closely linked dominant and recessive genes occur at or near this locus in these resistant lines. Locus Rp_4 is on chromosome 4. Corn lines from Mexico (6)

and from Ethiopia (42) have alleles at this locus. Allele Rp_{4^b} in line 906 from Ethiopia expresses a Z reaction type to *P. sorghi* (40). In this reaction type, the young leaf sections, especially those sections still chlorotic and just emerging from the leaf whorl at the time of inoculation, are rust susceptible, but the older distal area of the leaf is resistant, as are all the older leaves.

In addition to dominant genes, recessive genes for resistance are also known (10, 26). Resistance may be due to one, two, or three recessive genes in a corn inbred line. In inbreds Amargo 47 and Midland 125, high resistance is conditioned by the complementary effect of three recessive genes at independent loci (26). One of these genes in the dominant state always conditions a susceptible reaction. A second gene when in the dominant state also conditions a susceptible reaction except when the third gene is in the dominant state and the first gene is in the recessive state. The third gene conditions an intermediate reaction except when the first gene is present in the dominant state. It is obvious from results obtained in genetic studies of other resistant lines that various forms of gene interaction for rust resistance occur.

The existence of modifying genes for resistance to *P. sorghi* has been detected in several studies (20, 26, 42). Nearly isogenic lines, each with different major genes for resistance, have been developed by backcrossing, selfing, and selection (15). The highly susceptible inbreds B14 and R168 are the recipient (recurrent parent) lines. Frequently the recipient lines and the donor line (nonrecurrent resistant parent) differ slightly in rust reaction, although both carry the same major gene for rust reaction. The importance of modifying factors is not known. By intercrossing recipient and donor lines having common major genes for rust resistance, it should be possible to study the segregation of modifier genes in the absence of any segregation of the major gene.

Many sources of specific resistance to *P. sorghi* have not been studied adequately in inheritance tests. It is evident, however, from the backcrossing program employed in the development of nearly isogenic lines (15) that many of the unstudied sources have single dominant genes. Enough work has been done, however, to demonstrate that a large number of loci and alleles for rust resistance exist in corn. The genes frequently function as single genes, but may interact in various ways. They occur on at least four chromosomes. Some loci are closely linked.

Generalized Resistance

Many Corn Belt inbred lines express a mature-plant type resistance to *P. sorghi* (8, 10, 13). In 1953, a natural epiphytotic of corn rust was present in the dent-corn breeding nursery at the Iowa Agricultural Experiment Station. Four hundred five established inbreds, including many obsolete lines, were rated in the field for rust reaction (8) (table 2) by using the rating scale of Peterson, Campbell, and Hannah (28). In retrospect, either

the epiphytotic was mild or the ratings were conservative because no rating was higher than 40. Susceptible inbreds frequently have ratings as high as 70. It is clear, however, that a large proportion of the lines was highly resistant to rust. When 160 of the field-resistant lines were tested in the greenhouse in the seedling stage to 18 separate rust cultures, most of the lines were susceptible (8). The lines that showed no resistance in the seedling stage but that were relatively rust free in the field in 1953 also were relatively rust free in inoculated field plots in 1954.

The inheritance of mature-plant resistance to *P. sorghi* was studied over a 3-year period (10, 12, 13) in the field at Urbana, Ill. Parents and segregating F_2 populations of 5 susceptible x susceptible, 15 resistant x resistant, and 44 resistant x susceptible crosses were used in the study. Plots consisted of 10 plants each. All plots pertaining to a cross were together, but in a random order. Spreader rows were inoculated with a mixture of *P. sorghi* biotypes, and the fungus was allowed to spread naturally into the test plots. Late in the season, while the plants were still green, approximately 100 plants of each segregating population and 10 plants of each nonsegregating population were scored individually for percentage of leaf area infected. Four crosses were advanced to the F_3 generation and scored for rust reaction on the basis of a progeny row from each F_2 plant.

Wide variation in rust reaction was observed among plants in the F_2 generation. The variation ranged from the rust scores of one parent to those of the other parent. Sometimes rust scores of individual F_2 plants exceeded the parental scores. Variation among plants in the F_2 generation of each cross was continuous, and the frequency distribution of individual plant scores approximated a normal distribution. Most F_2 plants had scores near the population mean. The mean score of each F_2 population was near the calculated average of the two inbred parents. The mean score of the F_1 generation of each cross usually was between that of the F_2 and that of the most resistant parent. This may be an indication of partial dominance for resistance. On the other hand, it may be a manifestation of heterosis.

Table 2. Frequencies of inbred lines with various ratings for mature-plant reaction to rust at Ames, Iowa, in 1953.

Rating ^a	Frequency
0.....	9
Tr.....	92
1.....	99
5.....	113
10.....	69
20.....	19
30.....	3
40.....	1

^aPercentage of leaf area infected.

The results from the F_2 generation were supported by data from the F_3 generation. Individual progenies more resistant or more susceptible than either parent were obtained.

Variation among plants in the inbred and F_1 generation usually was quite small. This indicates that the intensity of rust infection throughout the test plot was quite uniform and that most of the variation among plants in segregating populations can be attributed to genetic differences.

Heritability (H) values were calculated by the following three methods:

- (1) $H = [s^2F_2 - (s^2P_1 + s^2P_2 + s^2F_1)/3]/s^2F_2 \times 100$
- (2) $H = [s^2F_2 - (s^2P_1 + s^2P_2)/2]/s^2F_2 \times 100$
- (3) $H = (s^2F_2 - s^2F_1)/s^2F_2 \times 100$

The methods differ only in the type of nonsegregating parent populations employed to obtain an estimate of environmental variance. The heritability estimates for method 1 ranged from 17% to 98% and averaged 84.3% for the 64 crosses. For method 2, the range was 13% to 100%, and the average was 86.5%; for method 3, the range was -23% to 100%, and the average was 80.0%.

These data indicate that many, but perhaps not a large number, of genes condition mature-plant resistance to corn rust. They further indicate that it should not be difficult to select for mature-plant resistance in a breeding program. It is evident that a high degree of this type of resistance has been fixed in a number of corn inbred lines. These inbreds contribute a high degree of resistance to their hybrids.

PRESENT SITUATION IN THE CORN BELT

Puccinia sorghi is prevalent but not damaging in the Corn Belt. Numerous physiologic races exist, but no attempt is made to identify them or to determine their prevalence. Corn breeders and pathologists have no significant testing program for rust resistance, and rust resistance is not an important objective in USA corn-breeding programs. Although many inbred lines are used to produce commercial hybrids in the Corn Belt, only a few lines and their modified versions are used widely. These popular lines form the basic genetic structure of commercial hybrids. Less widely used lines contribute genetic diversity to the crop.

Several major dominant genes for rust resistance are effective in the Corn Belt. Lines with gene Rp_1^d from Peru (table 1) have been exposed to infection by *P. sorghi* throughout the Corn Belt for several years. In addition, many rust cultures have been collected and used in greenhouse tests (14). Up to this time, plants with gene Rp_1^d have been universally resistant. In 1966, numerous back-cross-derived lines of the rust-susceptible inbred R168, each with a different major gene for resistance to *P. sorghi*, were grown in the nursery at Urbana, Ill. (table 3). Several rust biotypes were introduced into the nursery by inoculation of other plants, but some naturally occurring biotypes also were present. Plants were rated for percentage of

leaf area infected near the end of the season. Eight of the dominant genes conditioned good resistance. Plants with nine of the dominant genes, however, showed as much infection as the rust-susceptible inbred R168.

Although many dominant genes for specific resistance have been identified, they are relatively rare in the commercial hybrids of the Corn Belt. Among all the widely used inbred lines, I know of only one with resistance expressed in the seedling stage. In addition to this line, the highly susceptible inbred B14 is being replaced rapidly with inbred B14A, which is a backcross-derived selection of B14 with rust resistance gene Rp_1^d incorporated into it (15, 31). All the other lines are susceptible in the seedling stage.

Many widely used inbred lines have various degrees of mature-plant resistance to rust. Most are moderately to highly resistant. Only a few popular lines are highly susceptible.

I believe that the extensive use of numerous inbred lines with mature-plant resistance is the primary reason that corn rust is not an economic disease in the Corn Belt. Rust infection is kept at a continually low level. There is little or no selection for virulent races of the pathogen that are capable of developing in epiphytotic proportions on plants with only specific resistance.

FUTURE PROJECTION FOR THE CORN BELT

It is my view that the prevalence and intensity of corn rust will be influenced only slightly by more intensive and extensive corn culture. The incidence of rust infection may be increased by narrow-row

Table 3. Rust reactions of mature plants of inbred R168 and of backcross-derived lines of R168 each containing a different dominant gene for resistance to *Puccinia sorghi* (Urbana, Ill.), 1966.

Gene	Rating *	Gene	Rating
R168- rp^+50	Rp_3^a20
Rp_1^a50	Rp_3^b50
Rp_1^b 5	Rp_3^c20
Rp_1^c50	Rp_3^d50
Rp_1^dTr	Rp_3^e35
Rp_1^e30	Rp_3^f50
Rp_1^f 5	Rp_4^a50
Rp_1^gTr	Rp_4^b35
Rp_1^h40	Rp_515
Rp_1^iTr	Rp_650
Rp_1^j50	$Rp\ddagger$ 5
Rp_1^kTr	$Rp\ddagger$50
Rp_1^l35	$Rp\ddagger$30
Rp_1^m35	$Rp\ddagger$Tr

* Percentage of leaf area infected.

† Susceptible inbred R168.

‡ Locus and allele not identified.

spacing and higher plant populations because these cultural practices provide a more favorable environment for disease development. To reduce mutual shading among plants in dense populations, future hybrids may be selected for a more upright leaf-growth pattern. Such plants are expected to rust less heavily than plants with more decumbent leaves (12). Higher fertility levels, in my opinion, should enhance resistance rather than result in plants with greater susceptibility. Since *P. sorghi* does not overwinter in the Corn Belt, continuous corn culture should have little influence on rust development. Early planting should result in plants escaping rust inoculum until later stages in plant development, thus decreasing the intensity of infection and degree of damage. If inoculum is present, sprinkler irrigation would enhance infection. More extensive corn culture could favor disease, but distance between corn fields at present does not appear to constitute a barrier to the spread of this airborne pathogen. Considering all factors, changes in future corn-culture practices are not expected to create a rust-disease problem that cannot be solved by host resistance.

The replacement of double-cross hybrids with single-cross hybrids productive at high plant population levels will reduce genetic diversity in the commercial crop. I believe that this reduction in genetic diversity is potentially dangerous. Fortunately, many inbred lines that tolerate crowding also have an adequate degree of mature-plant resistance to rust. But, if corn breeders and seed producers take a complacent attitude toward corn rust and put a highly susceptible corn single-cross into production, the disease could do considerable damage. Such hybrids, however, would be taken out of production rapidly and replaced by hybrids with more resistance. Fortunately, there is adequate genetic diversity for this to be done. Corn Belt farmers can be provided with a wide selection of suitable hybrids without the use of susceptible material.

Specific resistance could be used, if needed, as a supplement to mature-plant resistance. Specific resistance conditioned by major genes has not been exploited for corn in the Corn Belt. Although it is doubtful that permanent resistance can be developed by using specific resistance alone (4, 12, 27), several major genes in corn are known that now condition good resistance in the Corn Belt. In addition, recombinations between closely linked genes may permit development of plants with broader ranges of specific resistance (12, 35). The availability of many dominant genes for specific resistance, genetic diversity among corn inbred lines, and the hybrid nature of the commercial crop afford an easy opportunity to explore the multiline approach of Borlaug (2, 3). Genetic diversity for resistance has been cited as an important factor limiting corn rust in Mexico (2). Various other workers have stressed the importance of genetic diversity and widely based resistance in disease control in other crops (4, 5, 12, 19, 36, 38).

Tolerance to rust has not been studied adequately in corn. Tolerance probably exists in corn,

however, as it does in some other crops (12). If needed, tolerance could be used to reduce disease damage in future corn hybrids.

The most promising means of keeping corn rust a disease of minor importance in the Corn Belt, in my opinion, is to continue use of the generalized form of resistance that has proved so effective in the past. Higher levels of this form of resistance are possible and may be needed in fields where high populations of plants are grown. A testing program for mature-plant rust resistance should

be a part of every corn-breeding program. Whenever detected, very susceptible corn-inbred selections should be discarded from the breeding program. Because of the genetic diversity in corn, this can be done without sacrificing progress on other breeding objectives. Through the practice of using generalized resistance extensively and specific resistance only sparingly, it should be possible to consistently contain the rust population at a low level in the Corn Belt and to continue to keep corn rust a minor disease.

REFERENCES CITED

1. Borlaug, N. E. 1964. *Puccinia sorghi* on corn in Mexico (abstract). *Phytopathology* 36:395.
2. _____. 1959. The use of multilineal or composite varieties to control airborne epidemic diseases of self-pollinated crop plants. pp. 12-26. In: First Int. Wheat Genet. Symp. Proc., Winnipeg.
3. _____. 1965. Wheat, rust, and people. *Phytopathology* 55:1088-1098.
4. Caldwell, R. M. 1966. Advances and challenges in the control of plant diseases through breeding. pp. 117-126. In: Pest control by chemical, biological, genetic, and physical means. (Proc., AAAS Symposium). U.S. Dept. Agr., Agr. Res. Serv., Misc. Publ. 33-110.
5. _____, J. F. Schafer, L. E. Compton, and F. L. Patterson. 1957. A mature-plant type of wheat leaf rust resistance of composite origin. *Phytopathology* 47:690-692.
6. Hagan, W. L., and A. L. Hooker. 1965. Genetics of reaction to *Puccinia sorghi* in eleven corn inbred lines from Central and South America. *Phytopathology* 55:193-197.
7. Hilu, H. M. 1965. Host-pathogen relationships of *Puccinia sorghi* in nearly isogenic resistant and susceptible seedling corn. *Phytopathology* 55:563-569.
8. Hooker, A. L. 1955. Corn diseases in Iowa nurseries in 1953 and 1954. *Plant Dis. Rptr.* 39:381-383.
9. _____. 1962. Additional sources of resistance to *Puccinia sorghi* in the United States. *Plant Dis. Rptr.* 46:14-16.
10. _____. 1962. Corn leaf disease. Proc., 17th Ann. Hybrid Corn Ind. Res. Conf. 17:24-36.
11. _____. 1963. A second major gene locus in corn conditioning resistance to *Puccinia sorghi*. *Phytopathology* 53:221-223.
12. _____. 1967. The genetics and expression of resistance in plants to rusts of the genus *Puccinia*. *Ann. Rev. Phytopath.* 5:163-182.
13. _____. 1967. Inheritance of mature plant resistance to rust in corn (abstract). *Phytopathology* 57:815.
14. _____, and P. M. LeRoux. 1957. Sources of protoplasmic resistance to *Puccinia sorghi* in corn. *Phytopathology* 47:187-191.
15. _____, and W. A. Russell. 1962. Development of nearly isogenic rust-resistant lines of corn (abstract). *Phytopathology* 52:14.
16. _____, and _____. 1962. Inheritance of resistance to *Puccinia sorghi* in six corn inbred lines. *Phytopathology* 52:122-128.
17. _____, and K. M. S. Saxena. 1967. Apparent reversal of dominance of a gene in corn for resistance to *Puccinia sorghi*. *Phytopathology* 57:1372-1374.
18. _____, G. F. Sprague, and W. A. Russell. 1955. Resistance to rust (*Puccinia sorghi*) in corn. *Agron. J.* 47:388.
19. Jensen, N. F. 1952. Intra-varietal diversification in oat breeding. *Agron. J.* 44:30-34.
20. Lee, B. H., A. L. Hooker, W. A. Russell, J. G. Dickson, and A. L. Flangas. 1963. Genetic relationships of alleles on chromosome 10 for resistance to *Puccinia sorghi* in 11 corn lines. *Crop Sci.* 3:24-26.
21. LeRoux, P. M., and J. G. Dickson. 1957. Physiology, specialization, and genetics of *Puccinia sorghi* on corn and of *Puccinia purpurea* on sorghum. *Phytopathology* 47:101-107.
22. Mains, E. B. 1962. Studies in rust resistance. *J. Hered.* 17:313-325.
23. _____. 1931. Inheritance of resistance to rust, *Puccinia sorghi*, in maize. *J. Agr. Res.* 43:419-430.
24. _____, F. J. Trost, and G. M. Smith. 1924. Corn resistance to rust, *Puccinia sorghi* (abstract). *Phytopathology* 14:47-48.
25. Malm, N. R., and J. B. Beckett. 1962. Reactions of plants in the tribe Maydeae to *Puccinia sorghi* Schw. *Crop Sci.* 2:360-361.
26. _____, and A. L. Hooker. 1962. Resistance to rust, *Puccinia sorghi* Schw., conditioned by recessive genes in two corn inbred lines. *Crop Sci.* 2:145-147.
27. Person, C. 1966. Genetic polymorphism in parasitic systems. *Nature* 212:266-267.
28. Peterson, R. F., A. B. Campbell, and A. E. Hannah. 1948. A diagrammatic scale for estimating rust intensity on leaves and stems of cereals. *Can. J. Res. (Sect. C.)* 26:496-500.

29. Rhoades, M. M., and Virginia H. Rhoades. 1939. Genetic studies with factors in the tenth chromosome of maize. *Genetics* 24:302-314.
30. Rhoades, Virginia H. 1935. The location of a gene for disease resistance in maize. *Proc. Nat. Acad. Sci.* 21:243-246.
31. Russell, W. A. 1965. Effect of corn leaf rust on grain yield and moisture in corn. *Crop Sci.* 5:95-96.
32. _____, and A. L. Hooker. 1959. Inheritance of resistance in corn to rust, *Puccinia sorghi* Schw., and genetic relationships among different sources of resistance. *Agron. J.* 51:21-24.
33. _____, and _____. 1962. Location of genes determining resistance to *Puccinia sorghi* Schw. in corn inbred lines. *Crop Sci.* 2:477-480.
34. Saxena, K. M. S., and A. L. Hooker. 1964. The nature of locus Rp_1 conditioning resistance to rust in corn (abstract). *Phytopathology* 54:905.
35. _____, and _____. 1968. On the structure of a gene for disease resistance in maize. *Proc. Nat. Acad. Sci. USA* 61:1300-1305.
36. Simmonds, N. W. 1962. Variability in crop plants, its use and conservation. *Biol. Rev. Cambridge Phil. Soc.* 37:422-465.
37. Stakman, E. C., and J. J. Christensen, and H. E. Brewbaker. 1928. Physiologic specialization in *Puccinia sorghi*. *Phytopathology* 18:345-354.
38. Suneson, C. A. 1960. Genetic diversity—a protection against plant diseases and insects. *Agron. J.* 52:319-321.
39. Ullstrup, A. J. 1965. Inheritance and linkage of a gene determining resistance in maize to an American race of *Puccinia polysora*. *Phytopathology* 55:425-428.
40. Van Dyke, C. G., and A. L. Hooker. 1969. The Z reaction in corn to *Puccinia sorghi*. *Phytopathology* 59:33-36.
41. Wallin, J. R. 1951. An epiphytotic of corn rust in the North Central Region of the United States. *Plant Dis. Rptr.* 35:207-211.
42. Wilkinson, D. R., and A. L. Hooker. 1968. Genetics of reaction to *Puccinia sorghi* in ten corn inbred lines from Africa and Europe. *Phytopathology* 58:605-608.

Consequences of Intensive Cultural Practices on Soybean Diseases in the Corn Belt¹

by John Dunleavy²

ABSTRACT

Concomitant with increased soybean production in the Corn Belt, the incidence of stem canker increased, downy mildew became widespread, brown stem rot and *Phytophthora* rot were found, and there was a lowering of seed quality throughout USA soybean-growing regions. The prevalence of stem canker was due mainly to popularity of the susceptible variety, Hawkeye, which largely has been replaced by other varieties. Downy mildew can increase dramatically in areas of intensive soybean production, but is highly dependent upon environmental conditions. Consequently, it is difficult to detect a high correlation between increased soybean acreage and the incidence of downy mildew. Brown stem rot is not as environment sensitive as is downy mildew. In Iowa, there was a high correlation between incidence of known *Cephalosporium*-infested fields and acreage devoted to soybean production. Yield losses from brown stem rot show the consequences of intensified soybean production.

The primary soybean diseases that affect seed quality are pod and stem blight, purple seed stain, soybean wilt, bud blight, and soybean mosaic. Another cause of poor seed quality is related to root deterioration initiated by high bacterial populations in Corn Belt soils. Through intensive selection of soybean varieties for high yield, we may have tended to select varieties that support higher bacterial populations on roots. Such plants are less likely to produce seed of good quality under conditions of moisture stress and infection by other microorganisms.

INTRODUCTION

Soybean acreage in Iowa has increased from less than 1 million acres in 1940 to 5.72 million acres in 1968. Restricted production of other crops and good markets for soybeans and soybean products were primarily responsible for this increase. Concomitant with this increase, several significant soybean disease problems were noted: a) The incidence of stem canker increased, b) downy mildew became widespread, c) brown stem rot and *Phytophthora* rot were found in the Corn Belt, and d) there was a lowering of the quality of seed produced throughout the soybean-growing regions of the country. I will discuss these disease problems and relate them to the intensification of soybean culture in the Corn Belt.

¹Joint contribution from the Crops Research Division, Agricultural Research Service, U.S. Department of Agriculture and the Iowa Agriculture and Home Economics Experiment Station, Ames, as Journal Paper No. J-5822, Project 1179. Publication No. 506 of the U.S. Regional Soybean Laboratory, Urbana, Illinois.

²Plant Pathologist, Crops Research Division, Agricultural Research Service, U.S. Department of Agriculture, and Professor of Plant Pathology, Iowa State University.

STEM CANKER

The prevalence of stem canker, caused by *Diaporthe phaseolorum* (Cke. & Ell.) Sacc. var. *caulivora*, Athow & Caldwell, was due in large measure to popularity of the variety Hawkeye, which is more susceptible than other varieties to this disease. Hawkeye is now being replaced rapidly by other less-susceptible varieties, and stem canker should decrease but remain a serious threat.

DOWNY MILDEW

Downy mildew, caused by the fungus *Peronospora manshurica* (Naum.) Syd. ex Gaum., is one of the most common soybean diseases in the USA. Infected soybean plants have reduced photosynthetic activity because of development of many chlorotic spots on the leaves. The fungus also invades pods and produces many oospores on the surface of developing seed. Oospore-encrusted seeds usually are smaller than seeds from uninfected pods. The fungus increases rapidly on susceptible varieties. Only 8-10 days are required from inoculation to spore production. The disease can increase dramatically in areas of intensive soybean production but is highly dependent upon environmental conditions.

Consequently, it is difficult to detect a high correlation between increased soybean acreage and the incidence of downy mildew.

BROWN STEM ROT

Brown stem rot of soybeans, caused by *Cephalosporium gregatum* Allington & Chamberlain, is primarily a disease of vascular tissues that eventually spreads to the stem pith, causing a brown discoloration (fig. 1). The development of brown stem rot is not as environment sensitive as downy mildew. We have records of brown stem rot prevalence in Iowa since 1956. Soybean acreage in Iowa increased from 2.5 million acres in 1956 to 4.1 million acres in 1964. When the yearly incidence of brown stem rot in Iowa from 1956 to 1964 was compared with soybean acreage (fig. 2), there was a high correlation (0.979) between incidence of known *C. gregatum*-infested fields and acreage devoted to soybean production (8).

A detailed survey of Iowa for brown stem rot was made in 1966 (13). The disease was found in 55% of 487 soybean fields examined and in 91% of the counties sampled. The mean height of browning in stems was 8 inches (18% of the total height of infected stems). Greatest incidence of brown stem rot occurred in an 11-county area in the south-central section of the state, in which 79% of the fields were affected by the disease.

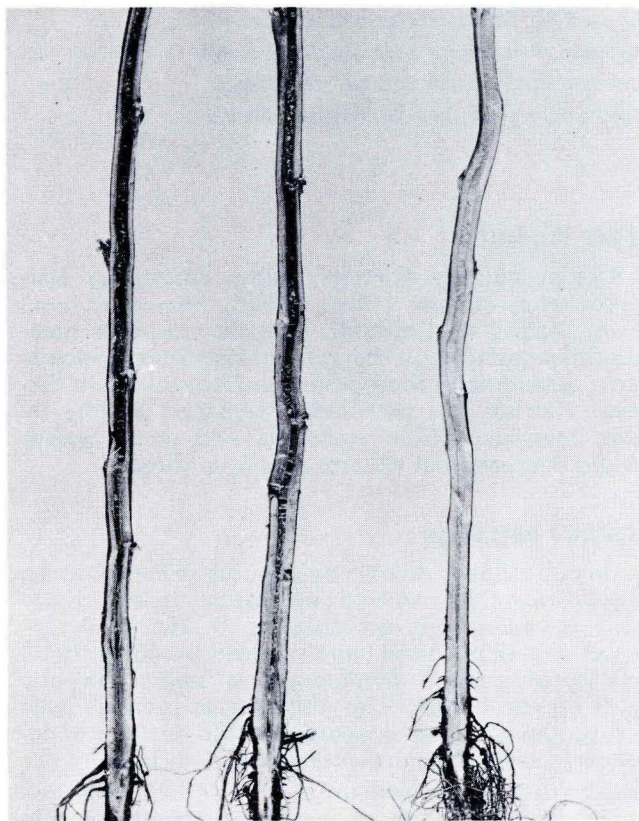

Fig. 1. Soybean stems with pith rotted by *Cephalosporium gregatum* (left and center); healthy soybean stem (right).

Until recently, mung bean (*Phaseolus aureus* Roxb.) was the only species, besides soybeans, known to be susceptible to *C. gregatum*. In the fall of 1966, I observed a red clover field with 97% of the plants infected by *C. gregatum* (9) (fig. 3). Symptoms of *C. gregatum* infection were observed in 90-100% of the soybeans grown in another part of the same field. The previous crop sequence in this field was soybeans, corn, red clover, red clover. Thus, there was a high incidence of infection in soybean plants in a field not planted to soybeans for the 3 previous years. Before this time, we had thought that keeping a field free of soybeans for 3 years would provide adequate brown-stem-rot control. Because of these findings, however, red clover also should be eliminated from the rotation for adequate brown-stem-rot control.

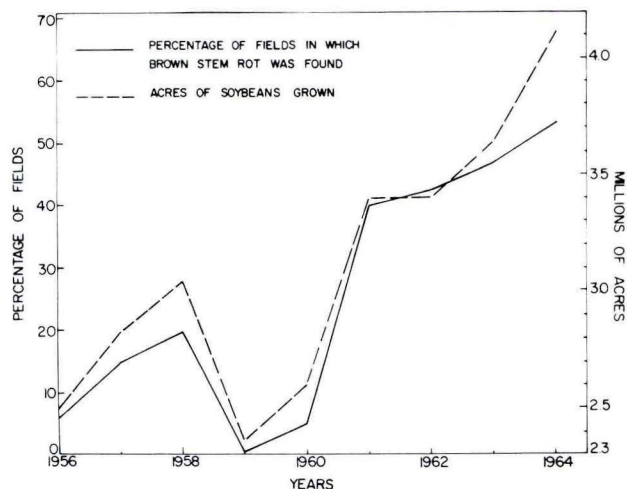

Fig. 2. Percentage of Iowa soybean fields in which brown stem rot was found from 1956 through 1964 and the number of acres devoted to soybean production in Iowa in the same period.



Fig. 3. Progressive stages (left to right) of a crown and root rot of red clover caused by *Cephalosporium gregatum*.

In a series of replicated tests from 1959 through 1964, satisfactory control of brown stem rot was achieved with a 5-year corn and 1-year soybean crop rotation (14). The percentage of soybean plants infected with *C. gregatum* decreased from 100% at the beginning of the test, to 6% after growth of corn for 5 years (table 1). Seed yield from infested plots, planted continuously to soybeans for 10 years, was about 44% of the yield obtained following 5 years of continuous corn. When soybeans were grown on infested fields after two or three successive corn crops, the highest seed yields were obtained from soil planted to corn for 3 years. Soybean plants grown continuously in infested soil were 18 cm shorter, produced seed lighter by 2 g/100 seed, and produced 28% fewer seeds than soybean plants grown after 5 years of corn. In 13 corn-soybean rotations studied, soybean yield loss was due to a 64% reduction in seed number and a 36% reduction in seed size.

This shows the consequences of intensified soybean production. Iowa's soybean acreage increased 10% from 1966 to 1967. This means that soybean fields are closer together, that soybeans are following soybeans in rotations more often, and that the incidence and severity of brown stem rot will continue to increase.

POOR-QUALITY SEED

The fourth disease problem was the increased occurrence of poor-quality seed. There are numerous causes of poor seed: Insufficient light, nutrients, and water for proper plant development are only a few of the most obvious causes. Disease, improper use of herbicides, and poor cultural practices also may result in inferior seed. The primary soybean diseases that affect seed quality are pod and stem blight, caused by *Diaporthe phaseolorum* (Cke. & Ell.) Sacc. var. *sojae* (Lehman) Wehm. (5); purple seed stain, caused by *Cercospora kikuchii* (T. Matsu. & Tomoyasu) Gard. (16); soybean wilt, caused by *Corynebacterium flaccumfaciens* (Hedges) Dow (7, 10); bud blight, caused

by the tobacco ring spot virus (1); and soybean mosaic (19).

Another of the important causes of poor seed quality in soybeans is related to root deterioration initiated by high bacterial populations in Corn Belt soils. Any approach to soil microbiology involving soil microflora-root interactions would probably be very complex. But recent research dealing with the interaction of a spore-forming bacterium (*Bacillus subtilis* (Cohn) Prazmowski) and the soybean plant has given a partial insight into this soil "complex" and associated root problems resulting in inferior seed.

I first became aware of the close association of *B. subtilis* with the soybean plant while working with soybean wilt caused by *Corynebacterium flaccumfaciens*. *B. subtilis* was frequently isolated from plants in association with *C. flaccumfaciens*. Later investigations revealed that *B. subtilis* was nearly always associated with soybean plants. This organism was isolated from field-grown Ford soybeans (roots, stem vascular system, and leaves) at weekly intervals from the seedling stage to plant maturity.

There have been numerous reports of isolation of bacteria from healthy plant tissues (3, 4, 6, 12, 15, 17, 21 through 31, 33 through 35). Unfortunately, some workers took insufficient precautions to prevent sampling ordinary contaminants. Others (4, 17, 22, 27, 29, 31), however, have taken elaborate precautions to eliminate contaminants. Using control manipulations, Burcik (4) demonstrated that the probability of contamination in his experiments was less than 1%. Of 200 stored potatoes sampled by Burcik, only 30 had internal tissues free of bacteria. Sanford (29), Tervet and Hollis (31), and Hollis (17) also have reported bacteria in stems, stolons, and tubers of potato plants. Philipson and Blair (23) reported species of *Aerobacter*, *Bacillus*, and *Flavobacterium* isolated from the interior of clover roots. Samish and associates (27, 28) isolated various bacteria from internal tissues of green tomato fruit. By inoculating sepals of tomato fruit with *Serratia* before harvest, they proved that the bacterium moved into the pulp of tomato fruit within 1-5 weeks (28). Such instances illustrate the occurrence of bacteria in normal plant tissues. Very little is known of the role of these bacteria within plants.

Certain soybean varieties (Ford and Lincoln) harbor high populations of *B. subtilis*, whereas others (Blackhawk and Chief) harbor low populations (12) (fig. 4). *B. subtilis* is very sensitive to changes in certain plant nutrients and is particularly sensitive to changes in P (phosphorus) and N (nitrogen). This bacterium is associated with P toxicity symptoms in soybeans (fig. 5) and with soybean root deterioration. The organism is a halophyte and can grow in media containing 7% sodium chloride. Howell (18) described the first two varieties as very sensitive (VS) to P and the last two as tolerant (T). Later, Bernard and Howell (2) reported that response of soybeans to high concentrations of P in the nutrient solution was controlled by a single gene pair.

Table 1. Mean percentage infection with *Cephalosporium gregatum*, seed yield and percentage seed yield reduction of Chippewa soybeans in five corn-soybean rotations combined for 1963-64.

Rotation		Plants infected	Seed yield	Seed yield reduction
Corn	Soybeans			
years	years	%	bu/acre	%
5	1.....		33.2 ^a	
4	1.....	16	30.8**	7.2
3	1.....	48	30.1**	9.3
2	1.....	90	24.9	25.0
1	1.....	98	22.4	32.5
0	6.....	100	18.7**	43.7

^a This value only was estimated from other yield data in 1963-64 rotations.

** Different from the mean at 1% level of probability.

In more recent work in my laboratory, we successfully controlled P toxicity symptoms in VS soybeans by using a quaternary-ammonium compound (Amo-1618) that inhibits growth of *B. subtilis* in culture (11). Thus, it seems that the gene pair studied by Bernard and Howell (2) directly controls bacterial populations associated with the plant and only indirectly controls sensitivity of soybean plants to P through bacterial growth. Admittedly, present evidence for such a relationship is sketchy, but the importance of establishing a role for bacteria in plants that appear healthy is quite obvious. If these bacteria cause extensive plant damage

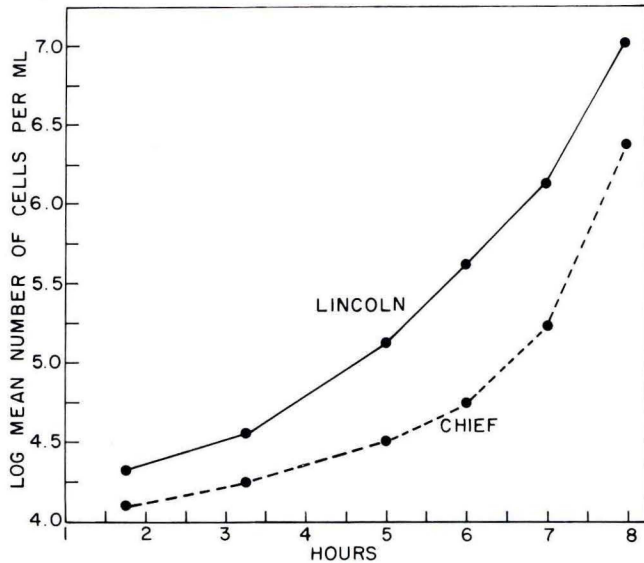

Fig. 4. Growth of *Bacillus subtilis* in root-extract broth prepared from Lincoln (very sensitive) and Chief (tolerant) soybeans.

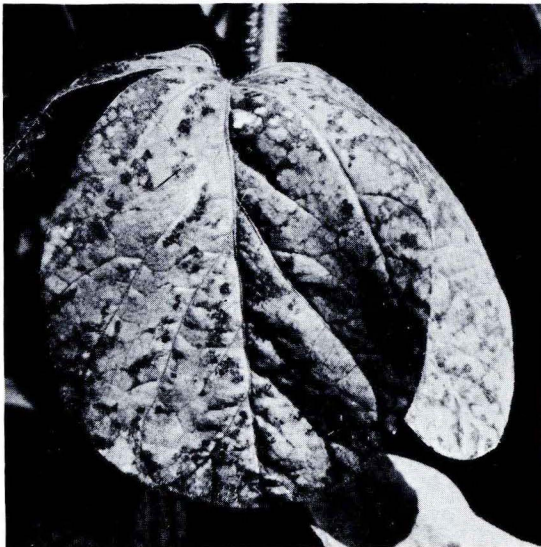

Fig. 5. Symptoms on a leaflet from a Lincoln (very sensitive) soybean plant grown in a high phosphorus nutrient solution.

when high concentrations of nutrients are used, might they also cause some damage to roots of plants of VS varieties when normal concentrations of nutrients are used?

There has been a decided tendency among soybean breeders in the Corn Belt to select varieties for release that are either sensitive (S) or VS to P. In this group are Ford, Lincoln, Shelby, Kent, Chippewa, Grant, Clark, Ross, and Amsoy. In every instance involving the selection of these varieties, the breeder was selecting for agronomic excellence and unaware of the response of the variety to either P or *B. subtilis*. This suggests that there may be a relation between bacteria associated with soybean plants and plant yield. There is considerable literature to support such a position. Waksman (36) pointed out that bacteria favor the growth of higher plants by affecting the availability of various nutrient elements essential for plant growth, particularly carbon (as carbon dioxide), nitrogen, and P. Nucleic acids are a common source of organic P in the soil and are abundant in bacterial cells (36). Various bacteria are capable of breaking down free nucleic acids and liberating P as phosphate. This is especially important because of Linford's observations of massive bacterial colonies on various crop plants (20). Such colonies would offer a ready source of nucleic acids for later degradation.

Bacteria contribute to P availability by producing various acids that increase the solubility of otherwise insoluble phosphate compounds. It has been estimated that about 35% of all soil bacteria can dissolve tricalcium phosphate (32). Because this conversion takes place most actively near the root tips, it is by no means negligible (32).

It is generally recognized by soybean pathologists in the Corn Belt that root rot is a major problem. I am not suggesting that *B. subtilis* or related soil bacteria are primary pathogens and that they cause this root rot. But I am suggesting that, through intensive selection of soybean varieties for high yield, we may have tended to select varieties that support higher bacterial populations on roots. I think that, under optimum (or even average) conditions, there is little question of the superiority of such varieties. The question is: How do such varieties perform under adverse conditions; e.g., limitation of moisture? I believe that bacteria (e.g., *B. subtilis*) are involved in root damage and that plants so affected are less able to withstand moisture stress and possible infection by other microorganisms. Such plants are less likely to produce seed of good quality.

DISCUSSION

For this discussion, there are two general categories of soybean diseases, a) those highly dependent upon environmental factors for spread and development and b) those dependent on heavy inoculum production for spread and development. Intensive cultural practices have relatively little effect

on diseases in the first category because environmental factors, such as the weather, ultimately determine infection. Downy mildew is a good example of a disease in this category.

Intensive cultural practices do play an important role in the development of diseases in the second category. Brown stem rot is a good illustration. Indications are that agriculture in the Corn Belt will be progressively intensified. At present, this means more corn and more soybeans. As soybean production continues to increase, we should be alert to the buildup of diseases in the second category.

In conclusion, we must not forget that, in the Corn Belt, we are primarily interested in growing maximum yields of corn on a minimum acreage, which requires relatively heavy application of fertilizers. We must also remember that some soil microorganisms (e.g., *B. subtilis*) respond in a way similar to higher plants to the addition of fertilizers to the soil. Thus, as corn is cultivated more intensively, the soil environment is being altered for soybeans and other crops. This change in soil environment could, in large measure, affect trends in soybean disease development over an extended period.

LITERATURE CITED

1. Athow, Kirk L., and J. B. Bancroft. 1959. Development and transmission of tobacco ring-spot virus in soybean. *Phytopathology* 49:697-701.
2. Bernard, R. L., and R. W. Howell. 1964. Inheritance of phosphorus sensitivity in soybeans. *Crop Sci.* 4:298-299.
3. Burcik, E. 1940. Experimente und Bemerkungen zur Arbeit von H. Schanderl: Über die Bacteriensymbiose bei Leguminosen und Nichtleguminosen. *Planta* 30:683-688.
4. _____. 1948. Eine Kritik der Symbiosetheorie von H. Schanderl auf Grund neuerer eigener Untersuchungen. *Arch. Mikrobiol.* 14:309-333.
5. Crittenden, H. W., H. E. Bloss, and F. Y. Yelen. 1967. Pod and stem blight of the soybean in Delaware. *Del. Agr. Exp. Sta. Circ.* 4. 5pp.
6. Dawid, W. 1957. Untersuchungen über die Entwicklungsmöglichkeit von Bakterien aus normalen Tomatengewebe. *Z. Pflanzenkrankh. Pflanzenschutz* 64:205-214.
7. Dunleavy, John. 1963. A vascular disease of soybeans caused by *Corynebacterium* sp. *Plant Dis. Rptr.* 47:612-613.
8. _____. 1966. Factors influencing spread of brown stem rot of soybeans. *Phytopathology* 56:298-300.
9. _____. 1967. Red clover infected by *Cephalosporium gregatum* (abstract). *Phytopathology* 57:810.
10. _____, D. W. Chamberlain, and J. P. Ross. 1966. Soybean diseases. *U. S. Dept. Agr. Handbook* 302. 38 pp.
11. _____, and J. F. Kunkel. 1968. Inhibition of *Bacillus subtilis* by Amo-1618. *Phytopathology* 58:456-459.
12. _____, _____, and J. J. Hanway. 1966. High populations of *Bacillus subtilis* associated with phosphorus toxicity in soybeans. *Phytopathology* 56:83-87.
13. _____, and R. C. Lambe. 1967. Incidence of brown stem rot of soybeans in Iowa. *Plant Dis. Rptr.* 51:438-441.
14. _____, and C. R. Weber. 1967. Control of brown stem rot of soybeans with corn-soybean rotations. *Phytopathology* 57:114-117.
15. Fischer, W. 1948. Über einige Fehlerquellen bei der Prüfung von Pflanzenteilen auf das Vorkommen von Bakterien. *Arch. Mikrobiol.* 14:343-351.
16. Gardner, M. W. 1927. Indiana plant diseases. *Ind. Acad. Sci. Proc.* 36:231-247.
17. Hollis, J. P. 1951. Bacteria in healthy potato tissue. *Phytopathology* 41:350-366.
18. Howell, R. W. 1954. Phosphorus nutrition of soybeans. *Plant Physiol.* 29:477-483.
19. Kennedy, B. W., and R. L. Cooper. 1967. Association of virus infection with mottling of soybean seed coats. *Phytopathology* 57:35-37.
20. Linford, M. B. 1942. Methods of observing soil flora and fauna associated with roots. *Soil Sci.* 53:93-103.
21. Lutman, B. F., and H. E. Wheeler. 1948. *Bacillus megatherium* DeBary from the interior of healthy potato tubers. *J. Wash. Acad. Sci.* 38:336-340.
22. Marcus, O. 1942. Über das Vorkommen von Mikroorganismen in pflanzlichen Geweben. *Arch. Mikrobiol.* 13:1-44.
23. Philipson, M. N., and I. D. Blair. 1957. Bacteria in clover root tissue. *Can. J. Microbiol.* 3:125-129.
24. Rippel, A. 1941. Nochmals zur Frage des Vorkommens von Mikroorganismen in gesunden pflanzlichen Geweben. *Planta* 32:391-394.
25. Rippel-Baldes, A. 1948. Über die angebliche Stickstoffbindung durch Nichtleguminosen. *Arch. Mikrobiol.* 14:334-342.
26. Romwalter, A., and A. Kiraly. 1939. Hefearten und Bakterien im Fichten. *Arch. Mikrobiol.* 10:87-91.
27. Samish, Z., R. Etinger-Tulczynska, and M. Bick. 1961. Microflora within healthy tissues. *J. Appl. Microbiol.* 9:20-25.
28. _____, and _____. 1963. Distribution of bacteria within the tissue of healthy tomatoes. *J. Appl. Microbiol.* 11:7-10.
29. Sanford, G. B. 1948. The occurrence of bacteria in normal plants and legumes. *Sci. Agr.* 28: 21-25.
30. Stührk, A. 1941. Die Obst- und Gemuseverwertungindustrie Augs. A. No. 42 (Germany).
31. Tervet, I. W., and J. P. Hollis. 1948. Bacteria in the storage organs of healthy plants. *Phytopathology* 38:960-967.
32. Teuscher, H., and R. Adler. 1960. The soil and its fertility. Reinhold Publishing Corp. New York. 446 pp.
33. Thomas, S. B., and P. M. Hobson. 1955. Coli-aerogenes bacteria isolated from ears and panicles of cereal crops. *J. Appl. Microbiol.* 18:1-8.
34. Thomas, W. D., and R. W. Graham. 1952. Bacteria in apparently healthy pinto beans. *Phytopathology* 42:214.
35. Tonzig, S., and L. Bracci-Orsenigo. 1955. Sulla presenza di batteri nei vari organi della piante superiori. *Nuova Giorn. Botan. Ital. (NS)* 62: 1-8.
36. Waksman, S. A. 1952. *Soil Microbiology*. John Wiley and Sons, Inc. New York. 356 pp.

Soybean-Cyst-Nematode Damage as Associated with the Intensive Culture of Soybeans in Southeastern Missouri

by A. H. Hagge¹

ABSTRACT

The soybean cyst nematode (*Heterodera glycines* Ichinohe), first found in North Carolina in 1954, now infests an estimated 2 million acres in 9 states. Most of the known infested acres are in a large commercial soybean-growing area in Arkansas, Illinois, Indiana, Kentucky, Mississippi, Missouri, and Tennessee in the Ohio and Mississippi river valleys. Damage in this 8-state area increased spectacularly from a minor loss in 1958 to an estimated monetary loss of more than \$9 million in 1965 and \$8 million in 1966. Loss in Missouri, which increased from an estimated 23,900 bu in 1959 to 1,160,000 bu in 1966, appears associated with the successive planting and limited rotation of soybeans. New improved varieties of soybeans—Pickett, Custer, and Dyer—have been developed for resistance to the nematode. Areas infested are under state-federal quarantine.

INTRODUCTION

The soybean cyst nematode (*Heterodera glycines* Ichinohe), which may destroy a crop of soybeans in a heavily infested field, was first found in the USA in North Carolina in 1954. Since then infestation has been recorded in Virginia and in an extensive area in the Mississippi and Ohio river valleys, including parts of Arkansas, Illinois, Indiana, Kentucky, Mississippi, Missouri, and Tennessee.

First symptoms of cyst-nematode damage in soybeans are the appearance in fields of more or less circular spots, up to an acre or more in size (fig. 1), of stunted (fig. 2) and off-color plants. Symptoms appear only if large numbers of nematodes attack plant roots (fig. 3). Conversely, the pest may be present in low populations on roots without visible evidence on soybean plants. Roots of what appear as normal, healthy plants may support a nematode population that will attack the following crop in damaging proportions if soybeans are planted again. On the other hand, damaged and dwarfed roots of stunted plants in heavily infested parts of a field support a limited number of nematodes, which may result in a reduced number of cysts in the soil. Heavy attack by the pest stunts the root system; thus, the nematode population build-up is limited by the available root tissue.

Invasion by the pest is through young, hair-like roots (fig. 3). The degree of damage depends

on many factors, including size of plants when attacked, temperature, soil moisture, and soil fertility. The soybean cyst nematode reproduces effectively only on suitable host crops, such as soybeans, snap beans, lespedeza, white lupine, and several susceptible weeds. Larvae eventually die in the absence of host plants.

INFESTATION IN ASIA

The soybean cyst nematode was present in Japan, Korea, and Manchuria for 40 or more years before it was found in the USA. Occurrence in Japan was first recorded in 1915. Damage may have occurred there some years previously. The Japanese refer to the disease as "yellow dwarf" because of a characteristic yellowing and stunting of infested plants. Losses of up to 70% have occurred in fields with spot infestations in Japan. Complete loss has been noted where plants in an entire field were attacked. Ichinohe (1) reported that a 5- or 6-year rotation was excellent for starving the nematode and for obtaining high yields of soybeans. He further indicated that good yields were obtained when soybeans were planted every third or fourth year in comparison with successive cropping, but such rotations did not effectively control the nematode. Ichinohe suggested that trap crops, such as alfalfa and red clover, were helpful in retarding the pest. He indicated that control of the nematode has been unknowingly carried on by Japanese farmers who commonly grow legume crops in some of the soybean-cyst-nematode-infested areas.

¹Former Supervisor-in-Charge (now retired), Iowa and Missouri, Plant Pest Control Division, ARS, USDA, Ames, Iowa.

INFESTATION IN THE UNITED STATES

Approximately 2 million acres are known to be infested in the USA (fig. 4). This is a tremendous acreage, considering that the pest was not discovered in this country until 1954. About 99%, or approximately 1.9 million, of the known infested acres are in the Mississippi River Valley. Ninety percent of the acreage is in three states, with 645,000 acres in Arkansas, 500,000 in Missouri, and 638,000 in Tennessee.

Losses in Mississippi River Valley States

Nematode damage was first noted in the Mississippi River Valley in a few soybean fields in Tennessee in 1956. Pronounced crop damage was not observed in 1957. Patches of stunted, yellowing plants were observed in approximately 30 fields in Tennessee in 1958. Loss in other Mississippi river valley states was very minor during that year. Damage increased considerable in 1959 and from 1960 to 1966. Monetary loss in the USA was estimated in excess of \$9 million in 1965 and at \$8 million during 1966. The major portion of these losses occurred in Arkansas, Kentucky, Missouri, and Tennessee.

Losses and Cropping Practices in Missouri

Soybean-cyst-nematode damage has been very severe in southeastern Missouri, and this appears directly related to cropping practices in that area. Soybeans in one 80-acre Missouri field (fig. 5) yielded only an estimated 4.5 bu/acre. This represented a reduction in yield of around 25 bu/acre, or 2,000 bu, with a monetary loss of over \$4,500. Abundant female nematodes attacked the roots of soybean plants throughout the field (fig. 3). The number of pods produced on stunted plants was very limited as compared with those on healthy soybeans (fig. 2).

Principal crops produced in southeastern Missouri are soybeans, cotton, corn, wheat, sorghum, oats, and truck crops. A study of acreage figures for seven infested counties for 1964 showed that 1,704,000 acres were planted to cultivated crops. A total of 861,000 acres (about 50% of the total) was planted to soybeans, 351,000 to cotton, 254,000 to wheat, 233,000 to corn, and 15,000 to other crops, including oats, sorghum, and truck crops.

A high percentage of the cultivated cropland in the seven Missouri counties infested with the nematode has been planted to soybeans for the past 20 years. Acres planted to soybeans annually were compared with the total cultivated crop acreage from 1947 to 1966 (fig. 6). Cultivated land planted annually to soybeans increased over the 20-year period from 29.7% in 1947 to 65.5% in 1966. Over 50% of the cultivated acres were planted to soybeans from 1958 through 1966.

First appreciable damage, with a reduction in yield estimated at 24,000 bu, was observed in a limited number of fields in Missouri in 1959 (fig. 6). Numerous additional fields with minor damage were noted in 1960 and 1961; however, over-all estimated loss was below that of 1959. Damage

in the infested Missouri counties increased spectacularly from 1962 to 1966, with an estimated loss of 34,600 bu (valued at \$75,000) in 1962, 117,000 bu (\$300,000) in 1963, 378,000 bu (\$980,000) in 1964, 881,000 bu (\$2,200,000) in 1965, and 1,160,000 bu (valued at \$3,000,000) in 1966. This spectacular increase in nematode damage came after soybeans were planted on the majority of the cultivated area of the seven counties, suggesting that monoculture was a contributing factor.

What are the reasons for the intensive culture of soybeans in this area of Missouri? Probably the greatest factor is the presence of considerable sandy land more suitable for soybeans than for other crops with a higher water requirement. Planting conditions often are more favorable for soybeans than for cotton. The soybean acreage has not been restricted by government controls as have acreages of some other crops. Production of corn often is quite marginal because of the droughty soil types in the area. Winter wheat has done well, but farmers often double-crop wheat with soybeans in the same year, which does not solve the cyst-nematode problem.

CONTROL

State-Federal Quarantine

Infested acres (fig. 4) are under state-federal quarantine to retard spread of the pest through movement of contaminated soil on farm machinery, construction equipment, plants, seed, and other agricultural products. Infested soil adhering to farm equipment (fig. 7) may spread the pest to other fields and to other states. Soil peds (small lumps of soil) (fig. 8) containing viable larvae in soybean seed also are a means of spread. The quarantine prohibits movement of equipment or products unless they are first washed, treated, or processed to eliminate contaminating nematodes. Equipment and seed then may be moved considerable distances, as was indicated in a study of properly treated farm equipment that was moved from the infested area in southeastern Missouri to other states and to Mexico and Canada during the 1966 fiscal year (fig. 9). For instance, 805 pieces of equipment were approved for movement to Iowa, 166 to Minnesota, and 1,302 to Illinois, after they met quarantine requirements. Regulatory action probably has prevented long-distance spread of the pest in numerous instances.

Crop Rotations

Crop rotations, although not always satisfactory to the farmer, are helpful in curbing nematode damage. Soybeans planted following cotton in a portion of a Missouri field yielded about 5 bu/acre more than soybeans following soybeans in the remainder of the field. Soybeans following soybeans were severely attacked by the nematode, while those following cotton were attacked lightly. Soybeans and other host crops should be kept off infested fields for at least 3 years to reduce the nematode population.

Resistant Varieties

Resistance to the nematode has been found by workers in the state-federal cooperative soybean-breeding program. Resistance was not present in any yellow-seeded variety among the more than 3,000 soybean strains tested. Resistance, however, was obtained from 'Peking,' a black-seeded variety

not desirable for commercial production. Peking was used as a donor parent to transfer resistance to yellow-seeded varieties. Three resistant varieties, 'Pickett,' 'Custer,' and 'Dyer' have been developed for planting in infested areas. Seed sufficient to plant much of the heavily infested acreage should be available in 1968.

BIBLIOGRAPHY

1. Ichinohe, Minoru. 1959. Studies on the soybean cyst nematode, *Heterodera glycines* and its injury to soybean plants in Japan. Plant Dis. Rptr. (Suppl.) 260:237-248.
2. Kyd, Stirling, and J. Fleetwood. 1959. The soybean cyst nematode. Mo. Agr. Ext. Serv. Circ. 725.
3. Missouri Crop and Livestock Reporting Service. 1947-1966. Missouri farm census by counties.
4. Skotland, C. B. 1956. Life history and host range of the soybean cyst nematode (abstract). Phytopathology 46:27.
5. Spears, Joseph F. 1959. The nematode problem. Agr. Chem. 14 (1):39-41.
6. _____. 1959. Current status of the soybean cyst nematode. Soybean Digest 19 (11):58-61.
7. _____. 1962. Can the soybean cyst nematode be controlled? Soybean Digest 22 (11):30-32.
8. U. S. Department of Agriculture. 1956. Soybean cyst nematode. U. S. Dept. Agr., Agr. Res. Serv., Spl. Rpt. 22-29. 10 pp.
9. _____. 1961. Soybean cyst nematode: progress in research and control. U. S. Dept. Agr., Agr. Res. Serv., Spl. Rpt. 22-72. 20 pp.
10. _____. 1966. The soybean cyst nematode: a new pest. U. S. Dept. Agr., Agr. Res. Serv., Plant Pest Control Div., Misc. Publ. PA-333. 4 pp.

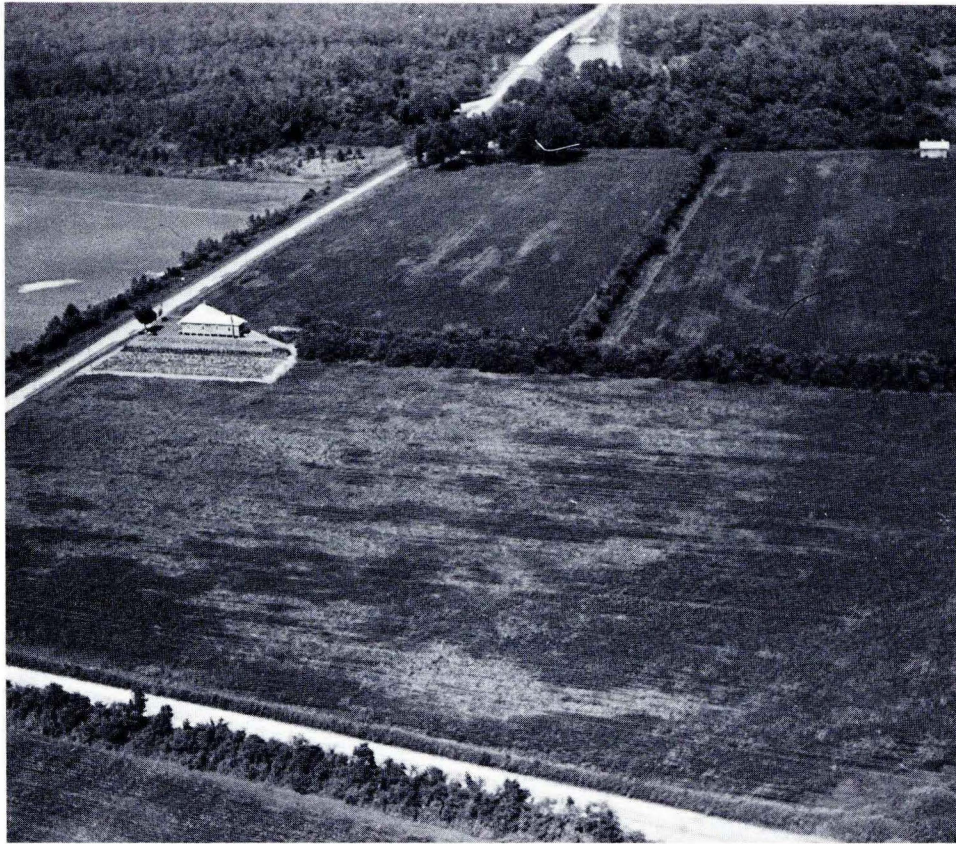

Fig. 1. Soybean-cyst-nematode damage in severely infested soybean fields.

Fig. 2. Left - a soybean plant from a field (fig. 5) severely damaged by the soybean cyst nematode. Right - a normal plant.





Fig. 3. Abundant female nematodes on the roots of a soybean plant taken from an 80-acre field (fig. 5) in southeastern Missouri in 1959.

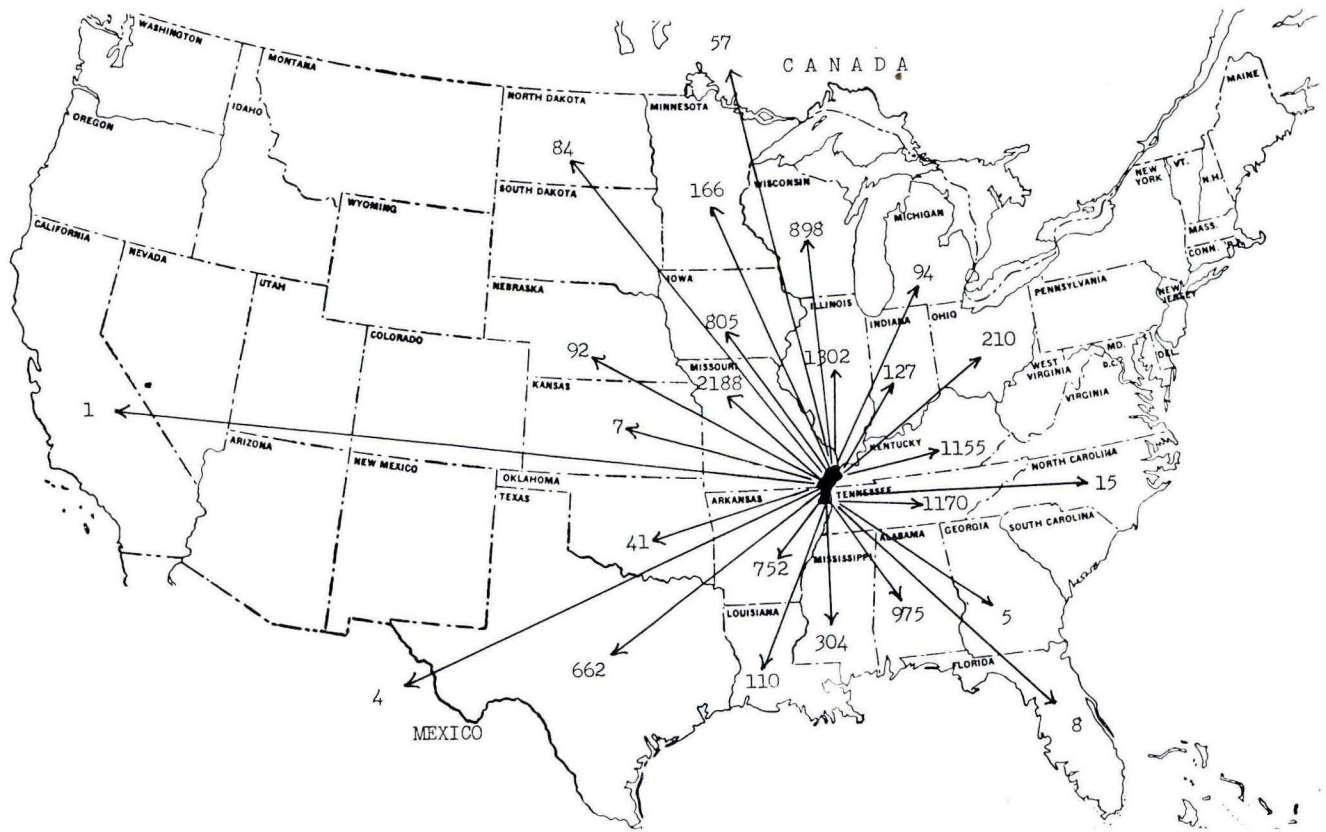

Fig. 9. Distribution of farm machinery and other equipment certified for movement from the soybean-cyst-nematode-quarantine area in Missouri during fiscal year 1966. The total was 11,232 items.

Regional Deployment for Conservation of Oat Crown-Rust Resistance Genes¹

by J. Artie Browning, M. D. Simons,
K. J. Frey, and H. C. Murphy²

ABSTRACT

Widespread production in North America of oat cultivars with the same resistance genes has resulted in a rapid turnover of oat cultivars and rust races. Central North America is an epidemiological unit for wind-disseminated continental pathogens such as the cereal rusts. These fungi overwinter in the South and move north into the upper Mississippi River Valley and Canada in the spring. Barberry and buckthorn eradication unified this vast area epidemiologically for stem and crown rust. In theory, the logical step sequential to eradication of the alternate hosts, therefore, is to deploy rust resistance genes so that those utilized in commercial cultivars in the northern USA and Canada differ from those utilized in the southern USA and northern Mexico. This should block the successful seasonal interregional movement of rust spores that has jeopardized crops in both the North and the South. Interregional movement of spores would still occur, but the spores should be of races avirulent on crops in the other region, forcing the fungi to recycle between incompatible hosts.

Only effective, uncommitted resistance genes are subject to deployment. There is an adequate number of such genes for oat crown rust on hand or on the horizon. Used wisely as part of an integrated continental control program, these should last indefinitely. Therefore, intra- and interregional research should be undertaken to test the validity of this theory. If valid, an integrated continental program for conservation of resistance genes while using them to control crown rust of oats could be developed through work and agreement of small-grain workers.

INTRODUCTION

Oats (*Avena sativa* L.) contrasts to other important annual crops in Iowa in that its major pathogens, *Puccinia graminis* Pers. f. sp. *avenae* Erikss. & Henn., *P. coronata* Cda. var. *avenae* Fraser & Led., and the barley yellow-dwarf virus, are borne over great distances by the wind directly, or indirectly by winged aphids. As a result, how extensively a genotype is grown is more important than how intensively it is cultivated on a given square foot of land. Only the future can tell the impact of culturing corn and soybeans intensively; we can look to the past to learn the disease consequences of culturing single genotypes of oats extensively.

Unlike other small grains, the area in which a given oat cultivar has been grown has been

determined primarily by its range of adaptation, not by market considerations. Therefore, single oat cultivars have been grown over extensive acreages, and single-resistance genotypes over most of a continent. This has had a marked influence on the composition of the pathogen population and offers an excellent example of the consequences of extensive culture of genotypes lacking diversity for disease reaction. Data from Iowa, located in the midst of the extensive oat-producing area of North America, illustrate the magnitude of the problem. Further examination of the epidemiology of rust in this extensive geographical area suggests a solution.

INTERRELATIONSHIP OF OAT CULTIVARS AND RUST RACES

The effect of the extensive culture of oat genotypes on the racial dynamics of the oat crown- and stem-rust fungi, and vice versa, is shown in fig. 1 (21). The cultivar change for Iowa is representative of the North Central Region. In 1941, some 99% of the Iowa oat acreage was sown to 'Richland' and similar crown-rust-susceptible cultivars that originated as pure-line selections. By 1945, Victoria-Richland derivatives, the first important oat cultivars of hybrid origin, occupied

¹Journal Paper No. J-6261 of the Iowa Agriculture and Home Economics Experiment Station, Ames, Iowa. Project 1752. Co-operative investigations with the Crops Research Division, ARS, USDA.

²Professor of Plant Pathology, Iowa State University, Ames, Iowa; Plant Pathologist, Crops Research Division, ARS, USDA, Ames, Iowa; Professor of Plant Breeding, Iowa State University, Ames, Iowa; and Leader (deceased July 20, 1968), Oat Investigations, Crops Research Division, ARS, USDA, Beltsville, Maryland.

about 92% of that acreage, and Marion, 5.5%. A "new" pathogen, *Helminthosporium victoriae* Meehan & Murphy, virulent on the Victoria derivatives, appeared dramatically and caused losses to the Iowa oat crop estimated at 5, 25, 32, and 1% in 1945, 1946, 1947, and 1948, respectively, with similar losses occurring in certain other states. Victoria derivatives were replaced rapidly by blight-resistant Bond derivatives. The Bond acreage in Iowa increased from 0.05% in 1945 to 98% in 1949, and a single oat cultivar, 'Clinton,' occupied 75% of the total oat acreage of the USA in 1950.

In 1945, at their peak, there were about 6.7×10^{12} Victoria-Richland-derived plants distributed on 5.2 million acres in Iowa. By 1948, this had shifted to 7.3×10^{12} plants of Clinton on 5.6 million acres. Such a sudden and complete shift in cultivars polar in disease response caused parallel shifts in pathogenic strains of the pathogen population (fig. 1).

The Victoria derivatives were resistant to *P. graminis avenae* races 1, 2, and 5, but susceptible to previously rare races 8 and 10. Expectedly, races 8 and 10 increased and comprised 45% of the stem rust cultures identified nationally in 1946. As Victoria derivatives were forced from production by *H. victoriae*, itself a product of an extensive, homogeneous host population, Bond derivatives increased. These were resistant to races 8 and 10, but susceptible to race 7. After a lag of about 2 years, the increase of race 7 paralleled that of Bond derivatives, peaking at over 80% of the total isolates in the major epiphytotic year

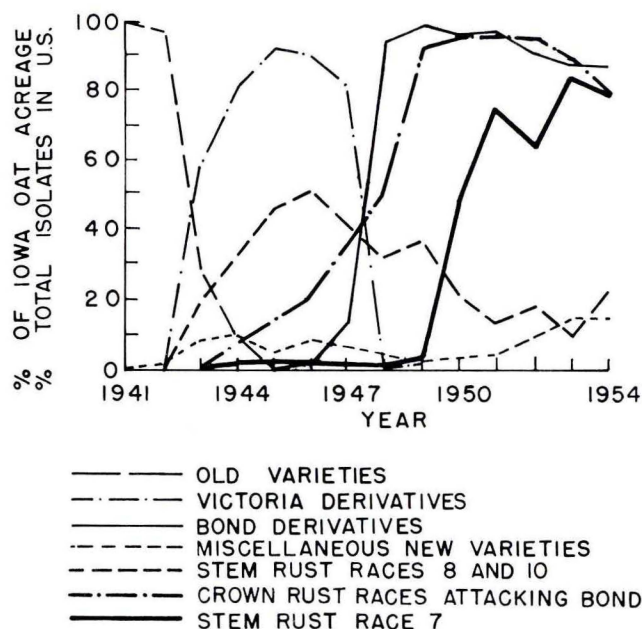

Fig. 1. Percentage of Iowa oat acreage planted to cultivars of different origin, and percentage of total United States' isolates of crown and stem rust races identified during 1941-54, inclusive. After H. C. Murphy, 1965. Protection of oats and other cereal crops during production. pp. 99-113. In: AAAS Publ. 77.

of 1953. The Bond derivatives also selected for crown-rust races virulent on them. Identification of cultures virulent on Bond derivatives, which earlier had been considered highly resistant to crown rust, began in quantity in 1943 from experimental plots and increase fields. Once commercial production of Bond lines commenced, races of *P. coronata avenae* pathogenic on Bond quickly jumped to over 95% of all cultures of crown rust identified in the USA. The Bond resistance was then supplemented with the resistance of Landhafer, but crown-rust races parasitizing Landhafer soon appeared and rapidly increased in prevalence to a point where the Landhafer resistance was rendered ineffective. These racial dynamics adequately illustrate the point that the pathogen response can be "causally related to the man-made modification of their hosts" (18).

Because of *H. victoriae* and the wide areas in which the individual oat cultivars may be adapted agronomically, the race-cultivar-time lines were drawn rather sharply with oats. But otherwise, the experience with oats is representative of that with other small grains wherever specific resistance has been used—the USA, Canada, Mexico, Australia, Kenya (18).

New resgenes [resistance genes (36)] have commonly been incorporated into new cultivars on the background of previous resgenes and, generally, not until previous genes became ineffective. Following the stepwise incorporation of resgenes, the pathogen has incorporated virulence genes [virulence genes (4)] into its population in corresponding stepwise fashion. Watson and Singh (36) proposed that, instead of this breeding procedure, cultivars be developed with two resgenes, each of which conditioned resistance to all local races. They reasoned that it would be highly improbable that a new race could arise that had acquired virulence at two loci simultaneously. To be effective, this procedure would require that the resgenes in question never be used singly within a given epidemiological area. Even so, there is the possibility that susceptible cultivars of the same crop or wild gramineous hosts (e.g., *Hordeum jubatum* L.) could carry mutants for single loci and that additional virulence combinations could develop (7).

The proposal by Watson and Singh (36) still is in the direction of attempting to shut out the fungus entirely by discovering that single, resistance genotype of "greatest value" (1) and growing it for sustained, maximum yields under pest-free and disease-free conditions. Such conditions do not exist in nature, and attempting to establish them under cultivation probably is no more possible for major pests and pathogens than it has been for weeds. A popular theory that genes from distant relatives of cultivated crops can be incorporated into commercial cultivars and utilized indefinitely is not tenable. In the classical work of Sears (27), a gene conditioning resistance to all known races of *Puccinia recondita* Rob. ex Desm. was transferred to wheat from *Aegilops umbellulata* Zhuk. Even before this resistance could be utilized in

commercial production, races of wheat leaf rust appeared that parasitized the resistant wheat in Argentina (24). Similarly, a high type of resistance to oat crown rust is conditioned by a gene from *Avena sterilis* L. 'Wahl No. 2.' This was transferred to Iowa oat line X-421, a multiline-variety component. Before this gene appeared in a commercial cultivar, we discovered a race of crown rust highly virulent on X-421.

We know now, after almost 4 decades of experience, that the fungus probably can come up with a virulence to counteract each major resistance gene that we release, regardless of its source. Must we continue in this direction, or is there an alternative? This paper was written to suggest that, utilizing current information in light of past experience, we can develop a program of gene utilization and conservation through a coordinated and integrated continental control program.

OTHER TYPES OF RUST RESISTANCE

Attempting to shut out the fungus with that single, resistance genotype of "greatest value" (1) also is inimical to the philosophy behind generalized, or horizontal resistance; namely, that the pathogen is not eliminated, but the epiphytotic is. The host may not, in fact, be resistant at all, as usually indicated by visible infection type. "Resistance" may be manifested by a low level of rust infection or by delayed rust buildup (35) so that yield is maintained at a high (but not necessarily the highest), stable level. Van der Plank (35) and Caldwell (8) have advanced convincing arguments that such resistance is the most promising means of rust control. Hooker (14)³ has shown this to be the phenomenon effective in protecting corn in an extensive area of North America where corn is abundant, the environment is favorable, and rust is present but of no economic importance. Obviously, we should search diligently for this type of broadly based generalized resistance in small grains.

Sources of tolerance (10, 30), which probably is an entity separable from resistance (14), also are available. Pure-line generalized resistance and tolerance are conceptual and difficult to work with, however, and only time and research can tell if these two phenomena offer the requisite panracial protection from rust (4).

Certain sources of adult-plant resistance were once hopefully thought effective against all crown-rust races (22). It now appears, however, that such resistance is basically similar, in terms of race specificity, to seedling resistance (29). Thus, it would be expected to behave like vertical resistance epidemiologically.

GENETIC DIVERSITY

Diversity offers a means of utilizing all types of resistance in a coordinated, integrated control program.

Diversity was once the rule by which everything operated in nature. Then, with cultivation, man

began controlling weeds and thus made his crops more homogeneous. The population of a given cereal crop remained genetically very diverse, however, until 6 or 7 decades ago when man began pure-line selection. Instead of having a genetically diverse crop, he then had a genetically homogeneous crop. There still was diversity between areas, however. Breeders at Winnipeg, Manitoba, might select a locally well-adapted oat or wheat cultivar. This would be repeated in each state from Minnesota to Texas. The cultivars selected as locally adapted would constitute the local, relatively homogeneous crop. However, it was a genetically diverse crop as far as pathogenic organisms in the entire area were concerned. But then hybridization began, and widespread distribution of resistance genes like the Hope gene for wheat stem-rust resistance and the Bond gene for oat crown-rust resistance followed. With oats, for instance, Stanton, Coffman, and Murphy made Iowa a focus from which a few resistance genes radiated far and wide (19). Many derived lines initiated in Iowa were tested around the country, and one adapted in a distant state might be named and released there. 'Clarion' was developed in Iowa and released in Maine. Where existing strains were not adapted locally, Bond or a Bond derivative was hybridized with a local variety. Thus, the Bond gene was utilized up, down, across, and beyond the Mississippi basin. If homogeneity caused the problem, diversity promises an answer.

Intravarietal Diversity

Diversity can be intra- or intervarietal, and intra- or interregional. Although intervarietal diversity seems superior to present practice, intravarietal diversity seems to us still better. Intravarietal diversity in self-pollinated crops can best be achieved through development of multiline cultivars.

Multiline varieties were proposed by Jensen (15) for oats and by Borlaug and Gibler (3) for wheat. They are being developed in Colombia (24), Mexico (2), New York (16), and Iowa (4). Named multiline cultivars, released in three series, are: 'Miramar 63' and 'Miramar 65' wheat from Colombia (24, 25) and, from Iowa (4), 'Multiline E68' and 'Multiline E69,' in an early oat series, and 'Multiline M68' and 'Multiline M69,' in a midseason oat series.

The Iowa multiline cultivars are mechanical mixtures of 8 to 10 different isogenic lines. Each line contains a different gene for vertical resistance. The mixture of vertically resistant lines gives a cultivated unit, a multiline cultivar, which behaves as if it were a pure-line cultivar with generalized or horizontal resistance.

Browning and Frey (4) summarized advantages of multiline cultivars as follows: "(a) They provide a mechanism to synthesize instant, well-buffered, horizontally resistant cultivars which, unlike pure-line cultivars, can utilize without difficulty several resistance genes at the same locus or resistance genes which happen to be linked in the repulsion phase. (b) They should extend indefinitely the useful life of a given

³ See also Hooker's paper in this special report.

resgene and enable a resistance breeding program eventually to be reduced in size while the breeder carries on parallel improvement in the recurrent parent. (c) Removing the rust hazard should stabilize the cultivars used and enable farmers to optimize production for a given multiline cultivar on a given farm. (d) They offer a means whereby a center of variety development can distribute host cultivars far and wide without risk of homogenizing the pathogen on a global scale."

As promising as our multiline cultivars appear, especially for gene conservation, their real test will come only after they are grown over an extensive commercial acreage in Iowa and contiguous states. Unfortunately, however, Iowa and contiguous states are not the unit for rust epidemiology and control.

Interregional Diversity

Residual vs. continental pathogens.

A basic dichotomy in the epidemiology of plant diseases is whether the pathogen is *residual* or *continental*. We consider a pathogen residual if it can perpetuate itself locally; i.e., within a given relatively small area—be it a state, county, farm, or flowerbed. A disease caused by a residual pathogen (e.g., fire blight, wheat bunt, brown stem rot of soybeans, corn stalk rot, or root knot) can be influenced by the grower(s) affected. A continental pathogen, on the other hand, like a continental climate, originates outside the area, covers large areas, and local growers are at the mercy of whatever blows their way.

Rusts of small grains have capacity to be either residual or continental, but eradication of the alternate hosts has made *P. graminis* and *P. coronata* almost exclusively continental pathogens in mid-America.

The epidemiological unity of the Puccinia Path.

Hamilton and Stakman (13) state: "The South and the North are mutually supplementary in the annual development of wheat stem rust in a vast area of North America extending from Mexico through the Mississippi basin of the USA and onward to the prairie provinces of Canada, a distance of some 2,500 miles."

This area, the great heartland of North America, hereinafter referred to as the "Puccinia Path," is the epidemiological unit for rust control.

"As the uredial stage of the rust seldom survives the winter north of central Texas, the area northward is dependent on Texas or Mexico for most of the initial inoculum early in the growing season, especially since barberries (*Berberis vulgaris* L.) have been largely eradicated from the north-central states, where they once abounded. Conversely, the uredial stage of the rust seldom survives the long, hot summer in Texas and northern Mexico between the wheat harvest in the spring or very early summer and the autumn sowing of winter wheat. That area is then dependent on the northern areas for windblown inoculum in the fall" (13).

Crown rust and buckthorn (*Rhamnus cathartica*

L.) closely parallel stem rust and barberry. Buckthorn eradication was not required by law in Iowa until 1955, but has now advanced until buckthorn no longer is a factor in epiphytotics in Iowa (except possibly on a local scale).

Barberry (35) and buckthorn eradication did the job they were designed to do. They removed sources of early spring inoculum and sources of new races. But possibly the most important contribution of these programs was to unify the Puccinia Path epidemiologically. *P. graminis* and *P. coronata* are no longer residual pathogens, able to survive and recycle in many farm or county units in the North; the entire Puccinia Path is the unit. The ability of these fungi to make the transition from residual to continental pathogens has enabled them to continue as threats to small-grain production in the Puccinia Path.

Evidence for the epidemiological unity of the Puccinia Path comes from several sources: (a) The sequence of rust development and the movement of windborne spores are from south to north in summer and north to south in fall (31). (b) Since north-south spore movements up and down the Puccinia Path are the rule, while east-west movements outside this area are uncommon (31), pathogenic races, identified from the population of rust in the Puccinia Path should be similar from south to north, but different races might be expected to occur outside the area. Races of *P. coronata* (20) and *P. graminis* (e.g., 12, 32) identified from the northeastern USA, eastern Canada, and western North America differ from those identified in the Puccinia Path, indicating that these areas are in separate spore-distribution systems. (c) The existence of the Puccinia Path as the unit has resulted in the selection of strains of the pathogens best adapted for the average conditions of the entire area, not just for isolated areas. In the Colombian Andes, for instance, the oat crown- and stem-rust fungi may occur in "pockets," and races in one pocket may differ from those in another. Further, the temperature requirement of cereal rusts there may differ a great deal from that of a rust fungus adapted to life as a continental pathogen. In Colombia, the oat crown- and stem-rust fungi caused infection on plants inoculated and left outdoors overnight when the temperature dropped to freezing, and they were able to cause severe rust epiphytotics even though temperatures in the field seldom rose above the 21 C considered optimum for rust development in the Puccinia Path (Browning and Elkin Bustamante-R, unpublished).

(d) Additional and highly interesting corroborative evidence on the unity of the Puccinia Path comes from work with barley yellow dwarf. Like crown and stem rust, the barley yellow-dwarf virus (BYDV) can be considered both a residual and a continental pathogen. Severe epiphytotics of yellow dwarf result in the Mississippi basin when the BYDV acts as a continental pathogen transported by continental vectors (6). Paralleling the rust-race situation, strains of the BYDV in New York differ from those in Illinois. Furthermore, nonspecific BYDV strains predominated in Illinois as com-

pared with New York, and vectors from Illinois may be less strain-specific than those in New York (23). Vector nonspecificity, the result of the kind of virus and (or) vector in the area, evidently is the rule in Washington (5), Kansas (26), North Dakota (34), and Illinois (23, 33), but a rare phenomenon in New York (23).

Clearly, the Puccinia Path being the unit has resulted in the selection of strains of viruses, their vectors, and rust fungi with maximum adaptability to the plants and environment encountered in the Puccinia Path. The BYDV in this area is literally "able to 'ride' with whatever grass aphid comes along" (5), and aphids and rust spores must be able to "ride" whatever wind comes along and excel under many different environmental conditions and on many hosts if they are to be serious threats to small grain production in central North America. They are best adapted for the average conditions they are likely to encounter (e.g., temperature) from south to north, and from winter crops to spring-sown crops.

Breaking the unity of the Puccinia Path.

Recognizing (a) that the Puccinia Path is now a single, functional epidemiological unit for cereal rusts, (b) that it must be maintained if the rust fungi are to remain serious threats, (c) that unity of the Puccinia Path will continue inviolate as long as the rust fungi can recycle between compatible hosts growing in the summer and winter areas, and (d) that forcing the fungi to recycle between incompatible hosts will break the cycle, suggests the logical sequel to barberry and buckthorn eradication; namely, interregional diversification by deployment of different resgenes north and south to break the unity of the Puccinia Path.

Delimiting north and south regions should be done by agreement based on future field observations and research. Each year, there is a certain line of demarcation, south of which a given rust fungus overwinters, and, north of which, it does not. Weather conditions determine the location of that line, which may vary from year to year and for different rusts. With *P. recondita*, the line may be across central Iowa because this fungus can survive winters wherever winter wheat survives. But for *P. coronata* and *P. graminis*, the line is far south, probably somewhere across central Texas. South of this line, hereinafter called the Puccinia Line, at the coldest part of the year, these rusts are forced by winter into their smallest geographical areas. There they can overwinter independent of what happens to the north. Zone 1, certainly, should be south of the Puccinia Line. A minimum of one other zone, consisting of everything north of that line, would be possible. It might be preferable, however, to have a third zone (Zone 3) to coincide with the area where late spring oats are adapted—the prairie provinces of Canada and contiguous areas of extreme north-central USA. An intermediate zone (Zone 2), consisting of most of the Mississippi basin, would then lie in between.

Deployment of resgenes.

Van der Plank (35) stated: "The chemical industry and plant breeders forge fine tactical weapons; but only epidemiology sets the strategy. . . . We must review the strategy, as distinct from the actual tactics in battle, against plant disease."

Reviewing our strategy in light of our knowledge of the interdependent parts of the Puccinia Path tells us that, if we have the necessary resgenes, we should deploy each one for use in—and only in—one of the two or three designated zones.

The idea of such interregional diversity of resgenes is not new. E. S. McFadden, who studied rust behavior in the Puccinia Path first in South Dakota and then in Texas, appears to have been the first to conceive the idea. According to I. M. Atkins (personal communication), among the places McFadden expressed his proposal were in letters dated May 19, 1943, and July 14, 1943, to T. R. Stanton. In these, he suggested that, if combined resistance to oat stem rust were not possible, then "the next best bet would be to set up zones across the oat-growing regions in which resistance to specific races would be used in each zone." He believed that combining resistance to all races would be a slow process and that new races might arise to negate the combined resistance. Although he clearly had wheat as well as oats in mind, his specific proposal was that oats resistant to *P. graminis avenae* races 8 and 10 be grown in the South. Then, he continued, "we possibly would have little trouble from rust in the future since inoculum of the other races will ultimately be eliminated in the North through growing of the Richland derivatives. Likewise, there might be little trouble from rust in the North since races 8 and 10 would be eliminated in the South."

McFadden's proposal was poorly received, partly because some thought that spores would blow over one zone and into another (evidently, he visualized fairly narrow zones), but mainly because of the optimism that combined resistance to all races could be obtained and maintained without resorting to a more naturally balanced and integrated continental control program. The failure to obtain and maintain combined resistance has brought additional suggestions for interregional diversity (4, 9, 15, 17, 28, 35, 37).

"Use of varieties on a national or regional basis" was one type of diversity suggested by Jensen (15). Johnson (17) proposed discussions on the regional distribution of genes for rust resistance.

Van der Plank (35) suggested that, where the route of an epiphytotic is known, genes for vertical resistance should be added to the varieties where the epiphytotic ends, but not where it starts. This would give maximum opportunity for selection of simple races (races with few virulenes) against which the genes for vertical resistance would be effective. Assuming that the epiphytotic begins in the South, since the disease covers a smaller area for a longer time during the winter months, simple varieties (varieties with few resgenes), then, would be sown there, and more complex varieties would

be sown in the North. Even though this probably would result in no more rust loss than is experienced with current practices, it is unlikely that simple cultivars would be acceptable as sole protection from rust pathogens in that area. For this reason, we suggest that, where available, as for oat crown rust, adequate numbers of resgenes be deployed so that complex varieties can be bred in each area, but by using different resgenes.

Workers in each state would be free to determine how to use the genes deployed for use in their zone. We would suggest that the genes be used in multiline cultivars. If this were done and different genes were deployed in each area, the rust fungus would be expected to multiply less rapidly in each area and produce fewer spores to endanger the crop elsewhere (11). Not only that, but spores that did increase successfully in one area would be avirulent on the crop in other areas. Thus, crown rust should be delayed or excluded out of existence or, at least, be reduced to a level of little or no economic importance.

How many resgenes would be required to accomplish this? Theoretically, only two. The minimum would be one resgene in the South that did not occur in the North, and one in the North that did not occur in the South. In actuality, two resgenes probably would not be nearly enough. Although data are lacking, it appears to us likely that, even if three or four resgenes were used in the South and an equal number of different resgenes in the North, the versatile fungus might bridge the gap. We propose, therefore, that, if possible, 8 or 10 different resgenes be deployed for utilization in each zone.

Tests of interregional diversity.

Interregional diversity in North America has passed limited tests successfully. The first test was possible because of the widespread use of single oat genotypes. In the early 1940's, when the Victoria-Richland oat derivatives (resgene A) were grown widely in the USA and western Canada, *P. graminis avenae* races 8, 10, and 11 increased on them in damaging proportions. *Helminthosporium victoriae* caused USA (but not Canadian) breeders to shift from the Victoria-Richland derivatives to Bond derivatives (resgene D), which were resistant to races 8, 10, and 11 but susceptible to race 7. Race 7 soon increased on the Bond derivatives in the USA (fig. 1). Gene A protected the Canadian oat crop from race 7 that blew into Canada, and gene D prevented the race 8 group from increasing in the central states and damaging the Canadian crop (17). Thus, this unplanned deployment of stem rust resgenes served to protect the Canadian crop by forcing the pathogen to recycle between incompatible hosts, but the line of demarcation was too far north to protect the USA crop.

In an unplanned test in Indiana (9), where leaf rust seldom overwinters, 'Vigo' wheat possessed the Fultz type of leaf-rust resistance, which was different from that in other Indiana wheats or in

wheats to the south. Races virulent on the Fultz resistance in Vigo were not selected in the primary epiphytotic area (35) to the south, and Vigo remained free of rust damage even in severe leaf-rust years.

Europe also has provided a test of interregional diversity (37). That continent's political and geographical situation has resulted in the development of many national wheat cultivars. These usually differ for reaction to *Puccinia striiformis* West. and, depending on their adaptation and popularity, might be planted over limited or extensive geographical areas. In some instances, races virulent on certain cultivars grown over a limited area are confined to that area; limitations on the area of production of compatible hosts prevent such races from coming in from other areas and also from moving out of them. On the other hand, a few popular, broadly adapted cultivars have been planted over a wide area, and these have facilitated the widespread distribution of races to which they are susceptible. Zadoks (37) concluded that, because of the danger of long-distance spore dispersal to wheat culture in Europe, the cultivation of each wheat cultivar "should be restricted to a relatively small area."

Proposal for planned deployment of oat crown rust resgenes.

It is obvious that only effective, uncommitted resgenes are subject to deployment among workers in different zones and that gene deployment is indicated only against those continental pathogens for which an adequate number of resgenes is available, such as wheat stem rust (2, 24, 25) and oat crown rust. Adequate numbers of resgenes are not now available for oat stem rust. Our proposal is for oat crown rust.

We propose that intra- and interregional research be undertaken to further test the validity of this theory; if the theory proves valid, perhaps oat workers can agree to a means of delimiting the geographical area in which resgenes can be utilized in commercially grown cultivars.

We have crossed about 25 crown-rust resgenes into two recurrent lines. We have used 15 different genes in one or both of two series of multiline cultivars. Nine of these 15 have not been used previously in cultivars for commercial production. We have an additional 10 or more resgenes in recurrent lines not yet utilized in commercial cultivars. Additionally, many more resgenes are becoming available from *A. sterilis* and other wild oats (38). This may be one of few moments in history when enough different, effective, and uncommitted crown-rust resgenes are available for release or incorporation into commercial cultivars at one time to plan their deployment. As part of an integrated continental control program, our present inventory of genes should last indefinitely. If, instead, they are used piecemeal, history will repeat itself, and the usefulness of each gene, when used over a wide area, will, in time, be lost. Thus, the time for research and decision on how to "use"

the nine resgenes we are releasing, the 10 or more additional genes not yet released, and the many uninvestigated genes is limited. The decision should be made before the genes are committed to commercial cultivars from which they cannot readily be recalled.

Planned gene deployment, as part of an integrated continental program of use and conserva-

tion of resistance genes against continental pathogens, should undergird other programs, whether those utilize generalized resistance, specific resistance, tolerance, or combinations of them possibly with fungicides. We invite discussion and ideas from small-grain workers upon the subject of limiting the geographical areas in which resgenes, especially those against oat crown rust, will be used.

REFERENCES CITED

- Allard, R. W., and P. E. Hansche. 1964. Some parameters of population variability and their implication in plant breeding. *Adv. in Agron.* 16:281-325.
- Borlaug, N.E. 1959. The use of multilineal or composite varieties to control airborne epidemic diseases of self-pollinated crop plants. pp. 12-26. In: *First Int. Wheat Gen. Symp. Proc.*, Winnipeg.
- _____, and J. W. Gibler. 1953. The use of flexible composite wheat varieties to control the constantly changing stem rust pathogen. *Agron. Abstr.* p. 81.
- Browning, J. Artie, and K. J. Frey. 1969. Multiline cultivars as a means of disease control. *Ann. Rev. Phytopathol.* 7:355-382.
- Bruehl, G. W. 1958. Comparison of eastern and western aphids in the transmission of barley yellow dwarf virus. *Plant Dis. Rptr.* 42:909-911.
- _____. 1961. Barley yellow dwarf, a virus disease of cereals and grasses. *Amer. Phytopathol. Soc. Monogr.* 1. 52 pp.
- Bugbee, W. M., R. F. Line, and M. F. Kernkamp. 1968. Pathogenicity of progenies from selfing race 15B and somatic and sexual crosses of races 15B and 56 of *Puccinia graminis* f. sp. *tritici*. *Phytopathology* 58:1291-1293.
- Caldwell, R. M. 1966. Advances and challenges in the control of plant diseases through breeding. pp. 117-126. In: *Pest control by chemical, biological, genetic, and physical means.* (Proc., AAAS Symposium). U. S. Dept. Agr., Agr. Res. Serv. Misc. Publ. 33-110.
- _____, J. F. Schafer, L. E. Compton, and F. L. Patterson. 1957. A mature-plant type of wheat leaf rust resistance of composite origin. *Phytopathology* 47:690-692.
- _____, and _____. 1958. Tolerance to cereal leaf rusts. *Science* 128:714-716.
- Cournoyer, Blanche M. 1967. Crown rust intensification within and dissemination from pure line and multiline varieties of oats. Unpublished M. S. thesis. Iowa State University Library, Ames. 70 pp.
- Green, G. L. 1966. Stem rust of wheat, rye and barley in Canada in 1965. *Can. Plant Dis. Surv.* 46:27-32.
- Hamilton, Laura M., and E. C. Stakman. 1967. Time of stem rust appearance on wheat in the western Mississippi basin in relation to the development of epidemics from 1921 to 1962. *Phytopathology* 57:609-614.
- Hooker, A. L. 1967. The genetics and expression of resistance in plants to rusts of the genus *Puccinia*. *Ann. Rev. Phytopathol.* 5:163-182.
- Jensen, N. F. 1952. Intra-variety diversification in oat breeding. *Agron. J.* 44:30-34.
- _____, and G. C. Kent. 1963. New approach to an old problem in oat production. *Farm Res.* 29:4-6.
- Johnson, T. 1958. Regional distribution of genes for rust resistance. *Robigo* 6:16-17.
- _____. 1961. Man-guided evolution in plant rusts. *Science* 133:357-362.
- Jones, E. T. 1949. The breeding of disease-resistant varieties of oats. *Empire J. Exp. Agr.* 17:199-214.
- Michel, L. M., and M. D. Simons. 1966. Pathogenicity of isolates of oat crown rust collected in the USA, 1961-1965. *Plant Dis. Rptr.* 50:935-938.
- Murphy, H. C. 1965. Protection of oats and other cereal crops during production. pp. 99-113. In: *AAAS Publ.* 77.
- Peturson, B. 1944. Adult plant resistance of some oat varieties to physiologic races of crown rust. *Can. J. Res., Sect. C*, 6:287-289.
- Rochow, W. F., H. Jedlinski, B. F. Coon, and H. C. Murphy. 1965. Variation in barley yellow dwarf of oats in nature. *Plant Dis. Rptr.* 49:692-695.
- Rockefeller Foundation. 1963. Program in Agr. Sci., *Ann. Rpt.* 1962-63. 310 pp.
- _____. 1965. Program in Agr. Sci., *Ann. Rpt.* 1964-65. 262 pp.
- Saksena, K. N., W. H. Sill, Jr., and J. M. Kainiski. 1964. Relative efficiency of four aphid species in the transmission of Kansas isolates of barley yellow dwarf virus. *Plant Dis. Rptr.* 48:756-760.
- Sears, E. R. 1956. The transfer of leaf-rust resistance from *Aegilops umbellulata* to wheat. *Brookhaven Symp. in Quant. Biol.* 9:1-22.



28. Simmonds, N. W. 1962. Variability in crop plants, its use and conservation. Biol. Rev. (Cambridge) 37:422-465.
29. Simons, M.D. 1961. Testing oats in the field with specific races of crown rust. Proc. Iowa Acad. Sci. 68:119-123.
30. _____. 1966. Relative tolerance of oat varieties to the crown rust fungus. Phytopathology 56:36-40.
31. Stakman, E. C., and J. G. Harrar. 1957. Principles of plant pathology. Ronald Press, N.Y. 581 pp.
32. Stewart, D. M., R. U. Cotter, B. J. Roberts, and J. J. Christensen. 1959. Physiologic races of *Puccinia graminis* in the United States in 1958. Plant Dis. Rptr. (Suppl.) 258:189-196.
33. Takeshita, R. M. 1956. Identity of the oat red-leaf virus with the barley yellow-dwarf virus. Phytopathology 46:436-440.
34. Timian, R. G., and G. L. Jensen. 1964. Absence of aphid species specificity for acquisition and transmission of a strain of barley yellow dwarf virus. Plant Dis. Rptr. 48:216-217.
35. Van der Plank, J. E. 1963. Plant diseases: Epidemics and control. Academic Press, N.Y. 349 pp.
36. Watson, I. A., and D. Singh. 1952. The future for rust resistant wheat in Australia. J. Aust. Inst. Agr. Sci. 18:190-197.
37. Zadoks, J. C. 1961. Yellow rust on wheat. Studies in epidemiology and physiologic specialization. Tijdschr. Plantenziekten 67:69-256.
38. Zillinsky, F. J., and H. C. Murphy. 1967. Wild oat species as sources of disease resistance for the improvement of cultivated oats. Plant Dis. Rptr. 51:391-395.