

17-H53R  
9: L744

Iowa Highway Research Board

Project HR - 74

LIVE LOAD DEFLECTIONS IN A  
PRESTRESSED STEEL BEAM BRIDGE

Prepared by

Neil Welden

Iowa State Highway Commission

December, 1963

ABSTRACT

This report describes the measurement of dynamic (live load) deflections in a 240' x 30' three span continuous prestressed steel bridge, skewed 30°. The design assumptions and prestressing procedure are described briefly, and the instrumentation and loading are discussed. The actual deflections are presented in tabular form, and the deflections due to the design live load are calculated. The maximum deflections are presented as a ratio of the span length, and the further use of prestressed steel beams is recommended.

LIVE LOAD DEFLECTIONS IN A  
PRESTRESSED STEEL BEAM BRIDGE

By Neil Welden

The subject of this investigation is a 240' x 30' three span continuous prestressed steel beam bridge, skewed 30° clockwise, over Silver Creek on US Highway No. 6 in Pottawattamie County, Iowa. The spans are 73'3 - 93'6 - 73'3. The slab is supported by four lines of beams, spaced 9'8 center to center, spliced 22'0 each side of each interior support, near the point of dead load contraflexure. The exterior beams are 30" wide flange 108#, and the interior beams are 33" wide flange 130#. All beams are A.S.T.M. A-36 steel, and all have high strength steel <sup>(1)</sup> cover plates. The design live load is AASHO H20-S16-44. Live load moments causing tension in the bottom flange and compression in the top flange of the beams are resisted by composite action of the beam and slab. The structure will hereafter be referred to as the Silver Creek bridge.

The prestressing principle used in this structure was conceived by Mr. P. F. Barnard, Structural Engineer in the Bridge Design Division of the Iowa State Highway Commission,

(1) USS T1, a quenched and tempered weldable alloy steel, which has a yield strength of 100,000 psi and a working stress of 55,000 psi.

in July 1960. Briefly, it consists of loading a beam by jacking to produce stresses, below the elastic limit, opposite in sense to those produced by structural loads. With the beam so stressed, a T1 cover plate is welded to the compressed flange of those beams which will resist live load moments by composite action with the slab, and T1 cover plates are welded to both flanges of those beams in which composite action is not considered effective. The load is then released, producing stresses in the beam and cover plate which are the same as those produced in the cover plated beam by a load equal in amount, and opposite in direction, to the jacking load.

Since all stresses are below the elastic limit, the resultant stresses in the beam and cover plate are the algebraic sum of the jacking stress and the release stress. The resultant stresses in the beam are opposite in sense, and in the cover plate identical in sense, to the stresses caused by structural loads. In the structure, the structural loads first reduce the resultant stresses in the beam to zero, and then increase them to the working stress in the opposite sense. The resultant stress in the cover plates is increased by the structural loads, but the high allowable working stress of the T1 plates enables them to tolerate this increase. If a proper choice of beam section, cover plate size, and prestress loading is made, the maximum stresses under structural loads will approximate the allowable working stresses in the beams and cover plates.

The Iowa State Highway Commission was favorably impressed by the prestressed steel concept, and authorized the Bridge Design Division to use prestressed steel in the design of the Silver Creek Bridge. The United States Bureau of Public Roads considered the concept experimental, and declined the use of Federal funds; the project was therefore made non-participating.

In order to establish fabrication procedures, to determine load deflection characteristics, and to check actual stresses with the analysis, we decided to fabricate prototype beams, and Mr. Barnard designed two, one with a single cover plate, and one with two cover plates, one on each flange. The United States Steel Corp., Bethlehem Steel Co. and Inland Steel Co. furnished the material, and the beams were fabricated in the Des Moines, Iowa shops of the Pittsburgh-Des Moines Steel Co., with a group of fabricators <sup>(2)</sup> sharing the cost.

The first pair of beams were prestressed by jacking, blocked in that position, and the cover plates completely welded to the beams. The results were disappointing, since the distortion due to welding while the beam was held by the blocks reduced the prestress considerably. Mr. Barnard suggested that this effect could be minimized by prestressing the beams and tack welding the cover plates to them, using only sufficient weld metal to

(2) American Bridge Division of the US Steel Corp., Clinton Bridge Division of the Allied Structural Steel Co., Des Moines Steel Co., Missouri Valley Steel Co., and Pittsburgh-Des Moines Steel Co.

assure interaction between the beams and cover plates. The prestress load would then be released, and the weld completed with the beams free to deflect. A second pair of beams was fabricated in this manner, and strain gage measurements showed that the stresses agreed closely with the analysis.

In order to compare the effect of welding on prestressed and unprestressed beams, material was obtained for another single plated beam, and this beam was fabricated in the shops of the Des Moines Steel Co., Des Moines, Iowa using procedures identical with those used on the single plate prestressed beam, except that the beam was not prestressed.

These three beams - two fabricated by the prestress - tack weld - release - weld procedure and one fabricated without prestress - were taken to the laboratory of the Materials Department of the Iowa State Highway Commission, where they were loaded to determine the load-deflection characteristics. All beams, on first being loaded, showed a small permanent set, but subsequent loads within the same range showed excellent proportionality. No significant difference was found in the performance of the single plate prestressed and unprestressed beams.

Mr. Barnard presented a report to the National Engineering Conference, sponsored by the American Institute of Steel Construction, in Minneapolis, Minn., on May 11, and 12, 1961, dealing with the prestressed steel concept and the fabrication

and testing of the prototype beams. The report was published in the "Proceedings" of that conference.

After the prototype beams had been tested at the Iowa State Highway Commission, they were turned over to the Civil Engineering Department of Iowa State University, Ames, Iowa, where they were subjected to fatigue tests. The results of these tests were published by the Iowa Engineering Experiment Station in a report entitled "Flexural Fatigue Strength of Prestressed Steel Beams" by W. Daniel Reneker and Carl E. Eckberg, Jr., Project 435 S, dated May 1, 1962.

Preliminary designs for the Silver Creek bridge had been made by Mr. R. D. Upsahl and Mr. Domingo Silverio of the Bridge Design Division of the Iowa State Highway Commission. When fabrication and testing of the prototype beams had shown that fabrication was feasible if proper procedures were used, and that the load-deflection characteristics of these beams conformed to the theoretical analysis, the design was completed, and the structure was let on February 14, 1961. W. H. Herberger, Indianola, Iowa, was the successful bidder, and the steel was fabricated by the Pittsburgh-Des Moines Steel Co., in Des Moines, Iowa.

Fabrication was inspected by Mr. Robert Brandser, Mr. Gordon Gwinn, and Mr. Harold Chandler, of the Des Moines laboratory of the Materials Department, Iowa State Highway Commission. Detailed instructions for prestressing, including

jacking loads, anticipated deflections before and after release, and welding details, were included in the design drawings. The beam deflections were checked by a surveyors level telescope attached to one end of the beam sighting a target at the other end and a scale at the center line. When the calculated deflection was reached, T1 cover plates were tack welded in position. The load was then released, and the weld completed. No unexpected difficulties were encountered in fabrication.

Construction was under the supervision of Mr. R. H. Given, District Engineer, with Mr. David Skaff, Resident Construction Engineer, in charge of the project. No special construction procedures were required, except that reasonable precautions were taken to avoid dropping or jarring the beams.

The bridge was completed and accepted on May 10, 1962. It has been in service since that time and is operating satisfactorily. To an observer on the bridge, deflections and vibrations during the passage of a loaded truck are perceptible, but not objectionable.

The AASHO "Standard Specifications for Highway Bridges" limits the computed deflections due to live load and impact to  $1/800$  of the span, where the span is defined as the distance center to center of bearings. For this bridge, the computed deflection due to live load and impact at the center line of the center span is 1.36". The span is 93'6, which gives a ratio of  $1/825$ . This meets the AASHO specification, but the calculation



depends on assumptions of the modulus of elasticity of the concrete, and of the extent of composite action between steel and concrete.

Furthermore, the AASHO specification requires that rolled beams used as girders have a depth greater than  $1/25$  the span, where the span is defined as the distance between points of dead load contraflexure in continuous beams. In this bridge, the exterior beam is slightly more than 30" deep, including the cover plate. The distance from the abutment bearings to the point of dead load contraflexure in the end span is slightly greater than 50', and the distance between points of dead load contraflexure in the center span is slightly less than 50'. This gives a depth to span ratio of about  $1/20$ , which meets the AASHO criterion, but indicates a relatively flexible beam.

Since the computed deflection and the depth - length ratio approach the AASHO specification limit, we considered it advisable to measure the deflections of the bridge under a known live load which approximated, or could be related to, the H20-S16-44 truck used in design. The present project, designated HR-74, was therefore proposed to the Iowa Highway Research Board, recommended by the Board, and authorized by the Iowa State Highway Commission.

The investigation was directed by Mr. Lyman Moothart and Mr. Harold Sharpnack of the Materials Department of the Iowa State Highway Commission. After consulting with Mr. P. F. Barnard and

the author, Structural Engineers for the Bridge Design division of the Iowa State Highway Commission, they decided:

1. Deflections should be measured on one exterior and one interior beam at 29 feet from the center of each abutment bearing and at the center of the center span.
2. A test should be made to check the lateral symmetry of the bridge.
3. The truck should be a five axle vehicle, loaded to approximate, as closely as possible, the AASHO H20-S16-44 truck used in design.
4. Truck speeds should vary from 3 mph (assumed to approximate a static load) to 50 mph (legal speed limit for trucks in Iowa), each run at a constant speed.
5. Runs should be made with the center line of truck at 4.5', 7.5' and 10.5' from each gutter.
6. Deflections should be recorded in a permanent form, preferably to an exaggerated scale.

In accordance with these criteria, test runs were planned as follows:

Test 1 - Runs 1 to 32, inclusive (item 1)

1. Center line of truck at 4.5' from north gutter  
2 runs at 3 mph  
2 runs at 20 mph
2. Center line of truck at 7.5' from north gutter  
2 runs at 3 mph  
2 runs at 35 mph
3. Center line of truck at 10.5' from north gutter  
2 runs at 3 mph  
2 runs at 20 mph  
2 runs at 40 mph  
2 runs at 50 mph

4. Center line of truck at 10.5' from south gutter  
2 runs at 3 mph  
2 runs at 20 mph  
2 runs at 40 mph  
2 runs at 50 mph (3)

5. Center line of truck at 7.5' from south gutter  
2 runs at 3 mph  
2 runs at 35 mph

6. Center line of truck at 4.5' from south gutter  
2 runs at 3 mph  
2 runs at 20 mph

Test 2 - runs 33 to 56 inclusive (item 2)

1. Center line of truck at 4.5' from north gutter  
2 runs at 3 mph  
2 runs at 40 mph

2. Center line of truck at 7.5' from north gutter  
2 runs at 3 mph  
2 runs at 40 mph

3. Center line of truck at 10.5' from north gutter  
2 runs at 3 mph  
2 runs at 40 mph

4. Center line of truck at 10.5' from south gutter  
2 runs at 3 mph  
2 runs at 40 mph

5. Center line of truck at 7.5' from south gutter  
2 runs at 3 mph  
2 runs at 40 mph

6. Center line of truck at 4.5' from south gutter  
2 runs at 3 mph  
2 runs at 40 mph

The method of measuring and recording deflections was similar to that used by the United States Bureau of Public

(3) Rough pavement west of the bridge made it impossible to obtain this speed safely. Actual speed is shown in the tabulation of deflections.

Roads for measuring bridge deflections and vibrations. Instruments used were SR-4 strain gages, with temperature compensation, three Honeywell 130-2C carrier amplifiers, and a 906 C Visicorder oscillograph, capable of recording six traces simultaneously.

The procedure was as follows:

An SR-4 strain gage was attached near the free end of an aluminum alloy cantilever beam, which, in turn, was rigidly attached at the other end to one of the bridge beams so that the cantilever was parallel to the length of the beam, approximately on its center line. The free end of the cantilever was tied down by a light cable to a weight on the ground below the bridge. The cable was tightened until the cantilever had an initial deflection of about two inches.

(See figure 1)

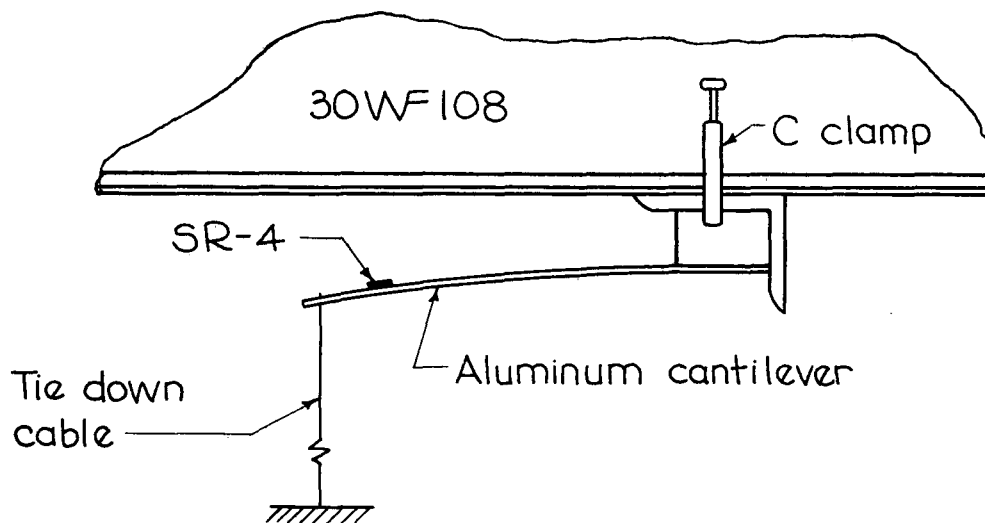

DEFLECTION GAGE

Figure 1

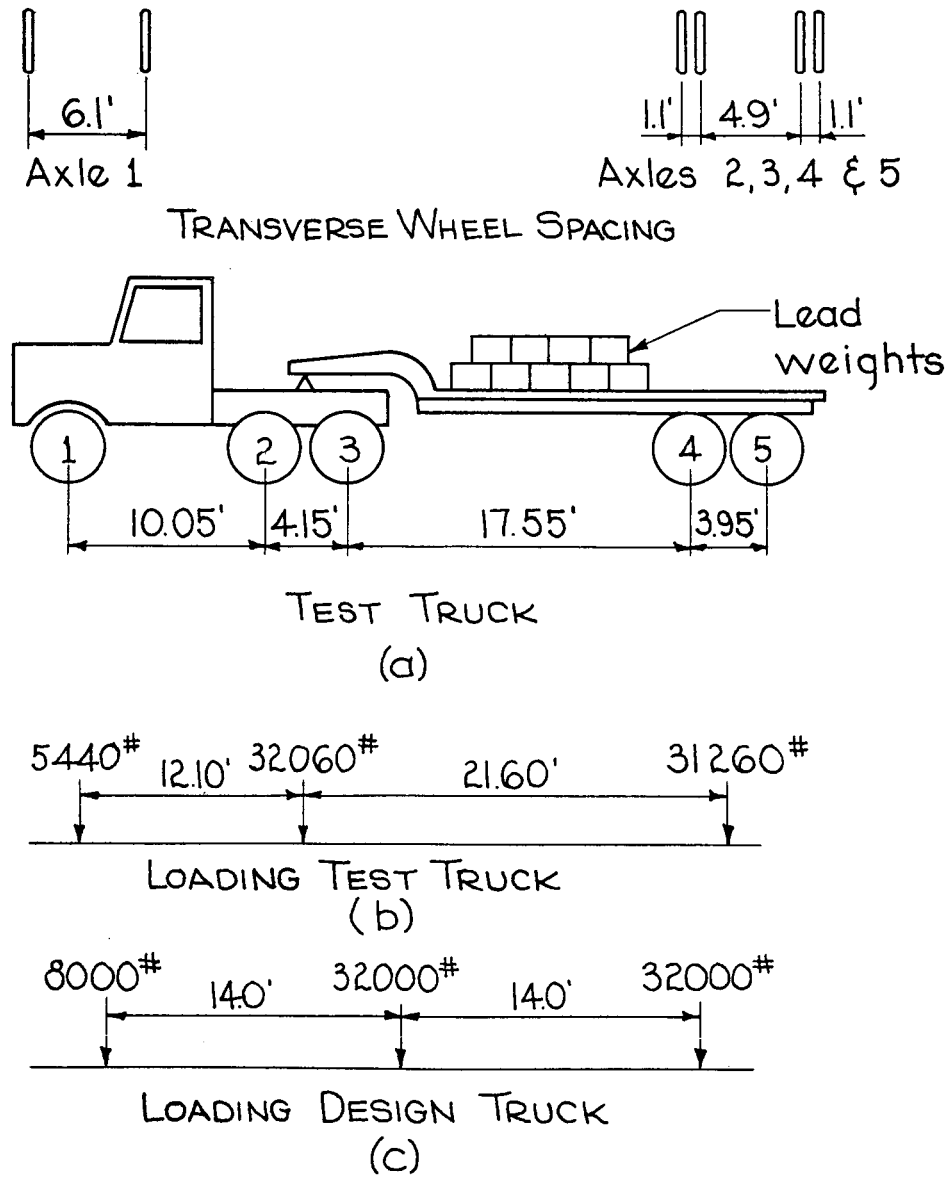

Figure 2

The SR-4 strain gage and its associated temperature compensating gage were connected to the oscillograph through the amplifiers by a four strand shielded cable.

The equipment was calibrated by a dial gage placed vertically at the end of the cantilever beam. A turnbuckle in the tie down cable was tightened until the dial gage showed  $\frac{1}{4}$ " deflection. The amplifier gain was then set so that the oscillograph showed 1" deflection. The gages were calibrated at the start and end of each days run.

As the bridge beam deflects under load, the cantilever deflection changes by an equal amount in the opposite direction, and the strain recorded by the SR-4 gage changes in proportion to the deflection. This change of strain is recorded on the oscillograph tape as four times the deflection, and this multiplication allows the deflection to be scaled to  $\pm 0.01$ ".

The truck used for loading the bridge was rented from Mr. Delbert Grosse of Council Bluffs, Iowa, who drove the truck during the tests. Figure 2(a) shows a sketch of the truck, figure 2(b) shows the loading diagram of the test truck used for calculating maximum moments, and figure 2(c) shows the loading diagram of the H20-S16-44 truck used for design. The test truck was loaded with lead weights, as shown, to produce the loading shown in figure 2(b).

Calculation of the maximum moments produced in the end span and in the center span by the test truck and the design truck showed that the design truck produced about 15% more moment (14.9% in the end span and 15.1% in the center span). Deflections produced by the test truck were therefore increased 15% to approximate the deflections produced by the design truck.

Shortly before the field tests began, Mr. Derwin Merrill, a summer employee of the Materials Department, joined Mr. Moothart and Mr. Sharpnack. Mr. Merrill was in charge of the oscillograph during the tests, and afterward measured the deflections and calculated and recorded the data. Mr. Merrill is now a member of the faculty of the Engineering Mechanics division of Iowa State University, Ames, Iowa.

In order to guide the truck in the test runs, lines of tape were placed longitudinally on the bridge floor to locate the center line of the truck at 4.5', 7.5' and 10.5' from each gutter (see figure 3) and a boom was attached to the front of the truck with a tell tale hanging down located so that it was visible to the driver. By keeping this tell tale above the appropriate line of tape, the driver was able to follow the proper path.

To check the actual location of the truck, four lines of tape were placed on the bridge floor normal to the center line of roadway, as shown in figure 3. Immediately before each run, shaving lather was extruded from a pressure can on each

of these transverse tapes. The truck left clear tracks in the shaving lather, and measurement from the gutter line to these tracks located the trucks path accurately.

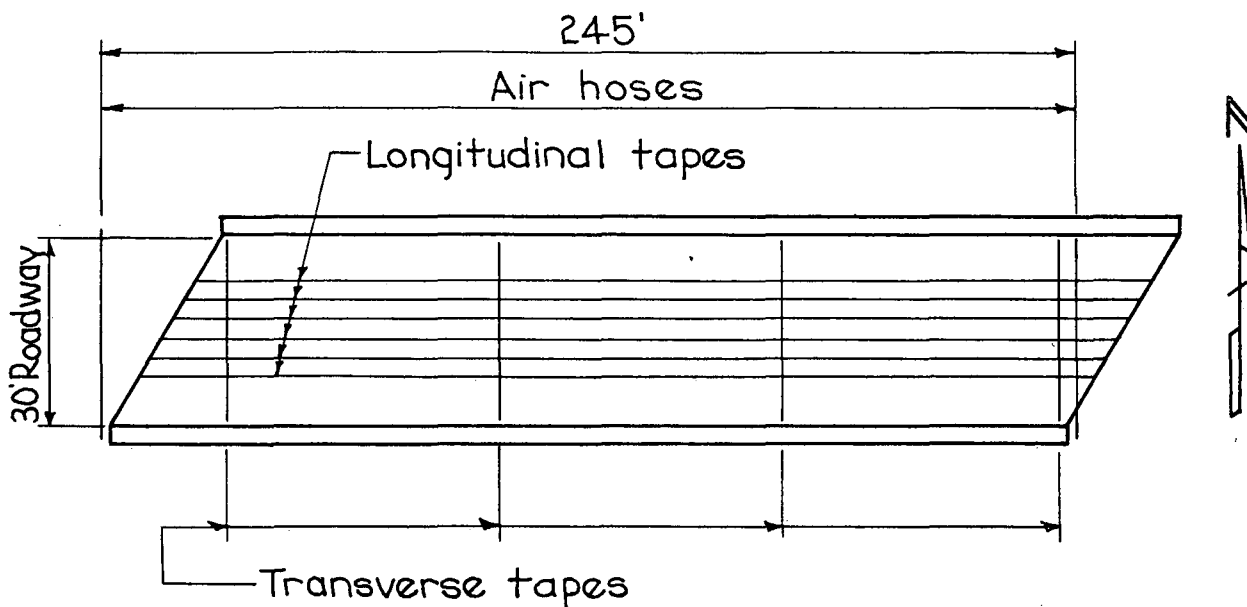

Figure 3

To determine the speed of the truck, air hoses, actuating pressure switches, were placed near the ends of the bridge, 245' apart, as shown in figure 3. When the truck passed over these tapes, the pressure switches produced blips on the oscillograph tapes. The scaled distance, in inches, between these blips, divided by the known speed of the tape in inches per second gives the time in seconds of the truck's passage. 245', divided by the time, gives the truck's speed in feet per second, which is translated into miles per hour.

For test 1, SR-4 gages were placed on the two north beams, 29' from the center line of abutment bearings in the end spans,



and midway between pier bearings in the center span. Figure 4 is a structural layout of the beams, showing the location of these gages.

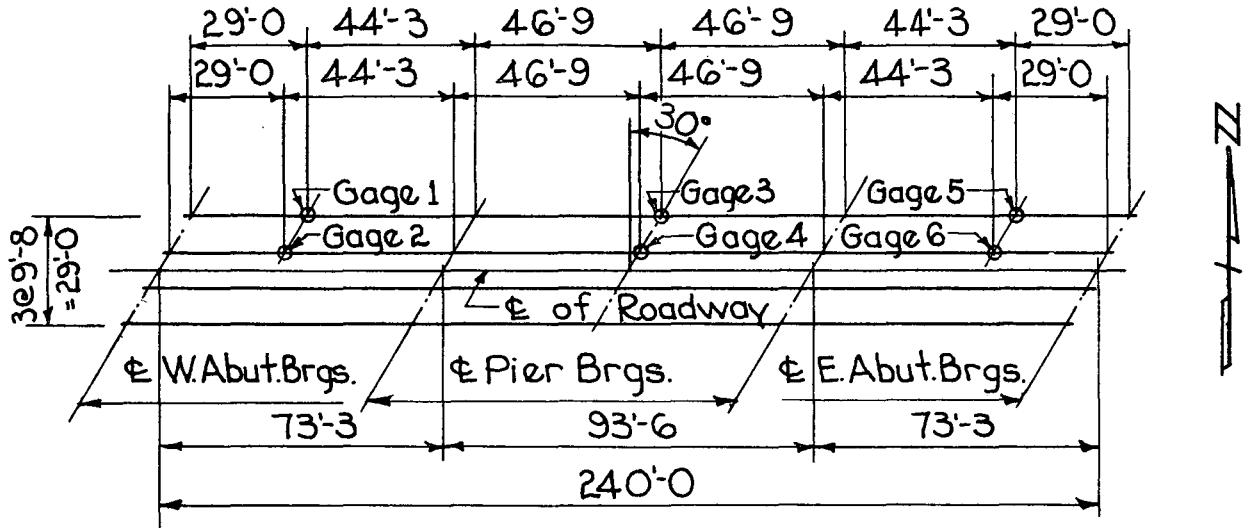

Figure 4

Test 2. was made to check the lateral symmetry of the bridge. For this test, gages 5 and 6 were placed on the south interior and exterior beams, respectively, midway between pier bearings in the center span. Figure 5 shows a structural layout of the beams in the center span, locating these gages.

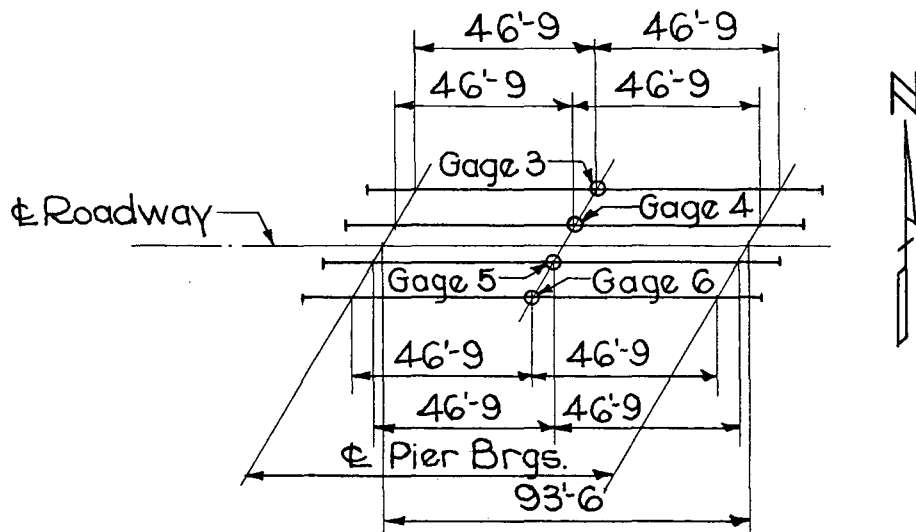

Figure 5

The tests were run on the 18th, 19th, and 20th of June, 1963. A total of 49 runs were made for Test 1, and 25 for Test 2. 17 runs were eliminated from Test 1, and 1 from Test 2, because of misplacement of truck, wrong speed, or mechanical failure. The deflections, recorded on oscillograph tape, were permanized by chemical treatment, and are retained in the files of the Iowa State Highway Commission as a permanent record.

Tables 1 and 2 show the results of Tests 1 and 2 respectively. For each run, the maximum deflection for each gage, including vibration and impact, are recorded to the nearest even hundredth of an inch. Table 2 indicates reasonably symmetrical behavior.

TABLE 1

TEST 1 - RUNS 1-32 INCLUSIVE

Run No.	Location of Truck & Direction	Speed mph	Deflection in Inches at Gage No.					
			1	2	3	4	5	6
1	4.5' from	3.03	0.35	0.27	0.68	0.47	0.42	0.33
3	North gutter	2.78	0.38	0.28	0.68	0.47	0.38	0.31
5	East to West	22.4	0.41	0.27	0.67	0.46	0.44	0.33
7		20.4	0.40	0.28	0.67	0.46	0.45	0.32
9	7.5' from	2.60	0.32	0.28	0.53	0.43	0.32	0.31
11	North gutter	3.06	0.30	0.28	0.57	0.47	0.35	0.32
13	East to West	35.0	0.39	0.35	0.58	0.48	0.35	0.32
15		36.7	0.39	0.36	0.59	0.49	0.33	0.34
17	10.5' from	2.79	0.23	0.29	0.42	0.42	0.26	0.30
19	North gutter	5.71	0.25	0.30	0.46	0.47	0.26	0.32
21	East to West	20.1	0.23	0.30	0.44	0.46	0.26	0.32
23		20.6	0.23	0.26	0.43	0.44	0.26	0.31
25		41.6	0.29	0.31	0.48	0.47	0.29	0.37
27		41.5	0.25	0.32	0.49	0.47	0.26	0.31
29		53.9	0.24	0.29	0.49	0.51	0.28	0.33
31		54.7	0.25	0.30	0.50	0.50	0.26	0.32
32	10.5' from	43.4	0.09	0.20	0.20	0.36	0.09	0.21
30	South gutter	43.7	0.09	0.20	0.21	0.35	0.12	0.21
28	West to East	39.9	0.08	0.20	0.24	0.37	0.11	0.23
26		41.0	0.09	0.19	0.22	0.35	0.10	0.22
24		21.7	0.09	0.20	0.19	0.32	0.09	0.21
22		20.2	0.08	0.20	0.18	0.31	0.09	0.21
20		3.90	0.08	0.19	0.17	0.32	0.09	0.20
18		2.65	0.09	0.20	0.17	0.30	0.08	0.18
16	7.5' from	35.5	0.07	0.18	0.18	0.32	0.10	0.20
14	South gutter	35.9	0.07	0.16	0.17	0.31	0.10	0.19
12	West to East	2.70	0.04	0.16	0.08	0.25	0.06	0.14
10		2.61	0.05	0.16	0.08	0.24	0.06	0.14
8	4.5' from	20.8	0.02	0.12	0.04	0.22	0.02	0.11
6	South gutter	19.9	0.02	0.12	0.05	0.22	0.03	0.12
4	West to East	2.89	0.02	0.12	0.03	0.20	0.02	0.11
2		2.81	0.01	0.12	0.02	0.18	0.02	0.12

TABLE 2

TEST 2 - RUNS 33-56 INCLUSIVE

Run No.	Location of Truck & Direction	Speed mph	Deflection in Inches at Gage No.			
			3	4	5	6
49	4.5' from	2.96	0.66	0.43	0.19	0.01
51	North gutter	3.21	0.67	0.44	0.19	0.02
53	East to West	38.4	0.72	0.49	0.24	0.10
55		40.7	0.71	0.48	0.23	0.07
41	7.5' from	2.70	0.61	0.44	0.25	0.12
43	North gutter	2.72	0.55	0.45	0.23	0.06
45	East to West	39.6	0.57	0.47	0.25	0.09
47		38.0	0.57	0.46	0.29	0.09
33	10.5' from	2.79	0.44	0.43	0.32	0.18
35	North gutter	2.68	0.44	0.43	0.32	0.20
37	East to West	35.7	0.49	0.49	0.38	0.24
39		35.2	0.50	0.50	0.37	0.24
40	10.5' from	35.3	0.21	0.35	0.47	0.45
38	South gutter	35.0	0.21	0.34	0.49	0.45
36	West to East	2.87	0.17	0.31	0.44	0.42
34		2.75	0.18	0.30	0.42	0.44
48	7.5' from	38.9	0.11	0.25	0.47	0.59
46	South gutter	39.6	0.13	0.27	0.48	0.59
44	West to East	2.90	0.09	0.23	0.42	0.52
42		2.66	0.09	0.24	0.44	0.45
56	4.5' from	40.6	0.08	0.23	0.48	0.68
54	South gutter	40.6	0.09	0.24	0.48	0.67
52	West to East	3.27	0.03	0.19	0.43	0.64
50		2.96	0.03	0.20	0.44	0.62

The following procedure was used to calculate the maximum deflection under the design load with two lanes loaded:

1. For each gage, the absolute maximum deflection for any run of test 1, or test 2, if applicable, was chosen.
2. To this was added the maximum deflection, at that gage, caused by any run on the other half of the bridge.
3. The sum of these deflections was multiplied by 1.15 to approximate the deflection caused by the design load.
4. This deflection was expressed as a fraction of the span, for comparison with the AASHO allowable deflection.

The calculations follow:

Gage 1

Run 5	0.41"	4.5' from north gutter
Run 32	<u>0.09"</u>	10.5' from south gutter
	0.50"	

For design load H20-S16-44

$$(0.50") (1.15) = 0.58"$$

$$\frac{0.58}{(73.25)(12)} = \frac{1}{1520}$$

approx.

Gage 2

Run 15	0.36"	7.5' from north gutter
Run 32	<u>0.20"</u>	10.5' from south gutter
	0.56"	

For design load H20-S16-44

$$(0.56") (1.15) = 0.64"$$

$$\frac{0.64}{(73.25)(12)} = \frac{1}{1370}$$

approx.

Gage 3

Run 53	0.72"	4.5' from north gutter
Run 28	<u>0.24"</u>	10.5' from south gutter
	0.96"	

For design load H20-S16-44

$$(0.96") (1.15) = 1.10"$$

$$\frac{1.10}{(93.5)(12)} = \frac{1}{1020}$$

approx.

Gage 4

Run 29	0.51"	10.5'	from north gutter
Run 28	<u>0.37"</u>	10.5'	from south gutter
	0.88"		

For design load H20-S16-44

$$(0.88") (1.15) = 1.01"$$

$$\frac{1.01}{(93.5)(12)} = \frac{1}{1110}$$

approx.

Gage 5 (Test 1)

Run 7	0.45"	4.5'	from north gutter
Run 30	<u>0.12"</u>	10.5'	from south gutter
	0.57"		

For design load H20-S16-44

$$(0.57") (1.15) = 0.66"$$

$$\frac{0.66}{(73.25)(12)} = \frac{1}{1330}$$

approx.

Gage 6 (Test 1)

Run 25	0.37"	10.5'	from north gutter
Run 28	<u>0.23"</u>	10.5'	from south gutter
	0.60"		

For design load H20-S16-44

$$(0.60") (1.15) = 0.69"$$

$$\frac{0.69}{(73.25)(12)} = \frac{1}{1270}$$

approx.

All deflections are well within the allowable limits of the AASHO specifications. The deflections show some inconsistencies, as follows:

1. Deflections in the east end span (gages 5 and 6) are greater than those in the west end span. (gages 1 and 2).
2. In the end spans, the deflections of the interior beam is greater than that of the exterior beam; in the center span the deflection of the exterior beam is greater.

These inconsistencies could probably be explained, but we believe the data are insufficient to permit a definite conclusion.

We believe, however, that the deflections obtained approximate quite closely the maximum deflections under the design load, and that prestressed steel beam bridges perform satisfactorily in service.

Although the Silver Creek bridge showed a saving of \$2500 over a welded girder bridge of the same dimensions and skew angle, we believe that the economic advantage of prestressed steel construction would be greater for a shorter span, where the competing design would be fabricated from rolled beams. It is possible that a continuous prestressed steel bridge would be competitive in price with prestressed concrete for grade separations on or over an Interstate Highway. We recommend, therefore, that other prestressed steel bridges be designed and built in order to test the economical span, and to establish their cost under normal conditions.



Photo 1: General view of the Silver Creek Bridge.

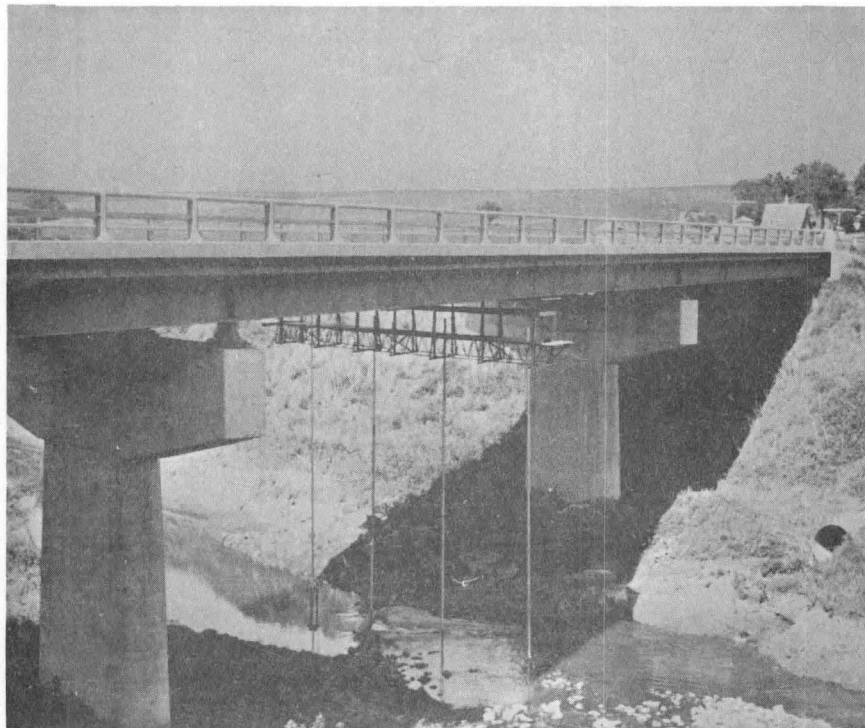

Photo 2: Bridge, showing falsework erected for installing deflection gages.



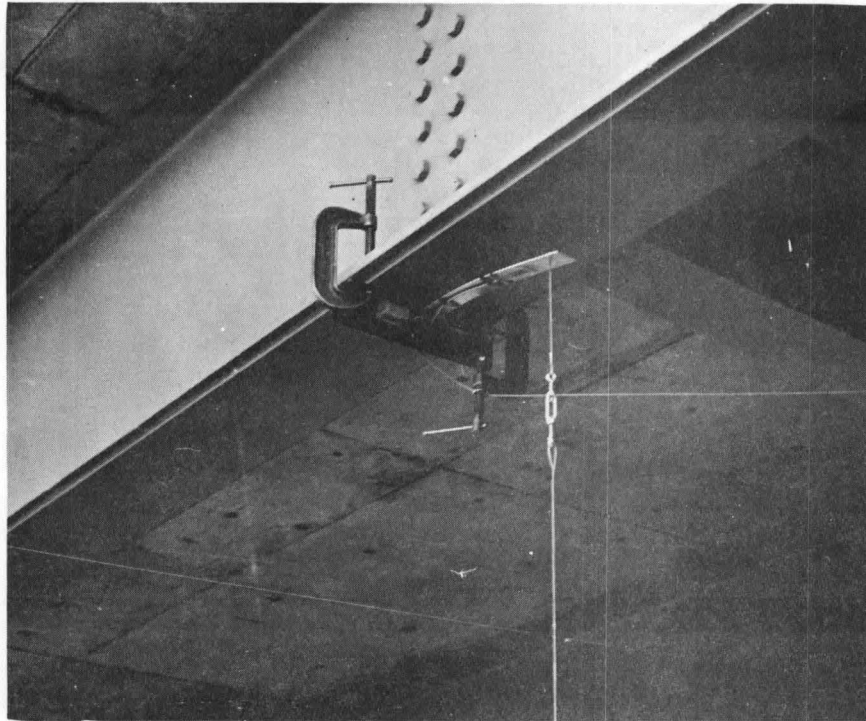

Photo 3: Cantilever type deflection gage attached to bridge beam.

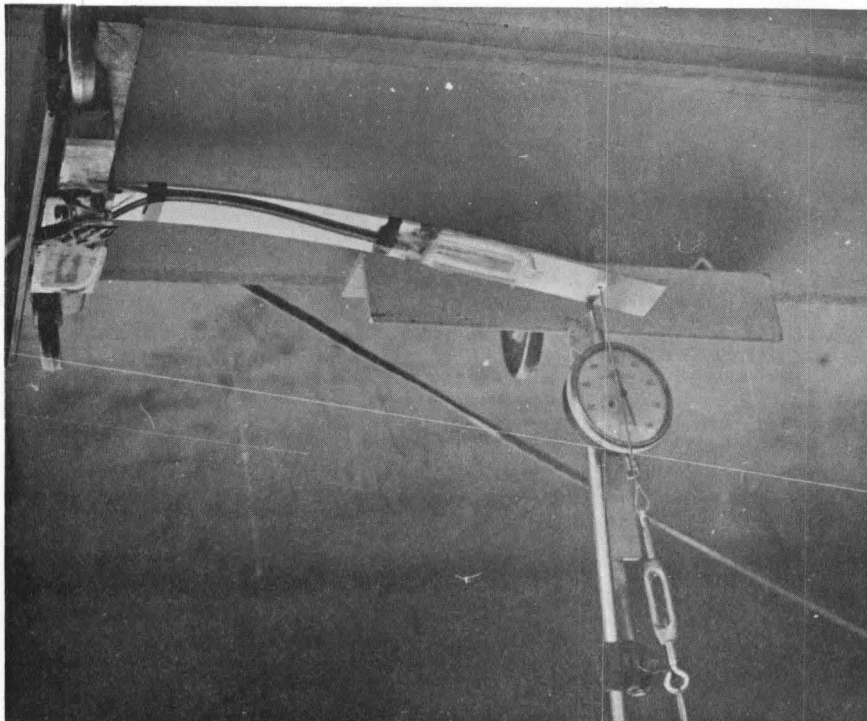

Photo 4: Mechanical calibration of deflection gage.



Photo 5: Test truck, showing tell tale guide for driver.

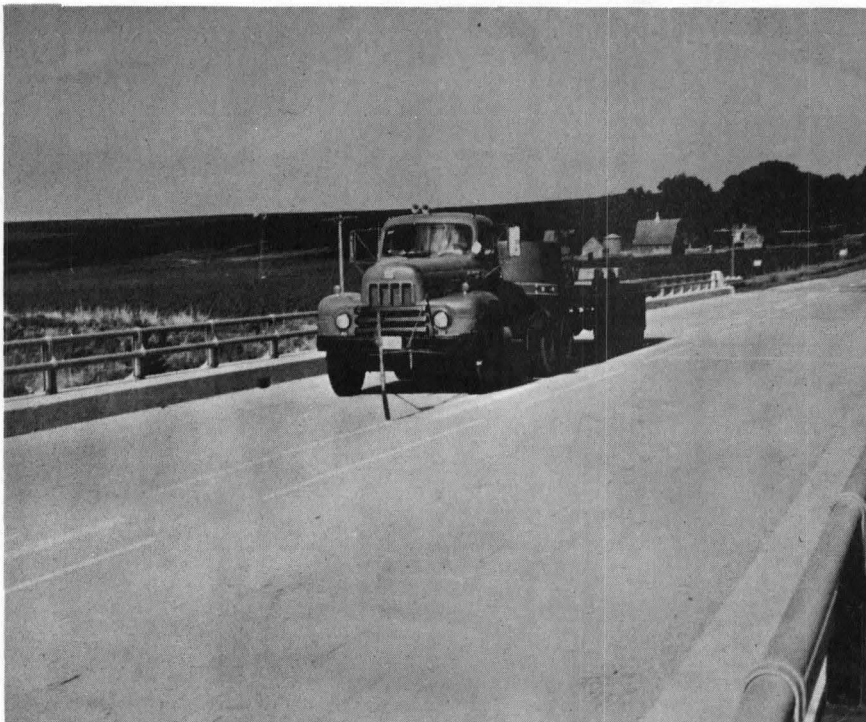

Photo 6: Truck on bridge during test run.