

Investigation of the Iowa Department of Human Services' Oversight of a Child Care Center



Ruth H. Cooperrider
Ombudsman

September 11, 2013

Contributors

Investigator

Jeff Burnham, Assistant Ombudsman

Advisory Assistant

Barbara Van Allen, Assistant Ombudsman
(Child Welfare Specialist)

Legal Counsel

Andy Teas

Ombudsman

Ruth Cooperrider

TABLE OF CONTENTS

PREFACE	iv
EXECUTIVE SUMMARY	1
ONE FAMILY’S NIGHTMARE	5
OVERVIEW OF OMBUDSMAN’S INVESTIGATION	7
COMPLAINTS	7
INVESTIGATION	7
ISSUES INVESTIGATED	8
CHALLENGE TO INFORMATION ACCESS	9
DHS’S AUTHORITY TO REGULATE CHILD CARE CENTERS	10
CHRONOLOGY	13
ISSUE #1: <i>Whether DHS failed to provide timely notice to parents about the seven founded abuse reports regarding incidents that occurred at CDC on or about April 15, 2010, contrary to Iowa Code section 237A.5(2)(k)</i>	18
RELEVANT STATUTE.....	18
FINDINGS OF FACT.....	18
CONCLUSION.....	19
RECOMMENDATION	19
ISSUE #2: <i>Whether DHS’s June 4, 2010, letter to parents failed to identify the types of abuse, contrary to Iowa Code section 237A.5(2)(k)</i>	20
ISSUE #3: <i>Whether DHS has still not provided written notice to CDC parents regarding the types of abuse incidents that occurred at CDC on or about April 15, 2010, contrary to Iowa Code section 237A.5(2)(k)</i>	20
RELEVANT STATUTE.....	20
FINDINGS OF FACT.....	20
CONCLUSION	22
RECOMMENDATION	22
ISSUE #4: <i>Whether DHS took appropriate and timely follow-up action consistent with law, rules, policies, and practices in considering or reviewing CDC’s license status after reducing the license to provisional status effective April 1, 2010</i>	23
RELEVANT STATUTES, RULES, AND POLICY	23
Suspended and revoked licenses.....	23

Provisional licenses	24
Minimum standards	24
FINDINGS OF FACT	25
ANALYSIS AND CONCLUSIONS	30
<i>Whether the DHS’s decision not to suspend or revoke CDC’s child care license was reasonable</i>	<i>30</i>
CONCLUSION.....	33
RECOMMENDATIONS	33
<i>Whether the DHS took reasonable follow-up actions in determining whether CDC actually corrected its deficiencies</i>	<i>33</i>
DHS field staff made no visits to the CDC over a critical eight-month span.....	34
DHS did not timely determine the adequacy of CDC’s Corrective Action Plan.....	34
“It wasn’t one of our shining moments”	37
CONCLUSION.....	38
ISSUE #5: <i>Whether DHS’s failure to notify parents of all CDC children of the provisional license action was unreasonable, even though in accordance with law</i>	39
RELEVANT STATUTE	39
FINDINGS OF FACT	39
ANALYSIS	40
CONCLUSION	41
RECOMMENDATIONS	41
ISSUE #6: <i>Whether DHS’s actions in editing and/or redacting the original licensing inspection report about the June 3, 2010, incident were inconsistent with policy or based upon improper motivation</i>	42
RELEVANT POLICY	42
FINDINGS OF FACT	43
Different versions of Complaint Report #4	43
Different versions of Complaint Report #5	44
ANALYSIS	46
CONCLUSION	46
RECOMMENDATION	46

ISSUE #7: Whether DHS provided consumers with regular informational updates on the Internet, as required by Iowa Code section 237A.25(3)(b), following the founded abuse reports involving CDC	47
RELEVANT STATUTE	47
FINDINGS OF FACT	48
CONCLUSION	50
RECOMMENDATION	50
ISSUE #8: Whether DHS took appropriate and timely follow-up action consistent with law, rules, policies, and practices regarding CDC’s “Quality Rating” under the system authorized by Iowa Code section 237A.30 following the founded abuse reports involving CDC	51
RELEVANT STATUTE AND ADMINISTRATIVE RULES	51
ADDITIONAL CLARIFICATIONS ON DHS’S WEBSITE	52
FINDINGS OF FACT	53
ANALYSIS	54
CONCLUSION	55
RECOMMENDATIONS	55
PROVISIONAL LICENSE AND DUE PROCESS REQUIREMENTS	57
RECOMMENDATION	58
DEPARTMENT OF HUMAN SERVICES’ REPLY	59
ADDITIONAL INFORMATION REQUESTED BY THE OMBUDSMAN	68
DEPARTMENT OF HUMAN SERVICES’ RESPONSE TO REQUEST FOR ADDITIONAL INFORMATION	71
LETTER FROM CHILDREN & FAMILIES OF IOWA	81
OMBUDSMAN’S COMMENT	83

PREFACE

The Iowa Office of Ombudsman (Ombudsman) is an independent and impartial agency in the legislative branch of Iowa state government which investigates complaints against most Iowa state and local government agencies. Its powers and duties are defined in Iowa Code chapter 2C.

The Ombudsman can investigate to determine whether agency action is unlawful, contrary to policy, unreasonable, unfair, oppressive, or otherwise objectionable. The Ombudsman may make recommendations to the agency and other appropriate officials to correct a problem or to improve government policies, practices, or procedures. If the Ombudsman determines a public official has acted in a manner warranting criminal or disciplinary proceedings, the Ombudsman may refer the matter to the appropriate authorities.

If the Ombudsman decides to publish a report of the investigative findings, conclusions, and recommendations, and the report is critical of the agency, the agency is given an opportunity to reply to the report, and the unedited reply is attached to the report.

EXECUTIVE SUMMARY

Over a three-month period in 2010, our office received three complaints alleging the Department of Human Services (DHS) was lax in its oversight of a licensed child care center. It was alleged that the DHS did not sanction the child care center in any meaningful way after finding several violations associated with children engaging in sexual behavior with each other at the center. This involved the Child Development Center (CDC) in Des Moines, which is owned and operated by Children and Families of Iowa (CFI).

The DHS is authorized by chapter 237A of the Code of Iowa to regulate the licensing of child care centers. This includes authority to set minimum standards for licensed child care centers and to enforce these standards. If a center violates a provision of chapter 237A, the DHS may—after providing notice and an opportunity for a hearing—suspend or revoke the center’s license under section 237A.8. A violation can also result in a center’s license being reduced to provisional status.

After conducting a preliminary review, notice of our investigation was sent to then-DHS Director Charles Krogmeier on November 23, 2010. Following is a summary of our investigative findings:

1. Over a three-month period—March 18, 2010, to June 17, 2010—the DHS received five complaints about the CDC.

One complaint involved a three-year old boy who had been caught several times with his hands in other children’s pants, or with their hands touching his penis. A DHS employee who investigated the complaint concluded that CDC administrators had ignored reports from staff about the children’s sexual behaviors. Based on her findings, the DHS investigator cited CDC for a number of violations and required CDC to submit a written “plan of correction” within one month. She also reduced CDC’s license to provisional status.

2. Approximately two weeks following the DHS report, the DHS received a new complaint about an incident in which several five-year-old boys reportedly engaged in sexual behavior while not being directly supervised at the CDC. Based on interviews of the four boys, the DHS investigator’s report included references to penises being touched, shaken, and sucked. While two teachers had been assigned to the room, one teacher was focused on treating a child who had bumped and cut his head on the playground. The other teacher had left the room to attend to other matters. Neither teacher had been made aware by CDC administrators of the previous sexual behaviors involving children in other classrooms.
3. Based on her review of that incident, the DHS investigator recommended that the DHS should begin the process of revoking CDC’s license if the incident resulted in any founded child abuse reports against CDC staff. While the issue of whether to suspend or revoke CDC’s license was the subject of internal discussions among DHS management, the DHS’s Adult, Children and Family Services Division Administrator decided not to pursue either option. CDC’s license was continued on provisional status, with the DHS taking no further enforcement action.

4. During that same time, the supervisor of the DHS investigator rewrote her report regarding the second incident because he was concerned it contained too many references to the word “penis.” We found the DHS’s actions in rewriting the complaint investigation report were inconsistent with policy in existence at the time.
5. We are willing to concede that the DHS should only use suspension or revocation in the most dangerous of situations because closing a center can be a significant hardship for many of the effected families. As a result, we did not conclude the DHS’s decision not to pursue a license suspension or revocation was clearly unreasonable. However, the decision not to pursue a license suspension or revocation made it absolutely critical that the DHS closely monitor the CDC, primarily to ensure that the deficiencies surrounding children’s sexual behaviors were corrected in a timely manner.
6. On June 18, 2010, the DHS received CDC’s written response to the required actions that had been imposed by the DHS in the initial investigation. In a complaint investigation report submitted several days later, the DHS investigator documented that CDC’s written response did not address a requirement to remove “visual obstructions” from the CDC’s classrooms. The DHS investigator retired soon thereafter; her written statement was the only record we could find of a DHS employee determining, in 2010, whether any portions of CDC’s written response were acceptable.
7. During our investigation, we asked the DHS for clarification regarding CDC’s written responses to four of the DHS’s required actions. The DHS later acknowledged that in order to answer our inquiries, department staff had to request additional information from CDC. This occurred in January 2012—about 18 months after the DHS had received CDC’s written responses. We found no indication that DHS administrators were even aware, before our investigation, that any of CDC’s written responses had been inadequate.
8. DHS staff made no return visits to the CDC over a crucial eight month period (July 2010-March 2011). Incredibly, DHS administrators apparently were not even aware of this failure until it was brought to light by our inquiries.

Based on our findings, we conclude the DHS did not take reasonable follow-up actions in determining whether CDC actually corrected its deficiencies.

Subsequent monitoring visits by the DHS in 2011 and 2012 found the CDC to be in “substantial compliance” with the licensing standards. Fortunately, no further sexual incidents were reported at CDC after the 2010 episodes—the sexual behaviors apparently stopped—but this was in spite of the DHS dropping the ball. “It would be hard for me to say that we were totally on top of it,” acknowledged Division Administrator Wendy Rickman, “when we did not have specific visits there in a fairly long amount of time.” She added, “It wasn’t one of our shining moments.”

Rickman said her division held a “post audit” of the CDC case to discuss what didn’t go well and how to do a better job in the future. “I think we’re doing in general a much better job across the board with facilities, with child care centers, Rickman said. “You would see a completely different response today than you saw back then.”

Through our investigation we also determined:

1. The DHS failed to provide timely notice to parents about the seven founded abuse reports that occurred at CDC in spring 2010, contrary to Iowa Code section 237A.5(2)(k).
2. The DHS's June 4, 2010, letter to parents failed to identify the types of abuse, contrary to section 237A.5(2)(k)
3. The DHS has still not provided accurate information to CDC parents regarding the types of abuse incidents that occurred at CDC in spring 2010, contrary to section 237A.5(2)(k).
4. It was unreasonable for the DHS not to mention the provisional license action in at least one of the letters sent to families in 2010.
5. The DHS has not been providing child care consumers with regular informational updates on the Internet, contrary to section 237A.25(3)(b), concerning CDC and other licensed child care centers.
6. The DHS did not take appropriate and timely follow-up action consistent with law regarding CDC's "Quality Rating" under the system authorized by section 237A.30.

As a result of our investigation, the following 13 recommendations are presented to the DHS:

1. The DHS should amend its administrative rules and Employees' Manual to reflect the new procedures described above.
2. The DHS should consider whether it would be appropriate to provide a follow-up communication to then-CDC parents to clarify the types of abuse incidents that occurred at CDC in spring 2010.
3. The DHS should review its administrative rules and its Employees' Manual regarding revocations, suspensions, and provisional licenses with the goal of providing clearer guidance regarding the types of circumstances where each of these options is warranted.
4. The DHS should amend Iowa Administrative Code rule 441—109.10(10) in a way that makes it clear that incidents in which a child engages in sexual behavior that is clearly age-inappropriate must be reported immediately to the parent.
5. The DHS should amend rule 441—109.4(2) to require centers to develop and implement written policies ensuring staff training and development for reporting child abuse and age-inappropriate sexual behavior.
6. The DHS should review the "Child Care Centers" section of its Employees' Manual (Chapter E of Title 12; last revised in 2005) and make any necessary modifications, as appropriate, so that the language in Chapter E is consistent with the department's current practices and procedures. This investigation has revealed several inconsistencies between language in Chapter E and DHS's actual practice. Here are two such examples:
 - *Chapter E says:* The licensing supervisor must give approval if a complaint investigation causes a child care consultant to recommend a negative licensing action, such as suspension or revocation (page 12). Similar language also appears on page 1
 - *Current practice:* The manager of the Centralized Service area must also give approval.

- *Chapter E says:* Letters notifying families about a founded child abuse report involving a center employee are signed by the child care consultant.

Current practice: Such letters are signed by the division administrator.

7. Legislative proposal: Iowa Code chapter 237A should be amended to require the DHS to provide notice to parents whose children attend a facility in which the license is placed on provisional status. This could be accomplished by modifying section 237A.8 as follows:

237A.8 Violations — actions against license or registration.

The administrator, after notice and opportunity for an evidentiary hearing before the department of inspections and appeals, may suspend or revoke a license or certificate of registration issued under this chapter or may reduce a license to a provisional license if the person to whom a license or certificate is issued violates a provision of this chapter or if the person makes false reports regarding the operation of the child care facility to the administrator or a designee of the administrator. The administrator shall notify the parent, guardian, or legal custodian of each child for whom the person provides child care at the time of action to suspend or revoke a license or certificate of registration, or to reduce a license to provisional status.

8. The DHS should amend Iowa Administrative Code rule 441—109.4(3)(a) as follows:

109.4(3) Required postings.

a. Postings are required for the certificate of license, notice of exposure of children to a communicable disease, and notice of actions to deny, suspend, or revoke the center’s license, as well as notice of actions to reduce the center’s license to provisional status, and shall be conspicuously placed at the main entrance to the center. If the center is located in a building used for additional purposes and shares the main entrance to the building, the required postings shall be conspicuously placed in the center in an area that is frequented daily by parents or the public.

9. The DHS should review and clarify or modify its policy regarding the process and the circumstances under which licensing complaint reports may be revised or any portions may be redacted and by whom, including who has final review and approval of such reports, and when such reports are placed in the public files or sent to child care centers.
10. The DHS should provide our office with confirmation when it has fully developed and implemented the website improvements to comply with Iowa Code section 237A.25(3).
11. The DHS should remove the “point in time” assessment paradigm for the QRS program and replace it with a system which allows for adjustments to be made contemporaneously with significant instances of non-compliance. For example, the DHS could adjust the QRS program so that a center, in addition to earning points in various categories, can also lose points in various categories.
12. Until or unless Recommendation 11 is implemented, the DHS should take immediate action to ensure that families who receive QRS referrals are advised that the ratings represent a “point in time” assessment and may not reflect instances of non-compliance with law and rules that have occurred since the center’s current rating was determined.
13. The DHS should amend its administrative rules and practices to provide notice and opportunity for a hearing when it takes action to reduce a license to a provisional license under Iowa Code section 237A.8.

ONE FAMILY'S NIGHTMARE

The nightmare began when Lisa¹ noticed her son's child care center looked almost deserted when she dropped him off. Lisa realized she had not seen the center's two administrators in weeks. Other employees also seemed to be missing.

One morning, Lisa tried to get answers. "What's going on?" she asked an employee.

"There's an investigation," the employee responded.

"What kind?" Lisa asked. The employee confirmed it involved the Department of Human Services (DHS) but would not reveal anything further.

Lisa contacted the DHS office which oversees licensed child care centers in her area. She was told that an investigation had just been completed in response to a complaint about the center. Lisa went to the DHS child care licensing office to get a copy of the investigator's written report.

Although the DHS report involved children in another classroom, Lisa was alarmed by what she read. According to the DHS report, a three-year old boy had been caught several times with his hands in other children's pants, or with their hands touching his penis. "When staff brought it to the supervisor's attention, they were told to let it go; that it was no big deal; that they were just kids being kids," the DHS report said. "But the boy's language seems more like an adult. The boy has said, 'I'm going to stick my dick in your ass.'"

According to the report, the DHS investigator concluded that center administrators had ignored reports from staff about the children's "blatant inappropriate" sexual behaviors. "All of the staff expressed frustration regarding what they perceived as the administrators' dismissive attitude and lack of support in dealing with children's behaviors," the report said.

The DHS investigator's report also discussed the "perception that at least two staff have been terminated for reporting their concerns to DHS." While stating that "retaliation is hard to prove," the report said, "At least two staff stated that they were concerned that they would be retaliated against for speaking with the DHS investigators."

The DHS investigator's report concluded:

Based upon the numerous licensing violations cited, the status of the (*child care center*) license is being changed from full to provisional. The center will need to correct those cited areas, and provide the consultant with a written plan of correction that includes a detailed description of each remedy.

Because the incidents had occurred in another classroom, Lisa did not feel a need to immediately remove her son from the center. She decided she would remove him following his last day of the center's school year, which was only two weeks away.

Lisa would soon regret not removing her son immediately.

The next week—just days before the last day of the center's school year—Lisa received a phone call one afternoon around 4 p.m. The call was from her son's teacher, who told Lisa that her son

¹ Not her real name.

was going to be identified as a victim of child abuse in a report to the DHS. When Lisa got to the center, the teacher gave her a typed note which said her son was among four boys who were found together “laying on the floor with their pants down.”

According to the typed note, the teachers asked the boys what happened and learned they had engaged in extremely inappropriate sexual behavior. From the typed note, Lisa learned one boy pulled her son’s pants down and shook his penis while playing “girlfriend and boyfriend.” The same boy was encouraged by another to “hump” Lisa’s son.

The new incident was reported to the DHS licensing consultant. Lisa later obtained a copy of the DHS’s written investigative report. Based on interviews of the four boys, DHS’s report included references to penises being touched, shaken, and sucked.

DHS’s report identified several contributing factors to the incident:

1. Neither teacher had been made aware by center administrators of the previous sexualized behaviors involving children in other classrooms. “They had not received any training on prevention, nor have they been told what to do if such an incident occurred,” the report stated.
2. The boys were playing in an area that was almost entirely enclosed “creating an effective obstruction to visual supervision.”
3. While two teachers were assigned to the room, one teacher was focused on treating a child who had bumped and cut his head on the playground. The other teacher had left the room to attend to other matters.
4. The teachers were aware two of the boys engaged in more mature play when they were together and usually tried to keep them separated. But “on this occasion staff seemed to have abandoned any situational awareness” and allowed the two boys to be together, the DHS’s report stated.

Because the center’s license had already been reduced to provisional status, Lisa expected the DHS would take stronger enforcement action in light of the incident involving her son. But the DHS took no further enforcement actions against the center.

Around the same time, Lisa received notice that, based on DHS’s assessment, her son was the victim in two founded cases of child abuse that would be placed on DHS’s Central Abuse Registry. Both founded reports involved denial of critical care (failure to provide proper supervision) regarding the incident with the three other boys.

Based on other letters from the DHS, Lisa learned there were a total of 15 founded child abuse reports involving center staff. Eight of those reports involved the incident with the four boys. The other seven reports involved incidents that had occurred a few months before at the center.

Lisa eventually filed a complaint with the Ombudsman about DHS’s regulatory response to these matters. Lisa explained her complaint in an email which stated:

Had the items within [*DHS’s first*] licensing report been addressed at the most minimal level, my son would not have been listed as a victim of abuse.... He has since been exhibiting behaviors that suggest he has been impacted in a way that may last for years.

OVERVIEW OF OMBUDSMAN'S INVESTIGATION

COMPLAINTS

Over a three-month period in 2010, our office received three complaints alleging the DHS was lax in its oversight of a licensed child care center.² The DHS found several violations associated with children engaging in sexual behavior with each other at the center. It was alleged that the DHS did not sanction the child care center in any meaningful way.

This involved the Child Development Center (CDC) in Des Moines, which is owned and operated by Children and Families of Iowa (CFI). CFI holds dozens of contracts with government agencies in Iowa, including a number of contracts with the DHS. The DHS has made frequent referrals of children with protective and special needs to the CDC, which has an enrollment of 125 children and primarily serves children and families in crisis, according to DHS licensing records.

Citing the ongoing relationship between the DHS and CFI, the complainants believed the DHS was more interested in protecting CFI's interests than in protecting the children who attended CFI's child care center. The first complaint to our office was received on June 10, 2010, and the last was received on August 25, 2010. The complaints were similar and raised multiple concerns about DHS's oversight of the CDC.

INVESTIGATION

In response to the complaints we conducted a preliminary review. In addition to reviewing information provided by the complainants, we also reviewed:

1. DHS's public licensing file regarding the CDC.
2. Iowa Code chapter 237A ("Child Care Facilities"), which authorizes the DHS to develop and enforce rules setting minimum standards for the licensing of child care centers.
3. Chapter 109 ("Child Care Centers") of DHS's administrative rules (Iowa Admin. Code r. 441—109). Included is a requirement to inspect centers in response to complaints and to maintain a licensing file that is open to the public.

Based on our preliminary review, formal notice of our investigation was issued to then-DHS Director Charles Krogmeier on November 23, 2010. The notice of investigation requested written answers to 11 questions and also requested copies of any and all relevant information.

Mr. Krogmeier responded in an eight-page letter dated January 13, 2011. It was accompanied by hundreds of pages of records in response to our requests. The DHS also provided a computer disc containing approximately 500 internal DHS emails. Some of these emails had attachments which contained additional relevant information.

Based on our review of the available information, we subsequently submitted several separate lists of follow-up questions to the DHS, which responded to those questions. As part of our investigation we have also:

² From this point forward, all dates referenced in this report are from 2010 unless specifically noted otherwise.

1. Reviewed Chapter E, “Child Care Centers,” and its appendix, both from Title 12 of the DHS Employees’ Manual (last revised December 2, 2005).
2. Reviewed “Child Care Centers and Preschools: Licensing Standards and Procedures,” last revised by the DHS in August 2008. This 189-page document offers rationale and recommendations for how to implement the various licensing standards established by statute (Iowa Code chapter 237A) and the administrative rules (Iowa Admin. Code r. 441—109).
3. Conducted sworn interviews of six individuals who were employed by the DHS at the time of the incidents in question and who we identified as likely to have information that would be helpful to our investigation.³

ISSUES INVESTIGATED

The notice of investigation to then-DHS Director Krogmeier identified eight issues that this investigation would focus on. During our investigation, we slightly modified the eight issues. They are:

1. Whether DHS failed to provide timely notice to parents about the seven founded abuse reports regarding incidents that occurred at CDC on or about April 15, 2010, contrary to Iowa Code section 237A.5(2)(k).⁴
2. Whether DHS’s June 4, 2010, letter to parents failed to identify the types of abuse, contrary to section 237A.5(2)(k).
3. Whether DHS has still not provided written notice to CDC parents regarding the types of abuse incidents that occurred at CDC on or about April 15, 2010, contrary to section 237A.5(2)(k).
4. Whether DHS took appropriate and timely follow-up action consistent with law, rules, policies, and practices in considering or reviewing CDC’s license status after reducing the license to provisional status effective April 1, 2010. This includes, but is not limited to, whether DHS took reasonable follow-up actions in determining whether CDC actually acted on DHS’s recommendations.
5. Whether DHS’s failure to notify parents of all CDC children of the provisional license action was unreasonable, even though in accordance with law.
6. Whether DHS actions in editing and/or redacting the original licensing inspection report about the June 3, 2010, incident were inconsistent with policy or based upon improper motivation.
7. Whether DHS provided consumers with regular informational updates on the Internet, as required by Iowa Code section 237A.25(3)(b), following the founded abuse reports involving CDC.

³ Three of the six witnesses are no longer employed by DHS: Jeff Anderson, Denise Gonzales, and JoEllen Spriggs-Dixon.

⁴ The notice of investigation referred to Iowa Code section 237A.5(2)(j). This section was later amended to 237A.5(2)(k). All references to this section in this report will identify it as 237A.5(2)(k).

8. Whether DHS took appropriate and timely follow-up action consistent with law, rules, policies, and practices regarding CDC's "Quality Rating" under the system authorized by section 237A.30 following the founded abuse reports involving CDC.

CHALLENGE TO INFORMATION ACCESS

During this investigation, the DHS was generally cooperative in responding to our requests for information. There was one exception, however, which presented a challenge to our investigation. The computer disc containing DHS's internal emails was accompanied by a memo from Vern Armstrong, Division of Field Operations Administrator. His memo stated:

E-mails have been redacted to remove attorney client privileged communications, with the exception of communications concerning the notification letter to the parents. DHS waives its attorney client privilege as to the communications on that specific subject only.

We eventually identified nine emails on that disc which were either partially or entirely redacted.

A January 26, 2012, letter to DHS Director Charles Palmer requested that the DHS allow our office to have access and asserted the belief that "these emails will help us to understand actions or decisions by the DHS staff related to the licensing issues we are investigating."

In a letter of response dated February 17, 2012, DHS Director Palmer wrote in part:

After consulting with our legal counsel, it is my understanding that the emails in question are not related to the eight issues you have identified as under review. As you know, the Department has waived attorney-client privilege with respect to those matters you have identified as being a part of the investigation. We decline, however, to waive privilege as to other communications that involve pending or threatened litigation.

Iowa Code section 2C.9(4) gives our office broad access to agency information, including confidential records, but it specifically precludes us from examining records "which are the work product of an attorney under section 22.7, subsection, or which are privileged communications under section 622.10."

Nevertheless, the DHS can choose to waive the attorney-client privilege and grant us access to the emails without any redactions. DHS's decision to redact certain emails under the claim of attorney-client privilege leaves our office uncertain as to whether we have obtained all information relevant to this investigation.

DHS'S AUTHORITY TO REGULATE CHILD CARE CENTERS

On an average day in Iowa, more than 75,000 children are cared for in more than 1,500 licensed child care centers, preschools, and before- and after-school programs across the state.

— *From the introduction to a DHS publication, "Child Care Centers and Preschools Licensing Standards and Procedures"*⁵

The DHS is authorized by Iowa Code chapter 237A of the Code of Iowa to regulate the licensing of child care centers. This includes authority to set minimum standards for licensed child care centers and to enforce these standards.

Chapter 237A, entitled "Child Care Facilities," defines "child care facility" as "a child care center, preschool, or a registered child development home." "Child care center" (or "center") is defined as "a facility providing child care or preschool services for seven or more children, except when the facility is registered as a child development home."⁶

Anyone who operates a center without a license can be charged with a crime (serious misdemeanor) under section 237A.19. Such a person can also be restrained by an injunction under section 237A.20.

The licensing process is initiated by filing an application with the DHS. Agency staff then investigates to determine whether the center meets the minimal licensing standards. If the center is found to be in compliance, the DHS "shall" issue a license which is valid for 24 months from the date of issuance. A center's license remains valid unless it is revoked or suspended under section 237A.8, or if it is reduced to a provisional license under section 237A.2(3).

The minimum standards adopted by the DHS are found in its rules in the Iowa Administrative Code (rule 441—109). These include standards relating to:

- Fire safety laws.
- State public health laws.
- The proper ratio of staff to children.
- Staff qualifications, activities, and food services.

By law the DHS can inspect a licensed center at any time. Iowa Code section 237A.4 requires the DHS to make periodic inspections of licensed centers. The same section authorizes the DHS to inspect a center's records and to inquire "into matters concerning these centers and the persons in charge."

⁵ Available at http://www.dhs.state.ia.us/policyanalysis/PolicyManualPages/Manual_Documents/Master/comm204.pdf (last accessed on April 23, 2013).

⁶ Both definitions are in Iowa Code section 237A.1. Our investigation involves DHS's oversight of a business that meets the statutory definition of both a "child care facility" and a "child care center." To avoid confusion, we will refer to it as a "child care center" or "center."

The administrative rules impose several requirements that are not specifically mentioned in the statute. These requirements include the DHS:

- Determine, in response to a complaint received, whether a center is in compliance with the licensing standards. (Iowa Admin. Code r. 441-109.3)
- Make at least one unannounced on-site visit each calendar year. (Iowa Admin. Code r. 441—109.3(1))
- Document, after each visit, whether a center was in compliance and make that document available for public inspection. (Iowa Admin. Code r. 441—109.3(2) and (3))

The responsibility for these licensing duties falls to DHS’s child care consultants. Statewide, the DHS employs 11 child care consultants. Along with a lone supervisor, they are responsible for conducting pre-regulation efforts, licensing, complaint investigations, and any ongoing monitoring and consultation to the 1,500 licensed centers in Iowa.⁷

If child abuse is alleged to have occurred in a center, the child care consultant is required to plan a “collaborative assessment” with the child protection worker.⁸ In such assessments, the DHS Employees’ Manual requires the child care consultant to “focus on compliance issues with the child care licensing rules and law.” If the DHS determines that a child attending a center is the victim of founded child abuse by a center employee, Iowa Code section 237A.5(2)(k) requires the DHS to give notice about the suspension or revocation action to the parents, guardians, and legal custodians of all children served by the center.

If a center violates a provision of chapter 237A, the DHS may—after providing notice and an opportunity for a hearing—suspend or revoke the center’s license under section 237A.8. A violation can also result in a center’s license being reduced to provisional status.⁹

At the same time that the DHS is authorized to “police” child care centers, the DHS is also mandated to act as a consultant to the same centers. This is pursuant to section 237A.6, which states the DHS shall provide consultative services to licensed centers and to those who apply for a license. The purpose of the consultative services is to help centers “in meeting and maintaining the minimum requirements for licensing and then proceeding beyond that level to a program of high quality,” according to the DHS Employees’ Manual.

Jeff Anderson, then-Chief of DHS’s Bureau of Child Care Services, told us these dual roles put the department in the position of “being the bad guy and the good guy at the same time.”

Iowa Code chapter 237A also requires the DHS to:

1. Establish, along with the Department of Education and the Department of Public Health, a leadership council for child care training and development. The council’s charge is to

⁷ According to DHS, the current ratio for licensed centers is 127 centers for each DHS licensing consultant (127:1). Also according to DHS, the National Association of Regulatory Administration (NARA) recommends the ratio of staff to regulated settings should be between 50 – 75:1 to be effective in monitoring compliance.

⁸ This is pursuant to Title 12, Chapter E, of the DHS Employees’ Manual, which is available at http://www.dhs.state.ia.us/policyanalysis/PolicyManualPages/Manual_Documents/Master/12-E.pdf (last accessed on April 23, 2013).

⁹ Pursuant to Iowa Code section 237A.8, we believe the notice and hearing provisions also apply to centers whose license is reduced to provisional status. DHS does not agree, and as a result, centers whose licenses are reduced to provisional status have not been made aware of their right to an appeal hearing. This dispute will be examined in greater detail in a later section of this report.

develop and oversee a system to help people who provide or administer child care services (§ 237A.23).

2. Develop “consumer information material” to help parents select a child care provider (§ 237A.25) and to administer a grant program for child care resource and referral services (§ 237A.26).
3. Help design and implement a voluntary quality rating system for child care facilities, including centers (§ 237A.30).

CHRONOLOGY

This chronology is based primarily on publicly available licensing records from the DHS. Some portions of this chronology are based on information obtained as a result of the Ombudsman's investigation. **For the remainder of this report, all dates are in 2010 unless otherwise noted.**

Over a three-month period—March 18 to June 17—the DHS received five complaints about the CDC. Each complaint was investigated by Child Care Licensing Consultant JoEllen Spriggs-Dixon. Based on her investigations, Spriggs-Dixon generated seven “Child Care Center Complaint” reports.¹⁰ From this point forward we will refer to these as “complaint reports.”

1. March 18 – The DHS received a licensing-related complaint about the Child Development Center (CDC). It was alleged the CDC was in violation of DHS's ratio standards (the number of children per teacher).

It was also alleged that a three-year old boy had been acting out sexually with other children and that CDC's two administrators had been ignoring staff's reports about the sexual behaviors.

2. March 23 – DHS Child Care Licensing Consultant JoEllen Spriggs-Dixon visited the CDC to investigate the complaint.
3. March 29 – Spriggs-Dixon completed her investigation and submitted her report to CDC (Complaint Report #1). According to the report, she found CDC was in violation of the ratio requirements. CDC's two administrators said they were in the process of hiring new employees for three open positions; it was believed those new hires would bring the CDC into compliance for ratios.

Also according to Spriggs-Dixon's report, CDC's two administrators denied being made aware of a child acting out sexually with other children. Spriggs-Dixon determined the sexually inappropriate behaviors likely did occur. “It is troubling that both administrators deny knowing about these numerous incidents,” she wrote, “because this indicates there may be a serious communication gap between staff and administrators.”

Spriggs-Dixon's report recommended CDC's two administrators discuss with staff “the importance of sharing information regarding children's abnormal behaviors ... so that appropriate steps can be taken, up to and including reporting to DHS.”

4. March 30 – Spriggs-Dixon reopened her investigation into whether CDC administrators had ignored reports of a child acting out sexually with other children. There is no record of what prompted Spriggs-Dixon to reopen the investigation and when we interviewed her she could not recall. She conducted the reinvestigation jointly with another DHS worker, Suzanne Laurence.
5. March 31 – Spriggs-Dixon made a second visit to the CDC to assess the ratios issue.
6. March 31-May 10 – Spriggs-Dixon and Laurence conducted numerous interviews for the reinvestigation of the sexual behaviors complaint. Interviewees included parents of two

¹⁰ Spriggs-Dixon produced one report for each of three complaints. She produced two reports for each of the other two complaints. This explains why there were seven reports in response to five complaints.

children, as well as several CDC employees and two ex-employees of CDC who had been fired soon after Spriggs-Dixon began her first investigation on March 23.

7. April 8 – Spriggs-Dixon submitted a second report to CDC (Complaint Report #2) regarding the ratios issue. According to Complaint Report #2, CDC administrators said they were still in the process of hiring new staff. “These planned hires should correct ratio deficiencies,” Complaint Report #2 concluded. “A follow-up visit will be conducted.”
8. April 13 – Spriggs-Dixon received a new complaint alleging a CDC teacher had slapped a three-year-old girl and was routinely “rough” with children. It was also alleged that the same teacher had talked about “getting high” on lunch break and then going back to work.
9. April 16 – Spriggs-Dixon visited the CDC to investigate the new complaint.
10. April 29 – Spriggs-Dixon completed her investigation into the new complaint and submitted her report to CDC (Complaint Report #3). According to Complaint Report #3, Spriggs-Dixon found the teacher had engaged in “a pattern of passive aggressive to active aggressive care.”

“From swatting children’s heads and grabbing their arms, to hitting their faces and causing a bleeding nose, a red mark and a scratch, (the teacher’s) treatment of children is cause for eminent concern,” Complaint Report #3 said.

Regarding the marijuana allegation, the report said the teacher admitted smoking marijuana outside of work, but denied doing so during her breaks. Spriggs-Dixon asked the teacher to submit to a drug test, but the teacher had not done so as of April 29. We were unable to find any additional records regarding this issue. Complaint Report #3 concluded both allegations were confirmed and that the teacher’s behaviors “are placing children at risk of harm and causing injuries.”

11. May 18 – Spriggs-Dixon completed her reinvestigation of the sexual behaviors complaint and submitted her report to CDC (Complaint Report #4). According to Complaint Report #4, she found CDC’s two administrators and CDC’s therapist had ignored reports from staff about a child who had been acting out sexually with other children. Complaint Report #4 also expressed concern that CDC’s recent firing of two employees may have been in retaliation for reporting information to the DHS.

Complaint Report #4 stated CDC’s license was being reduced to provisional status. The report also imposed a number of “actions required” on CDC (actions needed to correct various violations) and required CDC to submit a written response by June 18.

12. May 21-June 3 – DHS management rewrote Complaint Report #4. The main purpose of the rewrite was to remove any suggestion that the firings may have been out of retaliation. While DHS’s public licensing file includes a copy of both the original version and the revised version of Complaint Report #4, there is no record that DHS ever submitted the revised version to CDC.
13. June 4 – The DHS addressed a letter to all parents, guardians, and legal custodians of children attending CDC. DHS’s letter stated in part, “This notification is to inform you that there were seven confirmed reports of child abuse at CFI Child Development Center.

The incidents occurred on or about April 15, 2010, at the center, were assessed, founded, and placed on the central registry for child abuse as required by law.¹¹ If your child had been involved you would have been contacted during the assessments. Please note that the confirmed reports are subject to appeal. If appeals are successful, the reports could be modified or removed from the central registry. You will be notified if the findings are overturned or modified from appeal.”

14. June 4 – Spriggs-Dixon received a new complaint about a June 3 incident at CDC. It was alleged that four boys who were not being supervised had engaged in sexual behavior with each other.
15. June 7 – Spriggs-Dixon received another new complaint alleging new teachers were not always verifying whether individuals picking up kids were authorized to do so.
16. June 8 – Jeff Anderson, then-Chief of the Bureau of Child Care Services, sent CDC a formal notice that its child care center license was being reduced to provisional status for one year, effective from April 1, 2010, to April 1, 2011.
17. June 14 – Spriggs-Dixon completed her investigation of the June 3 incident and submitted her report (Complaint Report #5) to her supervisor. Spriggs-Dixon’s report found that the sexual behavior in the June 3 incident was extremely age-inappropriate, with numerous references to penises being touched, shaken, and sucked. Complaint Report #5 found several licensing-related violations had contributed to the incident. The report included Spriggs-Dixon’s recommendation that the DHS should revoke CDC’s license if the June 3 incident resulted in any additional founded child abuse reports.
18. June 17 – Spriggs-Dixon received a new complaint from a parent who alleged she had not received any incident reports from the CDC since April 2009 (approximately 14 months).¹²
19. Week of June 17 – At the direction of her supervisor, Spriggs-Dixon revised Complaint Report #5 to remove the revocation recommendation. Around the same time, the supervisor advised Spriggs-Dixon that Complaint Report #5 contained too many “penis” references and would be subject to further revisions by management.
20. June 18 – The DHS received the written corrective action plan from CDC in response to the “required actions” detailed in Complaint Report #4.
21. June 21 – Spriggs-Dixon visited the CDC to assess the two most recent complaints. This included the allegation that new teachers were not always verifying whether individuals were authorized to pick up kids and the allegation that a parent had not received any incident reports since April 2009. While there, Spriggs-Dixon also evaluated CDC’s progress on the “visual obstructions” deficiency which was not addressed in CDC’s Corrective Action Plan even though it had been cited in Complaint Report #4.

¹¹ Based on our investigation, we believe the April 15 reference is at least somewhat inaccurate. The incidents that led to six of the founded abuse reports occurred prior to April. We were unable to determine why DHS’s letter indicated all of the incidents occurred on or about April 15.

¹² Iowa Administrative Code rule 109.10(10) states, “Incidents involving a child, including minor injuries, minor changes in health status, or behavioral concerns, shall be reported to the parent on the day of the incident. Incidents resulting in an injury to a child shall be reported to the parent on the day of the incident. Incidents resulting in a serious injury to a child or significant change in health status shall be reported immediately to the parent. A written report shall be provided to the parent or person authorized to remove the child from the center.”

22. June 22 – Spriggs-Dixon completed her investigation into the allegation that new teachers were not always verifying whether individuals were authorized to pick up kids and submitted her report to CDC (Complaint Report #6). While it found the new complaint was unsubstantiated, Complaint Report #6 said the CDC’s progress towards correcting the “visual obstructions” deficiency was lacking.
23. June 23 – On her final day of employment before retirement, Spriggs-Dixon completed her investigation into the complaint received on June 17 and submitted her report to CDC (Complaint Report #7). According to the report, Spriggs-Dixon determined CDC staff had not been writing incident reports as required by the licensing standards. CDC staff said they were already attempting to correct this deficiency.
24. July 8 – Ric Hirst, DHS Child Care Licensing Supervisor, visited the CDC and found the CDC had made significant progress towards correcting the “visual obstructions” deficiency previously cited by Spriggs-Dixon.
25. July 12 – The DHS addressed a letter to all parents, guardians, and legal custodians of children attending CDC. DHS’s letter stated there were “eight confirmed reports of child abuse, specifically Denial of Critical Care for Lack of Proper Supervision, at the [CDC]. The incidents that occurred on or about June 3, 2010 at the center, were assessed, founded, and placed on the central registry for child abuse as required by law.... Please note that the confirmed reports are subject to appeal. If appeals are successful, the reports could be modified or removed from the central registry. You will be notified if the findings are overturned or modified from appeal.”
26. July 14 – The DHS addressed a letter to parents, guardians, and legal custodians of children attending CDC. DHS’s letter was a follow-up to the June 4 letter, which said there had been seven confirmed reports of child abuse regarding incidents that had occurred on April 15. DHS’s July 14 letter stated, “This notification is to inform you there were seven confirmed reports of child abuse, specifically Denial of Critical Care for Lack of Proper Supervision, at the [CDC].¹³ Please note that a notification was sent to you on June 4, 2010 however we did not inform you as to the type of abuse. We apologize for the oversight.”
27. July 14 – DHS Deputy Director Titus addressed a letter of response to a legislator who had inquired about DHS’s oversight of the CDC. Titus’ letter acknowledged at least two errors in DHS’s handling of the matter: Delay in notifying parents about the initial seven founded abuse reports; and the June 4 letter to parents did not identify the types of abuse. Titus’ letter also stated that the DHS “will continue to work with the agency to ensure that necessary and sufficient changes are implemented.”
28. Late July – The DHS sent CDC a revised version of Complaint Report #5, in which many of the “penis” references were removed.
29. March 15, 2011 – Child Care Licensing Consultant Nate Knepper visited the CDC and conducted an eight-hour long licensing visit. This was DHS’s first visit to the CDC since Hirst’s July 8, 2010, visit.

¹³ DHS’s July 14 letter to families did not correctly identify the seven confirmed abuse reports. In fact, six of the confirmed reports involved Denial of Critical Care for Lack of Proper Supervision, and one involved Physical Abuse.

“Last year’s licensing violations were checked and all of them have been corrected,” Knepper’s report stated. He also wrote, “A full license is recommended at this time. There are some issues that still remain, but many of these issues were inherited from the previous director. The current director and her staff have a plan in place to correct these issues and are slowly, but surely getting these issues corrected.”

30. August 2, 2011 – The DHS addressed a letter to all parents, guardians, and legal custodians of children attending CDC. DHS’s letter stated in part, “You were previously informed that there were seven confirmed reports of child abuse, specifically Denial of Critical Care for Lack of Proper Supervision, at the Children and Families of Iowa – Child Development Center that occurred on or about April 15, 2010.... A final decision has now been reached in each of the abuse cases and the findings of abuse were either overturned to unfounded or modified to confirmed, not placed on the child abuse registry.”¹⁴

¹⁴ While most of the other eight found reports were also modified, the DHS told our office that they had not given notice of that fact to the families.

ISSUE #1

Whether DHS failed to provide timely notice to parents about the seven founded abuse reports regarding incidents that occurred at CDC on or about April 15, 2010, contrary to Iowa Code section 237A.5(2)(k)

RELEVANT STATUTE

Iowa Code section 237A.5(2)(k) states:

If it has been determined that a child receiving child care from a child care facility or a child care home is the victim of founded child abuse committed by an employee, license or registration holder, child care home provider, or resident of the child care facility or child care home for which a report is placed in the central registry pursuant to section 232.71D, **the administrator shall provide notification at the time of the determination** to the parents, guardians, and custodians of children receiving care from the child care facility or child care home. A notification made under this paragraph shall identify the type of abuse but shall not identify the victim or perpetrator or circumstances of the founded abuse. (emphasis added).

FINDINGS OF FACT

The DHS addressed a June 4 letter to parents, guardians, and legal custodians of all children attending CDC. The letter stated in part:

This notification is to inform you that there were seven confirmed reports of child abuse at (the child care center). The incidents occurred on or about April 15, 2010, at the center, were assessed, founded, and placed on the central registry for child abuse as required by law. If your child had been involved you would have been contacted during the assessments.¹⁵

Please note that the confirmed reports are subject to appeal. If appeals are successful, the reports could be modified or removed from the central registry. You will be notified if the findings are overturned or modified from appeal.

Among those seven confirmed reports of abuse, DHS records show departmental staff made six of those determinations by April 28. DHS records also show the seventh determination was reached on or about May 13. The letter to parents was dated June 4, more than a month after the first six determinations and about three weeks after the seventh and final determination.

In a subsequent letter of response to a legislator's inquiry, Sally Titus, DHS Deputy Director for Programs and Services, acknowledged that the DHS failed to provide timely notice to parents about the seven above-mentioned founded abuse reports:

Due to an internal miscommunication and new persons in new roles, the letter to parents regarding this situation was not sent out until June 4, 2010. We recognize that this time lag is unacceptable and have taken steps to assure that we do not have a delay like this going forward.

¹⁵ Based on our investigation, we believe the April 15 reference is at least somewhat inaccurate. The incidents that led to six of the founded abuse reports occurred prior to April. However, we were unable to determine why DHS's letter indicated all of the incidents occurred on or about April 15.

The DHS said it was not aware of any other such notifications in 2010 which were not sent timely. Then-DHS Director Charles Krogmeier's January 13, 2011, letter of response to our notice of investigation said the DHS had developed new procedures designed to ensure timely notification to parents when there is a founded child abuse assessment involving a licensed child care facility.

The DHS said these new procedures include the following steps:

- Ten (10) days for the center to submit the names and addresses of parents, guardians, and custodians of all children served at the center (to allow time for the care center to ensure accuracy of their parent contact database).
- Ten (10) days from receipt of that information for the DHS division administrator to provide notice to the families (to allow for the letter to be drafted and the parent contact database applied).
- Sixty (60) days for the entire process to be completed. This includes time for the child abuse assessment to be completed (approximately 30 days); any additional licensing follow-up (approximately 20 days); and for the acquisition and distribution of parent letters (if applicable).

The DHS said it has “established and adopted the process and assigned duties associated with timely parent notification. Licensing staff was trained in November 2011.” Although this process has not yet been reflected in policy or rule, DHS anticipates issuing a manual letter regarding this process by August 2013.

CONCLUSION

We conclude that the DHS failed to provide timely notice to parents about the seven founded abuse reports that occurred at CDC in spring 2010, contrary to Iowa Code section 237A.5(2)(k).

RECOMMENDATION

1. The DHS should amend its administrative rules and Employees' Manual to reflect the new procedures described above.

ISSUE #2

Whether DHS's June 4, 2010, letter to parents failed to identify the types of abuse, contrary to Iowa Code section 237A.5(2)(k)

ISSUE #3

Whether DHS has still not provided written notice to CDC parents regarding the types of abuse incidents that occurred at CDC on or about April 15, 2010, contrary to Iowa Code section 237A.5(2)(k)

RELEVANT STATUTE

Iowa Code section 237A.5(2)(k) states:

If it has been determined that a child receiving child care from a child care facility or a child care home is the victim of founded child abuse committed by an employee, license or registration holder, child care home provider, or resident of the child care facility or child care home for which a report is placed in the central registry pursuant to section 232.71D, the administrator shall provide notification at the time of the determination to the parents, guardians, and custodians of children receiving care from the child care facility or child care home. **A notification made under this paragraph shall identify the type of abuse** but shall not identify the victim or perpetrator or circumstances of the founded abuse. (emphasis added).

FINDINGS OF FACT

These two issues both relate to the information the DHS was mandated to provide to families of children attending the CDC about the seven founded abuse reports that occurred in spring of 2010.

In a May 27 letter of response to a legislator's inquiry, DHS Deputy Director Titus wrote in part:

Iowa Code section 237A.5(2)j mandates that [DHS] child care licensing consultant notify parents, guardians and custodians of children receiving care at the center when it has been determined that center staff are the perpetrators of founded abuse towards a child at the center. **The notification is to identify the type of abuse** but is not to identify the victim or perpetrator or circumstances of the founded abuse. (emphasis added).

The following week, then-Child Care Consultant JoEllen Spriggs-Dixon drafted a letter for the purpose of meeting the notification requirements in section 237A.5(2)(k). Spriggs-Dixon's draft letter identified the types of abuse. "I always identified the forms of abuse," Spriggs-Dixon told us, referring to similar letters she had previously sent out to parents—without objection—over her 22-year-long career as a DHS Child Care Consultant before retiring in late June.

On June 2, Spriggs-Dixon emailed her draft letter to Ric Hirst, DHS's Child Care Licensing Supervisor, and to Assistant Attorney General Tabitha Gardner. Spriggs-Dixon's email asked for approval to send the letter out.

Hirst replied:

We will not be sending any notice out until Denise Gonzalez gives clearance. I would also think that with the interest this event has generated in the Hoover [*sic*] we would probably want to go with the simplest of notifications.

Later the same day Hirst sent another email to Spriggs-Dixon, “I am not sure we can ... describe that one of the abuses was physical. Under rule we can barely acknowledge that there was abuse.”

In response, Spriggs-Dixon sent Hirst an email which asked, “Is there a specific rule that states that we can’t mention it; or a reason why we would keep this information from them?” We were unable to locate any email in which Hirst responded to that question.¹⁶

The next day, June 3, Hirst sent an email to his supervisor, Denise Gonzales, Manager of the Centralized Service Area, which stated in part:

I told JoEllen that the type of abuse and result did not have to be described. Our job is to notify parents that there has been abuse. That’s it.

The DHS addressed a June 4 letter to parents, guardians, and legal custodians of all children attending CDC. The letter, which did not identify the types of abuse, stated in part:

This notification is to inform you that there were seven confirmed reports of child abuse at (the child care center). The incidents occurred on or about April 15, 2010, at the center, were assessed, founded, and placed on the central registry for child abuse as required by law. If your child had been involved you would have been contacted during the assessments.¹⁷

Please note that the confirmed reports are subject to appeal. If appeals are successful, the reports could be modified or removed from the central registry. You will be notified if the findings are overturned or modified from appeal.

On June 7, Hirst sent an email to Clerk Specialist Marsha McBee, stating:

I have told her [*Spriggs-Dixon*] that I agree with her positions and the importance of protecting children and notifying parents. The rub comes with how we are able to tell the parents and how much we can let them know before it would destroy the business that a center has.

DHS Deputy Director Titus’ subsequent July 14 letter of response to a legislator’s inquiry acknowledged the June 4 letter had failed to identify the types of abuse, contrary to section 237A.5(2)(k). Titus’ letter stated in part:

As you have noted the letter dated June 4th did not contain the required information about the type of abuse. Although our staff reviewed the draft letter with the Attorney General’s Office prior to sending, they did not follow our policy. We have reviewed our policy with them to assure that this will not happen again. We are forwarding a revised letter regarding the incident that clarifies that there were concerns about supervision and physical abuse.

¹⁶ We were unable to interview Hirst for this investigation, as he died in November 2010.

¹⁷ As explained in the previous section, we believe the April 15 reference is at least somewhat inaccurate.

Separately, the DHS addressed a July 14 letter to parents, guardians, and legal custodians of all children attending the CDC. Signed by Wendy Rickman, Division Administrator for Adult, Children and Family Services, that letter stated in part:

This notification is to inform you there were seven confirmed reports of child abuse, specifically Denial of Critical Care for Lack of Proper Supervision, at the [CDC]. **Please note that a notification was sent to you on June 4, 2010 however we did not inform you as to the type of abuse. We apologize for the oversight.** (emphasis added).

Rickman's letter did not correctly identify the seven confirmed abuse reports. In fact, six of the confirmed reports involved Denial of Critical Care for Lack of Proper Supervision, and one involved Physical Abuse.

The same error was repeated a year later in a letter the DHS sent to the same parents, custodians, and guardians. The letter, dated August 2, 2011, and also signed by Rickman, stated in part:

You were previously informed that there were seven confirmed reports of child abuse, specifically Denial of Critical Care for Lack of Proper Supervision, at the Children and Families of Iowa – Child Development Center that occurred on or about April 15, 2010....

A final decision has now been reached in each of the abuse cases and the findings of abuse were either overturned to unfounded or modified to confirmed, not placed on the child abuse registry.

We asked the DHS why its notice to parents had improperly identified the breakdown of the seven confirmed reports of child abuse. DHS's response stated:

DHS was in error with the content of the notice to parents. To prevent this issue from recurring, a policy/practice work group was formed in August 2011 and training was provided in November 2011.

CONCLUSION

Based on this information, we conclude:

- The DHS's June 4 letter to parents failed to identify the types of abuse, contrary to section 237A.5(2)(k)
- The DHS has still not provided accurate information to CDC parents regarding the types of abuse incidents that occurred at CDC in spring 2010, contrary to section 237A.5(2)(k).

RECOMMENDATION

2. The DHS should consider whether it would be appropriate to provide a follow-up communication to then-CDC parents to clarify the types of abuse incidents that occurred at CDC in spring 2010.

ISSUE #4

Whether DHS took appropriate and timely follow-up action consistent with law, rules, policies, and practices in considering or reviewing CDC's license status after reducing the license to provisional status effective April 1, 2010

RELEVANT STATUTES, RULES, AND POLICY

The DHS is authorized by Iowa Code chapter 237A to regulate the licensing of child care centers. This includes authority to set minimum standards for licensed child care centers and to enforce these standards.

If a center violates a provision of chapter 237A, the DHS may suspend or revoke the center's license under section 237A.8. This section requires the DHS to give notice about the suspension or revocation action to the parents, guardians, and legal custodians of all children served by the center. A violation can also result in a center's license being reduced to provisional status.

These enforcement options are described in greater detail in DHS's administrative rules (Iowa Admin. Code r. 441—109).

Suspended and revoked licenses

Sub-rule 109.2(5) states a license shall be revoked or suspended if corrective action has not been taken when:

- a. The center does not comply with center licensing laws or these rules.
- b. The center is operating in a manner which the department determines impairs the safety, health, or well-being of the children in care.
- c. A person subject to an evaluation has transgressions that merit prohibition of involvement with child care and of licensure, as determined by the department.
- d. Information provided to the department or contained in the center's files is shown to have been falsified by the provider or with the provider's knowledge.
- e. The facility is not able to obtain an approved fire marshal's certificate as prescribed by the state fire marshal in 661—Chapter 5 or Iowa Code chapter 100 or fails to comply in correcting or repairing any deficiencies in the time determined by the fire marshal or the fire marshal determines the facility is not safe for occupancy.
- f. The regulatory fee as specified in subrule 109.2(7) is not paid in full due to insufficient funds to cover a check submitted to the department for the fee.

Additional guidance is offered in the DHS publication, "Child Care Centers and Preschools Licensing Standards and Procedures."¹⁸ This publication includes a section which states:

¹⁸ Available at http://www.dhs.state.ia.us/policyanalysis/PolicyManualPages/Manual_Documents/Master/comm204.pdf (last accessed on April 23, 2013).

The Department may initiate an action to suspend a license to address an issue of noncompliance that may be temporary. An example is a center unable to use its licensed facility due to floodwaters or a fire.

The Department may initiate an action to revoke a license when the center exhibits a pattern of noncompliance or an imminent concern arises that jeopardizes the well-being of children.

Provisional licenses

Asked about the purpose of reducing a license to provisional status, Renee Larsen, then-Child Care Regulatory Program Manager, explained:

The goal is to assist the child care center facility into coming into compliance. It is putting them on notice so to speak that violations are serious—one step away from revoking. It's kind of like being on probation.

Sub-rule 109.2(3) states:

- a. A provisional license may be issued or a previously issued license may be reduced to a provisional license for a period up to one year when the center does not meet all standards imposed by law and these rules.
- b. A provisional license shall be renewable when written plans giving specific dates for completion to bring the center up to standards are submitted to and approved by the department. A provisional license shall not be reissued for more than two consecutive years when the lack of compliance with the same standards has not been corrected within two years.
- c. When the center submits documentation or it can otherwise be verified that the center fully complies with all standards imposed by law or these rules, the license shall be upgraded to a full license.

The DHS Employees' Manual further states, "Two or more visits to the facility may be required in order to complete a thorough evaluation. Return visits are essential for new applicants and facilities with provisional licenses."¹⁹

Minimum standards

The minimum standards adopted by the DHS are found in DHS's administrative rules. These include rules relating to:

- The proper ratio of staff to children. (Iowa Admin. Code r. 441—109.8).
- Rooms are to be arranged "so as not to obstruct the direct observation of children by staff." (Iowa Admin. Code r. 441—109.12(4)).
- "Incidents involving a child, including minor injuries, minor changes in health status, or behavioral concerns, shall be reported to the parent on the day of the incident. Incidents resulting in an injury to a child shall be reported to the parent on the day of the incident. Incidents resulting in a serious injury to a child or significant change in health status shall

¹⁹ From page 11 of Chapter E, Title 12 of the DHS Employees' Manual.

be reported immediately to the parent. A written report shall be provided to the parent or person authorized to remove the child from the center.” (Iowa Admin. Code r. 441—109.10(10)).

FINDINGS OF FACT

Over a three-month period—March 18 to June 17— the DHS received five complaints about the CDC. Child Care Licensing Consultant JoEllen Spriggs-Dixon investigated the complaints and prepared seven “Child Care Center Complaint” reports.²⁰

Our investigation has focused primarily on the two reports which were in direct response to complaints about staff’s responses to children’s sexual behaviors. We will be referring to these specific reports as Complaint Report #4 and Complaint Report #5,²¹ because they were the fourth and fifth such reports, respectively, generated by Spriggs-Dixon.

On May 18, the DHS mailed Complaint Report #4 to the CDC. The report said the DHS had received a complaint which alleged:

There is a three-year old boy who has been caught with his hands in other children’s pants, or he has had other children touch his penis. This has happened three to four times. Once it involved another child, a girl. The two children were caught with their hands down each other’s pants, and lying on top of each other. When staff brought it to the supervisor’s attention, they were told to let it go; that it was no big deal; that they were just kids being kids. But the boy’s language seems more like an adult. The boy has said, “I’m going to stick my dick in your ass.”

Complaint Report #4 described the findings from Spriggs-Dixon’s investigation, along with her conclusion that CDC administrators had ignored reports from staff about children acting out sexually. “All of the staff expressed frustration regarding what they perceived as the administrators’ dismissive attitude and lack of support in dealing with children’s behaviors,” the report said, adding:

The convergence of several factors appears to have set the stage for critical supervision deficiencies. Those factors include the presence of so many children with challenging behaviors, improper ratios (as noted in a complaint dated 3/23), a lack of staff training and program structure, and most important, a lack of administrative instruction and support on establishing clear boundaries and limits for children. The children engaged in blatant inappropriate sexual behaviors without proper interventions. It is not surprising that children’s behaviors evolved from exposing and grabbing private parts to laying on top of each other with hands down each other’s pants, or that these behaviors spread to a third child.

Complaint Report #4 also discussed the “perception that at least two staff have been terminated for reporting their concerns to DHS.” While stating that “retaliation is hard to prove,” the report added:

Because child care staff are in the best position to observe and report non compliance with licensing standards, their sense of safety from retaliation by the

²⁰ Spriggs-Dixon produced one report for each of three complaints. She produced two reports for each of the other two complaints. This explains why there were seven reports in response to five complaints.

²¹ It may be helpful to refer back to a previous section in this report, titled “Chronology.”

center is of critical interest to DHS. Whether intended or not, the termination of the two employees almost directly following their reports to the licensing consultant sent a chilling message to staff that they might be discharged if they reported to DHS. At least two staff stated that they were concerned that they would be retaliated against for speaking with the DHS investigators.

The conclusion of Complaint Report #4 stated:

Based upon the numerous licensing violations cited, the status of the license is being changed from full to provisional. The center will need to correct those cited areas, and provide the consultant with a written plan of correction that includes a detailed description of each remedy. **The written plan of correction should include documentation that staff have completed the required training as set forth in this report.** It should also include copies of revised policies. **The licensing consultant should receive the written notice of corrections no later than June 18, 2010. If training has not been taken by that time, scheduled times for training should be included.** (emphases added).

On June 4, Spriggs-Dixon received a new complaint about an incident the day before in which four boys at the CDC reportedly engaged in sexual behavior while not being directly supervised. The June 3 incident did not involve the same children or even the same classroom as the prior incidents. The earlier incidents involved three-year-olds, while the June 3 incident involved five-year-olds.

On June 8, Jeff Anderson, then-Chief of the Bureau of Child Care Services, sent CDC a formal notice that its child care center license was being reduced to provisional status for one year, effective from April 1, 2010, to April 1, 2011. In an interview, Anderson confirmed that notice was in response to Complaint Report #4 and was not related to DHS's then-pending investigation regarding the June 3 incident.

On June 10, Ric Hirst, then-Child Care Licensing Supervisor, emailed his supervisor, Denise Gonzales, then-Manager of DHS's Centralized Service Area, to provide an update on Spriggs-Dixon's investigation into the June 3 incident. Hirst's email stated in part, "We are not planning on any revocation."

On June 14, after completing her investigation into the June 3 incident, Spriggs-Dixon submitted her report (Complaint Report #5) to Hirst, her supervisor. Complaint Report #5 was based in large part on interviews of the four boys and the two teachers who had been assigned to supervise them.

Complaint Report #5 described the boys' account of what happened when they found themselves alone, unsupervised, in a largely enclosed play area at the CDC. Spriggs-Dixon was unable to determine with any accuracy the length of time the boys were alone in the play area. Whatever the duration, it was long enough for the boys to engage in sexual behavior that was extremely inappropriate, going beyond what had been described in Complaint Report #4. Complaint Report #5 included numerous references to penises being touched, shaken, and sucked.

Complaint Report #5 identified several contributing factors for the June 3 incident:

1. Neither teacher had been made aware by CDC administrators of the previous sexualized behaviors involving children in other classrooms. "They had not received any training on prevention, nor have they been told what to do if such an incident occurred," the report stated.

2. While Complaint Report #4 had required CDC to identify and remove “any obstructions to visual supervision,” the June 3 incident occurred in an area that was almost entirely enclosed and effectively obstructed from the view of the teachers. Complaint Report #5 concluded, “The fact that such an obvious obstruction to visual supervision still exists in this center’s environment after the clear warning to remedy such, is an indication that the previous regulatory instruction was not taken seriously.”
3. While two teachers were assigned to the room, one teacher was focused on treating a child who had bumped and cut his head on the playground. The other teacher had left the room to attend to other matters.
4. The teachers were aware two of the boys engaged in more mature play when they were together and usually tried to keep them separated. But “on this occasion staff seemed to have abandoned any situational awareness” and allowed the two boys to be together, DHS’s report stated.

Complaint Report #5 also found that CDC staff did not immediately notify the parents of the four children involved in the June 3 incident. According to Complaint Report #5, the incident occurred between 11 a.m. and 11:30 a.m., but at least one parent was not notified until 4:20 p.m. By contrast, CDC staff provided immediate notification to the parent of the child who had been injured on the playground.

“This incident represents a serious change in the children’s emotional and mental health status,” Complaint Report #5 said. “This should have been reported to the parents immediately so that they could have the opportunity to address the serious issue of their children’s exposure to inappropriate sexual activity.”

Spriggs-Dixon’s report included a conditional recommendation: If the June 3 incident resulted in any additional founded child abuse reports against CDC staff, the DHS should begin the process of revoking CDC’s license.²² Spriggs-Dixon, who had been employed as a Child Care Licensing Consultant for 22 years, had been the catalyst for several previous revocations of other child care center licenses. According to Spriggs-Dixon, in all of her revocation cases that went to a contested case hearing before an administrative law judge, the revocation was upheld.

In a June 14 email, Hirst forwarded Complaint Report #5 to Gonzales. She responded, “I am concerned about the final piece of her report- revocation? I thought you did not think this would be the recommendation?”

Hirst replied to Gonzales:

If we are going to go for revocation yes. Plus she was trained by Tabitha [Gardner, Assistant Attorney General] for this type of complaint. I want the last two paragraphs modified. I would phrase it “upon receipt of the corrective action plan a determination of licensing status will be made.” That will cover us for whatever we decide to do.

Complaint Report #5 was also forwarded to Jeff Anderson, then-Chief of the Child Care Services Bureau. After reviewing the report, Anderson emailed his supervisor, Wendy Rickman, Administrator of the Division for Adult, Children and Family Services. Anderson’s June 15 email stated:

²² In fact, the June 3 incident led to eight new confirmed reports of child abuse involving CDC staff, according to DHS’s July 12 letter to parents, guardians, and legal custodians.

These are some serious findings, especially in light of the last assessment. While some opinions do appear by the writer regarding the reports of staff versus the children, children who were already known to have some acting out behaviors were not being carefully supervised.

Has there been discussion/conversation with the CFI director? It appears the recommendations of the last assessment have not been resolved sufficiently. Even if PBS training²³ was not able to be accessed in the short time frame, I do not see where alternatives, such as the therapist providing some training to the staff, or that this was offered by CFI as an alternative since the last assessment.

I do not see a conflict with policy and revocation in order. The big problem, from a child protective and intervention stance, is where the children can be served.

In an interview, Anderson said the main point of his email to Rickman was that he believed suspension or revocation would have been allowable by policy. He clarified he was not advocating for or against a suspension or revocation. Anderson said any such action “would had to have been a consensus decision.”

Also on June 15, Hirst emailed Spriggs-Dixon and asked her to remove her revocation recommendation from Complaint Report #5. Spriggs-Dixon’s email response explained why she wanted to keep the sentences about a possible revocation in the report:

I think they send a clear message that the center’s operations are extremely out of line with the most basic care practices. And they are in dire need of competent leadership. It also seems more fair, and a part of due process, to inform centers of the possible considerations and consequences with regard to 109.2(3)-(6), because this rule falls under the revocation/suspension part of the Code.

Revocation is one of the licensing tools that I have used successfully to leverage change; to help keep a center open and operating so that children are safe.²⁴

Despite her protests, Spriggs-Dixon soon thereafter rewrote the report to remove her revocation recommendation, creating a new version—Revised Complaint Report #5.

On or about June 17, Spriggs-Dixon said, she was informed by Hirst that Revised Complaint Report #5 contained too many references to the word “penis” and would be rewritten. Over the following weeks, Hirst rewrote Revised Complaint Report #5, primarily to remove many of the “penis” references. This resulted in a new version—Final Complaint Report #5—which the DHS believes it mailed to CDC towards the end of July.

On June 18, the DHS received CDC’s written response to the required actions in Complaint Report #4.²⁵ Through this investigation we could not find any record of the DHS approving CDC’s Corrective Action Plan in 2010.

On June 21, Spriggs-Dixon visited the CDC to assess two new complaints and to evaluate CDC’s progress towards correcting the “visual obstructions” deficiency. Based on her investigation,

²³ Positive Behavior Supports training.

²⁴ In an interview, Spriggs-Dixon explained that initiating the revocation process does not always result in an actual revocation of a center’s license. For example, if the DHS subsequently determines that the center has corrected the licensure violations that triggered the revocation action, the DHS can dismiss the revocation action.

²⁵ CDC’s five-page written response was titled, “June 18, 2010 Response to DHS Complaint Report and Required Actions.” For the remainder of this report, we will refer to this document as “CDC’s Corrective Action Plan.”

Spriggs-Dixon determined one of the new complaints was substantiated while the other was not substantiated.²⁶

Spriggs-Dixon also found the CDC's progress towards correcting the "visual obstructions" deficiency was lacking. This is according to the Child Care Center Complaint report Spriggs-Dixon completed on June 22 (Complaint Report #6), which stated in part:

The corrective action requirement regarding visual supervision has not been fully addressed, nor was it addressed in [CDC's *Corrective Action Plan*].²⁷ This is one of the most critical pieces in preventing future violations regarding the failure to provide careful supervision. Until this issue has been convincingly addressed and resolved; and until the center provides documentation that all required training has been completed; and until those areas that have a written claim of correction have been sustained for a convincing period of time, I am recommending that the center continue under a provisional license.

On July 7, Anderson received an email inquiry from Julie Allison, Chief of DHS's Bureau of Child Welfare and Community. Allison's email said Sally Titus, DHS Deputy Director for Programs and Services, wanted to know about the timeframes relating to corrective action plans. Anderson's email response said, "There not a specific timeframe for completing a corrective action plan. All we have regarding monitoring a corrective action plan is that, 'Return visits are essential for new applicants and facilities with provisional licenses.'"²⁸

In a second email, Anderson clarified, "There is not a specific timeframe for submitting their corrective action."

On July 8, about two weeks after Spriggs-Dixon's retirement, Hirst visited the CDC along with a child care licensing consultant. Hirst described his findings in a July 8 email to his supervisor, Denise Gonzales:

They have open [*sic*] up the dramatic play area to make it more visible to all staff. They have installed security mirrors on the upper level corners of several rooms for teachers to better observe their entire area. Teachers are now spread out through the entire active play area instead of "clumping" up together. Site lines look much better. Christina appears to be pretty good.

Gonzales responded by email, "Nice job Ric!! R U ready for vacation yet?"

Eight months would elapse before the DHS would make its next visit to the CDC.

On July 14, Sally Titus, DHS Deputy Director for Programs and Services, wrote a letter of response to a legislator who had inquired about DHS's oversight of the CDC. Titus' letter stated in part:

CFI submitted a corrective action plan dated June 18th and has made changes in their management. The corrective action plan is attached. **The Department will**

²⁶ Spriggs-Dixon found CDC staff had not been writing incident reports as required by the licensing standards. CDC administrators told her they were already attempting to correct this deficiency. She did not substantiate the other new complaint, which alleged new teachers were not always verifying whether individuals picking up kids were authorized to do so.

²⁷ This written statement by Spriggs-Dixon was the only record we could find of a DHS employee determining, in 2010, whether any portions of CDC's Corrective Action Plan were acceptable.

²⁸ This language comes from page 11 of Chapter E, Title 12 of the DHS Employees' Manual.

continue to work with the agency to ensure that necessary and sufficient changes are implemented. (emphasis added).

DHS's next visit to the CDC occurred the following spring, when Child Care Licensing Consultant Nate Knepper conducted an eight-hour long licensing visit on March 15, 2011.²⁹ His licensing report stated in part:

The center was placed on a provisional license last year after being issued a full license in 2009. Last year's licensing violations were checked and all of them have been corrected.

... A full license is recommended at this time. There are some issues that still remain, but many of these issues were inherited from the previous director. The current director and her staff have a plan in place to correct these issues and are slowly, but surely getting these issues corrected.

ANALYSIS AND CONCLUSIONS

What was going on between those children was very serious and outside of the norm of normal body exploration that can happen at that age.

— *Renee Larsen, then-Child Care Regulatory Program Manager*

We divide our analysis of these findings into two components:

1. Whether the DHS's decision not to suspend or revoke CDC's license was reasonable.
2. Whether the DHS took reasonable follow-up actions in determining whether CDC actually corrected its deficiencies.

Whether the DHS's decision not to suspend or revoke CDC's child care license was reasonable

The DHS does not often suspend or revoke the licenses of child care centers. Nearly four years have elapsed, the DHS says, since it last suspended or revoked a center's license. The last suspension was in August 2009. The last revocation occurred in June 2009.

Reducing a license to provisional status, on the other hand, has occurred with much greater frequency. The DHS says 198 center licenses were reduced to provisional status at some time in 2010, the year CDC's license was reduced. That figure dropped slightly to 175 in 2011.

As shown by the findings, the issue of whether to suspend or revoke CDC's license was the subject of internal discussions among DHS staff. These discussions were triggered by the licensing consultant's findings surrounding the June 3 incident, particularly because that incident occurred only two weeks after she issued Complaint Report #4, which found several violations and reduced the CDC's license to provisional status.

²⁹ Knepper was hired as a Child Care Licensing Consultant effective on October 1 to fill the position vacated by Spriggs-Dixon's retirement.

What follows is a closer look at four specific deficiencies described in Complaint Report #5 (all three versions). These findings were the catalysts for DHS’s internal discussions about whether to suspend or revoke CDC’s license:

1. The two teachers had not been provided any training for preventing, and responding to, children acting out sexually even though Complaint Report #4 had identified several trainings as required actions.
2. At the time of the June 3 incident, CDC had not acted on the requirement in Complaint Report #4 to identify and remove all visual obstructions from the classrooms. The setting for the June 3 incident was a play area “which was almost entirely enclosed by shelving, a wall, and a kitchen set, with a small entryway on the south end,” according to Complaint Report #5 (all three versions). As noted in the findings, the “visual obstructions” issue had still not been fully addressed on the licensing consultant’s June 21 site visit.
3. The two teachers assigned to the classroom allowed the four boys to be together despite knowing two of the boys had a history of engaging in more mature play when together.
4. CDC staff did not immediately notify the parents of the four children involved in the June 3 incident.

The cumulative significance of CDC’s June 3 deficiencies, coming so close to the previous violations, was enough for Spriggs-Dixon, the Child Care Licensing Consultant at the time, to recommend revoking CDC’s license. In light of that recommendation, Jeff Anderson, then-Chief of the Child Care Services Bureau, advised Division Administrator Rickman that suspension or revocation would have been allowable by policy.

When asked if anything should have been done differently, with the benefit of hindsight, Anderson responded:

I think there should have been more discussion around both [*Complaint Report #4 and Complaint Report #5*]. In hindsight there should have—we should have sat down with the management on both sides, both the field staff side as well as policy side and said “OK, what do we got here? What do we need to do? What is the best decision to make?” And it just didn’t occur.

When asked why he and other managers did not hold more discussions about whether to suspend or revoke CDC’s license, Anderson replied:

I would say, based on working in central office, unfortunately busyness. Busyness. And then the question is, who should push it?

As noted above, Anderson’s view—that a revocation would have been allowable under policy—was submitted to Rickman, the division administrator. Asked where it went from there, Rickman replied:

What I recall is Denise [*Gonzales, then-Manager of the Centralized Service Area*] and I kind of walking through what—just what the different levels of action were, I guess.

I don’t recall ever having a specific conversation about a specific decision. I mean it was more around what Jeff [*Anderson*] had talked about in terms of, “Yep, we can leave them on a provisional, I don’t necessarily see a revocation

being out of line from a policy perspective but not necessarily making a recommendation either direction.”

Notably, Rickman said she did not agree with Spriggs-Dixon’s determination, in Complaint Report #5, that CDC had not taken the visual obstruction issue seriously. Rickman told us:

I don’t necessarily characterize “here’s another place where kids can’t be seen” as a wholesale disregard for the recommendations we made to them before. To some extent this incident occurred when there was a bloody head on the playground, we had staff running to and fro—that doesn’t change the expectation that they had to take some of those walls down and those high shelves and all that. But I don’t necessarily categorize it as an all out just ignoring what was said by the department in the previous recommendations.

Rickman also noted Spriggs-Dixon’s supervisor, Ric Hirst, was not pushing the revocation option.

During our witness interviews there were some references to an imaginary “tipping point” that would help inform the DHS whether to continue a center’s provisional license or to take more severe action in the form of suspension or revocation. It was acknowledged that defining such a “tipping point” with any precision would be difficult. “I don’t know if there is a magic tipping point,” Anderson told us, “and I don’t know how you would come up with that, because every situation’s gonna be so different.”

In the end, Rickman said, the decision was to leave CDC’s license on provisional status and not to pursue a suspension or revocation. Asked for the basis of that decision, Rickman responded:

The nature of the adverse action in balance with the continued work from a facility perspective to straighten things around. So, for example, CFI was taking very firm personnel action from everything that we—we were hearing all kinds of things about it. They were trying to figure out from a management perspective what they were going to do. So we, on balance, we left them on a provisional.

Anderson said he understood that by not pursuing a suspension or revocation, it might appear that the DHS was not holding CDC accountable for the failures surrounding the June 3 incident—particularly because the provisional licensure action was based entirely on Complaint Report #4 and was not connected to Complaint Report #5.

Our interview with Anderson included this exchange about the possible appearance that the DHS did not hold CDC accountable for the failures surrounding the June 3 incident:

Ombudsman investigator: How would you explain that to a parent who had a kid who was involved?

Anderson: That would be a difficult one.

Ombudsman investigator: Give me your best shot.

Anderson: My best shot? That they’re working with the place, working with the facility, to get themselves back in compliance, particularly in the issue of supervision and also that there needs to be training done, we’re trying to get that arranged.... Cause parents don’t like to move their kids if they don’t have to, either.

CONCLUSION

We believe the arguments for and against suspension or revocation both had valid points, in part because the relevant DHS administrative rules do not provide any meaningful guidance for when one of these options is warranted and/or preferable to the others. Given the lack of clarity from DHS's administrative rules, the issue of whether to suspend or revoke CDC's license was an open, debatable question. Reasonable minds could disagree.

After considering this information, we cannot conclude the decision not to pursue a license suspension or revocation, in and of itself, was clearly unreasonable. At the same time, however, it is clear that DHS management did not give sufficient time and attention to this serious matter.

RECOMMENDATIONS

3. The DHS should review its administrative rules and its Employees' Manual regarding revocations, suspensions, and provisional licenses with the goal of providing clearer guidance regarding the types of circumstances where each of these options is warranted.
4. The DHS should amend Iowa Administrative Code rule 441—109.10(10) in a way that makes it clear that incidents in which a child engages in sexual behavior that is clearly age-inappropriate must be reported immediately to the parent.
5. The DHS should amend Iowa Administrative Code rule 441—109.4(2) to require centers to develop and implement written policies ensuring staff training and development for reporting child abuse and age-inappropriate sexual behavior.
6. The DHS should review the "Child Care Centers" section of its Employees' Manual (Chapter E of Title 12; last revised in 2005) and make any necessary modifications, as appropriate, so that the language in Chapter E is consistent with the department's current practices and procedures. This investigation has revealed several inconsistencies between language in Chapter E and DHS's actual practice. Here are two such examples:
 - *Chapter E says:* The licensing supervisor must give approval if a complaint investigation causes a child care consultant to recommend a negative licensing action, such as suspension or revocation (page 12). Similar language also appears on page 16.
Current practice: The manager of the Centralized Service area must also give approval.
 - *Chapter E says:* Letters notifying families about a founded child abuse report involving a center employee are signed by the child care consultant.
Current practice: Such letters are signed by the division administrator.

Whether the DHS took reasonable follow-up actions in determining whether CDC actually corrected its deficiencies

Everyone we interviewed agreed: The decision not to pursue a suspension or revocation of CDC's license made it absolutely critical that the DHS closely monitor the CDC, primarily to ensure that the deficiencies surrounding children's sexual behaviors were corrected in a timely manner.

Renee Larsen, then-Child Care Regulatory Program Manager, offered this explanation:

Provisional is really when there have been serious issues going on impacting children in a center and we lay out certain things that they need to do to address those things. So we really need to stay on top of it, because those are the strategies that we would use to protect children. You want the consultant to go in to really assess and analyze what's going on in the center to make sure that things are better.

In recalling his decision to accept sticking with the provisional licensure action, Jeff Anderson described it as a situation of, "Putting faith and trust in the licensing staff that they were going to monitor, that they were going to stay on top of it, they were going to work with that center to make the needed changes.... See, you put your faith in them that they're doing their job and that the people who supervise them are doing their job to supervise them."

DHS field staff made no visits to the CDC over a critical eight-month span

We are willing to concede that the DHS should only use suspension or revocation in the most dangerous of situations because closing a center can be a significant hardship for many of the effected families. Under this approach, there will be cases—like this one—where the best path is unclear.

Given these considerations, in cases where the DHS considers these options and decides against a suspension or revocation, it becomes **absolutely necessary** that the department stay on top of the situation with regular return visits to determine whether the center is making progress towards correcting its deficiencies.

In this case, DHS's internal emails show several top managers were keenly aware, in July, that DHS's own policy said return visits were "essential" for a center with a provisional license. Unfortunately, that awareness did not get conveyed to the field staff. As our findings pointed out, the DHS made no return visits to the CDC over a crucial eight month period (July 2010-March 2011). That was a critical failure. Incredibly, DHS administrators apparently were not even aware of this failure until it was brought to light by our inquiries.

Rickman confirmed that she expected licensing staff were going to continue to monitor the CDC closely. Our interview then included the following exchange:

Ombudsman investigator: What did you do to see to it that that occurred?

Rickman: I really did not—I did not do any specific follow-up.

Ombudsman investigator: Whose job was that?

Rickman: I can say certainly to some extent it was mine. I administer the policy division and I did not do anything specific to make sure that that corrective action plan was being followed up on diligently.

DHS did not timely determine the adequacy of CDC's Corrective Action Plan

As noted in the findings, our investigation found no indication that the DHS approved CDC's Corrective Action Plan in 2010. We asked Jeff Anderson about this and he said, "There should be documentation that someone did that" (approved CDC's corrective action plan). The absence of such documentation, he said, "means we don't know if it was done or not."

Given this, it should not be surprising that CDC's formal responses to four required actions—each involving staff training—were not adequate.³⁰ Moreover, we found no indication that DHS administrators were even aware, before our investigation, that any of CDC's written responses were inadequate.

In December 2011, we sent an inquiry to the DHS which asked for clarification regarding CDC's responses to four of the required actions from Complaint Report #4. The DHS later acknowledged that in order to answer our inquiries, department staff had to request additional information from CDC. On January 9, 2012, the DHS received that additional information.

Following is our summary of the four above-mentioned required actions from Complaint Report #4, along with CDC's June 2010 written responses and DHS's subsequent 2012 responses:

1. *DHS Required Action #1*: “Administrators shall take immediate steps to schedule Second Step training for all staff that have not had it, including themselves. This training addresses children’s social and emotional development.”

CDC June 2010 Response: “Second Step training will be provided for all CDC staff in July.”

DHS 2012 Response: CDC reported that Second Step training was taken in June 2011 (a year later) by four lead teachers.

Ombudsman’s Comment: It appears CDC partially complied with this required action. The required training occurred a year later, but it is unclear whether it was taken by all staff who had not done so, including administrators.

2. *DHS Required Action #2*: “I am also requiring that all staff, including administrators, receive training in Positive Behavior Supports [PBS]. It is critical that administrators know the difference between activity that is ‘just kids being kids’, and activity that goes beyond simply curiosity play.”

CDC June 2010 Response: “No one has had Positive Behavior Supports training yet as it is a relatively new class.... We are working on arranging for Positive Behavior Supports training for CDC staff at CDC since that would work better than staff trying to arrange on their own ... to attend a class.”

DHS 2012 Response: CDC reported that “all of the lead teaching staff and 3 assistant teachers have had Positive Behavior Supports Training.”

Ombudsman’s Comment: It is unclear whether CDC fully complied with this required action. The information from the DHS does not indicate whether **all** staff received PBS training.

3. *DHS Required Action #3*: “All staff will need to receive training in the Creative Curriculum, which helps staff to structure the program according to developmental goals and objectives.”

³⁰ It is worth noting that Complaint Report #4 specifically stated, “The written plan of correction should include documentation that staff have completed the required training as set forth in this report. It should also include copies of revised policies. The licensing consultant should receive the written notice of corrections no later than June 18, 2010. **If training has not been taken by that time, scheduled times for training should be included.**” (emphasis added).

CDC June 2010 Response: “Classes for the near future appear to all be full.”

DHS 2012 Response: CDC reported that six “Current Lead Teachers have completed all of the components of Creative Curriculum” and five others “have completed the CC Gold online reporting training.” In addition, assistant teachers “have had multiple hours of creative curriculum training” and CDC “continues to send teachers as the trainings become available.”

Ombudsman’s Comment: It appears CDC has fully complied with this required action, although the DHS did not confirm this before our December 2011 inquiry.

4. DHS Required Action #4: “Since all of the issues regarding transparency are related to business practices and ethics, I am requiring center administrators to complete training in the business course provided by United Way Consultant Stacey Walters. If she is not available for training, administrators will need to research and schedule another leadership course that provides an ethics component.”

CDC June 2010 Response: CDC’s Corrective Action Plan acknowledged this required action but provided no further information.

DHS 2012 Response: The center’s two administrators were terminated by CDC in June 2010. “The current Center Director ... has 20 year [sic] of early childhood administration experience and has been enrolled in the National Louis University McCormick Center for Early Childhood Leadership Aim 4 Excellence national Directors Credential. She is scheduled for completion in February of 2012. The cohort leader for this class is Stacey Walter. Included in this credential is ethics education and in-depth program administration education. CFI also completed the PAS assessment (Program Administration Scale), measuring early childhood leadership and management and the Work Environment Profile, measuring staff perceptions of the organizational climate.”

Ombudsman’s Comment: It appears CDC is in general compliance with this required action, although the DHS did not confirm this before our December 2011 inquiry.

In addition, Complaint Report #5 (all versions)—which focused on the June 3 incident and was not submitted to CDC until late July, more than a month after the DHS had received CDC’s Corrective Action Plan—included the following additional requirement:

And because this new incident makes it clear that there has been no staff training with regard to the issue of children acting out sexually, this should also be addressed through an in-service immediately. The schedule for this should be included.

According to the DHS, CDC said it provided that required training in 2010, but the DHS did not receive this confirmation until it responded to our December 2011 inquiry. According to the DHS, CDC claimed the acting center director met with all then-current employees in May 2010 to review strategies for dealing with sexual behaviors by children at the CDC.

It is worth noting, however, that this claim by CDC is in conflict with the findings in each version of Complaint Report #5. That report, which focused on the circumstances surrounding the June 3 incident involving the four boys, stated in part:

There is reason to believe that little or no staff training occurred after those [spring 2010] incidents in order to prevent such occurrences in the future. Indeed, both staff stated that they were unaware of any similar events that had occurred in

the center, and they stated that they had not received any training on prevention, nor have they been told what to do if such an incident occurred.

Given this information, it is unclear whether CDC actually complied with this particular requirement. It appears the DHS accepted CDC's claim about the May 2010 trainings by the acting CDC director. We found no indication that the DHS realized CDC's claim is in conflict with DHS's Complaint Report #5. However, due to the passage of time, we have chosen not to pursue this issue further with the DHS.

“It wasn't one of our shining moments”

Notably, according to the DHS, the new licensing consultant made at least seven monitoring visits to the CDC in 2011 and 2012, and found the CDC to be in “substantial compliance” with the licensing standards. It is perhaps fortuitous that no further sexual incidents have been reported at CDC since 2010. The CDC somehow righted the ship—the sexual behaviors apparently stopped—but this was in spite of the DHS dropping the ball. “It would be hard for me to say that we were totally on top of it,” acknowledged Division Administrator Rickman, “when we did not have specific visits there in a fairly long amount of time.”

“It wasn't one of our shining moments,” she added.

Anderson agreed DHS's follow-up efforts were lacking. “Why?” he asked. “I can't answer that question obviously, but that should have occurred. There should have been more follow-up.”

In the complaints to our office, it was alleged that the DHS and CFI had a cozy relationship and that explained why the DHS did not take more severe enforcement action against CDC. Asked for her reaction to that allegation, Rickman said:

I have a relationship with most of the agency providers cause I think conversations are important to make our system better. But to think that we wouldn't take action against an agency because of that relationship just is not accurate.

Anderson had a similar reaction:

This was just a very difficult case all around, for numerous reasons. And this case was in some ways one of the more difficult ones that they've probably handled in a number of years.... I think that people were doing the best they could, I don't think there was any malice or any type of feelings that “let's sweep this under the rug.”

Rickman noted the department was still undergoing a significant reorganization in early 2010. Some employees had been assigned to new positions and new duties. This included Rickman and Gonzales, both of whom took on new managerial roles in DHS's central office in January 2010. “When this case came around, we—from an organizational perspective—were just in flux,” Rickman said. “And trying to figure out where we stood with that.”

“This was just kind of the first big case that involved two different divisions that had just been put into this new configuration,” Rickman explained. “So it was just trying to figure out where all the pieces were, really.”

“I certainly think we were learning on the run,” she added.

While acknowledging the DHS did not handle the case well, Rickman said “it was for no other

reason than just trying to figure things out and the unique circumstances of everybody just being so new. It still isn't good, you know, to say that we were not diligent in following up on the corrective action plan."

Rickman said her division held a "post audit" of the CDC case to discuss what did not go well and how to do a better job in the future. "I think we're doing in general a much better job across the board with facilities, with child care centers," Rickman said. "You would see a completely different response today than you saw back then."

CONCLUSION

The DHS's failure to visit CDC over a critical eight-month span was compounded by DHS's simultaneous failure to review CDC's Corrective Action Plan. Based on this, I conclude the DHS did not take reasonable follow-up actions in determining whether CDC actually corrected its deficiencies.

ISSUE #5

Whether DHS's failure to notify parents of all CDC children of the provisional license action was unreasonable, even though in accordance with law

RELEVANT STATUTE

Iowa Code section 237A.8 states:

The administrator, after notice and opportunity for an evidentiary hearing before the department of inspections and appeals, may suspend or revoke a license or certificate of registration issued under this chapter or may reduce a license to a provisional license if the person to whom a license or certificate is issued violates a provision of this chapter or if the person makes false reports regarding the operation of the child care facility to the administrator or a designee of the administrator. **The administrator shall notify the parent, guardian, or legal custodian of each child for whom the person provides child care at the time of action to suspend or revoke a license or certificate of registration.** (emphasis added).

FINDINGS OF FACT

On May 18, Spriggs-Dixon completed her reinvestigation of the sexual behaviors complaint and submitted her report to CDC (Complaint Report #4). According to Complaint Report #4, she found CDC's two administrators and CDC's therapist had ignored reports from staff about a child who had been acting out sexually with other children. Complaint Report #4 also expressed concern that CDC's recent firing of two employees may have been in retaliation for reporting information to the DHS.

Complaint Report #4 stated CDC's license was being reduced to provisional status. The report also imposed a number of "actions required" on CDC (actions needed to correct various violations) and required CDC to submit a written response by June 18.

On June 4, the DHS addressed a letter to all parents, guardians, and legal custodians of children attending CDC. DHS's letter stated in part:

This notification is to inform you that there were seven confirmed reports of child abuse at CFI Child Development Center. The incidents occurred on or about April 15, 2010, at the center, were assessed, founded, and placed on the central registry for child abuse as required by law.³¹ If your child had been involved you would have been contacted during the assessments. Please note that the confirmed reports are subject to appeal. If appeals are successful, the reports could be modified or removed from the central registry. You will be notified if the findings are overturned or modified from appeal.

On June 14, Spriggs-Dixon completed her investigation of the June 3 incident and submitted her report—Complaint Report #5—to her supervisor. Spriggs-Dixon's report found that the sexual behavior in the June 3 incident was extremely age-inappropriate, with numerous references to

³¹ Based on our investigation, we believe the April 15 reference is at least somewhat inaccurate. The incidents that led to six of the founded abuse reports occurred prior to April. We were unable to determine why DHS's letter indicated all of the incidents occurred on or about April 15.

penises being touched, shaken, and sucked. Complaint Report #5 found several licensing-related violations had contributed to the incident.

On July 12, the DHS addressed a letter to all parents, guardians, and legal custodians of children attending CDC. DHS's letter stated there were:

... eight confirmed reports of child abuse, specifically Denial of Critical Care for Lack of Proper Supervision, at the [CDC]. The incidents that occurred on or about June 3, 2010 at the center, were assessed, founded, and placed on the central registry for child abuse as required by law.... Please note that the confirmed reports are subject to appeal. If appeals are successful, the reports could be modified or removed from the central registry. You will be notified if the findings are overturned or modified from appeal.

On July 14, the DHS addressed a letter to parents, guardians, and legal custodians of children attending CDC. DHS's letter was a follow-up to the June 4 letter, which said there had been seven confirmed reports of child abuse regarding incidents that had occurred on April 15. DHS's July 14 letter stated:

This notification is to inform you there were seven confirmed reports of child abuse, specifically Denial of Critical Care for Lack of Proper Supervision, at the [CDC].³² Please note that a notification was sent to you on June 4, 2010 however we did not inform you as to the type of abuse. We apologize for the oversight.

ANALYSIS

While the DHS sent three letters that summer to families of the children attending the CDC, none of those letters made any mention of the fact that the DHS had reduced CDC's license to provisional status due to the findings of Complaint Report #4. Under the statute, the DHS was not obligated to inform parents about the provisional license action.

But under the circumstances, was it reasonable for the DHS not to at least mention the provisional license action in one of the three letters sent to families that summer? When we raised this issue in interviews, nobody argued that the DHS should not have notified families about the provisional license action.

Most noted that under the DHS policy, centers are required to "conspicuously" post the certificate of license, and this would have included the June 8 notice that CDC's license was being reduced to provisional status.

Several witnesses took the position that because the provisional license notice had to be posted conspicuously, that essentially served as notice to families. That may be technically true. However, when you look at the actual notice, we question how realistic it is to expect that families would be regularly monitoring a child care center's bulletin board in the off chance that one day the license might be reduced to provisional status. We made this point to Division Administrator Rickman and she agreed.

³² DHS's July 14 letter to families did not correctly identify the seven confirmed abuse reports. In fact, six of the confirmed reports involved Denial of Critical Care for Lack of Proper Supervision, and one involved Physical Abuse.

CONCLUSION

The families of the CDC received three letters from the DHS in 2010, each providing notice—required by law—of founded child abuse reports involving CDC staff. Under the circumstances, we believe knowing that CDC’s license had been reduced to provisional status would have been at least as important to the families as the child abuse information. As a result, we conclude it was unreasonable for the DHS not to mention the provisional license action in at least one of the letters sent to families that summer.

RECOMMENDATIONS

7. Legislative proposal: Iowa Code chapter 237A should be amended to require the DHS to provide notice to parents whose children attend a facility in which the license is placed on provisional status. This could be accomplished by modifying 237A.8 as follows:

237A.8 Violations — actions against license or registration.

The administrator, after notice and opportunity for an evidentiary hearing before the department of inspections and appeals, may suspend or revoke a license or certificate of registration issued under this chapter or may reduce a license to a provisional license if the person to whom a license or certificate is issued violates a provision of this chapter or if the person makes false reports regarding the operation of the child care facility to the administrator or a designee of the administrator. The administrator shall notify the parent, guardian, or legal custodian of each child for whom the person provides child care at the time of action to suspend or revoke a license or certificate of registration, or to reduce a license to provisional status.

8. The DHS should amend Iowa Administrative Code rule 441—109.4(3)(a) as follows:

109.4(3) Required postings.

- a. Postings are required for the certificate of license, notice of exposure of children to a communicable disease, and notice of actions to deny, suspend, or revoke the center’s license, as well as notice of actions to reduce the center’s license to provisional status, and shall be conspicuously placed at the main entrance to the center. If the center is located in a building used for additional purposes and shares the main entrance to the building, the required postings shall be conspicuously placed in the center in an area that is frequented daily by parents or the public.

ISSUE #6

Whether DHS's actions in editing and/or redacting the original licensing inspection report about the June 3, 2010, incident were inconsistent with policy or based upon improper motivation

RELEVANT POLICY

The DHS Employees' Manual (Chapter E of Title 12) includes a section titled "Complaints" which states in part, "The consultant shall document noncompliance, resolution and correction information on form 470-4067, *Child Care Center Complaint*." A similar instruction is included in the next section, titled "Investigations for Child Abuse Referrals."

Chapter E states in part, "If the complaint is going to result in a negative licensing action, the licensing supervisor must approve the action and send the *Notice of Decision* and the *Child Care Center Complaint*."

The appendix to Chapter E, titled "Child Care Center Appendix," offers additional instructions regarding the information that should be included on the *Child Care Center Complaint* form which contains:

- Facility identifying information,
- The identification of the concern that was alleged and the corresponding licensing rules and laws that are the subject of the inspection,
- A summary of how the complaint was investigated,
- What was found in regard to compliance with licensing rules and laws, and
- What changes occurred or corrections were requested in response to the findings or complaint event.

Chapter E also includes a section titled "Investigations for Child Abuse Referrals." That section states in part:

When it is alleged that child abuse has occurred in a licensed child care center, the child protection worker shall immediately inform the child care consultant. The child protection worker and the child care consultant shall plan a collaborative assessment of the center's actions based upon the known facts of the case.

The child care consultant's participation in the investigation of the alleged abuse shall focus on compliance issues with the child care licensing rules and law. The Department "may inspect records maintained by the center and may inquire into matters concerning these centers and the persons in charge."

... Note that Iowa Code Section 237A.7 does not prohibit the disclosure of information in the licensing file relative to the operation of the facility as long as it does not disclose information identifying individual persons, including children. In this regard, **language in the documentation and summary information should not relate to child abuse in any way, but rather address compliance issues that may be involved.** (emphasis added).

In response to our inquiry, the DHS said the department:

...has not provided any additional standard written guidance to its child care licensing consultants regarding the types of information that should be included and/or types of information that should not be included in a “Child Care Center Complaint” form. Individualized guidance may be provided on specific cases as part of routine supervision.

FINDINGS OF FACT

As part of this investigation we conducted sworn interviews of six individuals who were employed by DHS in 2010 and played key roles in contributing to the DHS’s actions. All six had significant experience with the DHS. None of these witnesses could recall, prior to 2010, a DHS supervisor rewriting a child care consultant’s complaint report. Notably, there were two such instances in this matter in 2010.

Marsha McBee, a 12-year veteran in DHS’s child care licensing bureau, who has spent nine of those years as a support staff for the child care licensing consultants, told us it was common for a supervisor to offer editing suggestions to consultants while they are writing a report. But she could not recall any examples, prior to 2010, of a supervisor “personally” editing such a report. This was shared by JoEllen Spriggs-Dixon, who at the time was preparing to retire after 22 years as a DHS Child Care Licensing Consultant.

Different versions of Complaint Report #4

DHS’s records show the original version of Complaint Report #4 had been reviewed and approved by Assistant Attorney General Tabitha Gardner, before it was mailed to CDC on May 18. Within a few days, however, DHS management was advised by another Assistant Attorney General, Diane Stahle, that the report should be rewritten. In a May 21 email to Spriggs-Dixon and Gonzales, Hirst wrote:

Denise [*Gonzales*] has meet [*sic*] with Attorney Generals office and they are asking that amended report be written. Any discussion or mention of retaliation needs to be deleted. Any reference to employees being fired or dismissed needs to be changed to employees no longer working there. The concern is we not enter into an agencies employment practices. We have no rule base to support that.

This triggered an email chain in which Spriggs-Dixon objected to the decision to rewrite Complaint Report #4, in part because the DHS had already submitted that report to the CDC. Spriggs-Dixon’s opinion was supported by Renee Larsen, then-Child Care Regulatory Program Manager, who wrote a May 24 email arguing that the concerns about possible retaliation belonged in DHS’s report:

The firings are a component of an overall pattern of management that resulted in the abuse of children. As such, I think we could keep the fact that people were fired after talking to DHS in the report and that there was the perception of retaliation in the report. It is reasonable to conclude that reasonable people in similar circumstances would have that perception. Through provisional licensure, the center will have an opportunity to change this atmosphere to avoid revocation.

I understand the concerns about meddling in employment situations, but in this case, I think it is reasonable to do so as it directly ties to the safety of

children. We might face bigger concerns if we revise the report (perception of “protection” of CFI by the public, perception of lack of proper exercise of regulatory authority, etc.)

Spriggs-Dixon and Larsen were overruled. Hirst subsequently rewrote Complaint Report #4, primarily to soften the concerns about possible retaliation. On May 26, Hirst emailed the revised version to Gonzales. “Final draft with Diane Staley’s [*sic*] required changes,” Hirst wrote. “Not sent out.”

On June 3, Gonzales in turn forwarded the revised version to her boss, Vern Armstrong, Administrator, Division of Field Operations. From there, it was unclear what happened to the revised version of Complaint Report #4. Through our investigation, we were unable to find any indication that the DHS ever sent it to CDC.³³

Inexplicably, several DHS managers told us they had assumed the revised version of Complaint Report #4 had been submitted to CDC. “I assumed it had been finalized and sent,” Armstrong stated in an email.

“I probably made the assumption they would pull back the other one,” Jeff Anderson told us.

Wendy Rickman, the division administrator, told us she thought DHS sent the revised version of Complaint Report #4 to CDC and told them to ignore the original version. We asked Rickman to provide us with any records she could find to support her belief. Rickman later told us she was unable to find any such records.

“We made so many goofy mistakes in this process around this case,” Rickman told us. “Would it surprise me if we didn’t send the damn thing? In this particular circumstance nothing would surprise me.”

Although steps were taken to revise Complaint Report #4, we found no evidence that the DHS actually rescinded the original version of this report or submitted the revised version to CDC.

Different versions of Complaint Report #5

The June 3 incident involving the four boys was reported to the DHS on June 4. After completing her investigation, Spriggs-Dixon submitted her report—Complaint Report #5—to her supervisor, Ric Hirst, then-Child Care Licensing Supervisor. Based on interviews of the four boys, Spriggs-Dixon’s report included numerous references to penises being touched, shaken, and sucked.

“Before I send this report to [CDC], I wanted to see if there were any legal or policy issues,” said Spriggs-Dixon’s June 14 email, addressed to Hirst; Gonzales, and Assistant Attorney General Gardner. “Please let me know if this is fine to send. It probably needs to go out soon.”

Spriggs-Dixon’s report included a conditional recommendation: If the June 3 incident resulted in any additional founded child abuse reports against CDC staff, the DHS should begin the process of revoking CDC’s license.³⁴

³³ As of January 24, 2013, DHS’s public licensing file included both versions of Complaint Report #4 – the original version by Spriggs-Dixon (the one that was mailed to CDC on May 18); and the revised version by Hirst (which apparently was not sent to CDC).

³⁴ In fact, the June 3 incident led to eight new confirmed reports of child abuse involving CDC staff, according to DHS’s July 12 letter to parents, guardians, and custodians.

Hirst forwarded Spriggs-Dixon's report to his supervisor, Gonzales. In a June 14 email to Hirst, Gonzales described her concerns about Spriggs-Dixon's report:

JoEllen's report is sooooo detailed – again – I need to ask (do we really need it to be so detailed). I get that the CPW [*child protective worker*] needs to have such a detailed report. But, Licensing?

Also, I am concerned about the final piece of her report- revocation? I thought you did not think this would be the recommendation?

On June 15, Hirst emailed Spriggs-Dixon and asked her to remove her revocation recommendation from Complaint Report #5. Spriggs-Dixon soon thereafter rewrote the report to remove her revocation recommendation, creating a new version—Revised Complaint Report #5.

We found that Spriggs-Dixon put a copy of the new version—Revised Complaint Report #5—into DHS's public licensing file on or about June 17, one week before her June 24 retirement. Later in June, Lisa, whose son was involved in the June 3 incident, obtained a copy of Revised Complaint Report #5 from DHS's public licensing file.³⁵

Around the same time, Hirst told Spriggs-Dixon that the report still contained too many references to the word "penis" and would be subject to further revisions by management. Internal DHS emails show the revisions were done by Hirst at the direction of Gonzales. Hirst, in a June 24 email to Clerk Specialist Marsha McBee, wrote:

It is still detailed more than I would have done but the essence of what happened and the seriousness of the violations needed to remain intact. Feel free to further modify. I do not think Gloria will have a problem with this report as many of the items have been corrected in their response to us.³⁶

The next day, June 25, Hirst submitted his revised version of the report to Gonzales as an email attachment. "Cleaned, sanitized and reformatted," said Hirst's email. "Let me know and we will send it out."

Later on June 25, Gonzales forwarded the attachment to her bosses (Armstrong and Rickman) with a comment, "Please see the attached report that I asked Ric to submit."

According to Rickman, the DHS believes it mailed this version—Final Complaint Report #5—to CDC about a month later, in late July.

When our office examined DHS's public licensing file in late July, it contained only one version of this report—Final Complaint Report #5. Because that version does not include many of the "penis" references that were in the prior versions, anyone reading Final Complaint Report #5 would not necessarily realize the full extent of the children's recounting of what happened during the June 3 incident.

³⁵ Lisa subsequently provided our office with a copy of Revised Complaint Report #5, which allowed our office to compare that version to other versions of the same report.

³⁶ CFI's executive director is Gloria Gray. Hirst's email did not include the last name for "Gloria" and Hirst could not be interviewed as he passed away in 2010. From our investigation, we are unaware of any other individuals named Gloria who were materially involved in this matter.

ANALYSIS

We asked Gonzales to clarify her concerns about the information contained in the original version of Complaint Report #5. Gonzales responded:

As I recall the best I can, there was information in that report that was specific in nature and identified people and exact incidents which in my opinion belong in a child protection investigation which is different than a licensing investigation.

... Licensing reports are public documents and we needed to be cautious that we didn't clearly identify people and acts that should not have been in the licensing file, as I recall.

Policy guidance states that language in the licensing complaint report "should not relate to child abuse in any way, but rather address compliance issues that may be involved." As odd as it may sound, the numerous references to penises being touched, shaken, or sucked did not meet the statutory definition of "child abuse," primarily because no adults were involved in the behaviors that were described in Revised Complaint Report #5 and removed in Final Complaint Report #5.

Wendy Rickman agreed with this observation:

I can't think of a policy base to make that kind of a shift.... I can't think of a specific policy reason why that would be something that folks would latch onto.

This action may have deprived the parents of children attending the CDC from having an accurate understanding of the extent of the behaviors that were involved.

CONCLUSION

Based on this information, we conclude DHS's actions in rewriting Complaint Report #5 were inconsistent with policy in existence at the time.

RECOMMENDATION

9. The DHS should review and clarify or modify its policy regarding the process and the circumstances under which licensing complaint reports may be revised or any portions may be redacted and by whom, including who has final review and approval of such reports, and when such reports are placed in the public files or sent to child care centers.

ISSUE #7

Whether DHS provided consumers with regular informational updates on the Internet, as required by Iowa Code section 237A.25(3)(b), following the founded abuse reports involving CDC

RELEVANT STATUTE

Iowa Code section 237A.25 states:

237A.25 Consumer information.

1. The department shall develop consumer information material to assist parents in selecting a child care provider. In developing the material, the department shall consult with department of human services staff, department of education staff, the state child care advisory council, the Iowa empowerment board, and child care resource and referral services. In addition, the department may consult with other entities at the local, state, and national level.

2. The consumer information material developed by the department for parents and other consumers of child care services shall include but is not limited to all of the following:

- a. A pamphlet or other printed material containing consumer-oriented information on locating a quality child care provider.
- b. Information explaining important considerations a consumer should take into account in selecting a licensed or registered child care provider.
- c. Information explaining how a consumer can identify quality services, including what questions to ask of providers and what a consumer might expect or demand to know before selecting a provider.
- d. An explanation of the applicable laws and regulations written in layperson's terms.
- e. An explanation of what it means for a provider to be licensed, registered, or unregistered.
- f. An explanation of the information considered in registry and record background checks.
- g. Other information deemed relevant to consumers.

3. The department shall implement and publicize an internet page or site that provides all of the following:

- a. The written information developed pursuant to subsections 1 and 2.
- b. **Regular informational updates, including when a child care provider was last subject to a state quality review or inspection and, based upon a final score or review, the results indicating whether the provider passed or failed the review or inspection.** (emphases added).
- c. Capability for a consumer to be able to access information concerning child care providers, such as informational updates, identification of provider location, name, and capacity, and identification of providers participating in the state child care assistance program and those participating in the child care food program, by sorting the information or employing other means that provide the information in a manner that is useful to the consumer. Information regarding provider location shall identify providers located in the vicinity of an address selected by a consumer and provide contact information without listing the specific addresses of the providers.
- d. Other information deemed appropriate by the department.

FINDINGS OF FACT

During our preliminary investigation in 2010, we reviewed DHS's website and tried to find information about the CDC. We were only able to find very limited information about the CDC, such as a list of CDC's rates of charge and hours of operation.

The only regulatory-related information about CDC we could find in 2010 on DHS's website was a webpage indicating CDC's license was issued April 1, 2009, and would expire April 1, 2011. We were unable to find any indication that DHS's website ever noted that CDC's license had been reduced to provisional status from April 1, 2010, to April 1, 2011.

Considering that Iowa Code section 237A.25(3) was adopted in 2003, our November 23, 2010, letter of notice to the DHS included the following question:

In reviewing the websites maintained by DHS, we have found some information about CDC, but we have been unable to find any indication of "regular informational updates" including when CDC was last subject to a state quality review or inspection and the results.

If this information has been on the DHS website, please provide the link. If not, please explain why DHS is not meeting this requirement.

Then-DHS Director Charles Krogmeier's January 13, 2011, response indicated the DHS was not meeting this statutory requirement because of limited resources. His full response stated:

The provision of easily accessed information on individual providers is a component of our information management system called KinderTrack. However, this component has not been phased in to the system. Due to limited resources, the system has been prioritized to first accommodate the child care assistance program with accurate and timely data to ensure families get what they need and providers are compensated without errors. This has been and continues to be the Department's number one priority. KinderTrack has only been up and running for a year and we do find from time to time the need to adjust the system and to make it more user friendly for families and child care providers.

The second phase has been to gather and enter accurate regulatory information for child development homes. Prior to KinderTrack all actual documentation was held in paper files in DHS county or service areas offices. Entering the data in a consistent manner began in earnest when we centralized child care registration the summer of 2010.

At the same time, licensing staff that do the licensure and provide for the inspections of child care centers, have had and continue to use a separate data base. We are looking at how to best bring that information into KinderTrack to make it accessible to the public on-line.

To summarize, ensuring accurate Child Care Assistance information and then getting accurate child development home data entered have been the priorities and are necessary to provide accurate information to the public.

In June 2011, we asked the DHS to elaborate on the nature and scope of the limited resources, as well as DHS's efforts to bring this issue to the attention of policymakers and the General Assembly. A July 29, 2011, written response by Vern Armstrong, DHS's Division of Field Operations Administrator, stated:

DHS has regular meetings with the Legislative Services Agency and caucus staff and occasional meetings with legislators to discuss three areas of the child care program; eligibility for Child Care Assistance, quality, and regulatory.

The child care assistance appropriation is currently estimating an additional need of \$8.5 million in SFY 13 to maintain our current service level without any improved results.

Field staffing levels, who determine eligibility, licensing and registration issues, have also continued to decline over the past three fiscal years.

We inquired again in October 2012. Mr. Armstrong's November 7, 2012, response stated:

Due to other demands on the child care assistance appropriation, a final estimate has not been developed. As existing resources become available, they are redirected to work on these enhancements.

As of November 1, 2012, the most recent child care center licensing reports and license status are available on the DHS website. These can be accessed by an individual searching for a provider. As additional existing resources become available, they will be redirected to work on enhancements, such as adding complaint reports and reports for registered homes.

We subsequently confirmed that DHS's website now includes:

- The March 27, 2012, child care center licensing report concerning CDC.³⁷
- The current status of CDC's license.

Wendy Rickman, Division Administrator for Adult, Children and Family Services, elaborated on DHS's plans in a January 13, 2013, email which stated:

We do have plans to continue to move forward with posting additional child care information to the internet. We have yet to determine the final site due to significant changes that are in process with the DHS web site....

The following link takes the public to the provider search function. Searching for a center will also locate the most recent center visit report completed by regulatory staff: <https://ccmis.dhs.state.ia.us/ClientPortal/ProviderSearch.aspx>

The second step will be to post complaint reports for parents for centers. We plan on doing this within the next six months. Additionally, this site will be used to notify parents of any changes in licensure status and changes that occur in the child care center's quality rating status. Our intent is to have this all completed by July 1st, 2013.

³⁷ Available at this link:

<https://ccmis.dhs.state.ia.us/ClientPortal/SearchDetails.aspx?data=X9bVDn%2fq%2f5G6BpWjBJXmiQTljylEW20>
1. To access the licensing report, go to the lower left hand corner and click on "View Licensing Visit Report."

CONCLUSION

Based on this information, we conclude the DHS has not been providing child care consumers with regular informational updates on the Internet, contrary to Iowa Code section 237A.25(3)(b), concerning CDC and other licensed child care centers.

RECOMMENDATION

10. The DHS should provide our office with confirmation when it has fully developed and implemented the website improvements to comply with Iowa Code section 237A.25(3).

ISSUE #8

Whether DHS took appropriate and timely follow-up action consistent with law, rules, policies, and practices regarding CDC's "Quality Rating" under the system authorized by Iowa Code section 237A.30 following the founded abuse reports involving CDC

RELEVANT STATUTE AND ADMINISTRATIVE RULES

Iowa Code section 237A.30 states:

237A.30 Voluntary child care quality rating system.

1. The department shall work with the community empowerment office of the department of management established in section 28.3 and the state child care advisory council in designing and implementing a voluntary quality rating system for each provider type of child care facility.
2. The criteria utilized for the rating system may include but are not limited to any of the following: facility type; provider staff experience, education, training, and credentials; facility director education and training; an environmental rating score or other direct assessment environmental methodology; national accreditation; **facility history of compliance with law and rules**; child-to-staff ratio; curriculum, including the extent to which the curriculum focuses on the stages of child development and on child outcomes; business practices; staff retention rates; evaluation of staff members and program practices; staff compensation and benefit practices; provider and staff membership in professional early childhood organizations; and parental involvement with the facility.
3. **A facility's quality rating** may be included on the internet webpage and in the consumer information provided by the department pursuant to section 237A.25 and **shall be identified in the child care provider referrals made by child care resource and referral service grantees under section 237A.26.** (emphases added).

Additional clarification is provided in Iowa Administrative Code rule 441—118 (“Child Care Quality Rating System”). Rule 441—118 includes the following preamble:

This chapter establishes rules for the child care quality rating system, which is designed for child care programs that primarily serve children between birth and the age of 12. Participation in the quality rating system is voluntary. The chapter includes application procedures and standards for the quality rating.

Under rule 441—118, centers applying for a Quality Rating System (QRS) rating are assigned a quality rating based on points earned in five categories:

1. Professional development
2. Health and safety
3. Environment
4. Family and community partnerships
5. Leadership and administration

Rule 441—118.8 states:

441—118.8(237A) Adverse actions.

118.8(1) An eligible applicant must be notified of the right to appeal the rating decision in accordance with 441—Chapter 7.

118.8(2) A participant’s quality rating shall be revoked if the facility no longer meets the definition of “eligible applicants.”³⁸

118.8(3) Form 470-4230, Quality Rating Certificate, shall be returned to the department of human services if:

- a. The certificate is revoked;
- b. The certificate is not renewed; or
- c. The provider voluntarily withdraws from the program.

118.8(4) Ratings are effective for 24 months from the date of issuance.

ADDITIONAL CLARIFICATIONS ON DHS’S WEBSITE

DHS’s website describes the QRS as:

... a voluntary child care rating system for child development homes, licensed child care centers and preschools, and child care programs that are operated by school districts.

The QRS was developed:

- to raise the quality of child care in Iowa
- to increase the number of children in high-quality child care settings
- to educate parents about quality in child care³⁹

DHS’s website includes an “FAQ” page⁴⁰ which elaborates:

What Is Iowa's Quality Rating System?

The Quality Rating System (QRS) is a voluntary program that offers providers a guided way to improve the quality of child care they provide.

What Do the Levels Mean?

A provider who achieves Level 1 has met Iowa’s registration or licensing standards. A provider who achieves Level 2 has received additional training and made the first steps toward improving quality. Providers in Levels 3-5 have made significant steps in meeting key indicators of quality in the areas of:

- professional development
- health and safety

³⁸ Rule 441—118 defines “eligible applicants” as “programs meeting the definition of ‘child care facility’ or programs operating under the authority of an accredited school district or nonpublic school.” “Child care facility” is defined as “a licensed child care center, a preschool, or a registered child development home.”

³⁹This information is available at <http://www.dhs.state.ia.us/iqrs/>.

⁴⁰ Available at <http://www.dhs.state.ia.us/iqrs/faqs/index.html>

- environment
- family and community partnership
- leadership and administration

DHS’s website also says providers who participate in QRS “can receive onsite technical assistance as they go through the steps needed to improve their quality of care.” In addition, the QRS program offers “achievement bonuses” to participating providers. DHS’s website includes the following table.⁴¹

Quality Rating System Achievement Bonus Schedule For Licensed Child Care Centers				
QRS Level	Center licensed to care for up to 25 children	Center licensed to care for 26-50 children	Center licensed to care for 51-100 children	Center licensed to care for more than 100 children
2	\$400	\$800	\$1200	\$1600
3	\$600	\$1200	\$1800	\$2400
4	\$800	\$1600	\$2400	\$3200
5	\$1000	\$2000	\$3000	\$4000

According to DHS’s website:

- Achievement bonuses will be paid each time the rating is re-determined or renewed. A quality rating level is in effect for two years.
- Programs that do not increase their level at re-application will receive half the bonus amount listed above in the bonus chart.

A DHS report stated in part:

- As of July 2010, over 1,300 providers are participating with the majority rated a two-star program. 30.2% of all child care centers and 14.6% of all child care homes voluntarily worked toward and received a QRS rating.
- In SFY 2010, 85.9% of participating child care providers achieved a QRS rating of 2 or higher.⁴²

FINDINGS OF FACT

According to the DHS, the CDC first received a QRS rating in March 2009. CDC’s initial QRS rating was 4 and it has remained at that level to the present time, even during the one-year period when CDC’s license was reduced to provisional status.

⁴¹ Available at <http://www.dhs.state.ia.us/iqrs/faqs/index.html>

⁴² This information is on page 65 of the document available at <http://www.dhs.state.ia.us/docs/2012-Offer-401-HHS-005-Child-Care-Narrative.pdf>.

According to the DHS, the QRS rating is a “point in time” snapshot of how a center is performing when the application is made. In the case of CDC, a legislator asked the DHS, “How can a center with 7 founded child abuse⁴³ and provisional license be listed with 4 stars in the QRS webpage on the DHS website?”

Deputy Director Sally Titus’ July 14 letter of response stated in part:

As you are aware, the Quality Rating system is a voluntary system and has been developed to support child care providers to improve their services. It also helps distinguish those providers seeking to provide quality services. **The rating received is a point in time.** Programs submit documentation to verify that they meet specific criteria at the time of their application, the information is reviewed, and the rating is determined. (emphasis added).

We are able to revoke a rating only if a child care provider’s license or registration is revoked or surrendered. The QRS oversight team composed of representatives from DHS, Public Health, Empowerment, Education, Providers and Iowa State Extension made this decision at the inception of QRS. There are a variety of reasons that licensed centers receive provisional licenses, and the team felt that it was not appropriate to downgrade a QRS rating based on a change in licensing status other than revocation. (emphasis added).

In response to our inquiry, the DHS confirmed that if the CDC had applied for a QRS rating while its license was on provisional status, it would have received a QRS rating of 1; and its rating would have remained at 1 for two years.

Because the CDC has had a QRS rating of 4, and is licensed to care for more than 100 children, the center has received two “achievement bonuses” of \$3,200 (to be paid each time the rating is renewed, which occurs once every two years).

ANALYSIS

The core purpose of the QRS program is to help parents find quality child care providers for their children. But this case shows that the current system can sometimes be both misleading and unhelpful to the parents that the QRS program is supposed to help.

In the case of CDC, a Des Moines-based parent seeking quality child care services between April 2010 and April 2011 would have learned that the CDC had a QRS rating of 4, the second highest rating possible. Unless that parent somehow obtained and reviewed Complaint Reports #4 and #5, that parent likely would not have been aware that the facility’s license had been reduced to provisional status following incidents involving sexual behavior among children at the CDC.

Moreover, because the DHS cannot publicly release information about founded child abuse reports, it is extremely doubtful that such a parent would have learned about the 15 founded child abuse reports involving CDC staff over a period of a few months.

Nothing in the statute prevents the DHS from contemporaneously reducing a center’s QRS rating in connection with significant problems. In fact, Iowa Code section 237A.30 provides that the criteria utilized for the rating system may include “facility history of compliance with law and rules.”

⁴³ The legislator’s inquiry occurred before DHS’s July 12 letter to parents which explained that there were eight additional founded child abuse reports.

Compliance is not static; it can ebb and flow over time. For this reason, it makes sense to design the QRS system to be flexible, so that it can respond in real time to a center's compliance and/or non-compliance, as the statute suggests.

We asked the DHS about this issue and received the following response:

QRS oversight felt that the best approach was to award and encourage programs for the level of quality at which they are currently operating, rather than penalizing them for issues they may have had with compliance in the past. Using previous compliance history in determining a current QRS rating could be seen as punitive to programs that may have struggled in the past, but are working to improve their quality. A QRS rating verifies that, at the time of application, the program provided appropriate documentation to support the rating they receive.

DHS's desire to reward good behavior is perfectly reasonable. However, we believe the reluctance to adjust QRS ratings for non-compliance is mistaken and can in some cases mislead the very families that the program was designed to help.

Under Iowa Administrative Code rule 441—118.5, centers are assigned a rating level based on the number of points earned in five specified categories. There is no mechanism by which a center can lose points for non-compliance with the licensure requirements. Similarly, there is no mechanism for a center to lose points when its license is suspended or reduced to provisional status.

We asked the DHS whether it would be willing to consider adopting a new mechanism in which centers can lose points for non-compliance with certain licensure requirements and/or when its license is suspended or reduced to provisional status. DHS's response stated:

QRS is not structured such that points are recalculated during the certification period. QRS rules were revised in 2010; during the public comment period for that revision, no comments were received regarding re-evaluating programs during their certification period. QRS oversight monitors trends and issues on an on-going basis and factors these in when making recommendations for rule revisions.

Perhaps most importantly, we were unable to find any information directed to consumers which explains, or even suggests, that the QRS ratings represent a "point in time" assessment. Without such an explanation, we are concerned that consumers who review QRS-related information on DHS's website may not realize that a rating represents an assessment of how a facility was performing at the time it applied for a QRS rating, and more importantly, that a QRS rating is not necessarily an indication of how the facility has been performing in recent months.

CONCLUSION

DHS did not take appropriate and timely follow-up action consistent with law regarding CDC's "Quality Rating" under the system authorized by Iowa Code section 237A.30. The QRS program has many good features, but improvements must be made to this rating system to achieve its intended purposes to improve the quality of child care in Iowa and to educate parents about the quality of care by providers.

RECOMMENDATIONS

11. The DHS should remove the "point in time" assessment paradigm for the QRS program and replace it with a system which allows for adjustments to be made contemporaneously

with significant instances of non-compliance. For example, the DHS could adjust the QRS program so that a center, in addition to earning points in various categories, can also lose points in various categories.

12. Until or unless Recommendation 11 is implemented, the DHS should take immediate action to ensure that families who receive QRS referrals are advised that the ratings represent a “point in time” assessment and may not reflect instances of non-compliance with law and rules that have occurred since the center’s current rating was determined.

PROVISIONAL LICENSE AND DUE PROCESS REQUIREMENTS

During our investigation we discovered that the DHS's decision to downgrade the CDC's license to "provisional" status was done without first giving the CDC notice of an opportunity for a hearing. The DHS informed us such notice was not required whenever it reduces a license to a provisional license. We disagree.

Iowa Code section 237A.8, states in relevant part the following:

237A.8 Violations – actions against license or registration

The administrator, after notice and opportunity for an evidentiary hearing before the department of inspections and appeals, may suspend or revoke a license or certificate of registration issue under this chapter **or may reduce a license to a provisional license**.... (emphasis added).

A plain reading of this statute leads us to conclude it requires "notice and opportunity for an evidentiary hearing" not only when the DHS seeks to suspend or revoke a license, but also when it wants to reduce a license to a provisional license. We believe the phrase "after notice and opportunity for an evidentiary hearing" clearly applies to both the ensuing options to suspend or revoke a license or certificate of registration, or to reduce a license to a provisional license.

Our opinion is supported by a review of relevant legislative history. Iowa Code sections 237A.2(3) and 237A.8 were both amended in 1999 to allow the DHS the option to reduce a license to a provisional license. Prior to that, the DHS could issue a provisional license, but could not reduce a license to a provisional one. Section 237A.2(3) grants the DHS administrator the authority to reduce a license to a provisional status, but does not speak to any accompanying due process procedure. If the Iowa legislature had intended to grant the DHS administrator the authority to reduce licenses without a notice and hearing, it could have done that by simply amending the language under section 237A.2(3) without also amending section 237A.8 to add "or may reduce a license to a provisional license."

Related to this, the section heading was also amended in 1999 from "Suspension and revocation" to "Violations – actions against license or registration," in conformity with the intended change.

In addition, we believe the act of reducing a license to a provisional license is adverse action that should trigger due process proceedings under the law. The practical effect of a provisional license is that a child care center may only operate under the license for one year rather than the two years that accompany a full license. The center also falls under the stigma that it acted in some way contrary to the laws and rules that govern its operations. Notice and an opportunity for an evidentiary hearing should be allowed for a center to challenge the status of its license.

We note the DHS made no changes to its administrative rule that grants a hearing for a denied, suspended, or revoked license after the 1999 statutory amendments. Consequently, the existing rule under Iowa Administrative Code rule 441—109.2(6) still only allows a hearing when a license is denied, suspended, or revoked. While the current practice by the DHS is consistent with its administrative rules, it is our opinion that the DHS rule and practice do not comply with Iowa Code requirement for notice and opportunity for a hearing also to be given when a license is reduced to a provisional license.

RECOMMENDATION

13. The DHS should amend its administrative rules and practices to provide notice and opportunity for a hearing when it takes action to reduce a license to a provisional license under Iowa Code section 237A.8.

DEPARTMENT OF HUMAN SERVICES' REPLY



Iowa Department of Human Services

Terry E. Branstad
Governor

Kim Reynolds
Lt. Governor

Charles M. Palmer
Director

July 31, 2013

Ms. Ruth H. Cooperrider
Citizens' Aide/Ombudsman
Ola Babcock Miller Building
1112 East Grand Avenue
Des Moines, Iowa 50319
L O C A L

Dear Ms. Cooperrider:

Thank you for the opportunity to respond to your draft report. On June 20, 2013, the DHS received a draft report issued by the office of the Citizen's Aide/Ombudsman (CAO). The report outlined the findings of a three-year investigation into three complaints received in 2010 regarding the DHS oversight of the Child Development Center (CDC), a licensed child care center owned and operated by Children and Families of Iowa.

Beginning in March 2010, the department has fully cooperated with the CAO with its questions and investigations into our review of complaints and oversight of the Children and Families of Iowa licensed child care center. The CAO provided a preliminary report to the department in November 2010 and requested extensive documentation on several different occasions as it conducted its investigation. The department has provided hundreds of documents, emails, and hours of face-to-face conversation to provide a transparent accounting of the events.

Findings

The draft CAO report identifies we were "generally cooperative in responding to our requests for information," however, it goes on to say the department did not provide full access to nine emails because they were fully or partially redacted. Appropriately the report identifies our rationale for not providing full access to this information. We would only re-emphasize these emails were attorney client communications regarding matters outside the scope of the investigation. We did, in fact, waive attorney client privilege on issues relating to the investigation and the CAO received a number of unredacted emails containing attorney client communications. We maintain we provided all information relevant to your investigation.

Secondly, we appreciate the challenge in identifying and summarizing key information in a report such as this, however, we believe the selective use of quotes by Wendy Rickman, Division Administrator of Adult, Children and Family Services to support your findings did not reflect the full context of her discussion of rationale for actions or decisions on CAO recommendations. Finally, we would note that your stated purpose is to render objective reports. [141 Iowa Admin. Code § 1.1]. We do not believe the title you have assigned to your report meets that criterion.

We believe we made the correct decision not to revoke the Child Development Center's child care license and your investigation did not find this decision "clearly unreasonable". Your November 2010 preliminary report and the final draft report did identify several areas of non-compliance with policy and procedures. We acknowledged and addressed those by taking corrective action. Where we did not concur, we have provided our rationale.

We are responsible for assuring that minimum standards for the health and safety of children are being met by the licensed child care centers. We take this responsibility seriously. Our first and foremost responsibility is child safety. In addition to this we must also be able to assure parents the care their children receive is appropriate and we must respect the complexities child care centers experience in managing their business. We use a very deliberate approach in fulfilling these responsibilities:

- We are transparent about our expectations for child care centers.
- We directly engage providers in all aspects of the licensing and monitoring process.
- We use a graduated approach in our regulation of child care centers, moving from joint problem solving to pursuing suspension or revocation of center licenses if issues are not resolved.

Comments on Specific Recommendations

1. The DHS should amend its administrative rules and Employees' Manual to reflect the new procedures described above. (The draft report outlined six procedural issues in their determinations)

Answer: The specifics outlined in the procedures above will be addressed in the recommendations listed below.

2. The DHS should consider whether it would be appropriate to provide a follow up communication to then-CDC parents to clarify the types of abuse incidents that occurred at CDC in spring 2010.

Answer: We do not believe there is any purpose or value of such notification because these child abuse complaints occurred three years ago and we believe the two prior notifications were sufficient in assuring the parents were aware of the allegations.

3. The DHS should review its administrative rules and its Employees' Manual regarding revocations, suspensions, and provisional licenses with the goal of providing clearer guidance regarding the types of circumstances where each of these options is warranted.

Answer: The department has established a clear process for any provisional license recommendation regarding child care centers that outlines the process from the child care consultant, to licensing supervisor, to all related stakeholders. This tool was implemented in 2012 with staff training. The tool is currently utilized by field staff and central office administrators.

4. The DHS should amend Iowa Administrative Code rule 441-109.10(10) in a way that makes it clear that incidents in which a child engages in sexual behavior that is clearly age inappropriate must be reported immediately to the parent.

Answer: The department will amend Chapter 109.10(10) to require child care centers to complete a critical incident report when inappropriate sexually acting out behavior occurs. This will ensure centers will notify the child's parents immediately of the incident. The rule will be noticed September 4, 2013.

5. The DHS should amend rule 441-109.4(2) to require centers to develop and implement written policies ensuring staff training and development for reporting child abuse and age-inappropriate sexual behavior.

Answer: We do not believe it is necessary to amend this rule because:

- Centers are currently required to directly discuss with new staff methods of identifying and reporting suspected child abuse and neglect within thirty days of employment per the requirements of 441-109.4(2).
- All mandatory reporters must receive training based on approved curricula by the Department of Public Health. The current mandatory reporter training includes a section on sexual abuse identification and reporting. Mandatory reporters by law must complete re-training every five years.
- During licensing visits, licensing consultants verify adherence with these policies.

When combined with the rule change outlined above regarding critical incident reporting, we believe this concern has been appropriately addressed.

6. The DHS should review the "Child Care Centers" section of its Employees' Manual (Chapter E of Title 12; last revised in 2005) and make any necessary modifications, as appropriate, so that the language in Chapter E is consistent with the department's current practices and procedures. This investigation has revealed several inconsistencies between language in Chapter E and DHS's actual practice. Here are two such examples:

- Chapter E says: The licensing supervisor must give approval if a complaint investigation causes a child care consultant to recommend a negative licensing action, such as suspension or revocation (page 12). Similar language also appears on page 1.
- Current practice: The manager of the Centralized Service area must also give approval.
- Chapter E says: Letters notifying families about a founded child abuse report involving a center employee are signed by the child care consultant.
- Current practice: Such letters are signed by the division administrator.

Answer: In 2012, the department implemented a parent notification guide to assure accurate notification when a founded abuse occurred in a child care setting. All licensing consultants and central office administrators were trained. Although it has been in place, it will be added to the Employees' Manual in August, 2013.

7. Legislative proposal: Iowa Code Chapter 237A should be amended to require the DHS to provide notice to parents whose children attend a facility in which the license is placed on provisional status. This could be accomplished by modifying section 237A.8 as follows:

237A.8 Violations-actions against license or registration.

The administrator, after notice and opportunity for an evidentiary hearing before the Department of Inspections and Appeals, may suspend or revoke a license or certificate of registration issued under this Chapter or may reduce a license to a provisional license if the person to whom a license or certificate is issued violates a provision of this Chapter or if the person makes false reports regarding the operation of the child care facility to the administrator or a designee of the administrator. The administrator shall notify the parent, guardian, or legal custodian of each child for whom the person provides child care at the time of action to suspend or revoke a license or certificate of registration, or to reduce a license to provisional status.

Answer: The department believes parents should be informed of critical incidents regarding their children while in the care of a center and is modifying its administrative rule 441-109.10(10) to assure appropriate notice is mandated.

The department does not, however, support the CAO recommendation that the department should notify parents when a center moves to provisional status. Enactment of such a policy has significant implications for the construct of licensure status and would have significant implications for many other providers licensed by the department. Provisional licensure is designed to enable a provider to maintain a license while working

to correct deficiencies that are not so far out of compliance with the basic health and safety standards to warrant an adverse action by the department. Generally, adverse actions are taken when there is a significant or immediate threat to the health and safety of individuals served by the entity.

On November, 7, 2012, we provided the following explanation regarding this same recommendation as it pertained to child care licensure.

"A provisional license is not considered adverse action. Your question starts with the premise that a provisional license is no longer a valid license. The Department would disagree with that interpretation of Iowa Code 237A.2(2)(b). The code provision you cite concerns the length of time a license is valid rather than the validity of a particular class of license. Generally, a child care license is valid for 24 months. However, if a license is reduced to provisional, the length of time it is valid is limited to no more than one year. Iowa Code 237A.2(2)(b). The license is still valid when it is on provisional status - it just doesn't continue for the same length of time. If the Code were interpreted to say that a provisional license is no longer valid, the protections provided by Chapter 237A would no longer apply to centers operating with a provisional license. The Department, the local board of health and the fire marshal can only inspect licensed facilities. Iowa Code 237A.4; 237A.2(3). Personnel requirements are only applicable to licensed facilities. Iowa Code 237A.5. And, most importantly, a facility cannot care for children unless it is licensed. Iowa Code 237A.2(1). Centers with provisional licenses continue to operate as licensed facilities and are subject to all of the requirements of Chapter 237A.

You ask what kind of action a provisional license is if not adverse. A provisional license is a status that allows the facility to continue to operate while the center comes into full compliance with regulatory standards. Pursuant to DHS rules, a provisional license will only be utilized when the Department approves the course of action to be taken to bring the center into compliance. 441 IAC 109.2(3)(b). Because there must be agreement on the corrective action to be taken, there is no adverse action."

The position outlined above does not mean we do not take the issuance of a provisional license seriously. Currently, the department does require centers to prominently post their provisional license which gives parents the opportunity to know about the voluntary corrective action planning the center has agreed to in order to address violations. This expectation combined with the rule change outlined below (question eight), appropriately addresses the issue of parent notice.

8. The DHS should amend Iowa Administrative Code rule 441-109.4(3)(a) as follows:

109.4(3) Required postings.

a. Postings are required for the certificate of license, notice of exposure of children to a communicable disease, and notice of actions to deny, suspend, or revoke the center's license, as well as notice of actions to reduce the center's license to provisional status, and shall be conspicuously placed at the main entrance to the center. If the center is located in a building used for additional purposes, and shares the main entrance to the building, the required postings shall be conspicuously placed in the center in an area that is frequented daily by parents or the public.

Answer: We accept this recommendation and the rule will be noticed on September 4, 2013.

9. The DHS should review and clarify or modify its policy regarding the process and the circumstances under which licensing complaint reports may be revised or any portions may be redacted and, by whom, including who has final review and approval of such reports, and when such reports are placed in the public files or sent to child care centers.

Answer: The department is responsible to assure that all work products, including licensing complaint reports, are objective, accurate, based on documentation, and when applicable, meet state and federal law. We do not consider that any single worker is solely responsible for a work product. Line staff often write reports with the majority undergoing supervisory and/or administrative review as a routine matter of course. This process is designed to assure that our work products are accurate, complete, objective and fully documented. In addition, we believe supervisory and administrative review is essential to ensure consistency across service areas, department divisions and the organization as a whole. We have reviewed our policy and believe this is clear.

10. The DHS should provide our office with confirmation when it has fully developed and implemented the website improvements to comply with Iowa Code section 237A.25(3).

Answer: The DHS is very invested in giving parents and others as much information as possible to improve their ability to choose and monitor their child care center.

The following lists our compliance with Iowa Code section 237A.25(3) :

- The most recent center licensing reports are posted on the DHS Website <http://www.state.ia.us> and are available to parents for review.

- Child Care Resource and Referral Centers and their individual websites, are contractually responsible for addressing the majority of the mandates in 237A.25(1)(2).
- In September 2013, future regulatory reports regarding registered home compliance visits will be posted to the same site.
- In September, 2013 complaint reports for child care centers and registered homes will be posted.

11. The DHS should remove the "point in time" assessment paradigm for the QRS program and replace it with a system which allows for adjustments to be made contemporaneously with significant instances of non-compliance. For example, the DHS could adjust the QRS program so that a center, in addition to earning points in various categories, can also lose points in various categories.

Answer: In the 2013 legislative session, SF446 directed the department to conduct a review of the QRS system. We will be contracting with a nationally recognized entity to perform the evaluation. Included in the final report will be specific recommendations regarding this issue. The report will be forwarded to the Legislature in December 2013.

12. Until or unless Recommendation 11 is implemented, the DHS should take immediate action to ensure that families who receive QRS referrals are advised that the ratings represent a "point in time" assessment and may not reflect instances of non-compliance with law and rules that have occurred since the center's current rating was determined.

Answer: In early August, the DHS website will add a statement on the QRS page notifying parents the QRS status of a center may not reflect minor infractions the center is working on through a mutually agreed upon corrective action plan. We will include a statement that centers are required to prominently post provisional licenses, and we will encourage parents to discuss the licensing status of their center with center staff and administrators.

13. The DHS should amend its administrative rules and practices to provide notice and opportunity for a hearing when it takes action to reduce a license to a provisional license under Iowa Code section 237A.8.

Answer: For the reasons listed above (answer 7), the department will not pursue this specific rule and practice change. The graduated regulatory approach with providers has been quite successful. The mutually agreed upon corrective action plan process has been well received and provides an important step to ensure the health and safety of the children attending child care centers. Under a provisional license the basic business of the

Letter to Ruth H. Cooperrider
Re: Ombudsman's Investigation Report
Page 8

center is maintained while issues are addressed. As a provisional determination is not an adverse action, we are unable to comply with this recommendation. We believe, however, the course of action outlined in the responses above appropriately address the issues outlined in the draft CAO report including this particular concern.

We appreciate the opportunity to provide our comments especially around the recommendations. We are committed to providing effective oversight of the child care centers and to have policies and processes in place that enable us to assure that children are safe, parents are informed, and providers are treated fairly. We will continue to work collaboratively with you to achieve these goals.

Sincerely,

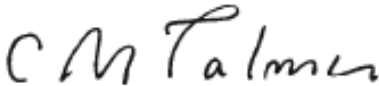

Charles M. Palmer
Director

CMP/WR

**ADDITIONAL INFORMATION REQUESTED
BY THE OMBUDSMAN**

STATE OF IOWA



Telephone: (515) 281-3592
Toll Free: 1-888-426-6283
TTY: (515) 242-5065
Fax: (515) 242-6007
E-mail: ombudsman@legis.iowa.gov
Website: <http://legis.iowa.gov/ombudsman>

RUTH H. COOPERRIDER
OMBUDSMAN

OFFICE OF OMBUDSMAN
OLA BABCOCK MILLER BUILDING
1112 EAST GRAND AVENUE
DES MOINES, IOWA 50319

August 9, 2013

Charles M. Palmer, Director
Iowa Department of Human Services
1305 E. Walnut Street
Des Moines, Iowa 50319
LOCAL MAIL

Subject: Follow-Up Regarding Ombudsman's Investigative Report

Dear Director Palmer:

Thank you for your July 31, 2013, letter of response to my investigative report regarding the Department of Human Services' (DHS) oversight of a licensed child care center owned and operated by Children and Families of Iowa.

I have decided to publish this report. When I do so, your written reply will be appended to and published with the report. I may add some comments to your reply in the report.

Before publication of the report, I am requesting the following additional information.

Public Release of Report Information

It is my belief the report does not contain any information confidential by law, since the information taken from or related to DHS records are or were available to members of the public. At this time I plan to release the report without any redactions.

If the DHS believes my report discloses any information required to be kept confidential by law, I ask you to inform me 1) the specific language and parts of the report that must be kept confidential, and 2) the specific legal basis for each part to be kept confidential.

I request that any confidentiality objection and explanation be provided to me by Friday, August 23. If there is disagreement, I will follow up with you before the report's release.

Request for Additional Information

Your letter includes responses to the 13 recommendations in my report. To help me and my staff better understand your responses, I request the following additional information:

1. The procedures established and the tool implemented in 2012 regarding provisional license recommendations, referenced in your response to recommendation #3.
2. The proposed draft amendment language to Iowa Administrative Code rule 441-109.10(10), referenced in your response to recommendation #4.
3. The "parent notification guide" referenced in your response to recommendation #6.
4. The proposed draft amendment language to Iowa Administrative Code rule 441-109.4(3), referenced in your response to recommendation #8.
5. The statement that will be added to the QRS website, referenced in your response to recommendation #12.

Additionally, I am requesting that you provide a copy of my full report (after publication) to the entity contracted by the DHS to evaluate the QRS program, as provided in SF446.

Thank you and your staff again for your time and cooperation in this investigation.

Sincerely,



Ruth H. Cooperrider
Ombudsman

RHC/JB/jbc

1002512d

**DEPARTMENT OF HUMAN SERVICES' RESPONSE
TO REQUEST FOR ADDITIONAL INFORMATION**



Iowa Department of Human Services

Terry E. Branstad
Governor

Kim Reynolds
Lt. Governor

Charles M. Palmer
Director

AUG 21 2013

Ms. Ruth H. Cooperrider
Citizens' Aide/Ombudsman
Ola Babcock Miller Building
1112 East Grand Avenue
Des Moines, IA 50319

Dear Ms. Cooperrider:

Please find the following response in reference to your follow-up request for additional information regarding the Ombudsman's investigative report reflecting the Department of Human Services' oversight of a licensed child care center owned and operated by Children and Families of Iowa.

Request #1

Please see attached documents entitled, 'Work Flow for Provisional License', 'Work Flow for 2nd Provisional License' and 'Child Care Licensing Decisions'.

Request #2

The following proposed rules were filed on August 13, 2013 with a targeted effective date of February 1, 2014.

109.10(10) Recording incidents. Incidents involving a child, including minor injuries, minor changes in health status, or other minor behavioral concerns, shall be reported to the parent on the day of the incident. Incidents resulting in an serious injury to a child, or incidents resulting in a significant change in the health status of a child shall be verbally reported to the parent on the day of the incident immediately. The parents of any child included in incidents involving inappropriate sexually acting out behavior will be notified immediately after the incident. A written report, fully documenting every incident, shall be provided to the parent or person authorized to remove the child from the center. The written report shall be prepared by the staff member who observed the incident and a copy shall be retained in the child's file.

Request #3

Please see attached document entitled, 'Work Flow for Founded Abuse in Child Care'.

Request #4

The following proposed rules were filed on August 13, 2013 with a targeted effective date of February 1, 2014.

a. Postings are required for the certificate of license, notice of exposure of children to a communicable disease, and notice of actions to deny, suspend, or revoke, or reduce the center's license to a provisional status. ~~†~~The center's license, reflecting current regulatory status and all other required postings shall be conspicuously placed at the main entrance to the center. If the center is located in a building used for additional purposes and shares the main entrance to the building, the required postings shall be conspicuously placed in the center in an area that is frequented daily by parents or the public.

Request #5

The following statement will be added to the QRS website, effective September 1, 2013:

Ratings reflect information provided by the program at their time of rating. If a program's child care license or registration is revoked during the rating period, their QRS rating is also revoked. The QRS status of a program does not reflect other infractions that may occur during the certification period. In choosing a child care program, parents should discuss the current licensing status with the program and be aware that child care centers are required to prominently post provisional licenses.

Please feel free to contact me if you have any additional questions.

Sincerely,



Charles M. Palmer
Director

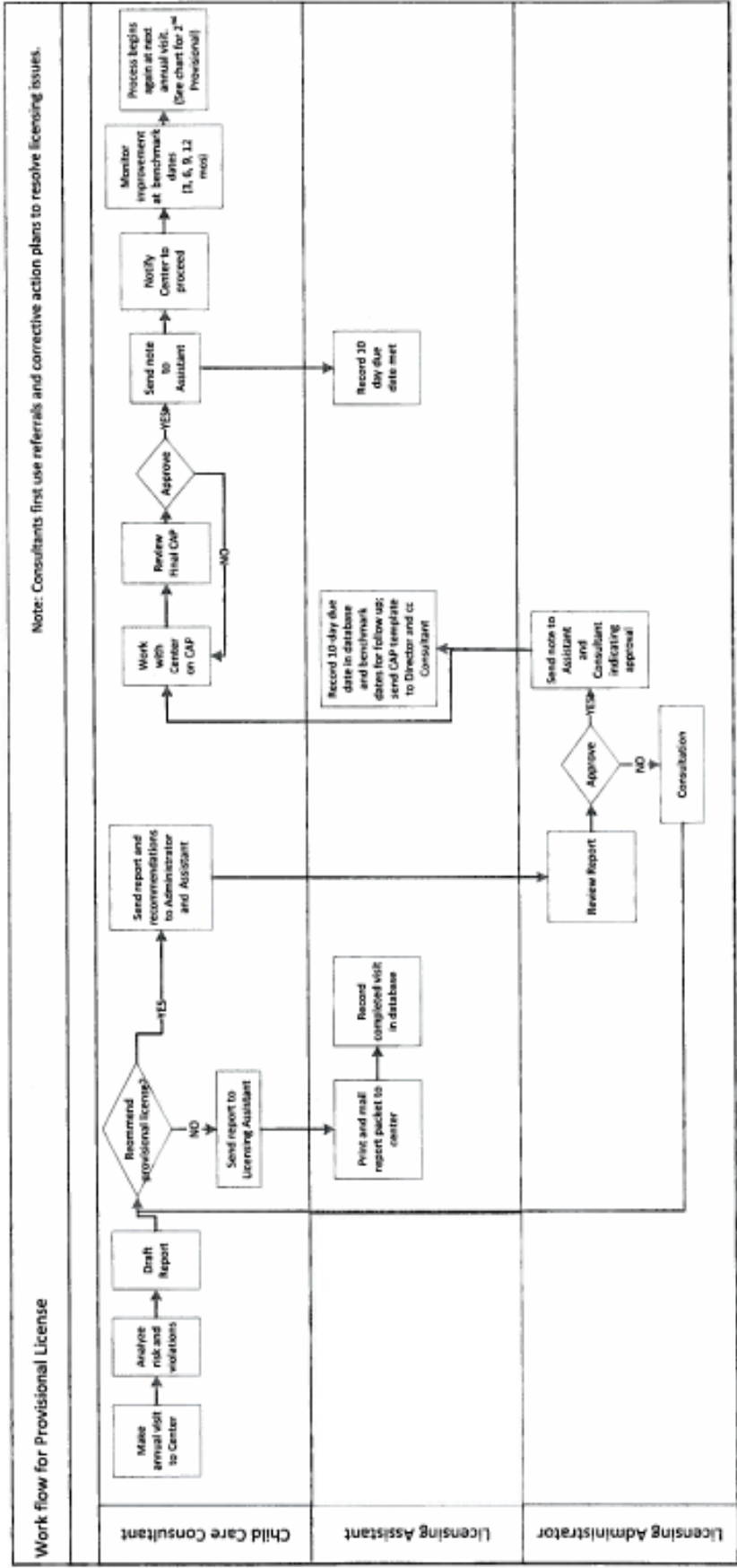

12/2012

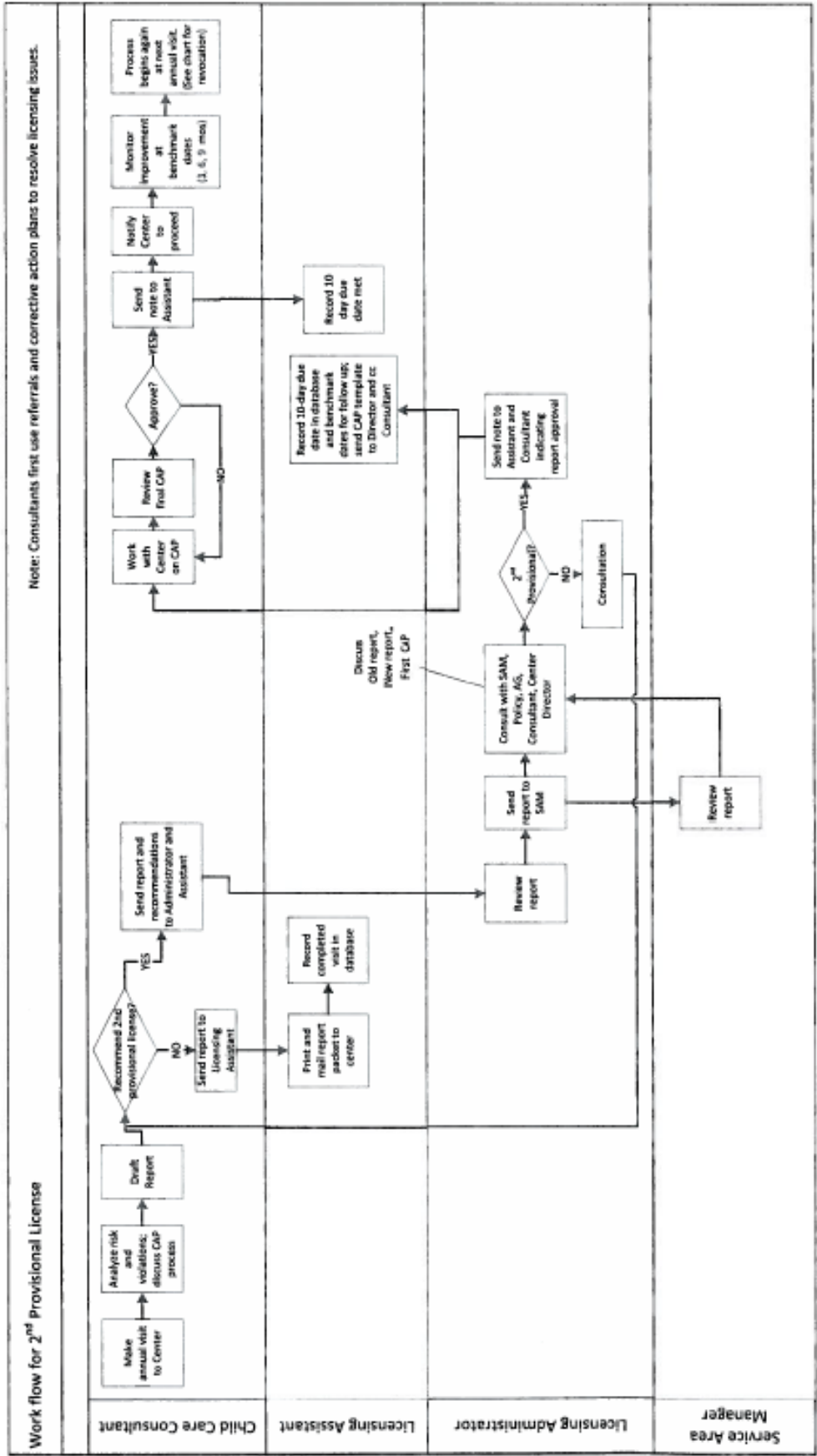

12/2012

Child Care Licensing Decisions:

Step 1: Evaluation

Consultants should evaluate risk of harm and patterns of disregard to licensing rules to determine a course of action. The degree of engagement, understanding and planning assist in evaluating performance patterns.

Risk of Harm. Evaluate the probability or likelihood that a child will be harmed. The highest risk factor is the driving consideration in working with the matrix below.

Pattern of Disregard. Primarily this is a review of the number and prevalence of deficiencies across the service provision however the following reflective questions offer greater perspective.

Engagement

1. In what ways has the center engaged as active partners in the service provision and assessment? Do they use CCR&R? Do they rely on board members/ advisory group/ community stakeholder? Are they active with quality certifications?
2. What engagement, support and intervention techniques are working at the center so far?

Understanding

1. What has the center identified as their strengths and needs?
2. What are the presenting problems and underlying issues? Are they clearly identified and agreed upon?
3. For risks that are identified? How is it mitigated? How is it understood?

Planning

1. Do the agency goals align with mitigating focal problems, functional challenges, risks, and underlying conditions? Are they agreed upon?
2. What is the long-term guiding view for this the children's health & safety, school readiness and social development?
3. What sustainable supports (formal and informal) are being planned? How will these supports enable the center to function safely and successfully?

Step 2: Determine Course of Action

Risk How likely could harm occur?	High	CAP	Provisional	Revocation
	Medium	Drop In or other assurance	CAP	Provisional
	Low	No action	Drop In or other assurance	CAP
		Slight	Moderate	Serious
Pattern of Disregard related to Licensing Standards To what degree have rules been violated?				

<p>Risk examples High: Supervision/Ratio violations, environmental health violations Medium: Training, general quality issues related to supervision & nutrition Low: policy and file management issues.</p>	<p>Pattern of disregard threshold: Slight = 0-7 Moderate = 8-15 Serious = 16+</p>
--	---

1. **Drop in or Other Assurance.** Follow up or referral is necessary to ensure conformity of moderate number of violations that are of lower to medium risk of harm. Resolution verified by other stakeholders would not necessarily result in the need for DHS to re-visit.
2. **Corrective Action Plan (CAP).** Child Care Centers may be required to submit Corrective Action Plans when performance is determined to be:
 - High risk of harm and slight pattern of disregard to licensing standards or
 - Moderate risk of harm and moderate disregard of licensing standards or
 - Low risk of harm and serious disregard to licensing standards
3. **Provisional License** (CAP is required to issue a provisional license). A provisional license should be issued when performance is determined to be:
 - High risk of harm and moderate disregard to licensing standards or.
 - Moderate risk of harm and serious disregard to licensing standards

109.2(3) Provisional license.

- a. A provisional license may be issued or a previously issued license may be reduced to a provisional license for a period up to one year when the center does not meet all standards imposed by law and these rules.
- b. A provisional license shall be renewable when written plans giving specific dates for completion to bring the center up to standards are submitted to and approved by the department. A provisional license shall not be reissued for more than two consecutive years when the lack of compliance with the same standards has not been corrected within two years.
- c. When the center submits documentation or it can otherwise be verified that the center fully complies with all standards imposed by law or these rules, the license shall be upgraded to a full license.

Note: CAP's are due within 10 days of the provider receiving the report. At least quarterly, the child care consultant must monitor the plan until the CAP is resolved.

4. Non-renewal or Revocation

**** If there has been no resolution with the provisional license, proceed with either not renewing a license or revoking a license.**

109.2(4) Denial. Initial applications or renewals shall be denied when:

- a. The center does not comply with center licensing laws and these rules in order to qualify for a full or provisional license.
- b. The center is operating in a manner which the department determines impairs the safety, health, or well-being of children in care.
- c. A person subject to an evaluation has transgressions that merit prohibition of involvement with child care and of licensure, as determined by the department.
- d. Information provided either orally or in writing to the department or contained in the center's files is shown to have been falsified by the provider or with the provider's knowledge.
- e. The center is not able to obtain an approved fire marshal's certificate as prescribed by the state fire marshal in 661—Chapter 5 or Iowa Code chapter 100 or fails to comply in correcting or repairing any deficiencies in the time determined by the fire marshal or the fire marshal determines the facility is not safe for occupancy.
- f. The regulatory fee as specified in subrule 109.2(7) is not received by the department's division of fiscal management by the due date indicated on Form 470-4834, Child Care Center Licensing Fee Invoice.

109.2(5) Revocation and suspension. A license shall be revoked or suspended if corrective action has not been taken when:

- a. The center does not comply with center licensing laws or these rules.
- b. The center is operating in a manner which the department determines impairs the safety, health, or well-being of the children in care.
- c. A person subject to an evaluation has transgressions that merit prohibition of involvement with child care and of licensure, as determined by the department.

- d. Information provided to the department or contained in the center's files is shown to have been falsified by the provider or with the provider's knowledge.
- e. The facility is not able to obtain an approved fire marshal's certificate as prescribed by the state fire marshal in 661—Chapter 5 or Iowa Code chapter 100 or fails to comply in correcting or repairing any deficiencies in the time determined by the fire marshal or the fire marshal determines the facility is not safe for occupancy.
- f. The regulatory fee as specified in subrule 109.2(7) is not paid in full due to insufficient funds to cover a check submitted to the department for the fee.

Note: Consideration for non-renewal or revocation will be considered if:

If there has been no resolution with the provisional license, OR
 Employment of person with a transgression, OR
 Falsified documents, OR
 Unable to obtain an approved fire marshal's certificate, OR
 Regulatory fee not paid by the due date.

Step 3: Resolve Course of Action

Center Effort to close their CAP

- 1. Has the center engaged as active, ongoing participants in the service implementation process?
- 2. How are supports, services and PIP being implemented?
- 3. How does the center and resource team members fulfill their roles and responsibilities to ensure that services are of sufficient intensity, duration and continuity to achieve desired results?
- 4. What positive changes are being observed?

Follow up visit, in an effort to close their CAP.

- 1. What positive changes are being observed?
- 2. How has the center demonstrated functional improvement in routine daily activities?
- 3. How is the center demonstrating functional improvement in safe and dependable caregiving?
- 4. How are known risks of harm being reduced or properly managed?
- 5. What has been done to establish an adequate and sustainable support network for the center?
- 6. How satisfied is the consultant, providers and parents with the services provided and the results achieved?
- 7. What other barriers, successes and assistance is known?

Work Flow for Founded Child Abuse in Child Care (06*2012)

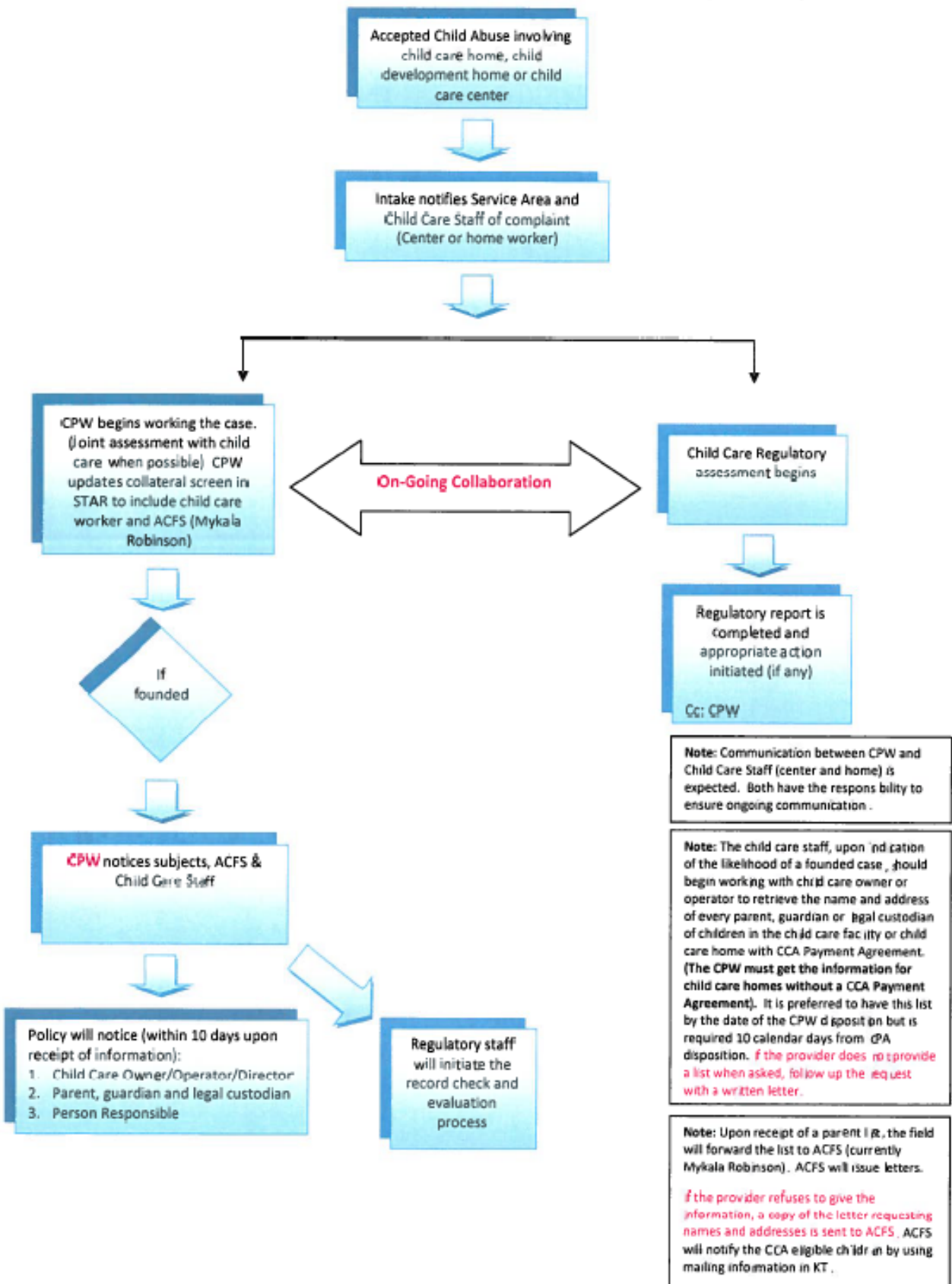



Iowa Department of Human Services

Terry E. Branstad
Governor

Kim Reynolds
Lt. Governor

Charles M. Palmer
Director

August 27, 2013

Ms. Ruth H. Cooperrider
Citizens' Aide/Ombudsman
Ola Babcock Miller Building
1112 East Grand Avenue
Des Moines, IA 50319
L O C A L

Dear Ms. Cooperrider:

I am writing in response to your letter dated August 9, 2013, regarding the investigative report of the Department of Human Services' oversight of a licensed child care center owned and operated by Children and Families of Iowa. You requested that the Department determine if we have any confidentiality objections.

The Department has reviewed your report and we have determined there are no concerning issues with respect to confidentiality within the report.

Sincerely,

A handwritten signature in black ink that reads "C M Palmer".

Charles M. Palmer
Director

CMP/mmr

LETTER FROM CHILDREN & FAMILIES OF IOWA



children & families of iowa
Restoring hope. Building futures. Changing lives.

1111 University Avenue, Des Moines, IA 50314
Phone: (515) 288-1981 • Fax: (515) 288-9109
www.cfiowa.org

September 10, 2013

Ms. Ruth H. Cooperrider
Citizens' Aide/Ombudsman
Ola Babcock Miller Building
1112 East Grand Avenue
Des Moines, IA 50319

Dear Ms. Cooperrider:

We appreciate the opportunity to review this report, and have just a few observations.

Although Children & Families of Iowa disagreed with many of the Department of Human Services allegations from 2010 cited in this report, we always work to find ways to improve our services for children and families. Many improvements have been made at our Child Development Center (CDC) since spring of 2010, a time when the CDC had recently experienced a change in leadership. In 2011, we returned to operation under full licensure, and have consistently maintained a DHS Quality Rating System score of 4 on a 1 to 5 scale, which is very good for a large center such as the CDC. We welcome the rigorous licensing reviews that we receive on an annual basis and any other assessments that are instructive and aimed at quality improvement. The CDC recently celebrated its 30th anniversary of serving children, their families and the community, and looks forward to continuing its mission of helping children to achieve brighter futures.

Sincerely,

Gloria Gray
Chief Executive Officer
Children & Families of Iowa

OMBUDSMAN'S COMMENT

As provided in Iowa Code section 2C.16, I submitted the initial version of this report to DHS Director Charles Palmer on June 20, 2013, for review and reply. In his July 31, 2013, written response, Mr. Palmer objected to the title of the report. After considering Mr. Palmer's objection, I have changed the report title in this published version.

My office's investigation did not focus on the actions of the Child Development Center or its employees, and I do not criticize the center in my conclusions or recommendations. However, because the center is identified in this report as the subject of the DHS's regulatory actions, I agreed to append to the report a letter from the chief executive officer of the organization that operates the center.