



Late Life Low Cost Deck Overlays



FINAL REPORT

March 10, 2020

WJE No. 2018.8347

PREPARED FOR:

The Iowa Highway Research Board
TR-775

PREPARED BY:

Mohamed K. ElBatanouny, Ph.D., S.E., P.E.

Le T. Pham, Ph.D.

Kathleen A. Hawkins

Paul D. Krauss, P.E.

Wiss, Janney, Elstner Associates, Inc.



DISCLAIMER

The contents of this report reflect the views of the authors, who are responsible for the facts and the accuracy of the information presented herein. The opinions, findings, and conclusions expressed in this publication are those of the authors and not necessarily those of the sponsors.

The sponsors assume no liability for the contents or use of the information contained in this document. This report does not constitute a standard, specification, or regulation. The sponsors do not endorse products or manufacturers. Trademarks or manufacturers' names appear in this report only because they are considered essential to the objectives of the document.

STATEMENT OF NON-DISCRIMINATION

Federal and state laws prohibit employment and/or public accommodation discrimination on the basis of age, color, creed, disability, gender identity, national origin, pregnancy, race, religion, sex, sexual orientation or veteran's status. If you believe you have been discriminated against, please contact the Iowa Civil Rights Commission at 800-457-4416 or Iowa Department of Transportation's affirmative action officer. If you need accommodations because of a disability to access the Iowa Department of Transportation's services, contact the agency's affirmative action officer at 800-262-0003.



Late Life Low Cost Deck Overlays Final Report

Sponsored by:

**The Iowa Highway Research Board
TR-775**

Prepared by:

**Mohamed K. ElBatanouny, Le T. Pham, Kathleen A. Hawkins, and
Paul D. Krauss**

**Wiss, Janney, Elstner Associates, Inc.
Northbrook, Illinois**

March 10, 2020



TECHNICAL REPORT DOCUMENTATION PAGE

1. Report No. TR-775	2. Government Accession No.	3. Recipient's Catalog No.	
4. Title and Subtitle Late Life Low Cost Deck Overlays		5. Report Date March 10, 2020	
		6. Performing Organization Code WJE No. 2018.8347	
7. Author(s) Mohamed K. ElBatanouny, Ph.D., S.E. http://orcid.org/0000-0001-9029-2104 Le T. Pham, Ph.D. http://orcid.org/0000-0002-6348-4204 Kathleen A. Hawkins, http://orcid.org/0000-0001-8447-987X Paul D. Krauss, P.E. http://orcid.org/0000-0002-0107-6256		8. Performing Organization Report No. WJE No. 2018.8347	
9. Performing Organization Name and Address Wiss, Janney, Elstner Associates, Inc. 330 Pfingsten Rd Northbrook, Illinois 60062		10. Work Unit No.	
		11. Contract or Grant No. TR-775	
12. Sponsoring Agency Name and Address Iowa Department of Transportation Iowa Highway Research Board (IHRB) 800 Lincoln Way Ames, IA 50010		13. Type of Report and Period Covered Final Report (May 2019- March 2020)	
		14. Sponsoring Agency Code TR-775	
15. Supplementary Notes			
16. Abstract <p>Low-slump dense concrete overlays (LSDC) are typically used by the Iowa DOT to provide long-term performance. However, due to their relatively high costs and long curing, LSDC overlays may not be the optimal solution for late-life bridge decks that require a short service life extension prior to replacement. A literature review and cost-benefit analysis were conducted to identify potential late-life overlays that are less expensive and have a smaller traffic impact than the LSDC overlay. Federal and state research on overlays and the standards of eleven states in the Midwest and three additional states (California, New York, and Virginia) were reviewed. Seven types of overlays were selected for comparison to the LSDC overlay as follows: LMCVE, PPCO, thin polymer, HMA overlays, PMA overlays, and HMA overlays with waterproofing membranes (WPM). Reinforced asphalt overlays were also identified as potential late-life overlays, but due to lack of data and literature, could not be included in the analysis. A reduced construction procedure that does not require partial-depth repairs was also considered in addition to the standard procedure used by the Iowa DOT. Results of the analysis show that all of the overlays investigated can reduce the traffic closures by half the time and several overlay-construction procedure combinations can significantly reduce the cost compared with the LSDC overlay. Recommendations for selecting the optimal late life overlays based on the targeted remaining service life were presented in terms of a decision making table that classifies the different options based on cost, traffic closure times, and expected service life. Field studies are recommended to verify the benefits of and service life associated with the reduced construction procedure discussed in this study. Additionally, it is recommended that a more refined cost-benefit analysis be conducted for bridges with varying deck conditions and service life requirements to confirm the general applicability of the results of this study.</p>			
17. Key Words Bridge, deck, late life overlays, low cost		18. Distribution Statement No restrictions. This document is available to the public from the sponsoring agency.	
19. Security Classif. (of this report)	20. Security Classif. (of this page)	21. No. of Pages 120	22. Price

EXECUTIVE SUMMARY

When a bridge deck is considered for replacement, it is not uncommon that the deck needs significant repairs to maintain the riding surface until funding is available for the replacement and a construction contract can be executed. Traditionally, Iowa DOT has used low slump portland cement concrete overlays on bridge decks, which can provide a significant service life extension. Low-slump overlays, however, have significant costs and traffic impacts during construction. For bridges with a limited remaining service life, other deck overlay options that have lower costs and traffic impacts while maintaining the riding surface may be desirable. The goal of this study is to identify overlay options that have lower costs and traffic impacts than the standard overlays currently used by the Iowa DOT, which are more desirable for a bridge deck with a limited remaining service life.

In this study, different overlay materials and reduced construction procedures were evaluated for short extensions of late-life decks. Cost and traffic impact reductions can be obtained by changing two components of an overlay system: materials and construction. Apart from low slump concrete used by Iowa DOT (Class O), other hydraulic cement concrete overlays have been used including silica fume concrete, latex-modified concrete, high performance concrete, and ultra-high performance concrete. These concrete overlays typically require at least three days of curing, substantially disrupting traffic. Materials that require shorter curing times than conventional portland cement concrete such as polymer concrete, rapid set concrete, or asphalt can reduce traffic impacts. Mixer-blended polyester polymer concrete overlays (PPCO), typically 3/4 inch or thicker, can be installed quickly and provide significant service life extensions. Thin polymer overlays, typically applied in multiple (broom and seed) layers to achieve a thickness of 1/4 to 1/2 inch, can be installed quickly and have reduced cost. Hot mix asphalt concrete (HMA) overlays can be low-cost and installed quickly. While HMA overlays with a water proofing membrane can provide significant service life extensions, HMA overlays without a membrane may be acceptable as a very short-term solution.

A reduced construction procedure that lowers or removes certain construction requirements can reduce both costs and traffic impacts. The standard overlay procedure by Iowa DOT involves surveying for and removing delaminated concrete to maximize service life of the overlay. While important for long-term durability, these processes are labor- and time-consuming and can add a significant cost to the overlay project. For decks that have a short remaining service life, removal of deteriorated concrete before placement of the overlay may be omitted or lessened to decrease cost and construction time, which is an approach followed by some DOTs as identified in the study.

Before selecting an overlay system and construction process, decks must be evaluated, and the required life extension determined. Factors in the selection process include: condition of the deck, minimum service life extension desired, traffic impacts during construction, traffic loading such as ADTT, costs, availability of materials and contractors, and time of year. Through a literature review and cost-benefit analysis for a typical late-life deck condition, this study provides a discussion of the advantages and disadvantages of different overlay materials and construction procedures that have been used by other states compared with standard Iowa practice. The different combinations of overlay materials and construction procedures have been sorted by service life extension and ranked in terms of cost and traffic impact. Finally, standard details and specifications of promising late-life overlays have been drafted and can be incorporated into Iowa standard specifications or used to develop special provisions for late life overlay projects in Iowa.

ACKNOWLEDGEMENTS

The financial support provided by the Iowa Highway Research Board (IHRB) is gratefully acknowledged. The authors would like to thank Mr. Michael Todsén - Iowa DOT Office of Bridges and Structures and other TAC members including Ms. Vanessa Goetz - Iowa DOT Office of Research & Analytics, Mr. David Evans - Iowa DOT Office of Bridges and Structures, and Mr. Gregg Durbin - Iowa DOT District 1 Materials Engineer, for their input throughout the project.

CONTENTS

Chapter 1. Introduction	1
1.1. Background.....	1
1.2. Objectives	2
1.3. Layout of Report	2
Chapter 2. Literature Review	3
2.1. Overlay Types.....	3
2.2. Standard Bridge Deck Overlay Practice in Iowa	4
2.3. Bridge Deck Overlay Practices by Other State DOTs.....	5
2.3.1. Hydraulic Cement Concrete Overlays	5
2.3.2. Polymer Concrete Overlays.....	6
2.3.3. Asphalt Overlays	7
2.4. Reinforced Overlays.....	10
Chapter 3. Analysis of Candidates for Late Life Low Cost Overlays	12
3.1. Cost-Benefit Analysis.....	12
3.1.1. Overlay Types for Cost-Benefit Analysis.....	12
3.1.2. Construction Procedures	12
3.1.3. Deck Condition	16
3.1.4. Construction duration	16
3.1.5. Cost Estimate.....	17
3.1.6. Cost-Benefit Comparison and Discussion.....	19
3.2. Selection of overlay solutions for late-life deck	19
3.3. Sensitivity of Cost to Repair Area.....	23
3.4. Standard Details and Specifications for Overlay Candidates.....	26
Chapter 4. Conclusions and Recommendations.....	30
4.1. Summary and Conclusions	30
4.2. Recommendations	31
4.3. Implementation.....	32
Bibliography.....	33
APPENDIX A. Expanded literature review	
A.1 Comparison between Overlay Types.....	37
A.1.1 Performance/Service Discussion	37

A.1.2 Ease of Construction Discussion.....	41
A.2 Nation-Wide Practice	41
A.3 Details of State Practices.....	46
A.3.1 PCC and LSDC overlays	46
A.3.2 MSC/SFC overlays.....	47
A.3.3 LMC and LMCVE overlays.....	48
A.3.4 Polymer concrete overlays	49
A.3.5 Asphalt overlays.....	50

APPENDIX B. Specifications for Late Life Deck Overlays

Appendix B.1 - Iowa DOT Special Provisions for Very High Early Strength Latex Modified Concrete Overlay	53
Appendix B.2 - Iowa DOT Special Provisions for Polyester Polymer Concrete Overlay.....	62
Appendix B.3 - Iowa DOT Special Provisions for Thin Polymer Concrete Overlay	72
Appendix B.4 - Draft Specifications for Hot Mixed Asphalt Overlay with Waterproofing Membrane	79
Appendix B.4.1- Michigan DOT Standard Specifications Section 710. Waterproofing Membrane and.....	82
Appendix B.4.2 - Michigan DOT Qualified Waterproofing Membrane Products.....	91
Appendix B.4.3 - Nebraska DOT Special Provisions for Cold Liquid-Applied Membrane	93
Appendix B.5 - Draft Specifications for Hot Mixed Asphalt Overlay without Waterproofing Membrane..	102
Appendix B.6 - Kentucky DOT Special Note for Asphalt Waterproofing Mix For Bridge-Deck Overlays....	104

Tables

Table 2-1. Requirements for Class O and Class HPC-O concrete overlays. (Iowa DOT, 2019).....	4
Table 2-2. Qualitative comparison between overlay types. A checkmark represents a relatively advantageous feature. A cross represents a relatively disadvantageous feature.	8
Table 2-3. Bridge Overlay Types Specified by State DOTs’ Standard Specifications and Manuals.....	9
Table 3-1. Deck Condition.....	16
Table 3-2. Estimated Construction Durations (days) for Different Overlay Types and Procedures	17
Table 3-3. Unit Costs of Overlays (Materials and Installation) and Associated Tasks	17
Table 3-4. Estimated Overlay Costs - Standard procedure.....	18
Table 3-5. Estimated Overlay Costs - Reduced Procedure.....	18
Table 3-6. Comparison of Different Overlay Systems - Standard Construction Procedure.....	21
Table 3-7. Comparison of Different Overlay Systems - Reduced Construction Procedure.....	21
Table 3-8. Selection of Overlays for Different Service Life Categories	22
Table A-1. Qualitative comparison between overlay types. A checkmark represents a relatively advantageous feature. An x represents a relatively disadvantageous feature.	39
Table A-2. Description of the percentage of respondents in Krauss et al. (2009) to use each type of overlay for the following bridge deck conditions.....	42
Table A-3. SFC overlay mixture designs, according to NYSDOT, Missouri DOT, and Ohio DOT.....	47
Table A-4. LMC overlay mixture designs, according to Missouri DOT and Ohio DOT.....	48
Table A-5. LMCVE overlay mixture designs, according to Missouri DOT and Virginia DOT.....	49

Figures

Figure 3-1. Plot showing how the percent difference in cost between each overlay and the baseline overlay varies with the percent of deck area requiring Class A repairs. Solid lines indicate overlays using standard procedure. Dotted lines indicate overlays using reduced procedure.....24

Figure 3-2. Bar graph showing cost ranking of overlays that are assumed to be capable of providing between 5 and 10 years of additional service varies with the percent of the deck area requiring Class A repairs. Any changes in ranking are circled. (Note: overlays capable of providing more than 10 years of additional service are not shown in this graph).....25

Figure 3-3. Bar graph showing cost ranking of overlays that are assumed to be capable of providing between 10 and 15 years of additional service varies with the percent of the deck area requiring Class A repairs. Any changes in ranking are circled.....25

Figure 3-4. TPO, longitudinal section at a typical location along roadway (section at joint similar)26

Figure 3-5. All overlay types except TPO, longitudinal section at a typical location along roadway27

Figure 3-6. Concrete and PPCO overlays, longitudinal section at joint28

Figure 3-7. HMA and PMA overlays, longitudinal section at joint29

Figure A-1. States with experience placing overlays on badly-deteriorated decks and the types of overlays used, as reported to Ramey and Oliver (1998). Comments provided by states regarding service life of these overlays is included (created with mapchart.net).43

Figure A-2. States with experience placing overlays and the types of overlays used, as reported to Krauss et al. (2009) (created with mapchart.net).44

Figure A-3. The types of cementitious overlays used in the United States and Canada, as reported to Krauss et al. (2009) (created with mapchart.net).....45

Figure A-4. The types of bituminous overlays used in the United States and Canada, as reported to Krauss et al. (2009 (created with mapchart.net).46

CHAPTER 1. INTRODUCTION

1.1. Background

Bridge rehabilitation or replacement is required when maintenance methods can no longer improve the serviceability of the deck sufficiently or for adequate periods of time. However, because rehabilitation and replacement projects are much more expensive, funds are limited, and deteriorated bridges are numerous, not all of the bridges can receive their required rehabilitation or replacement at the same time. Instead the projects are prioritized by deterioration severity, traffic demand, project cost, and risk associated with not providing a full replacement. Low-priority bridges are often given a protective overlay to extend the life of their deck until funding is available for their replacement.

In these scenarios, overlays are placed late in the life of the bridge deck and may only be intended to extend the life by several years. The optimal overlay fulfills these service requirements at the lowest cost and lowest disruption to traffic. Common overlays include asphalt overlays with or without membranes, latex-modified concrete overlays, silica fume concrete overlays, rapid set concrete overlays, and low-slump or dense concrete overlays. The Iowa Department of Transportation (DOT) currently relies either on low-slump (Class O) or high-performance (Class HPC-O) portland cement concrete overlays. These overlays improve the ride quality and skid resistance of the bridge, protect the underlying concrete from additional moisture and chloride ingress. However, they require a relatively long curing time, typically 72-hour moist curing, substantially disrupting traffic. They also may have higher cost and longer life than needed compared to other lower cost overlay systems.

Overlays have been used in the states since the late 1950s. A variety of overlay types with variable service life benefits, costs, and construction durations have been developed since overlays were first used and multiple states such as Wisconsin and Virginia and federal agencies, including the federal highway administration, and Transportation Research Board (TRB), have invested in studies and reviews to compile the types and document their costs, expected service life, suitable applications, and advantages and disadvantages (Balakumaran, Weyers, & Brown, 2017; Wisconsin Department of Transportation, 2019; Ramey & Oliver, 1998; Krauss, Lawler, & Steiner, 2009). However, information specifically for overlays placed on older deteriorated decks is limited.

There is a multitude of different types of overlays that have been used on bridge decks and most have substantial literature describing their advantages; however, performance data is often limited. Desirable characteristics of bridge deck overlays include:

- Low cost,
- Long service life extension,
- Short construction time,
- Easy application,
- Strong bond with the underlying deck,
- Good ride quality and skid resistance,
- Minimal material shrinkage,
- A thermal coefficient of expansion similar to that of the original deck, and

-
- Light weight.

In the context of late-life overlay application, a long service life extension may not always be required because full deck replacement is scheduled within a few years. For example, an additional service life of 5 years may be required to procure funding for full deck replacement whereas many bridge deck overlays can extend service life by over 20 years (Guthrie and Ross 2006). An overlay that improves the structural capacity of the bridge is also a relatively low priority. Overlays placed in late-life of the deck are primarily placed to improve or maintain ride quality and skid resistance and address material degradation. Important overlay properties include rapid installation, good bond with existing deck, adequate toughness to resist future deck deterioration, and low cost. Finally, the selection of the optimum overlay system may be influenced by the existing condition of the deck.

The goal of this study is to identify overlay options that have lower costs and/or traffic impacts than the standard overlays currently used by the Iowa DOT. Cost and traffic impact reductions can be obtained by changing two components of an overlay system: materials and/or construction. Materials that require shorter curing times than conventional portland cement concrete such as polymer concrete, rapid set concrete, or asphaltic concrete can reduce traffic impacts. A reduced construction procedure that lowers or removes certain construction requirements can reduce both costs and traffic impacts. In this study, different combinations of overlay materials and construction procedures were evaluated in the context of late-life applications and compared to aid in the decision making process for placement of late-life overlays.

1.2. Objectives

The primary objective of this study is to identify late-life bridge deck overlay systems that will provide a sufficient service life extension but will be more cost-effective and require less closure time than conventional overlays currently used by the Iowa DOT. The most promising late-life deck overlay systems were identified by comparing benefit-cost ratios based on recent cost database and service life information.

Drafts of standard special provision specification and design details were collected from the different state DOTs and included in the report.

1.3. Layout of Report

This report consists of four chapters. This chapter presents the background, purpose, and objectives of this research study along with the layout of the report.

Chapter 2 provides a summary of the literature review on different overlay types used by Iowa DOT and other state agencies. Qualitative evaluation of the overlays and their use by states are presented and summarized.

Chapter 3 presents a cost-benefit analysis of the different overlay materials. A reduced construction procedure was considered and compared with the Iowa DOT standard procedure for overlays. Rankings of different overlays options were provided to assist selection of the optimum overlay solutions given a desired service life. Standard details and specifications for the different overlay types and construction procedures were drafted.

Chapter 4 summarizes the findings, conclusions, and recommendations for future implementation of late life bridge deck overlays.

CHAPTER 2. LITERATURE REVIEW

A comprehensive literature review of bridge deck overlay practices was completed for eleven Midwest states including Illinois, Indiana, Kansas, Michigan, Minnesota, Missouri, Nebraska, North Dakota, Ohio, South Dakota, and Wisconsin. Practices in three additional states (California, New York, and Virginia) were also reviewed to cover overlay types not commonly used in the Midwest. This chapter provides an overall summary of the literature and identifies overlays specific to late-life applications. An expanded literature review with more detailed discussion on the properties and popularity of each overlay type is provided in Appendix A.

2.1. Overlay Types

Bridge deck overlays can be divided into two groups: unreinforced and reinforced. Eleven unreinforced bridge deck overlay types have been identified in the literature, and they can be classified into three subgroups based on the types of binder as listed below, including hydraulic cement concrete overlays, polymer concrete overlays, and asphalt overlays. Their use in Iowa and other states is discussed in Sections 2.2 and 0.

- Unreinforced overlays:
 - Hydraulic cement concrete overlays:
 - Portland cement concrete (PCC) overlays
 - Low-slump, dense concrete (LSDC) overlays
 - High performance concrete and silica fume concrete (HPC and SFC) overlays
 - Ultra-high performance concrete (UHPC) overlays
 - Latex-modified concrete (LMC) overlays
 - Very early strength LMC (LMC-VE) overlays
 - Polymer concrete overlays:
 - Thin broom-seed polymer concrete overlays (TPOs)
 - Premixed polymer concrete overlays (PPCOs)
 - Asphalt overlays:
 - Hot-mixed asphalt (HMA) overlays (without waterproofing membranes)
 - HMA with waterproofing membranes
 - Polymer-modified asphalt (PMA) overlays

Four reinforced overlay types have been identified in the literature and listed below. These overlays have been used on an experimental basis and currently not specified in the standard specifications of any of the states in this review. Characteristics of the reinforced overlays are briefly discussed in Section 2.4 for completeness.

- Reinforced overlays:
 - Reinforced concrete (RC) overlays
 - Reinforced asphalt overlays
 - Fiber-reinforced concrete (FRC) overlays
 - Fiber-reinforced asphalt concrete (FRAC) overlays

2.2. Standard Bridge Deck Overlay Practice in Iowa

Bridge deck overlays are described in the Iowa DOT Standard Specifications for Highway and Bridge Construction, Section 2413, *Bridge Deck Surfacing, Repair, and Overlay*. Standard overlays use low slump concrete (Class O) or high-performance concrete (Class HPC-O) mixtures. Key material properties of the mixtures are summarized in Table 2-1. Of the two mixtures, Class O concrete overlay typically has lower cost than Class HPC-O overlay.

Iowa DOT Construction Manual, Section 11.60, *Decks and Overlays*, outlines the standard installation procedures for these overlays. The general procedure is summarized as follows:

1. Remove existing overlay or chloride-contaminated concrete to desired depth and prepare concrete deck for application of new overlay.
2. Remove delaminated and unsound concrete using a method that minimizes damage to underlying reinforcing steel and is approved by the project engineer.
3. Repair spalled, delaminated, and other unsound areas.
4. Sandblast any exposed reinforcement such that all rust, contaminants, and unsound concrete is removed.
5. Air blast surface to remove dust and other particles and cover to prevent contamination.
6. Place overlay.
7. Cure overlay for 72 hours.
8. Apply texture by cutting into or grinding the hardened concrete.

Table 2-1. Requirements for Class O and Class HPC-O concrete overlays. (Iowa DOT, 2019)

Property	Class O Requirement	Class HPC-O Requirement
Slump, inches	Target: 3/4 Max: 1	Target: 1 to 4 Max: 5
Air content, %	Target: 6.5 Max: 8.5 Min: 5.5	Target: 6.5 Max: 8.5 Min: 5.5
Water/cement ratio	Target: 0.33	Target: 0.40 Max: 0.42
Cement content, %vol	0.156	0.134
Cement type & SCM replacement	Up to 20% fly ash replacement permitted	Use of blended cement required If blended cement is not used, then 25% GGBFS replacement required Up to 20% fly ash replacement permitted

2.3. Bridge Deck Overlay Practices by Other State DOTs

This section summarizes the general use, characteristics, and costs of different overlay types. Relative advantages and disadvantages of the overlays are presented in Table 2-2. The types of overlays specified in the standards and manuals of each state are summarized in Table 2-3, including Iowa DOT overlay materials. More detailed discussion on properties of the overlays is given in Appendix A.

2.3.1. Hydraulic Cement Concrete Overlays

2.3.1.1. Portland cement concrete (PCC) overlays

Conventional PCC overlays are widely used as a long-term solution. They are familiar to most concrete contractors and can provide service life extensions of over 15 years. However, long curing time of PCC will cause substantial disruptions to traffic. Use of Type III Portland cement can shorten curing time, but rapid setting Type III cement increases both shrinkage and cracking risk due to high temperatures during cement hydration. Regarding late-life applications, the Minnesota DOT noted that concrete overlays with a thickness of up to 3 inches may be placed without removal of deteriorated concrete on decks that are planned to be replaced within 5 years. Surface preparation consists of removing bituminous patches and scarifying 1/2-inch from the deck thickness, but does not require removal of deteriorated concrete, which can significantly reduce costs and construction time. In these scenarios, up to 10 to 15 years of service can be expected. The cost and benefit of not removing deteriorated concrete is evaluated in the Chapter 3.

2.3.1.2. Low-slump, dense concrete (LSDC) overlays

Low-slump, dense concrete (LSDC) overlays are widely used as a long-term solution. Maximum slump is typically 1 to 2 inches, which reduces the required water/cementitious materials (w/cm) ratio. LSDC concrete with low w/cm ratios is less permeable, and superior at preventing chloride ingress and moisture compared to conventional PCC overlays. Low-slump overlays are susceptible to shrinkage cracking and delamination, and require similar curing time to PCC overlays. LSDC overlays can provide service life extensions of over 18 years.

2.3.1.3. High performance concrete (HPC and SFC) overlays

HPC overlays contain special mineral and chemical admixtures that decrease concrete permeability. The most prominently used are silica fume concrete (SFC), also known as microsilica concrete (MSC), overlays. These concretes contain approximately 7% to 12% silica fume by weight of cement, which decreases permeability by packing into the pores of the cement paste and providing additional hydration products within these pores. Curing times of HPC overlays are similar to PCC. HPC overlays typically extend service life by over 15 years.

2.3.1.4. Ultra-high performance concrete (UHPC) overlays

UHPC is currently an experimental material for bridge deck overlays, and not specified in the standard specifications of any of the states included in this review. The Iowa DOT constructed its first trial UHPC overlay in 2016 and completed a short-term field study on the trial in 2018 (Wibowo & Sritharan, 2018). UHPC overlays contain high amounts of silica fume, steel fibers, and have very low w/cm ratios (typically 0.26 or less). Fly ash, slag, and lime filler may be used but coarse aggregates are not. Because of the low w/cm ratios and high amounts of silica fume, UHPC has a very low porosity, making it highly resistant to

ingress of both chlorides and moisture. UHPC overlays are expensive and require similar curing times to conventional PPC overlays.

2.3.1.5. Latex-modified concrete (LMC) overlays

LMC overlays have been widely used for bridge deck overlays and are expected to have long-term durability. LMC mixtures typically use portland cement or blended cements with an admixture of organic (styrene butadiene latex) particles suspended in water (Lane, 2013). These particles make the overlay less permeable and more resistant to chemical attacks. The polymer also improves adhesion to the original deck concrete and reduces shrinkage. Construction of LMC overlays requires specialized equipment and is sensitive to weather conditions. Plastic cracking has been a concern and cyclic freezing damage can occur if overlays are not formulated properly. LMC overlays require similar curing times to conventional PCC overlays (Lane, 2013), and typically provide service life extensions between 10 and 20 years. Some states noted that LMC overlays are more costly than silica fume and low-slump concrete overlays (Ramey & Oliver, 1998) while Indiana DOT noted LMC overlays have lower cost than LSDC.

2.3.1.6. Very early strength latex-modified concrete (LMCVE) overlays

LMCVE overlays are less common than LMC overlays. They use LMC mixtures with high early strength cements such as calcium sulfoaluminate cement (Virginia DOT) or ASTM C1157 Type HE cement (Missouri DOT) to shorten curing time and traffic disruption. An LMCVE project may only require 8 hours of closure (Balakumaran, Weyers, & Brown, 2017). However, the rapid setting of cement makes LMCVE overlays more sensitive to construction errors, which can result in poor bond between the overlay and the existing deck. If constructed correctly, these overlays can provide similar service life extensions to LMC. The incorporation of rapid-setting cement increases its cost compared to LMC, which may be offset by the shorter construction time (Martens, 2015).

2.3.2. Polymer Concrete Overlays

Polymer-based concretes typically utilize an organic resin such as polyester, epoxy, epoxy-urethane, or methyl methacrylate as the binder. Compared to conventional concrete, these materials have short construction periods but higher unit cost for materials. Below is a discussion on the two most common polymer concrete overlays.

2.3.2.1. Thin polymer concrete overlays (TPOs)

Thin polymer concrete overlays (TPOs) are widely used since they add minimal dead load while providing a surface that resists deicer salts from infiltrating the deck. TPOs are typically constructed in multiple layers where the resin binder is applied to the surface, the aggregates are broadcast on top, and the process is repeated until the desired thickness, typically between 1/4-inch and 1/2-inches, is achieved. Epoxy is the most commonly-used binder for TPOs but polyester, methyl methacrylate and epoxy-urethane have been used as well. The Wisconsin DOT noted that TPOs can extend service life of a bridge deck by 7 to 15 years but are not recommended on decks that have been exposed to chloride for more than 10 years or with an NBI rating less than 7 due to concerns of reflective cracking (Wisconsin Department of Transportation, 2019).

2.3.2.2. Premixed polymer concrete overlays (PPCO)

Currently, the most widely used polymer for mixer-blended polymer concrete overlays is polyester-styrene. While premixed polymer concrete overlays (specifically polyester polymer concrete - PPC) have been used successfully in California for over 30 years, their use in the Midwest have been relatively limited. PPC overlay thickness typically vary from 3/4-inch to 1-inch but thicker overlays are also common. PPC overlays are flexible and almost impermeable and can provide service life extensions of over 15 years, depending on the condition of underlying deck. PPC overlays can be open to traffic as soon as 2 to 4 hours after placement.

2.3.3. Asphalt Overlays

2.3.3.1. Hot-mixed asphalt (HMA) overlays

HMA overlays are typically not preferred by Midwest state DOTs as a long-term solution, but are more acceptable as a short-term solution. HMA overlays require shorter traffic closures and generally cost less than conventional PCC overlays. An HMA overlay with a properly installed waterproofing membrane may achieve a service life of over 10 years (Krauss, Lawler, & Steiner, 2009), but installation of the membrane will increase construction time and construction errors may result in leak of water through the membrane, leading to chloride ingress and corrosion of the deck reinforcement. A disadvantage of asphalt overlays is the inability to visually inspect the concrete deck, and, thus, severe corrosion in the deck may occur without being noticed. Another disadvantage of asphalt overlays is that they add deadload and they do not contribute to the structural capacity of the deck.

Asphalt overlays without a waterproofing membrane are generally not recommended for decks because deicer-laden water tends to be trapped between the overlay and concrete deck, which can accelerate chloride penetration into the deck or promote cyclic freezing damage. As short-term solutions, however, Michigan, Minnesota, and Wisconsin DOTs suggest the use of asphalt overlays without a membrane on decks planned to be replaced within less than 5 years. In these scenarios, Michigan and Minnesota DOTs do not require removal of deteriorated concrete before overlay placement, which can significantly reduce construction time.

2.3.3.2. Polymer-modified asphalt (PMA) overlays

Use of PMA overlays, which may be known by different names such as mastic asphalt and Rosphalt, has been relatively limited in the Midwest. They typically contain increased contents of asphalt binder and a polymer modifier such as styrene-butadiene-styrene (SBS) to make the overlay less permeable, and thus reporting that a waterproofing membrane is not needed. PMA overlays are expected to extend service life for 10 to 15 years. PMA overlays are quick to construct but expensive, and their performance has been inconsistent (Sprinkel & Apeageyi, 2013; Hunsucker, Ashurst, Rister, Allen, & Grady, 2018).

Table 2-2. Qualitative comparison between overlay types. A checkmark represents a relatively advantageous feature. A cross represents a relatively disadvantageous feature.

Characteristic	Hydraulic cement concrete						Polymer concrete		Asphalt		
	PCC	LSDC	HPC (SFC/MS)	UHPC	LMC	LMCVE	TPO	PPCO	HMA with WPM	HMA without WPM	PMA
Cost:											
Cost	x	x	x	x	x	x	✓	x	✓	✓	x
Performance/Service:											
Service life	✓	✓	✓	✓	✓	✓	x	✓	x	x	x
Access for deck inspection	✓	✓	✓	✓	✓	✓	x	x	x	x	x
Construction:											
Construction duration	x	x	x	x	x	✓	✓	✓	✓	✓	✓
Ability to accommodate grade variations	✓	✓	✓	✓	✓	✓	x	✓	x	✓	✓
Standard equipment	✓	✓	✓	x	x	x	x	x	✓	✓	✓
Sensitivity to ambient conditions:											
Moisture	✓	✓	✓	✓	✓	✓	x	x	✓	✓	✓
Temperature	✓	✓	✓	✓	✓	✓	x	x	✓	✓	✓

Table 2-3. Bridge Overlay Types Specified by State DOTs' Standard Specifications and Manuals

State	Hydraulic cement concrete					Polymer concrete		Asphalt Overlays		
	PCC	LSDC	HPC (SFC/MSC)	LMC	LMCVE	TPO	PPCO	HMA with WPM	HMA without WPM	PMA
Iowa		x	x ⁽¹⁾							
California							x			
Illinois	x		x	x		x		x		
Indiana			x	x			x			
Kansas	x					x				
Michigan			x	x				x ⁽²⁾	x ⁽³⁾	
Minnesota	x	x		x		x	x		x ⁽³⁾	
Missouri		x	x	x	x	x				
Nebraska	x		x			x		x		
New York	x		x							
North Dakota	x	x								
Ohio			x	x		x				
South Dakota		x		x						
Virginia	x		x	x	x	x		x		
Wisconsin		x				x ⁽²⁾	x	x ⁽²⁾	x ⁽³⁾	x ⁽²⁾
Total	8	6	8	8	2	8	4	5	3	1

Notes:

⁽¹⁾ The mix design for Iowa DOT typically includes Type IS or Type IP cement

⁽²⁾ Limited use

⁽³⁾ As short-term solutions only

2.4. Reinforced Overlays

As mentioned above, reinforced overlays are considered experimental and currently not specified in the standard specifications of any of the states in this review. Their general characteristics are discussed below for informational purposes.

2.4.1.1. Reinforced concrete (RC) overlays

RC overlays consist of a thick layer of concrete containing reinforcing steel. For example, Tennessee uses 4.5-inch thick RC overlays, particularly when the deck requires significant amounts of repair. These overlays are durable, but relatively costly and must be cured for at least 5 days (Egli, 2012). If repairs are not conducted prior to overlay installation, the overlay will continue to provide good ride quality but delamination will still occur, resulting in “floating” overlays.

2.4.1.2. Reinforced asphalt overlays

Reinforced asphalt overlays are more commonly discussed in pavement literature than bridge literature. Reinforcement for asphalt may consist of glass-reinforced products, geotextiles, polymeric grids, and steel mesh (Sanders, 2001). The reinforcement may be adhered to the underlying surface, either by a tack coat, an adhesive backing, or nails, or be located in the middle of the asphalt. Geotextile and glass-reinforced products have been relatively popular compared to steel meshes because they have more reliable performance. Geotextiles are considered particularly beneficial because they are embedded in thick tack coats which provide waterproofing properties. This shows that HMA overlays with waterproofing membranes for bridge decks may be considered as a subset of reinforced asphalt overlays. However, to our knowledge, alternative asphalt reinforcements that do not waterproof the surface have not been used in bridge deck overlays.

2.4.1.3. Fiber-reinforced concrete (FRC) overlays

FRC overlays may be considered a subset of HPC overlays and are included for completion in this section. FRC overlays contain fibers at about 0.2% vol to 1.0% vol (Amirkhanian & Roesler, 2019). The fibers are used to arrest cracks and improve post-cracking performance of the concrete. Fiber types include macrofibers and microfibers, and the fibers are typically either steel or synthetic. Fibers decrease workability and consistent fiber dispersion is challenging, but fibers improve the toughness and flexural properties of concrete. FRC has been extensively studied in laboratory testing and states such as South Dakota and Georgia have implemented field trials since the 1990s (Amirkhanian & Roesler, 2019; Barman, Hansen, & Arepalli, 2018). Iowa conducted a study beginning in 1974 that included an FRC overlay on a bridge deck (Betterton, Knutson, & Marks, 1984). Several states have begun requiring fibers in SFC overlays, and there have been limited cases where fibers have been incorporated in LMC overlays (Amirkhanian & Roesler, 2019). However, FRC overlay performance is still considered unproven and their use is limited.

2.4.1.4. Fiber-reinforced asphalt concrete (FRAC) overlays

Fibers may also be added to asphalt. They improve the adhesion between the asphalt binder and aggregates during placement and prevent segregation during installation and raveling during service (Park, 2012). The fibers added to asphalt are typically either asbestos, rook wool, or cellulose. Due to poor performance in the 1980s, FRAC was not investigated until a resurgence of interest in 2009 (Park, 2012). Studies completed

thus far have demonstrated that both fabric- and fiber-reinforced asphalt pavements have better resistance against reflective cracking in the field, but the benefits of this improved performance have been outweighed by increased installation costs (Park, 2012; McGhee, 1982).

CHAPTER 3. ANALYSIS OF CANDIDATES FOR LATE LIFE LOW COST OVERLAYS

This chapter presents a cost-benefit analysis of select overlay types based on the information obtained from the literature review. In addition, reduced surface preparation and construction procedures inspired by the Minnesota and Michigan DOTs' practices for late-life overlays are considered and compared with the lowa standard construction procedure. Based on the cost-benefit analysis, guidelines for selecting combinations of overlay material and construction procedure are provided. Finally, typical overlay details are presented. Specifications for the different overlays are provided in Appendix B.

3.1. Cost-Benefit Analysis

3.1.1. Overlay Types for Cost-Benefit Analysis

Based on the review of the current practices in Iowa, the Iowa DOT Class O concrete overlay, which typically has lower cost than Class HPC-O concrete, was selected as the baseline case for considering alternative options for late-life bridge deck overlays. The six unreinforced overlay systems listed below were selected for cost-benefit analysis. The basis for selecting those overlays are as follows:

- **LMCVE overlays** can reduce traffic impact due to their high early strength gain. Deck work can typically be completed during weekend closures.
- **Premixed polymer concrete overlays (PPCOs)** can significantly reduce traffic impact and can be installed during short night-time lane closures.
- **Thin polymer concrete overlays (TPOs)** can significantly reduce traffic impact and do not increase the deck surface elevation, thus avoiding the need to repair expansion joints and raise the approach pavement and rail.
- **HMA overlays with a waterproofing membrane (WPM)** can reduce traffic impact and provide protection to the deck from moisture and deicing salts.
- **HMA overlays without waterproofing membrane** can be used as a short-term solution that significantly reduces traffic impact and cost.
- **PMA overlays** can significantly reduce traffic impact.

Excluded from the analysis are PCC, HPC (SFC), LMC, and UHPC overlays. Although these hydraulic cement concrete overlays can provide significant service life extensions, they do not have particular advantages over Class O concrete overlays regarding traffic impact or construction costs, which are the top priorities for late-life applications.

Also excluded from the analysis are reinforced overlays because of the limited experience and information on their performance. In addition, reinforced concrete and fiber reinforced concrete overlays do not decrease traffic impact or construction costs compared with the Iowa DOT Class O concrete overlay.

3.1.2. Construction Procedures

The cost estimates were developed using a bottom-top procedure. The construction procedures assumed are discussed below. This section presents the general assumptions first, followed by a detailed description of the standard overlay construction procedure used by the Iowa DOT for Class O concrete, then the assumed adjustments to the standard procedure to accommodate the alternative overlay types under

consideration, and finally a reduced construction procedure based on experience of the Michigan and Minnesota DOTs is presented and discussed.

3.1.2.1. General Assumptions

It is assumed that the deck has an existing Iowa DOT Class O concrete overlay, which is typical for a deck in late life. Except when the new overlay is thin polymer concrete, the existing overlay (assumed to be 1 3/4-inch thick, Iowa standard concrete overlay) and an additional 1/4-inch concrete shall be removed and replaced with a new overlay 2 inches in thickness, resulting in no change in the driving surface elevation. For thin polymer concrete overlays, the surface is assumed to be shot blast, but the existing overlay will not be removed. Because the thin polymer concrete overlay is typically equal to or less than 1/2-inch in thickness, it can be feather-edged at joints and rails easily, and changes in the driving surface elevation and profile will be negligible. These assumptions avoid requiring modification of the expansions joints or raising of the bridge rail and approach slabs, which may incur significant costs.

For a deck without an existing overlay, joint and rail retrofits may or may not be avoidable. Without milling of the deck, polymer overlays can generally be tapered to a small thickness at the deck edges such that retrofitting is avoided. If 2 inches of concrete cover are present and can be removed, Class O, LMCVE, and PPCO overlays of 2-inch thickness can be installed without changing the driving surface elevation and the estimated overlay construction cost for decks with existing overlays will apply to decks without existing overlays. Since asphaltic overlays cannot replace concrete cover, their use on a deck without an existing overlay will typically increase the driving surface elevation, likely requiring joint and rail retrofits and significantly increasing the project cost and duration. Because of the different scenarios that could significantly affect cost estimates, decks without existing overlays (or equivalent 2 inches of cover that can be removed) are not considered in the cost-benefit analysis within this study.

3.1.2.2. Standard Procedures

Class O concrete overlay

The standard overlay construction procedure, based on Iowa DOT Standard Specifications Section 2413 for Interstate and Primary Projects, is described as follows.

1. Surface preparation for deck overlays:
 - a. Remove the existing overlay plus 1/4 inch.
 - b. After the deck is repaired as described below, prepare the surface for placement of new concrete by sandblasting or shot blasting, followed by an air blast.
2. Deck repair:
 - a. General:
 - i. Use a sounding technique to survey delamination in the deck and perform Class A deck repair as needed.
 - ii. Sandblast or shot blast all surfaces against which new concrete is to be placed, including curbs and exposed reinforcement.
 - iii. Thoroughly clean all reinforcing bars and newly exposed concrete by sandblasting or shot blasting. Where bond between existing concrete and reinforcing steel has been destroyed,

-
- remove the concrete adjacent to the bar to a depth that will permit new concrete to bond to the entire periphery of the exposed bar. A minimum of 3/4 inch clearance is required around the bar.
- iv. Clean the surface with an air blast immediately before applying grout in preparation for placement of new concrete.
- b. Class A Deck Repair:
 - i. Remove unsound concrete at least to the level of the top reinforcing bars by using a jack hammer, chipping hammer, shot blasting, hydro blasting, or by a combination of these.
 - ii. Concrete removal beneath reinforcing bars shall be accomplished using a 15-pound chipping hammer. Complete the final cleanup at the periphery and base of Class A repair using a 15-pound chipping hammer or hand tools.
 - iii. Place and cure concrete repair material: For Class O concrete overlay, Class O concrete shall be placed over the repair area monolithically with the overlay.
 - c. Class B Deck Repair:
 - i. Where needed, Class B deck repairs are to be completed as described in Iowa DOT Standard Specifications Section 2413. Further details are not included in this section as Class B repairs are not considered in the cost-benefit analysis.
3. Overlay placement and finishing:
 - a. After cleaning the surface and immediately before placing Class O concrete, scrub a thin coating of bonding grout into the dry, prepared surface.
 - b. Mix, place, consolidate, and screed concrete overlay to final grade.
 - c. Wet cure with wet-burlap and plastic sheet for 72 hours.
 4. Longitudinal grooving: perform longitudinal grooving on hardened concrete surfaces using a mechanical cutting device.

Other overlay types

The standard construction procedure for the other overlay types is similar to that for Class O concrete overlay with the following exceptions:

LMCVE overlays:

- For Class A Deck Repair, LMCVE is used and placed monolithically with the overlay.
- After being prepared and cleaned, the deck shall be thoroughly wetted for a minimum of 1 hour, then covered with PE sheeting until concrete placement. Surface must be damp with no standing water before overlay placement.
- Curing with wet burlap shall be applied promptly to the concrete overlay until the concrete is open to traffic.
- Curing time is at least 4 hours.

PPC overlays:

- Use PPC material for Class A Deck Repair and cure the repair for at least 4 hours before overlay placement.
- Prepare the deck using shot blasting, followed by an air blast after deck repair.
- The overlay can be open to traffic in typically 2 to 4 hours.

Thin (epoxy) polymer concrete overlays:

- Regarding surface preparation, the existing overlay shall not be removed; instead, the deck surface shall be prepared by shot blasting, followed by an air blast.
- For Class A Deck Repair, a rapid set concrete repair material shall be placed and cured for at least 4 hours before overlay placement.
- The thin epoxy polymer overlay shall be installed in two courses. For each course of overlay, polymer is applied to the deck, followed by broadcasting aggregate to completely cover the polymer. After the first course is cured, the second course is applied in a similar manner but at higher rates of polymer and aggregate.
- Curing time for the overlay depends on ambient temperature and varies between 4 hours and 12 hours.
- Longitudinal grooving is not performed for thin polymer overlays.

HMA overlays with a WPM:

- For Class A Deck Repair, a rapid set concrete repair material shall be placed and cured for at least 4 hours before overlay placement.
- After the deck is prepared and cleaned, a primer is applied to the surface.
- A waterproofing membrane is applied in two coats.
- A tack coat is applied to enhance bonding between the asphalt overlay and the waterproofing membrane.
- The HMA overlay is installed.
- Longitudinal grooving is not performed for asphalt overlays.

PMA and HMA overlays without a WPM:

- For Class A Deck Repair, a rapid set concrete repair material shall be placed and cured for at least 4 hours before overlay placement.
- After the deck is prepared and cleaned, the asphalt overlay is applied directly to the deck without installation of a waterproofing membrane.
- A tack coat is applied to enhance bonding between the asphalt overlay and the underlying surface.
- Longitudinal grooving is not performed for asphalt overlays.

3.1.2.3. Reduced procedure

In the reduced overlay construction procedure, the same steps as in the standard procedure are followed except that Class A Deck Repair including sounding, removal and placement of concrete within the repair

areas are not performed. Any apparently loose concrete, however, should be removed. Note that the reduced procedure still requires removal of the existing overlay (i.e., 2 inches of concrete) for several reasons. First, as discussed under General Assumptions, this prevents high costs associated with retrofitting joints, railings, and approach slabs to the new surface elevation. Second, for polymeric overlays which may be tapered such that the first point is not a concern, removal of chloride-contaminated and/or deteriorated concrete in the upper 2 inches provides better service life for relatively low cost. The benefit of the longer service life is likely to outweigh the cost of milling 2 inches of concrete. The primary benefit of the reduced procedure is that removal of concrete to depths past the top mat of rebar by methods such as hand chipping, which is the most time- and labor-intensive step as shown by the costs listed in Table 3-3, is not required.

The reduced procedure is based on a practice used by Minnesota and Michigan DOTs in which a concrete or asphalt overlay is placed on a deck surface that has been scarified to improve bonding, but removal of the deteriorated concrete is not required. This can significantly reduce construction cost and time but will also decrease service life of the overlay. In this study, service life of an overlay using the reduced procedure is hypothetically assumed to be 50% of that using the standard procedure unless other information is available from the literature.

Thin polymer concrete overlays are not suitable for the reduced procedure because the small thickness of the overlay is unlikely to prevent the surface manifestation of future spalling or accommodate the grade differences of existing spalls where the deteriorated concrete is not repaired.

3.1.3. Deck Condition

Deck geometry and condition used for cost analysis is presented in Table 3-1. The cost and duration are estimated for a one-lane overlay since the number of lanes does not affect relative comparison between different overlay systems. It is assumed that for multiple lane decks, one lane is closed at a time for overlay installation, and thus the total cost and time can be estimated by multiplying corresponding values for one lane with the number of lanes. It is assumed that the deck has an existing overlay, as discussed in Section 3.1.2. The area of delaminated concrete that needs Class A Deck Repair (partial depth repair) is assumed to be 20% of the deck area, a representative condition of a deck at late life. Class B Deck Repair (full depth repair) is not considered in the cost-benefit comparison. When Class B Deck Repairs are identified by visual inspection of the deck underside, they should be included in the overlay project regardless of the overlay type or construction procedure.

Table 3-1. Deck Condition

Lane width (ft)	12
Overlay length (yd)	100
Overlay area (yd)	400
Class A Deck Repair, 20% of deck area (sy)	80

3.1.4. Construction duration

Based on the construction procedures described in Section 3.1.2, construction durations for different overlay types have been estimated and given in Table 3-2. If the standard procedure is used, the estimated construction durations including concrete removal, deck repair, surface preparation and overlay installation

and curing are 6 days for Class O concrete, and 3 days for the other overlay types. It is noted that these duration estimates, except for the Class O concrete overlay, are conservative and could likely be shortened to one weekend with night work. If a reduced procedure is used, the durations are estimated to decrease by approximately 1 day for all the overlay types.

Table 3-2. Estimated Construction Durations (days) for Different Overlay Types and Procedures

Construction Procedure	Class O	LMC-VE	PPC	TPO	HMA WPM	HMA	PMA
Standard	6	3	3	3	3	3	3
Reduced	5	2	2	--[1]--	2	2	2

Note: ^[1] Thin polymer concrete overlays are not applicable for the reduced procedure

3.1.5. Cost Estimate

Costs of different overlays and associated works are presented in Table 3-3, along with the source of the estimated cost. Note that traffic control and mobilization costs are excluded. Based on the costs in Table 3-3, construction costs for different types of overlays are presented in Table 3-4 and Table 3-5, respectively for standard and reduced procedures.

Table 3-3. Unit Costs of Overlays (Materials and Installation) and Associated Tasks

Item	Unit	Unit cost (\$)	Source
Overlays			
Class O PCC, 2" thick	SY	60.13	Iowa DOT
LMC-VE, 2" thick	SY	153.90	Virginia DOT
PPCO, 2" thick	SY	145.52	Caltrans
Thin epoxy polymer concrete, 1/4 - 3/8" thick	SY	39.33	Nebraska DOT
HMA (2" thick) with WPM	SY	49.50	Michigan DOT
HMA (2" thick) without WPM	SY	13.50	Michigan DOT
PMA (2" thick) without WPM	SY	98.28	Wisconsin DOT
Associated Tasks			
Removal of existing overlay	SY	14.62	Iowa DOT
Surface preparation using abrasive blasting	SY	4.40	South Dakota DOT
Partial-depth deck repair (Class A)	SY	196.91	Iowa DOT
Longitudinal grooving	SY	2.97	Iowa DOT

Table 3-4. Estimated Overlay Costs - Standard procedure

Item	Unit	Quant.	Unit Cost (\$)							Total Cost (\$)						
			Class O	LMC-VE	PPC	TPO	HMA - WPM	HMA	PMA	Class O	LMC-VE	PPC	TPO	HMA - WPM	HMA	PMA
Concrete Removal	SY	400	14.62	14.62	14.62	0.00	14.62	14.62	14.62	5,848	5,848	5,848	-	5,848	5,848	5,848
Surface prep	SY	400	4.40	4.40	4.40	4.40	4.40	4.40	4.40	1,760	1,760	1,760	1,760	1,760	1,760	1,760
Deck Repair, Class A	SY	80	196.91	196.91	196.91	196.91	196.91	196.91	196.91	15,753	15,753	15,753	15,753	15,753	15,753	15,753
Deck Overlay	SY	400	60.13	123.67	145.52	39.33	49.50	13.50	98.28	24,052	49,468	58,206	15,732	19,800	5,400	39,310
Grooving	SY	400	2.97	2.97	2.97					1,188	1,188	1,188	-	-	-	-
Total										48,601	74,017	82,755	33,245	43,161	28,761	62,671
Total cost per SY overlay (\$/SY)										122	185	207	83	108	72	157

Table 3-5. Estimated Overlay Costs - Reduced Procedure

Item	Unit	Quant.	Unit Cost (\$)							Total Cost (\$)						
			Class O	LMC-VE	PPC	TPO	HMA - WPM	HMA	PMA	Class O	LMC-VE	PPC	TPO	HMA - WPM	HMA	PMA
Concrete Removal	SY	400	14.62	14.62	14.62	N/A	14.62	14.62	14.62	5,848	5,848	5,848	N/A	5,848	5,848	5,848
Surface prep	SY	400	4.40	4.40	4.40	N/A	4.40	4.40	4.40	1,760	1,760	1,760	N/A	1,760	1,760	1,760
Deck Overlay	SY	400	60.13	123.67	145.52	N/A	49.50	13.50	98.28	24,052	49,468	58,206	N/A	19,800	5,400	39,310
Grooving	SY	400	2.97	2.97	2.97	N/A				1,188	1,188	1,188	N/A	-	-	-
Total										32,848	58,264	67,002	N/A	27,408	13,008	46,918
Total cost per SY overlay (\$/SY)										82	146	168	N/A	69	33	117

3.1.6. Cost-Benefit Comparison and Discussion

The baseline for comparison is Class O concrete overlay using standard construction procedure, which is a standard practice in Iowa. Costs, in terms of economic costs to the agency, and benefits, in terms of service life and reduced traffic closure, of the other overlay options are compared with the baseline. The results are presented in Table 3-6 and Table 3-7. Expected service life for different overlay types using the standard procedure have been obtained from the literature and are noted on Table 3-6. Expected service life for overlays using the reduced procedure is hypothetically assumed to be approximately half of those for standard procedure unless otherwise noted on Table 3-7.

3.1.6.1. Standard construction procedure

All the overlay options evaluated can reduce traffic closure periods compared with the baseline by about half the time required for a standard Class O overlay. In addition, thin polymer concrete and HMA overlays with or without a WPM can reduce the cost by approximately 10 to 40%. It should be noted, however, that the lower-cost options tend to have shorter service lives. For example, HMA overlay without a WPM can reduce the cost by approximately 40%, but the expected service life would be only 3 to 7 years.

3.1.6.2. Reduced construction procedure

Using the reduced procedure, more overlay options with lower cost and shorter traffic closure are available as shown in Table 3-7. Comparison of Different Overlay Systems - Reduced Construction Procedure, which could be attractive for a late life deck with limited remaining service life. For example, HMA overlays with or without a WPM can reduce the cost by approximately 40 to 70% compared to the baseline. It is worth noting, however, the practice of overlay without removing deteriorated concrete is not as common as the standard procedure, and overlay performance record has not been established. Furthermore, service life of the overlay would likely be dependent on the quantity of deteriorated concrete present in the deck. Thus, the optimal overlay should be selected with engineering judgement considering the deck condition and the risk that the overlay may fail before replacement work can be started, in addition to cost and impact of traffic closures.

3.2. Selection of overlay solutions for late-life deck

For bridges considered for replacement, service life is no longer the priority, and may be reduced depending on the replacement schedule. With the reduced service life requirement, other overlay options are available with lower costs and lower traffic impact than the standard Iowa Class O concrete overlay. To assist selection of overlays for different bridge replacement schedules, service life has been divided into three categories: short (4 years or less), medium (5 to 10 years), and long (10 to 15 years); for each category appropriate overlay options are marked, and their cost and traffic impact are shown in Table 3-8. An overlay option is considered appropriate for a certain service life category if its lower-bound expected service life (as presented in Table 3-6 and Table 3-7) is within the service life range of that category. Based on Table 3-8, overlay options appropriate for each service life category can be selected as follows:

- For a bridge scheduled for replacement within less than 5 years, an HMA overlay without a WPM using the reduced procedure is the optimal option in terms of both cost and traffic impact. If it is desirable to reduce the potential that the overlay fails before funding is available for bridge replacement, an HMA overlay with a WPM may be considered. Hot mix asphalt overlays without a membrane have the

disadvantage of trapping water and deicers on the deck surface and increasing the typical moisture content within the deck concrete. This can lead to accelerated corrosion of the deck and make concrete more susceptible to damage due to cyclic freezing. The membrane reduces these negative effects. Traffic loading and speeds should also be considered as, if not properly designed and installed, HMA overlays can be prone to rutting or shoving. Therefore, they may be best suited for bridges on secondary roads. For main road and interstate bridges, a Class O concrete overlay using the reduced procedure or a thin polymer overlay using the standard procedure may be more suitable. However, the thin polymer overlay provides significant traffic closure savings.

- For a bridge scheduled for replacement in 5 to 10 years, either an HMA overlay with a WPM using the reduced procedure or a thin polymer concrete overlay using the standard procedure are reasonable options. If the deck condition is fair or better, the thin polymer overlay is more attractive because it has lower cost, traffic impact, and weight. But if the deck condition is poor, the HMA overlay with a WPM may be a better option because it can accommodate larger variations in grades and is more resistant to reflective cracking. As stated above, HMA overlays can be prone to rutting or shoving and, therefore, they may be best suited for bridges on secondary roads. If traffic closure time is not an issue, a Class O concrete overlay using the reduced procedure may also be used.
- For a bridge scheduled for replacement in 10 to 15 years, a Class O concrete overlay using the reduced procedure is the lowest-cost option. However, an LMCVE, PPCO, or PMA overlay or an HMA overlay with a WPM may decrease the traffic closure time by about 50%. An HMA overlay with a WPM (standard procedure) is the most cost-effective of the set of overlays with shortened construction durations. As stated above, HMA overlays can be prone to rutting or shoving and, therefore, they may be best suited for bridges on secondary roads.

Table 3-6. Comparison of Different Overlay Systems - Standard Construction Procedure

Overlay Type	Criteria			Differences from Baseline ^[1]		
	Cost (\$/SY)	Construction time (days)	Service life (years)	Cost	Construction time (days)	Service life
Class O (Baseline)	122	6	16 - 32 ^[2]	0%	0.0	↔
LMCVE	185	3	14 - 29 ^[2]	52%	-3.0	↔
PPCO	207	3	20 - 30 ^[3]	70%	-3.0	↔
Thin polymer concrete	83	3	7 - 15 ^[2]	-32%	-3.0	↓↓
HMA with WPM	108	3	12 - 19 ^[2]	-11%	-3.0	↓
HMA w/o a WPM	72	3	3 - 7 ^[3]	-41%	-3.0	↓↓↓
PMA	157	3	10 - 15 ^[3]	29%	-3.0	↓

Notes:

^[1] Baseline is Class O concrete overlay using standard procedure

^[2] Krauss et al., 2009

^[3] WisDOT Bridge Manual

Table 3-7. Comparison of Different Overlay Systems - Reduced Construction Procedure

Overlay Type ^[1]	Criteria			Differences from Baseline ^[2]		
	Cost (\$/SY)	Construction time (days)	Service life (years)	Cost	Construction time (days)	Service life
Class O	82	5	10 - 15 ^[3]	-32%	-1.0	↓↓
LMCVE	146	2	7 - 15 ^[4]	20%	-4.0	↓↓
PPCO	168	2	5 - 10 ^[6]	38%	-4.0	↓↓
HMA with WPM	69	2	6 - 8 ^[4]	-44%	-4.0	↓↓↓
HMA w/o a WPM	33	2	2 - 4 ^[5]	-73%	-4.0	↓↓↓
PMA	117	2	5 - 8 ^[4]	-3%	-4.0	↓↓↓

Notes:

^[1] Reduced construction procedure is not applicable for thin polymer concrete overlays.

^[2] Baseline is Class O concrete overlay using standard procedure

^[3] MnDOT Bridge Design Manual

^[4] Assume 50% service life reduction compared to standard procedure

^[5] Michigan DOT Bridge Design Manual

^[6] WJE experience

Table 3-8. Selection of Overlays for Different Service Life Categories

Required Service Life ^[1]			Cost ^[2] (\$/SY)	Traffic closure ^[2] (days)	Overlay Materials	Procedure
Short (SL < 5)	Medium (5 ≤ SL < 10)	Long (10 ≤ SL < 15)				
✓	✓	✓	122	6	Class O	Standard
✓	✓	✓	185	3	LMCVE	
✓	✓	✓	207	3	PPCO	
✓	✓	✗	83	3	Thin polymer concrete	
✓	✓	✓	108	3	HMA with WPM	
✓	✗	✗	72	3	HMA w/o a WPM	
✓	✓	✓	157	3	PMA	
✓	✓	✓	82	5	Class O	
✓	✓	✗	146	2	LMCVE	Reduced
✓	✓	✗	168	2	PPCO	
✓	✓	✗	69	2	HMA with WPM	
✓	✗	✗	33	2	HMA w/o a WPM	
✓	✓	✗	117	2	PMA	

Notes:

^[1] A tick mark (✓) indicates the overlay option is applicable for the service life category; a cross (✗) indicates the opposite.

^[2] Color scale indicates variations in cost and traffic closure among the overlay options.

3.3. Sensitivity of Cost to Repair Area

The cost-benefit analysis presented in Sections 3.1 and 3.2 was developed using the assumptions described in Section 3.1.3 that the quantity of Class A deck repair is 20 percent of the deck area. It was shown in Table 3-7 that several overlay options using the reduced construction procedure, which excludes Class A deck repairs, can reduce the cost by up to approximately 70% compared to the baseline. The percentage of cost reduction will vary with the percent of deck area requiring Class A repairs. In this section, percent of deck area requiring Class A repairs is varied from 0% to 50% (very high assumption) to evaluate the sensitivity of the cost to the deck repair area.

Figure 3-1 shows the percent difference in cost from the baseline scenario (a Class O overlay using standard installation procedure) for each combination of overlay type and procedure included in this analysis as a function of the percentage of the deck area requiring Class A repairs. The abbreviation "Std" represents the standard procedure and the abbreviation "Red" represents the reduced procedure. At zero percent repair area, the cost of the standard procedure is equal to the cost of the reduced procedure for each overlay type. The costs of the overlays using the standard procedure come closer to the cost of the baseline overlay with increasing deck distress. The costs of the overlays using the reduced procedure decrease in relationship to the standard procedure as the percent area of deck distress increases.

LMCVE (Std), PPCO (Std), and PMA (Std) overlays always have costs at least 20% greater than the baseline cost. At repair areas of approximately 18%, 32%, and 43%, PMA (Red), LMCVE (Red), and PPCO (Red) overlays, respectively, become less expensive than the baseline overlay; but they would also be expected to have less life. The TPO, HMA with WPM, and HMA without WPM overlays are less expensive than the baseline overlay regardless of the repair area and construction procedure.

To compare the costs of overlay options appropriate for different service life categories, the percent cost savings are plotted in bar graphs in Figure 3-2 for overlay options expected to provide between 5 and 10 years of service life and in Figure 3-3 for those expected to provide at least 10 years of service life. These graphs demonstrate the cost rankings and how they change with repair area. Instances where the ranking between options changes are circled. A similar graph for overlay options expected to provide a service life of less than 5 years is not presented since it would only show HMA overlays without WPM using either standard or reduced procedure, and the ranking does not change with the repair area.

As demonstrated by Figure 3-2 and Figure 3-3, the ranking is only somewhat sensitive to the repair area. Among overlays capable of providing between 5 and 10 years of additional service, the TPO (Std) overlay is initially the least expensive option until about 7% of area requires repairs. The HMA w/ WPM (Red) overlay then becomes the least expensive option for up to the 50% repair area. Class O concrete (Red) and PMA (Red) overlays become less expensive than TPO (Std) at approximately 30% and 44%, respectively.

Among overlays capable of providing 10 to 15 years of additional service life, the HMA w/ WPM (Std) is the least expensive option until 7% of the deck area requires repairs at which point Class O (Red) overlay becomes the least expensive option. Otherwise, the ranking remains the same for up to 50% of repair area.

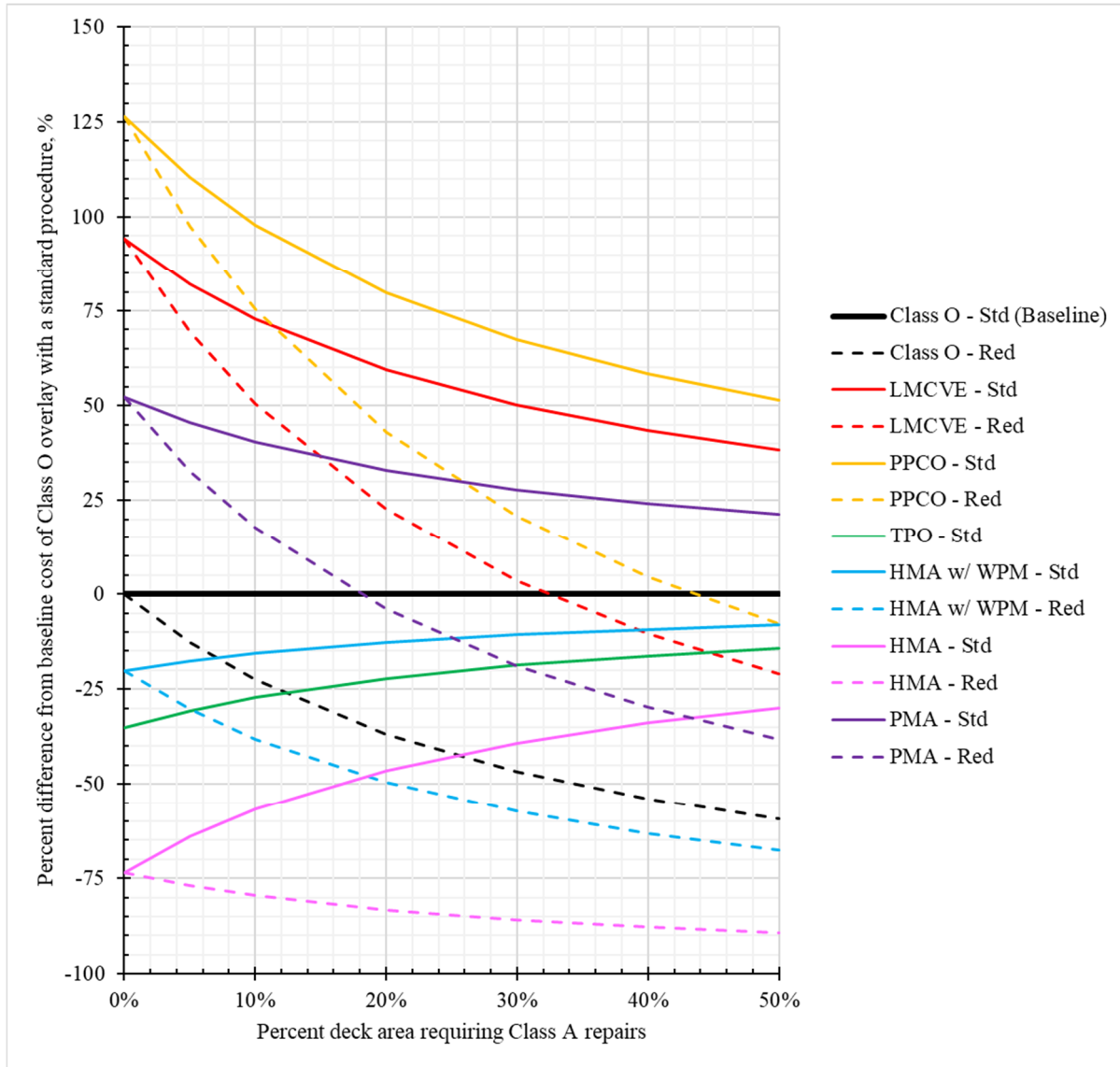

Figure 3-1. Plot showing how the percent difference in cost between each overlay and the baseline overlay varies with the percent of deck area requiring Class A repairs. Solid lines indicate overlays using standard procedure. Dotted lines indicate overlays using reduced procedure.

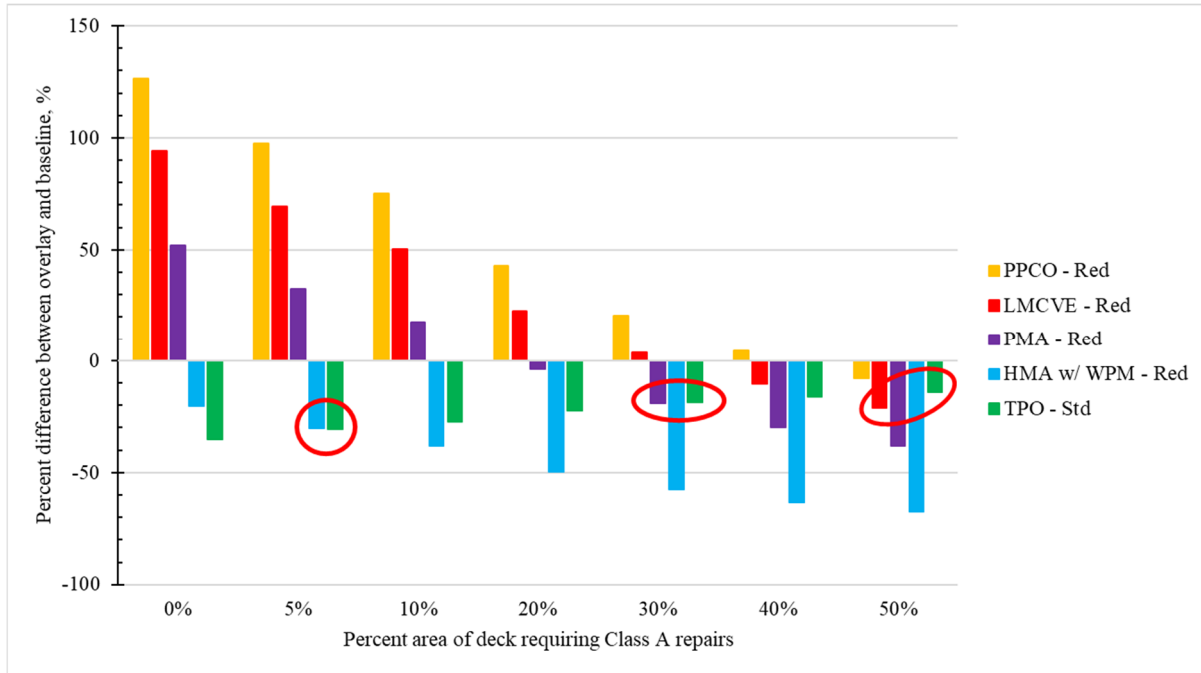

Figure 3-2. Bar graph showing cost ranking of overlays that are assumed to be capable of providing between 5 and 10 years of additional service varies with the percent of the deck area requiring Class A repairs. Any changes in ranking are circled. (Note: overlays capable of providing more than 10 years of additional service are not shown in this graph)

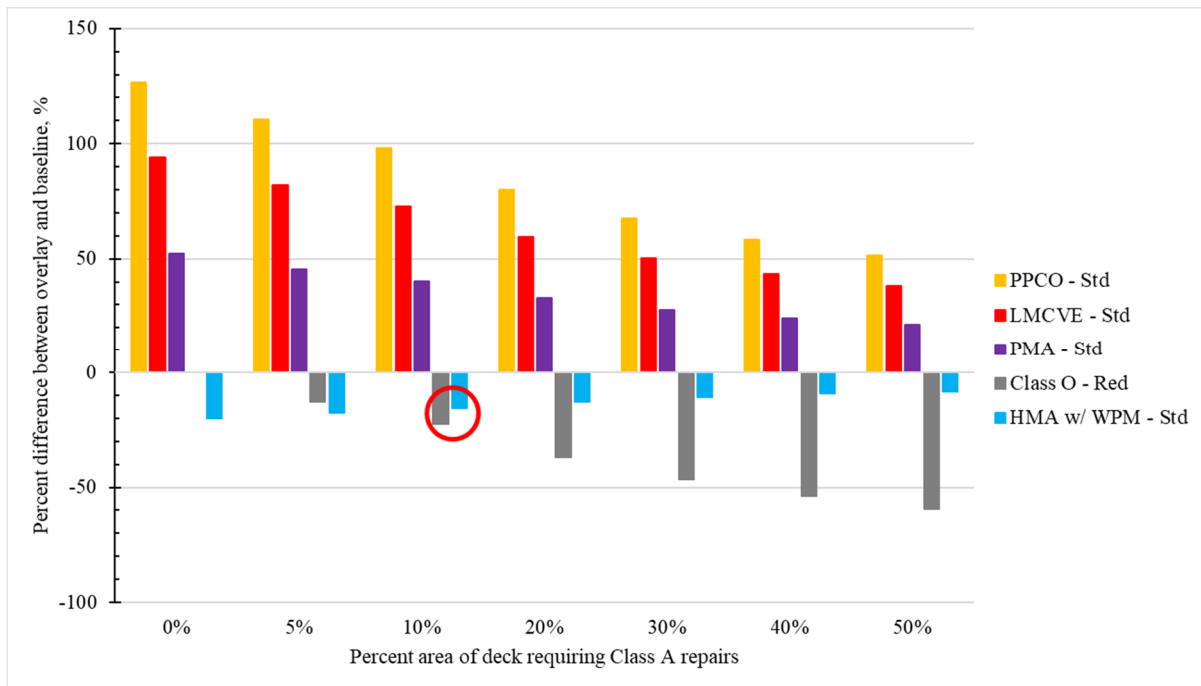

Figure 3-3. Bar graph showing cost ranking of overlays that are assumed to be capable of providing between 10 and 15 years of additional service varies with the percent of the deck area requiring Class A repairs. Any changes in ranking are circled.

3.4. Standard Details and Specifications for Overlay Candidates

Standard details for a thin polymer concrete overlay using the standard procedure is presented in Figure 3-4. Because of the small thickness, this type of overlay can be feather-edged at expansion joints and thus does not require repair of the expansion joint headers. Standard details for all the other overlays at a typical location along the bridge deck are presented in Figure 3-5 for standard procedure (a) and reduced procedure (b). In both procedures, the existing overlay and an additional 1/4-inch concrete shall be removed. Since the new overlay shall have the same thickness as the removed concrete, there will be no change in the surface riding elevation. In the standard procedure, Class A and Class B repair areas shall be identified and concrete surface in those areas shall be prepared in accordance with Iowa Standard Specifications, Section 2413. In the reduced procedure, there will be no Class A repair. Repair of Class B repairs should still be considered even if the reduced procedure is selected due to the high potential of damage in these areas.

Standard details for concrete and PPCO overlays at an expansion joint for standard and reduced procedures are presented in Figure 3-6 (a) and (b), respectively. In the standard procedure, Class A repair over a length of 2 feet from the joint shall be performed. This 2-foot Class A repair may not be performed in the reduced procedure.

Standard details for asphalt overlays at an expansion joint for standard and reduced procedures are presented in Figure 3-7 (a) and (b), respectively. In the standard procedure, Class A repair over a length of 2 feet from the joint shall be performed before placement of the overlay. In the reduced procedure, 2 feet of existing deck from the joint may remain, assuming it is in adequate condition, to provide edge support for the asphalt overlay.

Specifications for different overlay types are documented and provided in Appendix B.

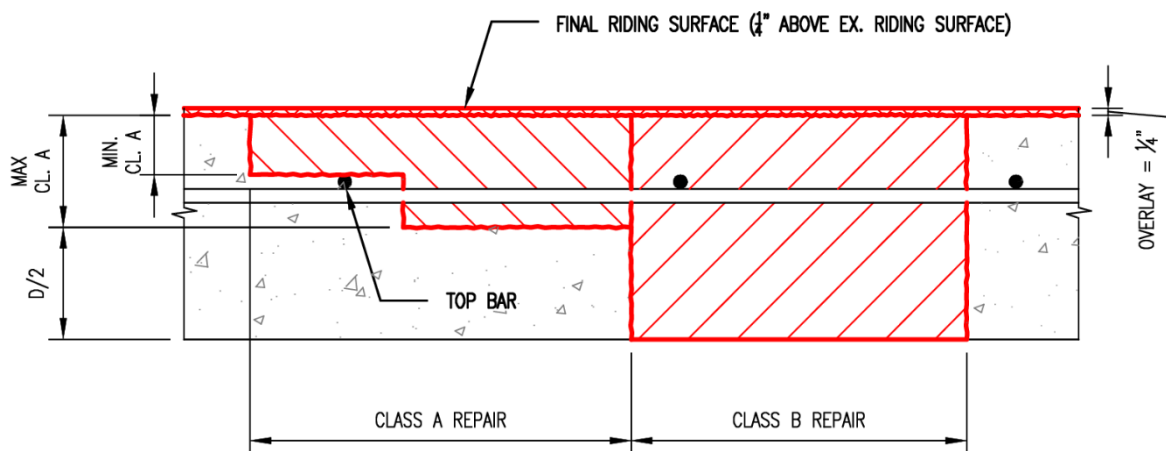
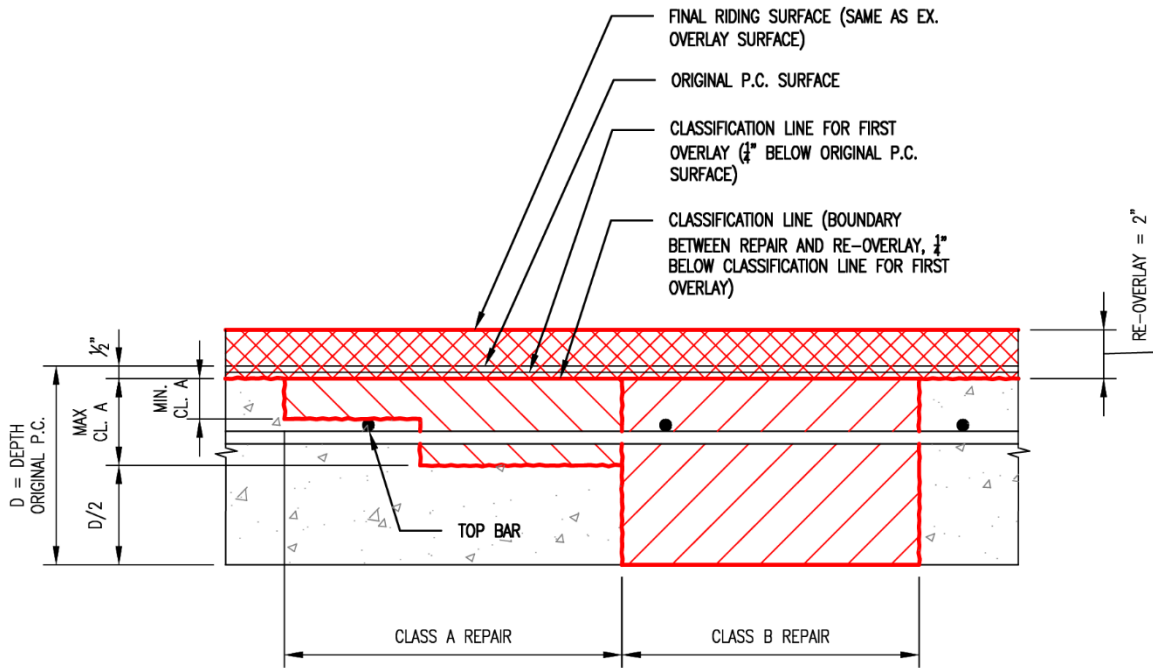
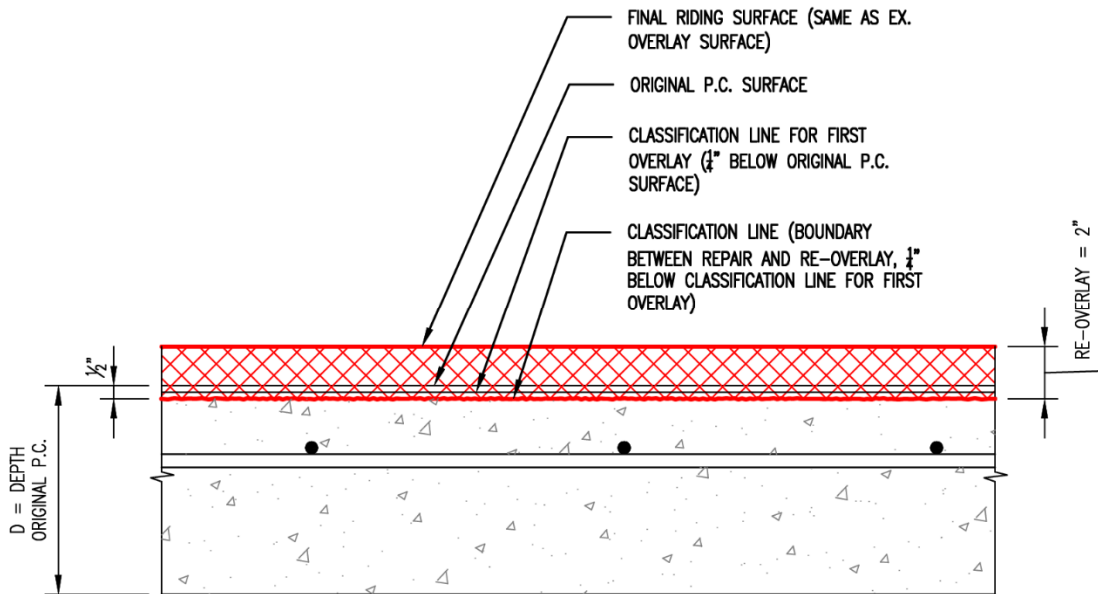

Figure 3-4. TPO, longitudinal section at a typical location along roadway (section at joint similar)



(a) Standard procedure



(b) Reduced procedure

Figure 3-5. All overlay types except TPO, longitudinal section at a typical location along roadway

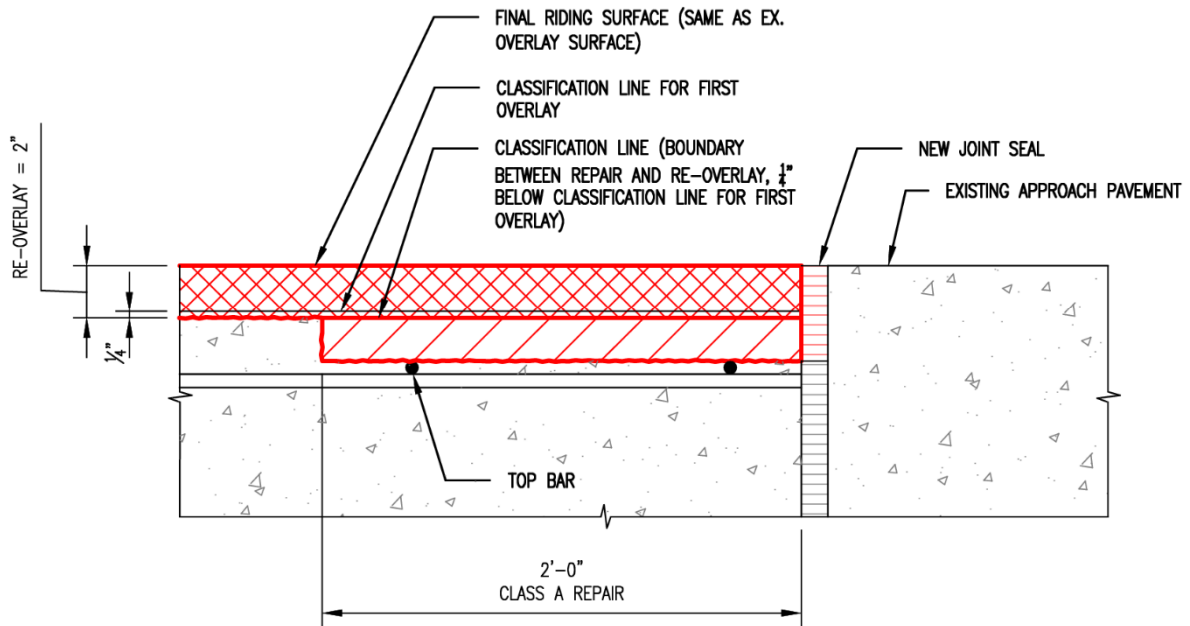

(a) Standard procedure

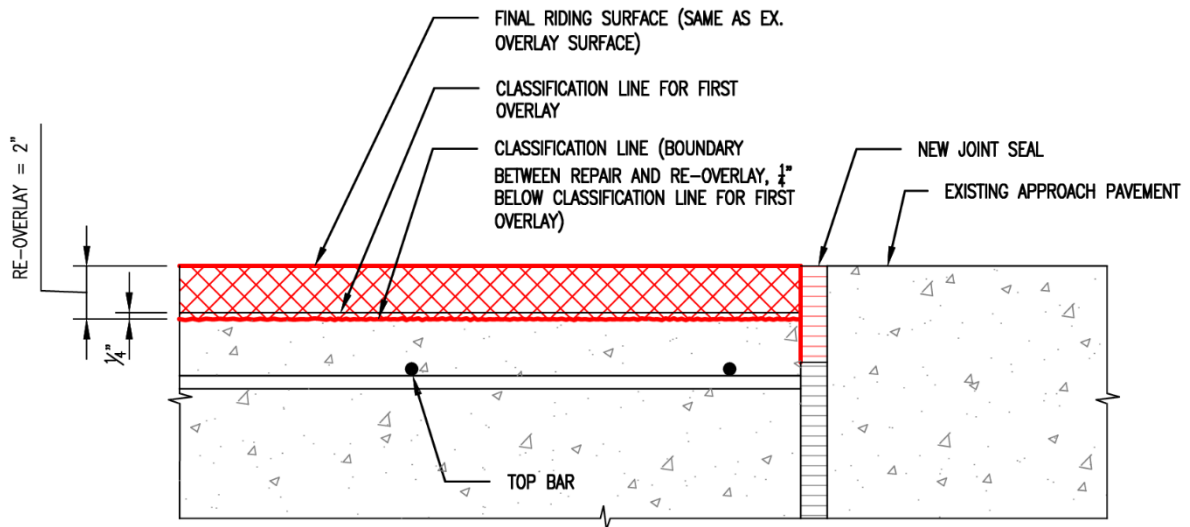

(b) Reduced procedure

Figure 3-6. Concrete and PPCO overlays, longitudinal section at joint

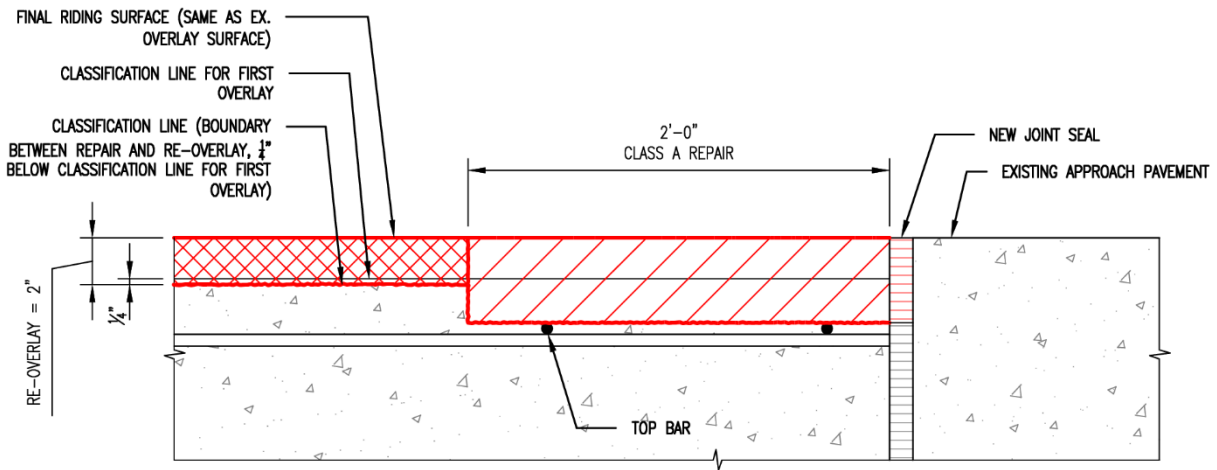

(a) Standard procedure

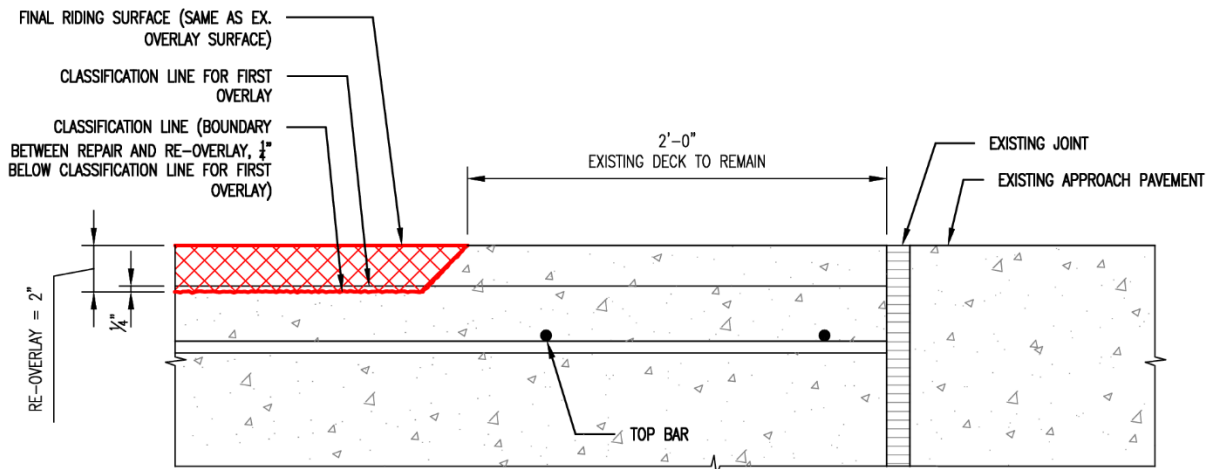

(b) Reduced procedure

Figure 3-7. HMA and PMA overlays, longitudinal section at joint

CHAPTER 4. CONCLUSIONS AND RECOMMENDATIONS

4.1. Summary and Conclusions

Late-life bridge decks often require an overlay to restore their riding surface and prevent their service life from ending before their scheduled time of replacement. In these scenarios, an overlay that is inexpensive, minimally interrupts traffic, and provides the minimum, reduced service life extension is desirable. The Iowa DOT currently uses low-slump, PCC overlays for bridge deck overlays and requires any delaminated or unsound area be repaired. A literature review and cost-benefit analysis were conducted in order to identify overlays that provide short durations of service life extension on late-life bridge decks that are relatively cost-effective and require shorter construction times than standard Class O overlays.

In the literature review, ten types of unreinforced overlays were identified: PCC, LSDC, HPC, LMC, LMCVE, PPCO, TPO, HMA with WPM, HMA without WPM, and PMA. Several reinforced overlays were also identified and briefly discussed, but not included in the cost-benefit analysis due to their relative rarity of use. The standard practices of fourteen states (California, Illinois, Indiana, Kansas, Michigan, Minnesota, Missouri, Nebraska, New York, North Dakota, Ohio, South Dakota, Virginia, and Wisconsin) were reviewed for comparison against the standards used in Iowa. The review revealed that there was little documentation of the age and condition of the bridge decks being overlaid. Only the Illinois, Wisconsin, Michigan, and Minnesota DOTs discussed late-life applications. All four stated that HMA overlays without waterproofing membranes were acceptable short-term solutions for service life extension at the end of the life of the bridge deck if replacement was scheduled for within 5 years. Minnesota and Michigan DOT bridge manuals stated that removal of deteriorated concrete before overlay placement, accepted as best practice, is not necessary for decks with such a limited remaining service life. Specifically, the Minnesota DOT noted that concrete overlays with a thickness of up to 3 inches without removing deteriorated concrete can be expected to provide up to 10 to 15 years of service life. The omission of deck repair not only reduces the cost of the overlay, but also the construction time.

Based on findings from the literature review, seven types of overlays (Class O overlays, considered as the baseline; LMCVE overlays; PPC overlays; thin polymer overlays; HMA overlays with WPM; HMA overlays without WPM; and PMA overlays) were selected for the cost-benefit analysis. The selected overlays can significantly reduce traffic impact compared with the baseline Class O concrete overlay. Two construction procedures were analyzed. The first is a standard procedure consisting of surface preparation of the deck including partial-depth repairs and then overlay installation and finishing. The second is a reduced procedure similar to the standard procedure except omitting partial-depth repairs. For comparison between the standard and reduced procedures, 20% of the deck area was assumed to require partial-depth repairs. The reduced procedure was shown to be able to significantly reduce the construction cost. When the reduced procedure was used, the service life was assumed to be half of the life reported for overlays installed using best practices (i.e. removing deteriorated and chloride-contaminated concrete from around the rebar and patching the deck prior to overlay installation). It should be noted that the use of LMCVE, PPCO, PMA, and HMA with a WPM combined with the reduced procedure has not been reported in the literature, and thus the service life ranges for these three combinations assumed in the cost-benefit analysis were hypothetical in nature.

All the late-life overlays had trade-offs between service life, cost, and construction time such that no single overlay performed best in all those three categories. For a bridge scheduled for replacement within 5 years, an HMA overlay without a WPM, installed by the reduced procedure, was found to be least expensive. For a bridge scheduled for replacement in 5 to 10 years, an HMA overlay with a WPM, installed by the reduced procedure, provided the lowest cost. Finally, for a bridge scheduled for replacement in 10 to 15 years, the Class O PCC overlays, installed by the reduced and standard procedures, had the lowest costs but the longest closure times. Increased deck distress and subsequent repair area was found to affect the cost ranking minimally.

When selecting an overlay, factors beyond those included in this analysis need to be taken into consideration as well. HMA overlays with or without WPM can be susceptible to damage due to high traffic loadings, particularly when located in a decelerating or accelerating area. Thin polymer overlays are not capable of reprofiling a surface and improving its ride quality, and, therefore, can only be installed using the standard procedure and may not be suitable if the deck suffers poor ride quality. They are also unlikely to prevent future delaminations from manifesting potholes on the deck surface. Further, local contractor experience and the time of year can limit some overlay options. These are project-specific circumstances that need to be considered on a case-by-case basis.

The conclusions drawn from this study are as follows:

1. There is a literature gap regarding the installation and performance of overlays applied late in the life of bridge decks.
2. HMA overlays with WPM, HMA overlays without WPM, and thin polymer overlays (Standard Procedure) are cost-competitive compared to Class O PPC overlays.
3. LMCVE, PPCO, thin polymer overlays, HMA overlays with WPM, HMA overlays without WPM, and PMA overlays can be suitable options for bridges allowing only short traffic closures because they have a smaller traffic impact than the Class O PPC overlays used by the Iowa DOT.
4. Amending the standard construction procedure for late-life overlays such that partial-depth (Class A) repairs are not required produces overlays that have reduced costs and construction time, but may still be capable of providing the required service life extension until the deck is replaced.

As a result of this study, Table 3-8 was developed as a summary table that may be used as a decision-making tool for selecting an overlay based on cost, construction time, and required service life. Examples of standard details and specifications for the late-life overlays are provided in Section 3.4 and Appendix B.

4.2. Recommendations

Based on the conclusions of this study, the following is recommended:

1. Based on the experiences of the Michigan and Minnesota DOTs, a reduced construction procedure that limits or fully excludes Class A repairs may be implemented exclusively for late-life overlay installations to reduce costs and construction time. A field study is recommended to confirm the feasible service life of overlays constructed using this new procedure, as well as to demonstrate construction time and cost benefits.

-
2. We recommend that a cost-benefit analysis similar to that presented in this study but with more refinement be performed for several bridges with varying deck conditions and service life requirements to confirm the costs and economic benefits predicted in this report.
 3. HMA overlays with waterproofing membranes are less expensive than PCC overlays, and can be installed quickly. Although these overlays are typically not used in Iowa due to concerns over long-term performance, they may be considered for late life decks with short or medium remaining service life. Specifications and local contractor expertise in HMA overlays with waterproofing membranes can be developed based on specifications and experiences from states where HMA with waterproofing membranes have been used successfully such as Nebraska and Maine.
 4. Reinforced asphalt overlays (other than HMA overlays with waterproofing membranes) are expected to provide longer service life than HMA overlays, and may also be investigated as potential late-life overlays in a trial field study. The purpose of the trial study would be to determine whether reinforced asphalt overlays are worth pursuing by comparing the service life, ease of installation, and cost of these overlays with HMA overlays and HMA overlays with waterproofing membranes.

4.3. Implementation

The contents of this report may be used to update or revise Iowa DOT construction procedures and specifications for bridge deck overlays on late-life bridges with limited service life extension requirements. The cost-benefit analysis results and associated tables can be used as a decision-making tool for selecting a late-life overlay based on cost, construction time, and required service life. The specifications and details compiled in the report can be used by Iowa DOT for developing final special provisions for the recommended overlay system(s), as well as for reference during future trial applications.

BIBLIOGRAPHY

- Amirkhanian, A., & Roesler, J. (2019). Overview of Fiber-Reinforced Concrete Bridge Decks. Ames, IA: Iowa Department of Transportation.
- Anderson, K. W., Uhlmeier, J. S., Russell, M., Simonson, C., Littleton, K., McKernan, D., & Weston, J. (2019). Polyester Polymer Concrete Overlay Final Report. Olympia, WA: Washington State Department of Transportation.
- Balakumaran, S. S., Weyers, R. E., & Brown, M. C. (2017). Performance of Bridge Deck Overlays in Virginia: Phase I: State of Overlays. Richmond, VA: Virginia Department of Transportation.
- Barman, M., Hansen, B., & Arepalli, U. (2018). Performance Benefits of Fiber-reinforced Thin Concrete Pavement and Overlays Task-1: Literature Review. Duluth, MN: Minnesota Department of Transportation.
- Betterton, R. M., Knutson, M. J., & Marks, V. J. (1984). A Ten Year Performance Summary of Fibrous P.C. Concrete Overlay Research in Greene County, Iowa. Ames, IA: Iowa Department of Transportation.
- Bridge Division. (2016). Bridge Office Policies and Procedures. Nebraska Department of Roads.
- Bridge Office. (2015). Fiscal Year 2016 through 2020 Bridge Preservation and Improvement Guidelines. St. Paul, MN: Minnesota Department of Transportation.
- Bureau of Bridges and Structures. (2011). Bridge Condition Report Procedures and Practices. Springfield, IL: Illinois Department of Transportation.
- Bureau of Bridges and Structures. (2017). Structural Services Manual - 2017. Springfield, IL: Illinois Department of Transportation.
- California Department of Transportation. (2010). Standard Specifications. Sacramento: California Department of Transportation.
- Caltrans. (2020, January 24). Search Parameters. Retrieved from Contract Cost Data: <https://sv08data.dot.ca.gov/contractcost/index.php>
- Egli, B. (2012, April 23-25). Preserving Tennessee's Bridge Decks and Joints. SEBPP Meeting. Atlanta, GA.
- ElBatanouny, M. K., Nadelman, E., Kurth, J. C., & Krauss, P. D. (2017). TR717, Use of Polymer Overlays or Sealers on New Bridges. Ames, IA: Iowa Department of Transportation.
- Hunsucker, D. Q., Ashurst, K. H., Rister, B. W., Allen, D. L., & Grady, E. (2018). Longer Lasting Bridge Deck Overlays. Lexington, KY: Kentucky Transportation Center.
- Illinois Department of Transportation. (2016). Standard Specifications for Road and Bridge Construction. State of Illinois.
- Indiana Department of Transportation. (2013). Chapter 412 Bridge Preservation. In 2013 Design Manual. Indianapolis, IN: Indiana Department of Transportation.
- Indiana Department of Transportation. (2013). Chapter 72 Bridge Rehabilitation. In 2013 Design Manual. Indianapolis, IN: Indiana Department of Transportation.

-
- Indiana Department of Transportation. (2014, May 1). 738-B-297 Polymeric Concrete Bridge Deck Overlay. Indiana Department of Transportation.
- Indiana Department of Transportation. (2018). INDOT - Pay Items List/Unit Price Summaries. Retrieved from Indiana Department of Transportation: <https://www.in.gov/dot/div/contracts/pay/>
- Iowa Department of Transportation. (2015, October 20). Developmental Specifications for Bridge Deck Over-Depth Repair and Overlay. Ames, IA: Iowa Department of Transportation.
- Iowa Department of Transportation. (2017, April). Prepare Cost Estimate using BIAS.
- Iowa Department of Transportation. (2019, April 16). Developmental Specifications for High Performance Thin Lift Overlay. Ames, IA: Iowa Department of Transportation.
- Iowa Department of Transportation. (2019). Section 2413. Bridge Deck Surfacing, Repair, and Overlay. Ames, IA.
- Kansas Department of Transportation. (2013, November 25). Section 729 Multi-Layer Polymer Concrete Overlay. Special Provision to the Standard Specifications, 2007 Edition. Kansas City, KS: Kansas Department of Transportation.
- Kansas Department of Transportation. (2014, May 16). Section 717 Bridge Overlays. Special Provision to the Standard Specifications, Edition 2007. Kansas City, KS: Kansas Department of Transportation.
- Krauss, P. D., Lawler, J. S., & Steiner, K. A. (2009). Guidelines for Selection of Bridge Deck Overlays, Sealers and Treatments, Project 20-07. Northbrook: National Cooperative Highway Research Program, Transportation Research Board.
- Lane, S. (2013). FHWA-HRT-16-079, FHWA LTBP Summary - Current Information on the Use of Overlays and Sealers Summary Report. McLean, VA: Federal Highway Administration Long-Term Bridge Performance Program.
- Li, L., Xi, Y., & Railsback, R. (2018). Evaluation of Different Types of Waterproofing Membranes (Asphaltic and Non-Asphaltic) as Cost Effective Bridge Deck Barriers in Reducing Corrosive Chloride Effects. Denver, CO: Colorado Department of Transportation.
- Martens, P. (2015). Latex Modified Concrete for Bridge Deck Overlays. Columbus, OH: Ohio Transportation Engineering Conference.
- McGhee, K. H. (1982). Control of Reflection Cracking in a Fabric-Reinforced Overlay on Jointed Portland Cement Concrete Pavement. Charlottesville, VA: Virginia Highway and Transportation Research Council.
- Michigan Department of Transportation. (2012). English Bridge Design Manual. Retrieved from Michigan Department of Transportation: <https://mdotjboss.state.mi.us/stdplan/englishbridgemanual.htm>
- Michigan Department of Transportation. (2012). Standard Specifications for Construction. Retrieved from Michigan Department of Transportation: <https://mdotjboss.state.mi.us/SpecProv/specBookHome.htm>
- Michigan Department of Transportation. (2019). LAP - Bridge Cost Estimate Worksheet. Michigan Department of Transportation.

-
- Minnesota Department of Transportation. (2017). 2017_MN_Bridge Scoping Cost Estimate Template-2045581-v1. Minnesota Department of Transportation.
- Minnesota Department of Transportation. (2018). Standard Specifications for Construction. St. Paul, MN: Minnesota Department of Transportation.
- Missouri Department of Transportation. (2018). 2018 Unit Bid Prices. Missouri Department of Transportation.
- Missouri Department of Transportation. (2018). Section 505 Bridge Deck Concrete Wearing Surface. In Missouri Standard Specifications for Highway Construction. Jefferson City, MO: Missouri Highways and Transportation Commission.
- Nebraska Department of Transportation. (2017). Standard Specifications for Highway Construction. Lincoln, NE: Nebraska Department of Transportation.
- Nebraska Department of Transportation. (2019). English Average Unit Price for Lettings, July 1, 2018 to June 30, 2019. Nebraska Department of Transportation.
- New York State Department of Transportation Engineering Division. (2018). Standard Specifications (US Customary Units) Construction and Materials. Albany, NY: New York State Department of Transportation.
- North Dakota Department of Transportation. (2014). Standard Specifications for Road and Bridge Construction. Bismarck, ND: North Dakota Department of Transportation.
- North Dakota Department of Transportation. (2018). Price Sheet List for 2018, Totals Last Calculated 12/10/2018. North Dakota Department of Transportation.
- Office of Project Development - Bid Letting. (2018). Average Unit Prices from Low Bids, January 01, 2017 to December 31, 2017. South Dakota Department of Transportation.
- Ohio Department of Transportation. (2017, January 20). Supplemental Specification 847 Bridge Deck Repair and Overlay with Concrete Using Scarification and Chipping. Ohio Department of Transportation.
- Ohio Department of Transportation. (2017, January 20). Supplemental Specification 848 Bridge Deck Repair and Overlay with Concrete Using Hydro-Demolition. Ohio Department of Transportation.
- Ohio Department of Transportation. (2018). 2018Itemdata. Ohio Department of Transportation.
- Ohio Department of Transportation. (2018, April 20). Supplemental Specification 858 Thin Polymer (Epoxy) Overlays for Structural Slabs. Ohio Department of Transportation.
- Ohio Department of Transportation. (2019). Construction and Material Specifications. Columbus, OH: Ohio Department of Transportation.
- Park, P. (2012). Characteristics and Applications of High-Performance Fiber Reinforced Asphalt Concrete. Dissertation for PhD in Civil Engineering at the University of Michigan. Ann Arbor, Michigan: University of Michigan.
- Ramey, G. E., & Oliver, R. S. (1998). Rapid Rehabilitation/Replacement of Bridge Decks. Alabama Department of Transportation.
- Russell, H. G. (2012). Synthesis 425: Waterproofing Membranes for Concrete Bridge Decks. Washington D.C.: NCHRP.

Sanders, P. J. (2001, October). Reinforced asphalt overlays for pavements. Dissertation for PhD in Civil Engineering, University of Nottingham. Nottingham, United Kingdom: University of Nottingham.

Smyl, D., Mohammadian, A., Park, S., Lucier, G., & Pour-Ghaz, M. (2017). The Use of Fiber Reinforcement in Latex Modified Concrete Overlay. Raleigh, NC: North Carolina Department of Transportation.

South Dakota Department of Transportation. (2015). Standard Specifications for Roads and Bridges. Pierre, SD: South Dakota Department of Transportation.

Sprinkel, M. M., & Apeageyi, A. K. (2013). Evaluation of the Installation and Initial Condition of Rospphalt Overlays on Bridge Decks. Charlottesville, VA: Virginia Center for Transportation Innovation and Research.

Tabulation of Construction and Material Bids. (2019, October 18). IowaDOT Contracts and Specifications Bureau.

Virginia Department of Transportation. (2016). 2016 Road and Bridge Specifications. Richmond, VA: Virginia Department of Transportation.

Virginia Department of Transportation. (2019). Statewide Averages Jul 1, 2017 Through Aug 1, 2019. Virginia Department of Transportation.

Wibowo, H., & Sritharan, S. (2018). Use of Ultra-High Performance Concrete for Bridge Deck Overlays. Ames, IA: Iowa Deaprtment of Transportation.

Wisconsin Department of Transportation. (2019). Average Unit Price List. Wisconsin Department of Transportation.

Wisconsin Department of Transportation. (2019). Chapter 40 - Bridge Rehabilitation. In WisDOT Bridge Manual. WisDOT.

Wisconsin Department of Transportation. (2020). Standard Specifications for Highway and STructure Construction. Madison, WI: Wisconsin Department of Transportation.

APPENDIX A. EXPANDED LITERATURE REVIEW

The information in this appendix expands on the introductions to the overlay types that were presented in Chapter 2, and provides additional background information for Chapter 3 by incorporating deeper discussion of the qualitative considerations when selecting an overlay system. This appendix is organized into three sections. Section A.1 discusses the advantages and disadvantages of each type of overlay identified in Chapter 2. Section A.2 is an overview describing which states use which overlays, how overlay use has changed with time according to nation-wide studies, and general deck conditions when the overlays are applied. Finally, Section A.3 describes the standard bridge deck overlay practices of the eleven states reviewed in this report (California, Illinois, Indiana, Kansas, Michigan, Minnesota, Missouri, Nebraska, New York, North Dakota, Ohio, South Dakota, Virginia, and Wisconsin) in depth for each overlay type.

A.1 Comparison between Overlay Types

Agencies desire overlays that provide good service and are easy to construct and low cost. The overlays introduced in this report have trade-offs in each of these areas. Their advantages and disadvantages are presented in Table A-1 and discussed further below.

A.1.1 Performance/Service Discussion

Good performance/service is broken down into proven performance, ride quality, construction duration, permeability, added dead load, inspection access to deck, and removal difficulty. Projects that have demonstrated success previously are considered low risk and as a result proven performance is highly desirable. LMC and LSDC overlays have been used since 1957 and the early 1960s, respectively, and have generally proven that they can last between about 15 and 30 years (Ramey & Oliver, 1998; Krauss, Lawler, & Steiner, 2009). States began to use SFC overlays in the 1980s and SFC overlay application increased in the 1990s. HPC overlays have shown to have comparable service lives to LMC overlays (Krauss, Lawler, & Steiner, 2009). States also began using TPOs in the 1980s and have reported service lives ranging from about 5 to 20 years (Wisconsin Department of Transportation, 2019; Krauss, Lawler, & Steiner, 2009; Ramey & Oliver, 1998). Most references suggest that for HMA overlays, less than 15 years and as low as 3 years should be expected (Krauss, Lawler, & Steiner, 2009; Wisconsin Department of Transportation, 2019; Minnesota Department of Transportation, 2018). HMA with WPM systems have typically demonstrated service lives between 10 and 20 years (Balakumaran, Weyers, & Brown, 2017; Krauss, Lawler, & Steiner, 2009; Li, Xi, & Railsback, 2018). In comparison, little has been reported on LMCVE overlays. States began to use LMCVE overlays in the 1990s, with the first project in 1991 (Martens, 2015). Virginia, a leading state in LMCVE overlays, began applying them in 1997 (Balakumaran, Weyers, & Brown, 2017) and Ohio, Missouri, and North Carolina have investigated LMCVE overlays as well (Smyl, Mohammadian, Park, Lucier, & Pour-Ghaz, 2017). Results have been mixed, but when the deck does not experience early-age cracking, the service life is comparable to that of regular LMC overlays or even better (Martens, 2015). Of the miscellaneous asphalt overlays, Rosphalt overlays, which were developed in 1983, have been the most common although polymer-modified asphalt (PMA) overlays have also been used. Relatively few references are available on the long-term performance of these overlays, and while lives between 10 and 15 years are considered reasonable (Krauss, Lawler, & Steiner, 2009; Wisconsin Department of Transportation, 2019), the lack of publication indicates that their performance is not as well-established as that of alternative overlays. Little has been reported regarding PPCO because they are rarely used outside the western states. California has reported

using PPCO since before 1998 (Ramey & Oliver, 1998) and a unique case study was conducted by Washington State in which a 1-inch thick polymer inlay was used on an asphalt surface (Anderson, et al., 2019). UHPC overlays also do not have proven performance, although this is because UHPC is a relatively new material that was not used in the field until about 2010. UHPC overlays are considered experimental.

Overlays that can improve ride quality and skid resistance are also desirable. The majority of overlays are capable of improving ride quality. Because unsound concrete and spalls must be repaired prior to placement, potholes are removed and the thickness of the overlay permits the surface to be re-graded. TPO overlays are the only overlays that generally do not improve ride quality. Due to their thin nature, they follow the original grade of the deck surface and cannot modify it.

Skid resistance is typically compromised due to severe exposure to heavy traffic and/or snow tires. If the original concrete wearing surface becomes worn under these conditions, cementitious and bituminous overlays will follow the same trend. UHPC overlays have the potential to provide greater abrasion resistance and long-term skid resistance, but as discussed previously, this performance is not proven. Polymer overlays or polymeric chip seals (a one-layer polymer overlay) are commonly used to improve skid resistance, but abrasion-controlled service lives under 10 years have been reported for these overlays (Balakumaran, Weyers, & Brown, 2017). In general, overlays to improve skid resistance must be reapplied relatively frequently.

Short construction durations are desired to minimize traffic interruption. In general, the cementitious overlays have relatively long construction times because of the extensive surface preparation required and the relatively long curing times. While milling or hydrodemolition may take short time, removing unsound concrete by hand, particularly past the rebar, can take longer periods, and any patches are usually cured prior to overlay installation. This preparation is not followed for HMA overlays sometimes, especially if they are intended to be temporary, and while it is considered good practice for HMA with WPM systems, some states do not specify repair of the concrete wearing surface prior to placing the waterproofing membrane either (Krauss, Lawler, & Steiner, 2009). Concrete repairs are completed for polymeric overlays when the overlay is being applied to a deteriorated surface, but because TPOs are typically applied early in the life of the deck, hand-removal and patching is generally not expected. With regards to curing times, cementitious overlays generally require about 3 days to obtain the required strength (Balakumaran, Weyers, & Brown, 2017; Hunsucker, Ashurst, Rister, Allen, & Grady, 2018). Due to the use of rapid-setting cements, LMCVE overlays can be opened in about half a day (Balakumaran, Weyers, & Brown, 2017), making them the quickest cementitious overlay to install. This is on par with the curing duration of polymer overlays (ElBatanouny, Nadelman, Kurth, & Krauss, 2017). Bituminous overlays do not require a curing period.

Table A-1. Qualitative comparison between overlay types. A checkmark represents a relatively advantageous feature. An x represents a relatively disadvantageous feature.

Characteristic	PCC	LSDC	HPC	UHPC ^e	LMC	LMCVE	HMA	Misc. Asphalt	HMAWMM	TPO	PPCO
Performance/Service:											
Proven performance	✓	✓	✓	✗	✓	✗	✓	✓	✓	✓	✓
Ride quality	✓	✓	✓	✓	✓	✓	✓	✓	✓	✓	✓
Construction duration	✗	✗	✗	✗	✗	✓	✓	✓	✓	✓	✓
Permeability	✗	✓	✓	✓	✓	✓	✗	✓	✓	✓	✓
Added dead load	✗	✗	✗	✗	✗	✗	✗	✗	✗	✓	✗
Inspection access to deck	✓	✓	✓	✓	✓	✓	✗	✗	✗	✗	✗
Removal difficulty	✓	✓	✓	✗	✓	✓	✓	✓	✗	✓	✓
Ease of Construction:											
Standard equipment	✓	✓	✓	✓	✗	✗	✓	✓	✓	✗	✗
Sensitivity to ambient conditions:											
Moisture	✓	✓	✓	✓	✓	✓	✓	✓	✓	✗	✗
Temperature	✓	✓	✓	✓	✓	✓	✓	✓	✓	✗	✗

Just as chloride-induced corrosion is a widespread failure mechanism for bridge decks, chloride-induced corrosion is also a common failure mechanism for all of the overlays presented, regardless of type. Any chloride-contaminated concrete that remains can cause continuing corrosion of the steel, which will result in the same deterioration process as was seen in the original deck. However, new chlorides may also diffuse through the new overlay to the rebar and therefore overlays with low permeability are desired. PCC overlays generally do not provide any improved chloride penetration resistance than the original concrete. However, LSDC, HPC (particularly SFC), and UHPC overlays, provide improved resistance due to their lower permeability. LMC overlays have demonstrated comparable chloride penetration resistance to SFC overlays, and LMCVE overlays have even shown slightly better resistance (Sprinkel & Apeageyi, 2013). Compared to concrete, asphalt is a relatively permeable material and generally does not offer good chloride penetration resistance (Balakumaran, Weyers, & Brown, 2017). However, Rosphalt and other specialized asphalts with high binder contents can effectively function as a waterproofing membrane and, therefore, a chloride barrier due to decreased porosity. Similarly, HMA with WPM systems also provide good chloride protection as long as the waterproofing membrane is intact. The polymeric binders of thin and pre-mixed polymer overlays are relatively impermeable to chloride ions. However, it is important to note that thickness affects the chloride resistance considerably. Chip seals (essentially a one-layer TPO) offer very little chloride resistance because the aggregates are ripped out of the binder during service, leaving behind cracks and holes through which chlorides can penetrate. Additional layers prolong the integrity of the overlay, but TPOs are susceptible to this wear.

Increased dead load due to the overlay is another primary consideration when selecting the overlay type. Cementitious overlays and bituminous overlays generally have comparable unit weights of about 150 pcf. UHPC overlays have a slightly higher unit weight at about 155 pcf; however, UHPC overlays are relatively thin and, therefore, the additional dead load may be less than that of a more common cementitious overlay. In comparison, asphalt overlays may be several inches thicker than cementitious overlays in order to protect the underlying waterproofing membrane or provide the desired ride quality. Polymeric concrete used in TPOs and PPCOs has a slightly lower unit weight of about 135 pcf and as a result, TPOs are the most favorable if increased dead load is the primary concern.

Another desirable quality is inspection access to the deck. Monitoring the continued degradation of the deck is an important part of deck management, particularly late in the life of the deck. To a certain extent, all overlays will prevent visual inspection or non-destructive inspection techniques such as sounding and half-cell potential from being feasible because the original surface is covered. Overlays that prevent moisture intrusion and overlays that are relatively thick limit access more than standard cementitious overlays, which can be treated as though they were the original concrete cover. Inspection concerns are most associated with asphalt overlays with or without waterproofing membrane (Balakumaran, Weyers, & Brown, 2017; Wisconsin Department of Transportation, 2019).

The final consideration is the ease with which the overlay can be removed. If subsequent overlays are desired, the original overlay must be milled off. This can be done relatively easily for all overlays except UHPC overlays and HMAWM systems. The very high strength of the UHPC and the presence of the waterproofing membrane in the HMAWM system make them difficult to remove. However, this should not be a concern if the bridge is scheduled for replacement after the late-life overlay.

A.1.2 Ease of Construction Discussion

Ease of construction is divided into workability, set time, specialized equipment, and sensitivity to ambient conditions, including moisture, temperature, and vibrations from traffic if the bridge remains in-service during construction. Good workability and suitable setting time are important to ensure a high-quality product. If the overlay is difficult to compact, then there is an increased chance of voids, especially around any exposed rebar. This is primarily a risk of LSDC overlays and SFC overlays, although it is typically overcome by using high-range water reducers. Quick setting times can cause difficulties finishing the surface and beginning the curing process in time to prevent cracking. Overlays with low water-to-cement ratios, high amounts of silica fume, and/or fast-setting cements are the most challenging in this regard.

The need for specialized equipment beyond the equipment required to mix, lay, and/or finish a typical concrete or asphalt mix is generally associated with higher costs and specialized expertise. PCC, LSDC, HPC, and UHPC overlays generally do not need specialized equipment, although most of these overlays are mixed on site and specialized finishing equipment may be desired to better facilitate the curing process and reduce the risk of poor-quality construction (Wisconsin Department of Transportation, 2019). The bituminous overlays do not require specialized equipment beyond what is already in place for asphalt pavements. Waterproofing membranes are typically applied by hand, either using spray equipment or rollers and squeegees (Russell, 2012). LMC and LMCVE require special mixing equipment on-site due to the polymeric addition and fast set (Balakumaran, Weyers, & Brown, 2017). Similarly, the polymeric overlays both require specialized equipment.

The sensitivity of the overlay to ambient conditions during construction also presents a risk to the construction quality. Unfavorable conditions can compromise service life by causing cracking in cementitious overlays and poor bond or curing complications in polymeric overlays. LMC, LMCVE, and polymeric overlays are particularly susceptible to humidity and temperature and values outside of the bounds recommended by the manufacturers can compromise curing (Balakumaran, Weyers, & Brown, 2017; Krauss, Lawler, & Steiner, 2009). Cementitious overlays are also susceptible to humidity and temperature due to higher risks of cracking when conditions favor high levels of evaporation. Weather has not been identified as a concern for asphalt overlays, although higher temperatures and lower humidities are desirable. While not a weather-related phenomenon, vibrations from traffic if the bridge is in use during construction have also been identified as a potential issue for LSDC and LMC overlays (Krauss, Lawler, & Steiner, 2009).

A.2 Nation-Wide Practice

Nation-wide surveys of overlay practice were conducted in 1998 by Ramey and Oliver and later in 2009 by Krauss, Lawler, and Steiner. Ramey and Oliver (1998) requested information specifically related to rapid overlay construction and badly deteriorated overlays. Krauss et al. (2009) requested detailed information regarding general overlay practice. The types of overlays (cementitious, bituminous, or polymeric) used by the respondents in the 1998 study are presented in Figure A-1 and the types used by the respondents as reported in the 2009 study are presented in Figure A-2. Specific breakdowns of the types of cementitious and bituminous overlays used as reported to Krauss et al. in 2009 are presented in Figure A-3 and Figure A-4, respectively.

While Krauss et al. (2009) did not specifically request late-life information, respondents were asked to identify when the different types of overlays were typically applied in terms of the extent of deterioration. The results are summarized in Table A-2. More than 60% of the respondents use LMC, HPC, HMA with WPM, PCC, and/or LSDC overlays when the deck is in poor condition and more than 10% of the deck surface has spalled or been patched. Polymeric overlays, representing both TPOs and PPCOs, and miscellaneous asphalt overlays, representing standard HMA overlays as well as Rosphalt or polymeric asphalt overlays, are used more often for decks in good condition.

Table A-2. Description of the percentage of respondents in Krauss et al. (2009) to use each type of overlay for the following bridge deck conditions.

Time of Application	Polymeric	LMC	HPC	HMA with WPM	PCC	LSDC	Misc. Asphalt
Deck with cracking in good condition with no significant active corrosion	79%	35%	20%	64%	17%	33%	67%
Deck with cracking and active corrosion (< 5% delamination, no spalling)	47%	47%	47%	50%	33%	33%	67%
Deck with cracking and active corrosion (> 5% delamination and some spalling)	32%	59%	60%	57%	33%	50%	33%
Deck with cracking and active corrosion (> 10% spalling/patching)	32%	76%	80%	71%	67%	100%	33%
No. of respondents	19	17	15	14	6	6	3

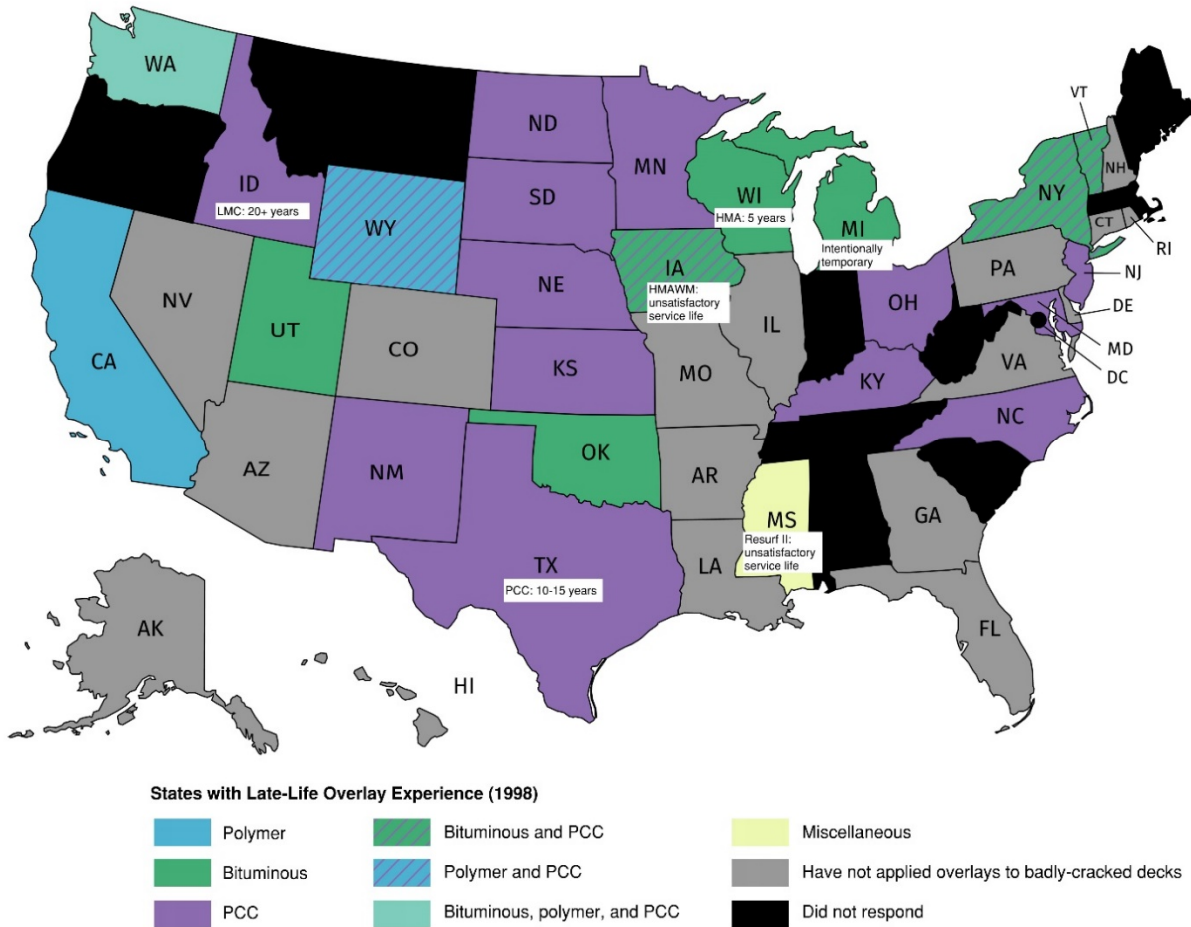

Figure A-1. States with experience placing overlays on badly-deteriorated decks and the types of overlays used, as reported to Ramey and Oliver (1998). Comments provided by states regarding service life of these overlays is included (created with mapchart.net).

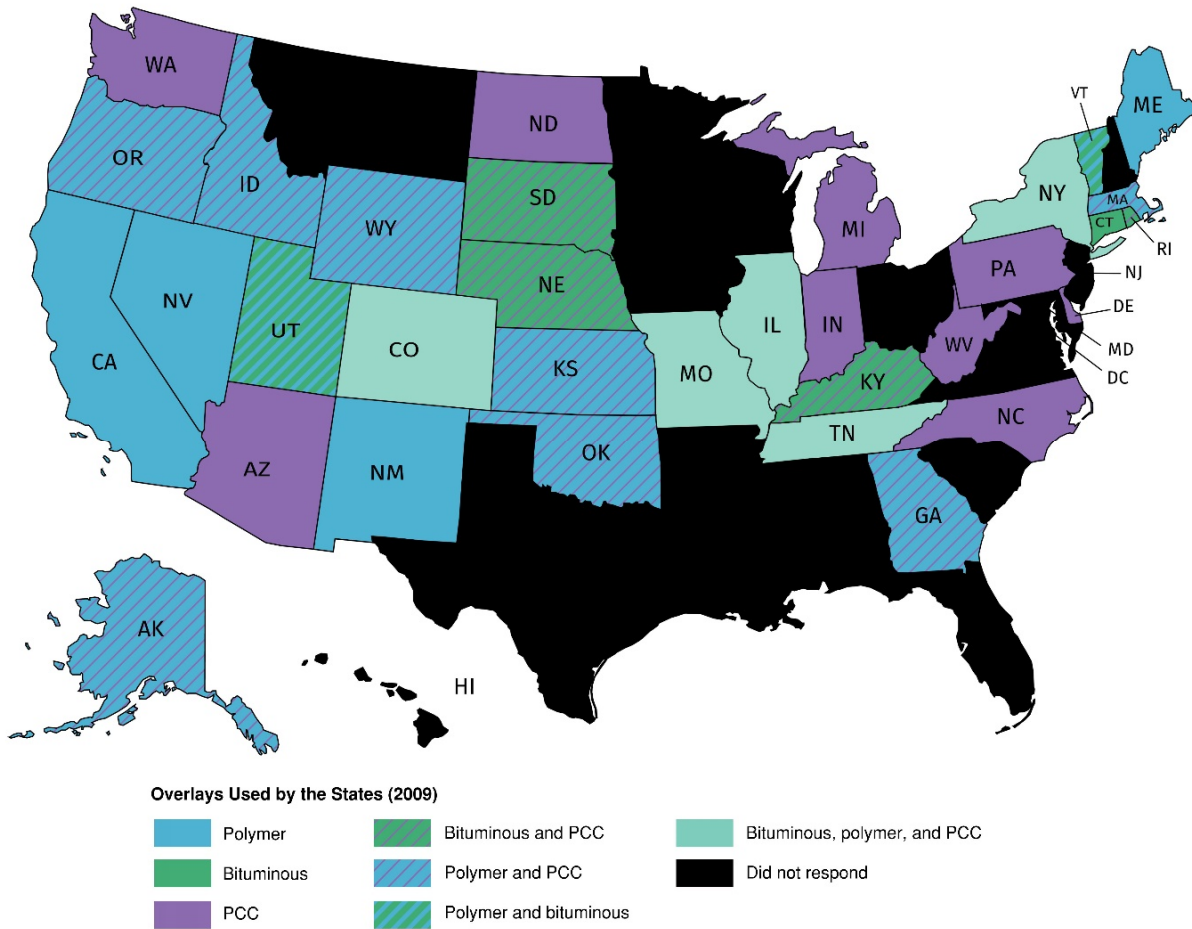

Figure A-2. States with experience placing overlays and the types of overlays used, as reported to Krauss et al. (2009) (created with mapchart.net).

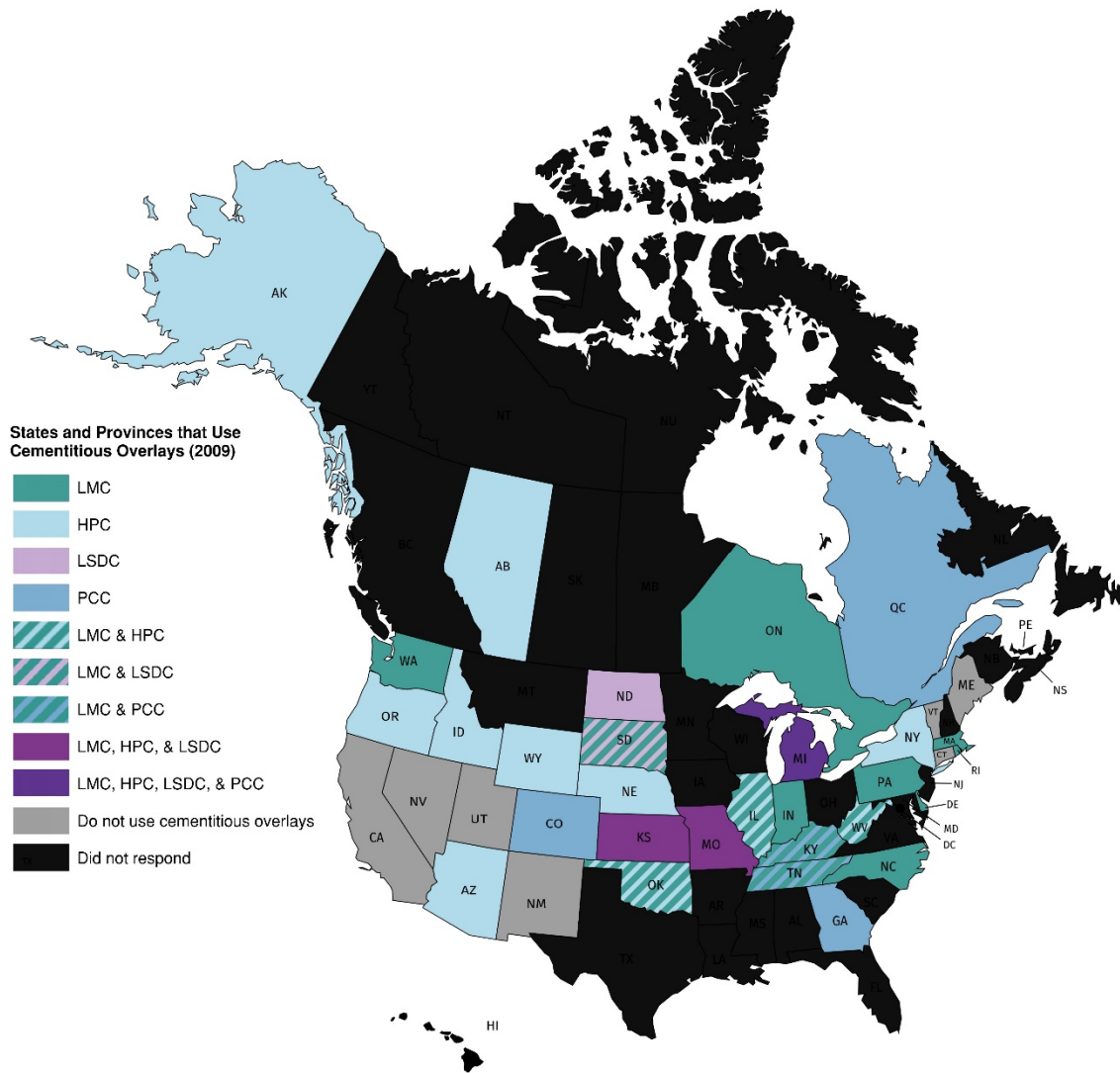

Figure A-3. The types of cementitious overlays used in the United States and Canada, as reported to Krauss et al. (2009) (created with mapchart.net).

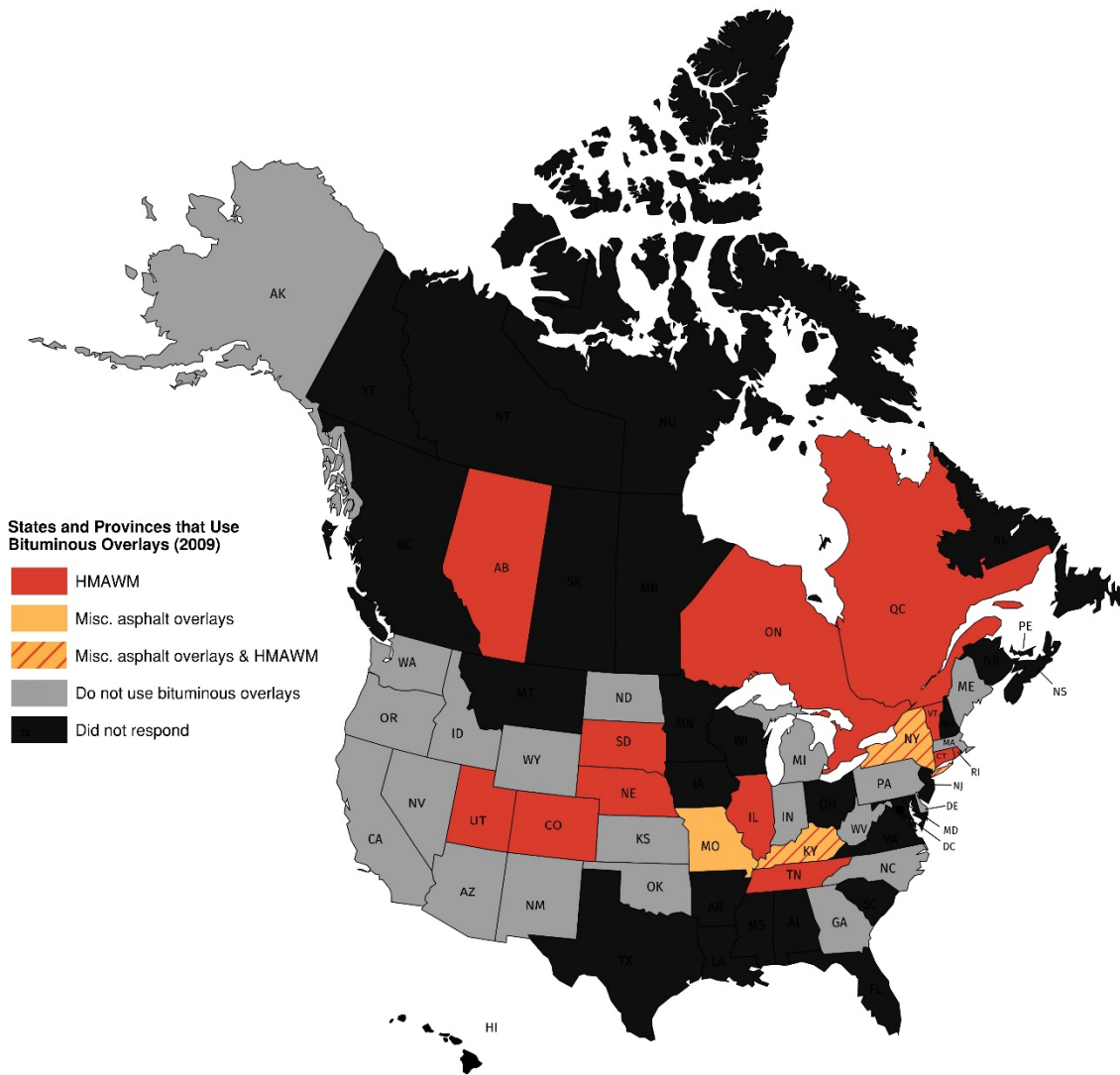

Figure A-4. The types of bituminous overlays used in the United States and Canada, as reported to Krauss et al. (2009 (created with mapchart.net).

A.3 Details of State Practices

The types of overlays and standard procedures of states bordering Iowa were investigated in detail due to the assumption that these states will have the most comparable exposure conditions and deicing practices to Iowa. These states were Illinois, Indiana, Kansas, Michigan, Minnesota, Nebraska, North Dakota, Ohio, South Dakota, and Wisconsin. Practices of New York, California, and Virginia were also included in the review.

A.3.1 PCC and LSDC overlays

Conventional PCC overlays are currently specified by 6 states besides Iowa: Illinois, Kansas, Minnesota, Nebraska, New York, and North Dakota. This type of overlay has similar characteristics to the Class HPC-O concrete overlay in Iowa and, therefore, mixture designs and procedures will not be discussed in detail. The Minnesota DOT specifies that concrete overlays with a thickness of up to 3 inches may be placed over

deteriorated concrete as a short-term solution. In these scenarios, up to 10 to 15 years of service are expected. Preparation consists of removing bituminous patches and scarifying 1/2-inch from the deck thickness, but does not require removal of deteriorated concrete.

Low-slump concrete overlays are currently specified by 5 states: Minnesota, Missouri, North Dakota, South Dakota, and Wisconsin. Low-slump concrete overlays were seldomly used in Indiana, and are no longer specified because they have similar characteristics to latex-modified concrete overlays and are more expensive. This type of overlay has similar characteristics to Class O concrete overlays in Iowa and, therefore, its mixture designs will not be discussed.

A.3.2 MSC/SFC overlays

Microsilica concrete overlays are currently specified by 8 states: Illinois, Indiana, Michigan, Missouri, Nebraska, New York, Ohio, and Virginia. Indiana states that a MSC/SFC overlay may be used if an overlay with low diffusivity is desirable. Virginia still uses SFC overlays, but generally prefers LMC overlays due to their comparable performance. SFC overlays had been used in Wisconsin in the past, but are not used currently.

The Missouri and New York DOTs provide prescriptive requirements for SFC overlay mixture designs and Ohio provides mixture design guidance as well, as shown in Table A-3. New York additionally has a Class DP concrete with lower cementitious material content. As can be seen, SFC overlay mixtures typically have between 6% and 10% silica fume replacement of cement.

Table A-3. SFC overlay mixture designs, according to NYSDOT, Missouri DOT, and Ohio DOT.

Properties	Requirements (New York)	Requirements (Missouri)	Typical Mixture (Ohio)
Air Content	5 - 8%	5%	6 - 10%
Slump	2 - 6 inches	3 - 7.5 inches	4 - 8 inches
Fine aggregate content	53%vol of total agg.	50 - 55%vol of total agg.	1355 lb/cu. yd
Coarse aggregate content	Not provided	Not provided	1370 lb/cu. yd
Total cementitious material content (Type I Portland cement shall be used)	657 lb/cu. yd	640 lb/cu. yd min.	700 lb/cu. yd
Silica fume	61 lb/cu. yd	6 - 8%wt of cm	50 lb/cu. yd
Net w/cm ratio	0.37	0.37 max.	0.36 max.
High range water reducer	Not provided	As required	Not provided

Illinois specifies a thickness between 2.25 inches and 3.5 inches for non-structural SFC overlays with no reinforcing bars or wire mesh. Nebraska requires a minimum thickness of 2 inches, and New York a minimum thickness of 1.5 inches. Michigan requires shallow SFC overlays to be at least 1.5 inches thick and deep SFC overlays to have a thickness of at least 3 inches. Shallow SFC overlays are expected to last approximately 10 to 15 years while deep SFC overlays are expected to last approximately 20 to 30 years.

Surface preparation procedures include scarification, hydrodemolition, and blast cleaning. Illinois requires at least 1/4 inch of the deck be scarified to fully remove any waterproofing membrane and provide a roughened surface. Michigan also requires scarification and hydrodemolition while Nebraska requires the deck be sandblasted and cleaned, and New York simply specifies blast cleaning.

To promote good curing and bond, Missouri and New York require the deck be wetted prior to overlay placement. Missouri specifies the deck be thoroughly and continuously wet for at least 3 hours and covered with PE sheeting until placement. New York specifies the concrete reach a SSD condition. Missouri specifies that ambient temperatures be between 45 and 85°F during placement, New York states they should not exceed 85°F, and Nebraska states they should not exceed 77°F. Ohio requires the shortest minimum wet cure time of 3 days. New York requires a minimum wet cure of 4 days, unless Class DP concrete is used in which case the minimum wet cure time is 7 days. Missouri and Nebraska also require minimum wet curing periods of 7 days prior to opening to traffic. If the concrete does not achieve a compressive strength of 3,000 psi within this time, then Missouri requires the wet curing period to continue until this strength is reached.

A.3.3 LMC and LMCVE overlays

LMC overlays are currently specified by 8 states: Illinois, Indiana, Michigan, Minnesota, Missouri, Ohio, South Dakota, and Virginia. LMCVE overlays are only specified by 2 states: Missouri and Virginia. Indiana has used LMC overlays since the early 1970s and they continue to be the most common bridge-overlay technique used in the state. Latex-modified concrete overlays had been used in Wisconsin in the past, but are not currently specified.

For a bridge deck to qualify for a LMC overlay in Indiana, the deck, superstructure, and substructure must each have a bridge inspection rating of at least 5 according to the National Bridge Inspection Standards and the partial depth patching must be less than 15%. Indiana expects an average life of 15 years from LMC overlays and in Michigan, LMC overlays are expected to last approximately 10 to 15 years.

Missouri and Ohio provide mixture design guidance for LMC overlays, as shown in Table A-4, and Missouri and Virginia provide mixture design guidance for LMCVE overlays, as shown in Table A-5. Missouri does not permit air entraining admixtures to be used for either LMC or LMCVE overlays. For LMCVE overlays, Missouri specifies that a Type HE high-early-strength cement in accordance with ASTM C1157 may be used and Type III portland cements are prohibited. Virginia uses rapid-hardening cements with a typical composition of one part calcium sulfoaluminate and two parts dicalcium silicate for very high early strength LMC overlays.

Table A-4. LMC overlay mixture designs, according to Missouri DOT and Ohio DOT.

Properties	Requirements (Missouri)	Typical Mixture (Ohio)
Air Content	6.5% max.	7% max.
Slump	9 inches max.	4 - 6 inches
Fine aggregate content	50 - 55%vol of total agg.	1315 lb/cu. yd
Coarse aggregate content	Not provided	1645 lb/cu. yd
Total cementitious material content	658 lb/cu. yd min. (Type I/II)	658 lb/cu. yd
Latex emulsion admixture (LEA)	24.5 gal/cu. yd min.	24.5 gal/cu. yd
Net w/cm ratio	0.40 max.	Not specified
Net water	Not specified	17.5 gal max.

Table A-5. LMCVE overlay mixture designs, according to Missouri DOT and Virginia DOT.

Properties	Requirements (Missouri)	Typical Mixture (Virginia)
Air Content	6.5% max.	Not specified
Slump	3 to 6 inches	Not specified
Fine aggregate content	50 - 55%vol of total agg.	Not specified
Coarse aggregate content	Not provided	Not specified
Total cementitious material content	658 lb/cu. yd min.	658 lb/cu. yd min.
Latex emulsion admixture (LEA)	24.5 gal/cu. yd min.	15%wt of cement
Net w/cm ratio	0.40 max.	0.40 max.

The Illinois standards for LMC overlays are very similar to the standards for SFC overlays, and as such thicknesses between 2.25 and 3.5 inches are common. Michigan specifies a minimum thickness of 1.5 inches for LMC overlays and Missouri specifies a maximum thickness of 3 inches for LMCVE overlays.

Surface preparation consists of removing concrete and roughening the deck surface. In Indiana, any existing LMC overlay must be removed and milling performed to remove 0.5 inches of the deck. Unsound concrete is then removed by hydrodemolition. In Michigan, the existing deck is also scarified by 0.25 inches and then another 0.75 inches is hydrodemolished. Missouri requires that decks be sandblasted and then air blasted.

Curing practices are similar to those for SFC overlays. Missouri requires the deck be thoroughly wetted for at least 3 hours for LMC overlays and at least 1 hour for LMCVE overlays, then covered with PE sheeting until overlay placement. Ohio only requires a minimum pre-wetting period of 1 hour for LMC overlays. Ambient temperatures are required to be between 45 and 85°F by Missouri and 40 and 85°F by Ohio.

Ohio requires that LMC overlays be wet cured for 48 hours, followed by 2 days of dry air curing before opening to traffic. Missouri requires a minimum wet cure period of 48 hours and a minimum total curing time of 3 days before and LMC overlay may be opened to traffic. The compressive strength must also reach 3,000 psi prior to reopening. For LMCVE overlays, Missouri requires wet curing until the concrete has attained a compressive strength of at least 3,200 psi, at which point it may be opened to traffic. Virginia requires that LMCVE overlays achieve a compressive strength of at least 2,500 psi within 3 hours and 3,500 psi at 24 hours. As in Missouri, LMCVE overlays are wet-cured until they achieve a strength of 3,500 psi, at which point they may be opened to traffic.

A.3.4 Polymer concrete overlays

Polymer concrete overlays are currently specified by 10 states: California, Illinois, Indiana, Kansas, Michigan, Minnesota, Missouri, Nebraska, Ohio, Virginia, and Wisconsin. There are generally two types of polymeric overlays: thin polymer overlays (TPOs) and premixed polymer concrete overlays (PPCOs). The majority of these states use epoxy as the binding polymer for TPOs while California uses PPCOs, using polyester polymer concrete, exclusively. Indiana, Kansas, Minnesota, and Wisconsin permit either epoxy or polyester to be used. Minnesota began using epoxy in 2007 but uses it more commonly than polyester, and Nebraska uses polyester, epoxy, or epoxy-urethane as the binder. Indiana is the only state to specify that a special type of aggregate be used.

In order for a bridge deck to be a candidate for a polymer overlay, Indiana requires that the wearing surface, deck, superstructure, and substructure have a bridge inspection rating of 5 or higher based on the National

Bridge Inspection Standards. Wisconsin recommends TPOs be reserved for decks with a bridge inspection rating of 8 or 9 and no more than 2% distress on their wearing surface. PPCOs, which are generally a little thicker than epoxy TPOs, may be used on decks that are less than 15 years old and have a bridge inspection rating of 7 or greater and no more than 5% distress on their wearing surface. Indiana states that an average service life of 10 years may be expected. Minnesota considers PPCOs to have a longer service life compared to their thinner epoxy counterparts.

A two-layer application method is the most common construction procedure for thin polymer overlays. The polymer is first applied to the surface, then the aggregates are broadcast on top, forming the first layer, and then the process is repeated to make the second layer. Kansas requires that the second layer use higher application rates for both the polymer and the aggregates, resulting in a thicker layer. Nebraska specifies a prime coat. Missouri also specifies a prime coat if recommended by the manufacturer and requires each layer have the same thickness. Minnesota specifies epoxy TPOs be placed in two layers, while premixed polyester polymer overlays are placed in a single, thicker lift with the aggregate pre-mixed. Premixed or slurry mixtures as specified by Minnesota are more commonly used for polyester overlays.

Both Wisconsin and Missouri require that the total thickness of an epoxy TPO be at least 0.25 inches. Minnesota states that a two-layer epoxy TPO typically has a thickness of about 0.375 inches. Nebraska specifies a minimum overlay thickness of 0.75 inches for polyester polymer concrete overlays, and Wisconsin states that PPCOs are typically between 0.75 inches and 1 inch.

Regarding preparation of the deck surface, California specifies that the deck must be dry prior to placing the prime coat. The deck temperature should be between 50 and 100°F and the relative humidity may not exceed 85% during placement. Kansas requires that portland cement concrete patches cure for a minimum of 28 days prior to applying the overlay, and also states that the prepared deck must be free of visible moisture prior to overlay placement. Wisconsin also recommends that at least 0.75 inches of the original deck be scarified to remove chlorides if the deck has been exposed to chlorides for more than 10 years.

Once the overlay is placed, it must be allowed to cure. California requires that the overlay be protected from moisture, traffic, and equipment loading for at least 4 hours after finishing. In Nebraska, a minimum curing time of 2 hours is required for polyester polymer concrete overlays and a compressive strength of at least 3000 psi must be achieved prior to opening to traffic. Similarly, Wisconsin specifies a curing time between 2 and 4 hours for polyester polymer concretes. Kansas requires that the curing time for an epoxy overlay be between 1 and 5 hours for the first course and 3 and 6.5 hours for the second course when the ambient temperature is between 55 and 85°F. If the temperature is below 55°F, then the curing time may increase to 8 hours. For polyester polymer, Kansas requires the curing time be between 0.5 and 2 hours.

A.3.5 Asphalt overlays

Asphalt overlays are currently specified by 5 states: Illinois, Michigan, Minnesota, Nebraska, and Wisconsin. Indiana used HMA with WPM systems in the 1960s and early 1970s, but because they experienced poor constructability and low reliability, Indiana no longer uses these systems. Similarly, Wisconsin commonly used HMA with WPM systems in the 1990s, but due to unreliable performance and inability to inspect the deck, Wisconsin has been using HMA with WPM systems on a limited basis since 2009. In contrast, Illinois always requires a waterproofing membrane be used with a HMA overlay and Nebraska requires a cold, liquid-applied membrane as well. Minnesota is the only state that does not use waterproofing membranes,

and Wisconsin is the only state to discuss miscellaneous asphalt overlays such as polymer-modified asphalt concrete.

Michigan, Minnesota, and Wisconsin all identify an HMA overlay without a waterproofing membrane as a short-term solution used to obtain the required ride quality until the deck is replaced within 5 years. Michigan states that asphalt overlays are generally not preferred treatments, and may only be used if the deck is to be replaced within 2 years. If life beyond 5 years is required, then a waterproofing membrane is required. Minnesota states that asphalt overlays are not only useful when maintaining rideability while deferring deck replacement, but also in minimizing surface repairs. According to the Wisconsin DOT, an HMA overlay can be expected to extend the service life of a bridge deck for 3 to 7 years and is a viable treatment for lightly-travelled decks scheduled for replacement within 4 years. In comparison, polymer-modified asphalt (PMA) overlays with a thermoplastic polymer modified additive can be expected to extend the service life by 10 to 15 years, but these overlays are relatively expensive. A HMA with WPM system may be expected to extend the life of the deck between 5 and 15 years.

Minnesota states that bituminous overlays between 2 and 4 inches thick should last a maximum of 5 years. In Nebraska, the minimum overlay thickness is 3 inches and a tack coat is applied between the waterproofing membrane and the HMA overlay to aid in bonding. Wisconsin requires an overlay thickness of at least 2 inches. Illinois has the smallest minimum overlay thickness of 1.25 inches, not including a 0.5-inch thick waterproofing membrane.

Regarding deck surface preparation, Minnesota specifies that 0.5 inches should be scarified from the deck and does not require removal of deteriorated concrete. However, Illinois states that the deck concrete should not be scarified before applying a waterproofing membrane and the deck should be cleaned using methods that do not roughen the surface.

APPENDIX B. SPECIFICATIONS FOR LATE LIFE DECK OVERLAYS

Appendix B.1 - Iowa DOT Special Provisions for Very High Early Strength Latex Modified Concrete Overlay

Appendix B.2 - Iowa DOT Special Provisions for Polyester Polymer Concrete Overlay

Appendix B.3 - Iowa DOT Special Provisions for Thin Polymer Concrete Overlay

Appendix B.4 - Draft Specifications for Hot Mixed Asphalt Overlay with Waterproofing Membrane

Appendix B.4.1 - Michigan DOT Standard Specifications Section 710. Waterproofing Membrane and Protective Covers

Appendix B.4.2 - Michigan DOT Qualified Waterproofing Membrane Products

Appendix B.4.3 - Nebraska DOT Special Provisions for Cold Liquid-Applied Membrane

Appendix B.5 - Draft Specifications for Hot Mixed Asphalt Overlay without Waterproofing Membrane

Appendix B.6 - Kentucky DOT Special Note for Asphalt Waterproofing Mix For Bridge-Deck Overlays

Appendix B.1 - Iowa DOT Special Provisions for Very High Early Strength Latex Modified Concrete Overlay



**SPECIAL PROVISIONS
FOR
VERY HIGH EARLY STRENGTH LATEX MODIFIED CONCRETE OVERLAY**

**Emmet County
BRFN-015-4(18)--39-32**

**Effective Date
November 20, 2018**

THE STANDARD SPECIFICATIONS, SERIES 2015, ARE AMENDED BY THE FOLLOWING MODIFICATIONS AND ADDITIONS. THESE ARE SPECIAL PROVISIONS AND THEY SHALL PREVAIL OVER THOSE PUBLISHED IN THE STANDARD SPECIFICATIONS.

150447.01 DESCRIPTION.

This specification consists of supplying, mixing, transporting, placing, finishing, and curing of Very High Early Strength Latex Modified Performance Concrete (VESLMC) for use as an overlay and riding surface in accordance with the Contract Documents and as directed by the Engineer. VESLMC is a cementitious material composed of granular constituents, a water-to-cementitious materials ratio less than 0.42 and a latex emulsion admixture.

150447.02 MATERIALS.

- A.** Provide materials in accordance with Division 41 of the Standard Specifications and as follows.
 - 1.** Coarse Aggregate – Use only those allowed in Article 4115.05 of the Standard Specifications.
 - 2.** Fine Aggregate – Use only those allowed in Section 4110 of the Standard Specifications.
 - 3.** Rapid Hardening Cement – Shall be approximately 33% calcium sulfoaluminate (C4A3S) and 67% dicalcium silicate (C2S) or other hydraulic cement that will provide a Latex Modified Concrete that meets the physical requirements of this specification. Fly ash or other pozzolanic materials are not permitted. Use a single source of cement for the project.
 - 4.** Latex Emulsion Admixture – Styrene butadiene in accordance with FHWA Report RD-78-35. Use a single source of latex for the project.
 - 5.** Other admixtures - Only as specified by the manufacturer.
- B.** The VESLMC mixture shall meet the material properties listed in Table 1: VESLMC Material

Properties, unless otherwise noted in the contract documents or as directed by the Engineer. Material properties listed below will be verified by the manufacturer and submitted for approval in the Placement Plan.

Description	Test Method	Acceptance Criteria
Compressive Strength <i>Ends of cylinders must be ground flush prior to testing. Saw cutting, capping, and use of neoprene pads are not permitted.</i>	AASHTO T22 (3" x 6" cylinders and 2" x 2" cubes) (150 psi/sec loading rate)	2500 psi at 3 hours, 3000 psi at 12 hours, 3500 psi at 24 hours, and ≥4500 psi at 28 days
Rapid Chloride Ion Penetrability	AASHTO T 277 / ASTM C 1202 (6 hour test)	≤ 1000 coulombs
Scaling Resistance	ASTM C672	Y < 2

The contractor shall submit a VESLMC mix design to the engineer for approval. The submittal shall include the name and location of aggregate suppliers, and the brand of cement and latex proposed for use. No concrete shall be placed prior to approval.

The VESLMC mixture shall contain the minimum proportions of the following materials:

- Cement – 658 pounds per cubic yard (94 pounds per bag)
- Latex Emulsion Admixture – 24.5 gallons per cubic yard
- Fine Aggregate – 210 to 255 pounds (50% to 60% by total weight) per bag of cement (1470 to 1785 pounds per cubic yard)
- Coarse Aggregate – 168 to 208 pounds per bag of cement (1176 to 1456 pounds per cubic yard)
- Net Water – 154 pounds per cubic yard. Net water shall be considered the quantity of mixing water added plus the non-solid portion of the latex.
- Admixtures containing calcium chloride shall not be used.

Properties of the latex modified concrete shall be as follows:

- Air Content – 0% to 7% maximum by volume of the plastic mix (air entraining admixtures shall not be added). The use of the latex manufacturers' recommended defoamer may be allowed as needed.
- Slump – 6 to 10 inches (measured 4 to 5 minutes after discharge from mobile mixer). During the waiting period the concrete shall not be disturbed.
- Water-Cement Ratio – Maximum 0.42, considering all non-solids as part of the mixing water and free water in aggregates as a part of total water cement ratio.

150447.03 CONSTRUCTION.

A. Storage.

Assure proper storage of all materials including but not limited to cement, aggregate, latex and additives, as required by the supplier's recommendation in order to protect the integrity of the materials against the loss of physical and mechanical properties.

B. Placement Plan.

1. Submit a Placement Plan with a detailed construction work schedule to the Engineer for review and approval at least 30 days prior to the scheduled VESLMC placement pour. The following list is intended as a guide and may not address all of the means and methods the contractor may elect to use. The Contractor is expected to assemble a comprehensive list of all necessary items for executing the placement of VESLMC.

- Responsible personnel and hierarchy.
- Equipment – including but not limited to mixers, holding tanks, generators, wheelbarrows, scales, meters, thermometers, floats, screeds, burlap, plastic, heaters, blankets, etc.
- Quality Control of batch proportions - including dry ingredients, latex, water and admixtures.
- Quality Control of mixing time and batch times.
- Batch procedure sequence.
- Form work – including materials and removal.
- Placement procedure – including but not limited to surface preparation of existing concrete surfaces and pre-wetting of the existing concrete interface to a saturated-surface-dry (SSD) condition before the placement of VESLMC, spreading, finishing, and curing protection. Include provisions for acceptable ambient conditions and batch temperatures and corrective measures as appropriate.
- Threshold limits for ambient temperature, ambient relative humidity, batch consistency, batch temperature, batch times and related corrective actions.

Placing and finishing equipment shall include a finishing machine, capable of covering large areas of work, which is self-propelled and capable of forward and reverse movement under positive control. Provisions shall be made for raising all screeds to clear the finished surface while traveling in reverse motion. The finishing machine shall consist of all appropriate finishing devices, including a vibrating pan, one or more rotating cylindrical rollers with augers or vibratory screed, drag pan, and wet burlap drag. The contractor shall provide all other hand tools necessary to distribute and strike off the latex modified concrete ahead of the finish machine.

At least two suitable lightweight wheeled work bridges will be required to aid in final finishing and curing of the LMC operation behind the finishing machine.

2. A preconstruction meeting will be held between the VESLMC manufacturer's representative, the Contractor's staff, and representatives from Iowa DOT District Office, Office of Bridges and Structures, and Office of Construction and Materials to review the Contractor's Placement Plan prior to placement of VESLMC materials. No VESLMC pour will be permitted until the aforementioned Placement Plan has been submitted by the contractor and approved by the Engineer.
3. Pumping of VESLMC is not allowed.
4. Construction loads applied to the bridge during VESLMC placement and curing are the responsibility of the contractor. Submit the weight and location of concrete placing equipment, grinding equipment or other significant construction loads for review as part of the proposed Placement Plan.

C. Forming, Mixing, Transporting, Placing and Curing.

1. Forming.

Design and fabricate formwork if required to adhere to Standard Specifications and the recommendations of the VESLMC manufacturer. Construct forms from nonabsorbent material that are properly sealed and capable of resisting the hydrostatic pressures from VESLMC in the unhardened state. Do not remove formwork until the VESLMC overlay undergoes a minimum 3 hour curing process and the minimum desired strength gain of 3000 psi is achieved.

2. Mixing and Transporting.

- a. A continuous volumetric type mobile mixer, calibrated to accurately proportion the

specified mix, shall be used to mix and discharge the VESLMC. The mixer shall be equipped with a flow meter for calibrating the water supply, and a cumulative-type meter that can be read to the nearest 0.1 gallon. The water meter shall be readily accessible, accurate to within 1%, and easy to read.

- b. The mixer shall have a self-contained latex system on the unit with dedicated on-board tank, mechanization system (drive shafts or hydraulic), recirculation system, relief valve, pumps, strainers, control valves, pressure gauge and flow meters.
 - c. Continuous type mixers that entrap unacceptable volumes of air in the mix shall not be used. The latex manufacturers' recommended defoamer may be allowed to reduce the air content. Batch type mixers, drum-type transit truck type mixers, rotating drum batch type mixers, or concrete mobile mixers without the self-contained latex system, shall not be used for mixing the LMC. Mixers that cannot consistently produce a uniform, thoroughly blended mix, within the specified design parameters shall be replaced.
 - d. The concrete shall be volumetrically mixed at the bridge site by a self-contained, self-propelled, continuous type mobile mixer calibrated to accurately proportion the specified mix. Sufficient mixing capacity or number of mixers (two minimum) shall be provided to permit the intended pour to be placed without interruption. The mixers shall be capable of carrying enough quantity of unmixed ingredient to produce at least 6 cubic yards of VESLMC at the bridge site. The mixer should be equipped with a grounding strap. Mobile mixers shall not be loaded more than 6 hours prior to placement.
 - e. The concrete discharged from the mixer shall be uniform in composition and consistency. The mixer shall also measure and control the flow of ingredients being introduced into the mix and shall record these quantities on a visible recording meter equipped with a ticket printer.
 - f. The flow of latex modifier shall be displayed by an approved flow meter. The latex system shall be equipped with a latex strainer to remove any solid particles during the operation of the mixer and provide positive control of the latex emulsion into the mixing chamber. The mixer shall be capable of continuously circulating the latex emulsion. At any time, the engineer may request random 1 quart latex samples be taken for testing from tankers or mobile mixers prior to placement on the deck.
 - g. Coarse and fine aggregates shall be conditioned to avoid variations in the moisture content affecting the uniform consistency of the concrete. Aggregate bins shall be clean, with sand bin vibrators in good working order.
 - h. Water flow shall be readily adjustable to compensate for minor variations in aggregate moisture content and be displayed by an approved flow meter.
 - i. The cement meter feeder fins and all pockets shall be clean and free of accumulated cement.
 - j. The cement aeration system shall be equipped with a gauge or indicator to verify the system is operating.
 - k. The main belt, latex strainer, and the auger shall be kept free of accumulated build ups, partially dried, or hardened material.
 - l. A complete calibration shall be performed for each mixer used at the work site prior to performing the work in accordance with Materials I.M. 534. Equipment shall also be required in accordance with the manufacturer's instructions for each specific admixture that may be required.
- 3. Yield Testing.**
- a. Yield testing shall be performed during the placement of LMC on the deck using a 1/4 cubic yard box (36 inches by 36 inches by 9 inches). The chute shall be clean of any LMC prior to discharge. The mixer shall be operated until the cement counter indicates 1/4 cubic yard of concrete has been produced, and the contents consolidated and struck off. If the box is not full, the gates shall be adjusted, and the procedure repeated until the actual and calculated volumes of concrete agree.
 - b. Yield tests shall be run on the first load of each truck and every third load per truck

thereafter. Additional tests will be required after making any adjustments.

4. Placement.

- a. The contractor shall provide documentation of having successfully placed a VESLMC overlay meeting this specification on at least three projects of similar size and scope within the last 5 years. Submit a list of projects with location of the bridge, name of latex manufacturer, approximate date of bridge opening to traffic, and owner contact information.
- b. The overlay shall not be placed unless the ambient temperature is 45°F and rising. The overlay shall not be placed if the ambient temperature or deck temperature is above 85°F. When daytime temperatures exceed 85°F, the contractor should consider placing the concrete during very early morning hours or at night. If rain is expected, have materials and procedures in place to bulkhead or protect the overlay surface from damage. Areas damaged by rain shall be replaced at the direction of the engineer, at no additional cost to the Contracting Authority.
- c. Before the overlay is placed on a surface undergoing rehabilitation, the entire milled or hydrodemolished deck surface, and any related vertical surfaces, shall be thoroughly cleaned by a minimum 7500 psi waterblast or sandblasting. All bonding surfaces shall be free of any laitance or foreign substance prior to the placement of the overlay.
 - Areas of Class A deck repair as defined in Article 2413.01 of the Standard Specifications and designated by the Engineer may be repaired using the VESLMC overlay system, as part of the overlay operation. If these areas will instead be repaired prior to the placement of the VESLMC overlay, they shall be allowed to cure properly and will be subject to the surface preparation of this specification.
 - Areas of Class B deck repair as defined in Article 2413.01 of the Standard Specifications and designated by the Engineer shall be repaired and allowed to cure prior to placement of the VESLMC overlay system. The repair areas shall be subject to the surface preparation of this specification. If use of VESLMC material for Class B deck repair right before overlay is desired, patching needs to be done 15 to 20 minutes before overlay course and make sure to vibrate material in lower patch and again with overlay.
- d. The cleaned surface shall be thoroughly wetted to the point where it will not dry out (minimum of 1 hour, but potentially more depending on weather conditions), then covered with polyethylene sheeting until time of concrete overlay placement. It is imperative that the deck is damp at the time of overlay placement, but any standing water in depressions or areas of concrete removal within the deck shall be removed prior to placement and remain free of standing water. The surface shall remain wet upon completion of surface preparation and the overlay placed within 24 hours. If the deck is allowed to dry out, it shall be reblasted at the contractor's expense.
- e. The VESLMC shall be placed only when the surface evaporation rate, as affected by ambient air temperature concrete temperature, deck temperature, relative humidity and wind velocity, is 0.1 pound per square foot per hour or less. The contractor shall determine and document atmospheric conditions. Refer to ACI 308 to determine graphically the loss of surface moisture for the overlay.
- f. A fogging system shall be in place prior to overlay placement. The fogging system shall consist of pressurized equipment that distributes water at a minimum rate of 0.10 gallons per hour per square foot. The fogging system shall apply the fog uniformly over the entire surface of the bridge deck. The fogging system shall produce atomized water that has a droplet with a maximum diameter of 0.003 inches and which keeps the finished deck surface saturated without producing standing water. The fogging system shall be started progressively along the length of the deck during or immediately after floating. The Contractor shall submit a letter certifying that their fogging system is in accordance with this provision.

- g.** During delays in the overlay placement operation of more than 10 minutes or when a plastic film develops on the VESLMC, the work face of the overlay shall be temporarily covered with wet burlap. If an excessive delay is anticipated, a bulkhead shall be installed at the face and the overlay operation terminated.

5. Curing.

- a.** The surface of the overlay shall be promptly covered with a single, clean layer of wet (presoaked for 24 hours) burlap, as soon as the finished surface will support it and not cause marring or deformation. The total wet curing period shall be until the minimum desired strength gain of 3000 psi is achieved, with a minimum of 3 hours. Minimum 4000 psi shall be attained in 24 hours. The overlay shall be moist cured from the time placed until open to traffic. No dry curing time is required.
 - b.** The burlap shall be kept continuously wet for the duration of the specified wet cure period. The wet burlap shall be promptly covered with opaque or white polyethylene sheeting for the entire duration of the wet cure. Wet curing shall be supplemented with soaker hoses, as required.
- 6.** Representatives of the VESLMC manufacturer knowledgeable in supplying, mixing, transporting, placing, finishing and curing of the VESLMC material must be present during mixing, transporting and placing of the VESLMC. The contractor will arrange for two manufacturer's representatives to be on site for the duration of the VESLMC construction; one representative will remain with the mixing operations and the second representative will remain with the placement operations. Do not start mixing or placing VESLMC until the manufacturer's representatives are on-site. Place VESLMC in accordance with the approved Placement Plan using one continuous pour per each stage of construction. Keep VESLMC from freezing until it has achieved a minimum compressive strength of 3500 psi minimum.
- 7.** The Contractor will arrange for an on-site meeting with the VESLMC manufacturer's representative one day before the start of the actual VESLMC placement. The Contractor's staff and representatives from Iowa DOT District Office, Office of Bridges and Structures, and Office of Construction and Materials, will attend the meeting. The objective of the meeting will be to clearly outline the procedures for mixing, transporting, finishing and curing of the VESLMC.

D. Acceptance Testing.

- 1.** The District Materials Engineer will be on site during the placement of VESLMC. To schedule a representative, contact the District a minimum of 48 hours prior to the anticipated VESLMC placement. Final acceptance will be based upon 28 day strength. Field coring of VESLMC for dispute resolution will not be allowed.
- 2.** The Contractor is responsible for providing an adequate location to place acceptance specimens for initial curing prior to transport to the lab. Compressive strength specimens shall be cured in the same environment as the in-place VESLMC for two hours minimum. Curing boxes will be equipped with supplemental heat as necessary to cure specimens in accordance with ASTM C31. Testing shall be performed by the Contractor and approved by the Engineer. Testing is summarized in Table 2: VESLMC Acceptance Testing. Performance frequencies of each test listed in Table 2, are a minimum value. Tests may be performed at more frequent intervals than described in Table 2, at the discretion of the Engineer.
- 3.** Once the mixers are calibrated, the VESLMC shall be sampled and tested for slump and air content. The Contractor shall prepare and test specimens to demonstrate that the concrete mixture shall obtain a compressive strength of 3000 psi prior to opening the road to traffic and

4500 psi at 28 days. All trial batching and preparation work prior to placing the VESLMC shall be at the Contractor's expense. During the placement of the overlay the Contractor shall take samples for testing.

Table 2: VESLMC Acceptance Testing			
Description	Test Method	Acceptance Criteria	Frequency
Compressive Strength	AASHTO T 22	≥ 4500 psi (at 28 days)* (3" x 6" cylinders) (150 psi/sec loading rate)	12 tests in 1 st day at intervals specified by engineer, 3 hour, 12 hour, 24 hour, 2 day, 4 day, 8 day, 14 day, & 28 day
Rapid Chloride Ion Penetrability	AASHTO T 277 / ASTM C 1202	≤ 1000 coulombs (4" x 8" cylinders)	Two per job (During field placement)
Slump Flow and Visual Stability	ASTM C1437 / ASTM C 1611	6 inches (Min.) 10 inches (Max.) No bleed water	One per batch

* Don't open the overlay to traffic until it undergoes a minimum 3 hour curing process and the minimum strength gain of 3000 psi is achieved.

E. Surface Profile and Finish.

1. The finished surface of the VESLMC overlay will match the proposed roadway profile to within a tolerance specified in Article 2413.03, E of the Standard Specifications. The extent of the required diamond grinding will be as directed by the Engineer. Grinding and longitudinal grooving can be performed after 24 hours after overlay pouring. Perform longitudinal grooving according to Article 2412.03, D of the Standard Specifications. Transverse grooving or tining in plastic concrete will not be allowed.
2. Traffic or other loading will not be permitted directly on the VESLMC overlay until the VESLMC undergoes the aforementioned 3 hour curing process and achieves a minimum compressive strength of 3000 psi, unless otherwise approved by the Engineer.

150447.04 METHOD OF MEASUREMENT.

The quantity of Deck Overlay (VESLMC) will be measured as the number of square yards of VESLMC placed and accepted. The area will be computed using the dimensions shown on the plans.

150447.05 BASIS OF PAYMENT.

- A. The quantity of VESLMC overlay will be paid at the Contract unit price per square yards. Price and payment will constitute full compensation for surface preparation, supplying, mixing, transporting, forming, placing, finishing, curing, grinding and for furnishing all equipment, tools, labor, and incidentals required to complete the work. Price and payment will also constitute full compensation for sealing the traffic barrier surfaces and replacing the top portion of the joints at both ends of the bridge as shown on the plans and in accordance with Article 2403.03, P, 3 of the Standard Specifications.
- B. Additional quantity of VESLMC material used in the determination of material properties and for acceptance testing as described herein will be furnished at no additional cost to the Contracting Authority. No additional payment will be made for surface preparation or for grinding procedures.
- C. Additional quantity of VESLMC material used to repair areas from hydrodemolition, grinding or

hand removals will be paid for separately as described in the Contract Documents.

- D.** If the VESLMC does not meet the minimal material properties as described herein, the VESLMC will be removed and replaced or remediated to the satisfaction of the Engineer at the Contractor's expense. No additional payment will be made for remedial solutions to insufficient bonding between the VESLMC and underlying bridge elements.

Appendix B.2 - Iowa DOT Special Provisions for Polyester Polymer Concrete Overlay



**SPECIAL PROVISIONS
FOR
POLYESTER POLYMER CONCRETE OVERLAY WITH HIGH MOLECULAR WEIGHT
METHACRYLATE RESIN PRIMER**

**Jasper County
IMN-080-5(336)164--0E-50**

**Linn County
IMN-380-6(301)21--0E-57**

**Effective Date
December 18, 2018**

THE STANDARD SPECIFICATIONS, SERIES 2015, ARE AMENDED BY THE FOLLOWING MODIFICATIONS AND ADDITIONS. THESE ARE SPECIAL PROVISIONS AND THEY SHALL PREVAIL OVER THOSE PUBLISHED IN THE STANDARD SPECIFICATIONS.

150453.01 DESCRIPTION.

This specification consists of supplying, mixing, transporting, surface preparation, placing, finishing, and curing of a Polyester Polymer Concrete (PPC) overlay with High Molecular Weight Methacrylate (HMWM) resin primer in accordance with the Contract Documents and as directed by the Engineer.

150453.02 MATERIALS.

PPC shall consist of polyester resin binder and aggregates with a compatible primer meeting the component and composite material properties specified. All components shall be supplied collectively through the same provider, qualified as defined herein, referred to as the System Provider.

A. Primer.

1. The prepared deck surface shall receive a wax-free, low odor HMWM primer consisting of a resin, initiator and promotor. HMWM shall meet the requirements of Table 1.

Table 1: HMWM Primer Resin Requirements

Property	Requirement	Test Method
Viscosity*	25 cps maximum	ASTM D 2196, Brookfield RVT with UL adapter, 50 RPM at 77°F
Volatile Content*	30% maximum	ASTM D 2369
Specific Gravity* (at 77°F)	0.90 minimum	ASTM D 1475

Flash Point*	180°F minimum	ASTM D 3278
Vapor Pressure* (at 77°F)	1.0 mm Hg maximum	ASTM D 323
PCC Saturated Surface-Dry Bond Strength, with primer** (24 hours and 70 ± 1°F)	700 psi minimum	California Test 551, part 5

* Test shall be performed before initiator is added.

** Initiated polyester concrete tested at 12% resin content by weight of dry aggregate.

2. The prime coat promoter/initiator shall consist of a metal drier and peroxide. If supplied separately from the resin, at no time shall the metal drier be mixed directly with the peroxide – a violent exothermic reaction will occur. The containers and measuring devices shall be stored in a manner that will not allow leakage or spillage from one material to contact the containers or material of the other.

B. Aggregate.

1. Aggregate for PPC shall meet the following requirements:
 - a. Singly crushed aggregate that is free of dirt, clay and foreign or organic material.
 - b. Aggregate retained on the No. 8 sieve shall have a maximum of 45% crushed particles when tested in accordance with AASHTO Test Method T335.
 - c. Fine aggregate shall consist of natural sand only.
 - d. Weighted average aggregate absorption shall not exceed 1.0% as determined by AASHTO Test Methods T84 and T85.
 - e. At the time of mixing with the resin, the moisture content of the aggregate, as determined by AASHTO Test Method T255, shall not exceed one half of the aggregate absorption.
 - f. Aggregate shall have a minimum Mohs hardness of 7.
 - g. Aggregate shall meet the gradation requirements in Table 2.

Table 2: PPC Aggregate Gradation Requirements

Sieve Size	Percent Passing
3/8 inch	100
No. 4	62-85
No. 8	45-67
No. 16	29-50
No. 30	16-36
No. 50	5-20
No. 100	0-7
No. 200	0-3

2. Sand used for abrasive sand finish shall meet the following properties:
 - a. Shall be a commercial-quality blast sand.
 - b. Shall not have less than 95% pass the No. 8 sieve and not less than 95% retained on the No. 20 sieve when tested under AASHTO T27.
 - c. Shall be dry at the time of application.

C. Polyester Resin Binder.

Provide a polyester resin binder meeting the following requirements:

1. Shall be an unsaturated isophthalic polyester-styrene co-polymer suitable for a polyester concrete mixture with a resin content of 12% ± 1% of the weight of the dry aggregate.
2. Shall contain at least 1% by weight gamma-methacryloxypropyltrimethoxysilane, an organosilane ester silane coupler.

3. Shall be used with a promoter that is compatible with suitable methyl ethyl ketone peroxide and cumene hydroperoxide initiators.
4. Shall meet the requirements in Table 3.

Table 3: Polyester Resin Binder Requirements

Property	Requirement	Test Method
Viscosity*	75 to 200 cps	ASTM D 2196 RVT No. 1 spindle, 20 RPM at 77°F
Specific Gravity*	1.05 to 1.10	ASTM D 1475
Styrene Content*	40-50% by weight	ASTM D 2369
Silane Coupler*	1.0% by weight	NMR Spectrum
Gel Time	30 to 60 minutes	ASTM C881 at 73°F
Elongation	35% minimum (Type I specimen, thickness 0.25± 0.03" at Rate = 0.45 inch/minute)	ASTM D 638
	Sample Conditioning: 18/25/50+5/70	ASTM D 618
Tensile Strength	2500 psi minimum (Type I specimen, thickness 0.25± 0.03" at Rate = 0.45 inch/minute)	ASTM D 638
	Sample Conditioning: 18/25/50+5/70	ASTM D 618

* Test shall be performed before initiator is added.

D. PPC Composite System.

The composite PPC system shall meet the requirements in Table 4.

Table 4: PPC Composite System Requirements

Property	Requirement	Test Method
PCC Saturated-Surface Dry Bond Strength, without primer* (24 hours and 70 ± 1°F)	500 psi minimum	CT 551
Abrasion Resistance	2g weight loss maximum	CT 550
Modulus of Elasticity	1000 to 2000 ksi	ASTM C 469

* Initiated polyester concrete tested at 12% resin content by weight of dry aggregate.

E. Packaging and Shipment.

Provide a Safety Data Sheet prior to use for each shipment of polyester resin binder and HMWM resin. All components shall be shipped in strong, substantial containers. Polyester resin binder and primer resin shall bear the System Provider's label specifying lot/batch number, brand name and quantity. In addition, the mixing ratio shall be provided to the Contractor by the System Provider prior to shipment.

F. Storage of Materials.

All materials shall be stored in a cool, dry location and in their original containers in accordance with the System Provider's recommendation to ensure their preservation until used in the work. The shelf life for liquid materials stored out of direct sunlight and at temperatures 80°F and below shall be at least 12 months. All aggregates shall be stored in a clean, dry location away from

moisture. Applicable fire codes may require special storage facilities for some components of the overlay system.

150453.03 CONSTRUCTION.

A. Contractor Qualifications.

The contractor shall provide documentation of having successfully placed a complete PPC overlay system meeting this specification on at least three projects of similar size and scope within the last 5 years. Submit a list of projects with location of the bridge, name of System Provider, approximate date of bridge opening to traffic, and owner contact information.

B. Placement Plan.

1. Submit a Placement Plan with a detailed construction work schedule to the Engineer for review and approval at least 30 days prior to the scheduled PPC overlay placement. The following list is intended as a guide and may not address all the means and methods the contractor may elect to use. The Contractor is expected to assemble a comprehensive list of all necessary items for executing the placement of the PPC overlay.
 - a. Responsible personnel and hierarchy.
 - b. Equipment – including but not limited to mixers, holding tanks, generators, wheelbarrows, scales, meters, thermometers, floats, screeds, burlap, plastic, heaters, blankets, etc.
 - c. Quality Control of batch proportions - including dry ingredients, polyester resin binder, water and admixtures.
 - d. Quality Control of mixing time and batch times.
 - e. Batch procedure sequence.
 - f. Form work – including materials and removal.
 - g. Placement procedure – including but not limited to surface preparation of existing concrete surfaces, application and spreading of HMWM primer, and spreading, finishing, and curing of PPC overlay. Include provisions for acceptable ambient conditions and batch temperatures and corrective measures as appropriate.
 - h. Threshold limits for ambient temperature, ambient relative humidity, batch consistency, batch temperature, batch times and related corrective actions.
2. A preconstruction meeting will be held between the PPC overlay manufacturer's representative, the Contractor's staff, and representatives from Iowa DOT District Office, Office of Bridges and Structures, and Office of Construction and Materials to review the Contractor's Placement Plan prior to placement of the PPC overlay. No PPC overlay pour will be permitted until the aforementioned Placement Plan has been submitted by the contractor and approved by the Engineer.
3. Construction loads applied to the bridge during PPC overlay placement and curing are the responsibility of the contractor. Submit the weight and location of concrete placing equipment, grinding equipment or other significant construction loads for review as part of the proposed Placement Plan.

C. Equipment.

Equipment is subject to approval by the Engineer and must comply with the following requirements.

1. General.

Provide an overall combination of labor and equipment with the capability of proportioning and mixing the PPC components, and placing the HMWM primer and PPC overlay in accordance with this specification and the manufacturer's recommendations.

2. Surface Preparation Equipment.

- a. Shot-blasting equipment capable of removing all loose, disintegrated concrete, dirt, paint, oil, asphalt, laitance carbonation and curing materials, grease, slurry, or rust from the deck surface.
- b. Automatic shot-blasting units shall be self-propelled and include a vacuum to recover spent abrasives. The abrasive shall be steel shot.
- c. In areas inaccessible to shot-blasting equipment, the surface may, with the Engineer's approval, be cleaned with sandblasting equipment.

3. **Mixing Equipment.**

Polyester concrete shall be mixed in either mechanically operated mixers or continuous automated mixers meeting the following requirements:

- a. Employ an auger screw/chute device capable of completely blending catalyzed binder resin and aggregates.
- b. Employ a plural component pumping system capable of handling polyester binder resin and catalyst, adjustable to maintain proper ratios to achieve set/cure times within the specified limits.
- c. Be equipped with an automatic metering device that measures and records aggregate and resin volumes. Record volumes at least every 5 minutes, including time and date. Submit recorded volumes at the end of shift.
- d. Have a visible readout gage that displays volumes of aggregate and resin being recorded.
- e. Produce a satisfactory mix consistently during the entire application process.
- f. Be calibrated per Caltrans California Test CT 109 or similar. Submit current certificate of calibration to the Engineer.

4. **Application and Finishing Equipment.**

Polyester concrete shall be placed by a vibratory screed on preset forms or rails or by self-propelled slip-form paving machine, which is modified or specifically built to effectively place PPC overlays in a manner meeting the following requirements:

- a. Employ a vibrating pan to consolidate and finish the PPC overlay.
- b. Be fitted with hydraulically controlled grade automation to establish the finished profile. The automation shall be fitted with substrate grade averaging devices on both sides of the new placement; the device shall average 15 feet in front and behind the automation sensors; or the sensor shall be constructed to work with string-line control. It is acceptable to match grade when placing lanes adjacent to previously placed polyester overlay.
- c. Have sufficient engine power and weight to provide adequate vibration of the finishing pan while maintaining consistent forward speed.
- d. Be capable of forward and reverse motion under its own power.
- e. The contractor shall provide all other hand tools necessary to distribute and strike off the PPC overlay ahead of the finish machine.

D. **Surface Preparation.**

All surfaces that will be in contact with the overlay shall be prepared by shotblasting in order to remove all existing loose, disintegrated concrete, dirt, paint, oil, asphalt, laitance carbonation and curing materials, grease, slurry, rust or any other contaminants that could interfere with the proper adhesion of the overlay system.

The final prepared surface shall meet the following requirements:

- 1. Areas to receive the PPC overlay shall be cleaned by shotblasting. In the event the shotblaster cannot access certain areas, cleaning may be done by an abrasive sandblasting, with the Engineer's approval. Cleaning shall not commence until all work involving the repair of the concrete substrate surface has been completed and repair materials have cured. All

contaminants shall be picked up and stored in a vacuum unit, and dust shall not be created during the cleaning operation that will obstruct the view of motorists.

2. The Contractor shall determine the size of shot, flow of shot, forward speed of shot blast machine and number of passes necessary to provide a surface free of weak or loose surface mortar, exposing the aggregates within the substrate concrete and visibly changing the color of the substrate concrete. Mortar which is sound and firmly bonded to the coarse aggregate must have open pores due to cleaning to be considered adequate for bond.
3. Cleaned surfaces shall not be exposed to vehicular traffic unless required by the overlay operation and approved by the Engineer. Cleaned concrete substrates that have been contaminated such that contaminants might interfere with the bonding or curing of the overlay must be cleaned to the satisfaction of the Engineer prior to placing the overlay at no additional cost to the Department. The cleaned concrete substrate shall be dry at the time of application of the primer and overlay.
4. All steel surfaces that will be in contact with the overlay shall be cleaned in accordance with SSPC-SP No. 10, Near-White Blast Cleaning, except that wet blasting methods shall not be allowed.
5. Areas of Class A deck repair as defined in Article 2413.01 of the Standard Specifications and designated by the Engineer may be repaired using the PPC overlay system, as part of the overlay operation. If these areas will instead be repaired prior to the placement of the PPC overlay, they shall be allowed to cure properly and will be subject to the surface preparation of this specification.
6. Areas of Class B deck repair as defined in Article 2413.01 of the Standard Specifications and designated by the Engineer shall be repaired and allowed to cure prior to placement of the PPC overlay system. The repair areas shall be subject to the surface preparation of this specification. Use of PPC overlay for Class B deck repair is not allowed.

E. Trial Application.

1. Prior to constructing the overlay, a trial application of the PPC overlay shall be placed on the prepared substrate to demonstrate proper initial set time and the effectiveness of the surface preparation, mixing, placing and finishing equipment proposed. The trial application shall be at least 10 feet long and at the planned paving width and specified overlay thickness. The location(s) of the trial application shall be approved by the Engineer.

If the cleaning practice, materials, installation, finishing and/or texturing are not acceptable, the Contractor shall remove the failed trial application and reinstall the trial application at no additional cost to the Department until satisfactory results are obtained.

The number of trial applications required shall be as many as necessary for the Contractor to demonstrate the ability to construct an acceptable trial overlay section and competency to perform the work. The installer, System Provider and/or proposed equipment/techniques may be rejected by the Engineer if not shown to be acceptable after three failed trial applications.

2. Direct Tension Bond Test shall be performed 24 hours after the placement of the trial application in accordance with ASTM C 1583 to assure that the overlay adheres to the prepared surface. The test result shall be the average of two successful tests. Test cores shall be drilled through the overlay and into the substrate a minimum of 0.25 inches.

The minimum direct tension bond strength shall be 250 psi. An acceptable test will demonstrate that the overlay bond strength is sufficient by producing a concrete subsurface failure area greater than 50% of the test area. The Contractor shall repair all bond test locations with polyester concrete in accordance with this specification.

F. Placing and Finishing.

1. General.

- a.** Representatives of the System Provider knowledgeable in supplying, mixing, transporting, placing, finishing and curing of the PPC system, including the HMWM primer, must be present during placement. Do not start mixing or placing the primer or PPC overlay until the manufacturer's representatives are on-site.
- b.** Application of the HMWM primer and placement of PPC overlay shall not begin until the substrate is visibly surface dry, and free of water and moisture. ASTM D 4263 modified for 2 hours may be used to verify dryness at the discretion of the Engineer in cases when surface dryness is difficult to determine.
- c.** The ambient and substrate surface temperature shall be between 40°F to 100°F at the time of primer and PPC overlay placement. Night work may be required when temperatures cannot be met during the day.
- d.** Application of HMWM primer and placement of PPC overlay shall not commence if rain is forecast.

2. Prime Coat.

- a.** Prior to applying the HMWM prime coat, the area shall be completely dry and blown clean with oil-free compressed air.
- b.** Primer shall be mixed and applied in accordance with the System Provider's recommendations. Primer shall be applied within 5 minutes of mixing initiator and resin at a rate of approximately 90 to 100 square feet per gallon, or as otherwise recommended by the System Provider.
- c.** Primer shall be applied by flooding and uniformly spread to completely cover all surfaces to receive overlay, including any adjacent vertical surfaces. Care should be taken to avoid heavy application that results in excess puddling. Excess material shall be removed or distributed to meet the recommended application rate. Primer shall be reapplied to any areas that appear visibly dry prior to overlay placement.

3. Polyester Polymer Concrete.

- a.** PPC shall be mixed and applied in accordance with the System Provider's recommendations.
- b.** PPC shall be applied after 15 minutes and within 2 hours of placing the primer and shall be placed prior to gelling or within 15 minutes following addition of the initiator, whichever occurs first, or as recommended by the System Provider.
- c.** The PPC mixture shall have an initial set time of ≥ 30 minutes and ≤ 90 minutes, when the in-place PPC cannot be deformed by pressing with a finger. If the initial set is not within 30 to 90 minutes, the material shall be removed and replaced at no additional cost.
- d.** PPC shall be consolidated and finished using placement equipment as defined herein to strike it off to the required grade and cross-section as shown in the contract documents, to within a tolerance specified in Article 2413.03, E of the Standard Specifications. Termination edges of the overlay may require application and finishing by hand trowel due to obstructions, such as curbs.
- e.** Apply abrasive finish sand evenly on the finished overlay surface at a rate of at least 2.2 pounds per square yard by broadcasting, immediately after the overlay placement before gelling.

- f. Wait a minimum of 24 hours for any surface correction grinding or longitudinal grooving. Perform longitudinal grooving according to Article 2412.03, D, 4, a of the Standard Specifications. Transverse grooving or tining in plastic concrete will not be allowed.

G. Curing.

1. The PPC overlay shall be allowed to cure sufficiently before being subjected to loads or traffic of any nature that may damage the overlay. Cure time is dependent on ambient and substrate temperatures and also initiator/accelerator levels used at the time of mixing. No wet curing or curing compound is necessary or allowed.
2. The overlay shall be considered cured to a traffic ready state after 4 hours following finishing or when a minimum reading of 25 on a properly calibrated Schmidt/Rebound hammer is achieved per ASTM C 805, whichever occurs first.

H. Acceptance Testing.

1. Contractor shall notify the District at least 48 hours prior to anticipated placement to allow them the opportunity to view the operation.
2. Testing shall be performed by the Contractor and approved by the Engineer. Testing is summarized in Table 5. Performance frequencies of each test listed are a minimum value and may be performed at a more frequent interval at the discretion of the Engineer.

Table 5: PPC Acceptance Testing

Description	Test Method	Acceptance Criteria	Frequency
Compressive Strength	ASTM C 805	Minimum reading of 25 using Schmidt/Rebound Hammer (3000 psi)	Per ASTM C 805 for each overlay application
Direct Tension Bond (after 24 hour cure)	ASTM C 1583	≥ 250 psi, and concrete subsurface failure area greater than 50% of the test area	2 tests per overlay application

150453.04 METHOD OF MEASUREMENT.

The quantity of Deck Overlay (PPC) will be measured as the number of square yards of PPC placed and accepted. The area will be computed using the dimensions shown on the plans.

150453.05 BASIS OF PAYMENT.

- A. The quantity of PPC overlay will be paid at the Contract unit price per square yards. Price and payment will constitute full compensation for surface preparation, supplying, mixing, transporting, forming, placing, finishing, curing, grinding and for furnishing all equipment, tools, labor, and incidentals required to complete the work. Price and payment will also constitute full compensation for sealing the traffic barrier surfaces and replacing the top portion of the joints at both ends of the bridge as shown on the plans and in accordance with Article 2403.03, P, 3 of the Standard Specifications.
- B. Additional quantity of PPC material used in the determination of material properties as described herein will be furnished at no additional cost to the Contracting Authority. No additional payment will be made for surface preparation or for grinding procedures.

- C.** Additional quantity of PPC material used for Class A deck repair areas, as defined by Article 2413.01 of the Standard Specification and designated by the Engineer, will be paid for separately.
- D.** If the PPC overlay does not meet the minimal material properties as described herein, it will be removed and replaced or remediated to the satisfaction of the Engineer at the Contractor's expense. No additional payment will be made for remedial solutions to insufficient bonding between the PPC overlay and underlying bridge elements.

Appendix B.3 - Iowa DOT Special Provisions for Thin Polymer Concrete Overlay



**SPECIAL PROVISIONS
FOR
MULTI-LAYER POLYMER CONCRETE OVERLAY**

**Black Hawk County
IMN-0380-7(122)68--0E-07**

**Effective Date
October 10, 2016**

THE STANDARD SPECIFICATIONS, SERIES 2015, ARE AMENDED BY THE FOLLOWING MODIFICATIONS AND ADDITIONS. THESE ARE SPECIAL PROVISIONS AND THEY SHALL PREVAIL OVER THOSE PUBLISHED IN THE STANDARD SPECIFICATIONS.

150132.01 DESCRIPTION.

Prepare the surface of the existing reinforced concrete bridge deck, and construct a multi-layer polymer concrete overlay for bridge preservation.

150132.02 MATERIALS.

A. Epoxy.

1. Provide an AASHTO M 325 Type III, Grade 1 or 2, 100% solids, thermosetting, moisture-insensitive epoxy with the following additional requirements of Table 150132.02-1:

Table 150132.02-1: Epoxy Requirements

Property	Requirement	Test Method
Viscosity	7-25 poises	ASTM D 2393, Brookfield RVT, Spindle no. 3 at 20 RPM
Gel Time	14-45 minutes	ASTM C 881, para. 11.2.1 modified, 50 to 100 ml sample
Compressive Strength*, 3 hr.	1000 psi min.	ASTM C 109, w/ plastic inserts
Compressive Strength*, 24 hr.	5000 psi min.	ASTM C 109, w/ plastic inserts
Tensile Strength, 7 day	2000-5000 psi	ASTM D 638
Elongation, 7 days	30-70 percent	ASTM D 638
Adhesive Strength, 24 hr.	250 psi min.	ACI 503R, Appendix A

*Mixed with aggregate

2. The epoxy formulation supplied must have a minimum application history of 3 years in a state or states in the northern half of the U.S. Include a list of bridges on which the material has been applied, the name of the owner agency and a contact at the owner agency for each structure submitted. Provide independent laboratory reports documenting that the epoxy binder meets the requirements of this section.

3. Provide the Engineer with a copy of the epoxy materials manufacturer's installation recommendations.

B. Aggregate.

Provide singly crushed aggregate that is free of dirt, clay and foreign or organic material and meets the requirements of Table 150132.02-2 and Table 150132.02-3.

Table 150132.02-2: Aggregate Requirements

Property	Requirement	Test Method
Sodium Sulfate Soundness, Max loss	0.12	AASHTO T104
Wear, Maximum	30%	AASHTO T96
Acid Insoluble Residue, Minimum	55%	ASTM D 3042
Fine Aggregate Angularity, Minimum	45%	AASHTO T304
Moisture Content, Maximum	0.20%	IM 381

Table 150132.02-3: Gradation Requirements for Aggregates

Sieve	Percent Passing
3/8"	100
No. 4	100
No. 8	30-75
No. 16	0-5
No. 30	0

150132.03 CONSTRUCTION.

This procedure may involve hazardous materials, operations and equipment.

A. Contractor Qualifications.

The contractor shall have at least 3 years experience applying multi-layer polymer concrete overlays. Submit a list of projects with owner contact information for multi-layer polymer concrete overlay projects placed within the past 3 years.

B. Equipment.

Equipment is subject to approval of the Engineer and must comply with these requirements.

1. General.

Provide an overall combination of labor and equipment with the capability of proportioning and mixing the epoxy components, and placing the epoxy and aggregate in accordance with this specification and the manufacturer's recommendations.

2. Surface Preparation Equipment.

- a. Shot-blasting equipment capable of removing all loose disintegrated concrete, dirt, paint, oil, asphalt, laitance carbonation and curing materials from the deck surface.
- b. Sandblasting equipment capable of removing all oxidation, dirt, paint, oil and asphalt from the metal expansion joints.

3. Mechanical Application Equipment.

- a. An epoxy distribution system capable of accurate and complete mixing of the epoxy resin and hardening agent, verification of the mix ratio and uniform and accurate distribution of the epoxy materials at the specified rate on 100% of the work area;
- b. A mechanical aggregate spreader capable of uniform and accurate application of the dry aggregate over 100% of the work area;
- c. An air compressor capable of producing a sufficient amount of oil free and moisture free compressed air to remove all dust and loose material; and

- d. Adequate additional hand tools to facilitate the placement of the surface treatment according to this specification and the manufacturer's recommendations.
4. Do not use power driven tools heavier than a 15 pound chipping hammer, during deck preparation.

C. Proportioning.

1. Proportion all epoxy materials according to the manufacturer's recommendations.
2. Follow all manufacturer suggested safety precautions while mixing and handling epoxy components.

D. Preparation of Surface.

1. Before preparation of the surface remove deteriorated concrete and repair the area with suitable patch material, as per the Developmental Specifications for Partial Depth Bridge Patching. Portland cement concrete patches require a minimum cure period of 28 days before application of the overlay.
2. As the final preparation for the placement of the surface treatment, make a complete cleanup by shot blasting and/or other approved means, followed by an air blast with dry, oil free air or vacuum. Brooming is not acceptable. Remove all loose disintegrated concrete, dirt, paint, oil, asphalt, laitance carbonation and curing materials from patches and other foreign material from the surface of the deck.
3. Produce a surface relief equal to the International Concrete Repair Institute (ICRI) Surface Preparation Level 6 or 7 or ASTM E 965 Pavement Macrotexture Depth of 0.04 to 0.08 inch. The following Tensile Rupture test will determine if additional surface preparation is necessary. Tensile Rupture tests shall be performed by the Contractor and observed by the Engineer.
 - a. Place a polymer concrete test patch a minimum of 0.5 square yards for each bridge deck surface or every 300 square yards of prepared deck surface, whichever is smaller. The test patch shall be full depth, placed by the normal construction sequence. The Engineer may waive the test patch and permit the Tensile Rupture tests to be performed on the finished surface at a location near the bridge rail. After testing, the Contractor will be required to fill the test locations with epoxy and aggregate.
 - b. Final acceptance will be based on the following results of the test outlined in ACI 503R Appendix A:
 - Minimum Tensile Rupture Strength of 250 psi from an average of three tests on a test patch regardless of depth of failure; or
 - Failure in the concrete at a depth greater than or equal to 1/4 inch over more than 50% of the test area for three of the four tests in the test patch.
 - c. If failure in the concrete is at a depth less than 1/4 inch and the Minimum Tensile Rupture Strength is less than 250 psi, or the failure in the concrete is less than 50% of the test area, additional surface preparation is necessary.
 - d. A failure in the concrete below 250 psi and greater than 1/4 inch deep indicates weak concrete, not poor polymer concrete bond.
 - e. Do not perform tensile adhesion tests when temperatures are above 85°F.
4. Remove any contamination of the prepared deck surface or surface of subsequent courses. Sand blast or bush hammer contaminated areas to produce an acceptable surface for placement of the surface treatment.
5. Protect any areas of the bridge deck that are not to be treated from the shot blast.

6. Close deck drains so the epoxy and aggregate shall not pass through the drains.
7. Rain will not necessarily contaminate the surface. However, care must be taken so no contamination occurs.
8. Visible moisture on the prepared deck at the time of placing the surface treatment is unacceptable. Identify moisture in the deck by taping a plastic sheet to the deck for a minimum of 2 hours (ASTM D 4263). Moisture tests shall be performed by the Contractor and observed by the Engineer.
9. Place the surface treatment within 24 hours of preparing the deck surface. Deck surfaces exposed for more than 24 hours must be sand blasted prior to application of the surface treatment.
10. The use of scarifiers, scrablers or milling machines will not be allowed unless approved by the Engineer.
11. Wet sand blasting shall not be allowed.
12. Sandblast expansion joints prior to placing surface treatment. Mask off all gaps in expansion joints to prevent epoxy and aggregate from collecting in joints.

E. Placing the Polymer Concrete Overlay.

1. Place the polymer concrete overlay to the grades, thickness and cross sections as shown in the contract documents. Provide a technical representative of the epoxy manufacturer on the job site during the placement of the surface treatment. The representative is to provide technical expertise to the Contractor and the Engineer regarding safe handling, placement and curing of the surface treatment.
2. Follow all manufacturer suggested safety precautions while mixing and handling epoxy components. Place the overlay in two separate courses at the application rates shown in table 150132.03-1.

Table 150132.03-1: Polymer Concrete Overlay Application Rates

Course	Epoxy Rate	Aggregate Rate*
1	Not less than 0.22 gal./sq yd	10 lbs./sq yd
2	Not less than 0.45 gal./sq yd	14.5 lbs./sq yd

*Apply enough aggregate to completely cover the epoxy

3. Use notched squeegees or mechanical application equipment to place the prepared epoxy on the deck immediately and uniformly at the prescribed rate. If mechanical application equipment is used, take 2 ounce samples for each 100 gallons of material placed to verify mix ratios and curing times. Place samples on the bridge rail or deck and note time to cure.
4. Use a paintbrush or roller to apply the epoxy on the face of curbs to the top of the curb. On bridges with continuous concrete barrier rails apply the epoxy to the first break in the geometry of the barrier to a minimum height of 6 inches above the deck. Apply the epoxy to the curb or barrier as each of the overlay applications are performed.
5. The bridge deck and all epoxy and aggregate components must be a minimum of 60°F at the time of application.

6. Apply the dry aggregate to cover the epoxy completely within 10 minutes of application. Remove and replace any first course areas that do not receive enough aggregate before gelling of the epoxy occurs.
7. Vacuum or broom excess aggregate from the first course after sufficiently cured. If damage or tearing occurs stop brooming or vacuuming.
8. Do not open the first course to traffic.
9. Place the epoxy and aggregate for the second course at the prescribed rate and in the same manner as the first course. Second course areas that do not receive enough aggregate before gelling of the epoxy may be re-coated with epoxy and aggregate.
10. Locate any longitudinal joints along lane lines, or as approved by the Engineer. Keep the joints clear of wheel paths as much as practical.
11. Produce and place the overlay within the specified limits in a continuous and uniform operation.
12. Correct surface variations exceeding 1/4 inch in 10 feet unless directed otherwise by the Engineer.
13. Tape all construction joints to provide a clean straight edge for adjacent polymer concrete placement. This includes joints between previously placed polymer overlay materials and at centerline.
14. Finish the exposed edges at the ends of the bridge and at expansion joints to minimize bridge deck roughness.
15. Apply a bond breaker to all expansion joints.
16. Remove masking material from expansion joints as soon as practical after aggregate application to ensure binder does not harden and bond the masking material to the joints.

F. Curing.

1. Minimum curing times are noted in Table 150132.03-2.

Table 150132.03-2: Polymer Concrete Overlay Cure Times

Course	Average Temperature of Overlay Components, ° F						
	55-59	60-64	65-69	70-74	75-79	80-85	85+
Minimum Cure Time (hours)							
1	5	4	3	2.5	2	1.5	1
2	6.5	6.5	5	4	3	3	3

2. Cure the second course for 8 hours if the air temperature falls below 55°F during the curing period.
3. Plan and perform the work in such a way as to provide for the minimum curing times as specified in this specification or as specified by the material manufacturer.

G. Weather Limitations.

1. Do not place the polymer concrete prior to April 1 or after September 30. The polymer concrete may be placed outside of the allowable dates with approval of the Engineer and the material supplier.
2. Do not place the overlay when conditions are such that the deck temperature will exceed 100°F.
3. Do not place the overlay if conditions are such that gel time is less than 10 minutes.
4. Do not place the overlay if the air temperature is expected to drop below 55°F within 8 hours of placement.

H. Correction of Unbonded or Damaged Areas.

Repair areas discovered to be unbonded (by tapping or chaining) and areas of the overlay damaged by the Contractor's operation. Saw cut the unbonded or damaged areas to the top of the deck surface, remove the overlay with small air tools (15 pounds maximum) or shotblasting. Shotblast the concrete bridge deck surface at the unbonded area to remove contaminants, and replace the overlay according to these specifications at no additional compensation.

150132.04 METHOD OF MEASUREMENT.

The Engineer will measure the area of Multi-Layer Polymer Concrete Overlay placed in square yards.

150132.05 BASIS OF PAYMENT.

Payment for Multi-Layer Polymer Concrete Overlay will be at the contract unit price per square yard. Payment is full compensation for the specified work, including preparation of the bridge surface (including expansion joints), furnishing and applying the epoxy, furnishing and applying the aggregate, and any corrective action required.

Appendix B.4 - Draft Specifications for Hot Mixed Asphalt Overlay with Waterproofing Membrane

SECTION XXXX. BRIDGE DECK ASPHALT OVERLAY WITH WATERPROOFING MEMBRANE USING STANDARD PROCEDURE

1.01 Description

These specifications describe requirements for an asphalt overlay with waterproofing membrane on an existing reinforced concrete deck. Apply Section 2303 of the Standard Specifications unless otherwise directed in these specifications.

1.02 Materials

5. Waterproofing Membrane

The waterproofing membrane shall be either preformed or cold-applied liquid.

1. Preformed Waterproofing Membrane:
 - a. See Michigan DOT Standard Specifications Qualified Products List for preformed waterproofing membrane materials, including a manufacturer-specified surface primer.
2. Cold-applied Liquid Waterproofing Membrane:
 - a. Apply Nebraska DOT Bridge Office Policies and Procedures, Section 5.G39 – Cold Liquid-Applied Membrane for material requirements.

6. Hot Mixed Asphalt (HMA) Overlay

Apply Section 2303 of Iowa DOT Standard Specifications for material requirements.

1.03 Construction

1. Surface Preparation

1. Remove existing deck overlay and clean deck surface in accordance with Section 2413. of the Iowa DOT Standard Specifications.
2. Repair areas of Class A deck repair as defined in Article 2413.01 of the Standard Specifications and designated by the Engineer.
3. Repair areas of Class B deck repair as defined in Article 2413.01 of the Standard Specifications and designated by the Engineer.

2. HMA Overlay with Preformed Waterproofing Membrane:

1. Membrane System Placement:
 - a. Apply Michigan DOT Standard Specifications Section 710.03.C.
2. Hot Mixed Asphalt Overlay
 - b. Apply Section 2303 of the Standard Specifications for construction of HMA overlay.

3. HMA Overlay with Cold-applied Liquid Waterproofing Membrane:

1. Membrane System Placement:
 - a. Apply Nebraska DOT Bridge Office Policies and Procedures, Section 5.G39 – Cold Liquid-Applied Membrane.

2. Hot Mixed Asphalt Overlay:
 - a. Apply Section 2303 of the Iowa DOT Standard Specifications for construction of HMA overlay.

1.04 Method of Measurement

The unit of payment for the Preformed Waterproofing Membrane is Square Foot.

The unit of payment for the Cold Liquid-Applied Membrane is Square Foot.

Hot Mix Asphalt Overlay will be measured according to Article 2303.04 of the Standard Specifications.

1.05 Basis of Payment

Hot Mix Asphalt Overlay will be paid for according to Article 2303.05 of the Standard Specifications.

Appendix B.4.1- Michigan DOT Standard Specifications Section 710. Waterproofing Membrane and Protective Covers

710.01

Section 710. WATERPROOFING AND PROTECTIVE COVERS

710.01. Description. This work consists of providing and placing membrane waterproofing and protective covers.

710.02. Materials. Provide materials in accordance with the following:

Water	911
Joint and Waterproofing Materials.....	914
Mortar and Grout	702

Provide one of the following waterproofing types as required.

A. **Preformed.** Preformed waterproofing membrane and expansion joint waterproofing selected from the Qualified Products List; including a manufacturer-specified surface primer.

B. **Shotcrete.** Shotcrete material consisting of a premixed, latex-modified portland cement, and fine aggregates, as recommended by the manufacturer for use as a pneumatically applied concrete; secure the Engineer's approval, before use on the project.

710.03. Construction.

A. **Joint Waterproofing – Preformed.** Where concrete joints require waterproofing, use preformed waterproofing.

Provide preformed joint waterproofing at least 18 inches wide.

Apply the preformed waterproofing membrane system to the concrete surface at least 4 hours after removing the forms.

Prepare and prime the surface for at least 12 inches on each side of the joint. Complete preparatory work if the air and concrete temperatures are above 40 °F and the surfaces are dry. Clean the surface, designated for coverage, by using a solvent and scraping to remove deleterious materials, including oil, grease, old waterproofing material, and asphalt residue.

Before applying the primer, remove protrusions that could puncture the membrane, or cause a void with a diameter greater than 3/4 inch. Remove dust from the concrete surface with compressed, oil-free air. Fill surface imperfections, potholes and spalls with a Department-approved epoxy mortar, mortar, or concrete and cure. Cure cement-based patching mixtures at least 24 hours before installing the membrane.

Apply the primer with a roller or brush, in accordance with the manufacturer's recommendations, over the entire concrete surface

required for membrane coverage. Provide an additional application of primer if the membrane is not placed within the time specified by the membrane system manufacturer.

Apply the membrane in accordance with the manufacturer's recommendations. Remove the release paper from the back surface of the membrane immediately before placing. Center the membrane over the concrete joint, straight and wrinkle-free. Immediately after applying each sheet, hand roll with a roller, using pressure necessary to remove air voids and ensure complete adhesion. Overlap seams at least 6 inches.

Before backfilling, demonstrate to the Engineer that the entire surface of membrane has fully adhered to the underlying concrete surface. The Engineer may reject waterproofing membrane systems that exhibit a loss of adhesion to the concrete surface. Repair punctures, tears, wrinkles, or other imperfections in the installed membrane. Make repairs by applying a patch of membrane over the damaged material, or remove and replace the membrane. Size patches to extend 6 inches beyond the perimeter of the repair area.

B. Expansion Joint Waterproofing – Preformed. Apply a two-layer, preformed joint waterproofing membrane system at integral and semi-integral abutment backwall locations. Apply expansion joint waterproofing in accordance with subsection [710.03.A](#), except as modified by this subsection [710.03.B](#)

Provide a preformed waterproofing membrane that is at least 18 inches wide.

Do not apply primer to the two beveled surfaces next to the expansion joint at the interface of the abutment wall and backwall, required to receive the bond breaker tape.

Apply a bond breaker tape, or equivalent material, to the face of each beveled surface next to the expansion joint at the interface of the abutment wall and backwall, to prevent the membrane fold from adhering to these concrete surfaces.

Center the membrane over the concrete joint, making it straight and wrinkle-free, and insert it full-depth into the beveled cavity of the expansion joint to provide slack in the membrane for bridge movement.

Apply a second layer of membrane over the first layer. Do not use bond breaker tape for this second layer. Before applying the second layer of membrane, coat the entire exposed surface of the first layer of membrane, including the fold, with primer. Center the second layer of

710.03

membrane over the concrete joint, making it straight and wrinkle-free. Ensure this second layer conforms to, and fully adheres to the first layer of membrane.

C. Deck Waterproofing – Preformed.

1. **Construction Procedure.** Prime and place the membrane when the air and concrete temperatures are above 40 °F and the surfaces are dry.

Allow concrete, including grout and repair areas, to cure for at least seven days before applying the primer. Clean the surface using a solvent, and by scraping to remove deleterious material, including oil or grease. Remove sharp protrusions by grinding. Remove old membrane material or asphalt residue using methods approved by the Engineer. Fill potholes and spalls with a diameter greater than $\frac{3}{4}$ inch with a Department-approved epoxy mortar, cement mortar, or concrete and cure as required. Correct elevation differences in the tops of box beams, such as those resulting from camber variation, by wedging with cement mortar or concrete. Sweep and clean surfaces with brooms and compressed air, as required.

After cleaning the deck, apply the primer, using a roller, brush, squeegee, or mechanical means, to the surface of the deck and 2 inches to 3 inches up the vertical face of the curb. Prime only those surfaces that can be covered by membrane the same day. Allow the primer to dry to a non-tacky condition before applying the membrane. Drying time may vary from $\frac{1}{2}$ hour to $1\frac{1}{2}$ hours, depending on the air temperature. Small bubbles on the primer are normal and do not affect the bond

After the primer has cured or dried, apply a Department-approved liquid fillet material to all inside corners. Apply a Department-approved mastic to locations where membrane edges will fall, including the curb face, raised expansion dams, or drain castings. Apply an 8-inch strip of the sheet membrane to the vertical surface of the curb so it comes to a height equal to the planned depth of hot mix asphalt (HMA). Place an 8-inch wide strip of sheet membrane, centered over transverse joints or cracks wider than $\frac{3}{16}$ inch. Do not place the strip at raised steel expansion dams. Firmly press the membrane into the primer and mastic.

Starting at the low, or down-slope side of the deck, place the membrane either by hand or with equipment designed for this purpose. Shingle-lap successive strips of membrane. Place the

membrane, ensuring it is straight, wrinkle free with no bubbles or air spaces under it.

Overlap the edges and ends of the membrane at least 6 inches. At the drain spouts, cut the membrane and turn it down into the spouts or bleeder pipes. Apply a continuous bead of Department-approved mastic along the base of raised expansion dams, butt the sheet membrane up to the dam and press into the mastic.

Immediately after installation of each sheet of membrane, hand roll with a roller that weighs enough to ensure total contact with the deck. Patch torn or cut areas, or narrow overlaps, by placing sections of the membrane over the areas so the patch extends at least 6 inches beyond the defect in all directions. Roll the patch or press firmly in place and apply a Department-approved mastic to the edges.

Remove the separation sheet of plastic or paper as specified by the manufacturer, during the installation of the membrane and before the application of the HMA. Remove stones or other foreign matter found under the membrane after application and patch the area as described in this subsection [710.03.C.1](#).

Do not allow vehicles, except HMA hauling units and the approved rubber-tired paver on the completed waterproofing membrane.

- 2. Placing HMA Over Waterproofing Membrane.** Place the HMA mixture at a temperature from 250 °F to 350 °F according to section [501](#) after placing the membrane. Pave only on a clean and dry membrane surface. Use rubber-tired equipment. Inspect equipment and remove burrs on tires, stones, or sharp projections that could damage the membrane. If the rubber-tired machine skids during warm weather, broadcast fine sand or cement in the tire paths. Avoid excessive use of cement or sand that would prevent adhesion of the HMA.

Preheat paver screeds, but turn burners off during paving to avoid damaging the membrane. Deliver the HMA directly from the hauling unit to the paver. Do not stop the paver with a full hopper. Prevent build up of material in the auger. Keep the level of the HMA in the auger just below the level of the auger shaft. Do not damage the membrane when restarting paving operations. Avoid sudden stops or sharp turns with the compaction rollers.

After rolling the surface, apply a fillet or cove seal using the asphalt-mineral, fiber-solvent caulking material, supplied with the membrane. Apply the seal at the curb line to form a ¾ inch by ¾ inch triangular seal along the edge of the new surface, the full length of the curb.

710.03

D. **Shotcrete.** Pneumatically eject the shotcrete mixture from a mixer or gun through a hose and discharge nozzle, under regulated pressure. Add the liquid latex component at the mixer or gun, or at the nozzle, depending on equipment type and material manufacturer's recommendations.

1. **Test Panels.** Demonstrate to the Engineer, the ability of nozzle operators to correctly apply shotcrete. Use test panels, simulating job conditions, for each gun shooting position (down, horizontal, and overhead) required on the project. Use the same shotcrete material on test panels as proposed for use on the project. Use a panel 2 feet by 2 feet square and at least 3 inch thick, or the same thickness required on the project, whichever is greater. Ensure at least half the panel area has the same reinforcing steel pattern required on the project.

After shotcrete application, keep test panels continuously moist and above 40 °F for 5 days. Remove at least 5 cores from the test panels and test for compressive strength in accordance with ASTM C 39. Cut cores with a diameter of at least 3 inches meeting a length-to-diameter ratio (L/D) of at least 1.0. Adjust core strengths in accordance with ASTM C 42 if the L/D is less than 2.0. Ensure the average compressive strength of the cores is at least 85 percent of the required compressive strength with no individual core having a compressive strength below 75 percent of the required compressive strength.

Take additional cores through the reinforcing steel so the Engineer can evaluate the soundness of the shotcrete behind the steel. The Engineer will examine the cored surfaces and require additional cores or saw cuts if necessary to evaluate soundness and uniformity of deposited material. The Engineer will evaluate the test panels and cores to verify shotcrete surfaces are dense and free from laminations, voids, and sand pockets.

2. **Surface Preparation.** If applying shotcrete to protect waterproofing, perform the work immediately after the completion of waterproofing.

If using shotcrete to repair concrete members, remove unsound concrete from the existing substrate and concrete contaminated by chemicals or oils. Saw cut and repair the edges of the area required for repair, and patch to a depth of at least ½ inch. If using impact tools to remove concrete, provide tools that will not damage sound concrete surrounding and beneath the area being removed.

Use galvanized or epoxy-coated welded wire reinforcing on repairs greater than 2 inches deep. Place the reinforcing at mid-depth of the repair, and at least 1 inch below the surface. Attach the reinforcing to sound concrete with stainless steel anchoring devices spaced in a grid no greater than 18 inches by 18 inches. Use anchors that can support three times the weight of shotcrete allocated to each anchor.

Blast-clean the prepared area and remove traces of dirt, oil, and loose material. Follow with an oil-free air blast to remove abrasive material and dust.

3. **Shotcrete Placement.** Pre-wet the surface with the liquid latex component immediately before placement of shotcrete.

Balance air and material to ensure a steady flow, and to prevent "slugging" of material, plugging, and excess rebound. Apply the mortar using pneumatic equipment that sprays the mix onto the prepared surface at a high enough velocity to produce a compacted dense homogeneous mass, with no sagging or sloughing.

Place each layer of shotcrete in several passes over a section of the work area. Divide large expanses into smaller areas and apply shotcrete to its full thickness before moving to the next area. Avoid laminations during placement.

Keep the nozzle 2 feet to 6 feet from the work. Hold the nozzle as near to perpendicular to the surface as possible, and never more than 45 degrees to the surface.

Remove rebound and overspray that does not fall clear. Do not salvage or recycle rebound and overspray.

Do not apply shotcrete under the following conditions.

- a. High wind preventing proper application;
- b. Surface temperature below 45 °F; or
- c. Rain causing washouts or sloughing of the fresh shotcrete.

4. **Curing.** Cure shotcrete and provide temperature protection in accordance with subsection [706.03.N.3](#).
5. **Testing.** The Engineer may require cutting cores from the completed work for compression testing. If the Engineer orders tests, obtain and test at least three cores in accordance with subsection [710.03.D.1](#).

710.04

710.04. Measurement and Payment.

Pay Item	Pay Unit
Joint Waterproofing	Square Foot
Joint Waterproofing, Railroad.....	Square Foot
Shotcrete	Square Foot, Cubic Foot
Membrane, Preformed Waterproofing.....	Square Foot
Joint Waterproofing, Expansion	Square Foot

A. **Joint Waterproofing.** The Engineer will measure **Joint Waterproofing** by area based on a width of 18 inches and the plan length of joints requiring treatment.

B. **Joint Waterproofing, Expansion.** The Engineer will measure **Joint Waterproofing, Expansion** by area based on an 18 inch width and the plan length of joints requiring treatment. The Engineer will not measure the area of folds or overlapped material for payment. The unit price for **Joint Waterproofing, Expansion** includes the cost of preparing the concrete surfaces and installing the two-layer preformed expansion joint waterproofing membrane system.

C. **Membrane, Preformed Waterproofing.** The Engineer will measure **Membrane, Performed Waterproofing** by the area covered, with no allowance for laps, patches, the 8-inch strips over transverse joints or cracks, or the 8-inch strip applied to the vertical surface of the curb. The Engineer will not deduct the areas of expansion dams or drain spouts.

The unit price for **Membrane, Performed Waterproofing** includes the cost of cleaning the deck; applying the primer, liquid fillet material, and mastic; applying, rolling, and repairing the membrane; and applying the final cove seal mastic along the curb line.

D. **Shotcrete.** The unit price for **Shotcrete** includes the cost of surface preparation; providing, mixing, and applying shotcrete material; test panels, and coring.

E. **Removing HMA Surface.** If required, the Engineer will measure, and the Department will pay for removing HMA surface separately, as **HMA Surface, Rem** in accordance with subsection [501.04](#). The unit price for **HMA Surface, Rem** includes the cost of removing old membrane.

The Engineer will measure, and the Department will pay for scarifying, hand chipping, and patching, if required, separately in accordance with subsection [712.04](#). If the Department cannot determine the amount of scarifying, hand chipping, and patching required before removal of the

710.04

HMA surface, the Department will pay for this work by force account in accordance with subsection [109.05.D](#).

F. **Wedging Along Joints.** The Engineer will measure and the Department will pay for required wedging along joints between prestressed concrete box beams, inspected and accepted by the Department, separately as **Patching Mortar or Conc** in accordance with subsection [712.04](#).

The Engineer will measure, and the Department will pay for the HMA mixture separately in accordance with subsection [501.04](#).

Appendix B.4.2 - Michigan DOT Qualified Waterproofing Membrane Products

QUALIFIED PRODUCTS LIST (QPL)

Spec. # and Material Name	Product Name	Manufacturers or Suppliers
914.06 Epoxy Resin Adhesive & Temporary Seal (Crack Injection)	Crackbond LR321	Adhesives Technology Corp.
	Crackbond SLV302	Adhesives Technology Corp.
	Akabond 817	Axson, Eaton Rapids, MI (formerly Akemi Corp.)
	Akabond 818	Axson, Eaton Rapids, MI (formerly Akemi Corp.)
	Akabond 819	Axson, Eaton Rapids, MI (formerly Akemi Corp.)
	MasterInject 1380	BASF Construction Chemical, Shakopee, MN
	MBT P&R Concsive 1360	BASF Construction Chemical, Shakopee, MN
	BHS-1617	Blackhawk Sales Co, Inc., Rock Island, IL
	BHS-1618	Blackhawk Sales Co, Inc., Rock Island, IL
	BHS-1619	Blackhawk Sales Co, Inc., Rock Island, IL
	Arndite 8560	Ciba Corporation, East Lansing, MI
	EP-SLV	E-Chem, LLC
	True Grip 150	J. Dedoes, Inc., Milford, MI
	NIP124LV	Epoxy Unlimited, Harrison Twp, MI
	CI 060	Hilti Inc., Columbus, OH
Dynapoxy EP-450	Pecora Corporation	
E Bond 550	Ridgemoor Supply, Kentwood, MI	
Sikadur 35, Hi-Mod LV	Sika Corporation, Lyndhurst, NJ	
Sikadur 52	Sika Corporation, Lyndhurst, NJ	
Pro Poxy 50 Super LV	Unitex, Kansas City, MO	
914.07A Transverse Pavement Joint 1. Dowel Bar Coating (Epoxy) 2. Bond Release	See Reinforcement Bar Coating, QPL 905.03C	
	Bond Release Agent - Tectyl 506 BCG Protec 6116 DS MA	Daubert Chemical Bradley Coatings Group
914.08 Transverse Pavement Joint, <u>Deformed</u> Dowel Bar Coating	See Reinforcement Bar Coating, QPL 905.03C	
914.09 Straight & Bent Tie Bars for Longitudinal Pavement Joints (Lane Ties), Coating	See Reinforcement Bar Coating, QPL 905.03C	
914.11 Preformed Waterproofing Membrane NOTE: Not to be used on Treated Wood Materials.	Carlisle CCW 711-Highway and Bridge Membrane	Carlisle Coatings and Waterproofing
	Geotac Waterproofing Membrane	Crafco Inc.
	Geotac Polyester HS	Crafco Inc.
	Petrotac 4591	Propex Operating Company
	Protecto Wrap M400 AR	Protecto Wrap Co.
	Sealtight Mel-Dek	W.R. Meadows, Inc.

Appendix B.4.3 - Nebraska DOT Special Provisions for Cold Liquid-Applied Membrane

5.G39 – Cold Liquid-Applied Membrane

COLD LIQUID-APPLIED MEMBRANE (G-39-1016)

000.01 - - Description of Work

1. This work shall consist of preparation of the deck or approach surfaces, providing and installing a seamless spray elastomer waterproofing membrane to suitable concrete or miscellaneous metal surfaces. The tack coat and asphaltic surface course are not part of this item.

000.02 - - Material Requirements

1. The Cold Liquid-Applied Membrane (CLAM) shall be a spray applied, 100% solids, fast cure, and high-build polymer system consisting of the following components:
 - a. A two component polymer primer shall be applied at 130-200 ft²/gallon, or at the rate specified by the manufacturer.
 - (1) The primer materials shall meet the requirements shown in Table 2.
 - (2) The primer shall be provided by the same manufacturer as the base membrane.
 - b. The base membrane shall be applied to the primer at a minimum thickness of 80 mils or at the minimum thickness required to pass the crack bridging test, whichever is thicker.
 - (1) The base membrane materials shall meet the requirements shown in Table 3.
 - c. The Bridge Deck Top Coat shall be applied to the base membrane at 30 - 40 mils and an aggregate layer shall be broadcast into it before it hardens.
 - (1) The Bridge Deck Top Coat shall be a 100% solids, two component, rapid curing elastomer that is compatible with the base membrane.
 - (2) The Bridge Deck Top Coat materials shall meet the requirements shown in Table 4.
 - (3) The aggregate for the top coat shall be 1/4 Inch Clean Chips of Crushed Rock of 100% Ledge Rock Material and shall comply with Section 1033 of the Specifications amended as per Table 1.
 - (4) The top coat aggregate shall be broadcast into the top 40 mils of waterproofing membrane at a rate of 0.5 to 1.0 pound per square foot or approved equal subject to approval by the Engineer.

- d. Products on the Approved Products List under “Wick Drains for Asphalt Overlays on Bridges” may be used without additional approval. Other products meeting the requirements of Table 5 may be submitted to the Engineer for approval.
2. Base Membrane, Bridge Deck Top Coat and aggregate layer shall be capable of accepting emergency and temporary vehicular traffic at highway speeds greater than 65 mph one hour after application.
- a. A non-skid aggregate surface shall be retained without significant aggregate loss throughout the duration of traffic exposure.
 - b. Membrane system shall not be exposed to traffic for more than 7 days or as allowed by the product manufacturer.
3. Material certifications must be submitted and approved 10 days prior to construction. Material Submittals shall include the following:
- a. Manufacturer shall provide independent laboratory test results certifying each component’s conformance to the physical property requirements listed in Tables 2, 3 and 4. All testing shall be current (conducted within the past three (3) years).
 - b. The manufacturer’s material safety data sheets (MSDS) for each of the components. All primers and membranes shall be from the same manufacturer.
 - c. Two sample coupons (4”x4”) that are representative of the finished membrane surface, texture, and color.

**Table 1.
Top Coat Aggregate Gradation**

size	percent Passing
1/4 inch	98 - 100
#4	75 - 100
#8	2 - 40
#16	1 - 10
#200	0 - 0.3

**Table 2.
Material Properties of Primer**

Properties	Test Method	Value
Minimum Gel Time (minutes)		5
Maximum Tack Free Time at 77 °F (hours)		2.5
Mixing Ratio		Per Manufacturer
Minimum Adhesion to Concrete (psi)	ASTM D 4541	150

Table 3.
Material Properties of Base Coat

Properties	Test Method	Value
Solids Content (%)		100
Minimum Shore Hardness Type D	ASTM D2240	50
Minimum Elongation (%)	ASTM D638	250
Minimum Tensile strength (psi)	ASTM D638	2000
Tear Strength, pli, Die C	ASTM D624	390
Maximum Taber Abrasion (mg loss)	ASTM D4060	250
Moisture Vapor Transmission (perms)	ASTM E96 Procedure B	0.90
Maximum Gel Time (seconds)		10
Tack Free (seconds)		30
Open to Traffic (hours)		N/A
Crack Bridging Test opening (inches)	ASTM C1305 for minimum of 80 mils at -15 °F for 40 cycles with 1/8 inch opening	pass

Table 4.
Material Properties of Top Coat

Physical Property	Test Method	Value
Solids Content (%)		100
Minimum Gel Time (seconds)		30
Minimum Tack Free Time (minutes)		5
Minimum Cure Time to Open to Traffic (hours)		1
Minimum Shore Hardness Type D	ASTM D2240	40
Minimum Tensile strength (psi)	ASTM D 638	2000
Tear Strength Die C (pli)	ASTM D 638	350
Minimum Elongation at break (%)	ASTM D 638	150
Crack Bridging Test	ASTM C1305 for minimum of 80 mils Base Coat + 40 mils Top Coat with Aggregate at -15 °F for 40 cycles with 1/8 inch opening	pass

**Table 5.
 Physical Requirements of Wick Drain**

Fabric Properties	Value	Test Method
Material	Polypropylene	
Minimum Grab Tensile Strength (lb)	130	ASTM D-4632
Minimum Puncture Strength (lb)	41	ASTM D-4833
Minimum Trapezoidal Tear (lb)	60	ASTM D-4533
Minimum Elongation (%)	50	ASTM D-4632
EOS (AOS) (sieve size)	70	ASTM D-4751
Minimum Permittivity (1/sec)	0.8	ASTM D-4491
Minimum Flow Rate (gpm/sqft)	60	ASTM D-4491
Minimum UV Stability (%)	70	ASTM D-4355
Core Properties		
Material	Polypropylene	
Minimum Tensile Strength (lb)	225	ASTM D-4595
Product Properties		
Minimum Discharge Capacity (gpm)	1.6	ASTM D-4716
Roll width (in)	3 to 4.5	
Maximum total thickness (in)	0.5	

000.03 - - Construction Methods

1. Construction methods and procedures must be submitted to the Engineer for approval at least 10 days prior to construction. Construction method submittal shall include the following:
 - a. Substrate preparation and repair details.
 - b. The manufacturer's current installation and testing procedure document. This document shall conform in its entirety with all the requirements specified herein.
 - c. Service record showing that the membrane applicator has a satisfactory record of not less than 3 years, prior to the date of submission, for similar applications with names of specific structures and owner contact information.
 - d. Service record showing that the membrane manufacturer has a satisfactory record of not less than 5 years, prior to the date of submission, for similar applications with names of specific structures and owner contact information.
 - e. Scheduling and phasing of the installation.
2. Storage
 - a. All materials shall be shipped and stored in a dry shaded area between 35°F to 90°F and according to the manufacturer's recommendations.

3. Preparation of the Surface to be covered by Waterproof Membrane

- a. Concrete substrate shall be clean and sound. Unsound concrete shall be removed and replaced with approved repair concrete.
 - (1) Newly placed concrete shall be broom finished. No belting, scoring, tining or other texturing shall be used.
 - (2) Portland cement concrete to be covered by Waterproof Membrane shall cure for a minimum of 12 days before applying the waterproof membrane.
- b. The Engineer shall be contacted for guidance if ponding of water is observed on the concrete bridge deck before membrane is placed.
- c. If deck drain pipes are present the tops of the pipes shall be level with the surface of the deck or below the surface of concrete deck by not more than 1/4-inch.
- d. Concrete surfaces to be covered by membrane shall be prepared to SSPC-SP13/NACE No. 6.
- e. Metal surfaces to be covered by membrane shall be prepared in accordance with SSPC-SP10 Near White Blast.
- f. Surfaces that are not to be covered with membrane shall be protected to prevent defacement by membrane system. Should defacement occur the Contractor shall clean surfaces on the structure as directed by the Engineer at no cost to the Department.

4. Weather and Moisture Conditions

- a. The membrane system shall not be applied in wet weather or at ambient temperatures below 35 °F without approval by the Engineer and the Product manufacturer. The primer or adhesive shall only be applied on clean and dry surfaces when the temperature of the substrate exceeds the dew point by at least 5 °F (3° C). Special attention shall be given to assure that there is no moisture present at the interface between the deck and bridge curb.
 - (1) The Contractor shall verify that surfaces to which membrane system will be applied are sufficiently dry by one of the two following methods.
 - (a) No condensation shall be found by taping an 18 inch by 18 inch plastic sheet tightly to the surface of the concrete per ASTM D4263. The plastic sheet test shall be performed only when surface temperatures and ambient conditions are within the established parameters for application of the overlay system. In the event of rain, the concrete shall be allowed to air dry for a minimum of 24 hours before performing the plastic sheet test. This test shall be performed by the Contractor and observed by the Engineer. The Department will allow a 4 hour test duration instead of the 16 hours specified in ASTM D4263.

(b) Substrate moisture content shall be 5.0% or less when tested concrete moisture content with a non-destructive concrete moisture meter. This method shall be accepted only if accurate calibration can be demonstrated to the Engineer.

(2) The Contractor shall supply a digital weather instrument that can measure both ambient temperature and dew point, and an infrared surface temperature measuring instrument.

5. Membrane System Placement

- a. Installation of Membrane system shall not begin until all materials and equipment to complete the work are on the job site. All equipment shall be maintained in good working order and reserve equipment shall be available as required.
- b. Manufacturer's representative shall be on-site throughout the installation process and shall perform and record relevant quality control readings.
- c. The primer shall be applied on prepared surfaces at the rate specified by the manufacturer.
- d. Primer shall be tack free before placement of the membrane. Primer shall be reapplied if set more than 24 hours.
- e. Spray waterproofing membrane over primed surfaces at a minimum thickness of 80 mils (20 ft² per gallon) or the minimum thickness required to pass the ASTM C 1305 Crack Bridging Test. Spray additional base coats as required to achieve the specified thickness.
 - (1) The lips of drain openings and edges of open joints, deck slab, and other openings at deck level shall be completely sealed by extending the full waterproofing course over the lip or edge.
 - (2) Edge of membrane shall extend up the face of curbs to 1/2 inch below the height of the overlay surface.
- f. Spray top coat membrane over base membrane at a thickness of 30-40 mils and immediately broadcast aggregate at 0.33-0.50 lbs. per ft² to achieve a minimum coverage rate of 95%.
- g. Wick drains shall be placed on a thin layer of tacky mastic on top of Membrane. Wick drains shall be placed at the face of low-side curbs extending longitudinally to terminate at deck drains or ends of closed bridge rail or as shown in the plans. Wick drains are not required on bridges with open rails.

6. Asphalt Overlay

- a. Tack coat shall be applied to the surface of the membrane top coat to aid in bonding the asphaltic concrete to the membrane. The rate of application shall not be less than 0.1 gal./sy. Application rate will be verified during construction.
 - (1) Surfaces to which tack coat is applied shall be clean and dry.
 - (2) The surface shall be paved with asphalt the same day the tack coat is placed.
 - (3) When multiple lifts of asphalt are placed, tack coat shall be applied at the specified rate to each underlying lift.
- b. A minimum of 3 inches compacted overlay thickness is required unless otherwise shown in plans.
- c. The use of a pickup machine and the dumping of asphaltic concrete directly on the membrane are not allowed unless a placement program is submitted for approval by the Engineer.
- d. Rollers shall be operated in static mode unless permitted by the Engineer.
- e. A vibratory plate compactor shall be on site and used in areas that cannot be roller-compacted such as near the face of bridge rails.

7. Quality Control

- a. The Contractor shall use magnetic, ultrasonic, or destructive testing to assure proper application, including identifying unbonded areas. The Contractor shall include with other submittals the method, minimum number, and randomness of the locations for testing. Any destructive testing areas shall be repaired by re-spraying or filling with the production liquid membrane material.
- b. All areas of unbonded membrane shall be removed and replaced, or repaired with means acceptable to the Engineer at the Contractor's expense prior to the placement of the asphalt overlay.
- c. After membrane system is inspected and accepted, the tack coat and Hot Mix overlay can be placed as shown in the plans. The hot mix contractor shall take care and make placement operations as in accordance by the membrane manufacturer and any other requirements of the Certified Representative.
- d. All details for the installation, plan, materials, schedules, certifications, and construction of the membrane and Asphalt overlay shall be submitted, reviewed and approved prior to installation. A pre-paving meeting shall be scheduled by the Contractor with the Project Manager and NDOR Staff, and all subcontractors involved in performing this work, at least 72 hours prior to construction.

000.04 - - Method of Measurement

1. The unit of payment for the Cold Liquid-Applied Membrane is the Square Foot.
 - a. The area receiving the membrane system will not be measured directly, but will be plan dimension of the surface receiving the treatment.

000.05 - - Basis of Payment

- | 1. | Pay Item | Pay Unit |
|----|--|------------------|
| | Cold Liquid-Applied Membrane Waterproofing | Square Foot (SF) |
2. Payment is full compensation for all work prescribed in this Section.

Appendix B.5 - Draft Specifications for Hot Mixed Asphalt Overlay without Waterproofing Membrane

SECTION XXXX. BRIDGE DECK ASPHALT OVERLAY WITHOUT WATERPROOF MEMBRANE USING STANDARD PROCEDURE**1.01 Description**

These specifications describe requirements for an asphalt overlay without waterproofing membrane on an existing reinforced concrete deck. Apply Section 2303 of the Standard Specifications unless otherwise directed in these specifications.

1.02 Materials

4. Hot Mixed Asphalt (HMA) Overlay

Apply Section 2303 of Iowa DOT Standard Specifications for material requirements.

1.03 Construction

5. Surface Preparation

1. Remove existing deck overlay and clean deck surface in accordance with Section 2413. of the Iowa DOT Standard Specifications.

2. Repair areas of Class A deck repair as defined in Article 2413.01 of the Standard Specifications and designated by the Engineer.

3. Repair areas of Class B deck repair as defined in Article 2413.01 of the Standard Specifications and designated by the Engineer.

6. HMA Overlay:

1. Apply Section 2303 of the Standard Specifications for construction of HMA overlay.

2. Apply tack coat prior to placement of HMA overlay.

1.04 Method of Measurement

Hot Mix Asphalt Overlay will be measured according to Article 2303.04 of the Standard Specifications.

1.05 Basis of Payment

Hot Mix Asphalt Overlay will be paid for according to Article 2303.05 of the Standard Specifications.

Appendix B.6 - Kentucky DOT Special Note for Asphalt Waterproofing Mix For Bridge-Deck Overlays

**SPECIAL NOTE FOR ASPHALT WATERPROOFING MIX
FOR BRIDGE-DECK OVERLAYS AND ADJACENT APPROACHES**

1. DESCRIPTION. Asphalt Waterproofing Mix (AWM) is a highly elastomeric, polymer-modified, impermeable asphalt mixture that is designed to be a one-step, waterproof, wearing course system for bridge-deck overlays and the adjacent approaches. Place AWM at a minimum thickness of 1.50 in. directly on the prepared surface using a conventional paver and rollers. Apply this material according to the lines, grades, and typical cross-sections in the plans or as established by the Engineer.

Unless otherwise noted, Section references herein are to the Department's 2012 Standard Specifications for Road and Bridge Construction. Conform to all requirements for CL3 ASPH SURF 0.38A unless specifically modified herein.

2. MATERIALS AND PERSONNEL.

2.1 Aggregate. Provide polish-resistant coarse and fine aggregate conforming to Subsection 403.03.03 for a Type A mixture. Do not use mineral aggregates that are inherently porous, such as blast-furnace slag, expanded shale, porous limestone, and lightweight aggregates, in this mixture.

2.2 AWM Binder. Provide a performance-graded (PG) binder which conforms to AASHTO M 320 with a high temperature of 76 °C or higher and a low temperature of -28 °C or lower. In addition, ensure that the AWM binder conforms to the following criteria:

<u>Test</u>	<u>Criteria</u>
Multiple Stress Creep Recovery (AASHTO TP70) (64 °C, 3.2 kPa)	75%

2.3 Edge Sealant. Provide a solvent-free material for edge sealant as recommended by the producer of the thermoplastic polymer modifier utilized in the AWM. Ensure the material is a highly thixotropic edge sealant that dries to a soft consistency and will not dry out, crack, or split under vibration or slight movement of opposing surfaces.

2.4 Adhesive Tack Coat. Provide a solvent-free material for adhesive tack coat as recommended by the producer of the thermoplastic polymer modifier utilized in the AWM.

2.5 Joint Sealant. Provide a solvent-free material for joint sealant as recommended by the AWM material supplier. Ensure the material is capable of bonding to metal, wood, masonry, plastics, and elastomers without the use of a primer.

2.6 AWM Representative. Ensure a technical representative from the material supplier for the AWM is present during the initial construction activities (trial demonstration and set-up period) and available upon the request of the Engineer.

3. CONSTRUCTION.

3.1 Preparation of Mixture. Ensure the AWM contains no reclaimed materials. Submit the AWM design and component material samples to the Division of Materials according to Subsection 402.03.

3.2 Job-Mix Formula (JMF). Contrary to Subsection 402.03, formulate and submit a JMF conforming to the material suppliers recommended gradation limits and the following total binder content.

% Total binder (including PG binder and thermoplastic polymer)	7.25-9.25	± 0.5
--	-----------	-------

3.3 Mix Design Criteria. Contrary to Subsection 403.03, using a compaction effort of $N_{des} = 50$ gyrations and a compaction temperature recommended by the material supplier, perform and submit a laboratory mix design conforming to the following mixture specifications.

<u>Test</u>	<u>Criteria</u>
% Air Voids (AV) (AASHTO R 35)	1.0 ± 1.0
% Voids-in-Mineral Aggregate (VMA) (AASHTO R 35)	16.0 (min)
Permeability (ASTM D 5084)	<1 x 10 ⁻⁹ m/s
Flexural Beam Fatigue (ASTM D7460) (750 microstrains, 10Hz, 1.5 ± 0.5 %AV, 15°C)	250,000 cycles (min) (average of two samples)
APA @ 8,000 Loading Cycles (AASHTO TP 63)	<3 mm

The Department will not require AWM blends previously documented as satisfying the flexural beam fatigue specification to be tested again for flexural beam fatigue. Also, the Department will not require flexural beam fatigue testing for projects with a total AWM quantity of less than 1000 tons. Mix design criteria testing which cannot be performed by the department must be performed by a third party laboratory.

3.4 Surface Preparation. Prior to the project, review the existing bridge deck(s) and approach pavement with a technical representative from the material supplier for the AWM and Department personnel to develop a strategy for repairing distressed areas.

Prior to the placement of the AWM over the PCC bridge deck(s) and approach pavement and as directed by the Engineer, repair any moderately or highly “D-cracked” areas, high-severity “punch-outs,” “blow-ups,” and other severe distresses with a doweled, full-depth patch. Ensure the patching material satisfies the applicable requirements of Section 502.

Prior to the placement of the AWM over asphalt pavement and as directed by the Engineer, fill large surface deformities, greater than 3 in. deep and 4 ft in diameter, with an approved asphalt mixture.

Immediately prior to placing the AWM, thoroughly clean the surface of all vegetation, loose materials, dirt, mud, and objectionable materials. Ensure the surface is dry. During placement of the AWM, fill smaller pavement deformities in the underlying bridge deck(s) and approach pavement with the AWM.

3.5 Application of Edge Sealant. Apply edge sealant, at 4 to 6 in. wide and approximately 0.03 in. thick, before and after AWM application in accordance with the guidelines from the material supplier for the AWM. Apply the sealant to all perimeter surfaces adjacent to the AWM, such as curbs, parapet walls, headers, drains, scuppers, and joints, in order to reduce moisture infiltration into the AWM. Also apply edge sealant to all longitudinal or transverse joints in the AWM that have cooled below 150 °F. When practical, apply the edge sealant the day before or as early as possible on the day of paving to maximize drying time.

3.6 Application of Adhesive Tack Coat. Contrary to Subsection 406.03, cold-apply an adhesive tack coat to the existing pavement at a rate to achieve an undiluted residue of 0.10 to 0.15 gal/yd². For milled surfaces, apply the tack coat at a rate to achieve an undiluted residue of 0.15 gal/yd². For smaller projects as defined by the Engineer, cold-apply the tack coat by hand with a brush, roller, or hand-wand sprayer. Ensure the surface is free of all dust, dirt, oil, grease, and other contaminants. Allow the adhesive tack coat to cure for a period of at least 40 min, or until the tack coat is dry, depending on local conditions.

3.7 Application of Joint Sealant. For continuous paving operations over existing bridge/pavement joints, saw-cut a construction joint, 1.0 to 1.5 in. wide, in the AWM and fill the joint with joint sealant as directed by the technical representative from the material supplier for the AWM or by the Engineer. Ensure the surface is free of all dust, dirt, oil, grease, and other contaminants. Do not apply the sealant on a wet surface. Allow the joint sealant to cure for at least 12 h before opening to traffic.

3.8 Production, Transport, and Placement of AWM

Ensure the existing surface temperature is a minimum of 40 °F and rising at the time of AWM placement.

Contrary to Subsection 401.03, produce and place AWM at the temperature recommended by the material supplier.

3.9 Compaction of AWM.

3.9.1 Rollers. Contrary to Subsection 403.03, compact the AWM only with steel, double-drum drive rollers in the static mode. Provide breakdown rollers with a static weight of approximately eight tons. Provide finish rollers with a static weight of four to eight tons and a maximum drum width of 60 in. Also provide a small roller or vibratory plate to compact smaller areas such as headers, scuppers, expansion joints, etc. that cannot accommodate a full-size roller.

3.9.2 Opening to Traffic. Open lanes to traffic when the AWM pavement reaches 120 °F or a minimum of 1 h after compaction is completed.

3.10 Trial Demonstration(s). At least two days prior to beginning mainline paving, demonstrate that satisfactory production and placement of AWM is possible. Furnish at least 50 tons for the trial demonstration. The Engineer will determine the location, outside of the driving lanes, and exact quantity of the trial placement. Perform a minimum of one volumetric analysis (two gyratory specimens and two G_{mm} tests), one total binder content determination, and one gradation determination. Document that the AWM satisfies the applicable requirements of Sections 3.2 and 3.3 of this note for total binder content, gradation, AV, and VMA prior to beginning mainline paving.

Use the paver and rollers to be used on the project to construct the trial placement. Obtain and test a minimum of four roadway cores from the trial placement according to KM 64-442. Ensure the density of each core is within the range of 96.0 ± 2.0 percent of the theoretical maximum density prior to beginning mainline paving.

Furnish additional 50-ton production lots until achieving mixture properties that satisfy the requirements above. Construct additional trial sections until establishing a rolling pattern that provides the density specified above.

Also furnish an additional 50-ton production lot and construct a new trial placement whenever a change in the mix design, compaction method, or compaction equipment occurs. When directed by the Engineer, remove and replace trial sections with unacceptable results.

3.11 Acceptance Sampling and Testing. Contrary to Subsection 402.03.02, the Department will accept AWM as follows:

3.11.1 Definitions for Sublot, Lot, and Minimum Level of Testing. Contrary to Subsection 402.03.02, for projects with a total AWM quantity of less than 4000 tons, the Department will define a sublot as 250 tons and a lot as 1000 tons. For these projects, the Department will define the setup period as the first 250 tons of production. For projects with a total AWM quantity of 4000 tons or more, the Department will define a sublot, a lot, and the setup period according to

Subsection 402.03.02. In either case, perform a minimum of one complete set of acceptance tests, as defined by this note, each day that any AWM is produced.

3.11.2 Total Binder Content and Gradation. Perform one evaluation per subplot according to Subsection 402.03.02. By the end of the setup period, establish a JMF conforming to the total binder content and gradation limits from Section 3.2 of this note. The Department will allow the established JMF to vary within the production tolerances from Section 3.2 of this note provided the percent passing each sieve remains within the gradation limits and the total binder content remains within the specified range.

3.11.3 AV. Prepare and analyze one set of two gyratory specimens per subplot according to Subsection 402.03.02. By the end of the setup period, test the AWM to document that the average AV value of each set of specimens conforms to the limits from Section 3.3 of this note.

3.11.4 VMA. Prepare and analyze one set of two gyratory specimens per subplot according to Subsection 402.03.02. By the end of the setup period, test the AWM to document that the average VMA value of each set of specimens conforms to a minimum of 15.5 percent.

3.11.5 Density. For each subplot of production after the setup period, randomly select locations for four cores from the bridge approach areas, not the bridge deck itself, in order to preserve the integrity of the AWM over the bridge deck. Obtain and furnish the cores to the Engineer according to Subsection 402.03.02. The Department will test the cores to ensure the following criteria are satisfied:

- the density of each core is between 94.0 and 98.0 percent of the G_{mm} value for that subplot; and
- the average density of the four cores is a minimum of 96.0 percent of the G_{mm} value for that subplot.

3.11.6 Unsatisfactory Work Based on Laboratory Data. When the total binder content, gradation, AV, VMA, or density value from any test after the setup period fails to satisfy the applicable requirements of this note, cease all shipments to the project. Adjust procedures or mixture composition until all properties satisfy the applicable requirements of this note. Document acceptable materials and work before restarting operations.

3.12 Verification Sampling and Testing. Contrary to Subsection 402.03.03, the Department will verify AWM as follows. Using the definition for a lot from Section 3.11.1 of this note, the Department will perform a minimum of one verification test for total binder content, gradation, AV, and VMA for each lot according to Subsection 402.03.03. Provided the differences between the contractor's acceptance test and the Department's verification test are within the tolerances given in Subsection 402.03.03, the Department will accept the AWM for that lot.

When the differences between the contractor's acceptance test and the Department's verification test are not within the tolerances given in Subsection 402.03.03, cease all shipments to the project. Adjust procedures or mixture composition until the differences are within the tolerances given in Subsection 402.03.03. Document compliance with these tolerances before restarting operations.

4. MEASUREMENT.

4.1 Trial Demonstrations. The Department will measure up to 100 tons of AWM used in the trial demonstration. The Department will not measure quantities exceeding 100 tons for payment and will consider them incidental to the AWM.

4.2 AWM. The Department will measure the AWM in tons. The Department will not measure the surface preparation, edge sealant, adhesive tack coat, or joint sealant for payment and will consider them incidental to the AWM. The Department will not measure saw-cutting joints for payment and will consider that operation incidental to the AWM.

5. PAYMENT.

5.1 Trial Demonstrations. The Department will pay for the measured quantities at the Contract unit bid price for the AWM.

5.2 AWM. The Department will consider the unit bid price per ton to include all labor, materials, and equipment necessary to complete the work. The Department will make payment for the completed and accepted quantities according to the following:

<u>Code</u>	<u>Pay Item</u>	<u>Pay Unit</u>
21138ED	Asphalt Waterproofing Mix	Ton