

A d d e n d u m

Iowa Department of Transportation
Office of Contracts

Date of Letting: February 21, 2017
Date of Addendum: February 16, 2017

B.O.	Proposal ID	Proposal Work Type	County	Project Number	Addendum
008	57-0307-173	BRIDGE NEW -PPCB	LINN	NHSX-030-7(173)--3H-57	21FEB008A01

Make the following change to NHSX-030-7(173)--3H-57 plan:

Replace plan sheet 9 with the attached plan sheet.

“velour” in the thin brick note, replace with "wire cut or velour".

PIER AESTHETICS NOTES

THE PIER COLUMNS INCLUDE CONCRETE RUSTICATION. NO PRODUCTION CONCRETE WORK THAT INCLUDES RUSTICATION SHALL PROCEED UNTIL APPROVAL OF A MOCKUP PANEL BY THE ENGINEER. SEE CONCRETE RUSTICATION NOTES ON THIS DESIGN SHEET. SEE MOCKUP DETAILS AND NOTES ON DESIGN SHEET 12.

THE PIER CAP INCLUDES INTEGRAL THIN VENEER BRICK. SEE THIN VENEER BRICK NOTES ON THIS DESIGN SHEET. THE MOCKUP PANEL MUST BE REVIEWED AND APPROVED BY THE ENGINEER BEFORE BEGINNING PRODUCTION CONCRETE WORK THAT INCLUDES THIN BRICK.

CONCRETE RUSTICATION NOTES

THE INCLUSION OF RUSTICATIONS AROUND THE ENTIRE PERIMETER OF ROUND COLUMNS REQUIRES THAT RUSTICATION STRIPS BE FASTENED TO THE FORMS IN A MANNER THAT WILL PERMIT THEM TO REMAIN IN PLACE WHEN THE MAIN COLUMN FORMS ARE REMOVED. DO NOT ATTEMPT TO REMOVE COLUMN FORMS WITH RUSTICATION STRIPS STILL ATTACHED TO THE FORMS. LEAVE INSERTS IN PLACE UNTIL THEY CAN BE REMOVED WITHOUT DAMAGE TO THE SURROUNDING CONCRETE. RUSTICATION INSERTS SHALL BE ATTACHED TO FORMS SUCH THAT THEY WILL NOT ALLOW LEAKAGE OF CONCRETE BETWEEN THE FORM AND THE INSERT. IF NECESSARY, SEAL THE STRIPS TO THE FACE OF THE FORM WITH CAULK.

NO PLAIN LUMBER OR PLAIN UNFACED PLYWOOD MAY BE USED TO CREATE RUSTICATIONS. STRIPS USED AS INSERTS WITHIN CONCRETE FORMS TO CREATE THE RUSTICATION FEATURES MAY BE MADE OF FACED PLYWOOD, STEEL, NYLON, PLASTIC OR OTHER NONPOROUS MATERIAL CAPABLE OF WITHSTANDING ANTICIPATED CONCRETE POUR PRESSURES WITHOUT PHYSICAL DEFECTS. ALL INSERTS SHALL BE FREE OF WARP, TWIST, CHECKS OR CRACKS.

THE INSERTS SHALL BE DESIGNED TO FORM SURFACES AND FEATURES CONFORMING TO THE DESIGN INTENT INCLUDING THE SHAPE, LINES, DEPTHS AND DIMENSIONS SHOWN IN THE PLANS. CREATE INDIVIDUAL INSERTS WITH NO SPLICE JOINTS IN THEIR LENGTH.

DURING LOADING OF FORMS WITH CONCRETE, TAKE EXTRA CARE TO ENSURE PROPER CONSOLIDATION OF CONCRETE AROUND ALL RUSTICATION INSERTS TO PRESERVE THE SHAPE, LINE AND DEPTH OF ALL INTENDED FEATURES IN THE FINAL CONCRETE SURFACE. FOLLOWING REMOVAL OF FORMS AND STRIPS, REPAIR ALL DEFECTS TO ACHIEVE THE RUSTICATION FEATURES AS SPECIFIED IN THE PLANS. PATCH VOIDS, HONEYCOMB AREAS, ETC., IN ACCORDANCE WITH THE STANDARD SPECIFICATIONS. ADD WHITE CEMENT TO THE PATCHING MORTAR TO LIGHTEN IT IN ORDER TO MATCH OR BE SLIGHTLY LIGHTER THAN SURROUNDING CONCRETE WHEN DRY. COMPLETED SURFACE SHALL BE FREE FROM BLEMISHES, SURFACE VOIDS AND CONSPICUOUS FORM MARKS TO THE SATISFACTION OF THE ENGINEER. THE CONTRACTOR SHALL CORRECT ANY SURFACE DEFECTS TO THE SATISFACTION OF THE ENGINEER AT NO ADDITIONAL COST TO THE PROJECT.

ALL COSTS ASSOCIATED WITH CONCRETE RUSTICATION ARE TO BE INCLUDED IN THE BID ITEM "HIGH PERFORMANCE STRUCTURAL CONCRETE".

THIN VENEER BRICK NOTES

THIS WORK CONSISTS OF CREATING THIN VENEER BRICK FINISHES ON ALL DESIGNATED CONCRETE SURFACES OF THE PIER AND TRAFFIC BARRIERS AS SHOWN IN THIS PLAN. SEE "SPECIAL PROVISIONS FOR INTEGRAL THIN VENEER BRICK FOR STRUCTURAL CONCRETE" FOR MORE INFORMATION. THE MOCKUP PANEL MUST BE REVIEWED AND APPROVED BY THE ENGINEER BEFORE BEGINNING PRODUCTION CONCRETE WORK THAT INCLUDES THIN BRICK.

THE SYSTEM USED TO CREATE THE INTEGRAL THIN BRICK AS SHOWN IN THE PLAN DETAILS SHALL PRODUCE MODULAR SIZE BRICKS IN RUNNING BOND AND SOLDIER COURSE BRICK PATTERNS AS INDICATED IN THE DRAWINGS. BRICK COLOR SHALL BE A MIXTURE OF RED-ORANGE TONES USING UP TO TWO DIFFERENT COLOR LOTS CHOSEN FROM THE MANUFACTURER'S AVAILABLE COLORS. BRICK TEXTURE SHALL BE WIRE CUT OR VELOUR. SUBMIT THIN BRICK SAMPLES FOR COLOR SELECTION AND FOR APPROVAL IN ACCORDANCE WITH THE SPECIAL PROVISIONS PRIOR TO ORDERING MATERIALS.

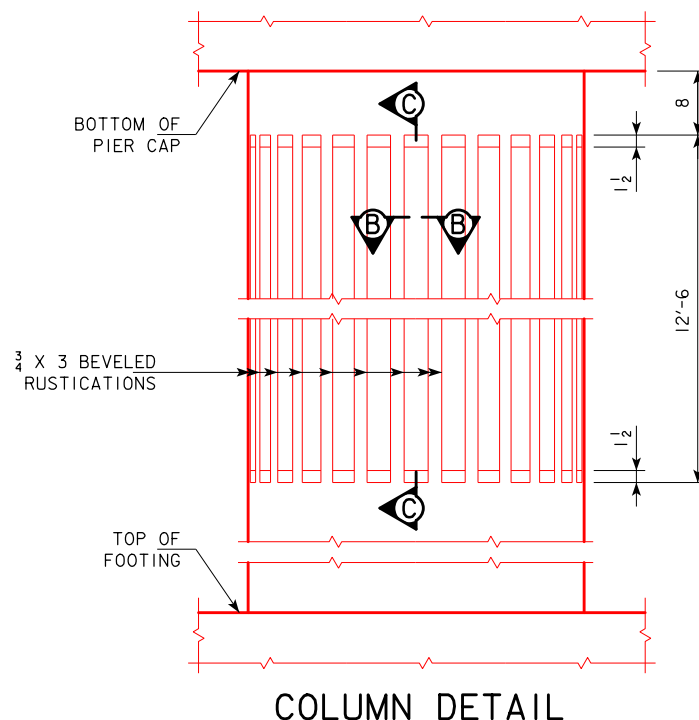

COLUMN DETAIL

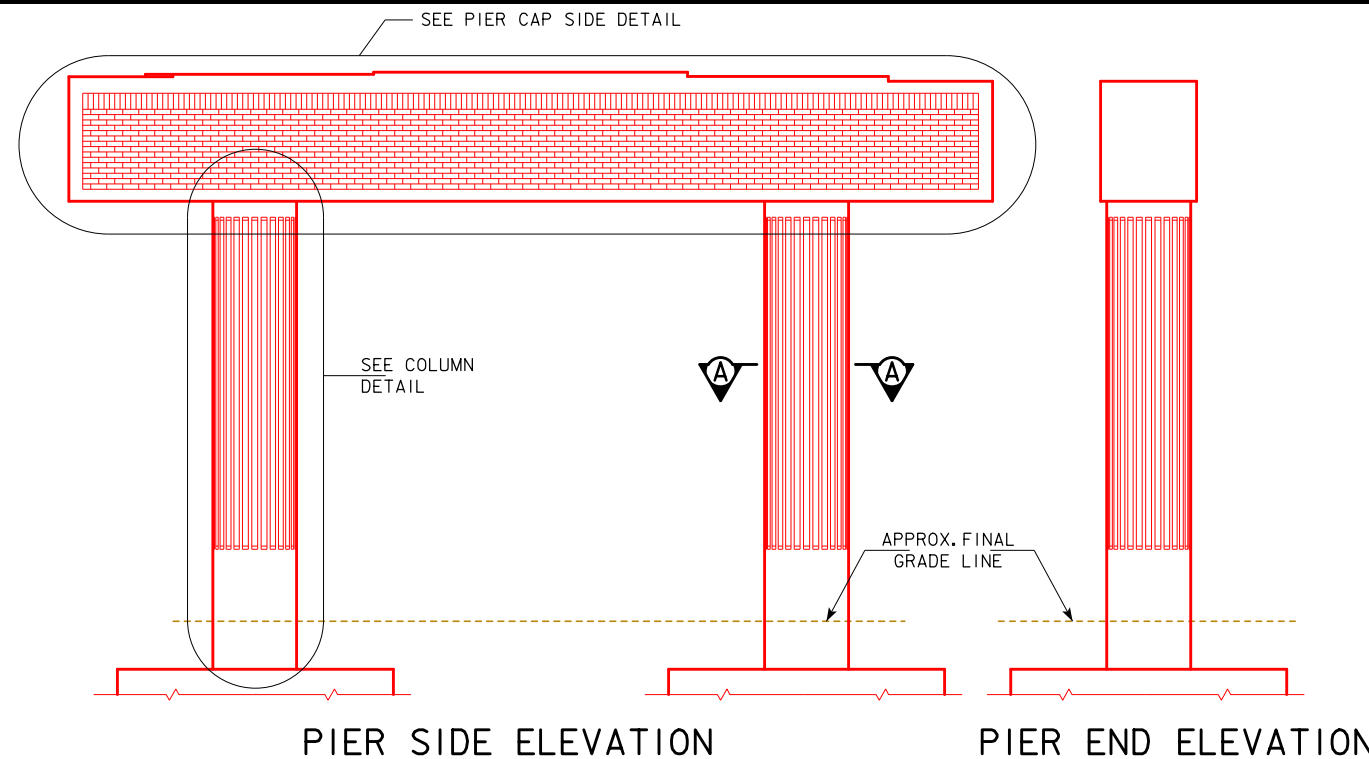

PIER SIDE ELEVATION

PIER END ELEVATION

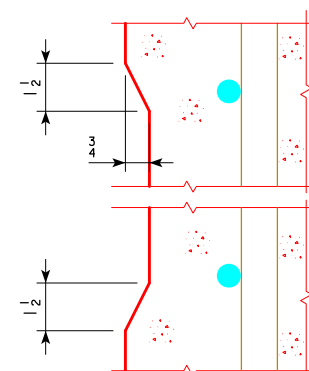

SECTION C-C

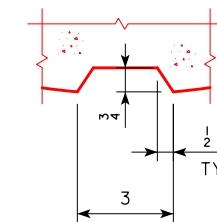

SECTION B-B

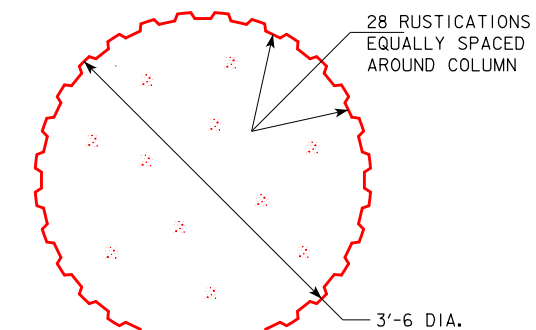

SECTION A-A

(REINFORCING NOT SHOWN)

NOTE: DO NOT ATTEMPT TO REMOVE COLUMN FORMS WITH RUSTICATION STRIPS STILL ATTACHED TO THE FORMS. SEE "CONCRETE RUSTICATION NOTES" FOR MORE INFORMATION AND OTHER REQUIREMENTS.

NOTE: FOR PIER DIMENSIONS AND DETAILS SEE DESIGN SHEETS 6-7.

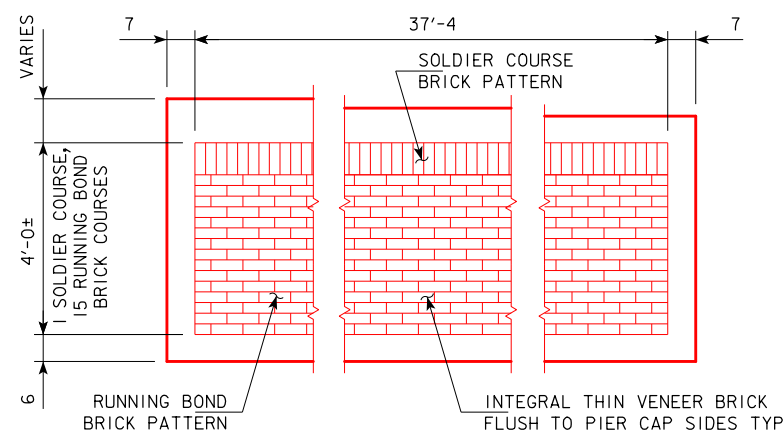

PIER CAP SIDE DETAIL

DESIGN FOR 16° SKEW (L.A.)
**252'-0 x 36'-0 PRETENSIONED
 PRESTRESSED CONCRETE BEAM BRIDGE**
 121'-0 S. SPAN 131'-0 N. SPAN
PIER AESTHETIC DETAILS
 STA. 8806+52.46 OCTOBER, 2016
LINN COUNTY
 IOWA DEPARTMENT OF TRANSPORTATION - HIGHWAY DIVISION
 DESIGN SHEET NO. 8 OF 31 FILE NO. 30839 DESIGN NO. 516