

A d d e n d u m

Iowa Department of Transportation
Office of Contracts

Date of Letting: November 15, 2016
Date of Addendum: November 14, 2016

| B.O. | Proposal ID | Proposal Work Type | County | Project Number | Addendum |
|-------------|--------------------|---------------------------|---------------|--|-----------------|
| 301 | 57-3806-556 | Slope Protection | Linn | MBIN-080-6(514)242--0M-52 MB-218-6(503)85--77-52 MBIN-380-6(515)4--0M-52 MB-30-6(508)253--77-57 MBIN-380-6(556)16--0M-57 | 15nov301a01 |

Make the following changes to the PLAN ATTACHMENTS:

For Project # MBIN-080-6(514)242--0M-52 REPLACE SHEET 6

For Project # MBIN-380-6(515)4--0M-52 REPLACE SHEETS 2 thru 6

For Project # MB-30-6(508)253--77-57 REPLACE SHEET 6

For Project # MBIN-380-6(556)16--0M-57 REPLACE SHEETS 2 thru 6

County: Johnson
 Project No: MBIN-080-6(514)242- -OM-52
 Work Type: SLOPE PROTECTION

1. Through traffic will be maintained on the project at all times. No lane closures will be allowed. Shoulder closure is allowed from 9:00 PM to 6:00AM Sunday night to Friday morning. All traffic control devices shall be removed from the traveled way at the end of each working day. Work will not be permitted on University of Iowa home football day as follows: (Sept 2, 16, and 23)(Oct 7 and 28)(Nov 4 and 18).
2. Traffic control on this project shall be in accordance with the following Standard Road Plans (English Version):
 TC-1 Revision Date 04-16-13
 TC-402 Revision Date 04-21-15

The applicable Standard Road Plan for a proposed work condition or situation shall be approved by the engineer in charge of construction.

For additional complementary information, refer to Part VI of the Manual on Uniform Traffic Control Devices and the current English Standard Specifications.

*** DEFINITION OF MAINTENANCE BRIDGE NUMBERS ***

THE NAMING CONVENTION FOR THE MAINTENANCE BRIDGE NUMBERS IS AS SHOWN FOR THE FOLLOWING EXAMPLE:

- . BRIDGE NO. 5210.90380:
- . (BRACKETED { } PORTIONS OF THE NUMBER ARE DEFINED BELOW.)
- . {52}10.90380 COUNTY NO. WHERE THE BRIDGE IS LOCATED
- . 52{10.9}0380 MILEPOST LOCATION - SHOWN ONLY UP TO 99.9
 (ACTUAL MILEPOST COULD BE 110.9 OR 210.9)
- . 5210.9{0}380 LOCATION OF BRIDGE RELATIVE TO THE ROUTE
 (ALPHA VALUES;
 O = OVER, R = RIGHT, L = LEFT,
 A = RAMP, S = SINGLE)
- . 5210.90{380} 3-DIGIT ROUTE

Coordinate work with the following projects:

- | | |
|----------------------------|-----------------------|
| IMN-80-7(104)254- -OE-16 | PCC Patching |
| IMN-80-6(321)205- -OE-48 | PCC Patching |
| IMN-80-6(322)240- -OE-52 | PCC Patching |
| MBIN-80-6(506)244- -O-M-52 | Bridge Painting |
| IMN-80-6(396)241- -OE-52 | PCC Pavement Widening |
| IMN-80-6(397)241- -OE-52 | Traffic Signals |

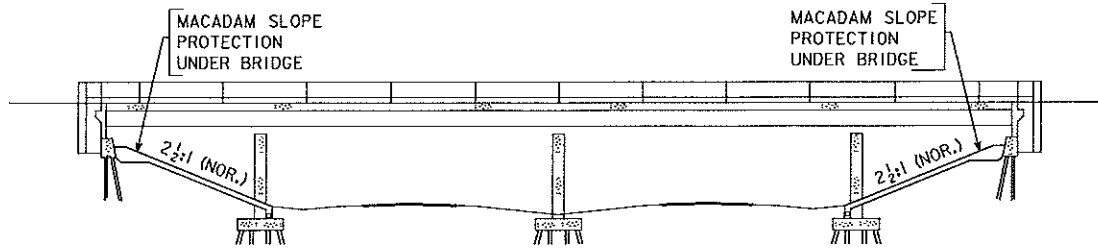

LONGITUDINAL SECTION ALONG C ROADWAY

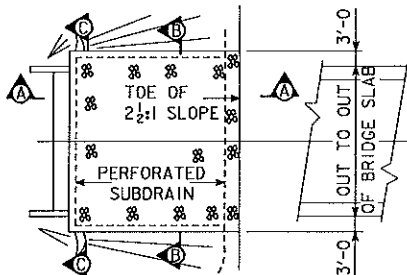

SLOPE PROTECTION LAYOUT 0° SKEW

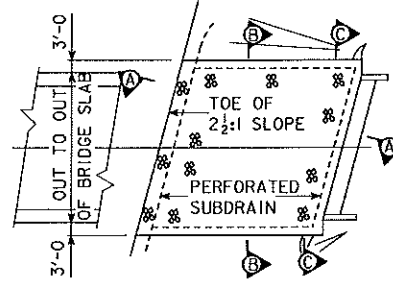

SLOPE PROTECTION LAYOUT 15° SKEW

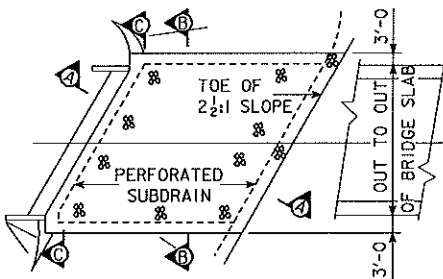

SLOPE PROTECTION LAYOUT 30° SKEW

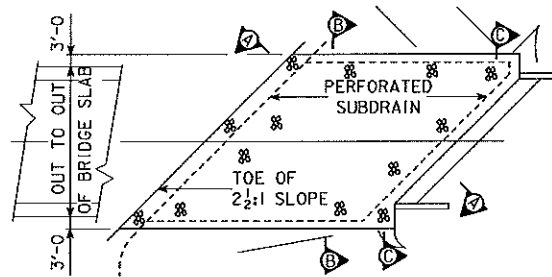

SLOPE PROTECTION LAYOUT 45° SKEW

REMOVAL NOTES :

THE EXISTING CONCRETE SLOPE PROTECTION SHALL BE REMOVED AND DISPOSED OF BY THE CONTRACTOR IN ACCORDANCE WITH SECTION 2401 OF THE STANDARD SPECIFICATIONS. ANY DAMAGE TO ANY PARTS OF THE EXISTING STRUCTURE NOT TO BE REMOVED SHALL BE THE RESPONSIBILITY OF THE CONTRACTOR AND REPAIRED BY THE CONTRACTOR AT NO ADDITIONAL COST TO THE STATE. ALL LABOR AND EQUIPMENT REQUIRED TO REMOVE AND DISPOSE OF THE EXISTING CONCRETE SLOPE PROTECTION AND ANY BACKFILLING OR REPAIR OF THE BERM THAT NEEDS TO TAKE PLACE BEFORE THE MACADAM STONE SLOPE PROTECTION CAN BE INSTALLED IS TO BE PAID FOR UNDER THE LUMP SUM BID ITEM "REMOVAL AS PER PLAN".

GENERAL NOTES :

THIS PLAN SHEET SHOWS DETAILS FOR PLACING A "MACADAM STONE SLOPE PROTECTION" UNDER OVERHEAD STRUCTURES.

THE BRIDGE BERM FORESLOPE SHALL BE COMPACTED AND SHAPED AS SHOWN ON THIS SHEET, SHAPING WILL INCLUDE EXCAVATION, FROM THE GRADING SURFACE SHOWN, THE SITUATION PLAN, AND AS DIRECTED BY THE ENGINEER. THE BERM FORESLOPE SHALL BE FIRM WHEN THE ENGINEERING FABRIC AND MACADAM STONE ARE PLACED.

THE ENGINEERING FABRIC SHALL BE IN ACCORDANCE WITH ARTICLE 4196.01, B, 3, OF THE STANDARD SPECIFICATIONS. IF THE ENGINEERING FABRIC IS LAPPED, THE LAPS SHALL BE A MINIMUM OF ONE FOOT IN LENGTH, SHINGLE FASHION WITH UP SLOPE LAP PIECE ON TOP AND STAPLED FOR CONTINUITY.

THE MACADAM STONE SHALL BE IN ACCORDANCE WITH SECTION 4122, OF THE STANDARD SPECIFICATIONS, COARSE MATERIAL (NO CHOKE STONE IS ALLOWED).

WOOD PRESERVATIVE TREATMENT FOR THE TIMBER EDGING SHALL MEET THE REQUIREMENTS FOR GUARDRAIL POSTS, SAWED FOUR SIDES, IN ACCORDANCE WITH SECTION 4161, OF THE STANDARD SPECIFICATIONS.

THE MACADAM STONE SHALL BE DEPOSITED, SPREAD, CONSOLIDATED AND SHAPED BY MECHANICAL OR HAND METHODS THAT WILL PROVIDE UNIFORM DEPTH AND DENSITY AND PROVIDE UNIFORM SURFACE APPEARANCE.

PAYMENT FOR "MACADAM STONE SLOPE PROTECTION" WILL BE MADE ON A SQUARE YARD BASIS FOR SLOPE PROTECTION CONSTRUCTED. THE UNIT PRICE BID PER SQUARE YARD SHALL INCLUDE ALL COSTS FOR MATERIAL AND LABOR REQUIRED TO CONSTRUCT THE SLOPE PROTECTION SHOWN ON THESE PLANS.

THE BERM FORESLOPE SHAPING AND COMPACTING AND THE DISPOSAL OF EXCESS SOIL FROM SHAPING OR TRENCHING SHALL BE CONSIDERED INCIDENTAL TO PLACING THE SLOPE PROTECTION.

WHERE EROSION CONTROL WORK HAS BEEN COMPLETED THE CONTRACTOR SHALL BE RESPONSIBLE FOR ANY PLANT MATERIALS DESTROYED ADJACENT TO THE SLOPE PROTECTION AREA. THE CONTRACTOR SHALL REPLANT, RESEED AND REMULCH ALL DISTURBED AREAS, DESIGNATED BY THE ENGINEER, IN ACCORDANCE WITH SECTION 2601, OF THE STANDARD SPECIFICATIONS, AT THE CONTRACTOR'S EXPENSE.

ITEMS TO BE INCLUDED IN "MACADAM STONE SLOPE PROTECTION":

- EXCAVATING, SHAPING AND COMPACTING
- ENGINEERING FABRIC
- MACADAM STONE
- 4" x 6" TREATED TIMBER EDGING
- 1/2" ϕ STEEL PINS (OR REBARS)
- POROUS BACKFILL OR GRANULAR SUBBASE BACKFILL AT FRONT FACE ABUTMENT FOOTING

BEFORE YOU DIG:
IOWA 1-CALL# 1-800-292-6989

ENGINEERING FABRIC ENDS ARE TO BE BURIED 6" TO PREVENT UNDERMINING



DETAIL "A"

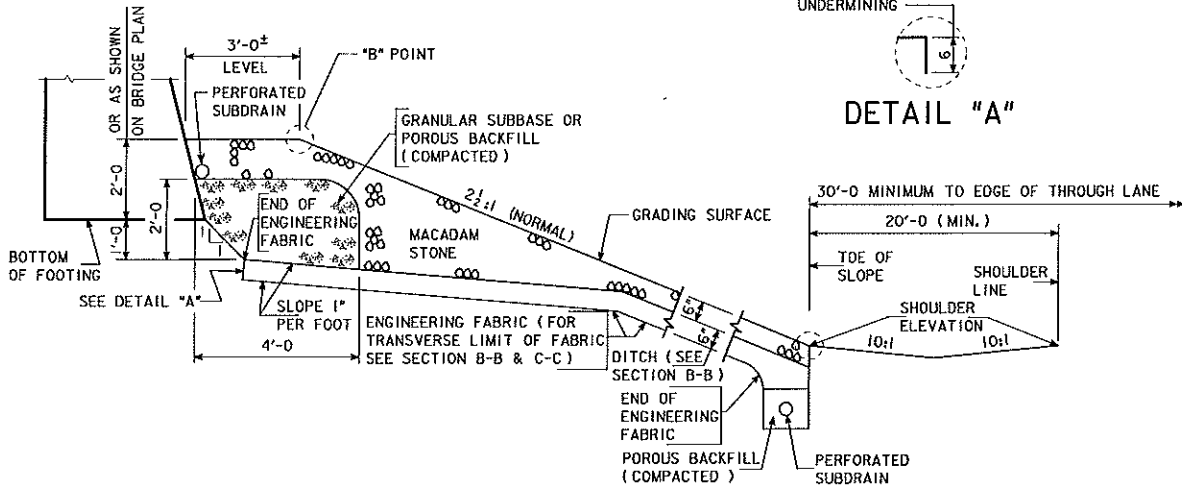

SECTION A-A

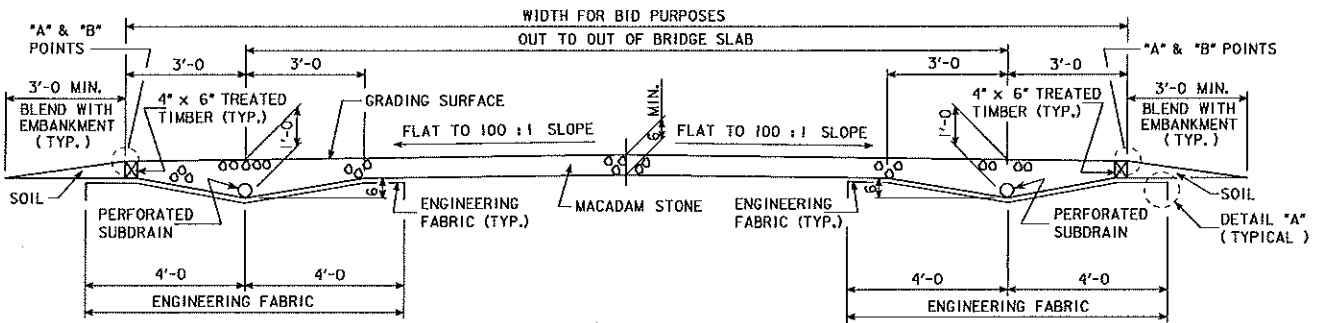

SECTION B-B

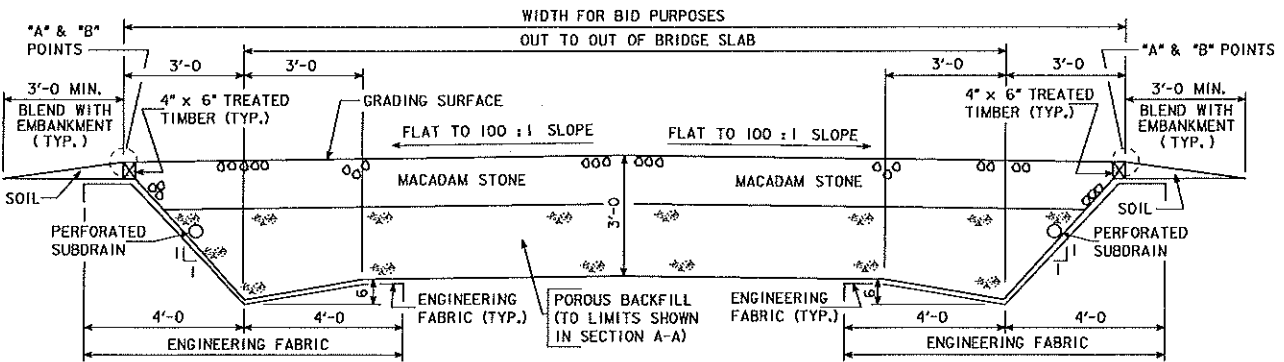

SECTION C-C

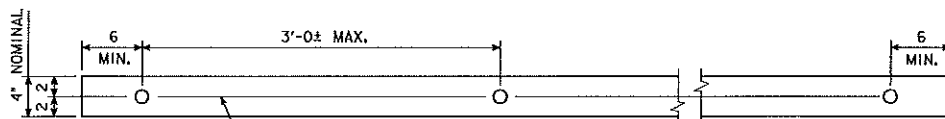

6" HOLES FOR 1/2" x 1'-6" STEEL PIN OR REBAR. DRIVE PIN OR REBAR VERTICALLY TO 1/2" (±) BELOW TOP SURFACE OF TREATED TIMBER

4 x 6 TREATED TIMBER EDGING DETAILS

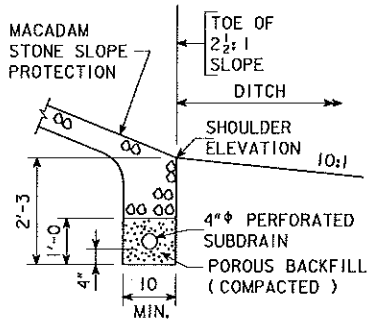

SECTION B-B

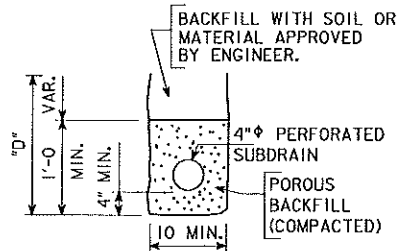

SECTION C-C
(TYPICAL)

"D" = DEPTH REQUIRED TO PROVIDE PROPER FLOW LINE FOR SUBDRAIN.

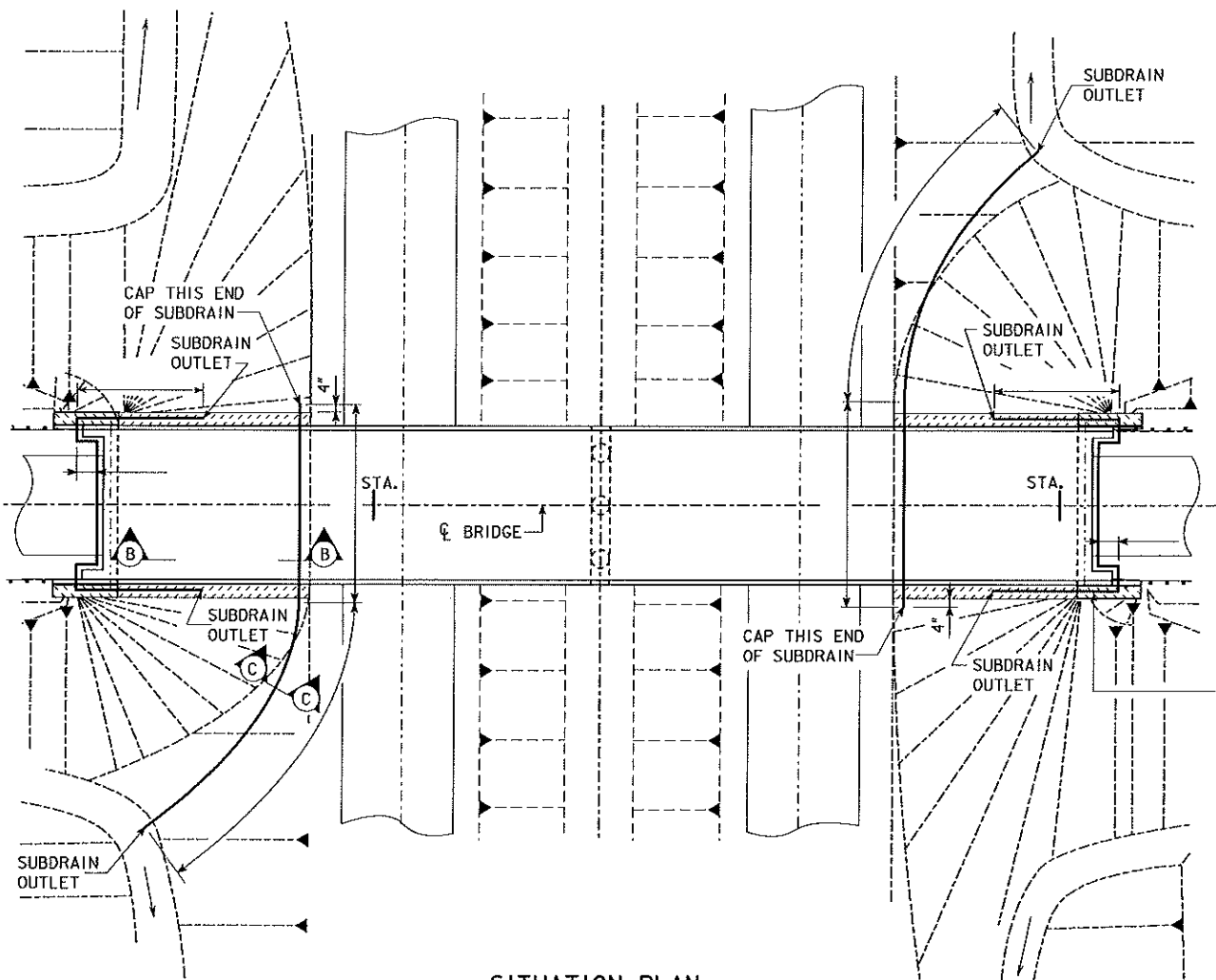

SITUATION PLAN

SUBDRAIN NOTES :

THIS PLAN SHEET SHOWS DETAILS FOR PLACING ALL SUBDRAINS AND SUBDRAIN OUTLETS REQUIRED FOR THIS STRUCTURE.

THE SUBDRAINS SHALL BE 4" IN DIAMETER AND SHALL BE IN ACCORDANCE WITH ARTICLE 4143.01, B, OF THE STANDARD SPECIFICATIONS. THE SUBDRAIN OUTLET SHALL CONSIST OF A 6'-0 LENGTH OF PIPE WITH A REMOVABLE RODENT GUARD AS DETAILED ON THIS SHEET.

THE COST OF FURNISHING AND PLACING SUBDRAIN(INCLUDING EXCAVATION), GRANULAR BACKFILL, POROUS BACKFILL, AND SUBDRAIN OUTLET IS TO BE INCLUDED IN THE PRICE BID "MACADAM STONE SLOPE PROTECTION". NO EXTRA PAYMENT WILL BE MADE.

DUE TO FIELD ADJUSTMENTS OF THE GRADING LAYOUT.

THE UPHILL END OF THE PERFORATED SUBDRAIN AT THE TOE OF SLOPE PROTECTION SHALL BE CAPPED AS APPROVED BY THE ENGINEER.

THE POROUS BACKFILL AND SUBDRAIN ARE TO BE CARRIED AROUND PIER COLUMNS IF THE COLUMN PLACEMENT INTERFERES WITH ALIGNMENT OF SUBDRAIN AS SHOWN ON THIS SHEET.

EROSION CONTROL :

FOLLOWING COMPLETION OF WORK ON THIS PROJECT; SEEDING, FERTILIZING AND MULCHING OF ALL DISTURBED AREAS SHALL BE DONE AS DIRECTED BY THE ENGINEER.

SEEDING:

3 LBS. OF FESQUE, KENTUCKY 31 OR FAWN PER 1000 SQ. FT.

FERTILIZER:

17 LBS. OF 13-13-13 (OR EQUIVALENT) COMMERCIAL FERTILIZER PER 1000 SQ. FT.

MULCH:

70 LBS. OF DRY CEREAL STRAW PER 1000 SQ. FT. ALL MULCH TO BE CONSOLIDATED INTO SOIL WITH THE MULCH STABILIZER.

THE PREPARATION OF THE SEEDBED, FURNISHED AND APPLICATION OF SEED, FERTILIZER AND MULCH TO ALL DISTURBED AREAS ON THIS PROJECT SHALL BE CONSIDERED INCIDENTAL TO WORK ON THIS PROJECT AND NO EXTRA COMPENSATION WILL BE ALLOWED.

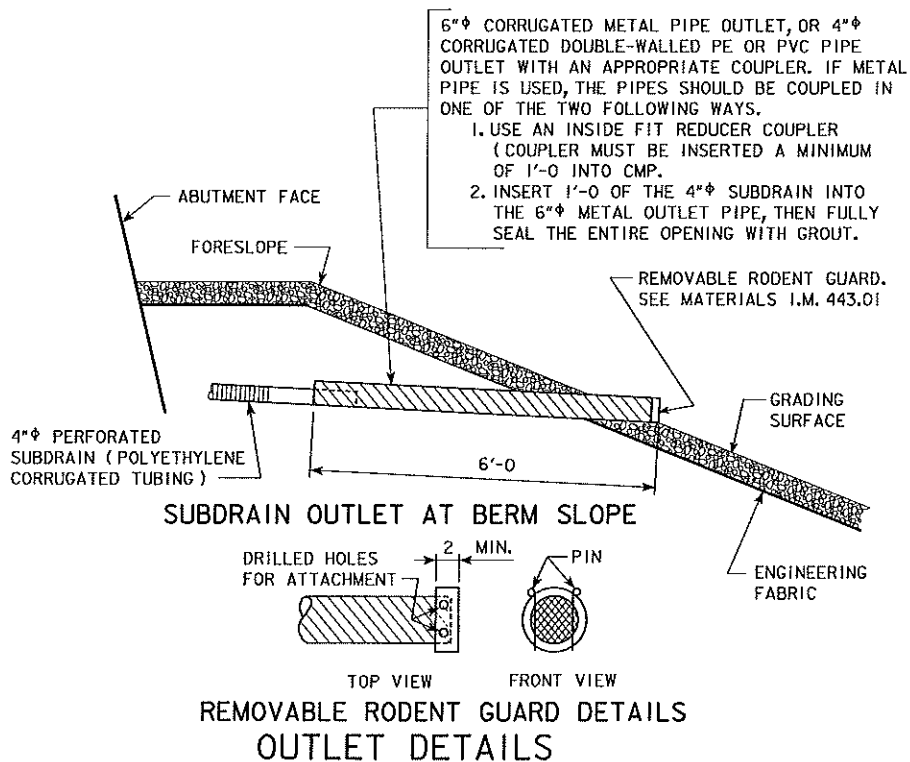

County: Johnson
 Project No: MBIN-380-6(515)4- -OM-52
 Work Type: SLOPE PROTECTION

1. Through traffic will be maintained on the project at all times. No lane closures will be allowed. Shoulder closures on I-380 will be permitted from 9:00 a.m. to 3:00 p.m. and from 7:00 p.m. to 6 a.m., except on University of Iowa home football game days. Shoulder closures outside of these hours will not be permitted. All traffic control devices shall be removed from the traveled way at the end of each working day. Work will not be permitted on University of Iowa home football days as follows: (Sept 2, 16, and 23)(Oct 7 and 28)(Nov 4 and 18).
2. Traffic control on this project shall be in accordance with the following Standard Road Plans (English Version):
 - TC-1 Revision Date 04-16-13
 - TC-402 Revision Date 04-21-15

The applicable Standard Road Plan for a proposed work condition or situation shall be approved by the engineer in charge of construction.

For additional complementary information, refer to Part VI of the Manual on Uniform Traffic Control Devices and the current English Standard Specifications.

*** DEFINITION OF MAINTENANCE BRIDGE NUMBERS ***
 THE NAMING CONVENTION FOR THE MAINTENANCE BRIDGE NUMBERS IS AS SHOWN FOR THE FOLLOWING EXAMPLE:
 . BRIDGE NO. 5210.90380:
 . (BRACKETED { } PORTIONS OF THE NUMBER ARE DEFINED BELOW.)
 . {52}10.90380 COUNTY NO. WHERE THE BRIDGE IS LOCATED
 . 52{10.9}0380 MILEPOST LOCATION - SHOWN ONLY UP TO 99.9
 . (ACTUAL MILEPOST COULD BE 110.9 OR 210.9)
 . 5210.9{0}380 LOCATION OF BRIDGE RELATIVE TO THE ROUTE
 . (ALPHA VALUES;
 . O = OVER, R = RIGHT, L = LEFT,
 . A = RAMP, S = SINGLE)
 . 5210.90{380} 3-DIGIT ROUTE

Coordinate work with the following projects:

| | |
|--------------------------|------------------------|
| IMN-380-6(282)0- -OE-52 | PCC Patching |
| IMN-380-6(296)0- -OE-52 | Culvert Repairs |
| IMN-380-6(294)15- -OE-57 | Culvert Repairs |
| IM-380-6 (303)2- -13-52 | Pavement-Grade and New |
| IM-380-6 (304)2- -13-52 | Bridge |

County: Linn
Project No: MB-030-6(508)253- -77-57
Work Type: SLOPE PROTECTION

- 1. Through traffic will be maintained on the project at all times. No lane closures will be allowed. Shoulder closures and partial lane closures on ramps will be permitted from 9 a.m. to 3:00 p.m. and from 7:00 p.m. to 6:00 a.m. Shoulder closures outside of these hours will not be permitted. All traffic control devices shall be removed from the traveled way at the end of each working day. Coordinate work with the following projects:

| | |
|---------------------------|------------------|
| MP-30-6(724)245- -76-57 | PCC Patching |
| MBIN-380-6(556)16- -OM-57 | Slope Protection |
| IMN-380-6(282)0- -OE-52 | PCC Patching |

- 2. Traffic control on this project shall be in accordance with the following Standard Road Plans (English Version):

| | |
|--------|------------------------|
| TC-1 | Revision Date 04-16-13 |
| TC-402 | Revision Date 04-21-15 |

The applicable Standard Road Plan for a proposed work condition or situation shall be approved by the engineer in charge of construction.

For additional complementary information, refer to Part VI of the Manual on Uniform Traffic Control Devices and the current English Standard Specifications.

*** DEFINITION OF MAINTENANCE BRIDGE NUMBERS ***
 THE NAMING CONVENTION FOR THE MAINTENANCE BRIDGE NUMBERS IS AS SHOWN FOR THE FOLLOWING EXAMPLE:

| | |
|---|---|
| . BRIDGE NO. 5210.90380: | |
| . (BRACKETED { } PORTIONS OF THE NUMBER ARE DEFINED BELOW.) | |
| . {52}10.90380 | COUNTY NO. WHERE THE BRIDGE IS LOCATED |
| . 52{10.9}0380 | MILEPOST LOCATION - SHOWN ONLY UP TO 99.9 (ACTUAL MILEPOST COULD BE 110.9 OR 210.9) |
| . 5210.9{0}380 | LOCATION OF BRIDGE RELATIVE TO THE ROUTE (ALPHA VALUES; |
| . . | O = OVER, R = RIGHT, L = LEFT, |
| . . | A = RAMP, S = SINGLE) |
| . 5210.90{380} | 3-DIGIT ROUTE |

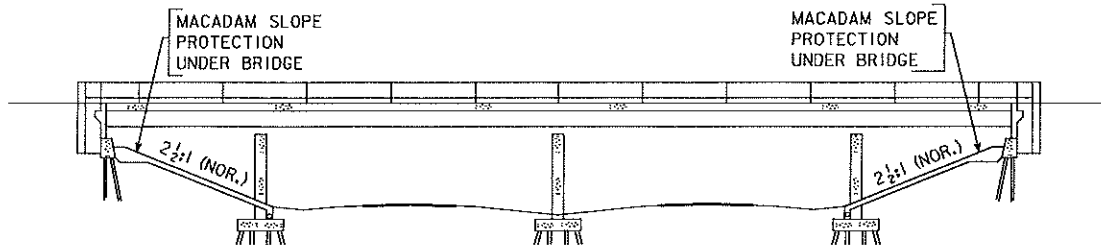

LONGITUDINAL SECTION ALONG CL ROADWAY

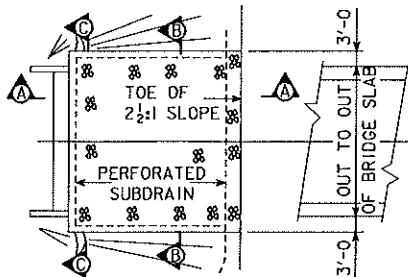

SLOPE PROTECTION LAYOUT 0° SKEW

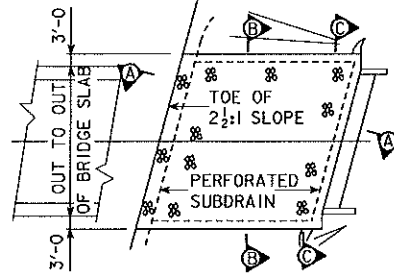

SLOPE PROTECTION LAYOUT 15° SKEW

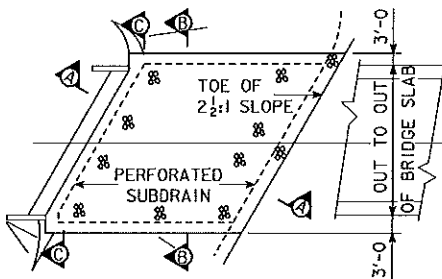

SLOPE PROTECTION LAYOUT 30° SKEW

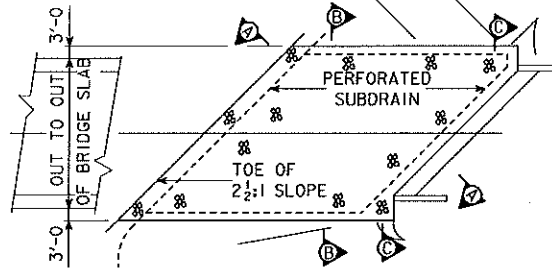

SLOPE PROTECTION LAYOUT 45° SKEW

REMOVAL NOTES :

THE EXISTING CONCRETE SLOPE PROTECTION SHALL BE REMOVED AND DISPOSED OF BY THE CONTRACTOR IN ACCORDANCE WITH SECTION 2401 OF THE STANDARD SPECIFICATIONS. ANY DAMAGE TO ANY PARTS OF THE EXISTING STRUCTURE NOT TO BE REMOVED SHALL BE THE RESPONSIBILITY OF THE CONTRACTOR AND REPAIRED BY THE CONTRACTOR AT NO ADDITIONAL COST TO THE STATE. ALL LABOR AND EQUIPMENT REQUIRED TO REMOVE AND DISPOSE OF THE EXISTING CONCRETE SLOPE PROTECTION AND ANY BACKFILLING OR REPAIR OF THE BERM THAT NEEDS TO TAKE PLACE BEFORE THE MACADAM STONE SLOPE PROTECTION CAN BE INSTALLED IS TO BE PAID FOR UNDER THE LUMP SUM BID ITEM "REMOVAL AS PER PLAN".

GENERAL NOTES :

THIS PLAN SHEET SHOWS DETAILS FOR PLACING A "MACADAM STONE SLOPE PROTECTION" UNDER OVERHEAD STRUCTURES.

THE BRIDGE BERM FORESLOPE SHALL BE COMPACTED AND SHAPED AS SHOWN ON THIS SHEET, SHAPING WILL INCLUDE EXCAVATION, FROM THE GRADING SURFACE SHOWN, THE SITUATION PLAN, AND AS DIRECTED BY THE ENGINEER. THE BERM FORESLOPE SHALL BE FIRM WHEN THE ENGINEERING FABRIC AND MACADAM STONE ARE PLACED.

THE ENGINEERING FABRIC SHALL BE IN ACCORDANCE WITH ARTICLE 4196.01, B, 3, OF THE STANDARD SPECIFICATIONS. IF THE ENGINEERING FABRIC IS LAPPED, THE LAPS SHALL BE A MINIMUM OF ONE FOOT IN LENGTH, SHINGLE FASHION WITH UP SLOPE LAP PIECE ON TOP AND STAPLED FOR CONTINUITY.

THE MACADAM STONE SHALL BE IN ACCORDANCE WITH SECTION 4122, OF THE STANDARD SPECIFICATIONS, COARSE MATERIAL (NO CHOKE STONE IS ALLOWED). WOOD PRESERVATIVE TREATMENT FOR THE TIMBER EDGING SHALL MEET THE REQUIREMENTS FOR GUARDRAIL POSTS, SAWED FOUR SIDES, IN ACCORDANCE WITH SECTION 4161, OF THE STANDARD SPECIFICATIONS.

THE MACADAM STONE SHALL BE DEPOSITED, SPREAD, CONSOLIDATED AND SHAPED BY MECHANICAL OR HAND METHODS THAT WILL PROVIDE UNIFORM DEPTH AND DENSITY AND PROVIDE UNIFORM SURFACE APPEARANCE.

PAYMENT FOR "MACADAM STONE SLOPE PROTECTION" WILL BE MADE ON A SQUARE YARD BASIS FOR SLOPE PROTECTION CONSTRUCTED. THE UNIT PRICE BID PER SQUARE YARD SHALL INCLUDE ALL COSTS FOR MATERIAL AND LABOR REQUIRED TO CONSTRUCT THE SLOPE PROTECTION SHOWN ON THESE PLANS.

THE BERM FORESLOPE SHAPING AND COMPACTING AND THE DISPOSAL OF EXCESS SOIL FROM SHAPING OR TRENCHING SHALL BE CONSIDERED INCIDENTAL TO PLACING THE SLOPE PROTECTION.

WHERE EROSION CONTROL WORK HAS BEEN COMPLETED THE CONTRACTOR SHALL BE RESPONSIBLE FOR ANY PLANT MATERIALS DESTROYED ADJACENT TO THE SLOPE PROTECTION AREA. THE CONTRACTOR SHALL REPLANT, RESEED AND REMULCH ALL DISTURBED AREAS, DESIGNATED BY THE ENGINEER, IN ACCORDANCE WITH SECTION 2601, OF THE STANDARD SPECIFICATIONS, AT THE CONTRACTOR'S EXPENSE.

ITEMS TO BE INCLUDED IN "MACADAM STONE SLOPE PROTECTION":

- EXCAVATING, SHAPING AND COMPACTING
- ENGINEERING FABRIC
- MACADAM STONE
- 4" x 6" TREATED TIMBER EDGING
- 1/2" φ STEEL PINS (OR REBARS)
- POROUS BACKFILL OR GRANULAR SUBBASE BACKFILL AT FRONT FACE ABUTMENT FOOTING

BEFORE YOU DIG:
IOWA 1-CALL# 1-800-292-8989

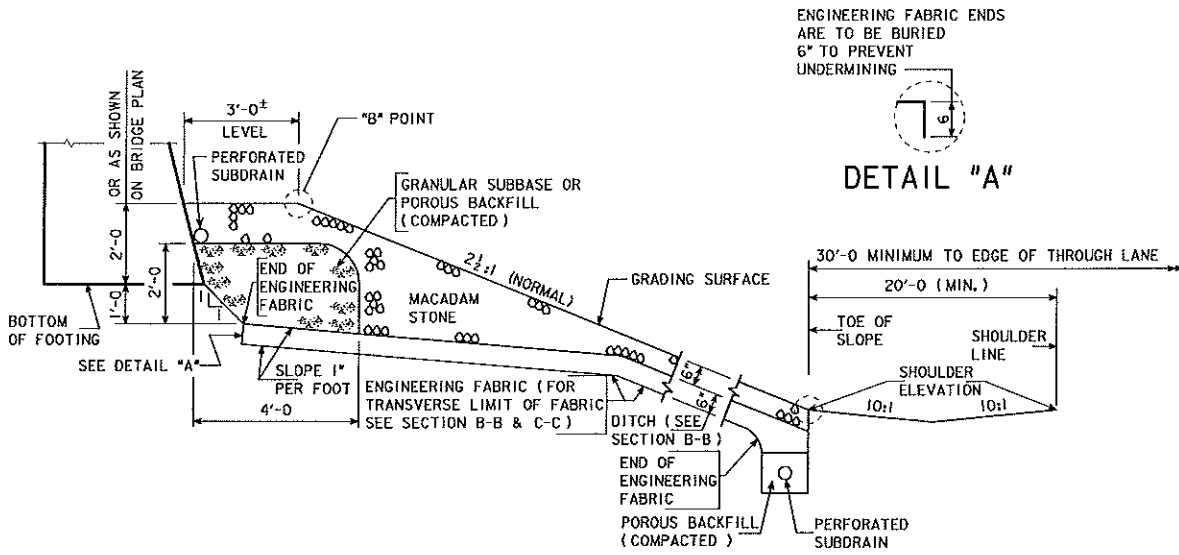

SECTION A-A

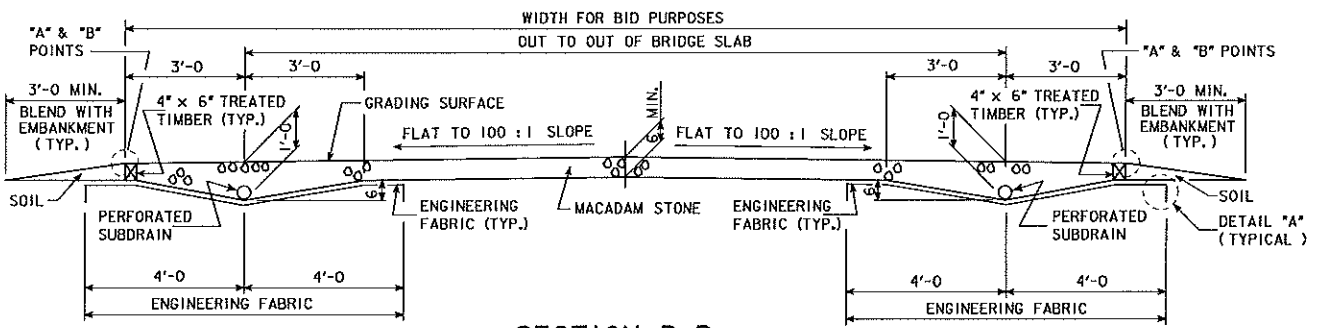

SECTION B-B

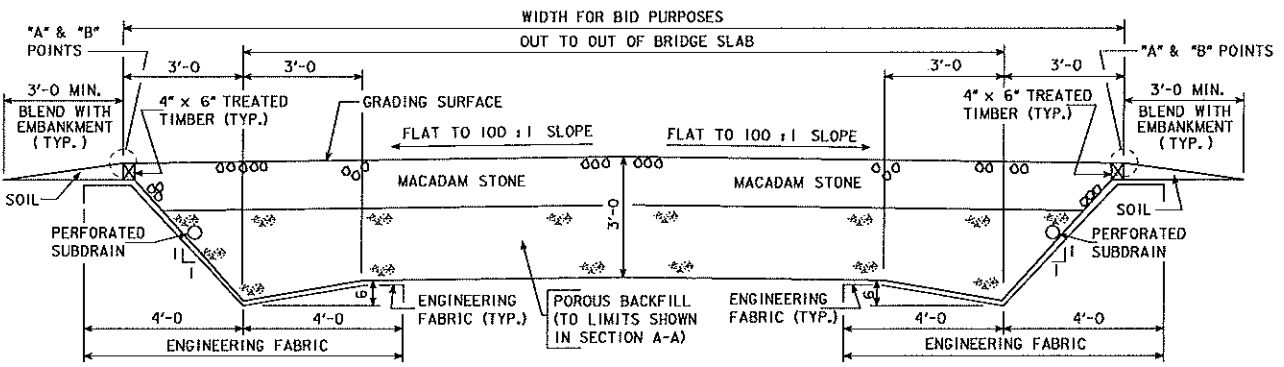

SECTION C-C

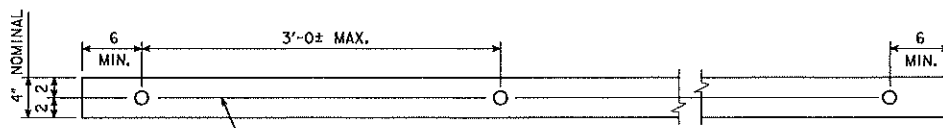

4 x 6 TREATED TIMBER EDGING DETAILS

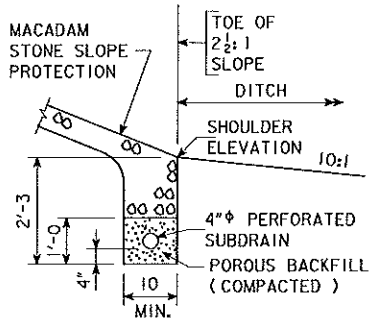

SECTION B-B

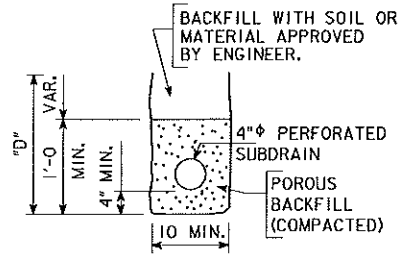

SECTION C-C
(TYPICAL)

"D" = DEPTH REQUIRED TO PROVIDE PROPER FLOW LINE FOR SUBDRAIN.

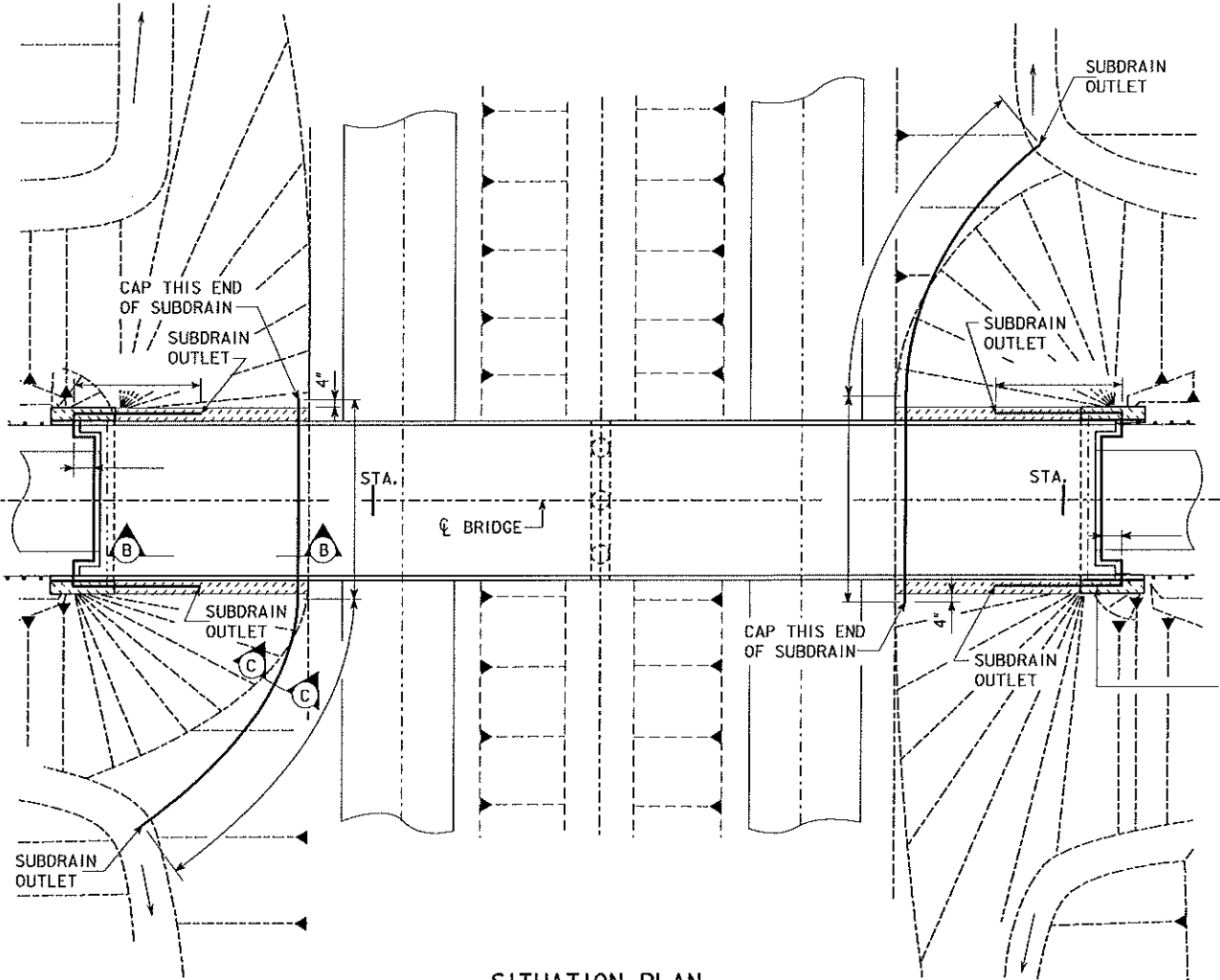

SITUATION PLAN

SUBDRAIN NOTES :

THIS PLAN SHEET SHOWS DETAILS FOR PLACING ALL SUBDRAINS AND SUBDRAIN OUTLETS REQUIRED FOR THIS STRUCTURE.

THE SUBDRAINS SHALL BE 4" IN DIAMETER AND SHALL BE IN ACCORDANCE WITH ARTICLE 4143.01, B, OF THE STANDARD SPECIFICATIONS. THE SUBDRAIN OUTLET SHALL CONSIST OF A 6'-0 LENGTH OF PIPE WITH A REMOVABLE RODENT GUARD AS DETAILED ON THIS SHEET.

THE COST OF FURNISHING AND PLACING SUBDRAIN(INCLUDING EXCAVATION), GRANULAR BACKFILL, POROUS BACKFILL, AND SUBDRAIN OUTLET IS TO BE INCLUDED IN THE PRICE BID "MACADAM STONE SLOPE PROTECTION". NO EXTRA PAYMENT WILL BE MADE.

DUE TO FIELD ADJUSTMENTS OF THE GRADING LAYOUT.

THE UPHILL END OF THE PERFORATED SUBDRAIN AT THE TOE OF SLOPE PROTECTION SHALL BE CAPPED AS APPROVED BY THE ENGINEER.

THE POROUS BACKFILL AND SUBDRAIN ARE TO BE CARRIED AROUND PIER COLUMNS IF THE COLUMN PLACEMENT INTERFERES WITH ALIGNMENT OF SUBDRAIN AS SHOWN ON THIS SHEET.

EROSION CONTROL :

FOLLOWING COMPLETION OF WORK ON THIS PROJECT; SEEDING, FERTILIZING AND MULCHING OF ALL DISTURBED AREAS SHALL BE DONE AS DIRECTED BY THE ENGINEER.

SEEDING:

3 LBS. OF FESQUE, KENTUCKY 31 OR FAWN PER 1000 SQ. FT.

FERTILIZER:

17 LBS. OF 13-13-13 (OR EQUIVALENT) COMMERCIAL FERTILIZER PER 1000 SQ. FT.

MULCH:

70 LBS. OF DRY CEREAL STRAW PER 1000 SQ. FT. ALL MULCH TO BE CONSOLIDATED INTO SOIL WITH THE MULCH STABILIZER.

THE PREPARATION OF THE SEEDBED, FURNISHED AND APPLICATION OF SEED, FERTILIZER AND MULCH TO ALL DISTURBED AREAS ON THIS PROJECT SHALL BE CONSIDERED INCIDENTAL TO WORK ON THIS PROJECT AND NO EXTRA COMPENSATION WILL BE ALLOWED.

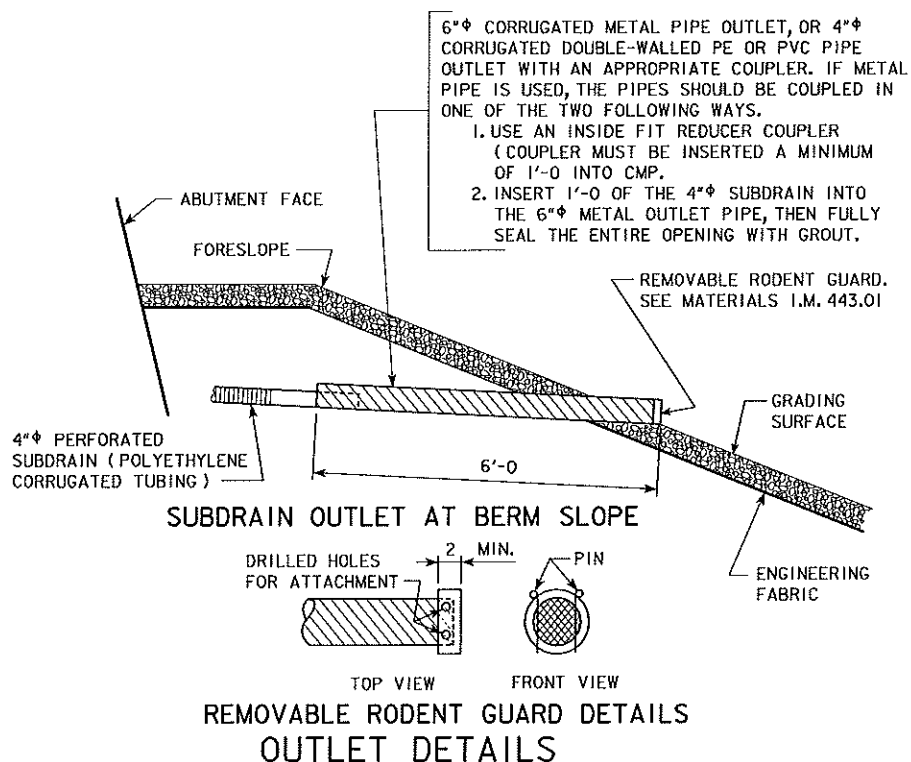

County: Linn
 Project No: MBIN-380-6(556)16- -OM-57
 Work Type: SLOPE PROTECTION

- Through traffic will be maintained on the project at all times. No lane closures will be allowed. Shoulder closures on I-380 will be permitted from 9:00 a.m. to 3:00 p.m. and from 7:00 p.m. to 6:00 a.m., except on University of Iowa home football game days. Shoulder closures outside of these hours will not be permitted. All traffic control devices shall be removed from the traveled way at the end of each working day. Work will not be permitted on University of Iowa home football days as follows: (Sept 2, 16 and 23)(Oct 7 and 28)(Nov 4 and 18). Coordinate work with the following projects:

| | |
|--------------------------|---------------------|
| IMN-380-6(290)19- -OE-57 | Bridge Deck Overlay |
| IMN-380-6(282)0- -OE-52 | PCC Patching |
| IMN-380-6(296)0- -OE-52 | Culvert Repairs |
| IMN-380-6(294)15- -OE-57 | Culvert Repairs |
| MB-30-6(508)253- -77-57 | Slope Protection |
| MP-30-6(724)245- -76-57 | PCC Patching |
| IMN-000-5(577)0- -OE-00 | Guardrail |

- Traffic control on this project shall be in accordance with the following Standard Road Plans (English Version):
 - TC-1 Revision Date 04-16-13
 - TC-402 Revision Date 04-21-15

The applicable Standard Road Plan for a proposed work condition or situation shall be approved by the engineer in charge of construction.

For additional complementary information, refer to Part VI of the Manual on Uniform Traffic Control Devices and the current English Standard Specifications.

*** DEFINITION OF MAINTENANCE BRIDGE NUMBERS ***
 THE NAMING CONVENTION FOR THE MAINTENANCE BRIDGE NUMBERS IS AS SHOWN FOR THE FOLLOWING EXAMPLE:
 . BRIDGE NO. 5210.90380:
 . (BRACKETED { } PORTIONS OF THE NUMBER ARE DEFINED BELOW.)
 . {52}10.90380 COUNTY NO. WHERE THE BRIDGE IS LOCATED
 . 52{10.9}0380 MILEPOST LOCATION - SHOWN ONLY UP TO 99.9
 . (ACTUAL MILEPOST COULD BE 110.9 OR 210.9)
 . 5210.9{0}380 LOCATION OF BRIDGE RELATIVE TO THE ROUTE
 . (ALPHA VALUES;
 . O = OVER, R = RIGHT, L = LEFT,
 . A = RAMP, S = SINGLE)
 . 5210.90{380} 3-DIGIT ROUTE