

SURVEY NO. 1
FIBROUS CONCRETE RESURFACING
GREENE COUNTY, IOWA

April, 1974

Iowa State Highway Commission
Research Department
Project HR-165

17-H53R
9:F444

17-H53R

9: F443

IOWA STATE HIGHWAY COMMISSION
Ames, Iowa
Research Department

Research Project HR-165
FIBROUS CONCRETE, GREENE COUNTY, IOWA

The three miles of fibrous concrete resurfacing in Greene County, Iowa were placed in September and early October, 1973. It was recognized in advance that cracking and other performance characteristics of the fibrous concrete sections and of the central sections would be major factors in the evaluation of the project.

A low level aerial survey was made of the old pavement. During construction of the resurfacing, the aerial survey was checked to insure that cracks in the old pavement were referenced to the 100 ft. station marks placed in the resurfacing.

The crack survey recorded herein was made in March and April, 1974. Those cracks in the resurfacing that are reflections of cracks in the underlying slab are identified by \wedge marks.

Observations (not detailed crack surveys) made in June, 1974 indicate that further cracking of the resurfacing has occurred since this report was prepared. In particular, there appears to be some additional longitudinal cracking over the widening joints.

FIBROUS SECTIONS

AS BUILT

Fiber Size (in.)		1												2 1/2											
Fiber Content (lbs.)		60				100				160				60				100				160			
Admixture Type		O	N	R	O	N	R	O	N	R	O	N	R	O	N	R	O	N	R	O	N	R			
3	600	U																							
		B																							
		P	7	13		9	24		18	19		16	37												
		U																							
		B																							
		P																							
	750	U																							
		B																							
		P																							
		U																							
		B																							
		P																							
500+ 234 FA	U																								
	B																								
	P																								
	U																								
	B																								
	P																								
2	600	U																							
		B																							
		P																							
		U																							
		B																							
		P																							
	750	U																							
		B																							
		P																							
		U																							
		B																							
		P																							
500+ 234 FA	U																								
	B																								
	P																								
	U																								
	B																								
	P																								

<table border="1" style="width: 100%; border-collapse: collapse;"> <tr> <td style="text-align: center;">Pavement Thick. (in.)</td> <td style="text-align: center;">Cement Content (lbs.)</td> <td style="text-align: center;">Bonding Condition</td> </tr> </table>	Pavement Thick. (in.)	Cement Content (lbs.)	Bonding Condition	<p style="text-align: center;"><u>Admixture</u></p> <p>O None N Water Reducer R Set Retarder</p>	<p style="text-align: center;"><u>Bonding</u></p> <p>P Partial B Bonded U Unbonded</p>
Pavement Thick. (in.)	Cement Content (lbs.)	Bonding Condition			

NON-FIBROUS SECTIONS

Sections 1 and 39 5 in. Type A Plain Partial Bond No Admix.	Sections 2 and 38 4 in. Type A 6x6 Mesh Partial Bond No Admix.	Section 3 4 in. Type A CRC Mesh Anchor Bonded No Admix.	Section 4 4 in. Type A CRC Mesh Unbonded No Admix.	Section 5 3 in. Type A CRC Mesh Unbonded No Admix.	Section 6 3 in. Type A CRC Mesh Anchor Bonded No Admix.
---	--	---	---	---	---

00
+
0

Section 1
Reflected Crack \wedge

Pavement - A-4
Bond - Partial
Cement - 569 lb.
Thickness - 5"

N



0

Contraction Joint

1

2

Scale 1" = 20'



Section 1
Reflected Crack ^

|
2

|
3

|
4



4 + 04

Transition

4 + 67

Section 2
(Mesh)

Reflected Crack ^

Pavement - A-4
Bond - Partial
Cement - 569 lb.
Thickness - 4"

N

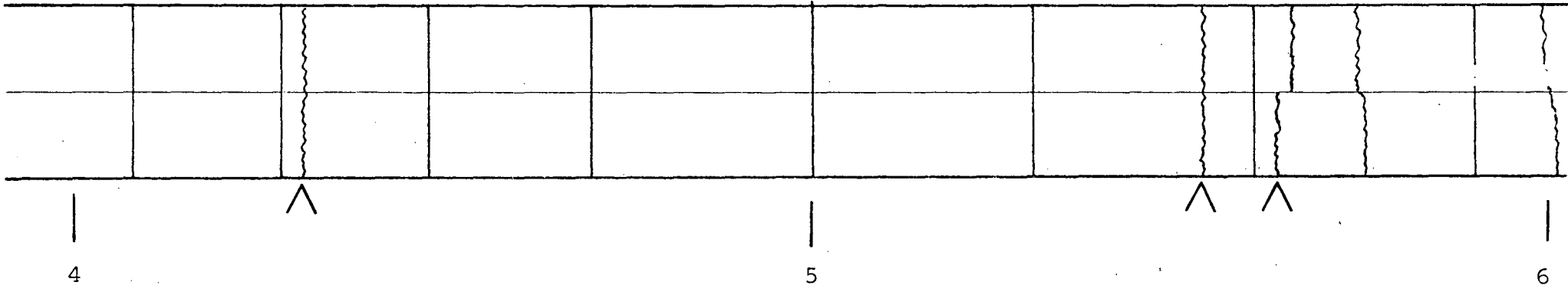

4

5

6

N



Section 2
Reflected Crack ^

V

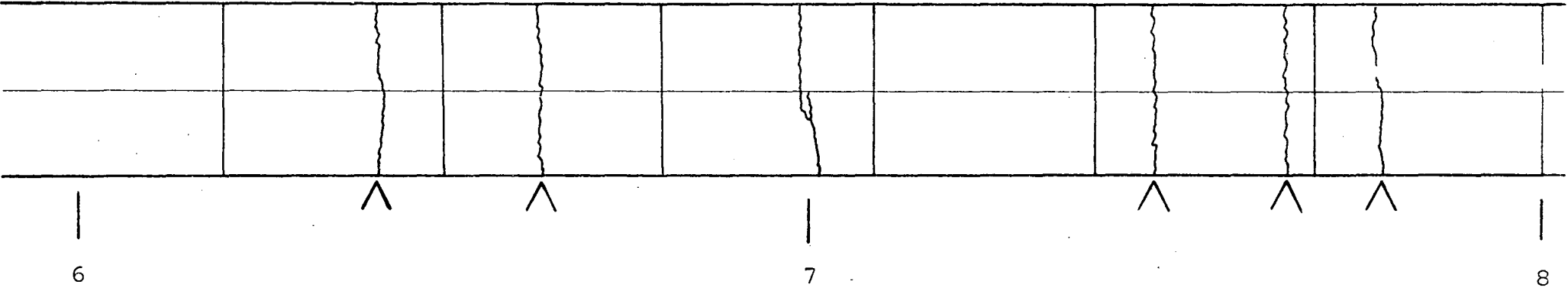

Section 2
Reflected Crack 

8 + 99

Section 3
(CRC Anchor)

Pavement - A-4
Bond - Bonded
Cement - 569 lb.
Thickness - 4"

N

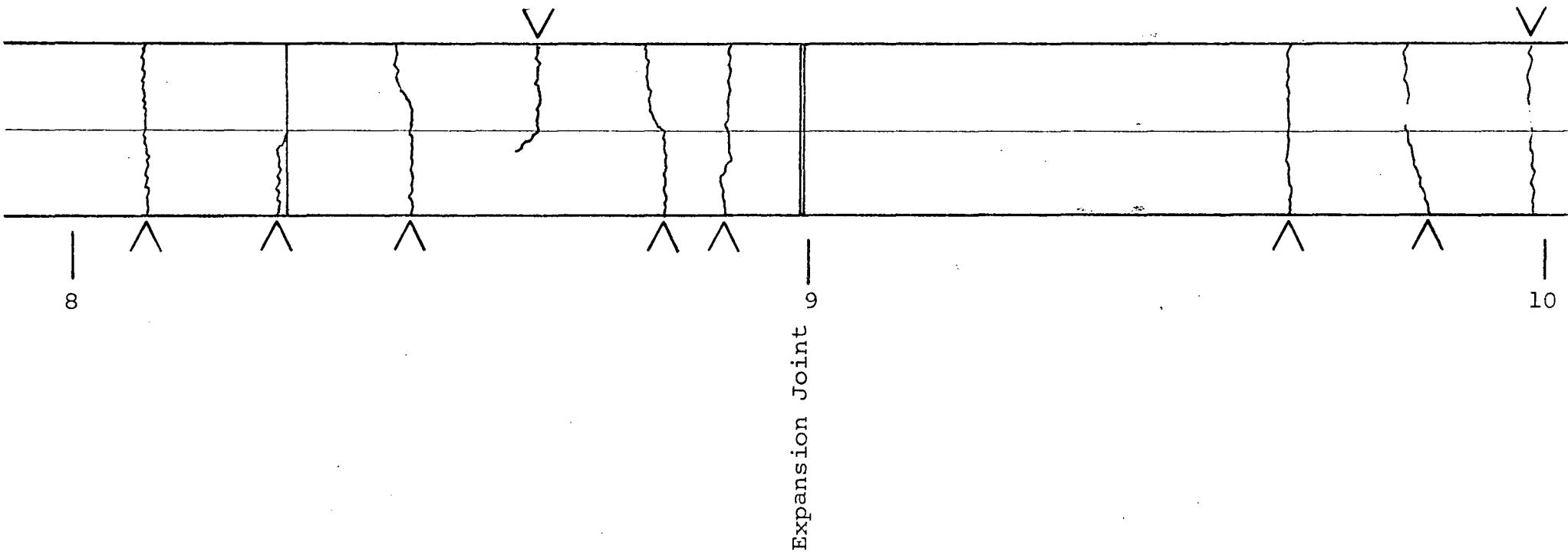

Section 3
Reflected Crack ^

10 + 98

Section 4
(CRC)

Pavement - A-4
Bond - Unbonded
Cement - 569 lb.
Thickness - 4"

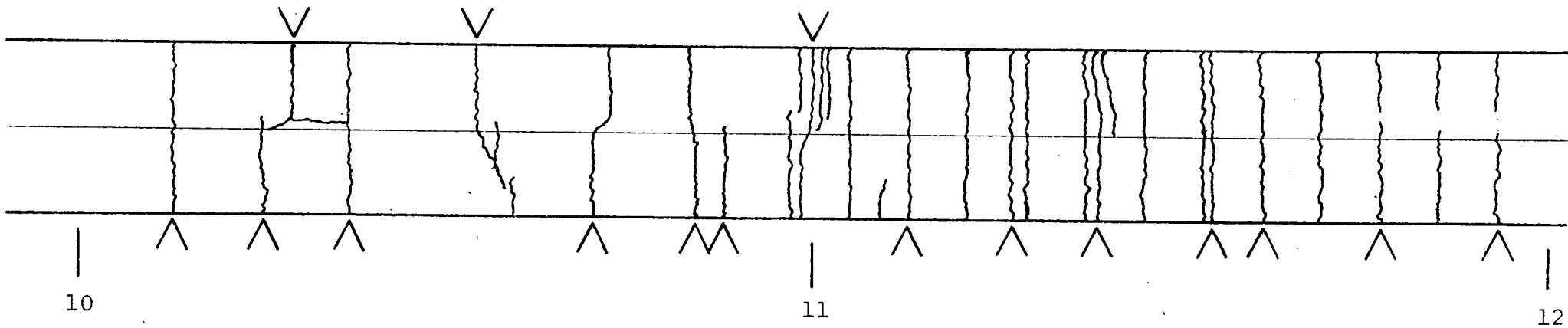

10

11

12

Section 4
Reflected Crack ^

N

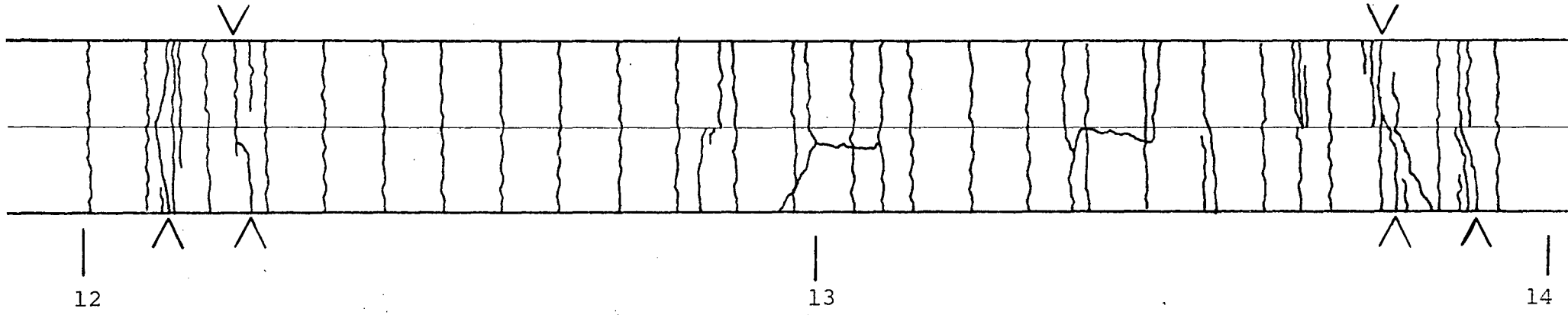

Section 4
Reflected Crack ^

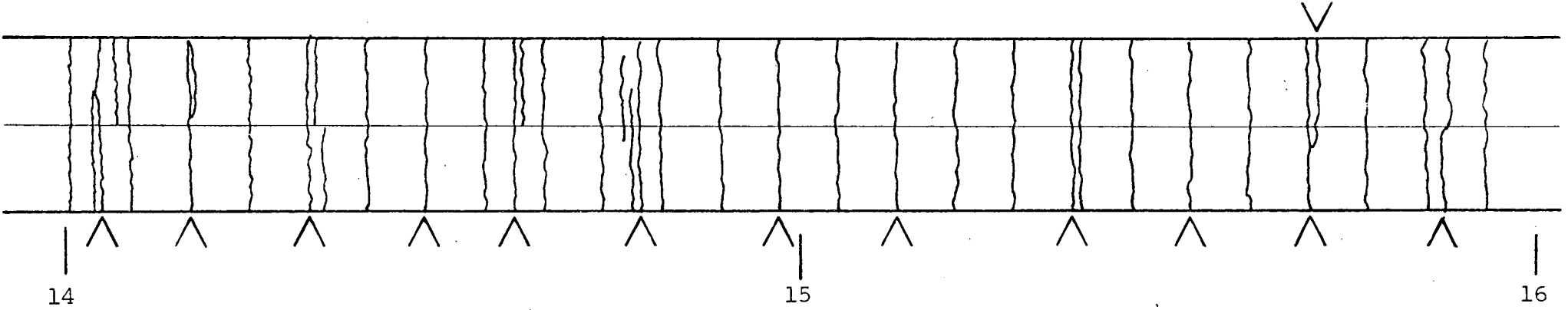

Section 4
Reflected Crack ^

16 + 65

Transition

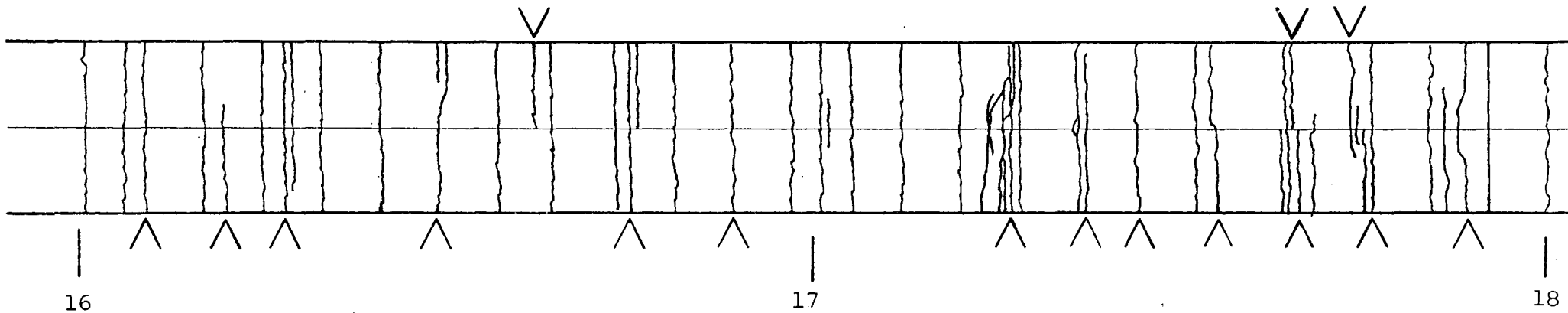

16

17

18



Section 5
(CRC)
Reflected Crack ^

Pavement - A-4
Bond - Unbonded
Cement - 569 lb.
Thickness - 3"

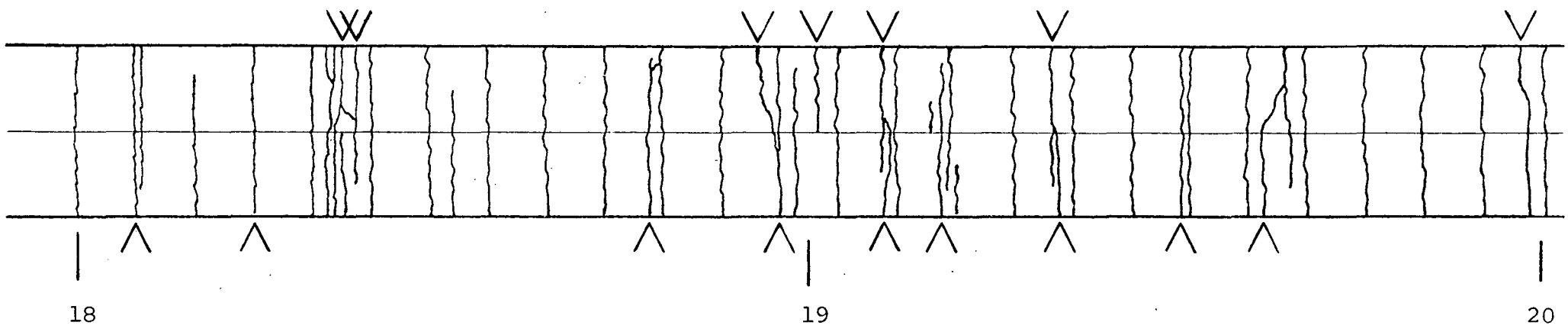

Section 5
Reflected Crack \wedge

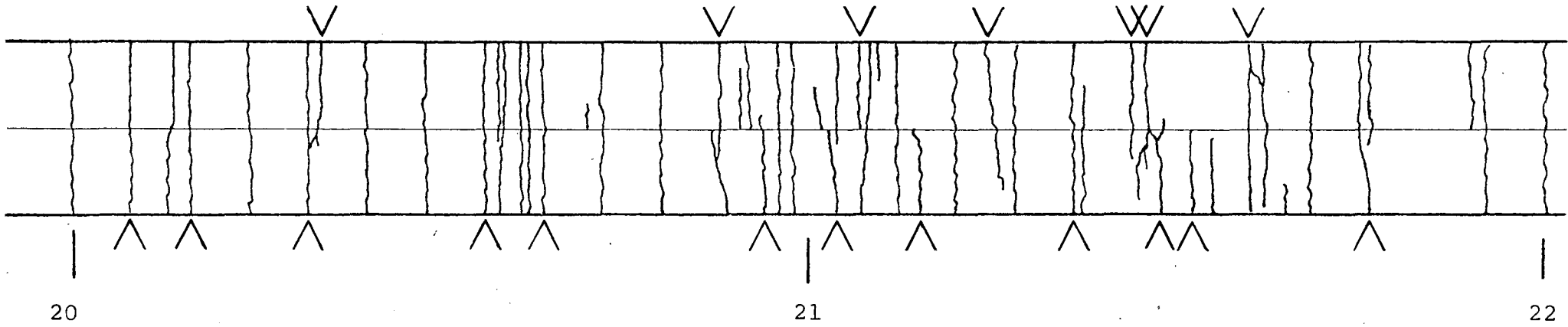



Section 5
Reflected Crack ^

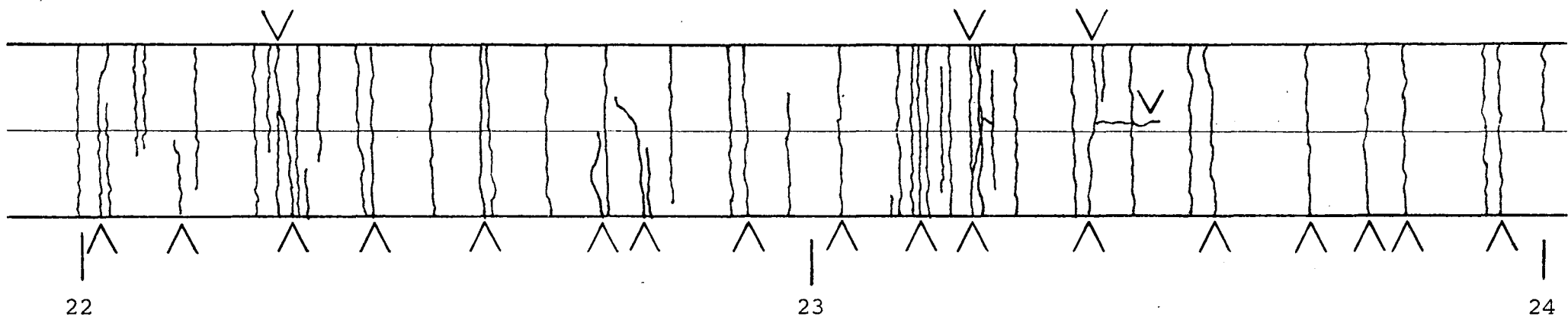

22

23

24



24 + 00

Section 6
(CRC Anchor)
Reflected Crack ^

Pavement - A-4
Bond - Bonded
Cement - 569 lb.
Thickness - 3"

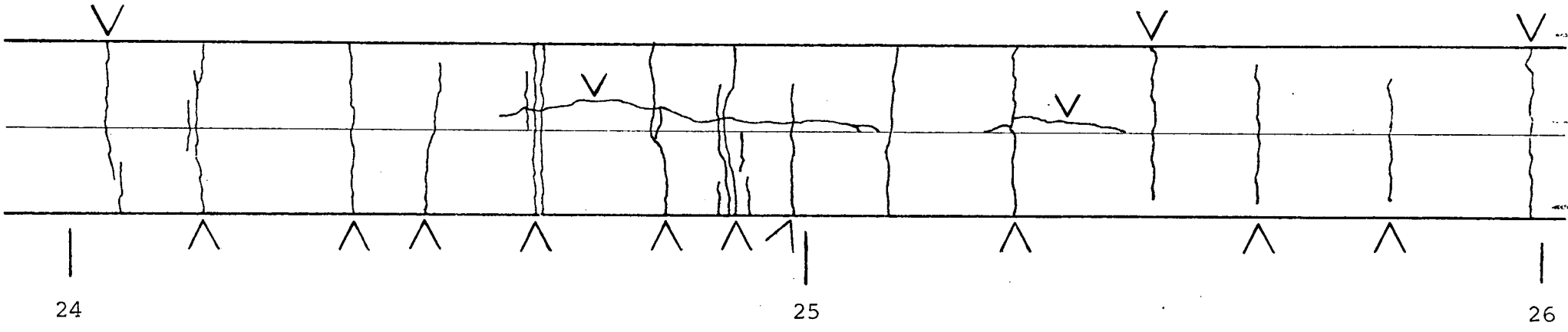
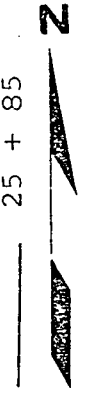

24

25

26



26 + 58

Transition

Section 7
(Fibrous)
Reflected Crack ^

Bond - Partial
Cement - 600 lb.
Fiber - 1", 60 lb.
Thickness - 3"

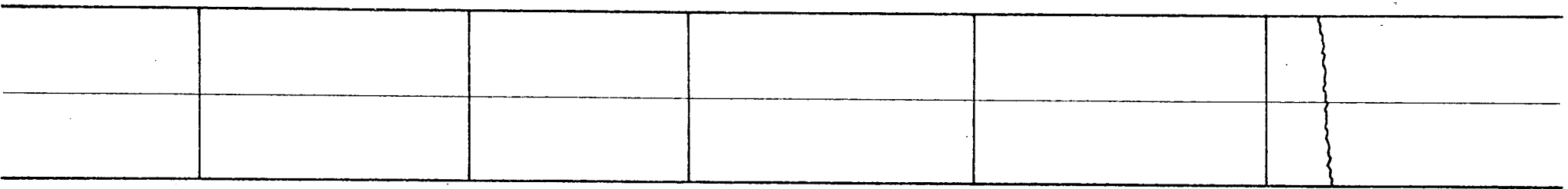

26

27

28



Section 7
Reflected Crack ^

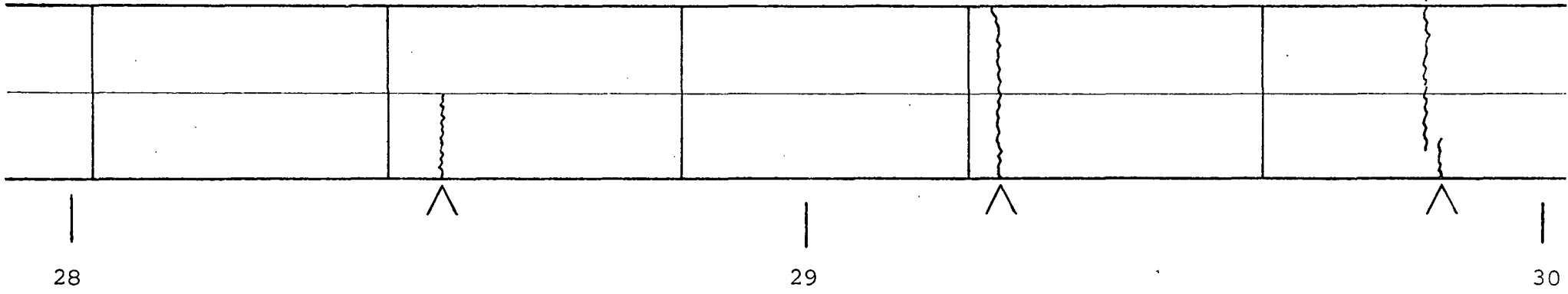

Section 7
Reflected Crack 

31 + 61

Transition

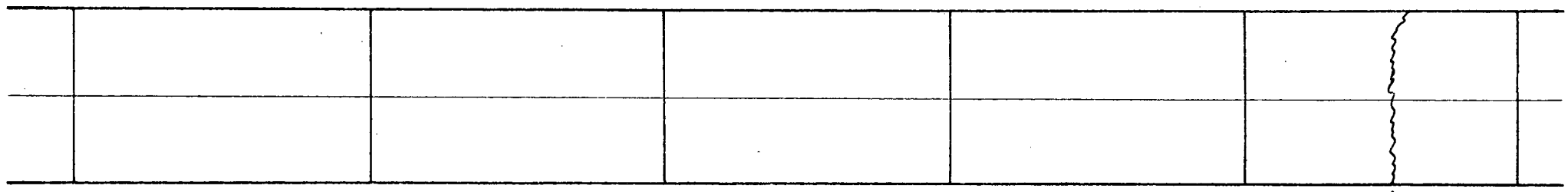

30

31

32

32 + 16

Section 8
(Fibrous)
Reflected Crack 

Bond - Partial
Cement - 750 lb.
Fiber - 2½", 60 lb.
Thickness - 3"

33 + 57

Transition

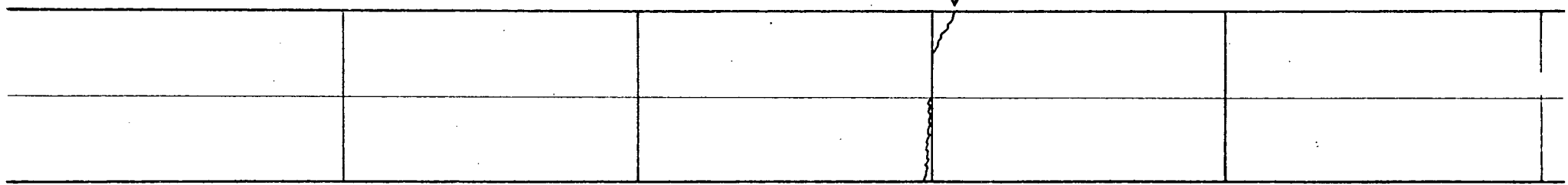

32

33

34



34 + 28

Section 9
(Fibrous)
Reflected Crack ^

Bond - Partial
Cement - 600 lb.
Fiber - 1", 100 lb.
Thickness - 3"

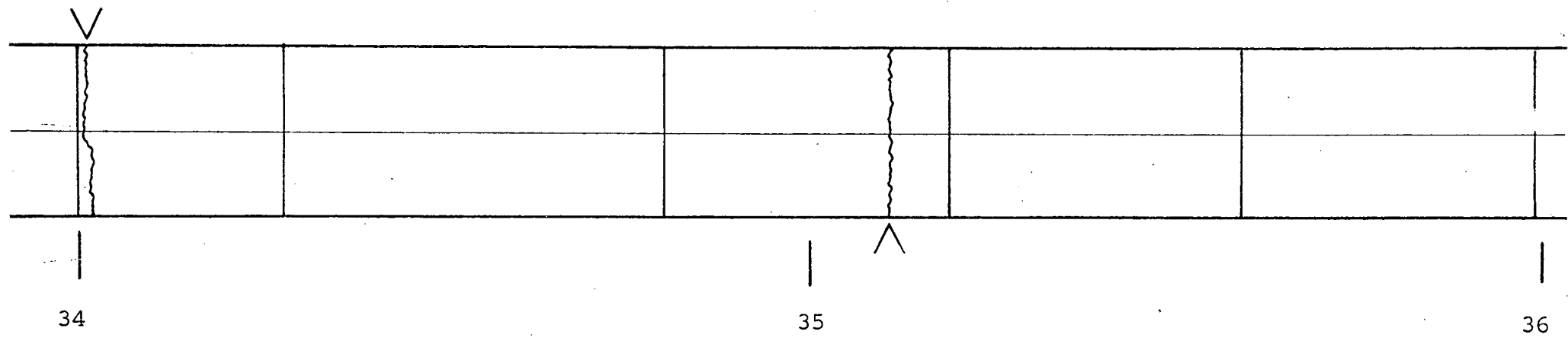

Section 9
Reflected Crack ^

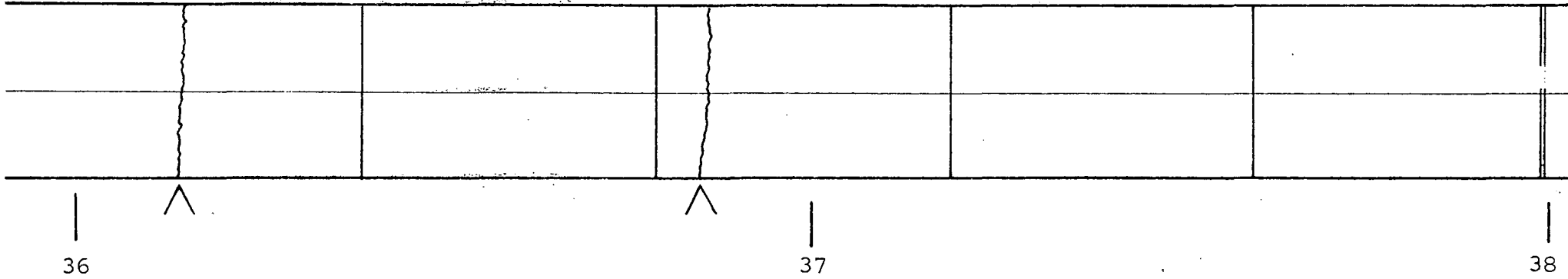

Expansion Joint



38 + 19

Transition

38 + 75

Section 10
(Fibrous)
Reflected Crack ^

Bond - Partial
Cement - 750 lb.
Fiber - 1", 100 lb.
Thickness - 3"

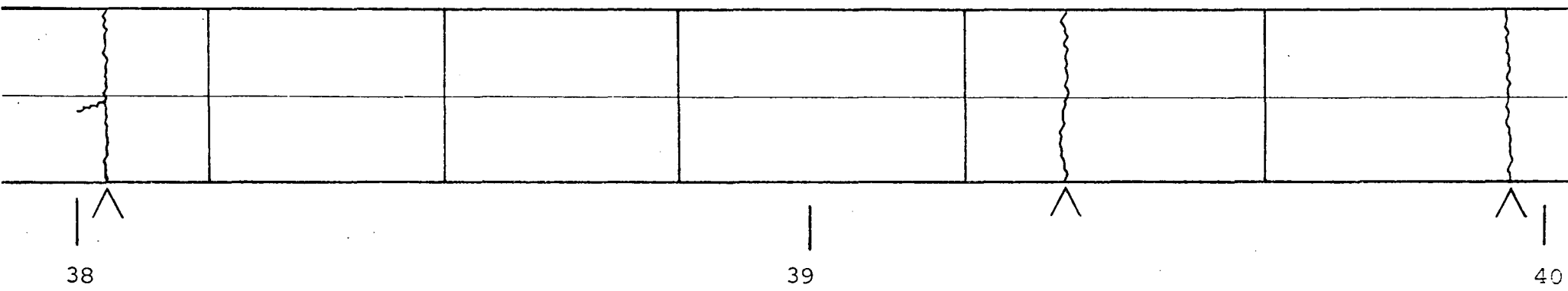

38

39

40

Section 10
Reflected Crack ^

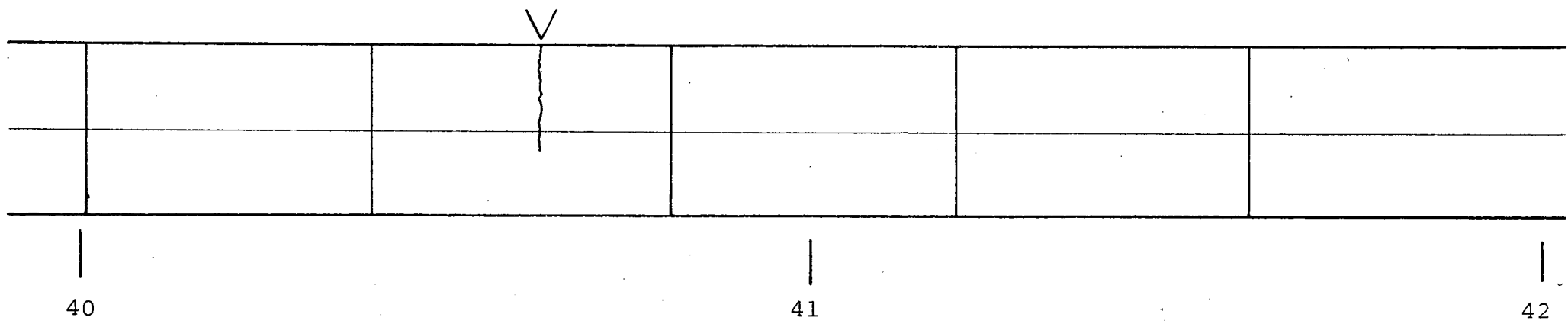



42 + 00

Section 11
(Fibrous)
Reflected Crack \wedge

Bond - Unbonded
Cement - 750 lb.
Fiber - 2½", 100 lb.
Thickness - 3"

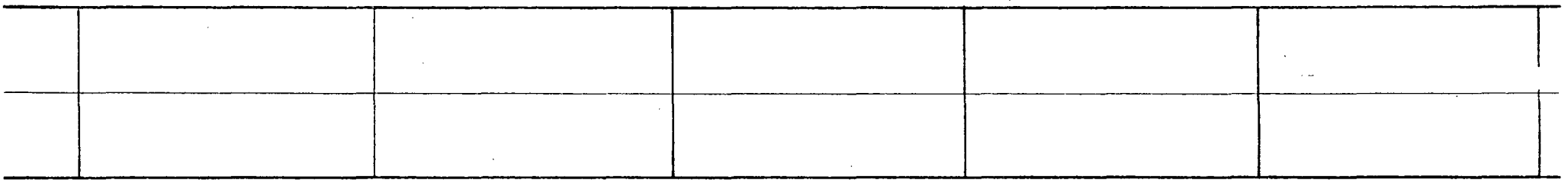

|

42

|

43

|

44



Section 11
Reflected Crack ^

45 + 60

Transition

N

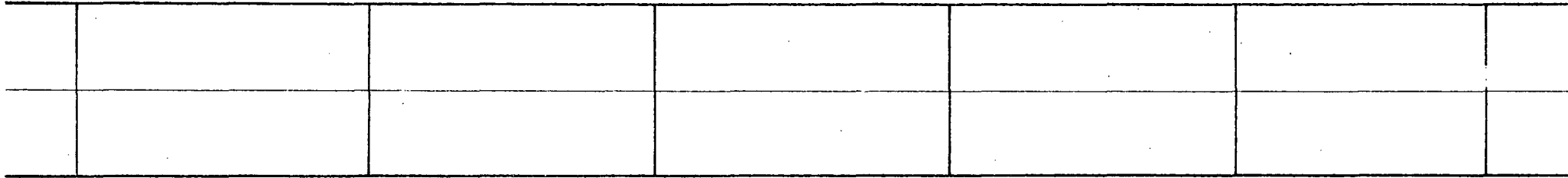

44

45

46



46 + 04

Section 12
(Fibrous)
Reflected Crack ^

Bond - Bonded
Cement - 750 lb.
Fiber - 1", 100 lb.
Thickness - 3"

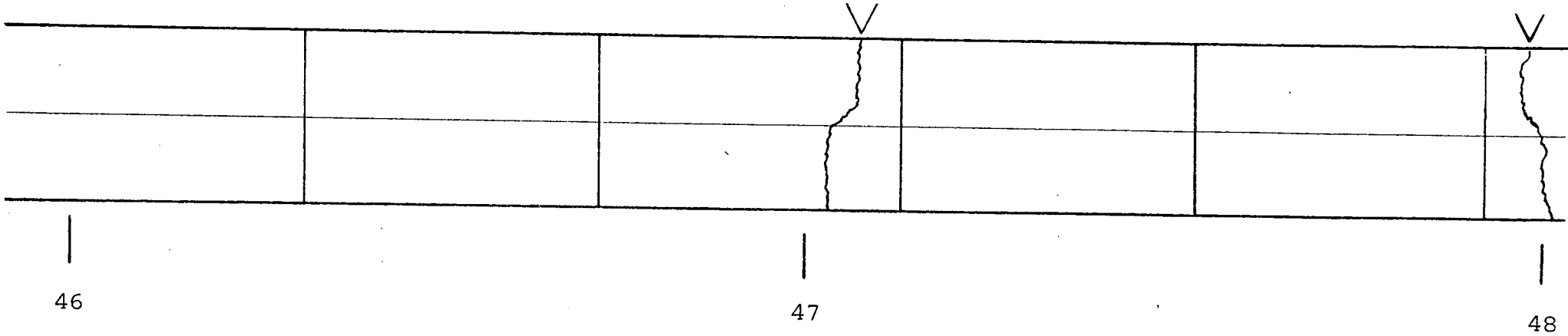

Section 12
Reflected Crack \wedge

49 + 52

Transition

N

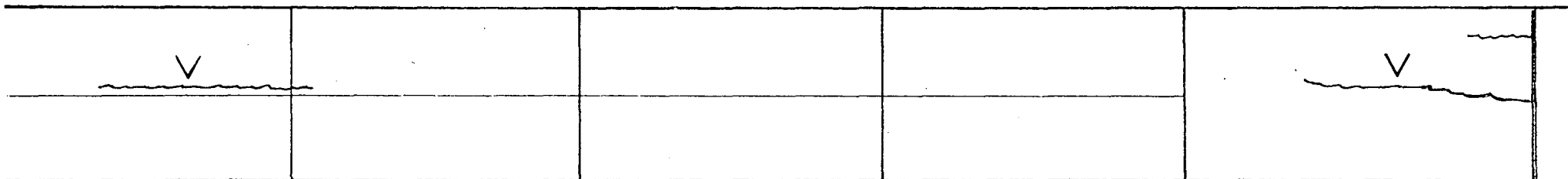

48

49

50

Expansion Joint

50 + 05

Section 13
(Fibrous)
Reflected Crack ^

Bond - Partial
Cement - 600 lb.
Fiber - 1", 60 lb.
Thickness - 3"

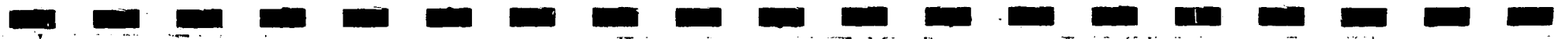
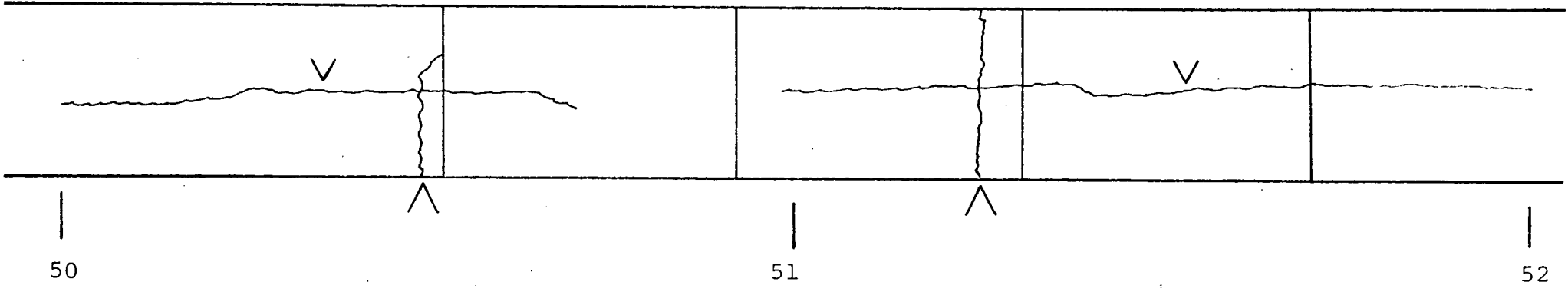

Section 13
Reflected Crack ^

53 + 70

Transition

N

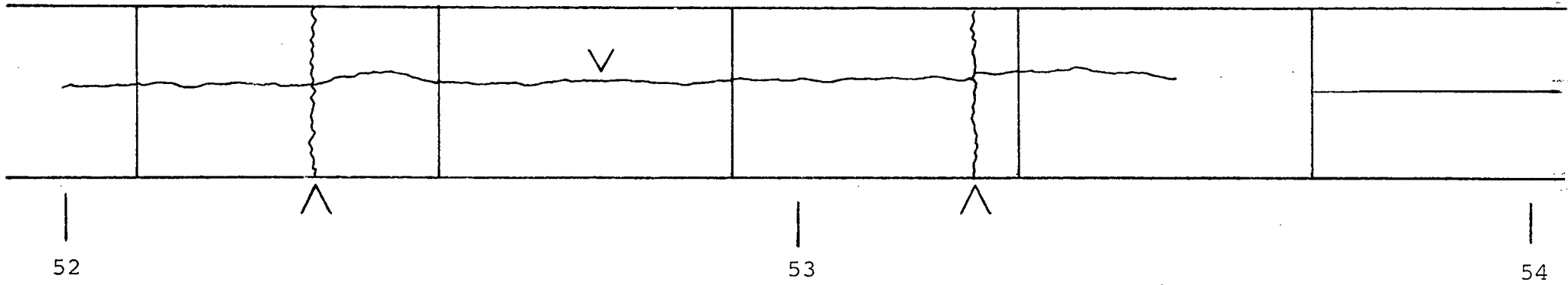



54 + 45

Section 14
(Fibrous)

Reflected Crack

Bond - Partial
Cement - 500 lb. + 234 lb. Fly Ash
Fiber - 1", 100 lb.
Thickness - 3"

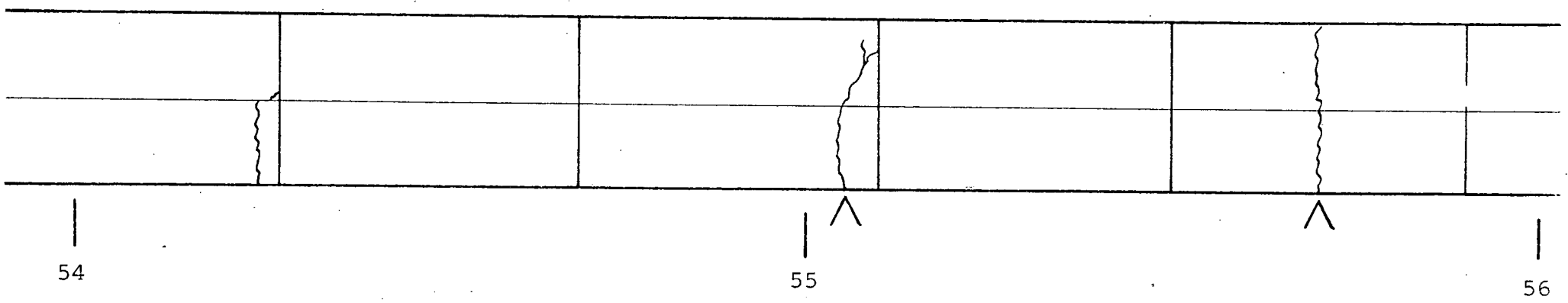

54

55

56

Section 14
Reflected Crack 

57 + 48

Transition

N

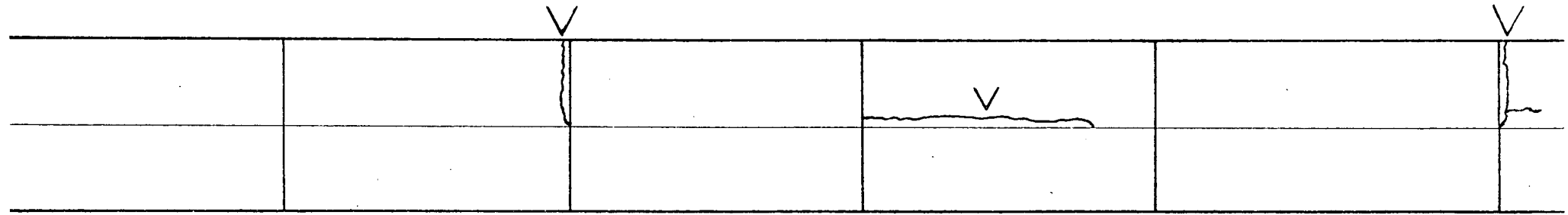

56

57

58



57 + 94

Section 15
(Fibrous)

Reflected Crack 

Bond - Partial
 Cement - 500 lb. + 234 lb. Fly Ash
 Fiber - 2 1/2", 100 lb.
 Thickness - 3"

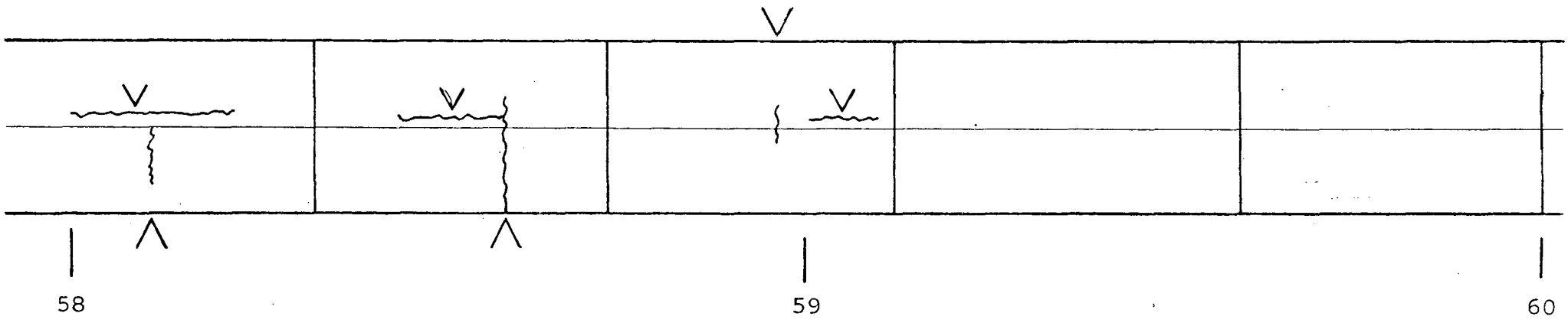

Section 15
Reflected Crack ^

61 + 64

Transition

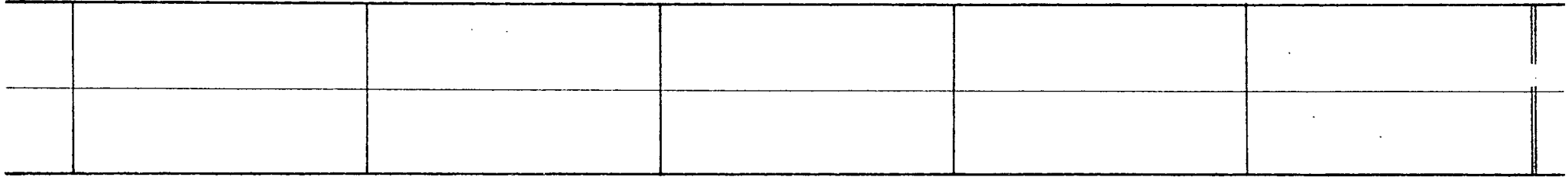

60

61

62

Expansion Joint



62 + 15

Section 16
(Fibrous)
Reflected Crack ^

Bond - Partial
Cement - 600 lb.
Fiber - 2 1/2", 60 lb.
Thickness - 3"

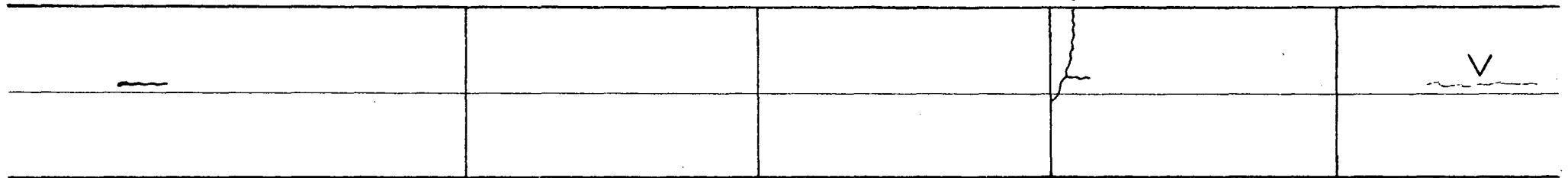

62

63

64



Section 16
Reflected Crack 

65 + 72

Transition 

N 

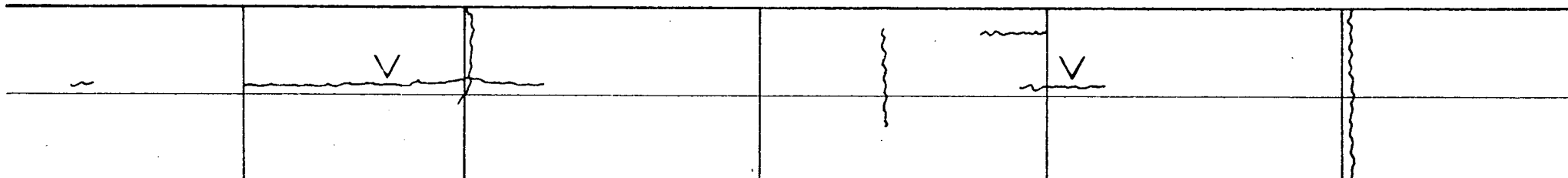

64

65

66



66 + 35

Section 17
(Fibrous)
Reflected Crack ^

Bond - Partial
Cement - 750 lb.
Fiber - 1", 60 lb.
Thickness - 3"

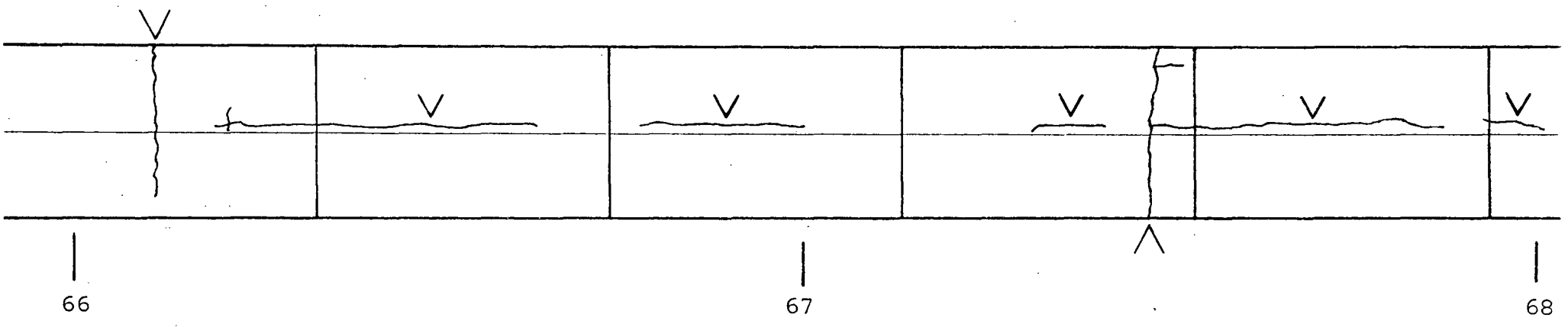

Section 17
Reflected Crack ^

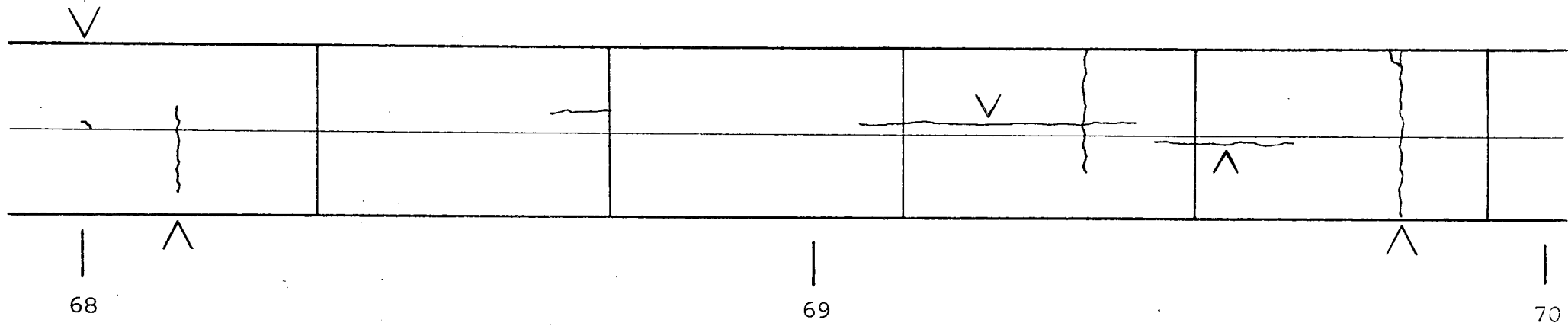



Section 18
(Fibrous)
Reflected Crack ^

Bond - Partial
Cement - 600 lb.
Fiber - 1", 160 lb.
Thickness - 3"

70

71

72



Section 18
Reflected Crack ^

N

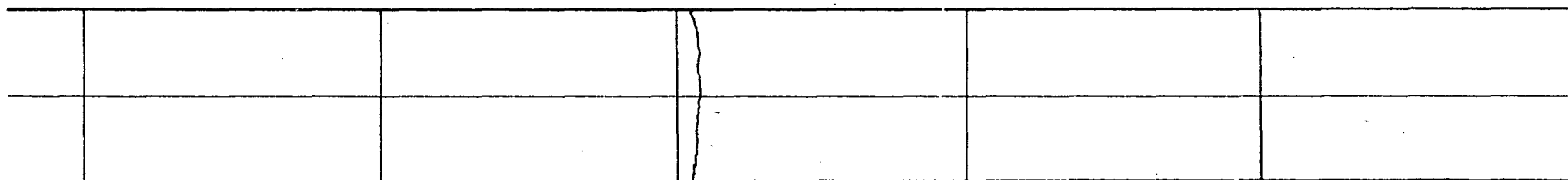

72

73

74



74 + 01

Section 19
(Fibrous)

Reflected Crack

Bond - Partial
Cement - 600 lb.
Fiber - 1", 160 lb.
Thickness - 3"

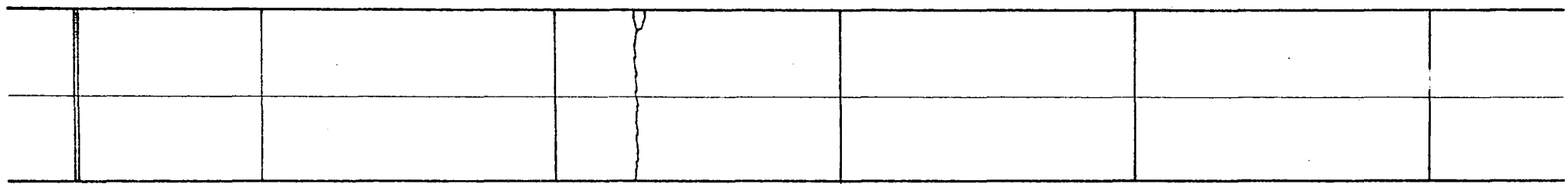

74

75

76



Section 19
Reflected Crack ^

77 + 44

Transition

77 + 84

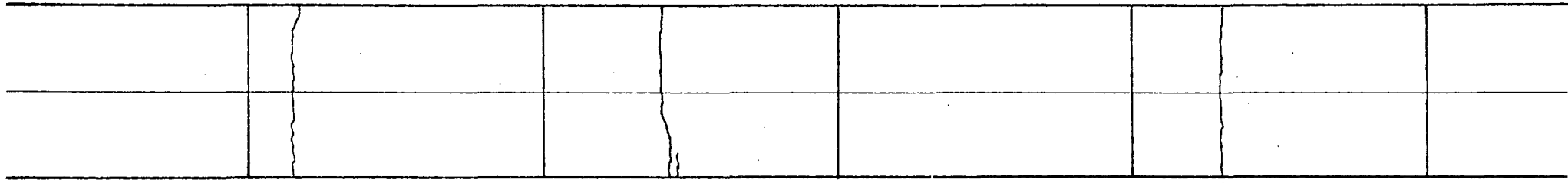

|

76

|

77



|

78



Section 20
(Fibrous)
Reflected Crack 

Bond - Unbonded
Cement - 750 lb.
Fiber - 1", 160 lb.
Thickness - 3"

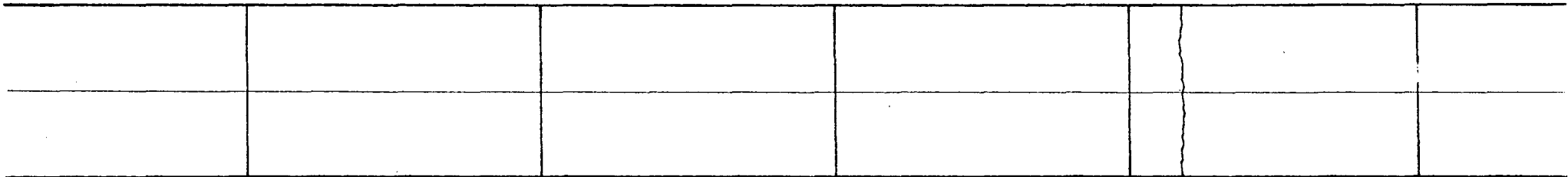

78

79



80



Section 20
Reflected Crack \wedge

81 + 44

Transition

N

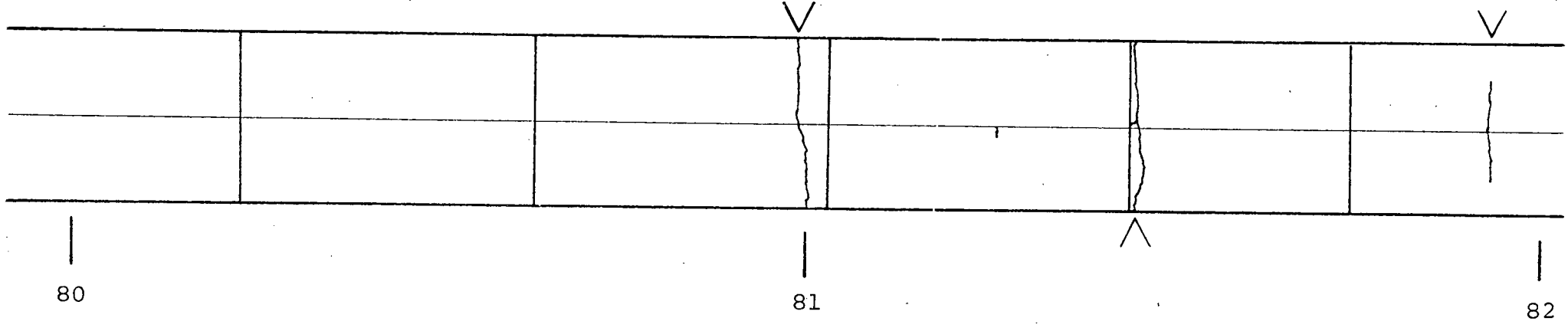

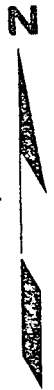



82 + 10

Section 21
(Fibrous)

Reflected Crack

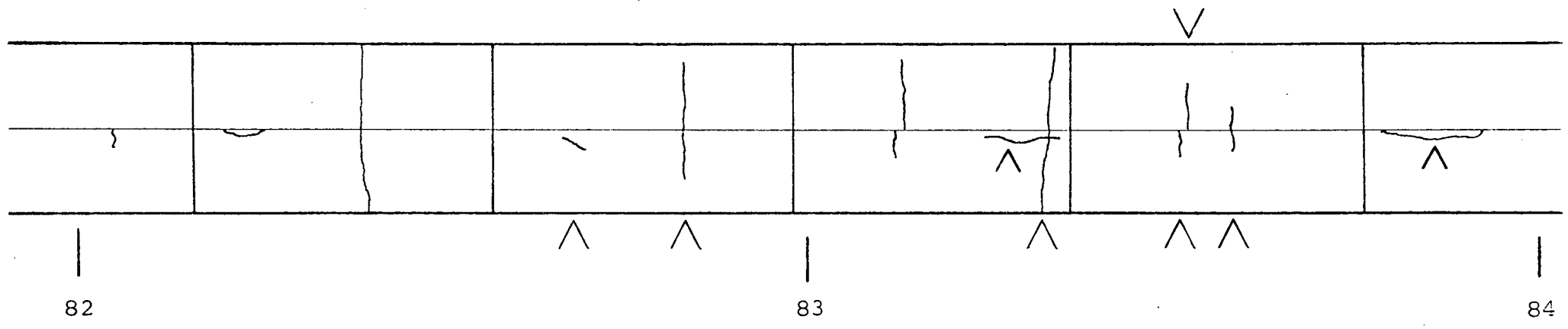
Bond	- Bonded
Cement	- 750 lb.
Fiber	- 2 1/2", 100 lb.
Thickness	- 3"



Section 21
Reflected Crack 

85 + 76

Transition

N

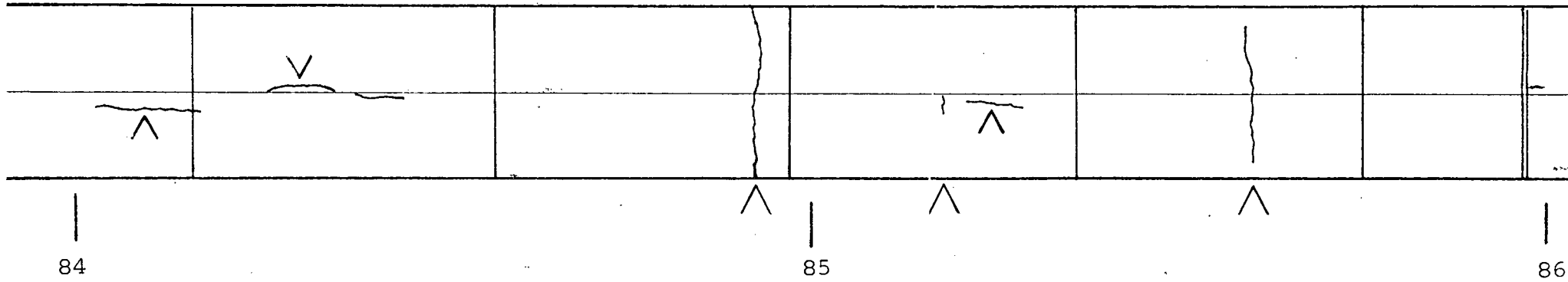

84

85

86



86 + 15
88

Section 22
(Fibrous)
Reflected Crack

Bond - On grade
Cement - 500 lb. + 234 lb. Fly Ash
Fiber - 1", 160 lb.
Thickness - 3"

|
86

|
87

|
88



Section 22

88 + 64

BRIDGE

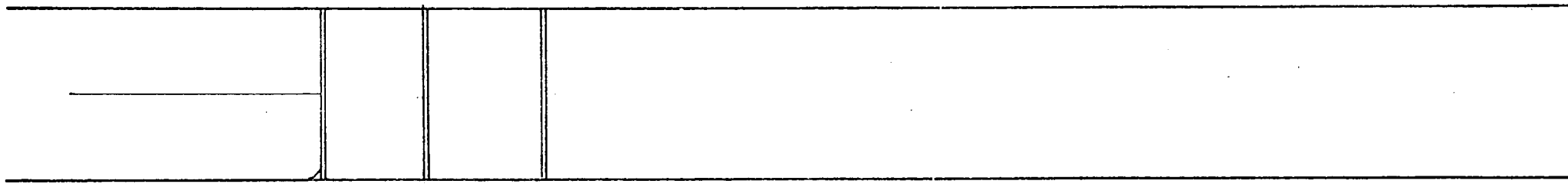

88



89



90



90 + 54

BRIDGE

Section 24
(Fibrous Curb Section)
Reflected Crack ^

Bond - Partial
Cement - 600 lb.
Fiber - 1", 100 lb.
Thickness - 3"

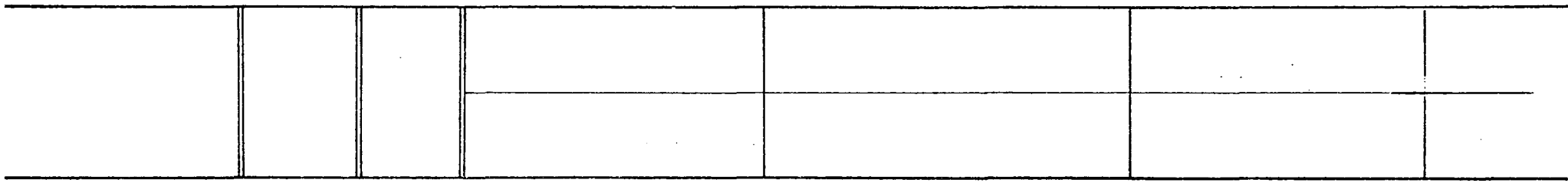

90

91

92



Section 24
Reflected Crack ^

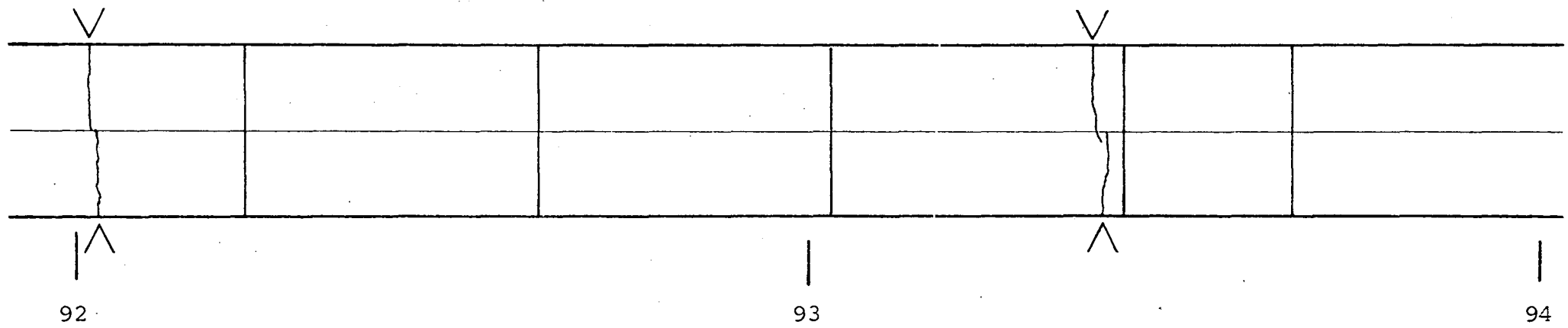

Section 24
Reflected Crack ^

95 + 63

Transition

95 + 85

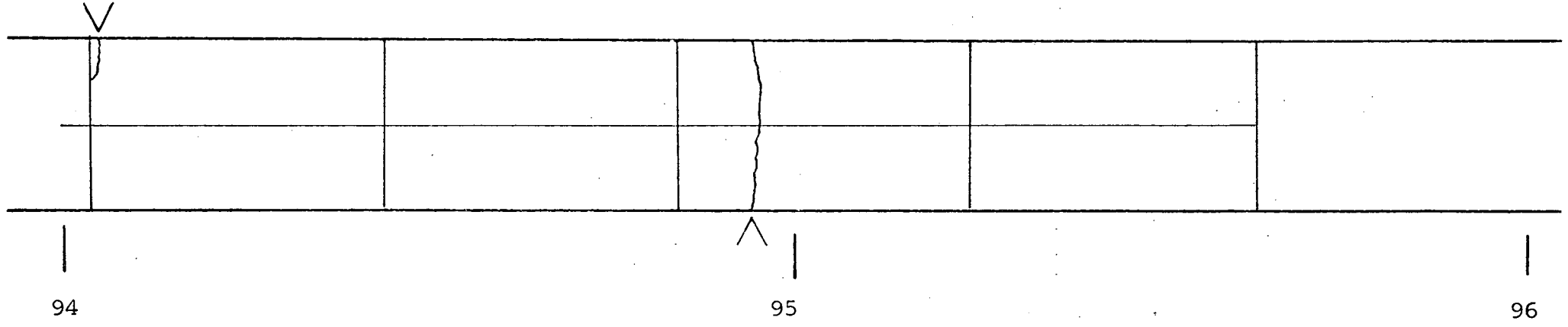

94

95

96

Section 25
(Fibrous)

Reflected Crack 

Bond - Unbonded
Cement - 750 lb. Chem. Comp.
Fiber - 2½", 100 lb.
Thickness - 3"

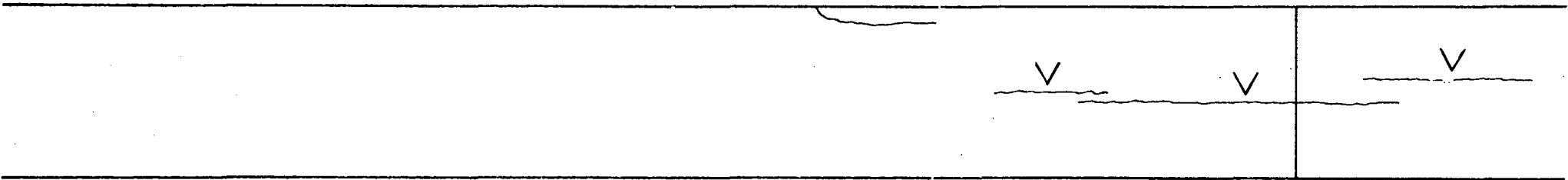

|
96

|
97

|
98

N



99 + 66

Transition

Section 25
Reflected Crack ^

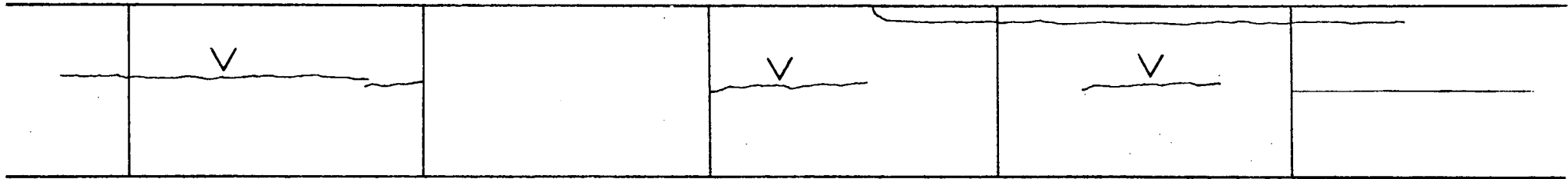

|

98

|

99

|

100

100 + 43

Section 26
(Fibrous)
Reflected Crack \wedge

Bond - Partial
Cement - 750 lb.
Fiber - 2 1/2", 160 lb.
Thickness - 2"

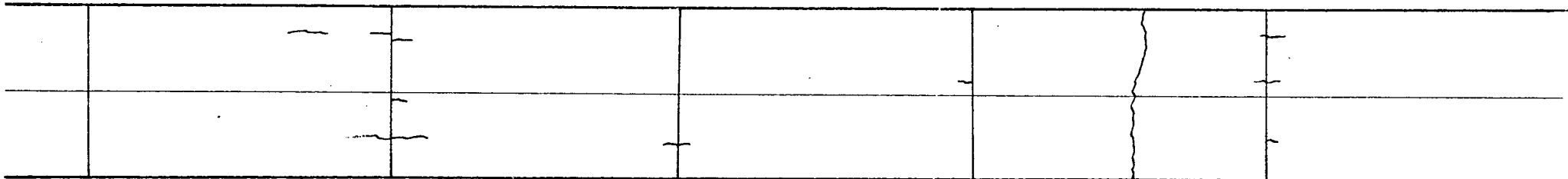

|

100

|

101



|

102



Section 26
Reflected Crack 

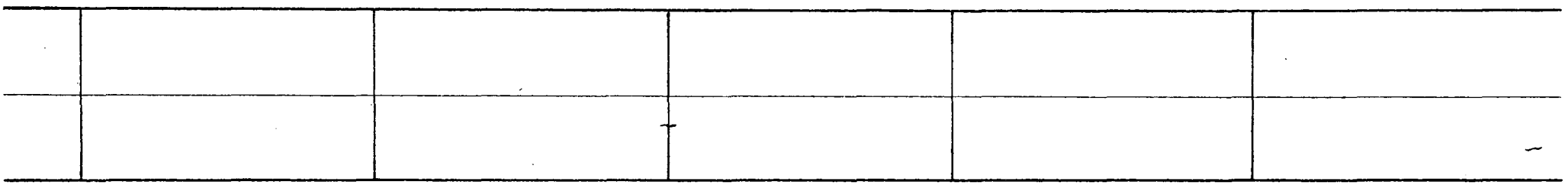

|
102

|
103

|
104



104 + 00

104 + 32

Transition

Section 27
(Fibrous)

Reflected Crack 

Bond - Partial
Cement - 600 lb.
Fiber - 1", 100 lb.
Thickness - 2"

N

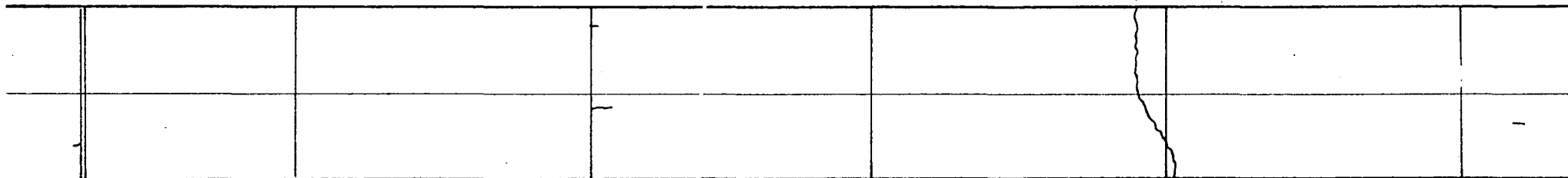

104

105

106

Section 27
Reflected Crack 

107 + 46

Transition

107 + 83

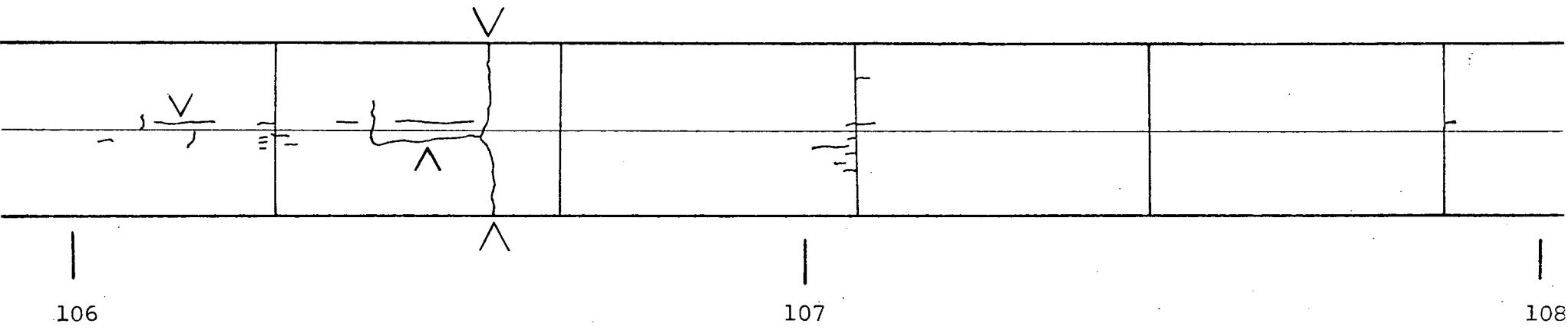

106

107

108

Section 28
(Fibrous)

Reflected Crack 

Bond - Partial
Cement - 750 lb.
Fiber - 1", 100 lb.
Thickness - 2"

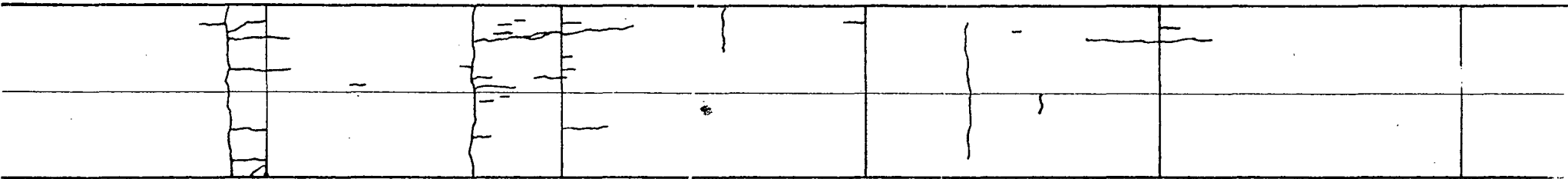

|
108

|
109

|
110

Section 28
Reflected Crack ^

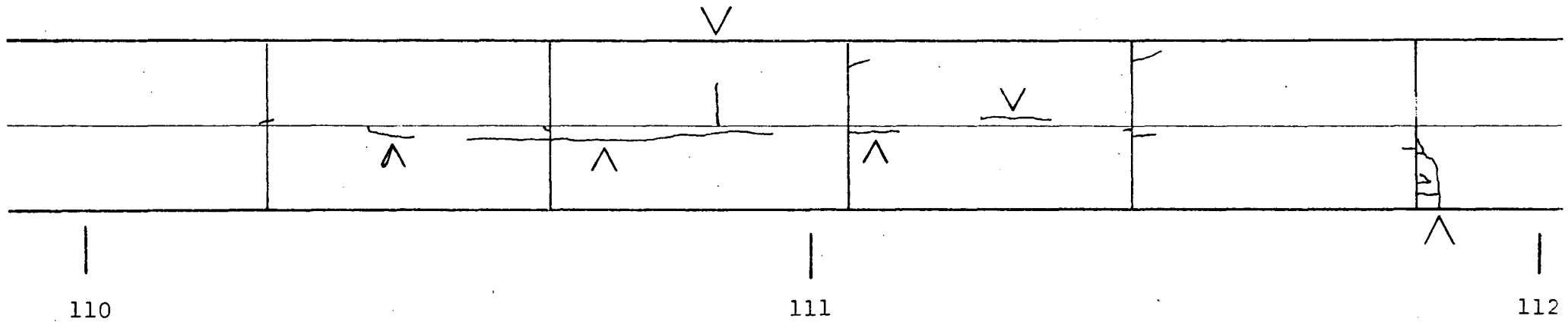

112 + 04

Section 29
(Fibrous)

Reflected Crack ^

Bond - Bonded
Cement - 750 lb.
Fiber - 1", 100 lb.
Thickness - 2"

N

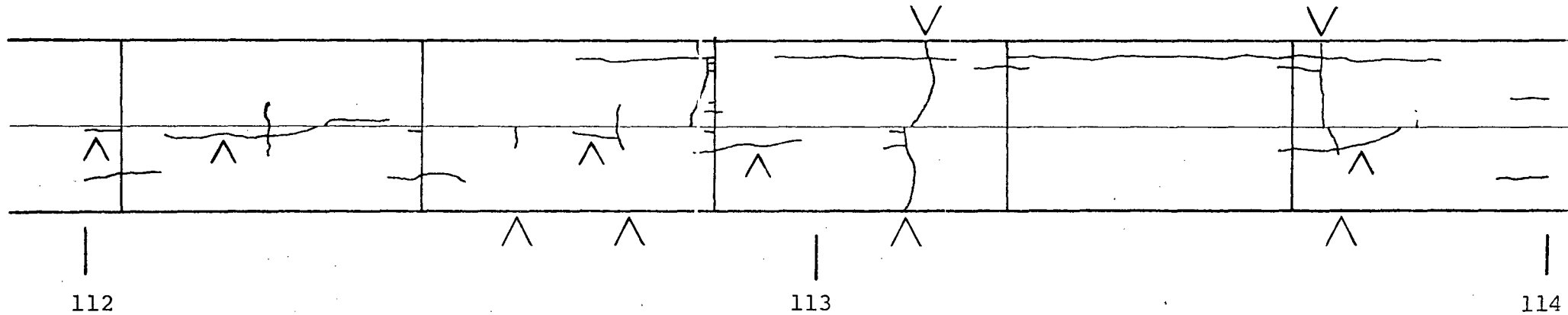

112

113

114



Section 29
Reflected Crack ^

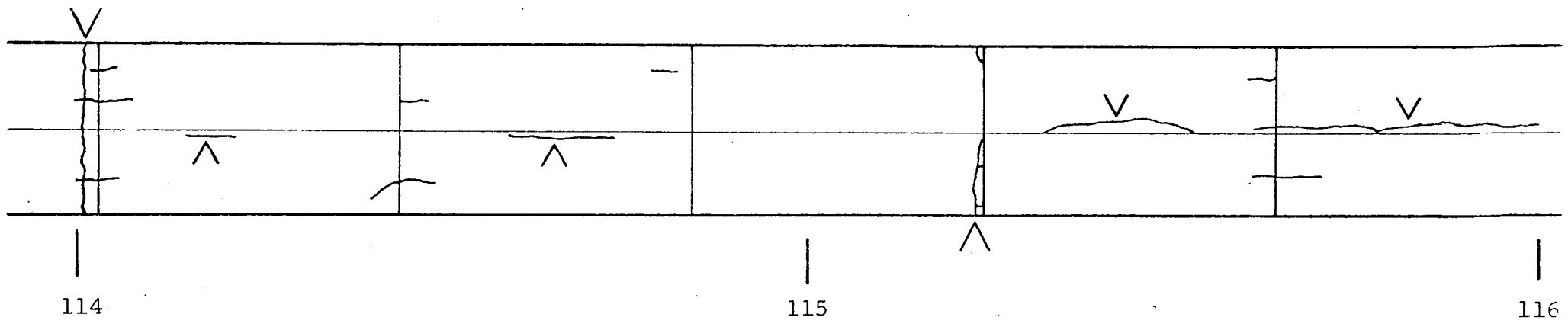

116 + 00

Section 30
(Fibrous)
Reflected Crack ^

Bond - Partial
Cement - 750 lb.
Fiber - 1", 160 lb.
Thickness - 2"

N

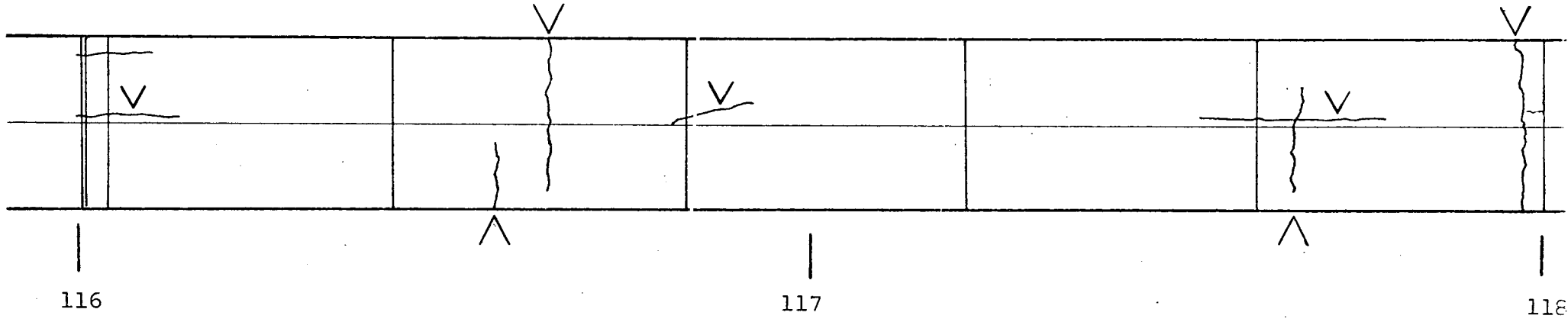

Section 30
Reflected Crack ^

119 + 50

Transition

N

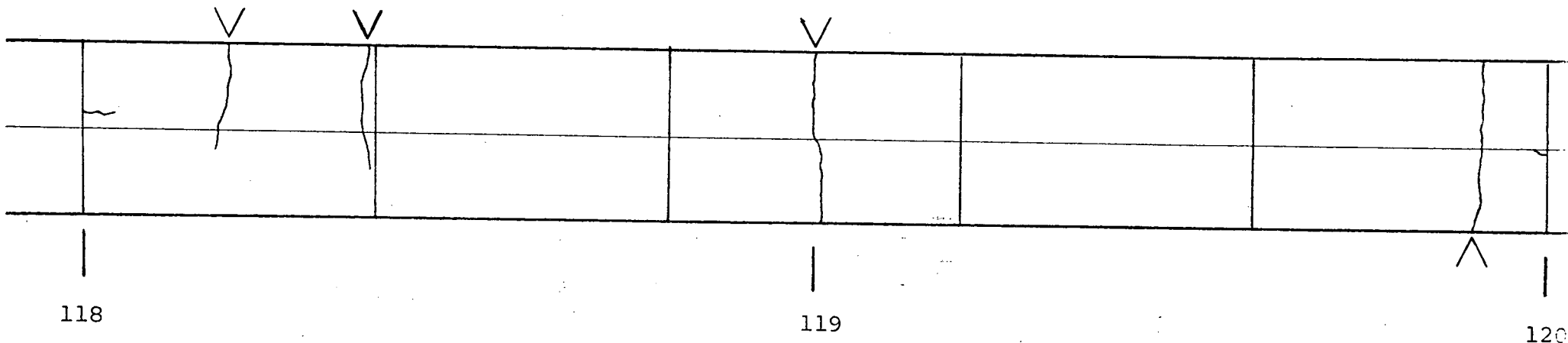

120 + 00

Section 31
(Fibrous)

Reflected Crack 

Bond - Partial
Cement - 600 lb.
Fiber - 1", 100 lb.
Thickness - 2"

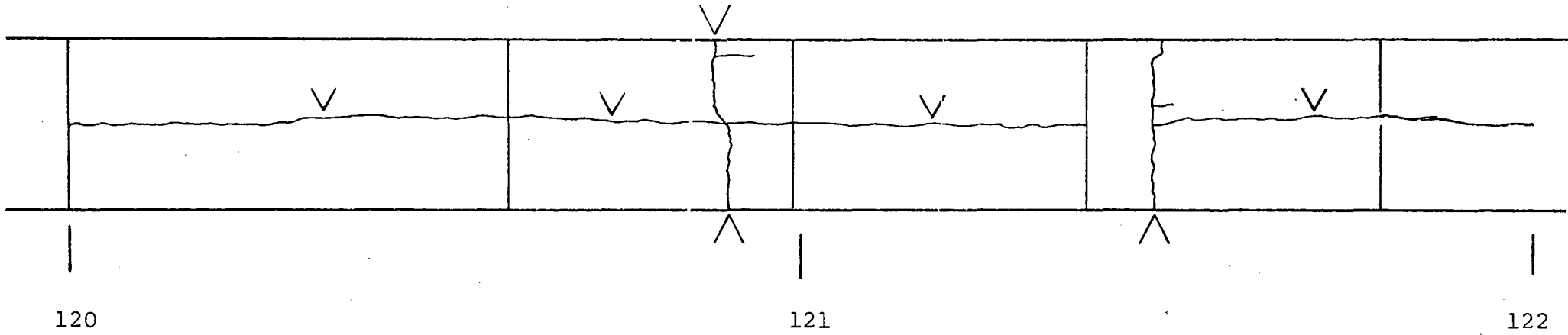



Section 31
Reflected Crack ^

123 + 00

Transition

123 + 41

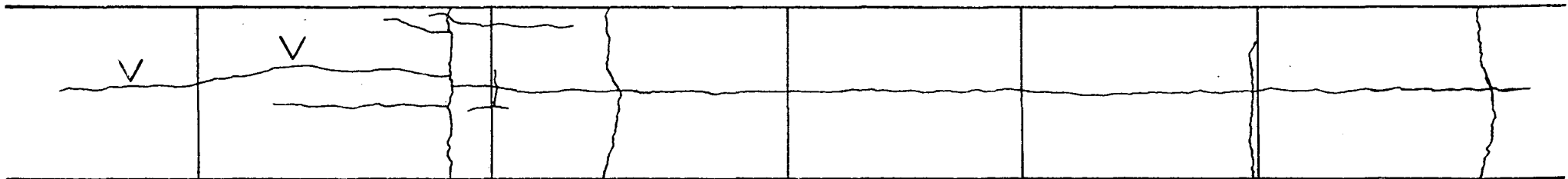

122

123

124



Section 32
(Fibrous)

Reflected Crack \wedge

Bond - Partial
Cement - 750 lb.
Fiber - 1", 100 lb.
Thickness - 2"

N

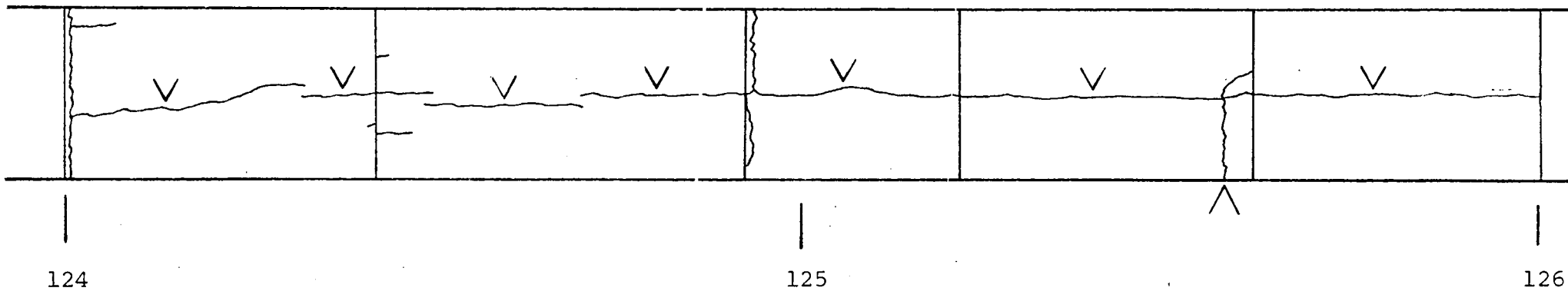

Section 32
Reflected Crack ^

127 + 58

Transition



127 + 99

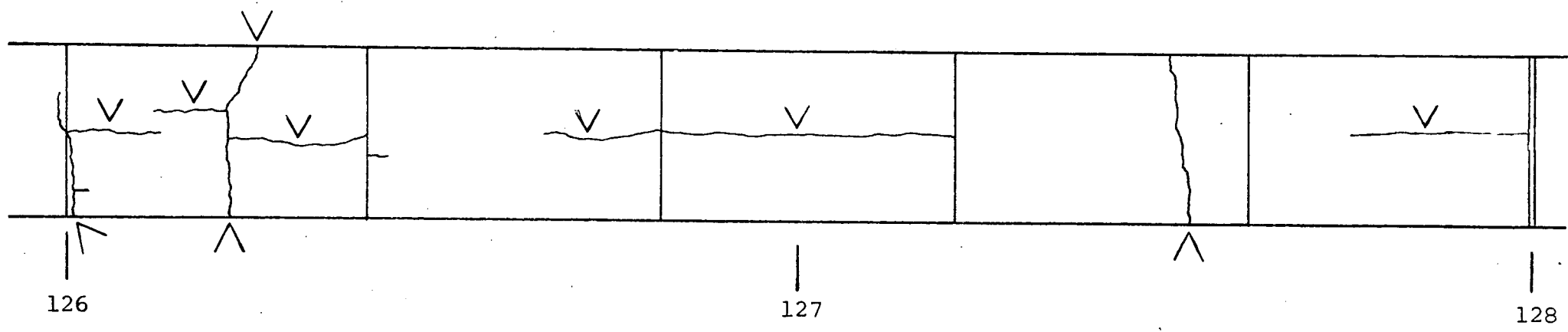

126

127

128

Section 33
(Fibrous)

Reflected Crack 

Bond - Partial
Cement - 600 lb.
Fiber - 1", 160 lb.
Thickness - 2"

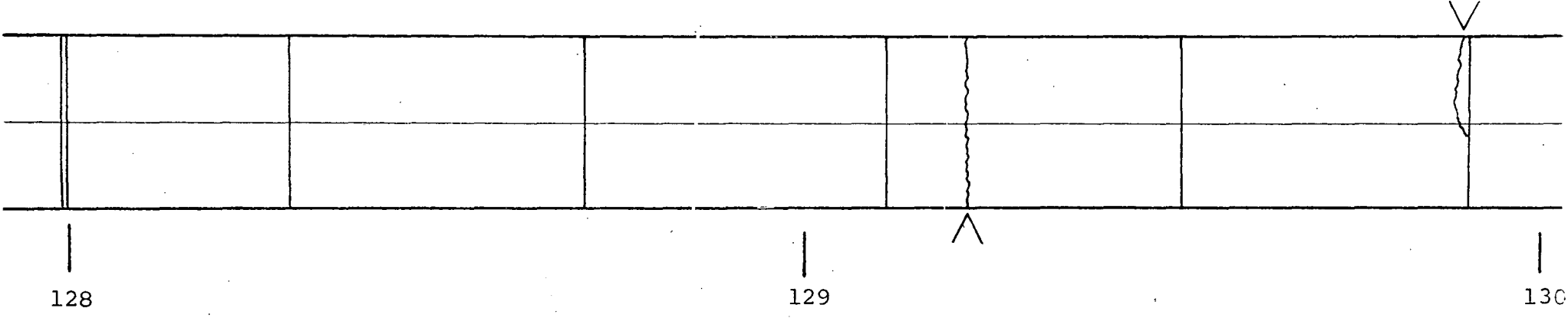

Section 33
Reflected Crack ^

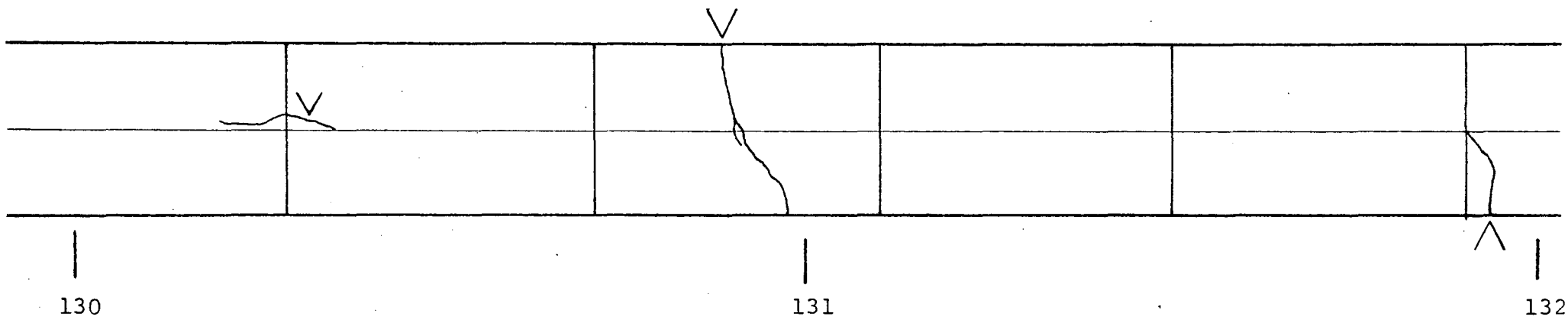
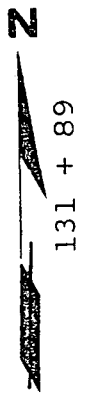

Transition

132 + 22

Section 34
(Fibrous)

Reflected Crack 

Bond - Partial
Cement - 750 lb.
Fiber - 1", 160 lb.
Thickness - 2"

N

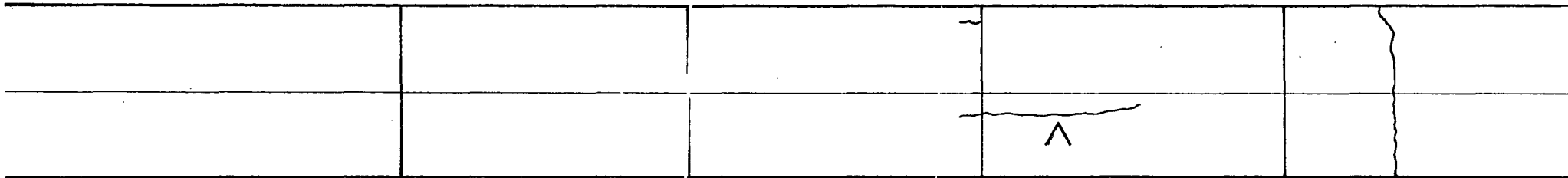

132

133

134

N



Section 34
Reflected Crack ^

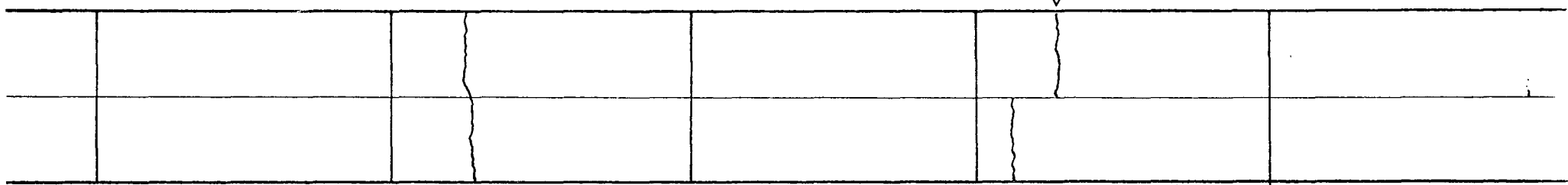

134



135

136

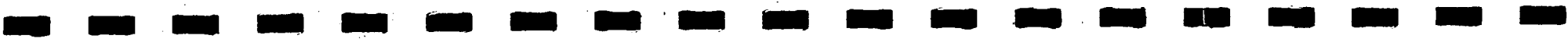

136 + 00

136 + 65

Transition

Section 35
(Fibrous)

Reflected Crack \wedge

Bond	- Unbonded
Cement	- 750 lb.
Fiber	- 2 1/2", 100 lb.
Thickness	- 2"

N

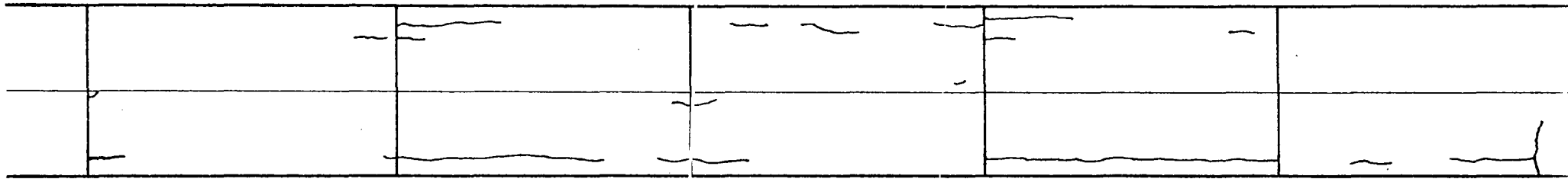

136

137

138

N



Section 35
Reflected Crack ^

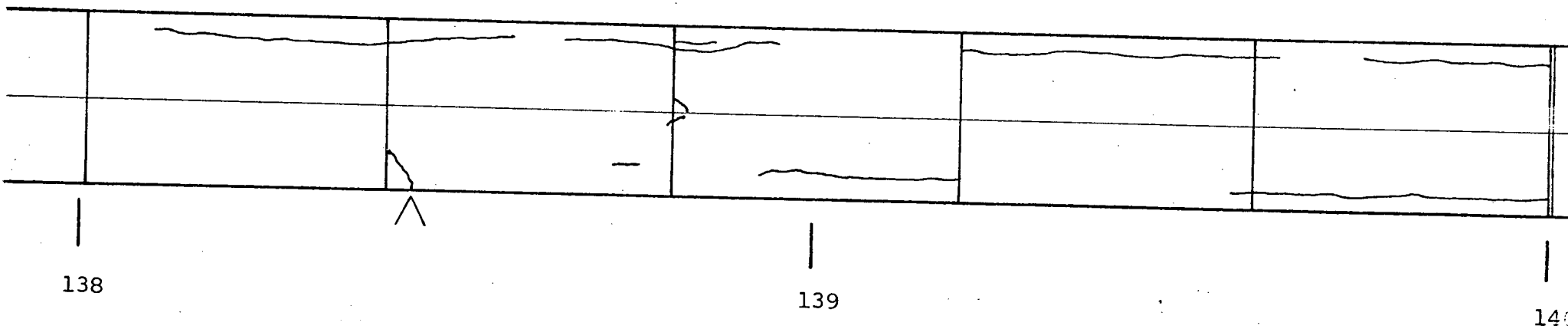

140 + 00

Section 36
(Fibrous)

Reflected Crack 

Bond - Bonded
Cement - 750 lb.
Fiber - 2 1/2", 100 lb.
Thickness - 2"

N

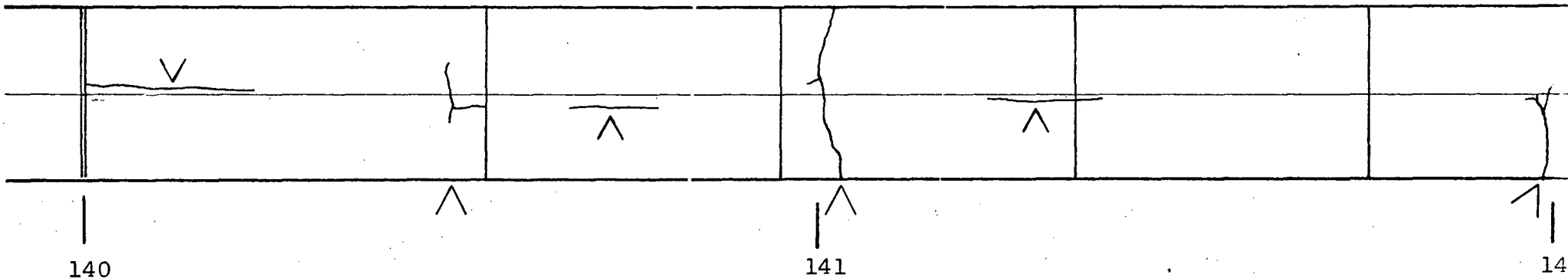

140

141

14

Section 36
Reflected Crack \wedge

143 + 74

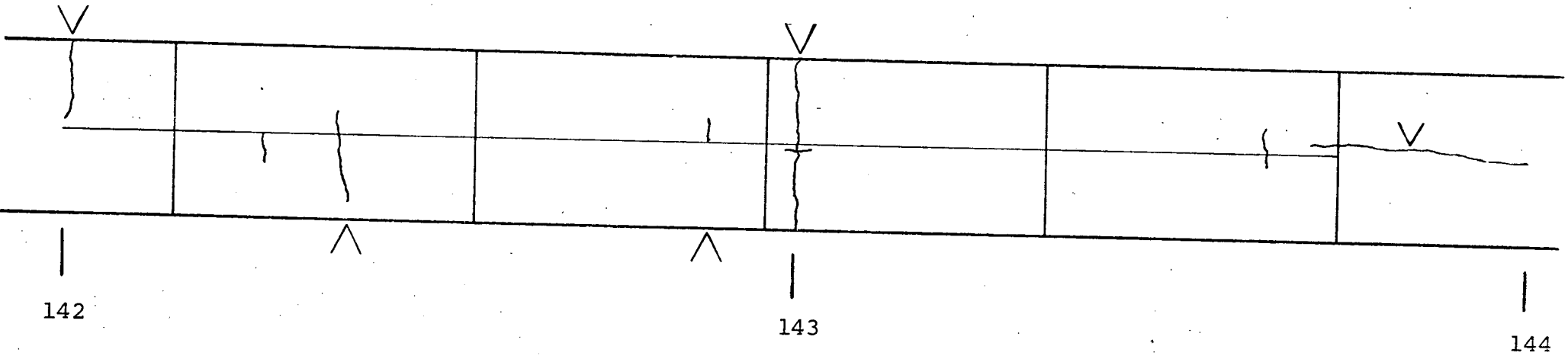

142

143

144

144 + 17

Transition

Section 37
(Fibrous)

Reflected Crack 

Bond - Partial
Cement - 600 lb.
Fiber - 2 1/2", 60 lb.
Thickness - 3"

N

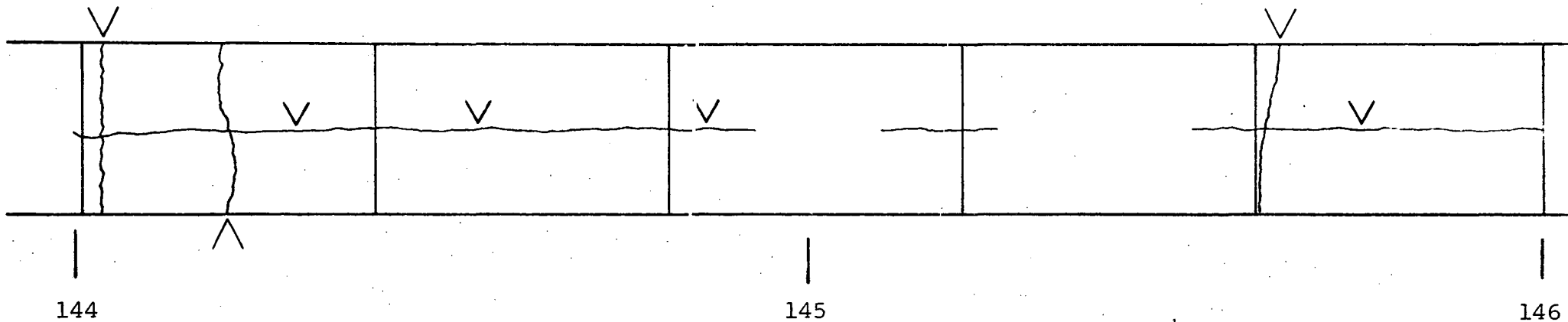

144

145

146

Section 37
Reflected Crack 

147 + 21

Transition

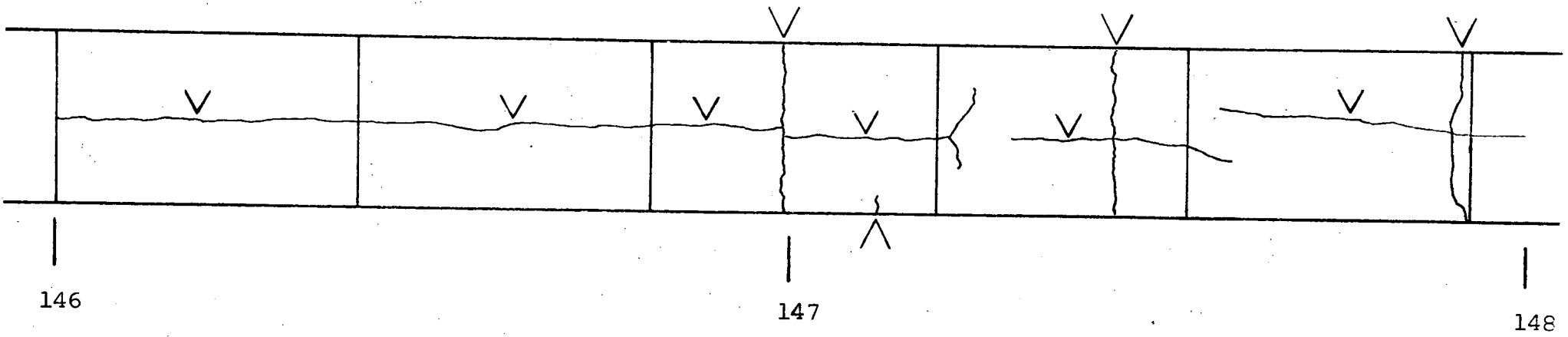

146

147

148

Section 38
(Mesh)

Reflected Crack 

Pavement - A-4
Bond - Partial
Cement - 569 lb.
Thickness - 4"

N

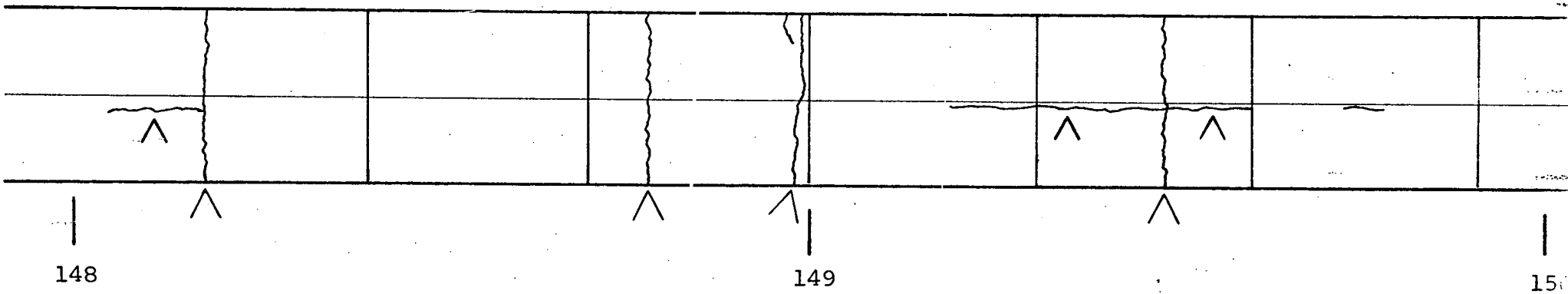

148

149

150

Section 38
Reflected Crack ^

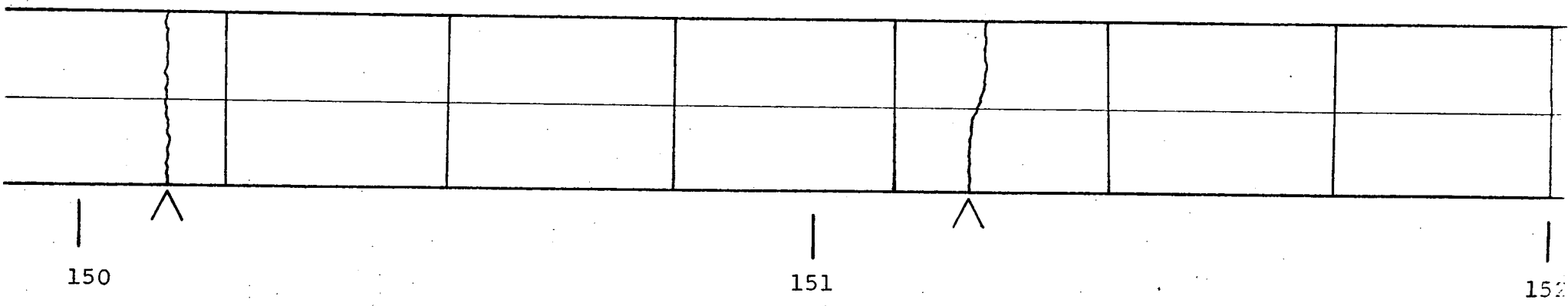

152 + 50

Section 39
Reflected Crack/\

Pavement - A-4
Bond - Partial
Cement - 569 lb.
Thickness - 5"

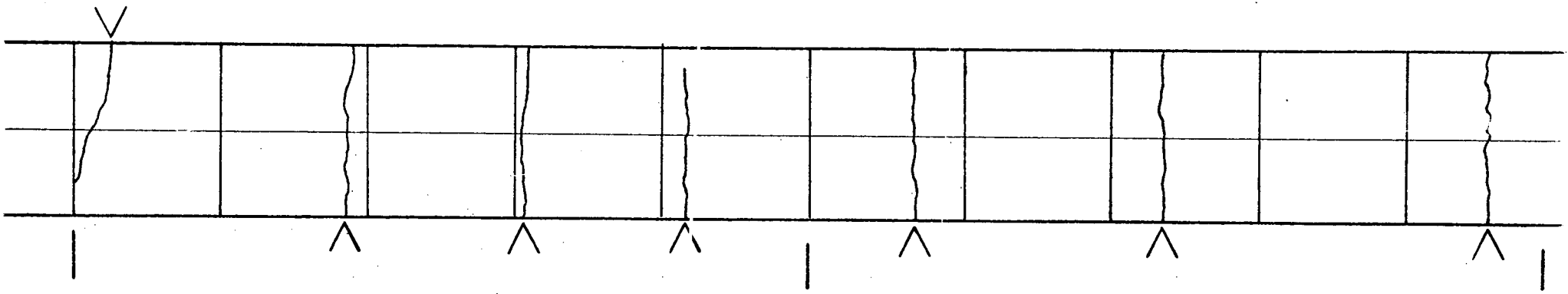

152

153

154

Section 40
(Fibrous)

Reflected Crack 

Bond - Partial
Cement - 500 lb. + 234 lb. Fly Ash
Fiber - 1", 100 lb.
Thickness - 3"

N

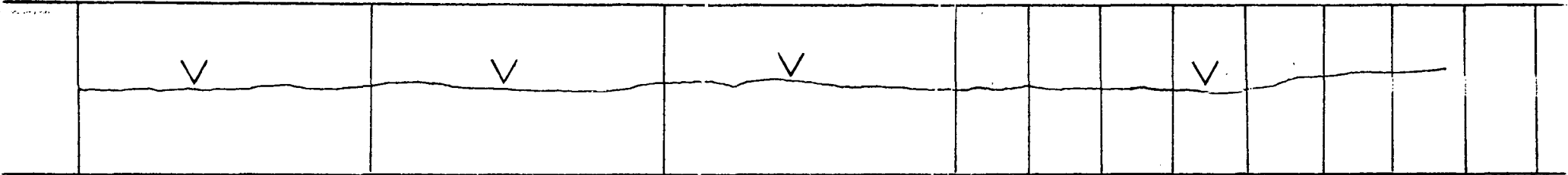

156

157

158



158 + 00

Section 40A
(Fibrous)

Bond - On grade
Cement - 500 lb. + 234 lb. Fly Ash
Fiber - 1", 160 lb.
Thickness - 3"

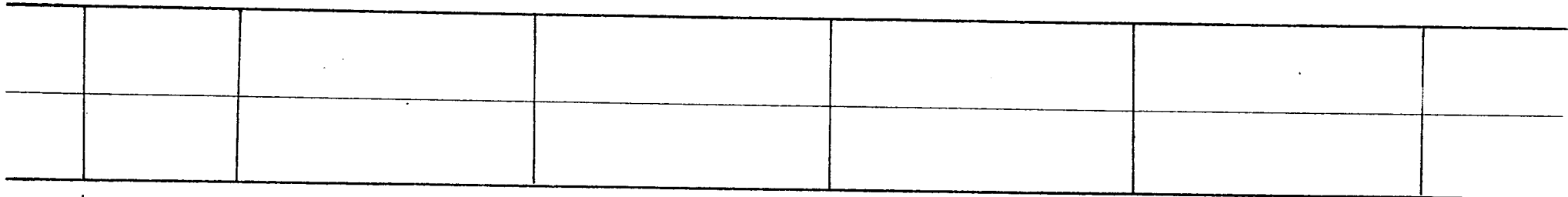

158

159

160



160 + 12



N



Old Pavement

160

End of Project

IOWA STATE HIGHWAY COMMISSION
Research Department

Research Project HR-165
Fibrous Concrete, Greene County

SUMMARY
6-28-74

Section No.	Station Begin	Numbers* End	Cement (lbs.)	Fiber Content		Thickness (in.)	Bond	Joint Spacing (ft.)	CL Joint	Number Transverse Cracks	Number Reflected	Skid No.
				1"	2½"							
1	0 + 00	4 + 04	569	0	0	5	Partial	20	Yes	0	0	43
2	4 + 67	6 + 99	569	(Mesh)		4	Partial	30	Yes	17	16	45
3	6 + 99	10 + 98	569	(CRC Anchor)		4	Bonded	8	Yes	15	12	43
4	10 + 98	16 + 65	569	(CRC)		4	Unbond	8	Yes	125	30	44
5	17 + 16	24 + 00	569	(CRC)		3	Unbond	8	Yes	150	54	42
6	24 + 00	25 + 85	569	(CRC Anchor)		3	Bonded	8	Yes	21	12	38
7	26 + 58	31 + 61	600	60		3	Partial	40 FD	Yes	5	5	50
8	32 + 16	33 + 57	750		60	3	Partial	40	Yes	2	2	48
9	34 + 28	38 + 19	600	100		3	Partial	40 FD	Yes	4	4	47
10	38 + 75	42 + 00	750	100		3	Partial	40	Yes	3	3	44
11	42 + 00	45 + 60	750		100	3	Unbond	40	Yes	0	0	40
12	46 + 04	49 + 52	750	100		3	Bonded	40	Yes	2	2	43

*Variation in beginning station numbers due to transition sections.

Section No.	Station Begin	Numbers* End	Cement (lbs.)	Fiber Content		Thickness (in.)	Bond	Joint Spacing (ft.)	CL Joint	Number Transverse Cracks	Number Reflected	Skid No.
				1"	2½"							
13	50 + 05	53 + 70	600	60		3	Partial	40	No	4	4	44
14	54 + 45	57 + 48	500 + 234 FA	100		3	Partial	40	Yes	3	3	54
15	57 + 94	61 + 64	500 + 234 FA		100	3	Partial	40	Yes	3	3	54
16	62 + 15	65 + 72	600		60	3	Partial	40	Yes	3	1	45
17	66 + 35	69 + 92	750	60		3	Partial	40	Yes	4	3	32
18	69 + 92	74 + 01	600	160		3	Partial	40	Yes	1	1	47
19	74 + 01	77 + 44	600	160		3	Partial	40	Yes	4	1	46
20	77 + 84	81 + 44	750	160		3	Partial	40	Yes	2	2	41
21	82 + 10	85 + 76	750		100	3	Bonded	40	Yes	11	9	35
22	86 + 15	88 + 64	500 + 234 FA	160		3	On grade	40	Yes	0	0	52
23	88 + 64	90 + 54	750	160 (Bridge)		3	Bonded	0	No	0	0	52
24	90 + 54	95 + 63	600	100		3	Partial	40	Yes	6	6	46
25	95 + 85	99 + 66	750 CC		100	3	Unbond	40	No	0	0	32
26	100 + 43	104 + 00	750		160	2	Partial	40	Yes	1	1	42
27	104 + 32	107 + 46	600	100		2	Partial	40	Yes	6	4	44
28	107 + 83	111 + 85	750	100		2	Partial	40 FD	Yes	7	2	44

*Variation in beginning station numbers due to transition sections.

Section No.	Station Begin	Numbers* End	Cement (lbs.)	Fiber Content		Thickness (in.)	Bond	Joint Spacing (ft.)	CL Joint	Number Transverse Cracks	Numbers Reflected	Skid No.
				1'	2½"							
29	112 + 04	116 + 00	750	100		2	Bonded	40	Yes	12	8	48
30	116 + 00	119 + 50	750	160		2	Partial	40	Yes	8	7	41
31	120 + 00	123 + 00	600	100		2	Partial	40	No	5	4	44
32	123 + 14	127 + 58	750	100		2	Partial	40	No	12	6	40
33	127 + 99	131 + 89	600	160		2	Partial	40	Yes	3	3	46
34	132 + 22	136 + 00	750	160		2	Partial	40	Yes	4	2	42
35	136 + 65	140 + 00	750		100	2	Unbond	40	Yes	2	1	35
36	143 + 74	144 + 17	750		100	2	Bonded	0	Yes	9	7	41
37	144 + 17	147 + 21	600		60	2	Partial	40	No	4	4	46
38	147 + 92	151 + 84	569		(Mesh)	4	Partial	30	Yes	7	6	50
39	152 + 50	155 + 43	569		(None)	5	Partial	20	Yes	13	13	46
40	155 + 84	158 + 00	500 + 234 FA	100		3	Partial	Var.	No	0	0	50
40 A	158 + 00	160 + 21	500 + 234 FA	160		3	On grade	40	Yes	0	0	51

*Variation in beginning station numbers due to transition sections.