

A d d e n d u m

Iowa Department of Transportation
Office of Contracts

Date of Letting: August 21, 2012
Date of Addendum: August 16, 2012

B.O.	Proposal ID	Proposal Work Type	County	Project Number	Addendum
402	39-7457-604	Buildings - Renovation	Guthrie	STP-ES-7457(604)--8I-39	21aug402.a02

Notice: Only the bid proposal holders receive this addendum and responsibility for notifying any potential subcontractors or suppliers remains with the proposal holder.

Make the following change to the plan:

Delete Sheets E0.1 and E4.4 and replace with the attached Sheets E0.1 and E4.4.

Municipal Electric Utility Company will install pad mounted transformer and primary underground electrical service to pad mounted transformer.

Contractor shall install meter pedestal adjacent to pad mounted transformer and shall install underground secondary electrical service from pad mounted transformer to meter pedestal and to the panel board in the building.

Make the following change to the Plan Sheet B.2:

Under text in PAVER STONE, SAND SETTING BED, JOINT SAND, JOINT STABILIZER SPACER NOTES, paragraph 5. D. 1. Delete reference to a thickness of 2.76". The thickness of the pavers shall be 60mm/6cm.

Make the following change to the Special Provisions for Stuart Depot Community Building (SP-097044):

Section 08710 DOOR HARDWARE:

Delete the following items from Hardware group XO2A and X02N:

4041-PA LCN (Surface Closer)

220NA NGP (Door Sweep)

For door openings 101A, 101B, 108B and 112A provide four hinges in lieu of three as indicated in each doors respective hardware group. This impacts Hardware groups X02N, K02, X02A.

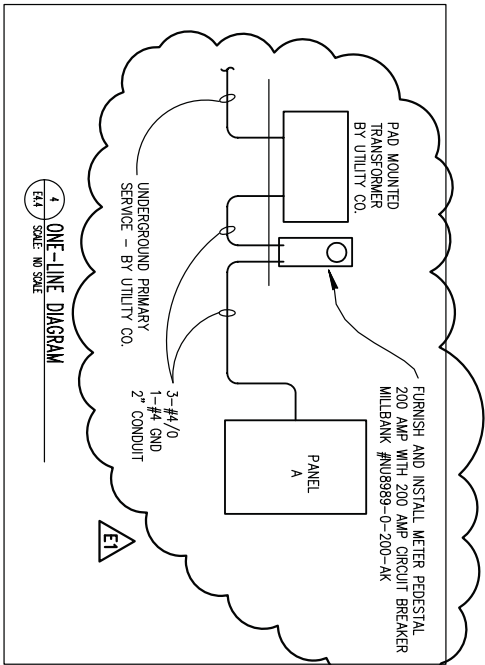
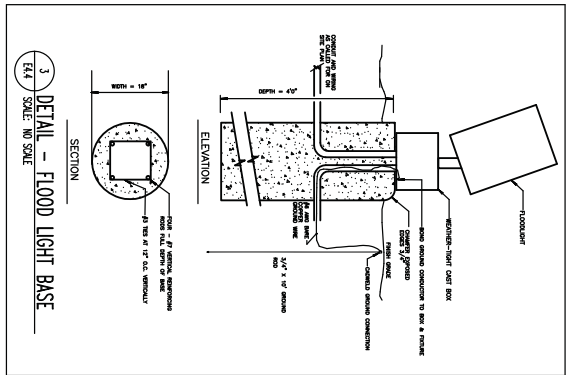
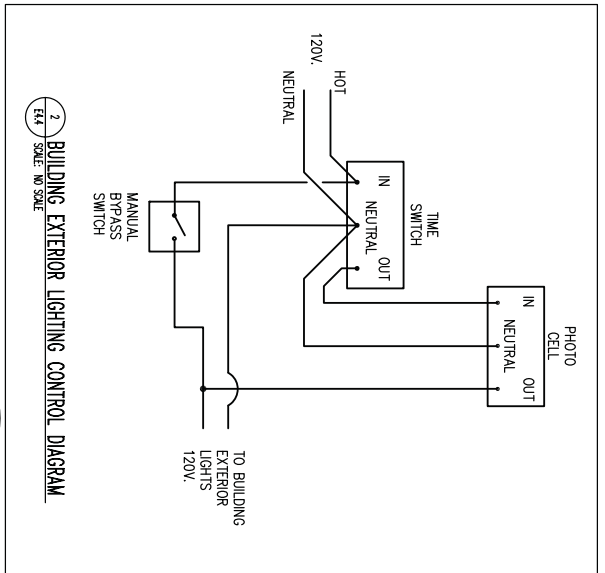
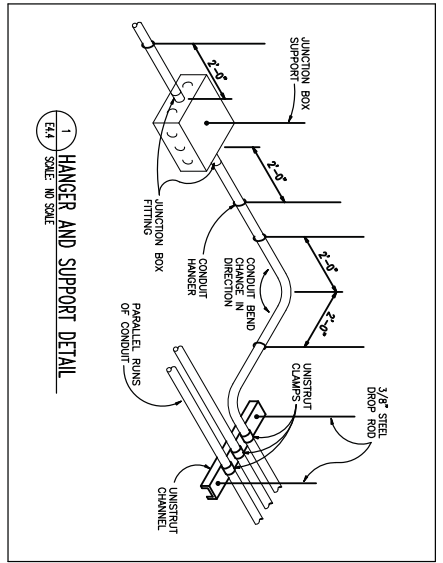

	PROJECT TITLE	STUART DEPOT COMMUNITY BUILDING
	PROJECT NO.	2012/100
	DESIGNED BY	DL
	CHECKED BY	DL
	DATE	19 AUG 2012
	APPROVED BY	DL
	DATE	19 AUG 2012
	APPROVED BY	DL

A & J Associates P.C.
 Mechanical/Electrical Engineers
 305 Beaver Creek Centre Suite B
 North Liberty, IA 52597
 (319) 624-0719 voice
 (319) 624-0841 fax
 ajspe@att.net

E4.4
 DATE: MARCH 2011
 ELEC DETAILS
 SHEET 10 OF 10E

1	ADD	42	1-5-25
REVISIONS NO. DESCRIPTION DATE 1.			

Douglas J. Steinmetz AIA
 4121 Timberline Drive NE Phone 319-294-4905
 Cedar Rapids, IA 52411 Fax 319-892-0568
 doug@djsaia.com

STUART DEPOT COMMUNITY BUILDING
PHASE 3 STP-ES-7457(604) - 81-39/ 10-STPES-115
 204 E. Front Street Stuart, IA GUTHRIE COUNTY

THIS DRAWING IS
 CONCEPTUAL ONLY.
 DO NOT USE FOR
 BIDDING, PERMITTING,
 OR CONSTRUCTION.
 DOUGLAS J. STEINMETZ, AIA